

Laser Module

LC-LMD-650-03

Ø 8 mm 650 nm Laser Module

FEATURES

1. APC (auto power control) IC inside
2. Low current consumption of the APC circuit
3. Surge current protection
4. High quality lens for output beam



PART NO. INDICATIONS

LC-LMD - 650 - 03 - XX - A

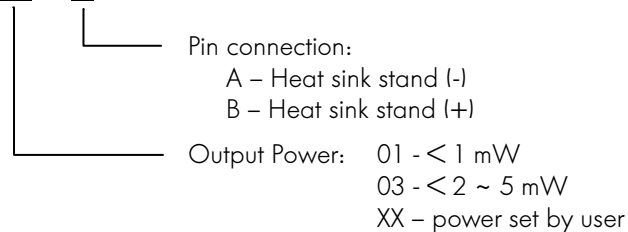

ABSOLUTE MAXIMUM RATINGS

Item	Symbol	Rating	Unit
Power supply voltage	V_{CC}	3.3	V
Laser Module optical output power	P_o	<3 mW	mW
Operation temperature	T_{opr}	0 ~ 40	C
Storage temperature	T_{stg}	0 ~ 60	C

ELECTRICAL AND OPTICAL CHARACTERISTICS ($T_c = 25\text{ C}$)

Item	Symbol	Min.	Typ.	Max	Unit	Condition	
Wavelength	λ	645	655	660	nm	$P_o = <3\text{ mW}$	
Output power	P_{out}	01	-	0.6	0.9	mW	$V_{cc} = 3\text{ V}$
		03	2.2	-	3.0	mW	$V_{cc} = 3\text{ V}$
Operation current	I_{op}	-	15	25	mA	$P_o = 3\text{ mW}$ $V_{cc} = 3\text{ V}$	
Operation voltage	V_{op}	2.5	-	3.3	Volt		
Laser Beam spot size at 10 m				<10 mm			
Divergence angle				1.1 mrad			
Mean time to failure (MTTF) 3 mW 25 C				>10000 hrs			



OUTLINE DIMENSIONS (UNITS: mm)

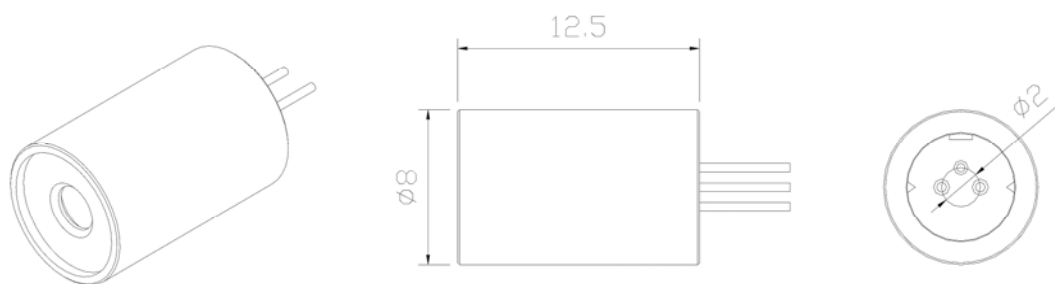

PIN ASSIGNMENT:



A type: Heat sink stand (-)

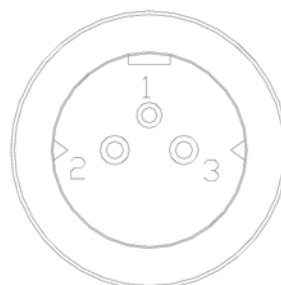

B type: Heat sink stand (+)

- Pin 1: V_{cc}
- Pin 2: GND
- Pin 3: (1) PD
for LC-LMD-650-03-XX-A/B
(2) NC (no external connection)
for LC-LMD-650-03-01/03-A/B



LASER POWER ADJUSTMENT PROCEDURE

1. Connect 1 μ F capacitor (Cx1) between Pin 1 and Pin 2.
2. Connect 20 ~ 50 K ohm variable resistor (Rx1) between Pin 2 and Pin 3.
3. Set V_{cc} to the designed value.
4. Adjust Rx1 to obtain the desired output power.
5. Laser Safety Precautions

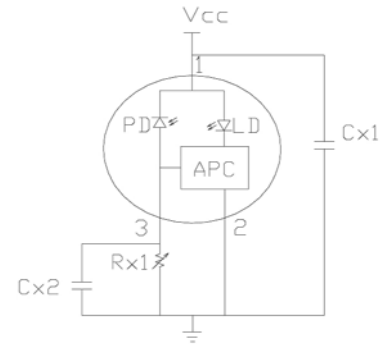

- (1) Do not increase V_{cc} value when the laser module is working near the maximum power. That is to protect laser from overdriving condition and make sure power is under 3 mW.
- (2) Do not operate the device above the maximum rating condition, even momentarily. It may cause unexpected permanent damage to the device.

LASER POWER STABILITY

- P1: 3 mW
- P2: <3.5 mW
- Pn: <3.5 mW
- ΔP : <0.5 mW
- T1: <0.1 μ s
- f2= (1/T2): 3 MHz

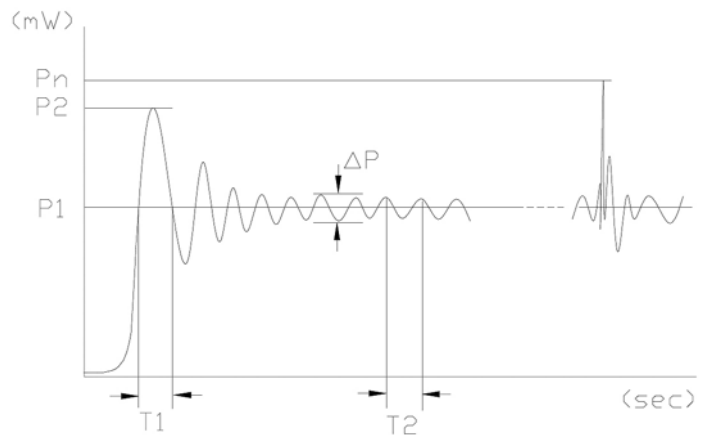

Note:

- P1: Mean power
- P2: Max power from turning on power
- Pn: Max power from V_{cc} noise
- ΔP : Power Amplitude of vibration
- T1: Time between trigger and convergence
- f2= (1/T2): Frequency of output power



INSTRUCTION MANUAL

1. DC Power connection mode 1

A type : Heat sink stand (-)

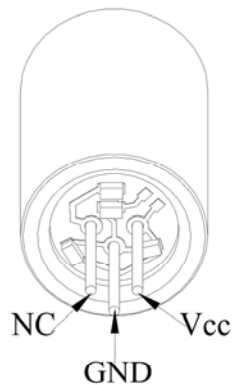

B type :Heat sink stand (+)

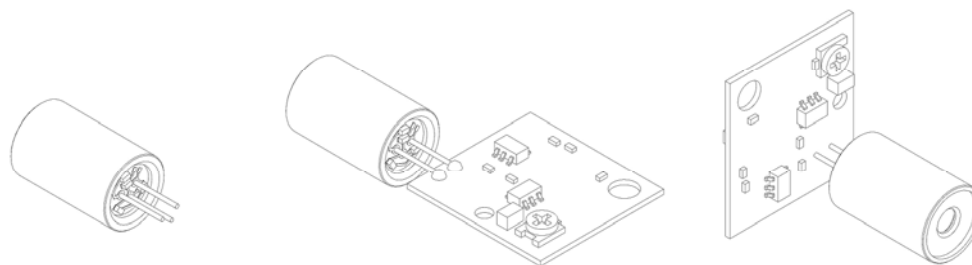

2. DC Power connection mode 2

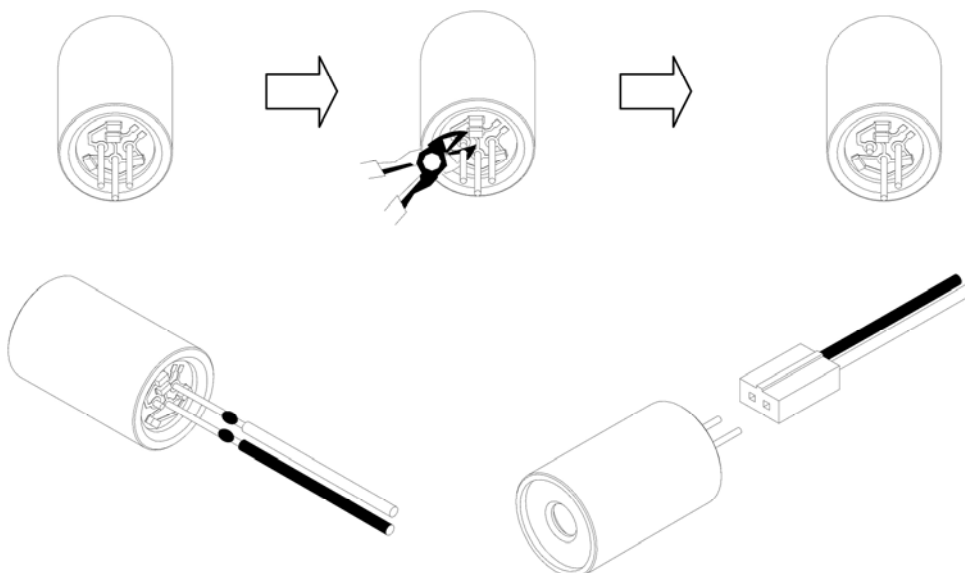

Laser Safety Precautions

1. Do not look into the laser beam directly by eyes. The laser beam may cause severe damage to human eyes.
2. Optical Lens is made of plastic or glass. Do not contaminate lens by soiling, oil or chemical.

04/07 / V2 / HW / divers-opto/module/ lc-lmd-650-03.doc

