



THE PRODUCT

Your electronics cut a fine figure from the very first moment with the SMART-BOX.

Rounded surfaces create a pleasantly smart appearance and underline the impressive qualities of the new range of cases. They also offer plenty of technical advantages.

Matching formats meet many different requirements and ensure that you always have the right case.

YOUR ADVANTAGE

Convincing design. Flush-fitting trims mask the screw attachments; instead of light grey alternatively available in other colours (without UL 94 V-0) on request, e.g. to colour-code the function or to match the case with your corporate image.

High-quality material ABS (UL 94 V-0) for use in tough conditions. Also flame-retardant and self-extinguishing.

Robust and sealed up to IP 66.

The cover retention device already included in the supply facilitates all installation and service work.

Optional lock as protection against unauthorised opening available as an accessory.

Recessed operating area for the protection of the membrane keyboard. Additional surface for labels on the underside.



Light grey, RAL 7035

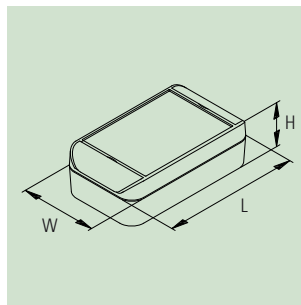

APPLICATIONS

Ideal for design-oriented electrical and electronic applications, e.g. in heating, air conditioning and ventilation engineering, in control and system engineering, in safety technology etc.

PROTECTION CLASS UP TO IP 66

With sealing, already prefitted in the top.

MAX. SIZE OF PCB

SMART-BOX	L x W in mm	
	base part	top part
120 x 90	81 x 81	78 x 79
160 x 90	121 x 81	118 x 79
160 x 130	121 x 121	118 x 119
200 x 110	161 x 101	158 x 99
280 x 170	241 x 161	238 x 159

INFO-BOX

High-quality stainless steel screws

The case screws used have no less than 3 special features.

- The trapezoidal thread allows a high degree of positive locking. Pre-formed threads in the bottom parts of the cases make it possible to loosen the threaded connection a thousand times without impairing the function.
- High resistance to corrosion – even against aggressive media – through A2 steel alloy.
- The head of the screw is suitable for crosstip screwdrivers and slotted screwdrivers.

Excellent material properties

The standard material used is flame-resistant and originally coloured ABS with the classification V-0 in accordance with UL 94. This is tested on sample items, and does not burn for longer than 10 seconds in the standardised experimental arrangement. In the event of a fire this can mean the “survival” of the case and its functions!
See also material properties pages 111 - 113.

ENCLOSURES*1

SMART-BOX	Outside dim. in mm			Equipment (dim. in mm) protection class up to	Material	Part-No.
	L	W	H			
width 90	120	90	50	IP 66	ABS (UL 94 V-0)	C 60 09 121
	160	90	50	IP 66	ABS (UL 94 V-0)	C 60 09 161
width 130	160	130	60	IP 66	ABS (UL 94 V-0)	C 60 13 161
width 110	200	110	60	IP 66	ABS (UL 94 V-0)	C 60 11 201
width 170	280	170	60	IP 65	ABS (UL 94 V-0)	C 60 17 281

ACCESSORIES

Article	For enclosure SMART-BOX	Version / Application	Part-No.
① Case feet	for all case sizes	when using the case for desktop application, 4 pcs	C 22 99 018
② Lock	for all case sizes	safety lock to prevent unauthorised access, 1 pc	C 61 00 005
③ Security kit	for all case sizes	for use with lead tags, 2 pcs	C 61 00 016
		plug as a single part, 1 plug	C 61 00 006



*1 Supply: Each 1 base and top part with sealing, 2 trims (hinged), 1 assembly kit incl. cover retention device.

NEW PRODUCT