

PANdrive PDo13-42 and TMCM-013 and TMCM-013-LA Manual

**STEPPER motor controller/driver module
1A RMS (1.5A peak) / 30V
with RS485 and step-/ direction interface**

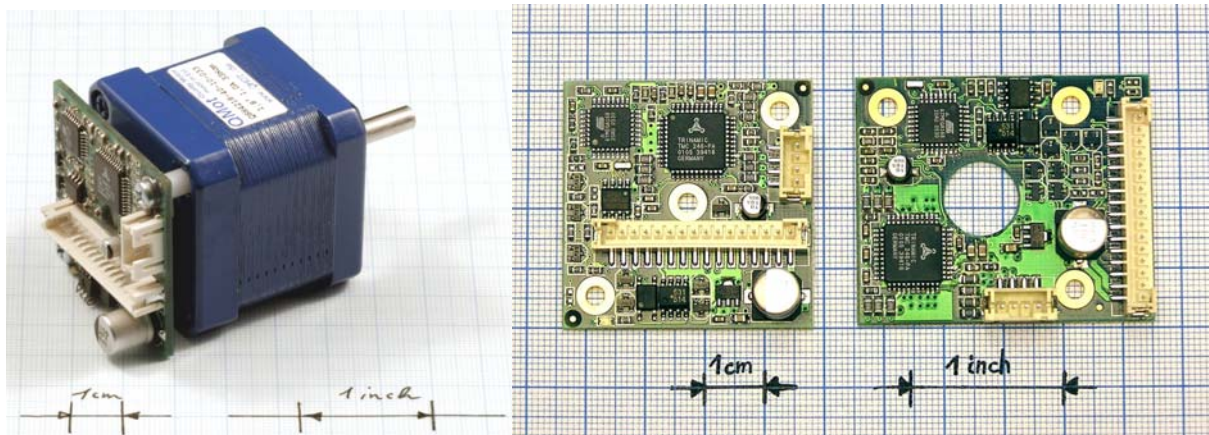

Trinamic Motion Control GmbH & Co. KG
Sternstraße 67
D - 20357 Hamburg, Germany
<http://www.trinamic.com>

Table of Contents

1	Features.....	4
2	Life support policy.....	5
3	Outer Description	6
3.1	Pinning.....	6
3.2	Dimensions.....	7
3.3	Connectors.....	7
4	Operational Ratings.....	8
4.1	Step, Direction and Disable Inputs	9
5	Getting Started.....	10
5.1	Assembly of Parts.....	10
5.2	Motor	10
5.2.1	Motor Choice.....	10
5.2.1.1	Motor velocity	11
5.2.1.2	Chopper Modes 0 (SPI / Default Mode) and 1 (PWM).....	11
5.2.1.3	Chopper Mode 2 (PHASE).....	11
5.2.2	Connecting Motor and Power Supply.....	12
5.3	Power Supply Requirements	12
5.4	Connections for Step/Direction-Mode	13
5.5	Connections for RS485 Interface.....	13
5.5.1	Interface installation	14
5.5.2	Control with terminal program.....	14
6	Functional Description.....	15
6.1	Disable	15
6.2	RS485 Control Interface	15
6.2.1	RS485 Commands.....	16
6.2.1.1	Example for test move:.....	17
6.2.1.2	Motor Current (C)	17
6.2.1.3	Failure Readout (E)	17
6.2.1.4	StallGuard (G).....	18
6.2.1.5	Limit Switch (L).....	18
6.2.1.6	Alert settings (N).....	18
6.2.1.7	Output setting (O).....	19
6.2.1.8	Set Position (P), Read Current Position (R).....	19
6.2.1.9	I/Os Readout (Q).....	19
6.2.1.10	Baud Rate (U)	19
6.2.1.11	Velocity Mode (V).....	19
6.2.1.12	Store Parameters to EEPROM (W).....	20
6.2.1.13	Microstep Resolution (Z)	20
6.2.2	Chopper Modes.....	21
6.2.2.1	Chopper Mode 0 (SPI) / Default Mode.....	21
6.2.2.2	Chopper Mode 1 (PWM)	21
6.2.2.3	Chopper Mode 2 (PHASE).....	21
6.2.2.4	Chopper mode 3 (Phase and SPI).....	22
6.2.2.5	Chopper mode 4 (PWM and SPI)	22
6.3	Step / Direction	22
6.3.1	Direction.....	23
6.3.2	Step	23
6.4	Firmware Update.....	24
6.5	Reset to factory default.....	25
6.6	Option: Pseudo DC-Motor mode (not supported by software yet).....	25
6.6.1	Changes required for DC motor mode operation	25
6.6.2	Parameterizing with RS485.....	26
6.6.3	Motion Control.....	26
7	Revision History.....	27
7.1	Documentation Revision.....	27
7.2	Firmware Revision.....	27

List of Figures

Figure 3.1: Pinning of TMC-013 and TMC-013-LA	6
Figure 3.2: Dimensions for TMC-013.....	7
Figure 3.3: Dimensions for TMC-013LA.....	7
Figure 4.1: Step, Direction and Disable Inputs	9
Figure 5.1: Assembly of parts.....	10
Figure 5.2: Maximum Supply Voltage regarding Motor Current and Inductivity	12
Figure 5.3: Connecting Motor and Power Supply	12
Figure 5.4: Contacts for Step-Direction.....	13
Figure 5.5: Contacts for RS485 with an adapter	14
Figure 5.6: Connection settings for RS485	14
Figure 6.1: Main parts of PD-013-42.....	15
Figure 6.2: Alarm and GPO.....	19
Figure 6.3: Step-Direction signals and motor reactions.....	23
Figure 6.4: Step and Direction Signal	24
Figure 6.5: Firmware update tool	24
Figure 6.6: Reset to factory default	25
Figure 6.7: GPI wiring scheme.....	25
Figure 6.8: External Changes for act like DC-Motor option.....	26

List of Tables

Table 1.1: Order codes.....	4
Table 3.1: Pinning of TMC-013 and TMC-013-LA.....	6
Table 4.1: Operational Ratings	8
Table 5.1: Maximum Supply Voltage regarding Motor Current and Inductivity.....	11
Table 6.1: RS485 Commands.....	16
Table 6.2: Motor Current Examples	17
Table 6.3: Failure readout in SPI mode.....	17
Table 6.4: StallGuard	18
Table 6.5: Limit switch	18
Table 6.6: Alert adjustments.....	18
Table 6.7: Output adjustment.....	19
Table 6.8: I/Os Readout.....	19
Table 6.9: Baud rate	19
Table 6.10: Adjustment of Microstep Resolution.....	20
Table 6.11: Chopper mode 3 switching velocities	22
Table 6.12: External signals and motor reactions	22
Table 7.1: Documentation Revisions	27
Table 7.2: Firmware Revisions.....	27

1 Features

The PD-013-42 is a mechatronic stepper motor module with step-/direction interface plus remote configuration access. It is based on the TMCM-013-42 one axis stepper motor controller and driver for integration directly on a NEMA-17 motor. With up to 1.5 A coil current it operates from a single 7 to 30V power supply. It provides step/direction, RS-485 and an optional pseudo DC interface for remote control. Up to 256 micro steps are available for either high accuracy or high speed. It integrates velocity and torque control as well as positioning mode. An update of the firmware is possible via the serial interface. The system features sensorless stall detection (StallGuard™). The TMCM-013-LA supports NEMA-17 linear actuators.

Applications

- Mechatronic step-/ direction stepper driver for general decentralized applications
- Robotics
- Remote diagnostics / feedback allows for high-reliability drives

Motor type

- Coil current from 300mA to 1A RMS (1.5A peak)
- 7V to 30V nominal supply voltage

PANdrive Motor data

- all PANdrive motors optimized for 1A RMS coil current
- 200 fullsteps per revolution
- please refer to motor data sheet for detailed motor information

Highlights

- Remote controlled diagnostics and parameterization (RS485)
- Reference move and turn CW / CCW via RS485
- Stand-alone operation, adjusted via RS485
- Fully protected drive
- Digital selection of motor current and standby current
- Local reference move using sensorless StallGuard feature or reference switch
- All setup parameters are stored in internal EEPROM, no bus system required in end application
- Micro step resolution can be changed to get high accuracy or high speed with the possibility to combine both
- Different chopper modes allow best adaptation to application / motor
- Many adjustment possibilities make this module the solution for a great field of demands

Other

- pluggable JST connectors
- RoHS compliant latest from 1 July 2006

Order code	Description	Dimensions [mm³]
PD1-013-42	PANdrive 0.27Nm	53 x 42 x 42
PD2-013-42	PANdrive 0.35Nm	59 x 42 x 42
PD3-013-42	PANdrive 0.49Nm	69 x 42 x 42
TMCM-013	Electronics module	14 x 42 x 42
TMCM-013-LA	Electronics module	14 x 42 x 50

Table 1.1: Order codes

2 Life support policy

TRINAMIC Motion Control GmbH & Co. KG does not authorize or warrant any of its products for use in life support systems, without the specific written consent of TRINAMIC Motion Control GmbH & Co. KG.

Life support systems are equipment intended to support or sustain life, and whose failure to perform, when properly used in accordance with instructions provided, can be reasonably expected to result in personal injury or death.

© TRINAMIC Motion Control GmbH & Co. KG 2007

Information given in this data sheet is believed to be accurate and reliable. However no responsibility is assumed for the consequences of its use nor for any infringement of patents or other rights of third parties, which may result from its use.

Specifications subject to change without notice.

3 Outer Description

3.1 Pinning

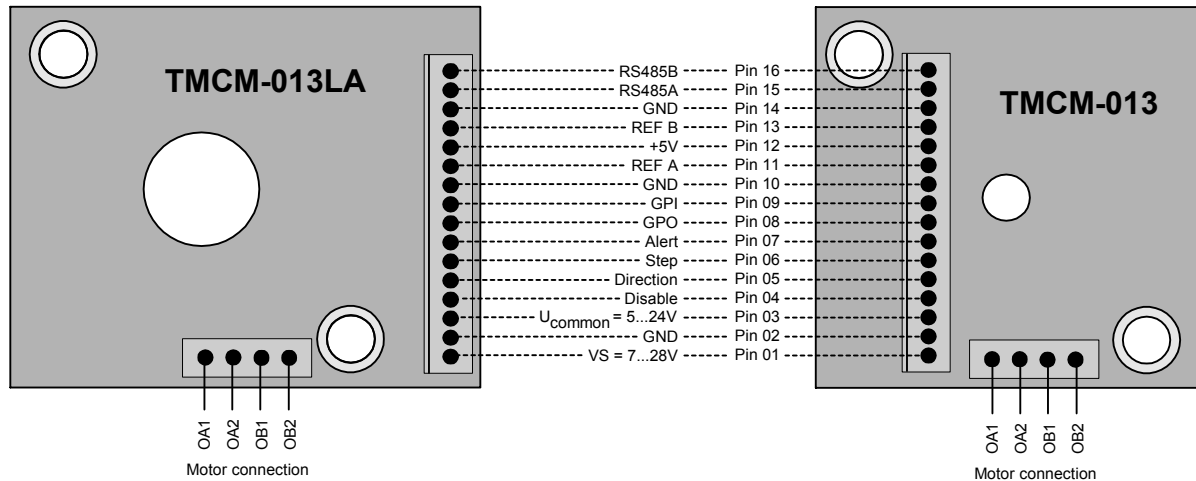

Figure 3.1: Pinning of TMCM-013 and TMCM-013-LA

Pin	Number	Function
VS	1	Positive power supply voltage
GND	2	GND, power
V _{COM}	3	Reference voltage for step-direction inputs. Positive optocoupler supply. Required for negative logic.
Disable	4	Tie to GND to shut down motor power, leave open or at V _{COM} otherwise
Direction	5	Tie to GND to inverse motor direction, leave open or at V _{COM} otherwise
Step	6	Step signal, optically isolated (Cathode of optocoupler)
Alert	7	Alert output, for wiring scheme see Figure 6.2
GPO	8	General Purpose Output, for wiring scheme see Figure 6.2
GPI	9	General Purpose Input, for wiring scheme see Figure 6.7
GND	10	GND reference
REF A	11	Reference Signal A
+5V	12	Constant +5V output, reference
REF B	13	Reference Signal B
GND	14	GND for RS485
RS485 +	15	RS485 remote control access +, TTL input
RS485 -	16	RS485 remote control access -, TTL input
OA1, OA2		Connections for motor coil A
OB1, OB2		Connections for motor coil B

Table 3.1: Pinning of TMCM-013 and TMCM-013-LA

3.2 Dimensions

42mm*42mm*14mm (Height is measured by the highest part on PCB, be aware that the connectors are upright). The mounting holes and the center hole for TMCM-013 are 3.2mm. The center hole of the TMCM-013-42 is 6.0mm and of the TMCM-013LA 12.5mm.

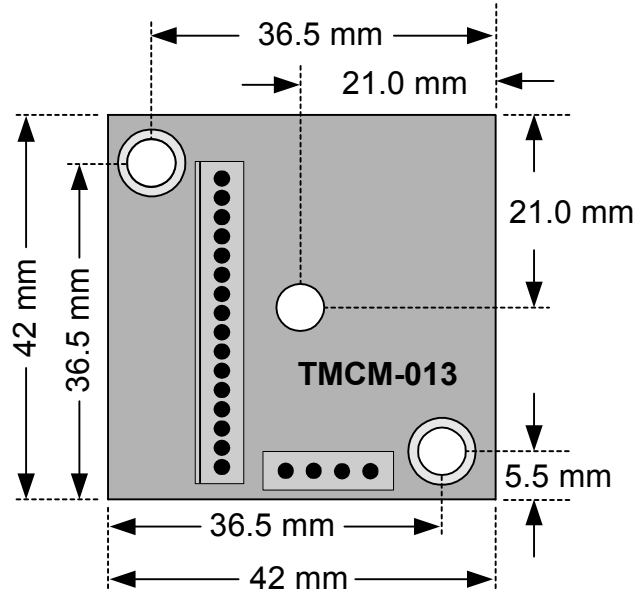

Figure 3.2: Dimensions for TMCM-013

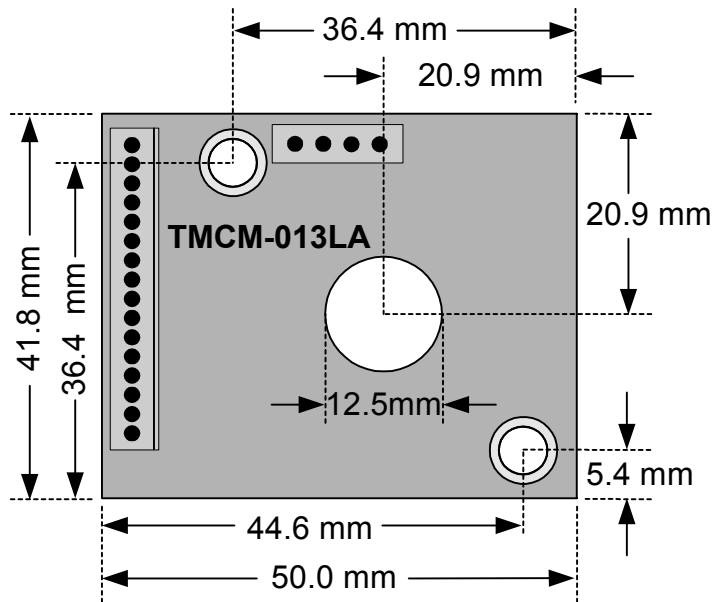

Figure 3.3: Dimensions for TMCM-013LA

3.3 Connectors

Both connectors are crimp connectors series B4B-PH-SM3-TB, PH-connector.

Motor: 4 pin connector

Control: 16 pin connector

4 Operational Ratings

The operational ratings show the intended / the characteristic range for the values and should be used as design values. In no case shall the maximum values be exceeded.

Symbol	Parameter	Min	Typ	Max	Unit
V_S	Power supply voltage for operation	7	12 .. 24	30	V
I_{COIL}	Motor coil current for sine wave peak (chopper regulated, adjustable via software)		440..1500		mA
I_{MC}	Effective motor current (RMS)		300 .. 1000	1000	mA
f_{CHOP}	Motor chopper frequency (actual frequency depends on operation mode)		20 / 36		kHz
I_S	Power supply current		$\ll I_{COIL}$	$1.4 * I_{COIL}$	A
V_{ISO}	Isolation voltage of optocoupler		± 42	± 100	V
V_{COM}	Supply voltage for step, direction and disable; (inputs have negative logic)		5 .. 24	27	V
V_{OPTON}	Signal active voltage at disable, step and direction input (optocoupler on, measured from U_{COM} to input)	3.5	4.5 .. 24	30	V
V_{OPTOFF}	Signal inactive voltage at disable, step and direction input (optocoupler off, measured from U_{COM} to input)	-5.5	0	2	V
I_{OPT}	Optocoupler current (internally regulated)		4	8	mA
f_{STEP}	Step frequency			350	kHz
t_{STEPLO}	Step impulse low time (opto coupler on)	0.7			μs
t_{STEPHI}	Step impulse high time (opto coupler off)	2.0			μs
$t_{DIRSETUP}$	Direction setup time to rising edge of step input	0			μs
$t_{DIRHOLD}$	Direction hold time after rising edge of step input	3.0			μs
V_{GPI}	Input voltage on GPI	-2	0 ... 5	30	V
V_{GPO}	Output voltage on GPO and Alert (open collector)	-1		100	V
I_{GPO}	Output current on GPO and Alert (open collector)			-150	mA
T_{ENV}	Environment temperature for operation	-25		70	$^{\circ}C$

Table 4.1: Operational Ratings

4.1 Step, Direction and Disable Inputs

The inputs disable, dir and step are electrically isolated from the module. The inputs are related to V_{COM} . In a typical application, U_{COM} shall be tied to the positive supply voltage of the master and the inputs are driven by open collector or push / pull outputs. V_{OPTOFF} and V_{OPTON} must not exceed V_{COM} to avoid reverse polarity for the opto couplers.

OFF: $V_{COM} - V_{IN} < 1.0V$

ON: $V_{COM} - V_{IN} \geq 3.5V$

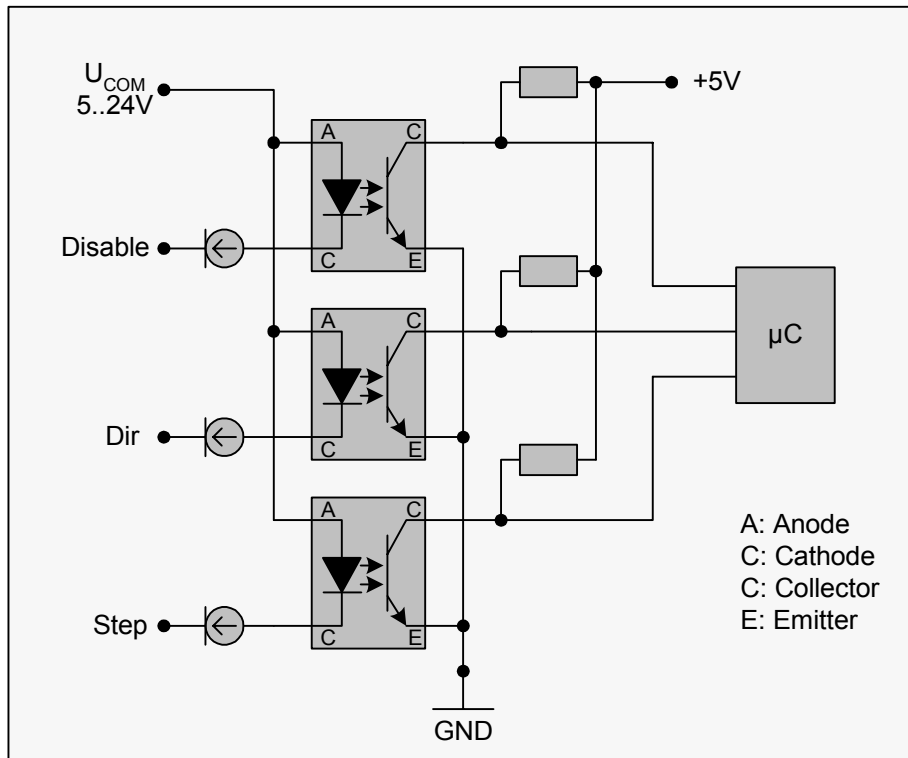
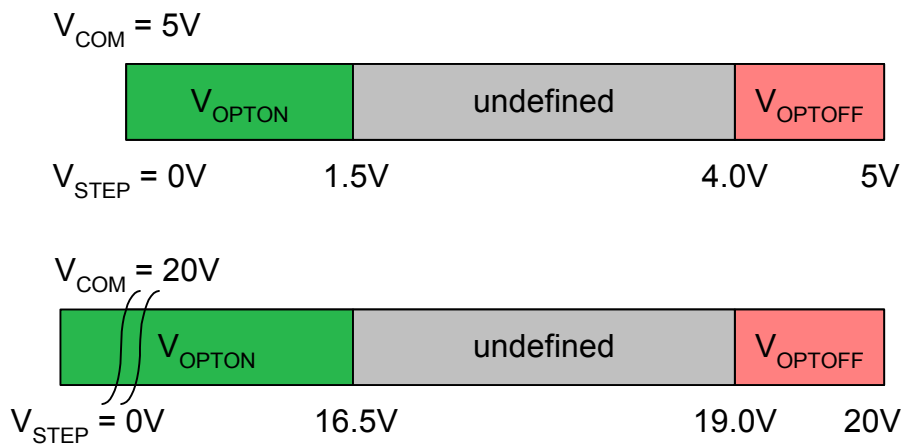

Figure 4.1: Step, Direction and Disable Inputs

Examples:



5 Getting Started

5.1 Assembly of Parts

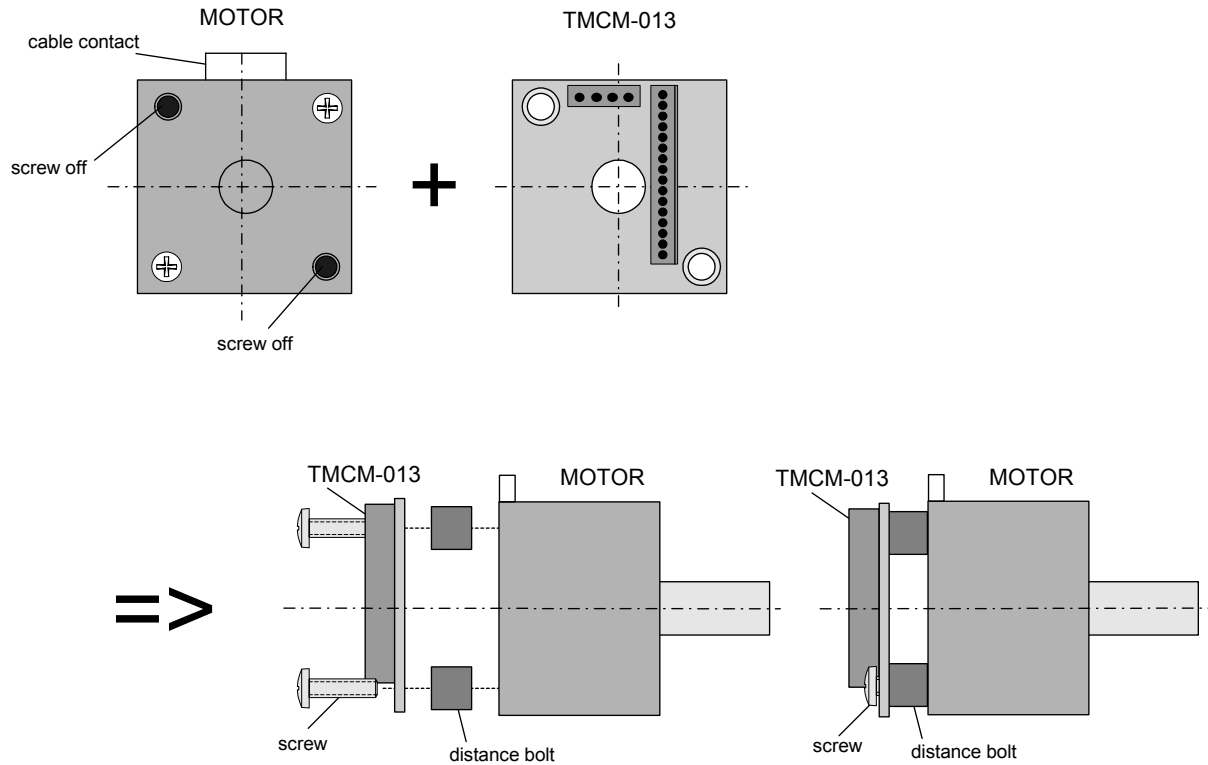

Figure 5.1: Assembly of parts

We recommend a minimum distance between the TMCM-013 and motor of 5mm. The module can be directly attached to the motor backbell with an electrical insulation spacer. Appropriate cooling might be necessary if the motor itself gets very hot.

5.2 Motor

Attention: Do not connect or disconnect the motor while power on. Damage to the module may occur.

Attention: A too high motor current setting can damage you motor! If in doubt, start with a low current setting and check motor temperature. If the motor heats up very quickly, check all settings. The motor shall never reach a temperature above 100°C under any circumstances. Some stepper motors need contact to metallic parts to allow continuous operation. Mind the default settings, when you operate in step / direction mode the first time! You can store your own settings in the module permanently.

5.2.1 Motor Choice

Care has to be taken concerning the selection of motor and supply voltage. In the different chopper modes different criteria apply. Modes 0 and 1 are quite insensitive to the motor choice, while Mode 2 is very sensitive, because it uses a different motor current regulation scheme. This chapter gives some mathematical information on the motor choice, but you can skip it if you want to experiment with a

given motor. Normally, best results will be achieved when operating the given motor in a range of 50 to 100% of nominal motor current (see motor data sheet). Mode 2 and mode 1 are mainly intended for slow, smooth and very exact movements, due to the high microstepping resolution. For most dynamic operation choose mode 0, or the combined modes 3 and 4 which use mode 1 or 2 for slow movements and switch to mode 0 at a defined velocity.

5.2.1.1 Motor velocity

Whenever it is desired to maximize the motor velocity in a given application, it is important to understand limitations due to supply voltage and motor inductivity. Please consult your motor data sheet for this, as well as the choice of the chopper mode. Chopper mode 0 allows maximum motor velocity.

5.2.1.2 Chopper Modes 0 (SPI / Default Mode) and 1 (PWM)

In these two modes the maximum supply voltage (V_S) of the motor must not exceed 22-25 times the nominal motor voltage (V_N), regarding the multiplication of $I_{COIL, MAX}$ and R_{MOTOR} . A higher value would lead to an excess of motor rating.

The minimum supply voltage has to be above two times the nominal motor voltage.

$$2 \cdot V_N \leq V_S \leq 22 \dots 25 \cdot V_N$$

$$V_N = I_{COIL, MAX} \cdot R_{MOTOR}$$

5.2.1.3 Chopper Mode 2 (PHASE)

In Table 5.1 and Figure 5.2 examples of maximum supply voltages V_S regarding the current I_{COIL} and inductivity L of your motor are specified.

For further information, including a formula and description how to calculate the maximum voltage for your setup, refer to 6.2.2.3.

I_{COIL} (RMS)	L (min.)	V_S (max.)
1000 mA	1.2 mH	24 V
	0.9 mH	18 V
	0.6 mH	12 V
	0.35 mH	7 V
700 mA	1.7 mH	24 V
	1.3 mH	18 V
	0.9 mH	12 V
	0.5 mH	7 V
500 mA	2.4 mH	24 V
	1.8 mH	18 V
	1.2 mH	12 V
	0.7 mH	7 V
350 mA	3.4 mH	24 V
	2.6 mH	18 V
	1.7 mH	12 V
	1.0 mH	7 V

Table 5.1: Maximum Supply Voltage regarding Motor Current and Inductivity

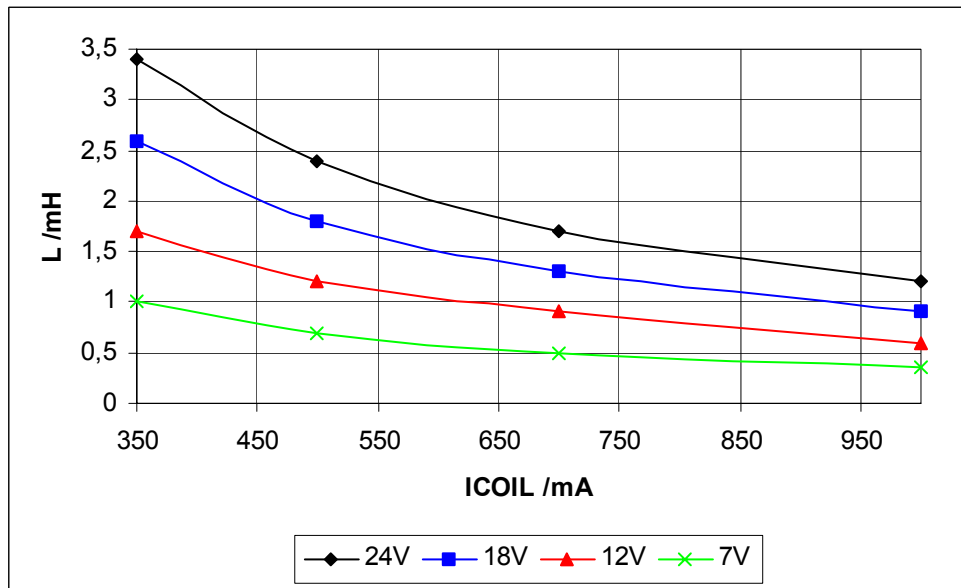

Figure 5.2: Maximum Supply Voltage regarding Motor Current and Inductivity

Any combination of motor coil current and inductivity which is above the curve for maximum supply voltage (V_s) is possible to drive the motor in this mode. Check your motor datasheet please. If in doubt, please start with a lower supply voltage and check motor heating when raising the voltage.

5.2.2 Connecting Motor and Power Supply

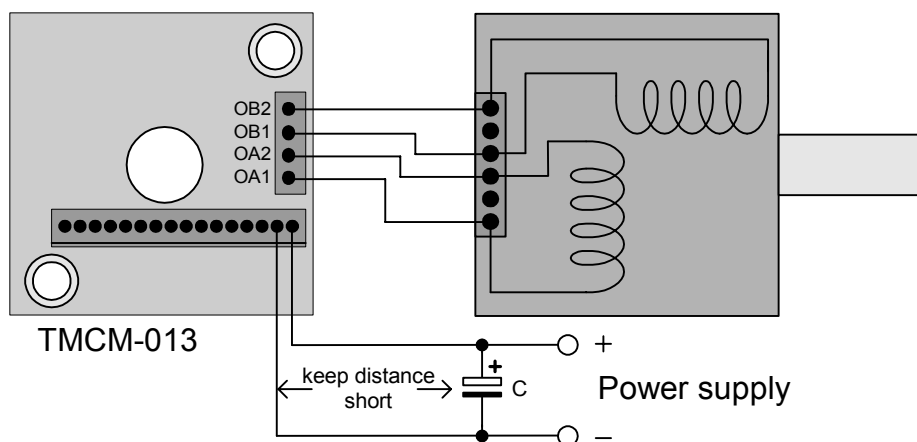

Figure 5.3: Connecting Motor and Power Supply

5.3 Power Supply Requirements

The power supply voltage shall be in the limits as given in the chapter 4 under operational ratings. Please note that there is no protection against reverse polarity or too high voltage. The power supply typically should be within a range which fits the motor requirements, as described in chapter 5.2.1. When using supply voltages near the upper limit, a regulated power supply becomes a must. Please ensure, that enough power filtering capacitors are provided in the system (1000µF or more recommended), in order to absorb mechanical energy fed back by the motor in stalling conditions. In larger systems a zener diode circuitry might be required, when motors are operated at high velocities.

The power supply should be designed in a way, that it supplies the nominal motor voltage at the desired maximum motor power. In no case shall the supply value exceed the upper / lower voltage limit. To ensure reliable operation of the unit, the power supply has to have a sufficient output capacitor and the supply cables should have a low resistance, so that the chopper operation does not lead to an increased power supply ripple directly at the unit. Power supply ripple due to the chopper operation should be kept at a maximum of a few 100mV.

Therefore we recommend to

- a) keep power supply cables as short as possible
- b) use large diameter for power supply cables
- c) if the distance to the power supply is large (i.e. more than 2-3m), use a robust 1000µF or similar additional filtering capacitor located near to the motor driver unit. Choose the capacitor voltage rating fitting to the maximum operating voltage.

The overall power rating mainly depends on the motor used and on the mechanical output power, i.e. the motor velocity and desired torque. As a thumb rule, a 42mm class motor will require a 10W (short motor) to 20W (long motor) power supply, when operated at maximum rated current and low velocities. Operation at very high velocities will increase the power demand up to the double value.

5.4 Connections for Step/Direction-Mode

The step-direction-mode is enabled if the acceleration is set to 0 (default) using the RS485.

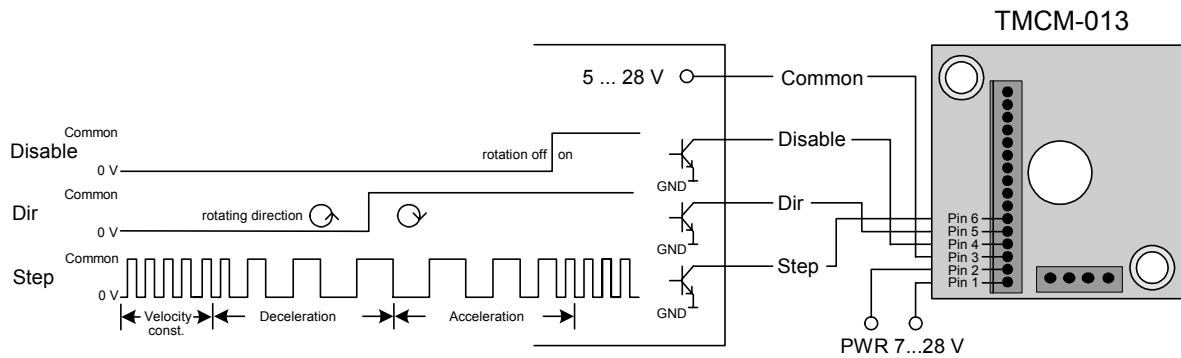

Figure 5.4: Contacts for Step-Direction

The maximum step frequency is 350 kHz (limited by the opto couplers).

5.5 Connections for RS485 Interface

The RS485-mode allows for configuration of motor parameters as well as remote control of the motor.

5.5.1 Interface installation

To connect the module to a PC a RS485 interface is required, for example Trinamic's new USB-2-485 or any other RS485 adapter, like the standard RS232 to RS485-converters. Input A has to be connected to pin 15 of the TMCM-013 and Input B to pin 16.

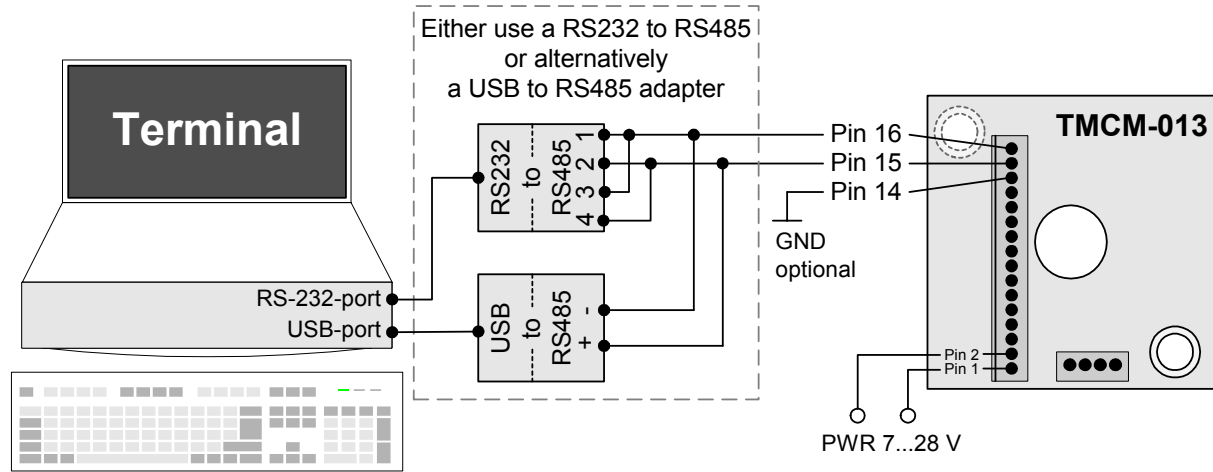

Figure 5.5: Contacts for RS485 with an adapter

5.5.2 Control with terminal program

Having installed the hardware, the TMCM-013 can be controlled with any terminal program, like HyperTerminal that comes with MS-Windows. Following steps are described for HyperTerminal but are similar for the other terminal programs:

1. Start HyperTerminal
2. A window for a new connection opens. Fill in a name and select icon. Press OK.
3. Select the appropriate COM-port and press OK.
4. Fill in the values like in Figure 5.6 and confirm with OK.

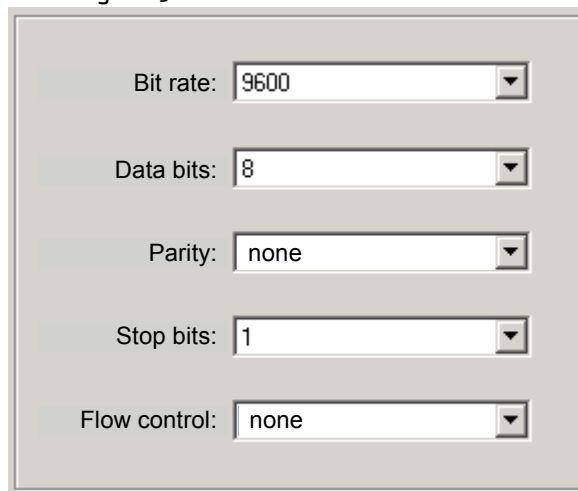

Figure 5.6: Connection settings for RS485

Type into the terminal window commands like "AV 50000", "AA 300" or "Ac" and execute each with ENTER. With standard RS485 adapters the typed value may be echoed and lines like AAVV 5500000000 for the typed AV 50000 appear. The value sent to the module is the typed one and not the displayed. Try to change ASCII settings in HyperTerminal.

An acceleration differing from zero is required to get velocities in RS485 mode. Setting or storing this value to the EEPROM disables step/direction control until acceleration is set to zero again (and eventually stored) or the board is reset to factory default.

6 Functional Description

The TCM-013 module has three different modes to control a stepper motor: step-direction, RS485 and eventually pseudo DC-mode. With the RS485 it is possible to change parameters and save them to the EEPROM of the module to have all options in any mode. Therefore there are different settings like microstep resolution possible in step-direction mode also.

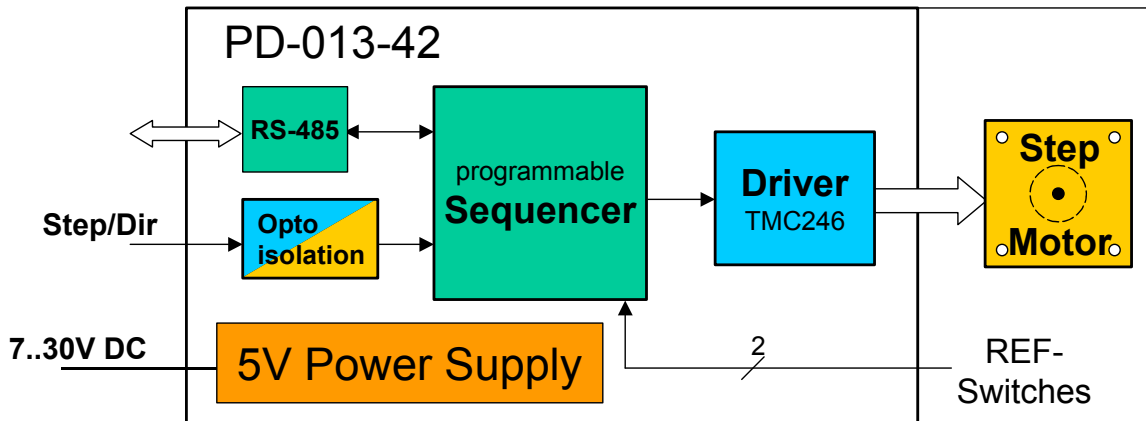

Figure 6.1: Main parts of PD-013-42

6.1 Disable

Description: The disable works as an emergency shutdown. Connected to ground all power to the motor will shut down independent of the current settings.

It is in the users responsibility to stop the step impulses or set the velocity to zero before enabling the motor again, because it would start abrupt otherwise.

Function Table:

V_{OPTON}	open wire	V_{OPTOFF}
motor disabled	motor enabled	

6.2 RS485 Control Interface

The RS485 interface can control all functions of the TCM-013. It is possible to change parameters, with this interface which are also valid in the other modes like max. velocity or acceleration. The parameters can be written to the EEPROM to obtain the changes after a restart.

A Reset to factory default is possible. Default address byte is "A" and default baud rate is 9600 baud. This mode can only be used with an appropriate RS485 interface. Commands are sent with a terminal program, refer 5.5.

6.2.1 RS485 Commands

For RS485 commands write the address byte (default is A) first, followed by a command from the following list. A small command letter provides the actual setting. All values are ASCII.

Command	Function	Description	Range	Factory Default
A, a	Acceleration	Acceleration: $v = 28.96 * a$	0..2500000	0
C, c	Set Motor Current	Motor current in percentage of maximum current (0..100% * 1500mA). Refer to 6.2.1.2	0..100	50
E	Failure Readout	Provides Failure readout. Refer 6.2.1.3	8 Bit (SPI) 1Bit (others)	
G, g	StallGuard	In mode o (SPI) the StallGuard feature is functional. 'g' provides the actual StallGuard load value, not the setting. Refer 6.2.1.4	-7..0..+7	0
L, l	Limit switch	Used to switch on and off reference run values. Refer 6.2.1.5	byte	
M, m	Select Mode	Select chopper mode: 0:SPI, 1:PWM, 2:PHASE, 3 & 4: Combinations, Refer 6.2.2	0, 1, 2, 3, 4	0
N, n	Alert	Alert output adjustments, Refer 6.2.1.6	2 bit	0
O, o	Set Output	Output adjustments, Refer 6.2.1.7	2 bit	0
P	Set Position	Set position without moving the motor. See command 'R' to read out current value.	32 bit	0
Q	Read I/Os	Provides out of the I/O the values of the ports GPI, REF_A, REF_B, GPO and ALARM. Refer to 6.2.1.8		
R	Read Current Position	Provides the current position of the motor. See command 'P' to manipulate this value.	32 bit	
S	Changes address byte	Capital letter followed by the command 'S' makes this letter the new address byte		A
T, t	RS485-Timeout	Sets the RS485-Timeout		
U, u	Set baud rate	Sets baud rate for RS485 communication. Refer to 6.2.1.10	0..7	0
V, v	Velocity for Rotation	Velocity for rotation / reference run $v = n * 0.149157 \text{ usteps/s}$ Additional Parameter o or missing: Carriage Return (CR) comes after acceleration phase Additional Parameter is 1: no delay of CR	+/- 2500000 0 or 1	0
W	Store parameters to EEPROM	Stores settings to EEPROM to restart with the same performance. Refer 6.2.1.12		
X	Version number	Provides version number of implemented Software		
Y, y	Standby current	Sets 0..100% of maximum current after 1 second motor inactivity. For no standby current use the same value as for "Set motor current".	0..100	20
Z, z	Microstep Resolution	Sets the maximum microstep resolution (0: max; 6: min). Refer to 6.2.1.13, Table 6.10	0..6	0

Table 6.1: RS485 Commands

Examples:

1. Set chopper mode to SPI Mode:AM 0 ⇒ ENTER
2. Read out the actual mode Am ⇒ ENTER
3. Change Microstep resolution ¼ of max. resolution: AZ 2 ⇒ ENTER

6.2.1.1 Example for test move:

- **Different accelerations and velocities**
AA 500, AV 50000, AV -50000 ⇒ try other AA 0...8000, AV 0...400000
- **Max. current – test of torque**
AA 500, AV 50000, AC 200 ⇒ test torque manually ⇒ AC 20 ⇒ test torque
- **Read and set position**
AV 0, AR, AA 500, AV 50000, AR, AP 0, AR

6.2.1.2 Motor Current (C)

The motor current can be set by the user. To do this use the RS485 command "AC" in addition with a percent value. To calculate the actual setting, please use the 100% values as shown in the table. Internally the current is regulated by two independent parameters for the best module/motor performance possible.

For chopper mode 2, the maximum setting is about 75% to 90% - at higher settings, motor microstep behavior may become harsh. The actual maximum depends upon the actual motor. This is to avoid the motor coil current raising above the 100% setting at any time. Not all currents can be continuously driven at all supply voltages / cooling circumstances. Please refer to motor current limitations.

AC	I _{COIL.PP}	I _{COIL.RMS}	% to max. I _{COIL}
100	1.50A	1.06A	100% *)
80	1.20A	0.85A	75%
66	1.00A	0.71A	66%
50	0.75A	0.53A	50%
33	0.50A	0.35A	33%
20	0.30A	0.21A	25%
0	0A	0.00A	0%

Table 6.2: Motor Current Examples

*) Not possible for chopper mode 2.

6.2.1.3 Failure Readout (E)

The TMC-013 provides a full driver failure analyses in SPI mode (8 Bit). The returned bit assignments are as follows:

Bit	Name	Function	Remark
7	OT	overtemperature	"1" = driver chip off due to overtemperature
6	OTPW	temperature prewarning	"1" = driver chip prewarning temperature exceeded
5	UV	driver undervoltage	"1" = undervoltage on VS
4	OCHS	overcurrent high side	3 PWM cycles with overcurrent within 63 PWM cycles
3	OLB	open load bridge B	Open load detection can occur at fast motion also.
2	OLA	open load bridge A	Open load detection can occur at fast motion also.
1	OCB	overcurrent bridge B low side	Short circuit detected. Please check motor wiring.
0	OCA	overcurrent bridge A low side	Short circuit detected. Please check motor wiring.

Table 6.3: Failure readout in SPI mode

In the other two modes the failure analysis consists of only one bit:

1: short circuit or overtemperature

0: no failure

6.2.1.4 StallGuard (G)

The StallGuard feature is available in the default mode 0 (SPI) only. It is a sensorless load measurement and stall-detection. Overload is indicated before steps are lost. The command letter 'g' (small) does not provide the setting (-7 ... 7) but the actual StallGuard value (motor load), so easy calibration is possible. To use StallGuard in an actual application, some manual tests should be done first, because the StallGuard level depends upon the motor velocities and on the occurrence of resonances. When switching on StallGuard, the motor operation mode is changed and microstep resolution may be worse. Thus, StallGuard should be switched off when not in use.

Value	Description
-7..-1	Motor stops when StallGuard value is reached and position is set zero (useful for reference run).
0	StallGuard function is deactivated (default)
1..7	Motor stops when StallGuard value is reached and position is not set zero.

Table 6.4: StallGuard

6.2.1.5 Limit Switch (L)

The parameter 'L' defines the different reference entrances of the module. The motor stops when the defined position is reached.

Bit	Motor stops at
0	REF_B = 0
1	REF_A = 0
2	GPI = 0
3	REF_B = 1
4	REF_A = 1
5	GPI = 1
6	0: soft stop, 1: hard stop
7	0: sets position zero 1: sets position not to zero

Table 6.5: Limit switch

To activate a reference switch set the appropriate bit to 1 (decimal entry). When motor stops the position counter is set to zero.

Example:

AL 8 ⇒ ENTER : Activates REF_B = 1. When destination reached motor stops and position counter is set to zero.

6.2.1.6 Alert settings (N)

The bit settings are as follows:

Bit	Value	Description
0	0	ALARM output is inactive
	1	ALARM output is active
1	0	No function
	1	ALARM is set to active when driver detects a failure

Table 6.6: Alert adjustments

6.2.1.7 Output setting (O)

The bit settings are as follows:

Bit	Value	Description
0	0	0: GPO inactive (LED off)
	1	1: GPO active (LED on)
1	0	No function
	1	Output is changed at end of reference run

Table 6.7: Output adjustment

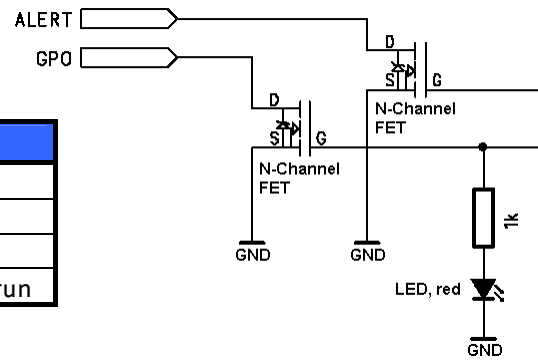

Figure 6.2: Alarm and GPO

6.2.1.8 Set Position (P), Read Current Position (R)

The position value of the motor can be changed by the command "P". When changing this value just the motors positioning counter is changed. The motor does no according movement. The actual position can be read out by the command 'R'.

6.2.1.9 I/Os Readout (Q)

Command:

AQ ⇒ ENTER

Bit	7	6	5	4	3	2	1	0
Port	0	0	0	GPI	REF_A	REF_B	GPO	ALARM

Table 6.8: I/Os Readout

6.2.1.10 Baud Rate (U)

The parameter 'U' changes the baud rate of the module for RS485 communication.

Parameter U	Baud rate
0	9600 baud
1	14400 baud
2	19200 baud
3	28800 baud
4	38400 baud
5	57600 baud
6	76800 baud
7	115200 baud

Table 6.9: Baud rate

6.2.1.11 Velocity Mode (V)

The velocity mode allows rotation of the motor without external signals. In order to rotate the motor, please set an acceleration value different from zero. The velocity is given by the following equation, when parameter "n" is used:

$$v[\text{microsteps / s}] = n \cdot 0.149157 [\text{microsteps / s}]$$

$$v[\text{steps / s}] = \frac{n \cdot 0.149157}{\text{Microstep resolution}} [\text{steps / s}]$$

$$v[\text{rotations / s}] = \frac{n \cdot 0.149157}{\text{Microstep resolution} \cdot \text{Fullsteps of motor}} [\text{rotations / s}]$$

For a 200 step motor at 64 microsteps, this gives

$$v[\text{rotations / s}] = \frac{n}{85815} [\text{rotations / s}]$$

A practical limit with most stepper motor types is about 20 rotations / second in chopper mode 0 and 5 rotations / second in chopper mode 2.

As a second parameter, value "0" or "1" is optional. Standard is 0 and sends back the Carriage Return character at once. If it is set to "1" sending back of the Carriage Return character is delayed until the target velocity is reached.

Example:

AV -50000 ⇒ ENTER: Accelerates motor to given velocity

AV 0 1 ⇒ ENTER: Accelerates motor to velocity zero (standstill) and delays echoing of carriage return until target velocity has been reached

6.2.1.12 Store Parameters to EEPROM (W)

This command stores different parameters to the EEPROM to restart with the same performance after power down.

The stored parameters are:

- Current setting (C)
- Selected Mode (M)
- Alert adjustments (N)
- Output adjustments (O)
- RS485 parameters (U)
- Microstep resolution (Z)

6.2.1.13 Microstep Resolution (Z)

The microstep resolution can be set by the user. It depends on the maximum resolution which differs in the three chopper modes (see 6.2.2).

The maximum resolution is divided by the parameter 'Z'.

Parameter Z		Microstep resolution		
		SPI	PWM	Phase (default)
0	max resolution	64 *)	64	256
1	1/2 max	32 **)	32	128
2	1/4 max	16	16	64
3	1/8 max	8	8	32
4	1/16 max	4	4	16
5	1/32 max	2	2	8
6	1/64 max	1	1	4

Table 6.10: Adjustment of Microstep Resolution

*) Simulated microsteps, the actual microsteps of the motor are not improved.

***) Simulated microsteps, the actual microsteps are improved but do not reach 32 microsteps.

Example:

AZ 2 ⇒ ENTER : Sets the microstep resolution to a quarter of the maximum resolution.

6.2.2 Chopper Modes

6.2.2.1 Chopper Mode 0 (SPI) / Default Mode

In this mode, the motor coil current is regulated on a chopper-cycle-by chopper-cycle bias. This is the standard operation mode for most motor drivers. It brings a medium microstep resolution of 16 microsteps and typically works good with most motors and a high range of supply voltage and motor current settings. A resolution of up to 64 microsteps can be simulated but the motor precision is only slightly improved compared to 16 microsteps and the same as with 32 microsteps.

The maximum supply voltage (V_S) of the motor must not exceed 22-25 times the nominal motor voltage (V_N), regarding the multiplication of $I_{COIL, MAX}$ and R_{MOTOR} . A higher value would lead to an excess of motor rating.

The minimum supply voltage has to be above two times the nominal motor voltage.

$$2 \cdot V_N \leq V_S \leq 22 \dots 25 \cdot V_N$$

$$V_N = I_{COIL, MAX} \cdot R_{MOTOR}$$

It uses a chopper frequency of about 36kHz.

6.2.2.2 Chopper Mode 1 (PWM)

This mode is identical to the SPI mode, but it increases the microstep resolution at low velocities / stand still.

$$2 \cdot V_N \leq V_S \leq 22 \dots 25 \cdot V_N$$

$$V_N = I_{COIL, MAX} \cdot R_{MOTOR}$$

6.2.2.3 Chopper Mode 2 (PHASE)

This mode uses a different chopper scheme, which provides a very high microstep resolution and smooth motor operation. Care has to be taken concerning the selection of motor and supply voltage: The motor is chopped with 20kHz, and the coil sees a 50% duty cycle at full supply voltage when the coil current is meant to be zero. This is only true for the average, but the motor still sees an alternating current and thus an alternating magnetic field. Now, care has to be taken in order to keep this current to a value which is significantly lower than the motor maximum coil current. If it is too high, the motor has significant magnetization losses and coil power dissipation, and would get much too hot, even with zero average current. The only possibility to limit this effect, is to operate with a comparatively low supply voltage.

Check list:

Please take the motor inductivity L [mH] and motor rated full step coil current I_{COIL} [A] from the motor's data sheet:

Now choose a supply voltage for the module to fulfill the following comparison:

$$\frac{V_S \cdot 25\mu s}{L} \leq I_{COIL} \cdot 0.5$$

$$\Leftrightarrow V_S \leq I_{COIL} \cdot 20k \cdot L$$

If your parameters do not fulfill the equation, i.e. you calculate a supply voltage which is below the modules' operation specs or which does not fit your system requirements, try the following:

Calculate x:

$$x = \frac{V_s}{I_{COIL}} \cdot \frac{0.025}{L[mH]}$$

If x is below 0.5, everything is OK.

If x is in the range 0.5 to 1.0, try operating your motor and check if motor or driver gets too hot.

If x is above 1.0, choose one of the other chopper modes.

See also chapter 5.2.1.3 for graphical demonstration.

6.2.2.4 Chopper mode 3 (Phase and SPI)

This mode combines the modes 2 (Phase) and 0 (SPI) in order to provide highest accuracy at lower velocities and also the possibility for faster movements. Through the switching between modes some microsteps may be lost. Microstep resolution must not be higher than 64. It is set according to Phase mode, so possible values for Z (microstep resolution) are 2, 3 or 4.

μ-steps	Phase to SPI		SPI to Phase	
	V-value	Rounds/s	V-value	Rounds/s
64	192000	2.24	25000	0.29
32	96000	2.24	12500	0.29
16	48000	2.24	6250	0.29

Table 6.11: Chopper mode 3 switching velocities

Conversion of values above to motors with different fullstep resolutions:

$$v_{motor} (\text{rounds/s}) = \frac{v_{table} (\text{rounds/s})}{200} \cdot \text{motors fullsteps per revolution}$$

6.2.2.5 Chopper mode 4 (PWM and SPI)

This mode combines the modes 1 (PWM) and 0 (SPI) in order to provide higher accuracy (up to 64 microsteps) at lower velocities and also the possibility for faster movements. For higher velocities in SPI mode the microstep resolution is always 16, but set resolution is simulated. Through the switching between modes some microsteps may be lost. Microstep resolution must not be higher than 64. It is set according to Phase mode, so possible values for Z (microstep resolution) are 2, 3 or 4. This mode should only be used in very special occasions and mode 3 should be preferred if a combination of high accuracy at slow movements and high speed is needed.

6.3 Step / Direction

Additional Parameters can be set by RS485 i.e. to set a maximum velocity or microsteps per round.

The Step-Direction controls are as follows:

Motor	Velocity	Acceleration	Rotate right	Rotate left
Control	Step frequency	Increase or decrease of Step frequency	Direction open wired or connected to V_{COM}	Direction connected to Ground

Table 6.12: External signals and motor reactions

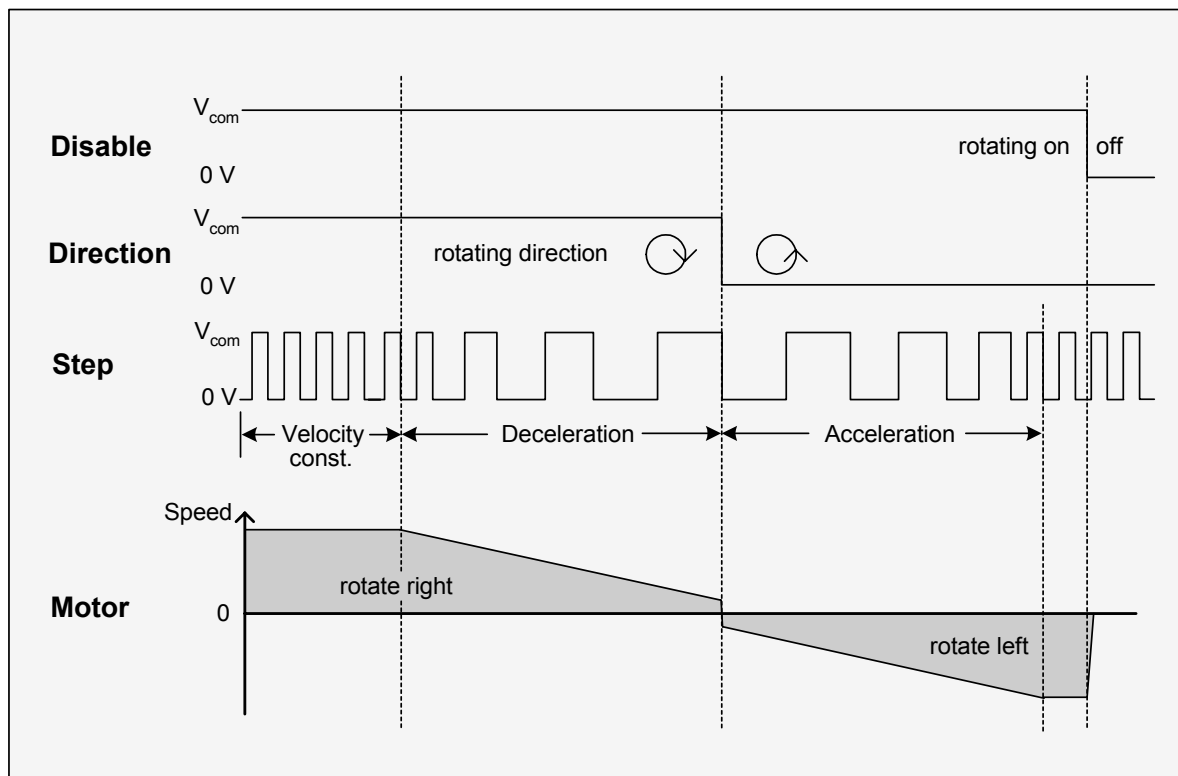

Figure 6.3: Step-Direction signals and motor reactions

6.3.1 Direction

Description: The Direction signal changes the motors rotation from clockwise (CW) to counterclockwise (CCW) and vice versa.

Function Table:

GND	open wire	$V_{COM} = 5...24V$
motor CW	motor CCW turn	

6.3.2 Step

Description: The Step signal controls the velocity and acceleration of the motor. The velocity depends on the frequency, the acceleration on the change of the frequency. One step impulse represents one microstep.

Calculation of rotations per second (refer to 6.2.1.13):

$$v[\text{rotations / s}] = \frac{\text{Step input frequency}}{\text{Fullsteps} \cdot \text{Microstep resolution}} [\text{rotations / s}]$$

Frequency: The maximum Step input frequency is 350 kHz, aligned to the Direction signal. The minimum logic "0" time is 0.7 μs and the minimum logic "1" time is 2.0 μs . A step is triggered by the positive going edge of the signal (switching off of opto coupler).

Function Table:

Extern	GND	open wire	$V_{COM} = 5...24V$
Intern	HIGH	LOW	

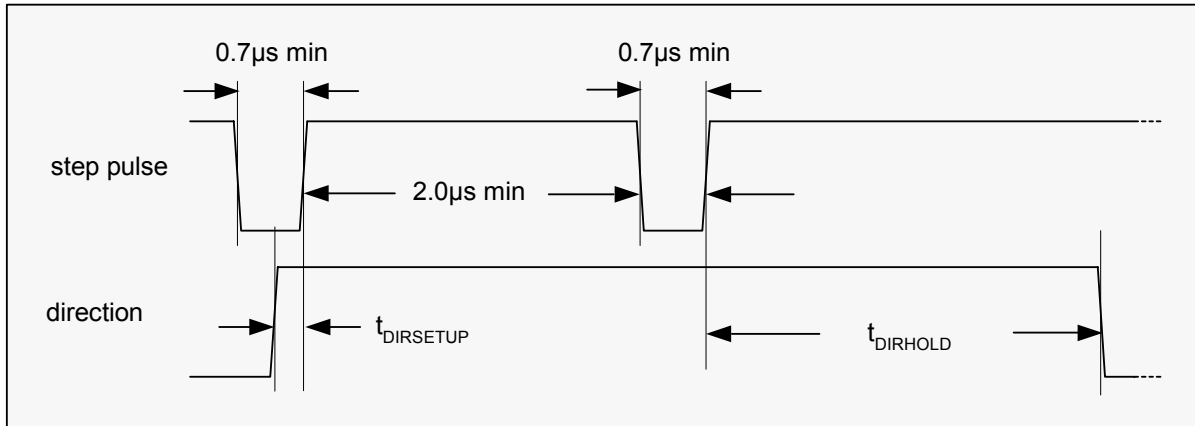

Figure 6.4: Step and Direction Signal

6.4 Firmware Update

For Firmware update start the program TMCM013boot.exe contained in the TMCM-013-Folder of your TMCTechLibCD or at www.trinamic.com:

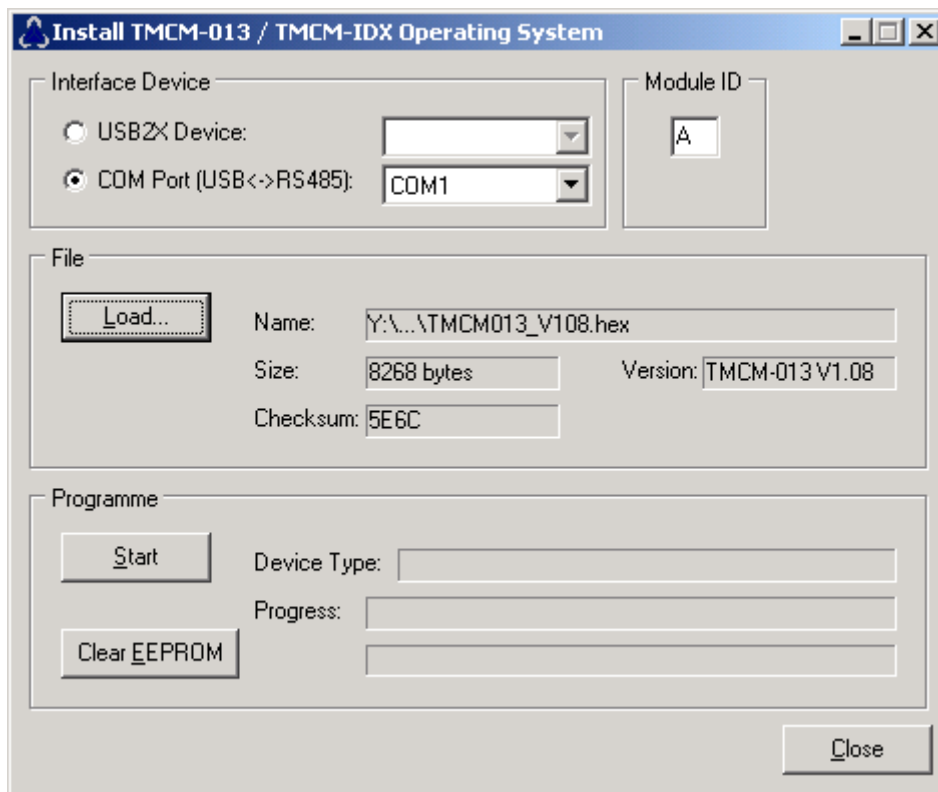

Figure 6.5: Firmware update tool

1. Choose your RS485 connection.
2. Select your Module ID (default is A).
3. Load the new firmware file (e.g. TMCM013_V1.08.hex), to download from www.trinamic.com.
4. Start the update process.

At the end of the update process check your firmware version with command "AX".

6.5 Reset to factory default

When the baud rate or the address of a module is not known, it makes sense to restore factory default settings. To do this, switch off the module and short-circuit pin 1 and pin 3 of the free contacts for a 6-pin connector on the backside of the module. See Figure 6.6. Turn on the module and switch it off again to remove the short-circuit. All settings are now at factory default.

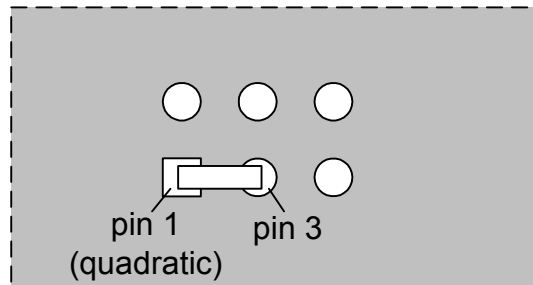

Figure 6.6: Reset to factory default

6.6 Option: Pseudo DC-Motor mode (not supported by software yet)

The velocity of the motor in this mode is changed through a constant voltage at the General Purpose input. The operational voltage is 7...28V. *This option may be available in a future firmware version.*

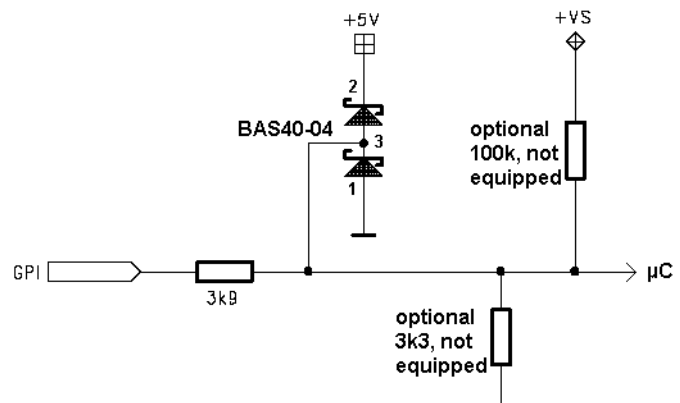

Figure 6.7: GPI wiring scheme

6.6.1 Changes required for DC motor mode operation

It is advised to connect an external voltage divider to the GPI pin, as depicted.

However, there are two free places for 0805 SMD resistors to be equipped directly on the module TMC013.

To enable this mode solder resistors as follows:

Attention: Do not try to make changes on the board until you are absolutely sure.

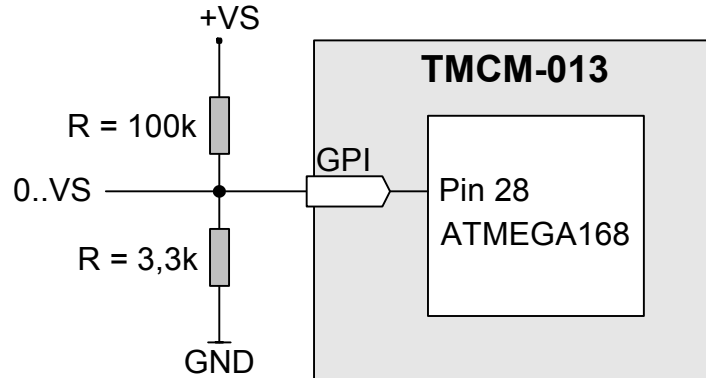
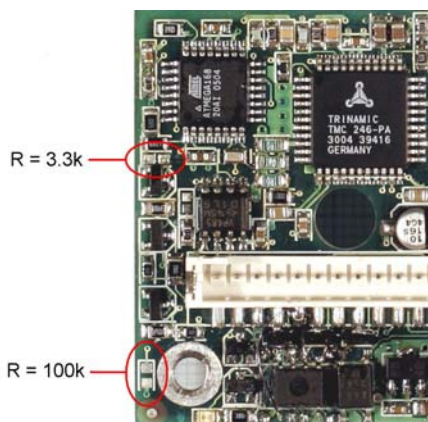
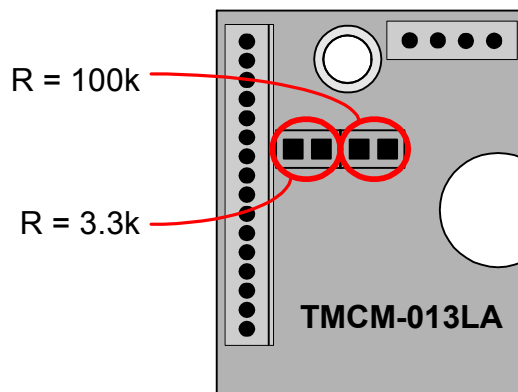

Figure 6.8: External Changes for act like DC-Motor option



TMCM-013



TMCM-013-LA

Keep in mind: This changes can be made externally also.

6.6.2 Parameterizing with RS485

First set parameters for minimum voltage, maximum voltage and a zero point in between. Other values can be changed also like max. acceleration, max. velocity, microsteps, ...

Before enabling this mode *with the appropriate RS485 command ...* connect a voltage of 7...28V to General Purpose Input (GPI). The voltage has to exceed zero point voltage before the regulation works.

6.6.3 Motion Control

Change the voltage at GPI between 7...28V. The motor will accelerate and decelerate relative to the specified zero point. Additional parameters like resolutions of microsteps can be stored in the EEPROM.

7 Revision History

7.1 Documentation Revision

Version	Comment	Author	Description
1.10	First Release	HC	Full functionality for Firmware V1.05
1.11	PD-release	BD	Includes PANdrive order codes
1.12	Limit switch	HC	Added Limit switch documentation
1.13	Updates	HC	StallGuard added with RS485 command 'G', formerly used for output setting (LED) now command 'O'. Switched default mode to SPI.
1.15	Updates	HC	RS485 connection documentation revised
1.16	Updates	HC	Power Supply Requirements, Velocity Mode, Modes 3 and 4, GPO, GPI wiring scheme included
1.17	Updates	HC	Firmware update included
1.18	Corrections	HC	Step / direction timing
1.19	Corrections	HC	5.2.1.3 Chopper Mode 2 – Inductivities, 6.2.1.13 Microstep Resolution

Table 7.1: Documentation Revisions

7.2 Firmware Revision

Version	Comment	Description
1.05	Pls. update	
1.07	Bug fix	Full functionality (except DC-Motor) with some possibilities to expand
1.08	Bug fix, new options	Added chopper modes 3 and 4, modified V command, corrected RS485 bug (always echoing of CR at earlier versions)

Table 7.2: Firmware Revisions