



EVERLIGHT ELECTRONICS CO.,LTD.

Device Number : DLE-026-319 REV: 1.0

3mm Round Small Flange Without stand-off LEDs, T-1

MODEL NO : 264-7SYGC/S530-E2 ECN : _____ Page: 1/4

Features :

- High luminous power.
- Can be driven at low current.
- 2.54mm lead spacing.
- Available on tape and reel.

Description :

- The series is specially designed for applications require higher brightness than that achievable with standard lamp.
- The LED lamps are available with different colors,intensities, epoxy colors, etc.

Package Dimension:

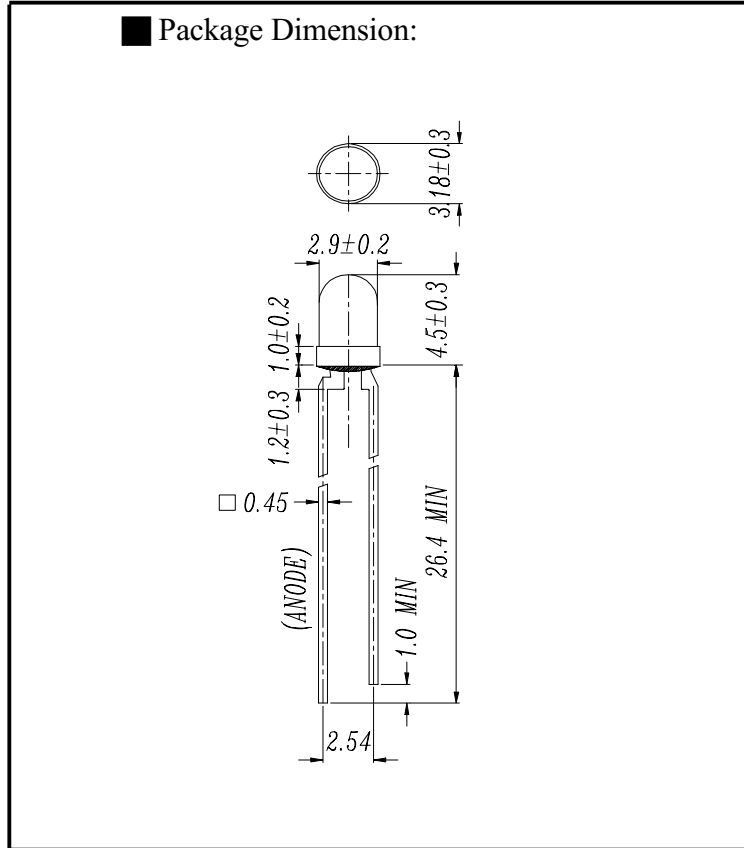

Applications :

- TV Set
- Monitor
- Telephone
- Computer

NOTES :

- 1.All dimensions are in millimeters.
- 2.An epoxy meniscus may extend about 1.5mm(0.059") down to the lead.

PART NO	CHIP		Lens Color
	Material	Emitted Color	
264-7SYGC/S530-E2	AlGaInP	Super Yellow Green	Water Clear

DESIGNER	CHECKER	APPROVER

Office : NO 25,Lane 76,Chung Yang Rd,Sec.3
Tucheng,Taipei 236,Taiwan,R.O.C.

TEL : 886-2-2267-2000,2267-9936(22 Lines)
FAX : 886-2-2267-6189



EVERLIGHT ELECTRONICS CO.,LTD.

Device Number : DLE-026-319 REV: 1.0

3mm Round Small Flange Without stand-off LEDs, T-1

MODEL NO : 264-7SYGC/S530-E2 ECN : Page: 2/4

■ Absolute Maximum Ratings at T_A = 25°C

Parameter	Symbol	Rating	Unit
Forward Current	I _f	25	mA
Operating Temperature	T _{opr}	-40 to +85	°C
Storage Temperature	T _{stg}	-40 to +100	°C
Soldering Temperature	T _{sol}	260 ± 5	°C
Power Dissipation	P _d	60	mW
Peak Forward Current(Duty 1/10 @ 1KHZ)	I _f (Peak)	160	mA
Reverse Voltage	V _r	5	V

■ Electronic Optical Characteristics :

Parameter	Symbol	MIN.	TYP.	MAX.	Unit	Condition
Luminous intensity	I _v	----- 70	6.0 100	----	mcd	I _f =2mA I _f =20mA
Viewing Angle	2θ 1/2	----	40	----	deg	I _f =20mA
Peak Wavelength	λ _p	----	575	----	nm	I _f =20mA
Dominant Wavelength	λ _d	----	573	----	nm	I _f =20mA
Spectrum Radiation Bandwidth	△λ	----	20	----	nm	I _f =20mA
Forward Voltage	V _f	----	2.0	2.4	V	I _f =20mA
Reverse Current	I _r	----	----	10	μA	V _r =5V



3mm Round Small Flange Without stand-off LEDs, T-1

■ Typical Electro-Optical Characteristic Curves

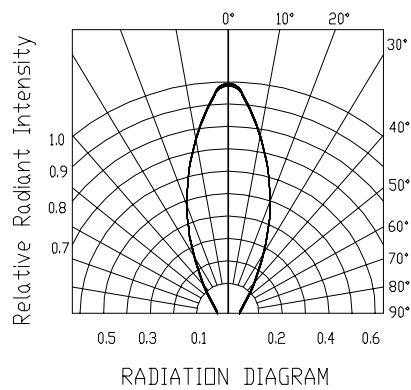
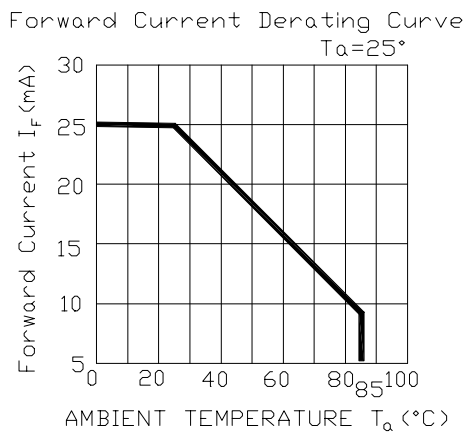
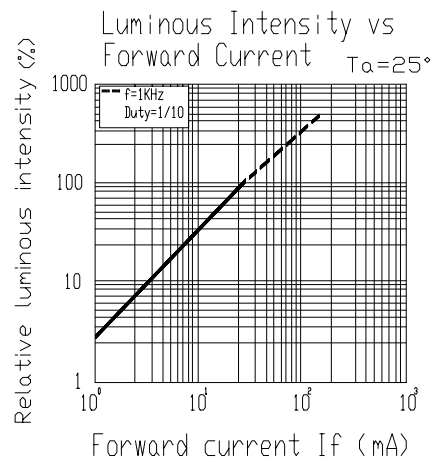
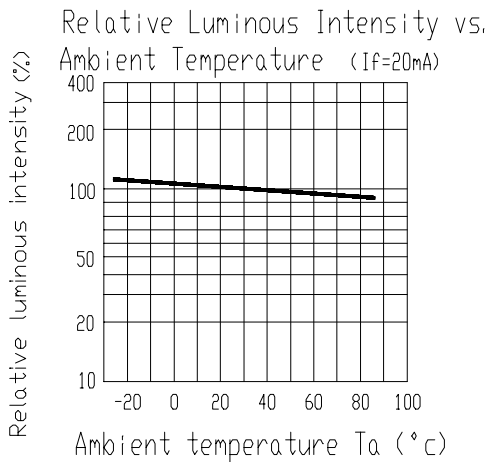
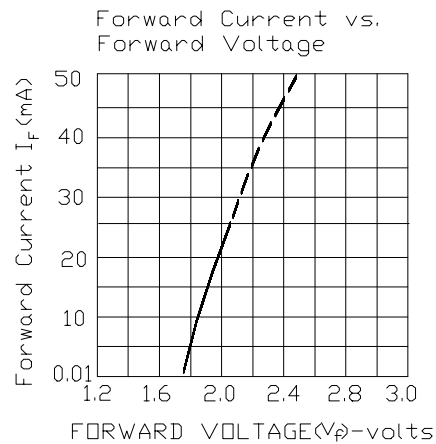
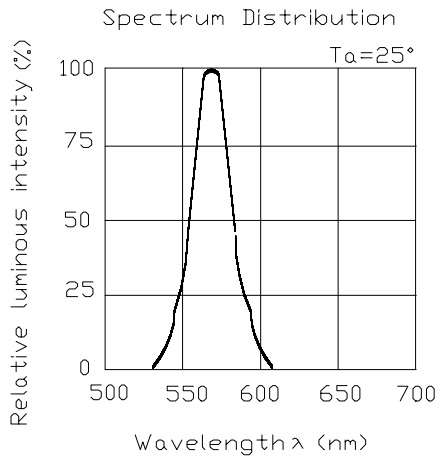



EVERLIGHT ELECTRONICS CO.,LTD.

Device Number : DLE-026-319REV: 1.0

3mm Round Small Flange Without stand-off LEDs, T-1

MODEL NO 264-7SYGC/S530-E2 ECN : Page: 4/4

■ Reliability test items and conditions

NO	Item	Test Conditions	Test Hours/Cycle	Sample Size	Ac/Re
1	Soldering Heat	TEMP : 260°C ± 5 °C	10±1 SEC	76 Pcs	0/1
2	Solderability	TEMP : 230°C ± 5 °C	5±1 SEC	76 Pcs	0/1
3	Temperature Cycle	H : +85°C 30min ∫ 5 min L : -55°C 30min	50 CYCLE	76 Pcs	0/1
4	Thermal Shock	H : +100°C 5min ∫ 10 sec L : -10°C 5min	50 CYCLE	76 Pcs	0/1
5	High Temperature Storage	TEMP : 100°C	1000 HRS	76 Pcs	0/1
6	Low Temperature Storage	TEMP : -55°C	1000 HRS	76 Pcs	0/1
7	DC Operating Life	If = 20 mA	1000 HRS	76 Pcs	0/1
8	High Temperature / High Humidity	85°C/85% RH	1000 HRS	76 Pcs	0/1