

KOE

JDI Group

Kaohsiung Opto-Electronics Inc.

FOR MESSRS : _____

DATE : Jun. 8th ,2012

CUSTOMER'S ACCEPTANCE SPECIFICATIONS

TX17D02VM2CAA

Contents

| No. | ITEM | SHEET No. | PAGE |
|-----|----------------------------|-----------------------------|------------|
| 1 | COVER | 7B64PS 2701-TX17D02VM2CAA-3 | 1-1/1 |
| 2 | RECORD OF REVISION | 7B64PS 2702-TX17D02VM2CAA-3 | 2-1/1 |
| 3 | GENERAL DATA | 7B64PS 2703-TX17D02VM2CAA-3 | 3-1/1 |
| 4 | ABSOLUTE MAXIMUM RATINGS | 7B64PS 2704-TX17D02VM2CAA-3 | 4-1/1 |
| 5 | ELECTRICAL CHARACTERISTICS | 7B64PS 2705-TX17D02VM2CAA-3 | 5-1/2~2/2 |
| 6 | OPTICAL CHARACTERISTICS | 7B64PS 2706-TX17D02VM2CAA-3 | 6-1/2~2/2 |
| 7 | BLOCK DIAGRAM | 7B64PS 2707-TX17D02VM2CAA-3 | 7-1/1 |
| 8 | RELIABILITY TESTS | 7B64PS 2708-TX17D02VM2CAA-3 | 8-1/1 |
| 9 | LCD INTERFACE | 7B64PS 2709-TX17D02VM2CAA-3 | 9-1/7~7/7 |
| 10 | OUTLINE DIMENSIONS | 7B64PS 2710-TX17D02VM2CAA-3 | 10-1/2~2/2 |
| 11 | APPEARANCE STANDARD | 7B64PS 2711-TX17D02VM2CAA-3 | 11-1/3~3/3 |
| 12 | PRECAUTIONS | 7B64PS 2712-TX17D02VM2CAA-3 | 12-1/2~2/2 |
| 13 | DESIGNATION OF LOT MARK | 7B64PS 2713-TX17D02VM2CAA-3 | 13-1/1 |

ACCEPTED BY: _____

PROPOSED BY: 

2. RECORD OF REVISION

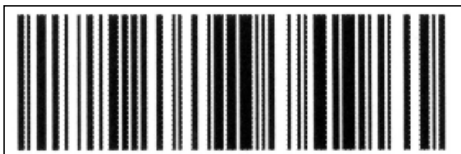
| DATE | SHEET No. | SUMMARY | | | | | | | | | | | | | | | | | | | |
|--|---|---|--------|------|---------|----------------------|-----|-----|------|-------------------------|----------|----------------------|-------------|-------------------|---------------|------------|-----------------------|----------------------|---------------|-------------------|---------------|
| May 01,'12 | All pages | Company name changed: KAOHSIUNG HITACHI ELECTRONICS CO.,LTD. ↓ KAOHSIUNG OPTO-ELECTRONICS INC. | | | | | | | | | | | | | | | | | | | |
| | 7B64PS-2704- TX17D02VM2CAA-2 Page 4-1/1 | 4. ABSOLUTE MAXIMUM RATINGS Revised: Note2. | | | | | | | | | | | | | | | | | | | |
| Jun. 08,'12 | 7B64PS-2703- TX17D02VM2CAA-3 Page 3-1/1 | 3.1 DISPLAY FEATURES Revised : Power Consumption : 0.48 W for LCD → 0.64 W for LCD | | | | | | | | | | | | | | | | | | | |
| | 7B64PS-2705- TX17D02VM2CAA-3 Page 5-1/2 | 5.1 LCD CHARACTERISTICS Revised : <table border="1"> <thead> <tr> <th>Item</th> <th>Typ.</th> <th>Max.</th> </tr> </thead> <tbody> <tr> <td>Power Supply Current</td> <td>145</td> <td>174</td> </tr> </tbody> </table> ↓ <table border="1"> <thead> <tr> <th>Item</th> <th>Typ.</th> <th>Max.</th> </tr> </thead> <tbody> <tr> <td>Power Supply Current</td> <td>193</td> <td>231</td> </tr> </tbody> </table> | Item | Typ. | Max. | Power Supply Current | 145 | 174 | Item | Typ. | Max. | Power Supply Current | 193 | 231 | | | | | | | |
| Item | Typ. | Max. | | | | | | | | | | | | | | | | | | | |
| Power Supply Current | 145 | 174 | | | | | | | | | | | | | | | | | | | |
| Item | Typ. | Max. | | | | | | | | | | | | | | | | | | | |
| Power Supply Current | 193 | 231 | | | | | | | | | | | | | | | | | | | |
| 7B64PS-2713- TX17D02VM2CAA-3 Page 13-1/1 | | 13. DESIGNATION of LOT MARK Added : | | | | | | | | | | | | | | | | | | | |
| | | <table border="1"> <thead> <tr> <th>REV.No</th> <th>ITEM</th> <th>REMARKS</th> </tr> </thead> <tbody> <tr> <td>-</td> <td>-</td> <td>-</td> </tr> <tr> <td>A</td> <td>DC/DC converter changed</td> <td>PCN 0850</td> </tr> </tbody> </table> Revised : <div style="text-align: center;">  <table border="0"> <tr> <td>TX17D02VM2CAA</td> <td>REV:</td> </tr> <tr> <td>9044T (5D)</td> <td>005373</td> </tr> <tr> <td>KOE</td> <td>MADE IN TAIWAN</td> </tr> </table> ↓  <table border="0"> <tr> <td>TX17D02VM2CAA</td> <td>REV: A</td> </tr> <tr> <td>9044T (5E)</td> <td>005373</td> </tr> <tr> <td>KOE</td> <td>MADE IN TAIWAN</td> </tr> </table> </div> | REV.No | ITEM | REMARKS | - | - | - | A | DC/DC converter changed | PCN 0850 | TX17D02VM2CAA | REV: | 9044T (5D) | 005373 | KOE | MADE IN TAIWAN | TX17D02VM2CAA | REV: A | 9044T (5E) | 005373 |
| REV.No | ITEM | REMARKS | | | | | | | | | | | | | | | | | | | |
| - | - | - | | | | | | | | | | | | | | | | | | | |
| A | DC/DC converter changed | PCN 0850 | | | | | | | | | | | | | | | | | | | |
| TX17D02VM2CAA | REV: | | | | | | | | | | | | | | | | | | | | |
| 9044T (5D) | 005373 | | | | | | | | | | | | | | | | | | | | |
| KOE | MADE IN TAIWAN | | | | | | | | | | | | | | | | | | | | |
| TX17D02VM2CAA | REV: A | | | | | | | | | | | | | | | | | | | | |
| 9044T (5E) | 005373 | | | | | | | | | | | | | | | | | | | | |
| KOE | MADE IN TAIWAN | | | | | | | | | | | | | | | | | | | | |

3. GENERAL DATA

3.1 DISPLAY FEATURES

This module is a 6.5" VGA of 4:3 format amorphous silicon TFT. The pixel format is vertical stripe and sub pixels are arranged as R (red), G (green), B (blue) sequentially. This display is RoHS compliant, COG (chip on glass) technology and LED backlight are applied on this display.

| | |
|-------------------------|--|
| Part Name | TX17D02VM2CAA |
| Module Dimensions | 153.0(W) mm x 118.0(H) mm x 9.1(D) mm typ. |
| LCD Active Area | 132.48(W) mm x 99.36(H) mm |
| Pixel Pitch | 0.207(W) mm x 0.207(H) mm |
| Resolution | 640 x 3(RGB)(W) x 480(H) dots |
| Color Pixel Arrangement | R, G, B Vertical stripe |
| LCD Type | Transmissive Color TFT; Normally White |
| Display Type | Active Matrix |
| Number of Colors | 262k Colors |
| Backlight | LED (Lifetime: 70 Khr) |
| Weight | 190g typ. |
| Interface | LVDS; 20 pins |
| Power Supply Voltage | 3.3V for LCD; 12V for Backlight |
| Power Consumption | 0.64W for LCD; 4.08W for backlight |
| Viewing Direction | 12 O'clock (without image inversion and least brightness change) 6 O'clock (contrast peak located at) |

4. ABSOLUTE MAXIMUM RATINGS

| Item | Symbol | Min. | Max. | Unit | Remarks |
|-------------------------|--------|------|---------|------|---------|
| Supply Voltage | VDD | -0.3 | 5.0 | V | - |
| Input Voltage of Logic | VI | -0.2 | VDD+0.3 | V | Note 1 |
| Operating Temperature | Top | -20 | 70 | °C | Note 2 |
| Storage Temperature | Tst | -30 | 80 | °C | Note 2 |
| Backlight Input Voltage | VLED | - | 15 | V | - |

Note 1: The rating is defined for the signal voltages of the interface such as CLK and pixel data pairs.

Note 2: The maximum rating is defined as above based on the chamber temperature, which might be different from ambient temperature after assembling the panel into the application. Moreover, some temperature-related phenomenon as below needed to be noticed:

- Background color, contrast and response time would be different in temperatures other than 25°C.
- Operating under high temperature will shorten LED lifetime.

5. ELECTRICAL CHARACTERISTICS

5.1 LCD CHARACTERISTICS

$T_a = 25\text{ }^\circ\text{C}$, $V_{SS} = 0\text{V}$

| Item | Symbol | Condition | Min. | Typ. | Max. | Unit | Remarks |
|--|-----------|------------------|-------|------|------|------|----------|
| Power Supply Voltage | VDD | - | 3.0 | 3.3 | 3.6 | V | - |
| Differential Input Voltage for LVDS Receiver Threshold | VI | VIH | - | - | +100 | mV | Note 1 |
| | | VIL | -100 | - | - | | |
| Power Supply Current | IDD | VDD-VSS =3.3V | - | 193 | 231 | mA | Note 2,3 |
| Vsync Frequency | f_v | - | - | 60 | 66 | Hz | Note 4 |
| Hsync Frequency | f_H | - | 29.72 | 31.5 | 34.2 | KHz | |
| DCLK Frequency | f_{CLK} | - | 22.29 | 25.2 | 34.2 | MHz | |

Note 1: VCM=+1.2V

VCM is common mode voltage of LVDS transmitter/receiver.

The input terminal of LVDS transmitter is terminated with 100Ω.

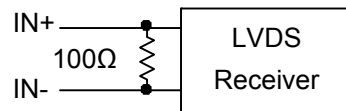

Note 2: An all black check pattern is used when measuring I_{DD} , f_v is set to 60Hz.

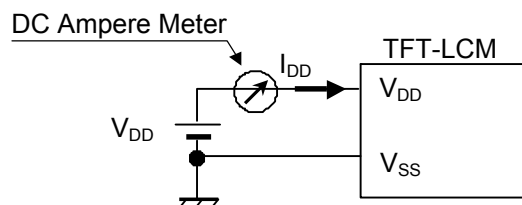

Note 3: 1.0A fuse is applied in the module for I_{DD} . For display activation and protection purpose, power supply is recommended larger than 2.5A to start the display and break fuse once any short circuit occurred.

Note 4: For LVDS transmitter input.

5.2 BACKLIGHT CHARACTERISTICS

$T_a = 25^\circ\text{C}$

| Item | Symbol | Condition | Min. | Typ. | Max. | Unit | Remarks |
|--------------------------------------|--------|-------------------|------|------|------|------|---------|
| LED Input Voltage | VLED | - | 11.7 | 12 | 12.3 | V | Note1 |
| LED Forward Current (Dim Control) | ILED | 0V; 0% duty | 320 | 340 | 360 | mA | Note 2 |
| | | 3.3VDC; 100% duty | 24 | 30 | 36 | | |
| LED lifetime | - | 340 mA | - | 70K | - | hrs | Note 3 |

Note 1: As Fig. 5.1 shown, LED current is constant, 340 mA, controlled by the LED driver when applying 12V VLED.

Note 2: Dimming function can be obtained by applying DC voltage or PWM signal from the display interface CN1. The recommended PWM signal is 1K ~ 10K Hz with 3.3V amplitude.

Note 3: The estimated lifetime is specified as the time to reduce 50% brightness by applying 340 mA at 25°C .

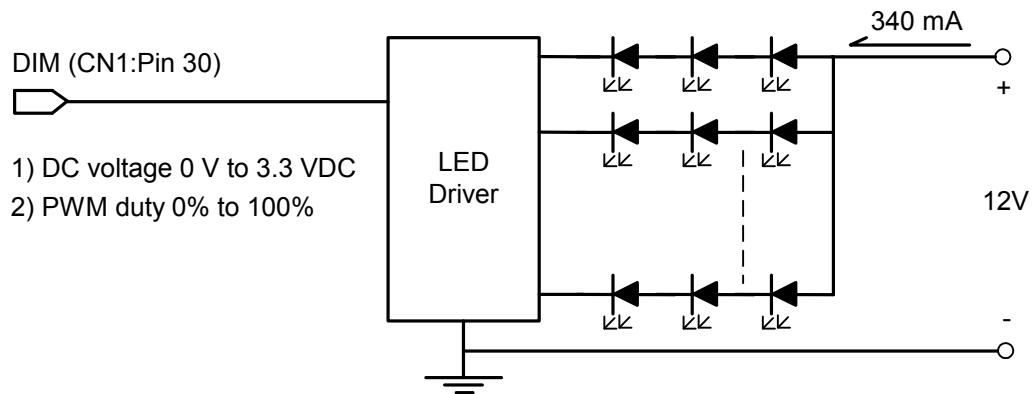

Fig 5.1

6. OPTICAL CHARACTERISTICS

The optical characteristics are measured based on the conditions as below:

- Supplying the signals and voltages defined in the section of electrical characteristics.
- The backlight unit needs to be turned on for 30 minutes.
- The ambient temperature is 25 °C .
- In the dark room around 500~1000 lx, the equipment has been set for the measurements as shown in Fig 6.1.

$$T_a = 25\text{ }^{\circ}\text{C}, f_v = 60\text{ Hz}, VDD = 3.3\text{V}$$

| Item | Symbol | Condition | Min. | Typ. | Max. | Unit | Remarks | |
|-------------------------------------|---------------------------------|--|--|------|------|-------------------|---------|--------|
| Brightness of White | - | $\phi = 0^{\circ}, \theta = 0^{\circ}$, ILED= 340 mA | 500 | 600 | - | cd/m ² | Note 1 | |
| Brightness Uniformity | - | | 70 | - | - | % | Note 2 | |
| Contrast Ratio | CR | | 300 | 600 | - | - | Note 3 | |
| Response Time (Rising + Falling) | T _r + T _f | $\phi = 0^{\circ}, \theta = 0^{\circ}$ | - | 30 | - | ms | Note 4 | |
| NTSC Ratio | - | $\phi = 0^{\circ}, \theta = 0^{\circ}$ | - | 50 | - | % | - | |
| Viewing Angle | θ_x | $\phi = 0^{\circ}, CR \geq 10$ | 70 | 80 | - | Degree | Note 5 | |
| | $\theta_{x'}$ | $\phi = 180^{\circ}, CR \geq 10$ | 70 | 80 | - | | | |
| | θ_y | $\phi = 90^{\circ}, CR \geq 10$ | 50 | 60 | - | | | |
| | $\theta_{y'}$ | $\phi = 270^{\circ}, CR \geq 10$ | 70 | 80 | - | | | |
| Color Chromaticity | Red | X | $\phi = 0^{\circ}, \theta = 0^{\circ}$ | 0.52 | 0.57 | 0.62 | - | Note 6 |
| | | Y | | 0.30 | 0.35 | 0.40 | | |
| | Green | X | | 0.29 | 0.34 | 0.39 | | |
| | | Y | | 0.50 | 0.55 | 0.60 | | |
| | Blue | X | | 0.09 | 0.14 | 0.19 | | |
| | | Y | | 0.06 | 0.11 | 0.16 | | |
| | White | X | | 0.25 | 0.30 | 0.35 | | |
| | | Y | | 0.26 | 0.31 | 0.36 | | |

Note 1: The brightness is measured from center point of the panel, P5 in Fig. 6.2, for the typical value.

Note 2: The brightness uniformity is calculated by the equation as below:

$$\text{Brightness uniformity} = \frac{\text{Min. Brightness}}{\text{Max. Brightness}} \times 100\%$$

, which is based on the brightness values of the 9 points measured by BM-5 as shown in Fig. 6.2.

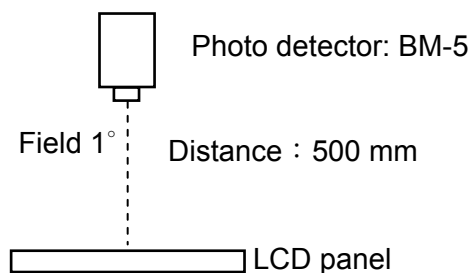

Fig. 6.1

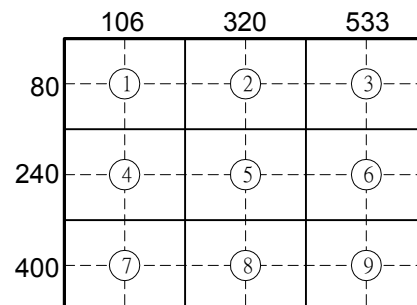

Fig. 6.2

Note 3: The Contrast ratio is measured from the center point of the panel, P5, and defined as the following equation:

$$CR = \frac{\text{Brightness of White}}{\text{Brightness of Black}}$$

Note 4: The definition of response time is shown in Fig. 6.3. The rising time is the period from 90% brightness to 10% brightness when the data is from white to black. Oppositely, falling time is the period from 10% brightness rising to 90% brightness.

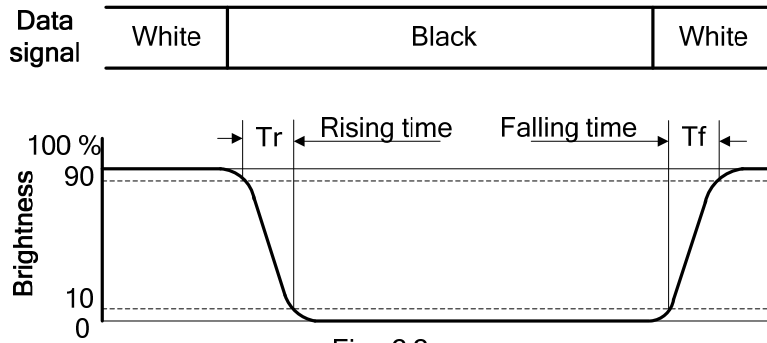

Fig . 6.3

Note 5: The definition of viewing angle is shown in Fig. 6.4. Angle ϕ is used to represent viewing directions, for instance, $\phi = 270^\circ$ means 6 o'clock, and $\phi = 0^\circ$ means 3 o'clock. Moreover, angle θ is used to represent viewing angles from axis Z toward plane XY.

The viewing direction of this display is 12 o'clock, which means that a photograph with gray scale would not be reversed in color and the brightness change would be less from this direction. However, the best contrast peak would be located at 6 o'clock.

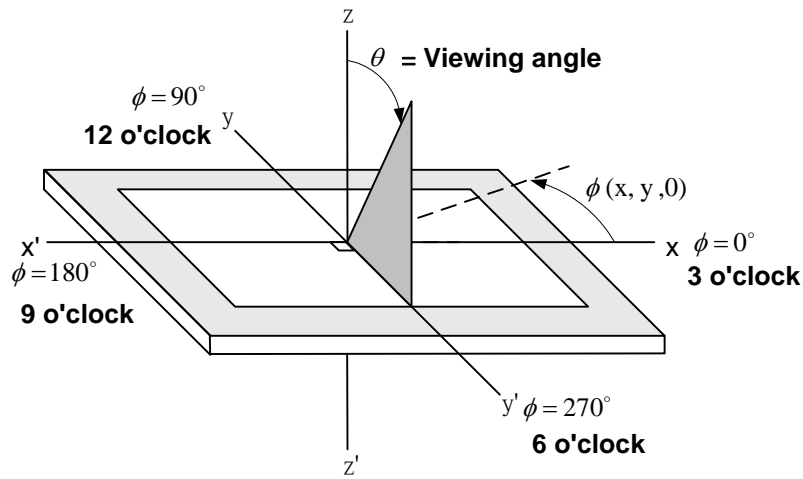
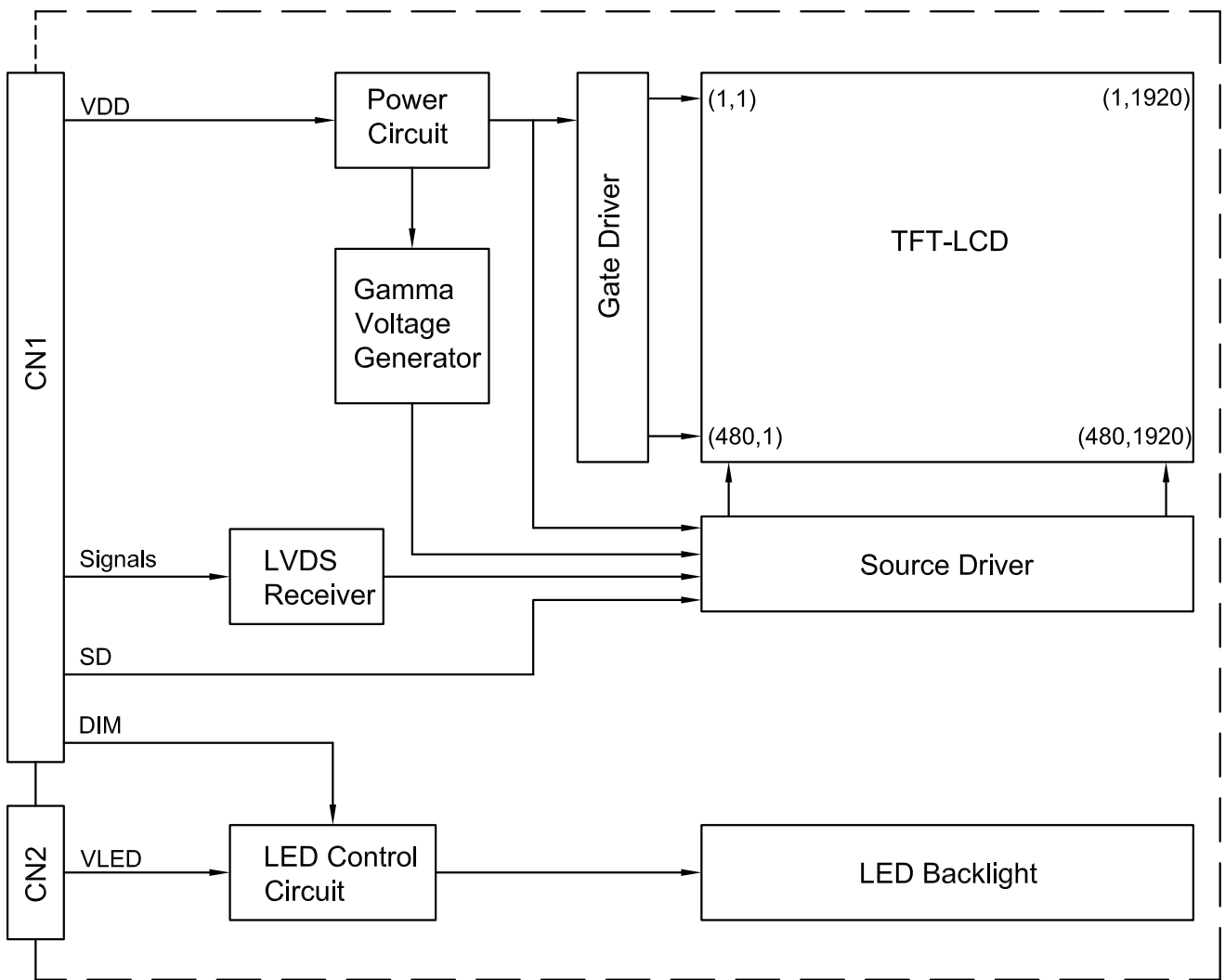

Fig. 6.4

Note 6: The color chromaticity is measured from the center point of the panel, P5, as shown in Fig. 6.2.

7. BLOCK DIAGRAM



Note: Signals are CLK, and pixel data pairs.

8. RELIABILITY TESTS

| Test Item | Condition | |
|-----------------------------|---|---|
| High Temperature | 1) Operating 2) 70 °C | 240 hrs |
| Low Temperature | 1) Operating 2) -20 °C | 240 hrs |
| High Temperature | 1) Storage 2) 80 °C | 240 hrs |
| Low Temperature | 1) Storage 2) -30 °C | 240 hrs |
| Heat Cycle | 1) Operating 2) -20 °C ~70 °C 3) 3hrs~1hr~3hrs | 240 hrs |
| Thermal Shock | 1) Non-Operating 2) -35 °C ↔ 85 °C 3) 0.5 hr ↔ 0.5 hr | 240 hrs |
| High Temperature & Humidity | 1) Operating 2) 40 °C & 85%RH 3) Without condensation (Note4) | 240 hrs |
| Vibration | 1) Non-Operating 2) 20~200 Hz 3) 2G 4) X, Y, and Z directions | 1 hr for each direction |
| Mechanical Shock | 1) Non-Operating 2) 10 ms 3) 50G 4) ±X, ±Y and ±Z directions | Once for each direction |
| ESD | 1) Operating 2) Tip: 200 pF, 250 Ω 3) Air discharge for glass: ± 8KV 4) Contact discharge for metal frame: ± 8KV | 1) Glass: 9 points 2) Metal frame: 8 points (Note3) |

Note 1: Display functionalities are inspected under the conditions defined in the specification after the reliability tests.

Note 2: The display is not guaranteed for use in corrosive gas environments.

Note 3: All pins of LCD interface (CN1) have been tested by ±100V contact discharge of ESD under non-operating condition.

Note 4: Under the condition of high temperature & humidity, if the temperature is higher than 40°C, the humidity needs to be reduced as Fig. 8.1 shown.

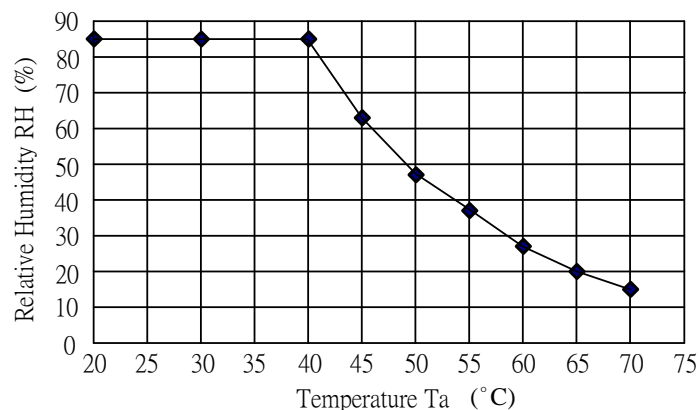

Fig. 8.1

9. LCD INTERFACE

9.1 INTERFACE PIN CONNECTIONS

The display interface connector (CN1) is FI-SEB20P-HF13E-E1500 made by JAE and pin assignment is as below:

| Pin No. | Symbol | Signal |
|---------|---------|--|
| 1 | VDD | Power Supply for Logic |
| 2 | VDD | |
| 3 | VSS | GND |
| 4 | VSS | |
| 5 | IN0- | R0~R5, G0 |
| 6 | IN0+ | |
| 7 | VSS | GND |
| 8 | IN1- | G1~G5, B0~B1 |
| 9 | IN1+ | |
| 10 | VSS | GND |
| 11 | IN2- | B2~B5, DE |
| 12 | IN2+ | |
| 13 | VSS | GND |
| 14 | CLK IN- | Pixel Clock |
| 15 | CLK IN+ | |
| 16 | VSS | GND |
| 17 | NC | No Connection |
| 18 | NC | |
| 19 | SD | Normal Scan: Low or Open Reverse Scan: High |
| 20 | DIM | Normal Brightness: 0V or 0% PWM Duty Brightness Control: 0V to 3.3 VDC or 0% to 100% PWM Duty |

Note 1: IN n- and IN n+ (n=0, 1, 2), CLK IN- and CLK IN+ should be wired by twist-pairs or side-by-side FPC patterns, respectively.

The backlight connector (CN2) is SM02(8.0)B-BHS-1-TB (LF)(SN) made by JST, and pin assignment is as below:

| Pin No. | Symbol | Signal |
|---------|--------|--------|
| 1 | VLED | 12VDC |
| 2 | GND | Ground |

9.2 LVDS INTERFACE

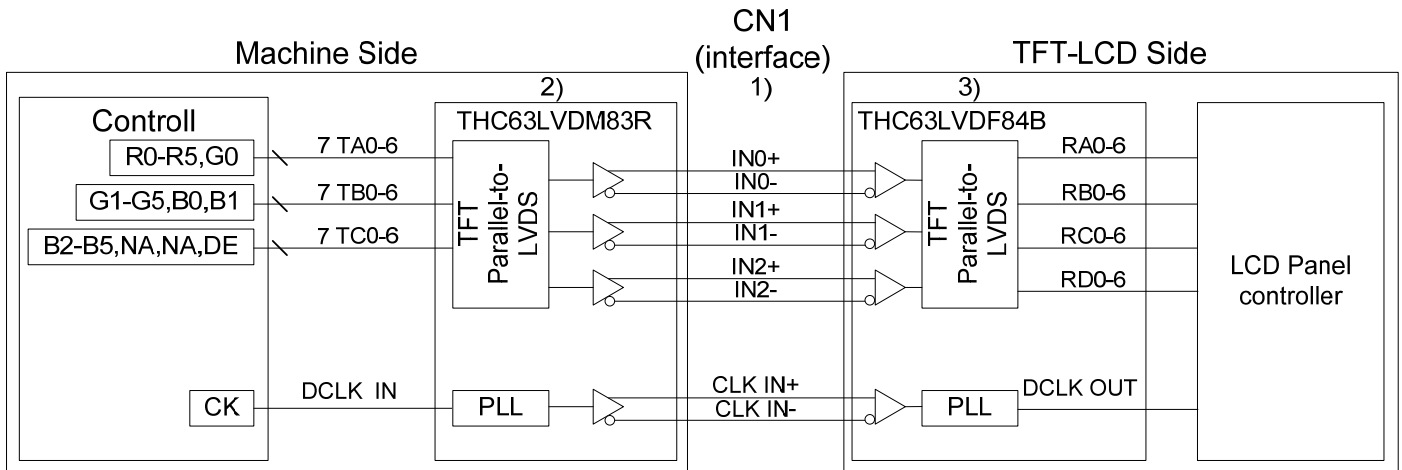

Note 1: LVDS cable impedance should be 100 ohms per signal line when each 2-lines (+, -) is used in differential mode.

Note 2: The recommended transmitter, THC63LVDM83R, is made by Thine or equivalent, which is not contained in the module.

Note 3: The receiver built-in the module is THC63LVDF84B made by Thine.

9.3 LVDS DATA FORMAT

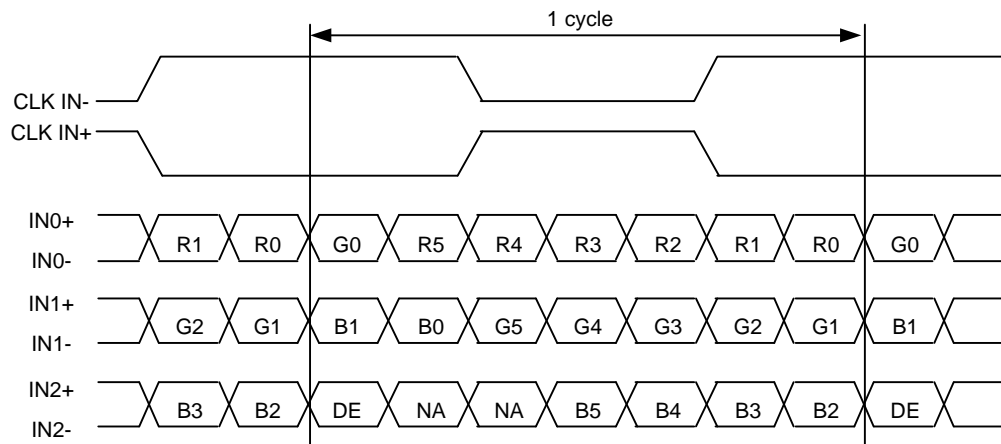

DE: Display Enable

NA: Not Available

9.4 INTERFACE TIMING SPECIFICATIONS

The column of timing sets including minimum, typical, and maximum as below are based on the best optical performance, frame frequency (Vsync) = 60 Hz to define. If 60 Hz is not the aim to set, less than 66 Hz for Vsync is recommended to apply for better performance by other parameter combination as the definitions in section 5.1.

| Item | | Symbol | Min. | Typ. | Max. | Unit |
|------|-----------------------------|----------------------|-------|------|------|-----------|
| DCLK | Cycle frequency | $1/t_{CLK}$ | 22.29 | 25.2 | 34.2 | MHz |
| | Low level width | t_{WCL} | 10 | - | - | ns |
| | High level width | t_{WCH} | 10 | - | - | |
| | Rise / Fall time | t_{rCLK}, t_{fCLK} | - | - | 12 | |
| | Duty | D | 0.4 | 0.5 | 0.6 | - |
| DTMG | Set up time | t_{SI} | 8 | - | - | ns |
| | Hold time | t_{HI} | 8 | - | - | |
| | Rise / Fall time | t_{r}, t_{f} | - | - | 12 | ns |
| | Horizontal cycle | t_H | 750 | 800 | 1000 | t_{CLK} |
| | Horizontal valid data width | t_{HD} | 640 | 640 | 640 | |
| | Horizontal porch width | t_{HB} | 110 | 160 | 360 | |
| | Vertical cycle | t_V | 495 | 525 | 570 | t_H |
| | Vertical valid data width | t_{VD} | 480 | 480 | 480 | |
| | Vertical porch width | t_{VB} | 15 | 45 | 110 | |
| Data | Set up time | t_{SD} | 8 | - | - | ns |
| | Hold time | t_{HD} | 8 | - | - | |
| | Rise / Fall time | t_{Dr}, t_{Df} | - | - | 12 | ns |

9.5 TIMING CHART

DTMG (Data Enable) is the signal to determine valid data, and the timing of DTMG can be determined from Hsync and Vsync as below. For this display, only DTMG and DCLK are the essential signals. Hsync and Vsync are not necessary to connect to display interface after DTMG has been generated and input.

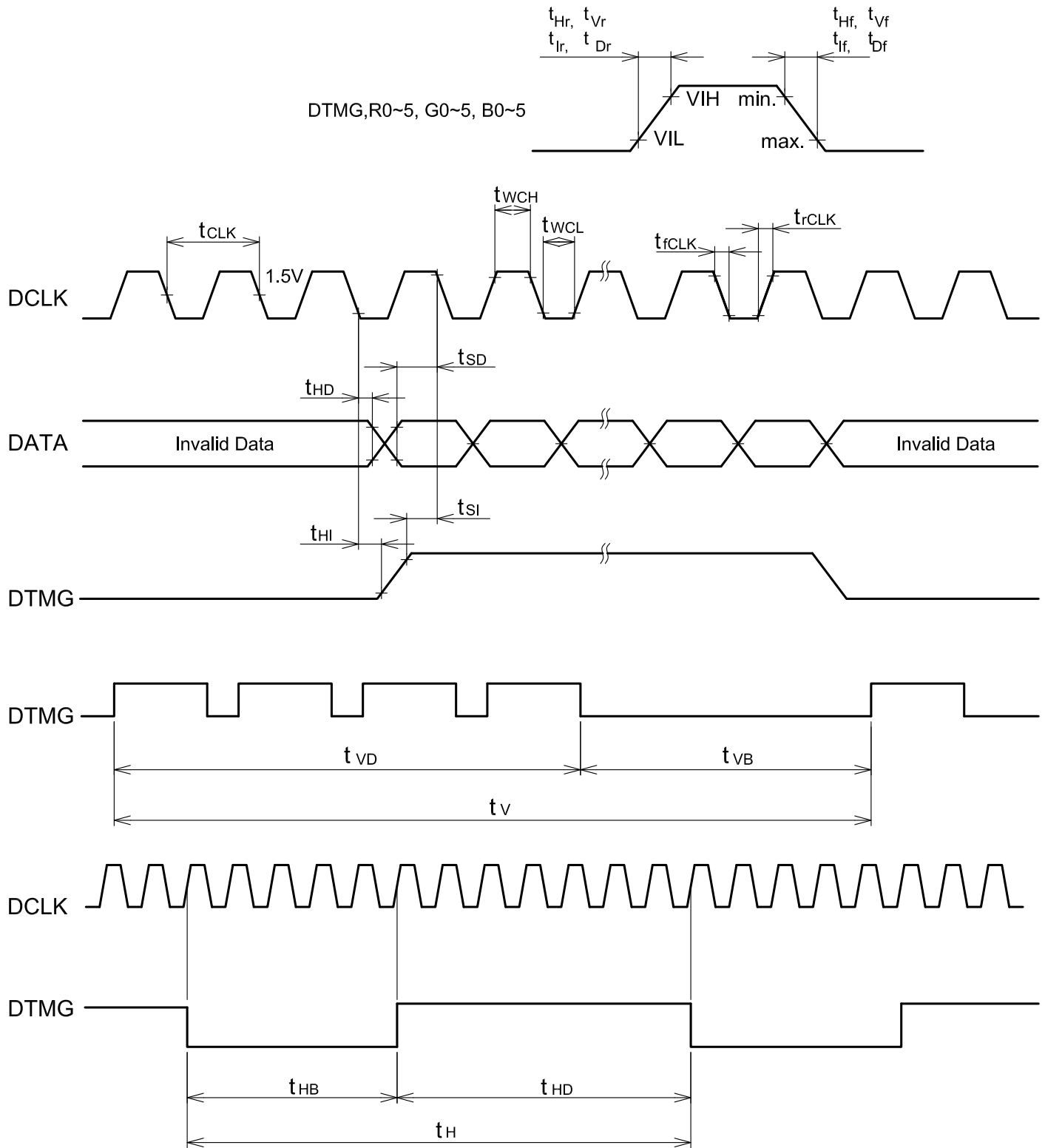

Data is latched by DCLK'S falling edge

9.6 LVDS RECEIVER TIMING

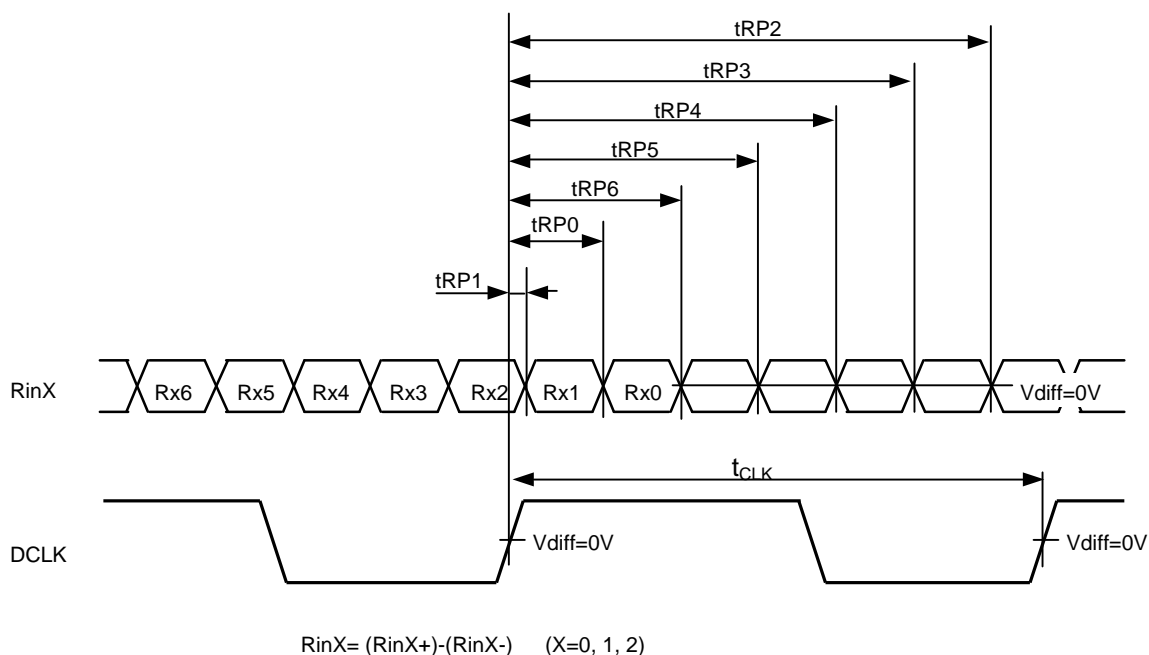

| Item | Symbol | Min. | Typ. | Max. | Unit | |
|-------------------|-------------------|-------------|------------------------|-----------------|------------------------|-----|
| DCLK | Frequency | $1/t_{CLK}$ | 22.29 | 25.2 | 34.2 | MHz |
| RinX (X=0,1,2) | 0 data position | tRP0 | $1/7 * t_{CLK} - 0.49$ | $1/7 * t_{CLK}$ | $1/7 * t_{CLK} + 0.49$ | ns |
| | 1st data position | tRP1 | -0.49 | 0 | +0.49 | |
| | 2nd data position | tRP2 | $6/7 * t_{CLK} - 0.49$ | $6/7 * t_{CLK}$ | $6/7 * t_{CLK} + 0.49$ | |
| | 3rd data position | tRP3 | $5/7 * t_{CLK} - 0.49$ | $5/7 * t_{CLK}$ | $5/7 * t_{CLK} + 0.49$ | |
| | 4th data position | tRP4 | $4/7 * t_{CLK} - 0.49$ | $4/7 * t_{CLK}$ | $4/7 * t_{CLK} + 0.49$ | |
| | 5th data position | tRP5 | $3/7 * t_{CLK} - 0.49$ | $3/7 * t_{CLK}$ | $3/7 * t_{CLK} + 0.49$ | |
| | 6th data position | tRP6 | $2/7 * t_{CLK} - 0.49$ | $2/7 * t_{CLK}$ | $2/7 * t_{CLK} + 0.49$ | |

9.7 DATA INPUT for DISPLAY COLOR

| | COLOR & Gray Scale | Data Signal | | | | | | | | | | | | | | | | | |
|-------------|--------------------|-------------|----|----|----|----|----|----|----|----|----|----|----|----|----|----|----|----|----|
| | | R5 | R4 | R3 | R2 | R1 | R0 | G5 | G4 | G3 | G2 | G1 | G0 | B5 | B4 | B3 | B2 | B1 | B0 |
| Basic Color | Black | 0 | 0 | 0 | 0 | 0 | 0 | 0 | 0 | 0 | 0 | 0 | 0 | 0 | 0 | 0 | 0 | 0 | 0 |
| | Red (0) | 1 | 1 | 1 | 1 | 1 | 1 | 0 | 0 | 0 | 0 | 0 | 0 | 0 | 0 | 0 | 0 | 0 | 0 |
| | Green (0) | 0 | 0 | 0 | 0 | 0 | 0 | 1 | 1 | 1 | 1 | 1 | 1 | 0 | 0 | 0 | 0 | 0 | 0 |
| | Blue (0) | 0 | 0 | 0 | 0 | 0 | 0 | 0 | 0 | 0 | 0 | 0 | 0 | 1 | 1 | 1 | 1 | 1 | 1 |
| | Cyan | 0 | 0 | 0 | 0 | 0 | 0 | 1 | 1 | 1 | 1 | 1 | 1 | 1 | 1 | 1 | 1 | 1 | 1 |
| | Magenta | 1 | 1 | 1 | 1 | 1 | 1 | 0 | 0 | 0 | 0 | 0 | 0 | 1 | 1 | 1 | 1 | 1 | 1 |
| | Yellow | 1 | 1 | 1 | 1 | 1 | 1 | 1 | 1 | 1 | 1 | 1 | 1 | 0 | 0 | 0 | 0 | 0 | 0 |
| | White | 1 | 1 | 1 | 1 | 1 | 1 | 1 | 1 | 1 | 1 | 1 | 1 | 1 | 1 | 1 | 1 | 1 | 1 |
| Red | Black | 0 | 0 | 0 | 0 | 0 | 0 | 0 | 0 | 0 | 0 | 0 | 0 | 0 | 0 | 0 | 0 | 0 | 0 |
| | Red (62) | 0 | 0 | 0 | 0 | 0 | 1 | 0 | 0 | 0 | 0 | 0 | 0 | 0 | 0 | 0 | 0 | 0 | 0 |
| | Red (61) | 0 | 0 | 0 | 0 | 1 | 0 | 0 | 0 | 0 | 0 | 0 | 0 | 0 | 0 | 0 | 0 | 0 | 0 |
| | : | : | : | : | : | : | : | : | : | : | : | : | : | : | : | : | : | : | : |
| | : | : | : | : | : | : | : | : | : | : | : | : | : | : | : | : | : | : | : |
| | Red (1) | 1 | 1 | 1 | 1 | 1 | 0 | 0 | 0 | 0 | 0 | 0 | 0 | 0 | 0 | 0 | 0 | 0 | 0 |
| Red (0) | 1 | 1 | 1 | 1 | 1 | 1 | 0 | 0 | 0 | 0 | 0 | 0 | 0 | 0 | 0 | 0 | 0 | 0 | |
| Green | Black | 0 | 0 | 0 | 0 | 0 | 0 | 0 | 0 | 0 | 0 | 0 | 0 | 0 | 0 | 0 | 0 | 0 | 0 |
| | Green (62) | 0 | 0 | 0 | 0 | 0 | 0 | 0 | 0 | 0 | 0 | 0 | 1 | 0 | 0 | 0 | 0 | 0 | 0 |
| | Green (61) | 0 | 0 | 0 | 0 | 0 | 0 | 0 | 0 | 0 | 0 | 0 | 1 | 0 | 0 | 0 | 0 | 0 | 0 |
| | : | : | : | : | : | : | : | : | : | : | : | : | : | : | : | : | : | : | : |
| | : | : | : | : | : | : | : | : | : | : | : | : | : | : | : | : | : | : | : |
| | Green (1) | 0 | 0 | 0 | 0 | 0 | 0 | 1 | 1 | 1 | 1 | 1 | 0 | 0 | 0 | 0 | 0 | 0 | 0 |
| Green (0) | 0 | 0 | 0 | 0 | 0 | 0 | 1 | 1 | 1 | 1 | 1 | 1 | 0 | 0 | 0 | 0 | 0 | 0 | |
| Blue | Black | 0 | 0 | 0 | 0 | 0 | 0 | 0 | 0 | 0 | 0 | 0 | 0 | 0 | 0 | 0 | 0 | 0 | 0 |
| | Blue (62) | 0 | 0 | 0 | 0 | 0 | 0 | 0 | 0 | 0 | 0 | 0 | 0 | 0 | 0 | 0 | 0 | 0 | 1 |
| | Blue (61) | 0 | 0 | 0 | 0 | 0 | 0 | 0 | 0 | 0 | 0 | 0 | 0 | 0 | 0 | 0 | 0 | 1 | 0 |
| | : | : | : | : | : | : | : | : | : | : | : | : | : | : | : | : | : | : | : |
| | : | : | : | : | : | : | : | : | : | : | : | : | : | : | : | : | : | : | : |
| | Blue (1) | 0 | 0 | 0 | 0 | 0 | 0 | 0 | 0 | 0 | 0 | 0 | 0 | 1 | 1 | 1 | 1 | 1 | 0 |
| Blue (0) | 0 | 0 | 0 | 0 | 0 | 0 | 0 | 0 | 0 | 0 | 0 | 0 | 1 | 1 | 1 | 1 | 1 | 1 | |

9.8 POWER SEQUENCE

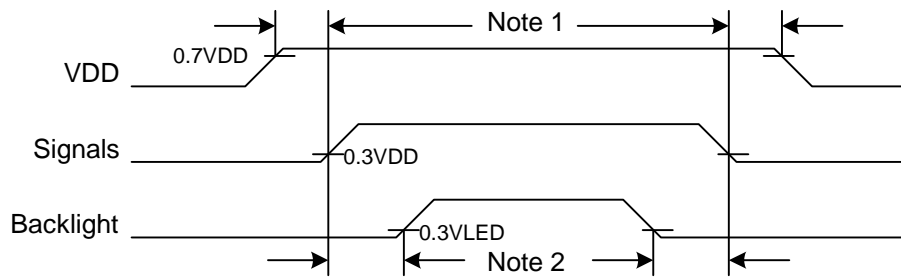

Power Sequence Timing

Note 1: In order to avoid any damages, VDD has to be applied before all other signals. The opposite is true for power off where VDD has to be remained on until all other signals have been switch off. The recommended time period is 1 second. Hot plugging might cause display damage due to incorrect power sequence, please pay attention on interface connecting before power on.

Note 2: In order to avoid showing uncompleted patterns in transient state. It is recommended that switching the backlight on is delayed for 1 second after the signals have been applied. The opposite is true for power off where the backlight has to be switched off 1 second before the signals are removed.

10. OUTLINE DIMENSIONS

10.1 FRONT VIEW

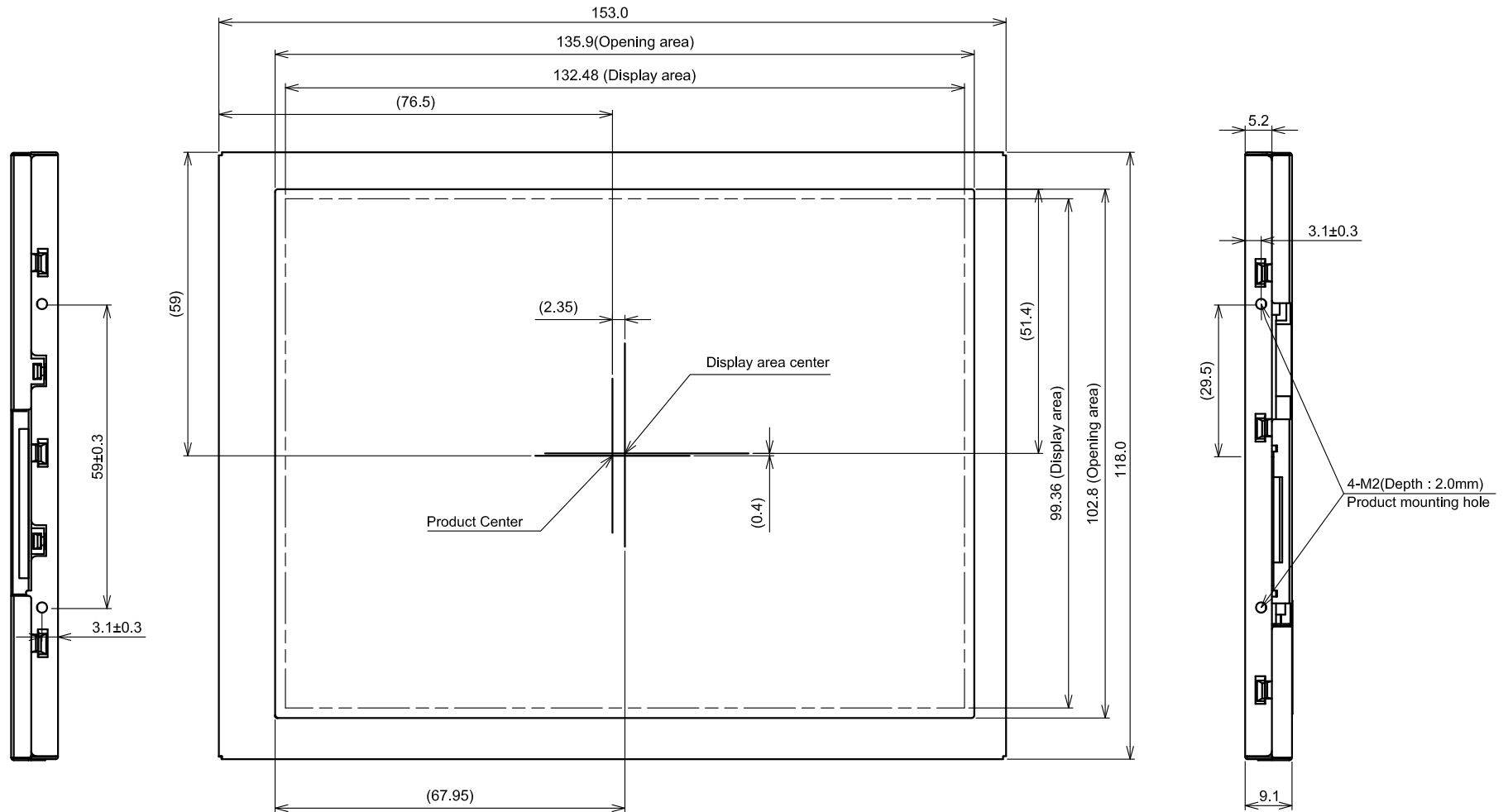

Note 1: General tolerance ±0.5

Scale : NTS
Unit : mm

10.2 REAR VIEW

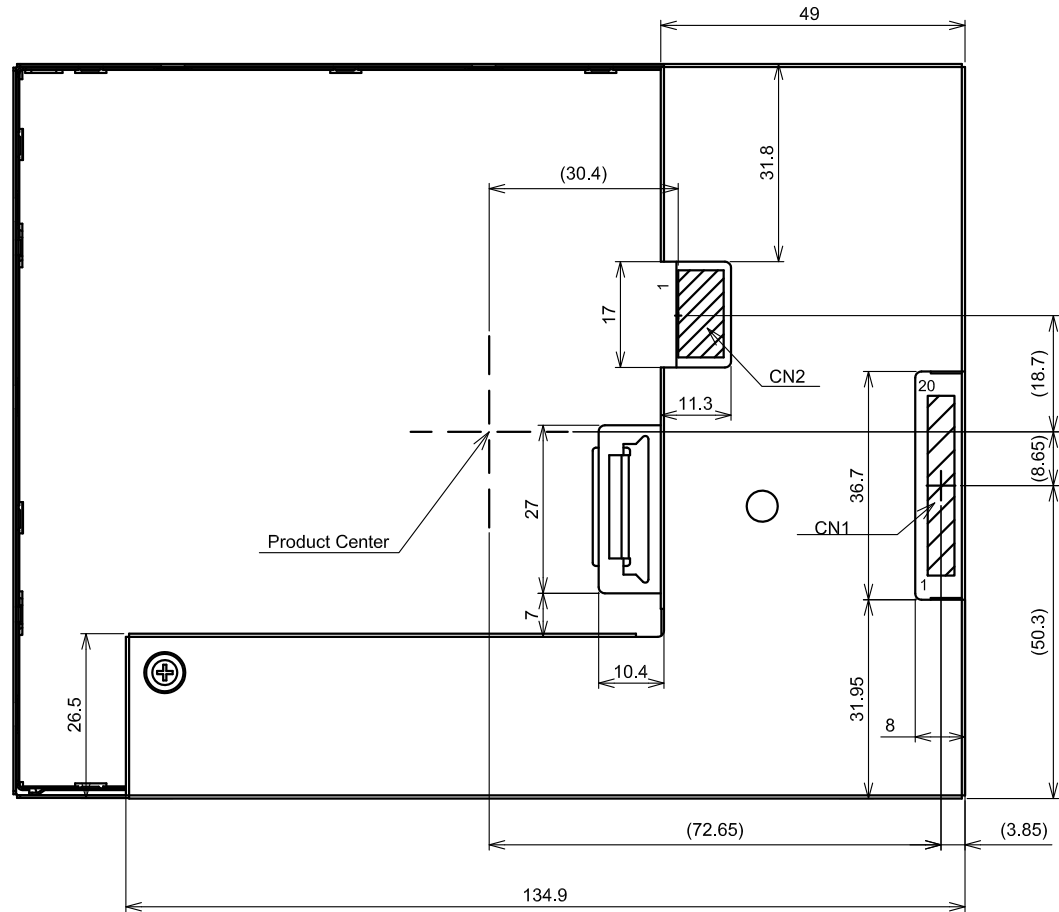

Note 1: General tolerance ± 0.5

Scale : NTS
Unit : mm

11. APPEARANCE STANDARD

The appearance inspection is performed in a dark room around 500~1000 lx based on the conditions as below:

- The distance between inspector's eyes and display is 30 cm.
- The viewing zone is defined with angle θ shown in Fig. 11. The inspection should be performed within 45° when display is shut down. The inspection should be performed within 5° when display is power on.

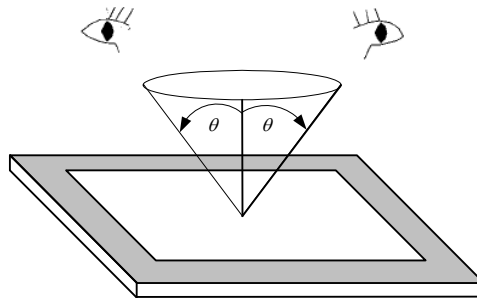

Fig. 11.1

11.1 THE DEFINITION OF LCD ZONE

LCD panel is divided into 3 areas as shown in Fig.11.2 for appearance specification in next section. A zone is the LCD active area (dot area); B zone is the area, which extended 1 mm out from LCD active area; C zone is the area between B zone and metal frame.

In terms of housing design, B zone is the recommended window area customers' housing should be located in.

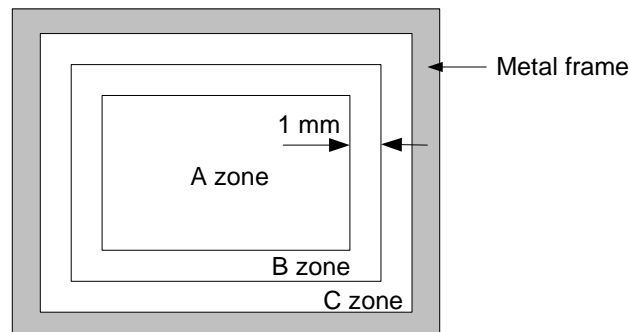

Fig. 11.2

11.2 LCD APPEARANCE SPECIFICATION

The specification as below is defined as the amount of unexpected phenomenon or material in different zones of LCD panel. The definitions of length, width and average diameter using in the table are shown in Fig. 11.3 and Fig. 11.4.

| Item | Criteria | | | | Applied zone |
|---|---------------------------------------|-------------------------|----------------------|---------------|----------------|
| Scratches | Length (mm) | Width (mm) | Maximum number | Minimum space | A |
| | Ignored | $W \leq 0.01$ | Ignored | - | |
| | $L \leq 40$ | $W \leq 0.02$ | 10 | - | |
| | $L \leq 20$ | $W \leq 0.04$ | 10 | - | |
| | Round (Dot Shape) | | | | |
| | Average diameter (mm) | Maximum number | Minimum space | | |
| | $D \leq 0.2$ | Ignore | - | | |
| | $D \leq 0.4$ | 10 | - | | |
| Dent | Serious one is not allowed | | | | A |
| Wrinkles in polarizer | Serious one is not allowed | | | | A |
| Bubbles on polarizer | Average diameter (mm) | | Maximum number | | A |
| | $D \leq 0.3$ | | Ignored | | |
| | $D \leq 0.5$ | | 10 | | |
| | $D \leq 1.0$ | | 5 | | |
| 1) Stains 2) Foreign Materials 3) Dark Spot | Filamentous (Line shape) | | | | A |
| | Length (mm) | Width (mm) | Maximum number | | |
| | Ignored | $W \leq 0.02$ | Ignored | | |
| | $L \leq 2.0$ | $W \leq 0.03$ | 10 | | |
| | $L \leq 1.0$ | $W \leq 0.06$ | 10 | | |
| | Round (Dot shape) | | | | A |
| | Average diameter (mm) | Maximum number | Minimum Space | | |
| | $D \leq 0.22$ | Ignored | - | | |
| | $D \leq 0.33$ | 5 | - | | |
| | $D > 0.33$ | 0 | - | | |
| | In total | Filamentous + Round=10 | | | |
| | Those wiped out easily are acceptable | | | | |
| | Dot-Defect (Note 1) | | | Type | Maximum number |
| Bright dot-defect | | 1 dot | 4 | | |
| | | 2 adjacent dot | 1 | | |
| | | 3 adjacent dot or above | Not allowed | | |
| | | Density | $2/\phi 20\text{mm}$ | | |
| | | In total | 5 | | |
| Dark dot-defect | | 1 dot | 5 | | |
| | | 2 adjacent dot | 2 | | |
| | | 3 adjacent dot or above | Not allowed | | |
| | | Density | $3/\phi 20\text{mm}$ | | |
| | | In total | 5 | | |
| In total | | 10 | | | |

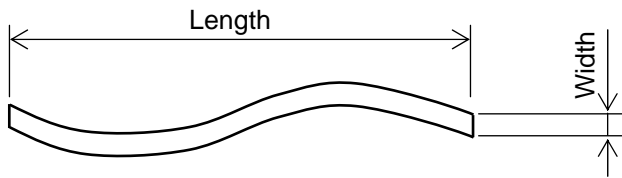

Fig 11.3

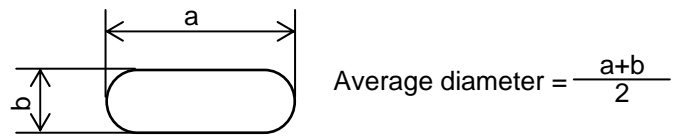

Fig 11.4

Note 1: The definitions of dot defect are as below:

- The defect area of the dot must be bigger than half of a dot.
- For bright dot-defect, showing black pattern, the dot's brightness must be over 30% brighter than others.
- For dark dot-defect, showing white pattern, the dot's brightness must be under 70% darker than others.
- The definition of 1-dot-defect is the defect-dot, which is isolated and no adjacent defect-dot.
- The definition of adjacent dot is shown as Fig. 11.5.
- The Density of dot defect is defined in the area within diameter $\phi = 20\text{mm}$.

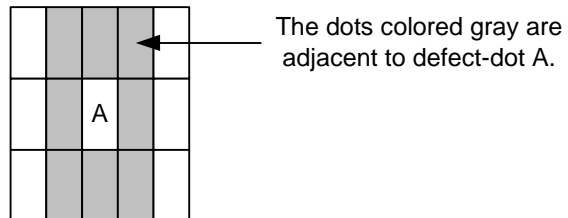

Fig. 11.5

12. PRECAUTIONS

12.1 PRECAUTIONS of ESD

- 1) Before handling the display, please ensure your body has been connected to ground to avoid any damages by ESD. Also, do not touch display's interface directly when assembling.
- 1) Please remove the protection film very slowly before turning on the display to avoid generating ESD.

12.2 PRECAUTIONS of HANDLING

- 1) In order to keep the appearance of display in good condition; please do not rub any surfaces of the displays by sharp tools harder than 3H, especially touch panel, metal frame and polarizer.
- 2) Please do not pile the displays in order to avoid any scars leaving on the display. In order to avoid any injuries, please pay more attention for the edges of glasses and metal frame, and wear finger cots to protect yourself and the display before working on it.
- 2) Touching the display area or the terminal pins with bare hand is prohibited. This is because it will stain the display area and cause poor insulation between terminal pins, and might affect display's electrical characteristics furthermore.
- 3) Do not use any harmful chemicals such as acetone, toluene, and isopropyl alcohol to clean display's surfaces.
- 4) Please use soft cloth or absorbent cotton with ethanol to clean the display by gently wiping. Moreover, when wiping the display, please wipe it by horizontal or vertical direction instead of circling to prevent leaving scars on the display's surface, especially polarizer.
- 5) Please wipe any unknown liquids immediately such as saliva, water or dew on the display to avoid color fading or any permanently damages.
- 6) Maximum pressure to the surface of the display must be less than 1.96×10^4 Pa. If the area of adding pressure is less than 1 cm^2 , the maximum pressure must be less than 1.96N.

12.3 PRECAUTIONS OF OPERATING

- 1) Please input signals and voltages to the displays according to the values defined in the section of electrical characteristics to obtain the best performance. Any voltages over than absolute maximum rating will cause permanent damages to this display. Also, any timing of the signals out of this specification would cause unexpected performance.
- 2) When the display is operating at significant low temperature, the response time will be slower than it at 25C° . In high temperature, the color will be slightly dark and blue compared to original pattern. However, these are temperature-related phenomenon of LCD and it will not cause permanent damages to the display when used within the operating temperature.
- 3) The use of screen saver or sleep mode is recommended when static images are likely for long periods of time. This is to avoid the possibility of image sticking.
- 4) Spike noise can cause malfunction of the circuit. The recommended limitation of spike noise is no bigger than $\pm 100 \text{ mV}$.

12.4 PRECAUTIONS of STORAGE

If the displays are going to be stored for years, please be aware the following notices.

- 1) Please store the displays in a dark room to avoid any damages from sunlight and other sources of UV light.
- 2) The recommended long-term storage temperature is between 10 C° ~35 C° and 55%~75% humidity to avoid causing bubbles between polarizer and LCD glasses, and polarizer peeling from LCD glasses.
- 3) It would be better to keep the displays in the container, which is shipped from KOE, and do not unpack it.
- 4) Please do not stick any labels on the display surface for a long time, especially on the polarizer.

13. DESIGNATION of LOT MARK

1) The lot mark is showing in Fig.13.1. First 4 digits are used to represent production lot, T represented made in Taiwan, and the last 6 digits are the serial number.

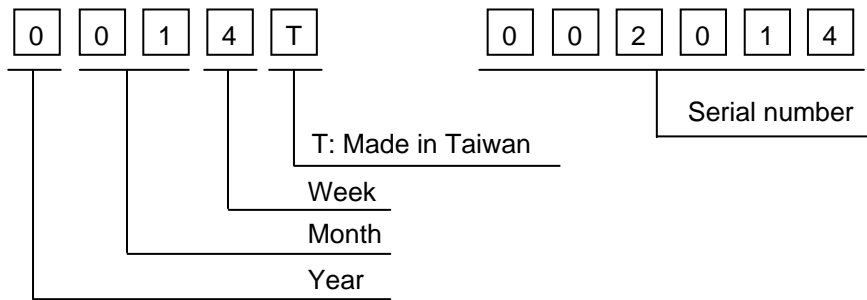

Fig. 13.1

2) The tables as below are showing what the first 4 digits of lot mark are shorted for.

| Year | Lot Mark |
|------|----------|
| 2012 | 2 |
| 2013 | 3 |
| 2014 | 4 |
| 2015 | 5 |
| 2016 | 6 |

| Month | Lot Mark | Month | Lot Mark |
|-------|----------|-------|----------|
| Jan. | 01 | Jul. | 07 |
| Feb. | 02 | Aug. | 08 |
| Mar. | 03 | Sep. | 09 |
| Apr. | 04 | Oct. | 10 |
| May | 05 | Nov. | 11 |
| Jun. | 06 | Dec. | 12 |

| Week | Lot Mark |
|------------|----------|
| 1~7 days | 1 |
| 8~14 days | 2 |
| 15~21 days | 3 |
| 22~28 days | 4 |
| 29~31 days | 5 |

3) Except letters I and O, revision number will be shown on lot mark and following letters A to Z.

| REV.No | ITEM | REMARKS |
|--------|-------------------------|----------|
| - | - | - |
| A | DC/DC converter changed | PCN 0850 |

4) The location of the lot mark is on the back of the display shown in Fig. 13.2.



Fig. 13.2