

KOE

JDI Group

Kaohsiung Opto-Electronics Inc.

FOR MESSRS : _____

DATE : May 1st, 2012

CUSTOMER'S ACCEPTANCE SPECIFICATIONS

TX16D11VM2CQC

Contents

No.	ITEM	SHEET No.	PAGE
1	COVER	7B64PS 2701-TX16D11VM2CQC-2	1-1/1
2	RECORD OF REVISION	7B64PS 2702-TX16D11VM2CQC-2	2-1/1
3	GENERAL DATA	7B64PS 2703-TX16D11VM2CQC-2	3-1/1
4	ABSOLUTE MAXIMUM RATINGS	7B64PS 2704-TX16D11VM2CQC-2	4-1/1
5	ELECTRICAL CHARACTERISTICS	7B64PS 2705-TX16D11VM2CQC-2	5-1/1
6	OPTICAL CHARACTERISTICS	7B64PS 2706-TX16D11VM2CQC-2	6-1/2~2/2
7	BLOCK DIAGRAM	7B64PS 2707-TX16D11VM2CQC-2	7-1/1
8	RELIABILITY TESTS	7B64PS 2708-TX16D11VM2CQC-2	8-1/1
9	LCD INTERFACE	7B64PS 2709-TX16D11VM2CQC-2	9-1/6~6/6
10	OUTLINE DIMENSIONS	7B64PS 2710-TX16D11VM2CQC-2	10-1/2~2/2
11	TOUCH PANEL	7B64PS 2711-TX16D11VM2CQC-2	11-1/2~2/2
12	APPEARANCE STANDARD	7B64PS 2712-TX16D11VM2CQC-2	12-1/4~4/4
13	PRECAUTIONS	7B64PS 2713-TX16D11VM2CQC-2	13-1/3~3/3
14	DESIGNATION OF LOT MARK	7B64PS 2714-TX16D11VM2CQC-2	14-1/1

ACCEPTED BY: _____

PROPOSED BY: 

2. RECORD OF REVISION

DATE	SHEET No.	SUMMARY
May 01,'12	All pages	Company name changed: KAOHSIUNG HITACHI ELECTRONICS CO.,LTD. ↓ KAOHSIUNG OPTO-ELECTRONICS INC.
	7B64PS 2704 – TX16D11VM2CQC-2 Page 4 - 1/1	4. ABSOLUTE MAXIMUM RATINGS Revised : Note2
	7B64PS 2708 – TX16D11VM2CQC-2 Page 08 - 1/1	8. RELIABILITY TESTS Added : Note4
	7B64PS 2711 – TX16D11VM2CQC-2 Page 11 - 2/2	11.5 SAFETY AND ATTENTIONS Added : Item 4)

3. GENERAL DATA

3.1 DISPLAY FEATURES

This module is a 6.2" HVGA of 8:3 format amorphous silicon TFT. The pixel format is vertical stripe and sub pixels are arranged as R(red), G(green), B(blue) sequentially. This display is RoHS compliant, and COG (chip on glass) technology and LED backlight are applied on this display.

Part Name	TX16D11VM2CQC
Module Dimensions	173.0(W) mm x 70.0(H) mm x (8.6)max (D) mm
LCD Active Area	148.8(W) mm x 53.76(H) mm
Dot Pitch	0.0775(W) mm x 3(R, G, B)(W) x 0.224(H) mm
Resolution	640 x 3(RGB)(W) x 240(H) dots
Color Pixel Arrangement	R, G, B Vertical stripe
LCD Type	Transmissive Color TFT; Normally White
Display Type	Active Matrix
Number of Colors	262k Colors
Backlight	7 LEDs parallel x 3 serial (21 LEDs in total)
Weight	(140) g (typ.)
Interface	C-MOS; 18-bit RGB; 40 pins
Power Supply Voltage	3.3V for LCD; 12V for Backlight
Power Consumption	310.2 mW for LCD (HVGA) / 363 mW for LCD (VGA) ; 1.008W for backlight
Viewing Direction	12 O'clock (The direction without image inversion and least brightness change)
Touch Panel	Resistive type; Film on Glass; 4-wire type; Ant-iglare surface

4. ABSOLUTE MAXIMUM RATINGS

Item	Symbol	Min.	Max.	Unit	Remarks	
Supply Voltage	VDD	-0.3	4.0	V	-	
Input Voltage of Logic	VI	-0.2	VDD+0.3	V	Note 1	
Operating Temperature	Top	-20	70	°C	Note 2	
Storage Temperature	Tst	-20	70	°C	Note 2	
LED Unit	Forward Current	IF	-	35	mA	Note 3
	Reverse Voltage	VR	-	5	V	

Note 1: The rating is defined for the signal voltages of the interface such as DTMG, DCLK and RGB data bus.

Note 2: The maximum rating is defined as above based on the chamber temperature, which might be different from ambient temperature after assembling the panel into the application. Moreover, some temperature-related phenomenon as below needed to be noticed:

- Background color, contrast and response time would be different in temperatures other than 25°C.
- Operating under high temperature will shorten LED lifetime.

Note 3: Fig. 4.1 shows the maximum rating of LED forward current against temperature. The backlight unit in this display has been set to 12 mA per LED. This is within the range when operating the display between -20~70°C.

For the dimming function, reducing the LED backlight voltage 12V to the expected brightness is recommended. Alternatively, using PWM signal with 10KHz and 12V amplitude to dim by adjusting the duty ratio.

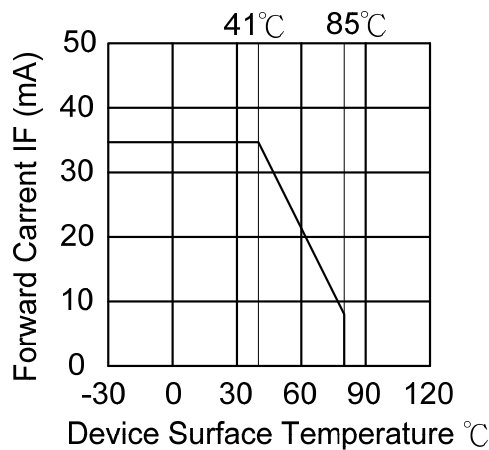

Fig. 4.1

5. ELECTRICAL CHARACTERISTICS

5.1 LCD CHARACTERISTICS

$T_a = 25\text{ }^\circ\text{C}$, $V_{SS} = 0\text{V}$

Item	Symbol	Condition	Min.	Typ.	Max.	Unit	Remarks
Power Supply Voltage	VDD	-	3.0	3.3	3.6	V	-
Input Voltage of Logic	VI	"H" level	2.0	-	VDD	V	Note 1
		"L" level	VSS	-	0.8		
Power Supply Current	IDD for HVGA	VDD-VSS =3.3V	-	94	-	mA	Note 2
	IDD for VGA		-	110	-		
Vsync Frequency	f_v	-	52	60	68	Hz	-
Hsync Frequency	f_H for HVGA	-	12.8	15.1	36.1	KHz	-
	f_H for VGA	-	25.3	29.5	36.1		
DCLK Frequency	f_{CLK} for HVGA	-	8.7	10.7	26.7	MHz	-
	f_{CLK} for VGA	-	17.2	20.9	26.7		

Note 1: The rating is defined for the signal voltages of the interface such as DTMG, DCLK and RGB data bus.

Note 2: An all black check pattern is used when measuring IDD, f_v is set to 60 Hz.

5.2 BACKLIGHT CHARACTERISTICS

$T_a = 25\text{ }^\circ\text{C}$

Item	Symbol	Condition	Min.	Typ.	Max.	Unit	Remarks
LED Input Voltage	VLED	Backlight Unit	11.5	12.0	12.5	V	Note1
LED Forward Current	ILED	Backlight Unit	-	84	95	mA	-
LED Lifetime	-	84 mA	-	40K	-	hrs	Note 2

Note 1: Fig. 5.1 shows the LED backlight circuit. The circuit has 21 LEDs in total and R is 280Ω .

Note 2: The estimated lifetime is specified as the time to reduce 50% brightness by applying 84 mA at $25\text{ }^\circ\text{C}$.

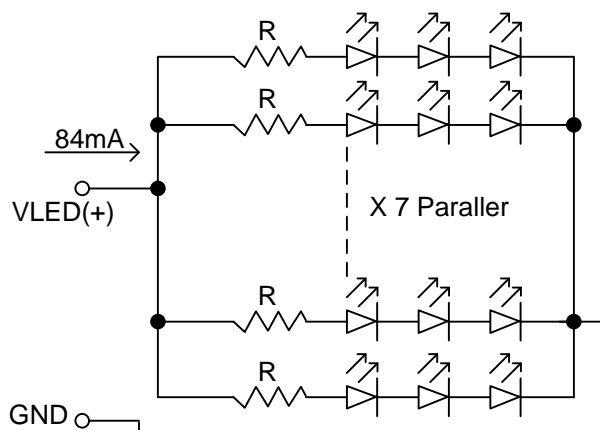

Fig. 5.1

6. OPTICAL CHARACTERISTICS

The optical characteristics are measured based on the conditions as below:

- Supplying the signals and voltages defined in the section of electrical characteristics.
- The backlight unit needs to be turned on for 30 minutes.
- The ambient temperature is 25 °C .
- In the dark room around 500~1000 lx, the equipment has been set for the measurements as shown in Fig 6.1.

$$T_a = 25\text{ }^{\circ}\text{C}, f_v = 60\text{ Hz}, VDD = 3.3\text{V}$$

Item	Symbol	Condition	Min.	Typ.	Max.	Unit	Remarks
Brightness of White	-	$\phi = 0^{\circ}, \theta = 0^{\circ}$, ILED= 84 mA	-	280	-	cd/m ²	Note 1
Brightness Uniformity	-		75	-	-	%	Note 2
Contrast Ratio	CR		100	200	-	-	Note 3
Response Time	Rise + Fall	$\phi = 0^{\circ}, \theta = 0^{\circ}$	-	45	-	ms	Note 4
NTSC Ratio	-	$\phi = 0^{\circ}, \theta = 0^{\circ}$	-	60	-	%	-
Viewing Angle	θ_x	$\phi = 0^{\circ}, CR \geq 5$	-	70	-	Degree	Note 5
	$\theta_{x'}$	$\phi = 180^{\circ}, CR \geq 5$	-	70	-		
	θ_y	$\phi = 90^{\circ}, CR \geq 5$	-	60	-		
	$\theta_{y'}$	$\phi = 270^{\circ}, CR \geq 5$	-	70	-		
Color Chromaticity	Red	X	-	0.61	-	-	Note 6
		Y	-	0.37	-		
	Green	X	-	0.32	-		
		Y	-	0.59	-		
	Blue	X	-	0.15	-		
		Y	-	0.08	-		
	White	X	-	0.34	-		
		Y	-	0.35	-		

Note 1: The brightness is measured from 9 point average value of the panel, P5 in Fig. 6.2, for the typical value.

Note 2: The brightness uniformity is calculated by the equation as below:

$$\text{Brightness uniformity} = \frac{\text{Min. Brightness}}{\text{Max. Brightness}} \times 100\%$$

, which is based on the brightness values of the 9 points measured by BM-5 as shown in Fig. 6.2.

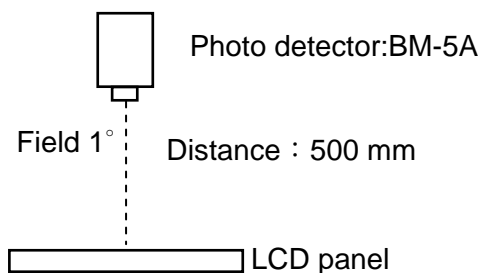

Fig. 6.1

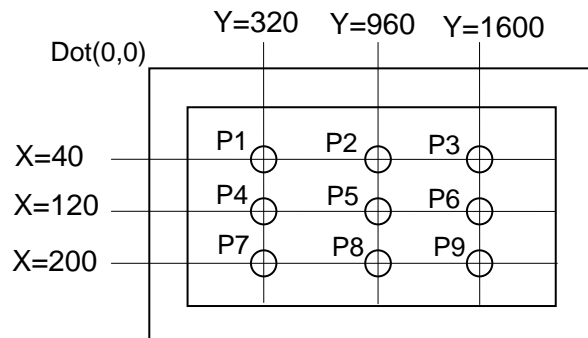

Fig. 6.2

Note 3: The Contrast ratio is measured from the center point of the panel, P5, and defined as the following equation:

$$CR = \frac{\text{Brightness of White}}{\text{Brightness of Black}}$$

Note 4: The definition of response time is shown in Fig. 6.3. The rising time is the period from 90% brightness to 10% brightness when the data is from white to black. Oppositely, Falling time is the period from 10% brightness rising to 90% brightness.

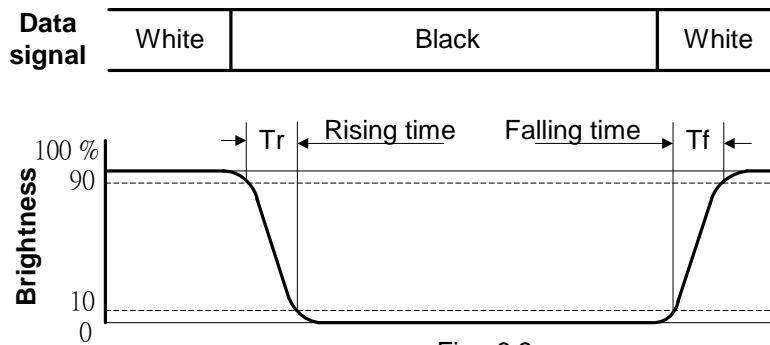

Fig . 6.3

Note 5: The definition of viewing angle is shown in Fig. 6.4. Angle ϕ is used to represent viewing directions, for instance, $\phi = 270^\circ$ means 6 o'clock, and $\phi = 0^\circ$ means 3 o'clock. Moreover, angle θ is used to represent viewing angles from axis Z toward plane XY.

The viewing direction of this display is 12 o'clock, which means that a photograph with gray scale would not be reversed in color and the brightness change would be less from this direction. However, the best contrast peak would be located at 6 o'clock.

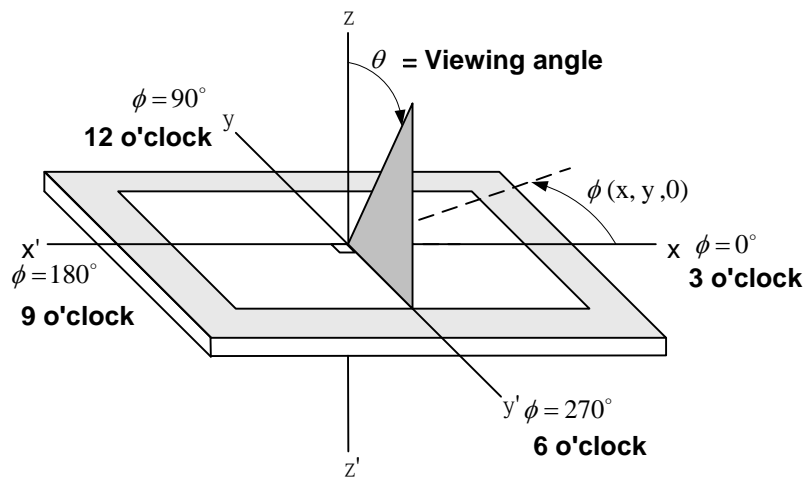
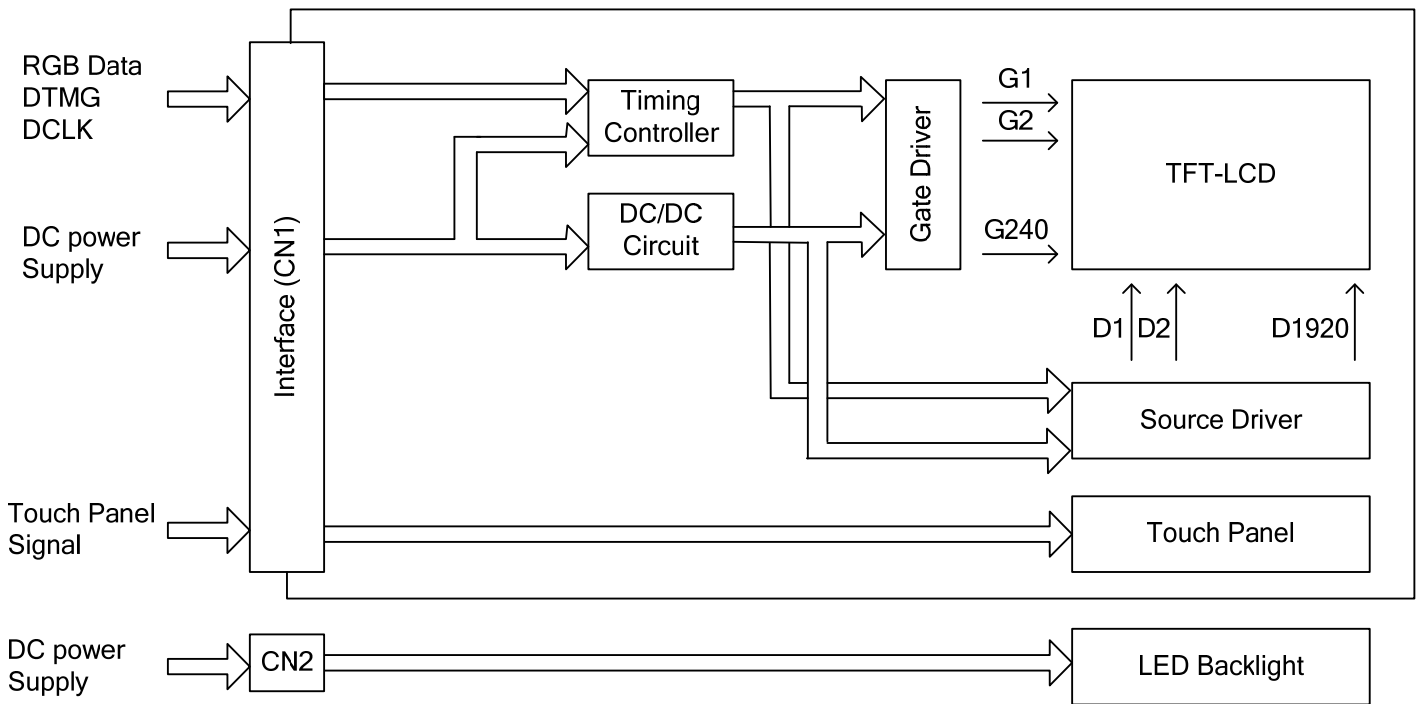

Fig. 6.4

Note 6: The color chromaticity is measured from the center point of the panel, P5, as shown in Fig. 6.2.

7. BLOCK DIAGRAM



8. RELIABILITY TESTS

Test Item	Condition	
High Temperature	1) Operating 2) 70 °C	240 hrs
Low Temperature	1) Operating 2) -20 °C	240 hrs
High Temperature	1) Storage 2) 70 °C	240 hrs
Low Temperature	1) Storage 2) -20 °C	240 hrs
Heat Cycle	1) Operating 2) -20 °C ~70 °C 3) 3hrs~1hr~3hrs	240 hrs
Thermal Shock	1) Non-Operating 2) -35 °C ↔ 85 °C 3) 0.5 hr ↔ 0.5 hr	240 hrs
High Temperature & Humidity	1) Operating 2) 40 °C & 85%RH 3) Without condensation (Note 3)	240 hrs
Vibration	1) Non-Operating 2) 20~200 Hz 3) 2G 4) X, Y, and Z directions	1 hr for each direction
Mechanical Shock	1) Non-Operating 2) 10 ms 3) 50G 4) ±X, ±Y and ±Z directions	Once for each direction
ESD	1) Operating 2) Tip: 200 pF, 250 Ω 3) Air discharge for glass: ± 8KV 4) Contact discharge for metal frame: ± 8KV	1) Glass: 9 points 2) Metal frame: 8 points (Note4)

Note 1: Display functionalities are inspected under the conditions defined in the specification after the reliability tests.

Note 2: The display is not guaranteed for use in corrosive gas environments.

Note 3: Under the condition of high temperature & humidity, if the temperature is higher than 40°C, the humidity needs to be reduced as Fig. 8.1 shown.

Note 4: All pins of LCD interface(CN1) have been tested by ±100V contact discharge of ESD under non-operating condition.

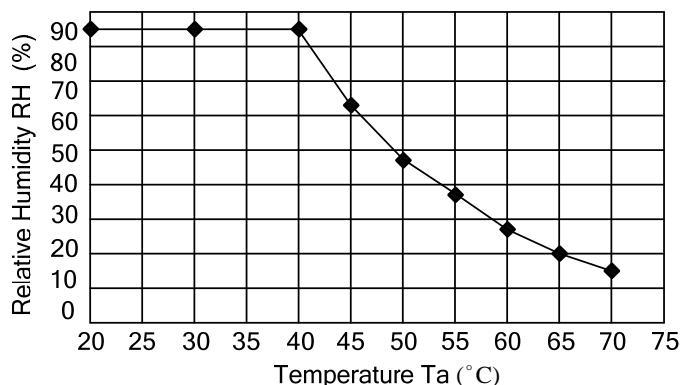

Fig. 8.1

9. LCD INTERFACE

9.1 INTERFACE PIN CONNECTIONS

The display interface connector is FA5B040HP1R3000 made by JAE (Thickness: $0.3 \pm 0.05\text{mm}$; Pitch: $0.5 \pm 0.05\text{mm}$) and more details of the connector are shown in the section of outline dimension.

Pin assignment of LCD interface is as below:

Pin No.	Signal	Function	Pin No.	Signal	Function	
1	VDD	Power Supply for Logic	21	G4	Green Data	
2	VDD		22	G3		
3	VDD		23	VSS	GND	
4	VDD		24	G2	Green Data	
5	NC	No Connection	25	G1		
6	DTMG	Timing Signal for Data	26	G0	Red Data	
7	VSS	GND	27	VSS		GND
8	DCLK	Dot Clock	28	R5		
9	VSS	GND	29	R4	Red Data	
10	NC	No Connection	30	R3		
11	VSS	GND	31	VSS	GND	
12	B5	Blue Data	32	R2	Red Data	
13	B4		33	R1		
14	B3		34	R0		
15	VSS	GND	35	Vcom	Common Voltage (Generated by LCM)	
16	B2	Blue Data	36	VSS	GND	
17	B1		37	X1	Analog Signal Touch Panel	
18	B0		38	Y1	Analog Signal Touch Panel	
19	VSS	GND	39	X2	Analog Signal Touch Panel	
20	G5	Green Data	40	Y2	Analog Signal Touch Panel	

Note 1: Keep open electrically , KOE test use only.

The backlight interface connector is BHR-03VS-1 made by JST, and pin assignment of backlight is as below:

Pin No.	Signal	Level	Function
1	V _{LED+}	-	Power Supply for LED
2	NC	-	No connection
3	V _{LED-}	-	GND

9.2 TIMING CHART

DTMG (Data Enable) is the signal to determine valid data, and the timing of DTMG can be determined from Hsync and Vsync as below. For this display, only DTMG and DCLK are the essential signals. Hsync and Vsync are not necessary to connect to display interface after DTMG has been generated and input.

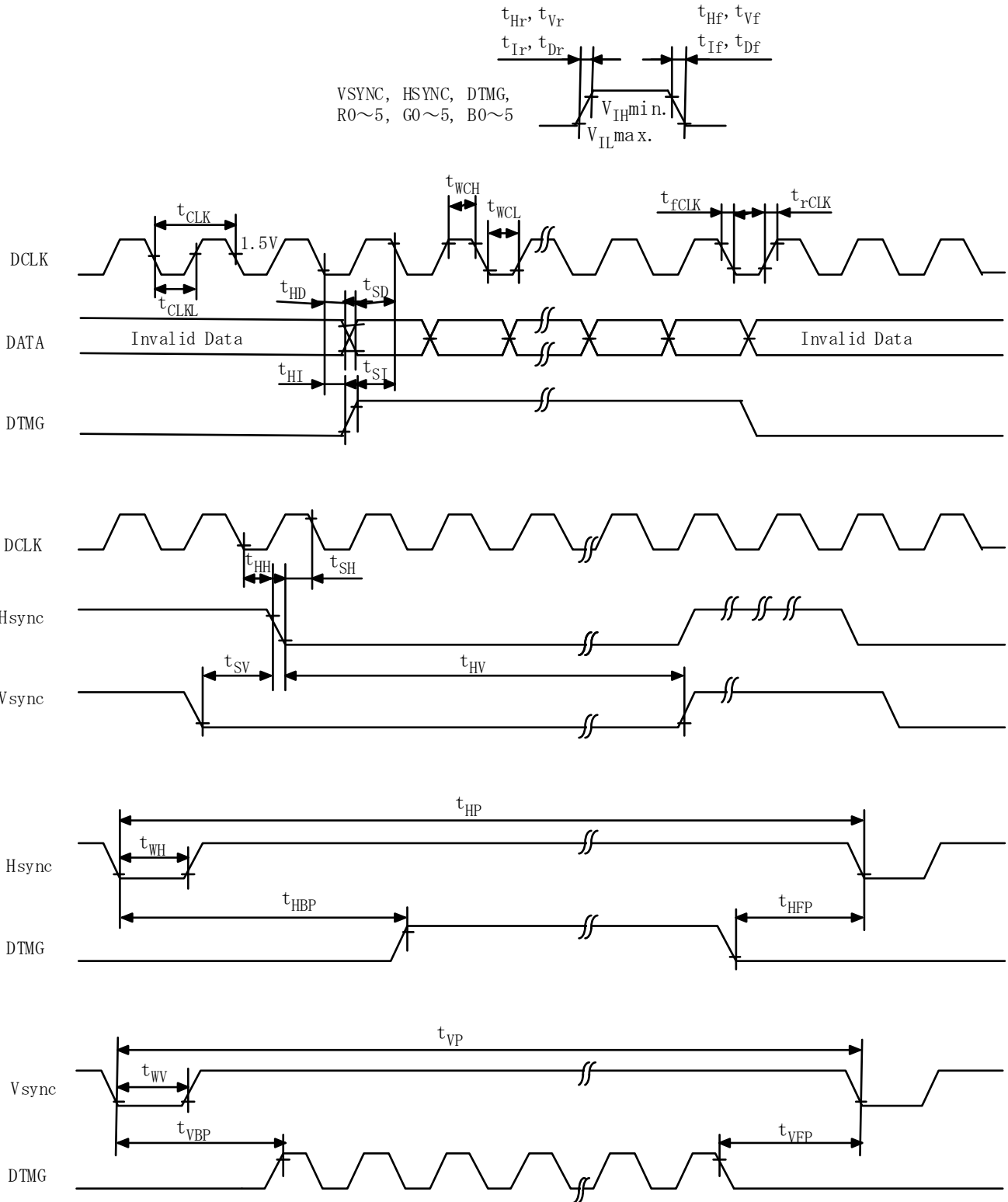

Data is latched by falling edge triggered DCLK

9.3 INTERFACE TIMING SPECIFICATIONS

9.3.1 INTERFACE TIMING FOR HVGA DISPLAY MODE

Item		Symbol	Min.	Typ.	Max.	Unit
DCLK	Cycle time	t_{CLK}	37.5	94	114.9	ns
	Low level Width	t_{WCL}	15	-	-	
	High level Width	t_{WCH}	15	-	-	
	Rise time	t_{rCLK}	-	-	25	
	Fall time	t_{fCLK}	-	-	25	
	Duty	D	0.45	0.5	0.55	-
Hsync	Set up time	t_{SH}	5	-	-	ns
	Hold time	t_{HH}	10	-	-	tCLK
	Cycle	t_{HP}	679	709	739	
	Valid width	t_{WH}	4	5	5	
	Rise/Fall time	t_{Hr}, t_{Hf}	-	-	30	ns
Vsync	Set up	t_{SV}	0	-	-	tCLK
	Hold	t_{HV}	2	-	-	tHP
	Cycle	t_{VP}	245	251	533	
	Valid width	t_{WV}	2	2	2	
	Rise/Fall time	t_{Vr}, t_{Vf}	-	-	50	ns
DTMG	Set up time	t_{SI}	5	-	-	ns
	Hold time	t_{HI}	10	-	-	tCLK
	Rise/Fall time	t_{Ir}, t_{If}	-	-	30	
	Horizontal back porch	t_{HBP}	24	37	50	
	Horizontal front porch	t_{HFP}	15	32	49	
	Vertical back porch	t_{VBP}	4	7	28	tHP
	Vertical front porch	t_{VFP}	1	4	25	
Data	Set up time	t_{SD}	5	-	-	ns
	Hold time	t_{HD}	10	-	-	ns
	Rise/Fall time	t_{Dr}, t_{Df}	-	-	25	

Note 1: Vsync needs to be set as odd numbers.

9.3.2 INTERFACE TIMING FOR VGA DISPLAY MODE

	Item	Symbol	Min.	Typ.	Max.	Unit
DCLK	Cycle time	t_{CLK}	37.4	47.8	58.1	ns
	Low level Width	t_{WCL}	15	-	-	
	High level Width	t_{WCH}	15	-	-	
	Rise time	t_{rCLK}	-	-	25	
	Fall time	t_{fCLK}	-	-	25	
	Duty	D	0.45	0.5	0.55	-
Hsync	Set up time	t_{SH}	5	-	-	ns
	Hold time	t_{HH}	10	-	-	tCLK
	Cycle	t_{HP}	679	709	739	
	Valid width	t_{WH}	4	5	5	
	Rise/Fall time	t_{Hr}, t_{Hf}	-	-	30	ns
Vsync	Set up	t_{SV}	0	-	-	tCLK
	Hold	t_{HV}	2	-	-	
	Cycle	t_{VP}	485	491	533	tHP
	Valid width	t_{WV}	2	2	2	ns
	Rise/Fall time	t_{Vr}, t_{Vf}	-	-	50	
DTMG	Set up time	t_{SI}	5	-	-	ns
	Hold time	t_{HI}	10	-	-	
	Rise/Fall time	t_{Ir}, t_{If}	-	-	30	ns
	Horizontal back porch	t_{HBP}	24	37	50	
	Horizontal front porch	t_{HFP}	15	32	49	tCLK
	Vertical back porch	t_{VBP}	4	7	28	
	Vertical front porch	t_{VFP}	1	4	25	
Data	Set up time	t_{SD}	5	-	-	ns
	Hold time	t_{HD}	10	-	-	
	Rise/Fall time	t_{Dr}, t_{Df}	-	-	25	ns

Note 1: Vsync needs to be set as odd numbers.

9.4 POWER SEQUENCE

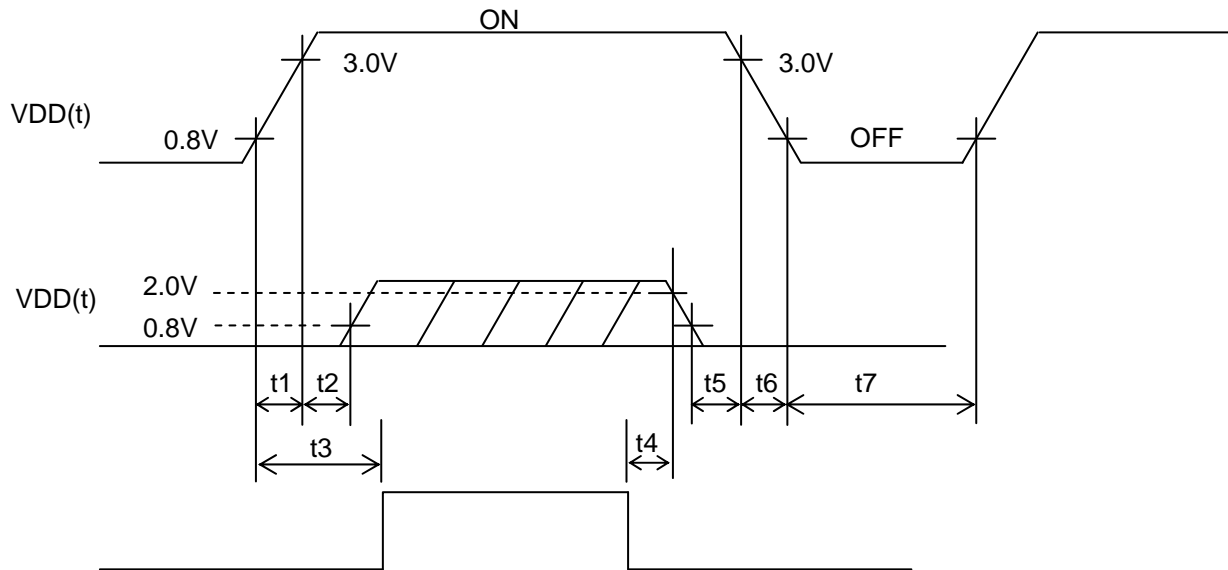

POWER ON

$$t1 \leq 15\text{ms}$$

$$0\text{ms} < t2 \leq 45\text{ms}$$

$$0.1\text{s} \leq t3$$

POWER OFF

$$5\text{ms} \leq t4$$

$$0\text{ms} < t5 \leq 45\text{ms}$$

$$0\text{ms} < t6 \leq 20\text{ms}$$

$$0.4\text{s} \leq t7$$

Note 1 : $0\text{V} \leq VI(t) \leq VDD(t)$

$VI(t)$ and $VDD(t)$ is a surfeit of condition for power on/off.

Note 2 : Input Voltage(Signal) should not be set high impedance when power on.

9.5 DATA INPUT for DISPLAY COLOR

	COLOR & Gray Scale	Data Signal																	
		R5	R4	R3	R2	R1	R0	G5	G4	G3	G2	G1	G0	B5	B4	B3	B2	B1	B0
Basic Color	Black	0	0	0	0	0	0	0	0	0	0	0	0	0	0	0	0	0	0
	Red (0)	1	1	1	1	1	1	0	0	0	0	0	0	0	0	0	0	0	0
	Green (0)	0	0	0	0	0	0	1	1	1	1	1	1	0	0	0	0	0	0
	Blue (0)	0	0	0	0	0	0	0	0	0	0	0	0	1	1	1	1	1	1
	Cyan	0	0	0	0	0	0	1	1	1	1	1	1	1	1	1	1	1	1
	Magenta	1	1	1	1	1	1	0	0	0	0	0	0	1	1	1	1	1	1
	Yellow	1	1	1	1	1	1	1	1	1	1	1	1	0	0	0	0	0	0
	White	1	1	1	1	1	1	1	1	1	1	1	1	1	1	1	1	1	1
Red	Black	0	0	0	0	0	0	0	0	0	0	0	0	0	0	0	0	0	0
	Red (62)	0	0	0	0	0	1	0	0	0	0	0	0	0	0	0	0	0	0
	Red (61)	0	0	0	0	1	0	0	0	0	0	0	0	0	0	0	0	0	0
	:	:	:	:	:	:	:	:	:	:	:	:	:	:	:	:	:	:	:
	:	:	:	:	:	:	:	:	:	:	:	:	:	:	:	:	:	:	:
	Red (1)	1	1	1	1	1	0	0	0	0	0	0	0	0	0	0	0	0	0
	Red (0)	1	1	1	1	1	1	0	0	0	0	0	0	0	0	0	0	0	0
Green	Black	0	0	0	0	0	0	0	0	0	0	0	0	0	0	0	0	0	0
	Green (62)	0	0	0	0	0	0	0	0	0	0	0	1	0	0	0	0	0	0
	Green (61)	0	0	0	0	0	0	0	0	0	0	1	0	0	0	0	0	0	0
	:	:	:	:	:	:	:	:	:	:	:	:	:	:	:	:	:	:	:
	:	:	:	:	:	:	:	:	:	:	:	:	:	:	:	:	:	:	:
	Green (1)	0	0	0	0	0	0	1	1	1	1	1	0	0	0	0	0	0	0
	Green (0)	0	0	0	0	0	0	1	1	1	1	1	1	0	0	0	0	0	0
Blue	Black	0	0	0	0	0	0	0	0	0	0	0	0	0	0	0	0	0	0
	Blue (62)	0	0	0	0	0	0	0	0	0	0	0	0	0	0	0	0	0	1
	Blue (61)	0	0	0	0	0	0	0	0	0	0	0	0	0	0	0	0	1	0
	:	:	:	:	:	:	:	:	:	:	:	:	:	:	:	:	:	:	:
	:	:	:	:	:	:	:	:	:	:	:	:	:	:	:	:	:	:	:
	Blue (1)	0	0	0	0	0	0	0	0	0	0	0	0	1	1	1	1	1	0
Blue (0)	0	0	0	0	0	0	0	0	0	0	0	0	1	1	1	1	1	1	

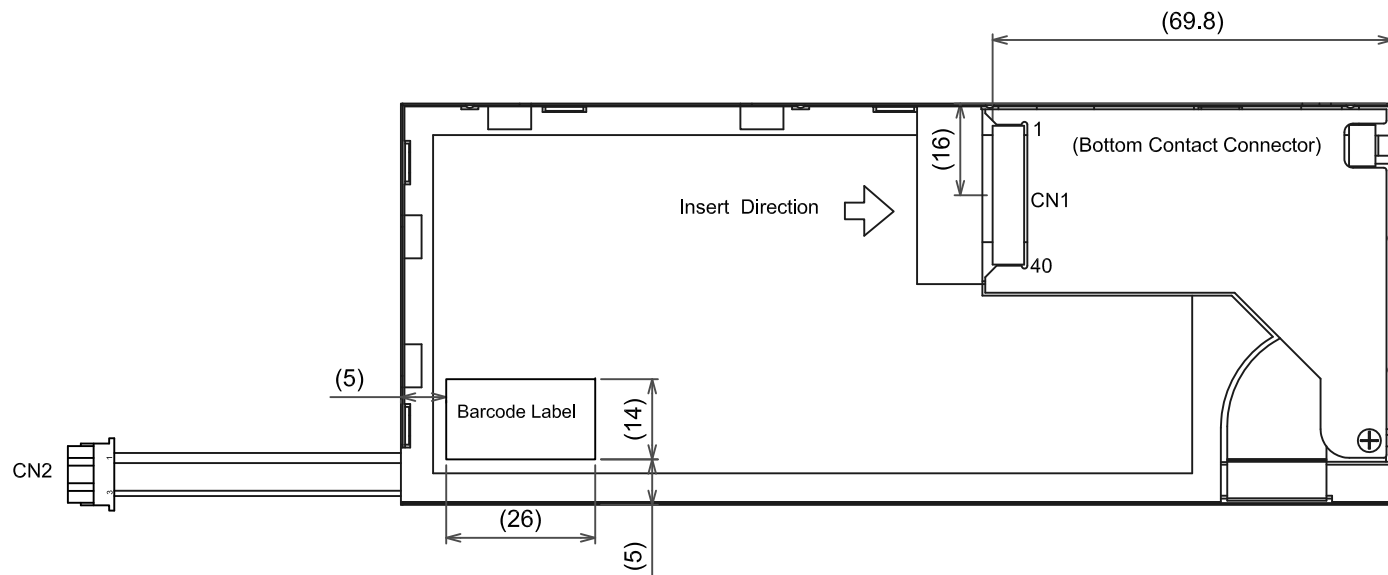

Scale : NTS
Unit : mm

11. TOUCH PANEL

The type of touch panel used on this display is resistive, analog, 4-wire and film on glass, and more characteristics are shown as below:

11.1 OPERATING CONDITIONS

Item	Specification	Remarks
Operating Voltage	5VDC	-

11.2 ELECTRICAL CHARACTERISTICS

Item	Specification	Remarks
Resistance Between Terminal	X1-X2	630~1610Ω
	Y1-Y2	110~340Ω
Insulation Resistance	X-Y	20MΩ min. At 25V DC
Linearity	X	±1.5% max.
	Y	±1.5% max.
Chattering	10ms max.	-

Note 1: The test conditions and equipments of linearity are as below:

- Material of pen: poly-acetal resin
- End shape: R 0.8 mm
- Test force: 100 g
- Pitch: 10 mm
- Test area is shown in Fig. 11.1

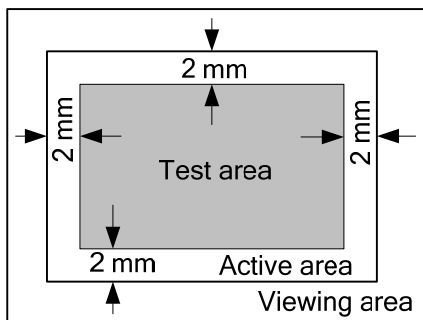

Fig. 11.1

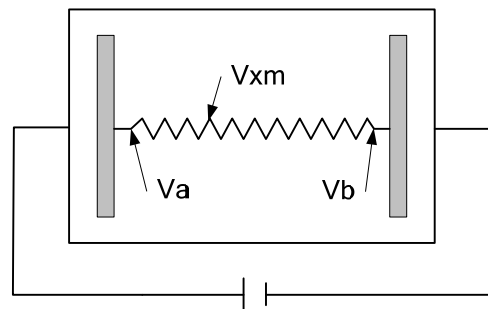

Fig. 11.2

As shown in Fig. 11.2, applying voltage meter to measure Va, Vb and Vxm, where Va is the maximum voltage in the active area; Vb is the minimum voltage in the active area; Vxm is the measured voltage of point x selected by random. Afterwards, the linearity can be calculated by following equation:

$$Linearity = \frac{|V_{xi} - V_{xm}|}{V_a - V_b} \times 100\%$$

where Vxi is the idea voltage of point x.

The method to measure the linearity of Y-axis is the same as above.

11.3 MECHANICAL CHARACTERISTICS

Item	Specification	Remarks
Pen Input Pressure	1.2N max.	R0.8, Polyacetal Pen
Finger	1.2N max.	R8.0, Silicon Rubber
Surface Hardness	3H min.	JIS K 5400

11.4 OPTICAL CHARACTERISTICS

Item	Specification	Remarks
Transmittance	80% min.	-

11.5 SAFETY AND ATTENTIONS

- 1) Do not put heavy shock or stress on the touch panel.
- 2) Please use soft cloth or absorbent cotton with ethanol to clean the touch panel by gently wiping. Moreover, please wipe it by horizontal or vertical direction instead of circling to prevent leaving scars on the touch panel's surface.
- 3) Do not use any harmful chemicals such as acetone, toluene, and isopropyl alcohol to clean the display's surface.
- 4) UV protection is recommended to avoid the possibility of performance degrading when touch panel is likely applied under UV environment for a long period of time.

12. APPEARANCE STANDARD

The appearance inspection is performed in a dark room around 2000 lx based on the conditions as below:

- The distance between inspector's eyes and display is 30 cm.
- The viewing zone is defined with angle θ shown in Fig. 12.1 The inspection should be performed within 45° when display is shut down. The inspection should be performed within 5° when display is power on.

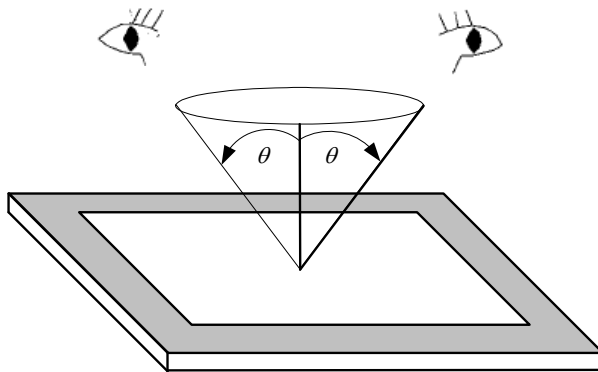

Fig. 12.1

12.1 THE DEFINITION OF LCD ZONE

LCD panel is divided into 3 areas as shown in Fig.12.2 for appearance specification in next section. A zone is the LCD active area (dot area); B zone is the area, which extended 1 mm out from LCD active area; C zone is the area between B zone and metal frame.

In terms of housing design, B zone is the recommended window area customers' housing should be located in.

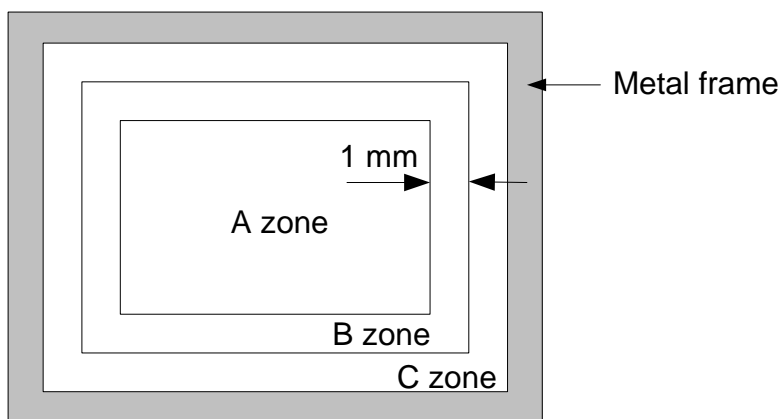

Fig. 12.2

12.2 LCD APPEARANCE SPECIFICATION

The specification as below is defined as the amount of unexpected phenomenon or material in different zones of LCD panel. The definitions of length, width and average diameter using in the table are shown in Fig. 12.3 and Fig. 12.4.

Item	Criteria				Applied zone
Scratches	Length (mm)	Width (mm)	Maximum number	Minimum space	A,B
	Ignored	$W \leq 0.02$	Ignored	-	
	$L \leq 40$	$0.02 < W \leq 0.04$	10	-	
	$L \leq 20$	$W \leq 0.04$	10	-	
Dent	Serious one is not allowed				A
Wrinkles in polarizer	Serious one is not allowed				A
Bubbles on polarizer	Average diameter (mm)		Maximum number		A
	$D \leq 0.2$		Ignored		
	$0.2 < D \leq 0.3$		12		
	$0.3 < D \leq 0.5$		3		
	$0.5 < D$		none		
1) Stains 2) Foreign Materials 3) Dark Spot	Filamentous (Line shape)				A,B
	Length (mm)	Width (mm)	Maximum number		
	$L \leq 2.0$	$W \leq 0.03$	Ignored		
	$L \leq 3.0$	$0.03 < W \leq 0.05$	6		
	$L \leq 2.5$	$0.05 < W \leq 0.1$	1		
	Round (Dot shape)				A,B
	Average diameter (mm)	Maximum number	Minimum Space		
	$D \leq 0.2$	Ignored	-		
	$0.2 \leq D < 0.3$	10	10 mm		
	$0.3 \leq D < 0.4$	5	30 mm		
	$0.4 \leq D$	none	-		
	In total	Filamentous + Round=10			
	Those wiped out easily are acceptable				
	Dot-Defect (Note 1)		Type	Maximum number	
Bright dot-defect		1 dot	4		
		2 dot	1		
		In total	5		
Dark dot-defect		1 dot	5		
		2 dot	2		
		In total	5		
In total			10		

(2) CFL BACKLIGHT APPEARANCE

Item	Criteria			Applied zone
Dark Spots White Spots Foreign Materials(Spot)	Average diameter (mm)	Maximum number		A
	$D \leq 0.4$	ignored		
	$0.4 < D$	none		
Foreign Materials (Line)	Width (mm)	Length (mm)	Maximum number	A
	$W \leq 0.2$	$L \leq 2.5$	1	
		$2.5 < L$	None	
$0.2 < W$	-	none		
Scratches	Width (mm)	Length (mm)	Maximum number	A
	$W \leq 0.1$	-	ignored	
	$0.1 < W \leq 0.2$	$L \leq 11.0$	1	
		$11.0 < L$	None	
$0.2 < W$	-	none		

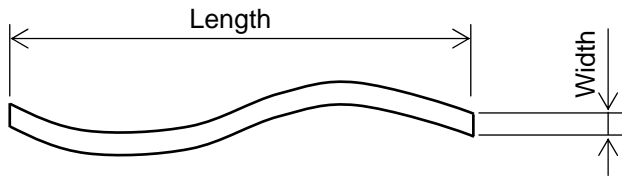

Fig 12.3

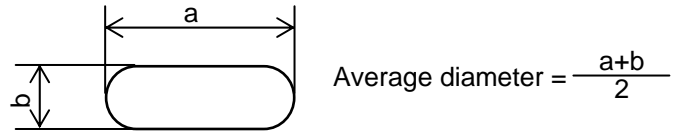
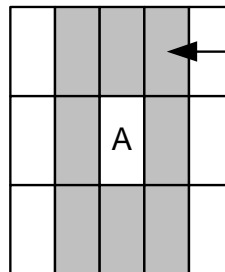

Fig 12.4

Note 1: The definitions of dot defect are as below:

- The defect area of the dot must be bigger than half of a dot.
- For bright dot-defect, showing black pattern, the dot's brightness must be over 30% brighter than others.
- For dark dot-defect, showing white pattern, the dot's brightness must be under 70% darker than others.
- The definition of 1-dot-defect is the defect-dot, which is isolated and no adjacent defect-dot.
- The definition of adjacent dot is shown as Fig. 12.5.
- The Density of dot defect is defined in the area within diameter $\phi = 20\text{mm}$.



The dots colored gray are adjacent to defect-dot A.

Fig. 12.5

12.3 TOUCH PANEL APPEARANCE SPECIFICATION

The specification as below is defined by the amount of unexpected material in different zones of touch panel.

Item	Criteria			Applied zone
Scratches	Width (mm)	Length (mm)	Maximum number	A
	$W > 0.1$	-	Not allowed	
	$0.10 \geq W > 0.05$	$10 < L$	4 pcs max.	
	$0.05 \geq W$	-	Ignored	
Foreign Materials	Filamentous (Line shape)			A
	Width (mm)	Length (mm)	Maximum number	
	$W > 0.10$	-		
	$0.10 \geq W > 0.05$	$3 < L$	Not allowed	
	$0.05 \geq W$	-	Ignored	
	Round (Dot shape)			A
	Average diameter (mm)		Maximum number	
	$D > 0.3$		Not allowed	
$0.3 \geq D > 0.25$		3 pcs max.		
$0.25 > D$		Ignored		

The limitation of glass flaw occurred on touch panel is defined in the table as below.

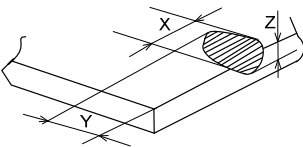
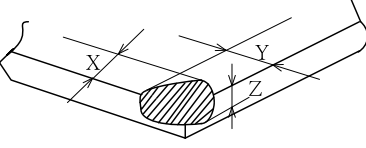
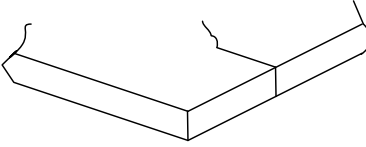
Item	Specifications	
Edge flaw		$X \leq 5.0 \text{ mm}$ $Y \leq 1.0 \text{ mm}$ $Z \leq \text{Thickness}$
Corner flaw		$X \leq 3.0 \text{ mm}$ $Y \leq 3.0 \text{ mm}$ $Z \leq \text{Thickness}$
Progressive flaw		Not allowed

13. PRECAUTIONS

13.1 PRECAUTIONS of MOUNTING

1) Please refer to Fig. 13.1 for housing the display with touch panel into applications. The Fig. 13.1 shows some points as below:

- The cushion needs to be designed between housing and touch panel in order to avoid unexpected pressure to cause any wrong reactions, and the cushion should be located in the insulated area.
- The housing should not cover the active area of touch panel as the figure shown.

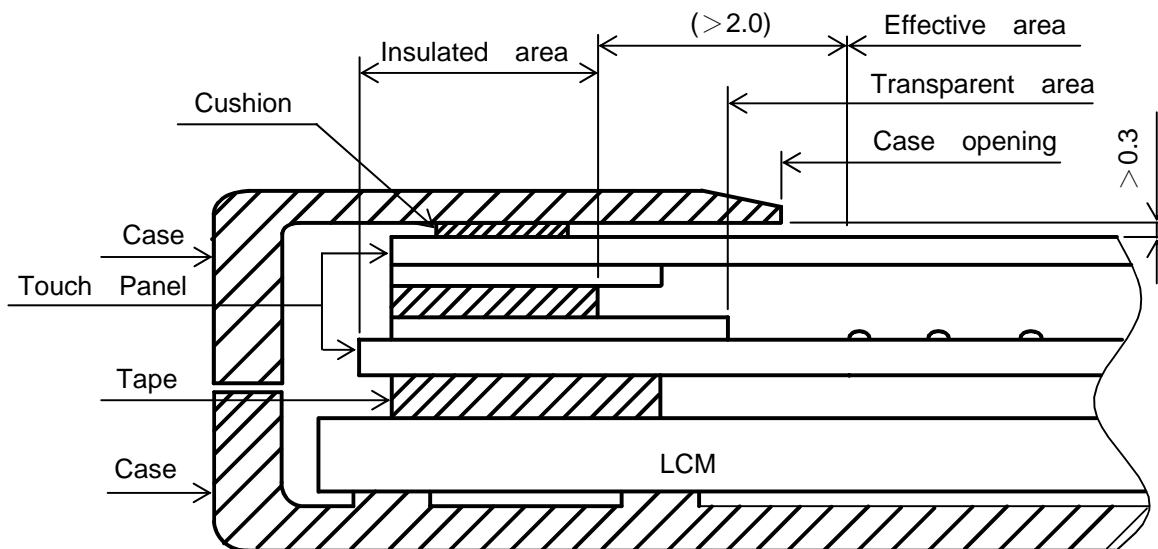

Fig 13.1

13.2 PRECAUTIONS of ESD

- 1) Before handling the display, please ensure your body has been connected to ground to avoid any damages by ESD. Also, do not touch display's interface directly when assembling.
- 2) Please remove the protection film very slowly before turning on the display to avoid generating ESD.

13.3 PRECAUTIONS of HANDLING

- 1) In order to keep the appearance of display in good condition, please do not rub any surfaces of the displays by sharp tools harder than 3H, especially touch panel, metal frame and polarizer.
- 2) Please do not pile the displays in order to avoid any scars leaving on the display. In order to avoid any injuries, please pay more attention for the edges of glasses and metal frame, and wear finger cots to protect yourself and the display before working on it.
- 3) Touching the display area or the terminal pins with bare hand is prohibited. This is because it will stain the display area and cause poor insulation between terminal pins, and might affect display's electrical characteristics furthermore.
- 4) Do not use any harmful chemicals such as acetone, toluene, and isopropyl alcohol to clean display's surfaces.
- 5) Please use soft cloth or absorbent cotton with ethanol to clean the display by gently wiping. Moreover, when wiping the display, please wipe it by horizontal or vertical direction instead of circling to prevent leaving scars on the display's surface, especially polarizer.

- 6) Please wipe any unknown liquids immediately such as saliva, water or dew on the display to avoid color fading or any permanently damages.
- 7) Maximum pressure to the surface of the display must be less than $1,96 \times 10^4$ Pa. If the area of adding pressure is less than 1 cm^2 , the maximum pressure must be less than 1.96N.

13.4 PRECAUTIONS OF OPERATING

- 1) Please input signals and voltages to the displays according to the values defined in the section of electrical characteristics to obtain the best performance. Any voltages over than absolute maximum rating will cause permanent damages to this display. Also, any timing of the signals out of this specification would cause unexpected performance.
- 2) When the display is operating at significant low temperature, the response time will be slower than it at 25 C° . In high temperature, the color will be slightly dark and blue compared to original pattern. However, these are temperature-related phenomenon of LCD and it will not cause permanent damages to the display when used within the operating temperature.
- 3) The use of screen saver or sleep mode is recommended when static images are likely for long periods of time. This is to avoid the possibility of image sticking.
- 4) Spike noise can cause malfunction of the circuit. The recommended limitation of spike noise is no bigger than $\pm 100 \text{ mV}$.

13.5 PRECAUTIONS of STORAGE

If the displays are going to be stored for years, please be aware the following notices.

- 1) Please store the displays in a dark room to avoid any damages from sunlight and other sources of UV light.
- 2) The recommended long term storage temperature is between $10 \text{ C}^\circ \sim 35 \text{ C}^\circ$ and 55%~75% humidity to avoid causing bubbles between polarizer and LCD glasses, and polarizer peeling from LCD glasses.
- 3) It would be better to keep the displays in the container, which is shipped from KOE, and do not unpack it.
- 4) Please do not stick any labels on the display surface for a long time, especially on the polarizer.

14. DESIGNATION of LOT MARK

1) The lot mark is showing in Fig.14.3. First 4 digits are used to represent production lot, T represented made in Taiwan, and the last 6 digits are the serial number.

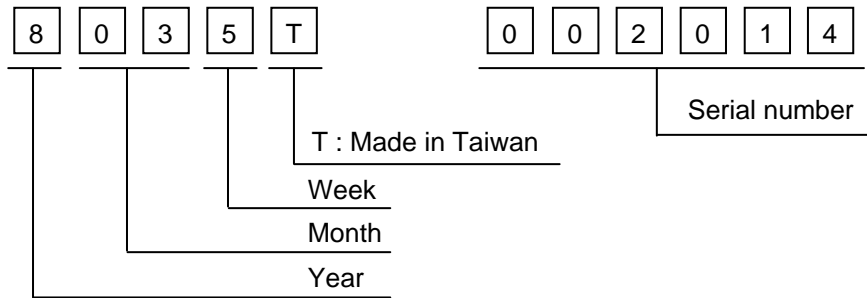

2) The tables as below are showing what the first 4 digits of lot mark are shorted for.

Year	Mark
2012	2
2013	3
2014	4
2015	5
2016	6

Month	Mark	Month	Mark
1	01	7	07
2	02	8	08
3	03	9	09
4	04	10	10
5	05	11	11
6	06	12	12

Week (Days)	Mark
1~7	1
8~14	2
15~21	3
22~28	4
29~31	5

3) Except letters I and O, revision number will be shown on lot mark and following letters A to Z.

4) The location of the lot mark is on the back of the display shown in Fig. 14.3.

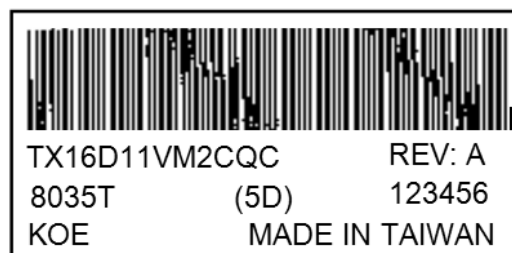

Fig 14.3