



Wah Wang Data Sheet for 1W Power LED

(Care should be take to the heat release matter when using this High Power LED)

Color	With Heatsink Part No:	Without Heatsink Part No:
White	WW-E101WL1-W4	WW-E101WL0-W4
Warm White	WW-E101TL1-W4	WW-E101TL0-W4
Nature White	WW-E101NL1-W4	WW-E101NL0-W4
Blue	WW-E101BL1-W4	WW-E101BL0-W4
Green	WW-E101GL1-W4	WW-E101GL0-W4
Yellow	WW-E101YL1-W2	WW-E101YL0-W2
Red	WW-E101RL1-W2	WW-E101RL0-W2



Address : Unit 03B, 18th Floor, Nanyang Plaza,
No.57 Hung To Road, Kwun Tong,
Kowloon, Hong Kong
Tel : 852-2512 9939 (10 line)
Fax : 852-2344 2398
Web Site : www.wahwang.com



Wah Wang High Power One Watt Series

Technical Datasheet

High Power One Watt LED series is designed for high current operation and high flux output applications. Furthermore, its thermal management characteristic is better than other LED Solutions. By package SMD design and good thermal emission material.

According to these advantages, it enables to apply various lighting applications and design solution, automotive lighting, and large size LCD backlight etc.



Features

- Super high Flux output and high Luminance
- Very long operating life (up to 50k hours)
- Designed for high current operation
- Low thermal resistance
- SMT solders ability
- Lead Free product
- RoHS compliant
- No UV
- Superior ESD protection

Application

- Mobile phone flash
- Automotive interior / exterior lighting
- Automotive signal lighting
- Automotive forward lighting
- General Torch
- Architectural lighting
- LCD TV / Monitor Backlight
- Projector light source
- Traffic signals
- Task lighting
- Decorative / Pathway lighting
- Remote / Solar powered lighting
- Household appliances



Outline Dimensions

Dome Type

TOP VIEW

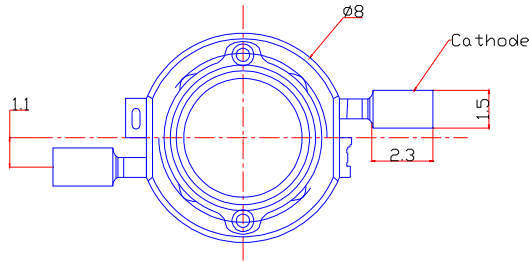

BOTTOM VIEW

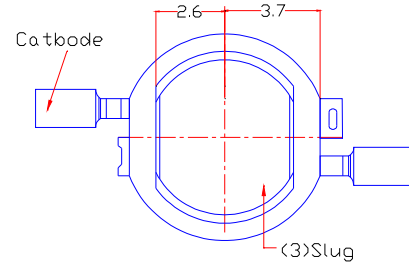

Drawings not to scale

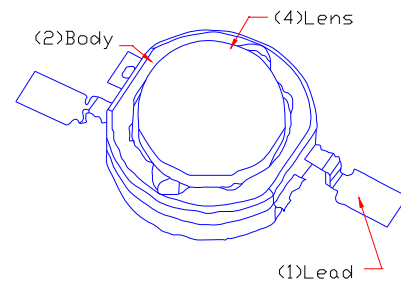
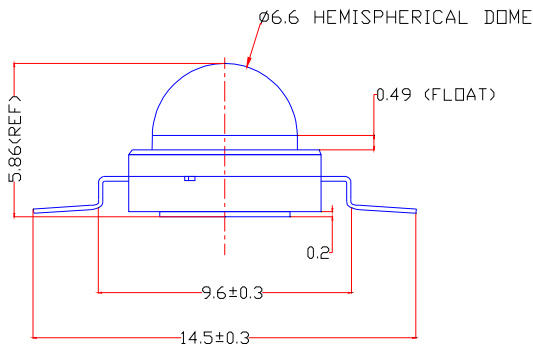

Notes:

1. All dimensions are in millimeter.
2. The anode side of the device is denoted by a hole in the lead frame. Electrical insulation between the case and the board is required-slug of device is not electrically neutral. Do not electrically connect either the anode or cathode to the slug.
3. All dimensions without tolerances are for reference only.
4. Caution must be used in handling this device to avoid damage to the lens surfaces that will reduce optical efficiency.



Recommended Solder pad

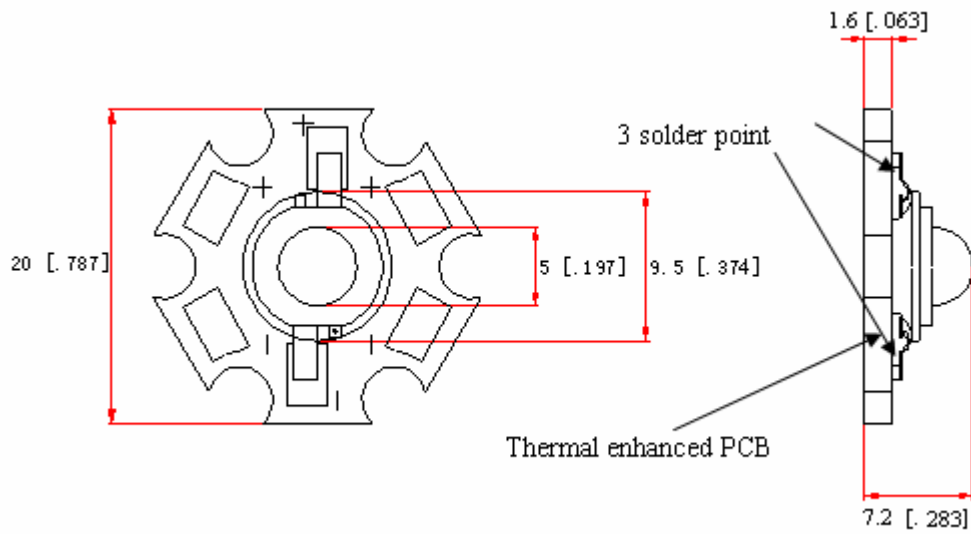

Note :

1. All dimensions are in millimeters
2. Scale none
3. This drawing without tolerances are for reference only

Hand Soldering Conditions

Lead : Not more than 3 seconds @MAX280°C

Slug: Use a thermal-adhesives

* Caution

No second soldering recommended



Characteristics for 1W Warm White Power LED

Electro-Optical characteristics at IF=350mA, TA=25°C

PART NO.	WW-E101TL1-W4 WW-E101TL0-W4	Code	BW1	Colour rank	ABCD1-4(page15)	
Parameter	Symbol	Value			Unit	
		Min	Typ	Max		
Luminous Flux	Φ_v	36	46	-	Lm	
Correlated Color Temperature	CCT	-	3000	-	K	
CRI	R_a	70	75	-	-	
Forward Voltage	V_F	-	3.2	4.5	V	
View Angle	2 Θ 1/2	140			deg.	

PART NO.	WW-E101TL1-W4 WW-E101TL0-W4	Code	AW1	Colour rank	ABCD1-4(page15)	
Parameter	Symbol	Value			Unit	
		Min	Typ	Max		
Luminous Flux	Φ_v	46	60	-	Lm	
Correlated Color Temperature	CCT	-	3000	-	K	
CRI	R_a	70	75	-	-	
Forward Voltage	V_F	-	3.2	4.5	V	
View Angle	2 Θ 1/2	140			deg.	

PART NO.	WW-E101TL1-W4 WW-E101TL0-W4	Code	HW1	Colour rank	ABCD1-4(page15)	
Parameter	Symbol	Value			Unit	
		Min	Typ	Max		
Luminous Flux	Φ_v	60	70	-	Lm	
Correlated Color Temperature	CCT	-	3000	-	K	
CRI	R_a	70	75	-	-	
Forward Voltage	V_F	-	3.2	4.5	V	
View Angle	2 Θ 1/2	140			deg.	

PART NO.	WW-E101TL1-W4 WW-E101TL0-W4	Code	CW5	Colour rank	ABCD1-4(page15)	
Parameter	Symbol	Value			Unit	
		Min	Typ	Max		
Luminous Flux	Φ_v	70	80	-	Lm	
Correlated Color Temperature	CCT	-	3000	-	K	
CRI	R_a	70	75	-	-	
Forward Voltage	V_F	-	3.2	4.0	V	
View Angle	2 Θ 1/2	140			deg.	



Characteristics for 1W Nature White Power LED

Electro-Optical characteristics at IF=350mA, TA=25°C\

PART NO.	WW-E101NL1-W4 WW-E101NL0-W4	Code	BW2	Colour rank	EFG1-3 (page16)	
Parameter	Symbol	Value			Unit	
		Min	Typ	Max		
Luminous Flux	Φ_v	36	46	-	Lm	
Correlated Color Temperature	CCT	-	4000	-	K	
CRI	R_a	70	75	-	-	
Forward Voltage	V_F	-	3.2	4.5	V	
View Angle	2 Θ 1/2	140			deg.	

PART NO.	WW-E101NL1-W4 WW-E101NL0-W4	Code	AW2	Colour rank	EFG1-3 (page16)	
Parameter	Symbol	Value			Unit	
		Min	Typ	Max		
Luminous Flux	Φ_v	46	60	-	Lm	
Correlated Color Temperature	CCT	-	4000	-	K	
CRI	R_a	70	75	-	-	
Forward Voltage	V_F	-	3.2	4.5	V	
View Angle	2 Θ 1/2	140			deg.	

PART NO.	WW-E101NL1-W4 WW-E101NL0-W4	Code	HW2	Colour rank	EFG1-3 (page16)	
Parameter	Symbol	Value			Unit	
		Min	Typ	Max		
Luminous Flux	Φ_v	60	70	-	Lm	
Correlated Color Temperature	CCT	-	4000	-	K	
CRI	R_a	70	75	-	-	
Forward Voltage	V_F	-	3.2	4.5	V	
View Angle	2 Θ 1/2	140			deg.	

PART NO.	WW-E101NL1-W4 WW-E101NL0-W4	Code	CW2	Colour rank	EFG1-3 (page16)	
Parameter	Symbol	Value			Unit	
		Min	Typ	Max		
Luminous Flux	Φ_v	70	80	-	Lm	
Correlated Color Temperature	CCT	-	4000	-	K	
CRI	R_a	70	75	-	-	
Forward Voltage	V_F	-	3.2	4.0	V	
View Angle	2 Θ 1/2	140			deg.	



Characteristics for 1W White Power LED

Electro-Optical characteristics at IF=350mA, TA=25°C

PART NO.	WW-E101WL1-W4 WW-E101WL0-W4	Code	BW3	Colour rank	I1 I2 I3 J1 J2 J3 K1 K2 K3 (page14)				
					Parameter	Symbol	Value		
					Min	Typ	Max		
					46	60	-	Lm	
					-	6000	-	K	
					70	75	-	-	
					-	3.2	4.5	V	
					2θ1/2			140	deg.

PART NO.	WW-E101WL1-W4 WW-E101WL0-W4	Code	AW3	Colour rank	I1 I2 I3 J1 J2 J3 K1 K2 K3 (page14)				
					Parameter	Symbol	Value		
					Min	Typ	Max		
					60	70	-	Lm	
					-	6000	-	K	
					70	75	-	-	
					-	3.2	4.5	V	
					2θ1/2			140	deg.

PART NO.	WW-E101WL1-W4 WW-E101WL0-W4	Code	HW3	Colour rank	I1 I2 I3 J1 J2 J3 K1 K2 K3 (page14)				
					Parameter	Symbol	Value		
					Min	Typ	Max		
					70	80	-	Lm	
					-	6000	-	K	
					70	75	-	-	
					-	3.2	4.5	V	
					2θ1/2			140	deg.

PART NO.	WW-E101WL1-W4 WW-E101WL0-W4	Code	CW3	Colour rank	I1 I2 I3 J1 J2 J3 K1 K2 K3 (page14)				
					Parameter	Symbol	Value		
					Min	Typ	Max		
					80	90	-	Lm	
					-	6000	-	K	
					70	75	-	-	
					-	3.2	4.0	V	
					2θ1/2			140	deg.



Characteristics for 1W White Power LED

Electro-Optical characteristics at IF=350mA, TA=25°C

PART NO.	WW-E101WL1-W4 WW-E101WL0-W4	Code	BW4	Colour rank	L1M1(page14)	
Parameter	Symbol	Value			Unit	
		Min	Typ	Max		
Luminous Flux	Φ_v	36	46	-	Lm	
Correlated Color Temperature	CCT	-	8500	-	K	
CRI	R_a	70	75	-	-	
Forward Voltage	V_F	-	3.2	4.5	V	
View Angle	2 Θ 1/2	140			deg.	

PART NO.	WW-E101WL1-W4 WW-E101WL0-W4	Code	AW4	Colour rank	L1M1(page14)	
Parameter	Symbol	Value			Unit	
		Min	Typ	Max		
Luminous Flux	Φ_v	46	60	-	Lm	
Correlated Color Temperature	CCT	-	8500	-	K	
CRI	R_a	70	75	-	-	
Forward Voltage	V_F	-	3.2	4.5	V	
View Angle	2 Θ 1/2	140			deg.	

PART NO.	WW-E101WL1-W4 WW-E101WL0-W4	Code	HW4	Colour rank	L1M1(page14)	
Parameter	Symbol	Value			Unit	
		Min	Typ	Max		
Luminous Flux	Φ_v	60	70	-	Lm	
Correlated Color Temperature	CCT	-	8500	-	K	
CRI	R_a	70	75	-	-	
Forward Voltage	V_F	-	3.2	4.5	V	
View Angle	2 Θ 1/2	140			deg.	

PART NO.	WW-E101WL1-W4 WW-E101WL0-W4	Code	CW4	Colour rank	L1M1(page14)	
Parameter	Symbol	Value			Unit	
		Min	Typ	Max		
Luminous Flux	Φ_v	70	80	-	Lm	
Correlated Color Temperature	CCT	-	8500	-	K	
CRI	R_a	70	75	-	-	
Forward Voltage	V_F	-	3.2	4.0	V	
View Angle	2 Θ 1/2	140			deg.	



Characteristics for 1W Red Power LED

Electro-Optical characteristics at IF=350mA, TA=25°C

PART NO.	WW-E101RL1-W2 WW-E101RL0-W2	Code	HR1			
			Min	Typ	Max	
Parameter	Symbol		Value			Unit
			Min	Typ	Max	
Luminous Flux	Φ_v		21	27	-	Lm
Dominant Wavelength	λ_d		620	-	630	nm
Forward Voltage	V_F		-	2.0	2.8	V
View Angle	2 θ 1/2		120			deg.

PART NO.	WW-E101RL1-W2 WW-E101RL0-W2	Code	HR2			
			Min	Typ	Max	
Parameter	Symbol		Value			Unit
			Min	Typ	Max	
Luminous Flux	Φ_v		27	36	-	Lm
Dominant Wavelength	λ_d		620	-	630	nm
Forward Voltage	V_F		-	2.0	2.8	V
View Angle	2 θ 1/2		120			deg.

PART NO.	WW-E101RL1-W2 WW-E101RL0-W2	Code	PR1			
			Min	Typ	Max	
Parameter	Symbol		Value			Unit
			Min	Typ	Max	
Luminous Flux	Φ_v		36	46	-	Lm
Dominant Wavelength	λ_d		620	-	630	nm
Forward Voltage	V_F		-	2.0	2.8	V
View Angle	2 θ 1/2		120			deg.

Characteristics for 1W Green Power LED

Electro-Optical characteristics at IF=350mA, TA=25°C

PART NO.	WW-E101GL1-W4 WW-E101GL0-W4	Code	HG1			
			Min	Typ	Max	
Parameter	Symbol		Value			Unit
			Min	Typ	Max	
Luminous Flux	Φ_v		60	70	-	Lm
Dominant Wavelength	λ_d		515	-	525	nm
Forward Voltage	V_F		-	3.2	4.5	V
View Angle	2 θ 1/2		140			deg.



Characteristics for 1W Blue Power LED

Electro-Optical characteristics at IF=350mA, TA=25°C

PART NO.	WW-E101BL1-W4 WW-E101BL0-W4	Code	AB1		
Parameter	Symbol	Value			Unit
		Min	Typ	Max	
Luminous Flux	Φ_v	12	16	-	Lm
Dominant Wavelength	λ_d	460	-	470	nm
Forward Voltage	V_F	-	3.2	4.5	V
View Angle	2 θ 1/2	140			deg.

Characteristics for 1W Yellow Power LED

Electro-Optical characteristics at IF=350mA, TA=25°C

PART NO.	WW-E101YL1-W2 WW-E101YL0-W2	Code	HY1		
Parameter	Symbol	Value			Unit
		Min	Typ	Max	
Luminous Flux	Φ_v	21	27	-	Lm
Dominant Wavelength	λ_d	585	-	595	nm
Forward Voltage	V_F	-	2.0	2.8	V
View Angle	2 θ 1/2	120			deg.

PART NO.	WW-E101YL1-W2 WW-E101YL0-W2	Code	HY2		
Parameter	Symbol	Value			Unit
		Min	Typ	Max	
Luminous Flux	Φ_v	36	46	-	Lm
Dominant Wavelength	λ_d	585	-	595	nm
Forward Voltage	V_F	-	2.0	2.8	V
View Angle	2 θ 1/2	120			deg.

Absolute Maximum Ratings

Parameter	Symbol	Value	Unit
Forward Current	I_F	0.5	A
Power Dissipation	P_D	1.6	W
Junction Temperature	T_j	125	°C
Operating Temperature	T_{opr}	-30~+85	°C
Storage Temperature	T_{stg}	-40~+120	°C

*Notes:

- [1] WW maintains a tolerance of $\pm 10\%$ on flux and power measurements.
- [2] CCT $\pm 5\%$ tester tolerance and $\lambda_d \pm 1\text{nm}$
- [3] A tolerance of $\pm 0.1\text{V}$ on forward voltage measurements
- [4] View Angle maintains a tolerance of $\pm 20^\circ$

* Caution



White color spectrum, TA=25°C

Pure White

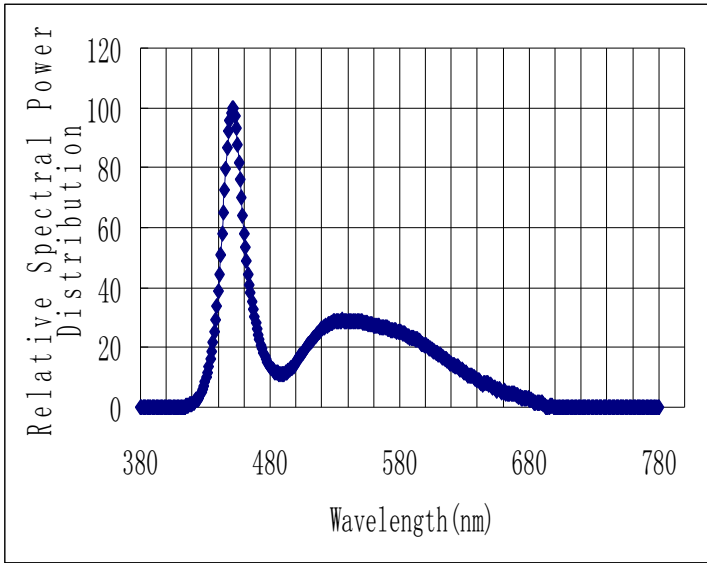

Warm white

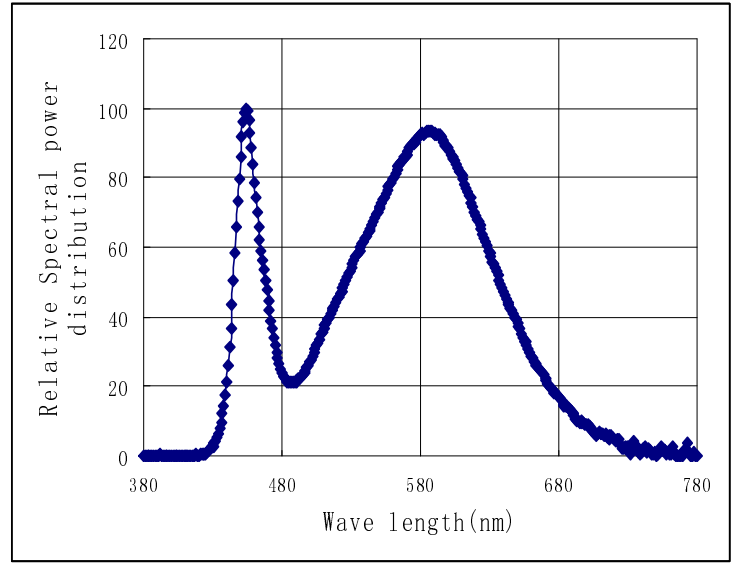

Red Green Blue Yellow

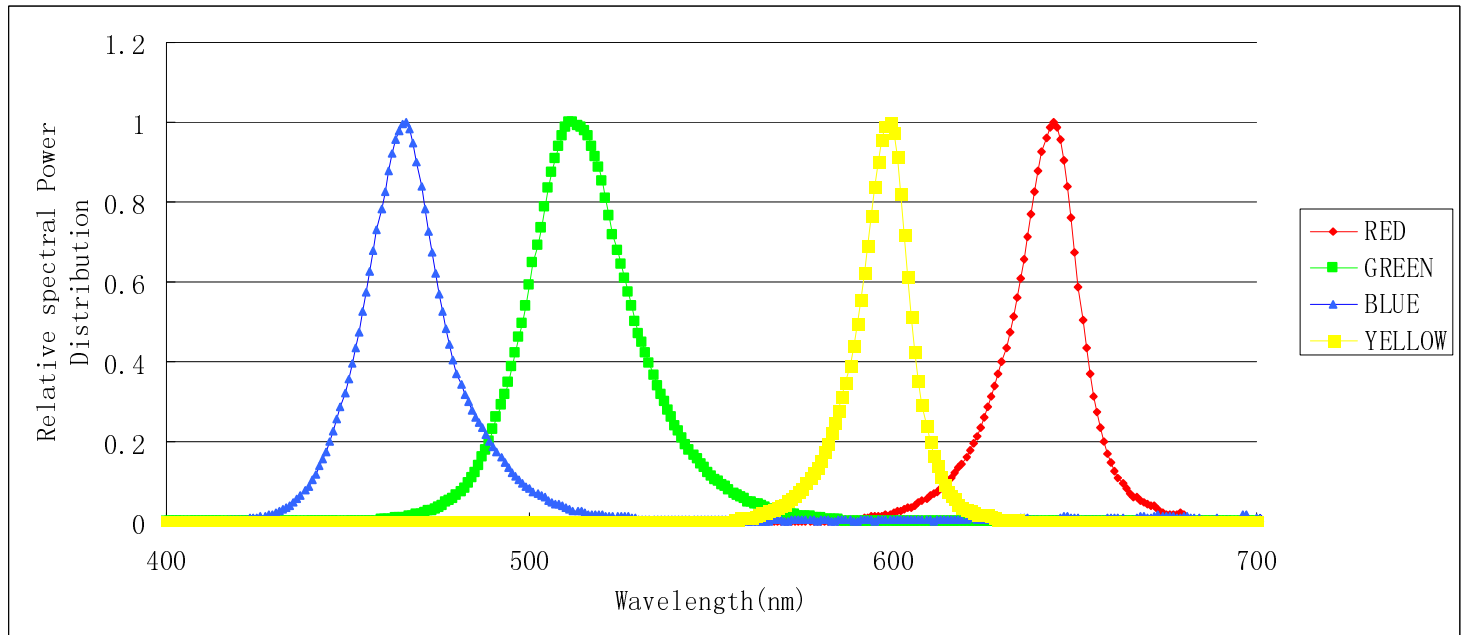

Forward Voltage vs. Forward Current, TA=25°C (White Blue Green)

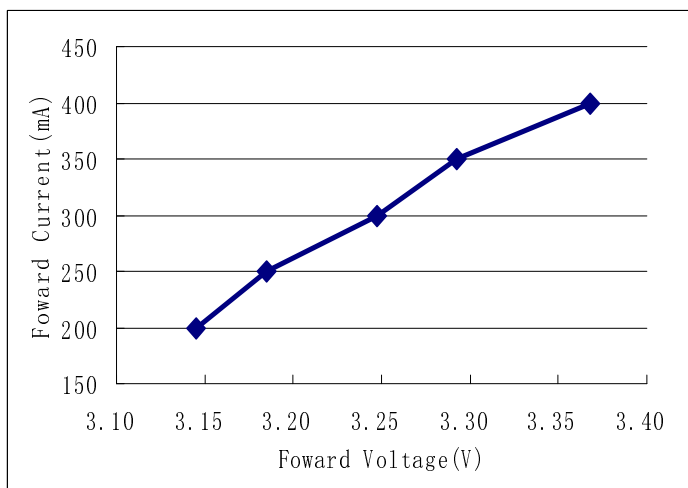

Forward Voltage vs. Forward Current, TA=25°C (Red Yellow)

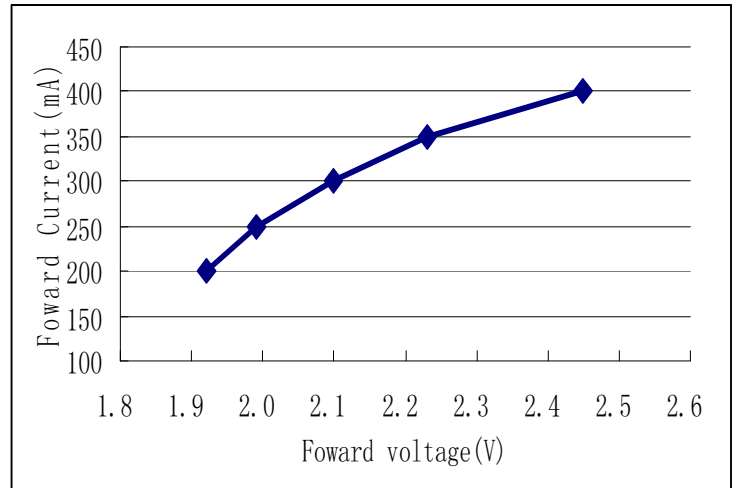



**Typical Dome Type Radiation pattern
(Angle : 140°)**

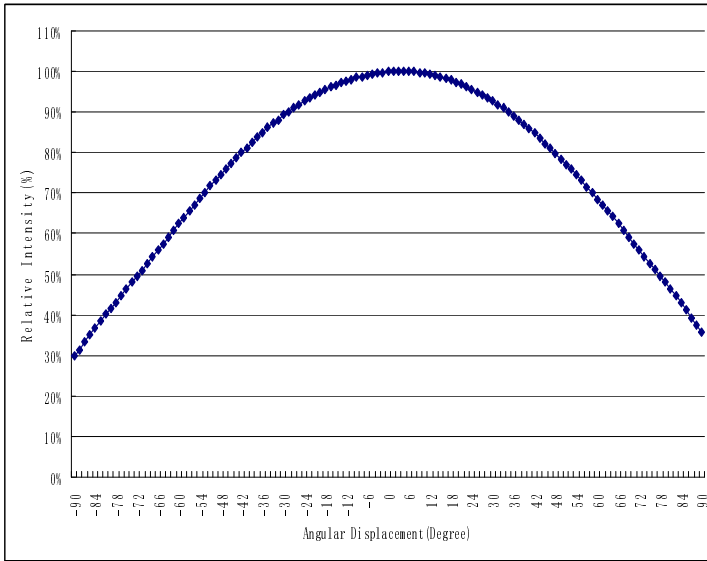

**Typical Dome Type Radiation pattern
Angle : 120°**

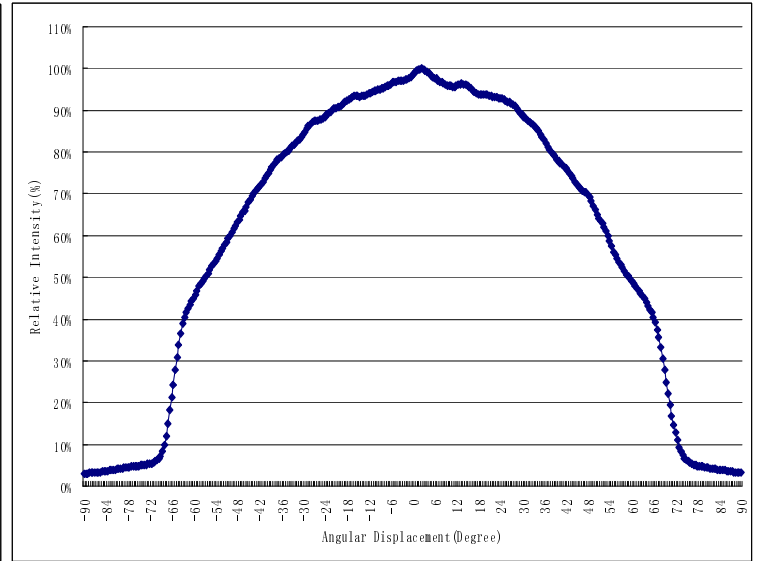

**Relative Light Output vs. Junction Temperature
IF=350mA, at TA=25°C**

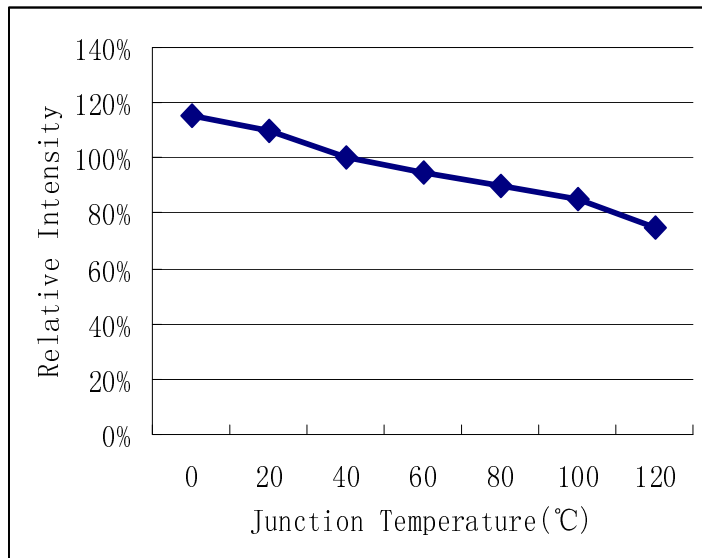

**Forward Current VS Relative Luminosity TA=25°C
(White Blue Green Yellow Red)**

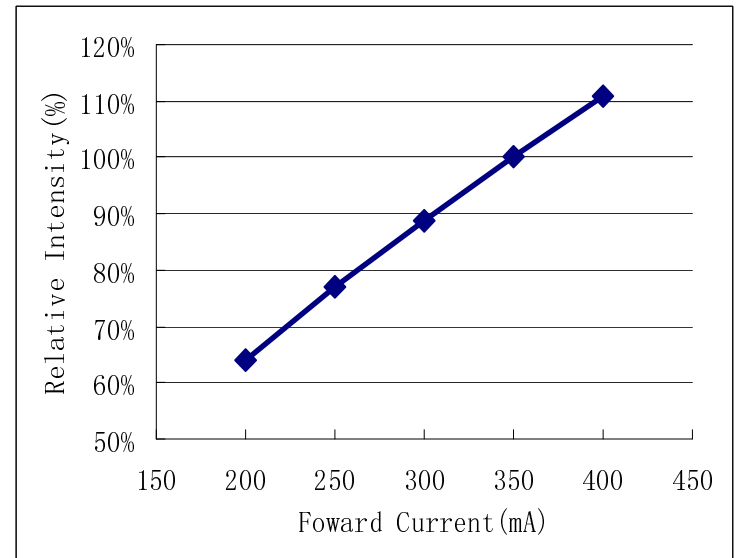

**Forward Current VS Chromaticity Coordinate:
TA=25°C (Pure white)**

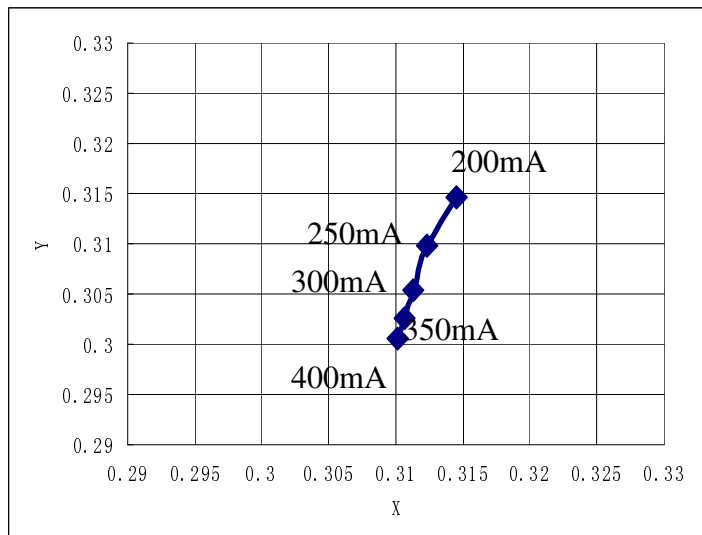

**Forward Current VS Chromaticity Coordinate:
TA=25°C (Warm white)**

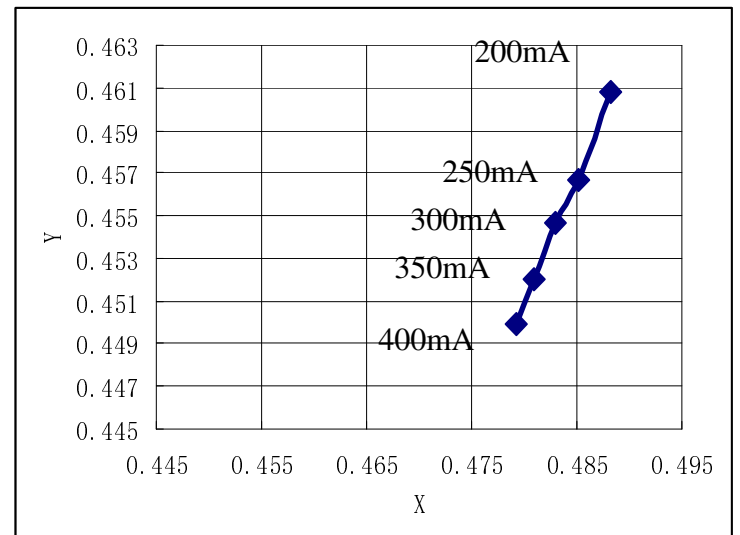



Ambient Temperature. VS Allowable Forward Current (All series)

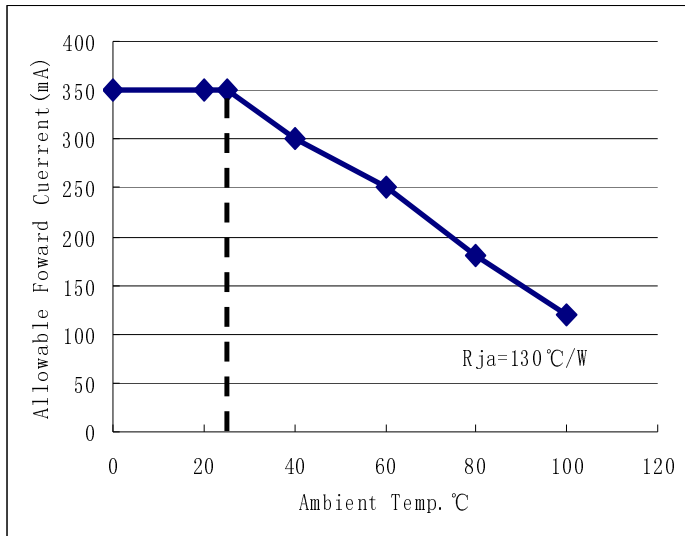

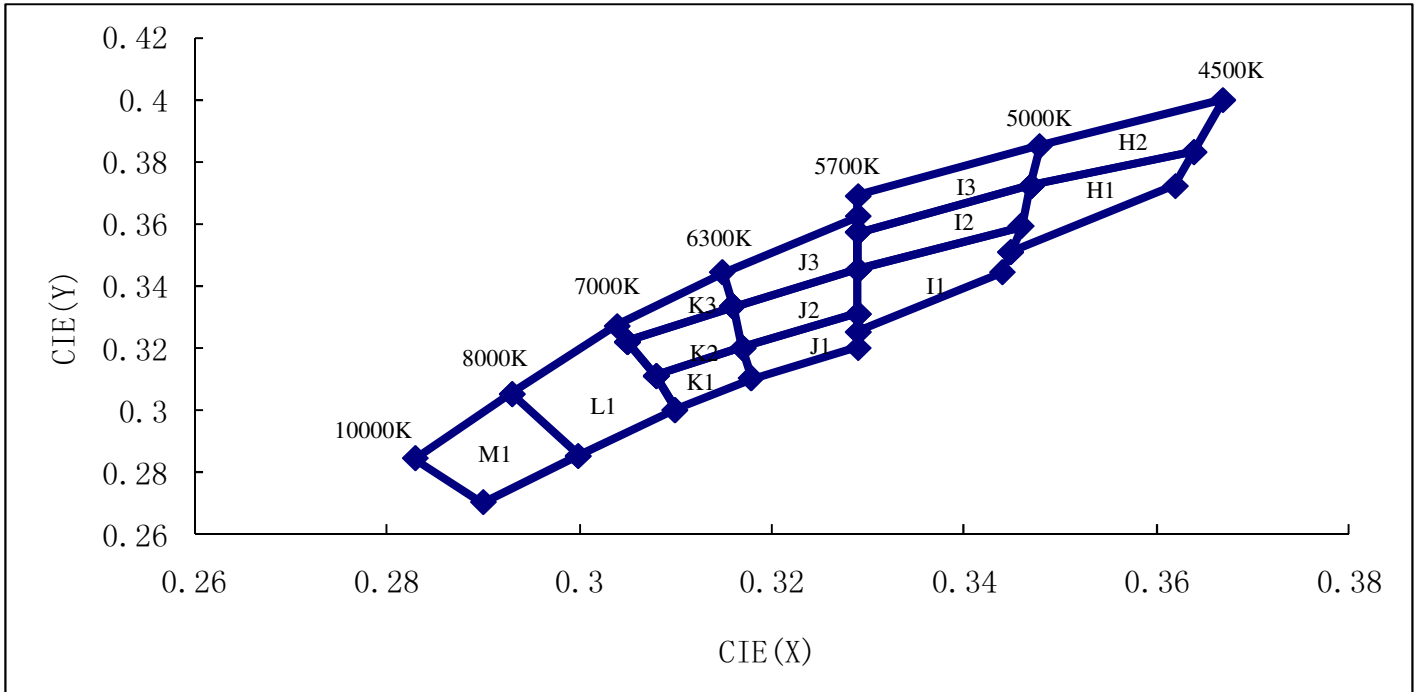

BIN	CHR-X	CHR-Y	TC(K)	BIN	CHR-X	CHR-Y	TC(K)
M1	0.293	0.305	9000	J1	0.329	0.331	6050
	0.283	0.284			0.317	0.32	
	0.29	0.27			0.318	0.31	
	0.3	0.285			0.329	0.32	
L1	0.304	0.327	7500	I3	0.329	0.325	5350
	0.293	0.305			0.348	0.385	
	0.3	0.285			0.329	0.369	
	0.31	0.3			0.329	0.362	
	0.308	0.311			0.329	0.357	
K3	0.315	0.344	6700	I2	0.347	0.372	5350
	0.304	0.327			0.329	0.357	
	0.305	0.322			0.329	0.345	
	0.316	0.333			0.346	0.359	
K2	0.316	0.333	6700	I1	0.346	0.359	5350
	0.305	0.322			0.329	0.345	
	0.308	0.311			0.329	0.331	
	0.317	0.32			0.329	0.325	
K1	0.317	0.32	6700	H2	0.344	0.344	4800
	0.308	0.311			0.345	0.351	
	0.31	0.3			0.367	0.4	
	0.318	0.31			0.348	0.385	
J3	0.329	0.362	6050	H1	0.347	0.372	4800
	0.315	0.344			0.364	0.383	
	0.316	0.333			0.364	0.383	
	0.329	0.345			0.347	0.372	
	0.329	0.357			0.346	0.359	
J2	0.329	0.345	6050		0.345	0.351	
	0.316	0.333		0.362	0.372		
	0.317	0.32					
	0.329	0.331					

Remark:J1 J2 K1 K2 I1 (White and Purplish) J2 J3 K2 K3 (White and lightly Yellowish)
 I2 I3 H1 H2 (White and deeply Yellowish) Customer can choose any group

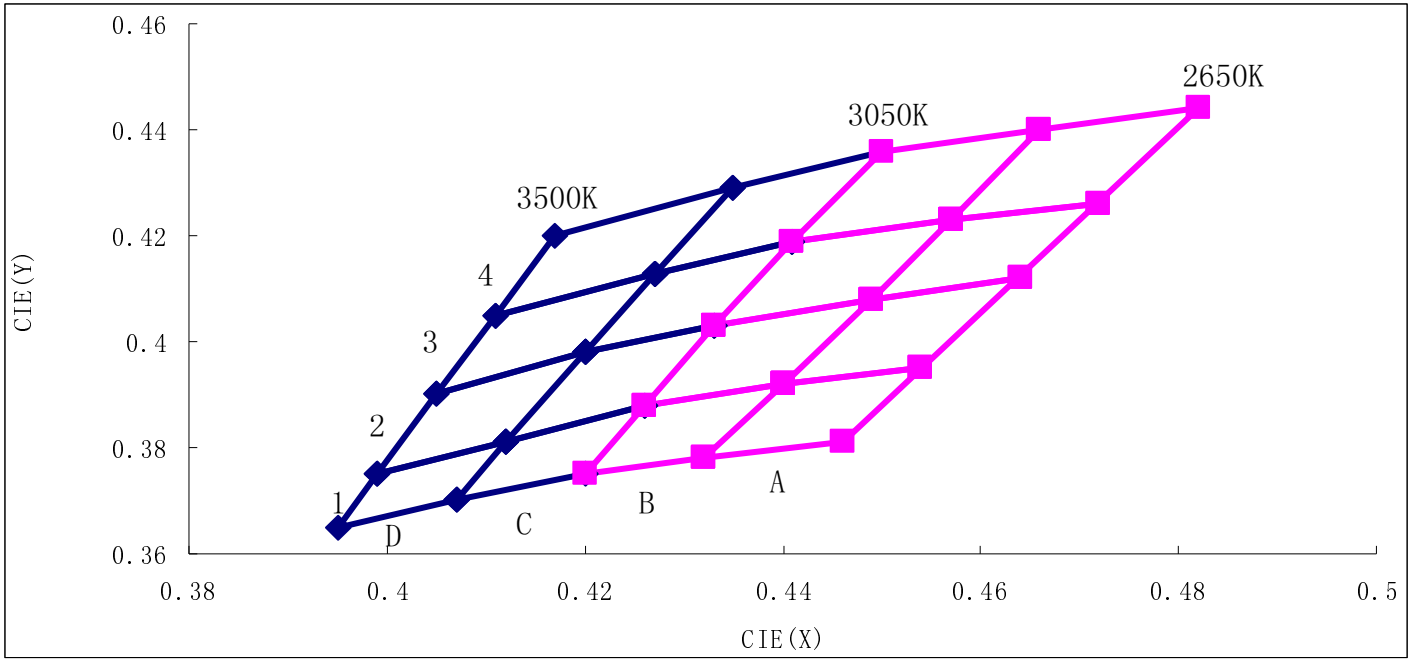

BIN	CHR-X	CHR-Y	TC (K)	BIN	CHR-X	CHR-Y	TC (K)
D4	0.435	0.429	3375	B4	0.466	0.44	2950
	0.417	0.42			0.45	0.436	
	0.411	0.405			0.441	0.419	
	0.427	0.413			0.457	0.423	
D3	0.427	0.413	3375	B3	0.457	0.423	2950
	0.411	0.405			0.441	0.419	
	0.405	0.39			0.433	0.403	
	0.42	0.398			0.449	0.408	
D2	0.42	0.398	3375	B2	0.449	0.408	2950
	0.405	0.39			0.433	0.403	
	0.399	0.375			0.426	0.388	
	0.412	0.381			0.44	0.392	
D1	0.412	0.381	3375	B1	0.44	0.392	2950
	0.399	0.375			0.426	0.388	
	0.395	0.365			0.42	0.375	
	0.407	0.37			0.432	0.378	
C4	0.45	0.436	3250	A4	0.482	0.444	2750
	0.435	0.429			0.466	0.44	
	0.427	0.413			0.457	0.423	
	0.441	0.419			0.472	0.426	
C3	0.441	0.419	3150	A3	0.472	0.426	2750
	0.427	0.413			0.457	0.423	
	0.42	0.398			0.449	0.408	
	0.433	0.403			0.464	0.412	
C2	0.433	0.403	3150	A2	0.464	0.412	2750
	0.42	0.398			0.449	0.408	
	0.412	0.381			0.44	0.392	
	0.426	0.388			0.454	0.395	
C1	0.426	0.388	3150	A1	0.454	0.395	2750
	0.412	0.381			0.44	0.392	
	0.407	0.37			0.432	0.378	
	0.42	0.375			0.446	0.381	



BIN	CHR-X	CHR-Y	TC (K)	BIN	CHR-X	CHR-Y	TC (K)
G3	0.38	0.4	4325	F1	0.387	0.374	3985
	0.365	0.389			0.372	0.364	
	0.362	0.373			0.369	0.35	
	0.376	0.382			0.382	0.358	
G2	0.376	0.382	4325	E3	0.417	0.42	3660
	0.362	0.373			0.398	0.411	
	0.359	0.356			0.392	0.391	
	0.372	0.364			0.409	0.4	
G1	0.372	0.364	4325	E2	0.409	0.4	3660
	0.359	0.356			0.392	0.391	
	0.356	0.341			0.387	0.374	
	0.369	0.35			0.402	0.382	
F3	0.398	0.411	3985	E1	0.402	0.382	3660
	0.38	0.4			0.387	0.374	
	0.376	0.382			0.382	0.358	
	0.392	0.391			0.396	0.367	
F2	0.392	0.391	3985				
	0.376	0.382					
	0.372	0.364					
	0.387	0.374					

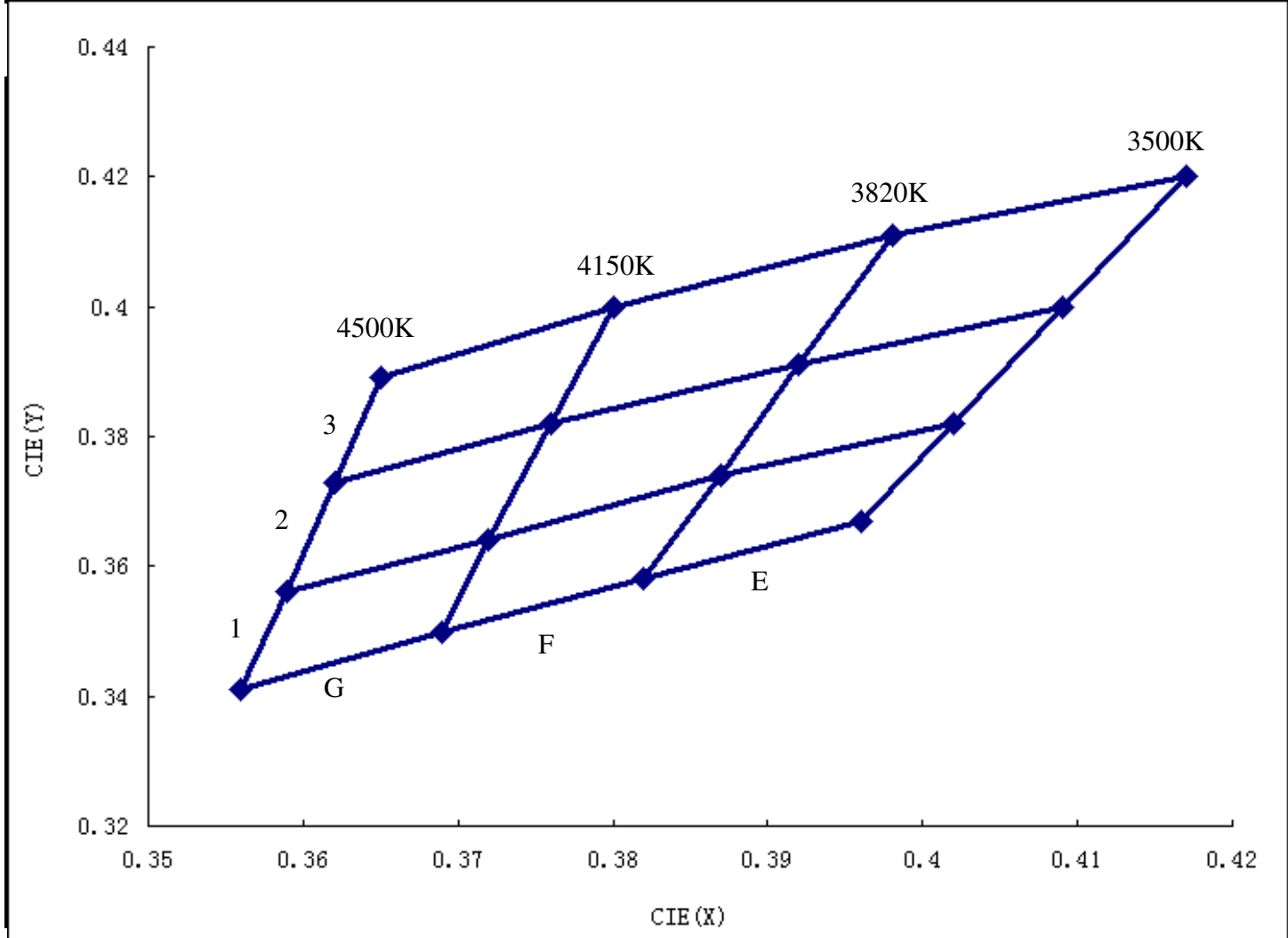



Life Test decay: IF=350mA TA=25°C Heart sink: 30*30 aluminum board with thermal conductivity ($\lambda=30$ w/mk)

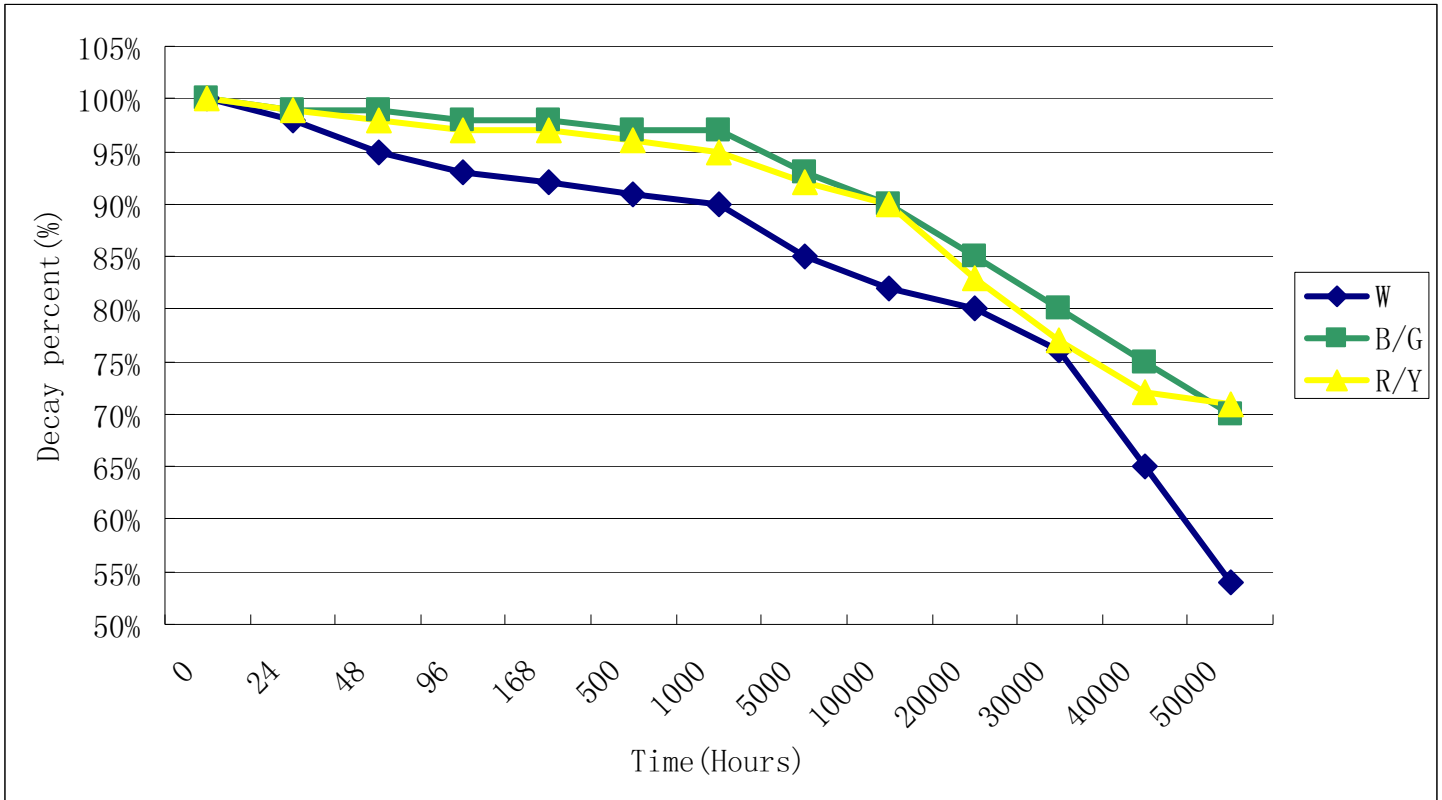

Caution: Because high temperature will fasten LED life decay, when you do high power LED life test, Please be sure LED have a good heat dissipation . 30*30 aluminum board with thermal conductivity of $\lambda =30$ w/mk be suggested.



Packing

1、 Package without heart sink LED (50pcs/tube)

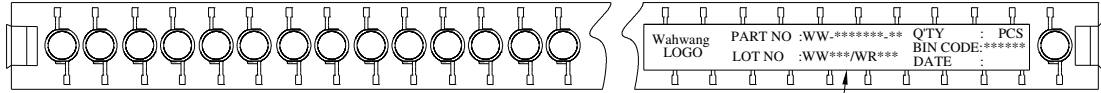
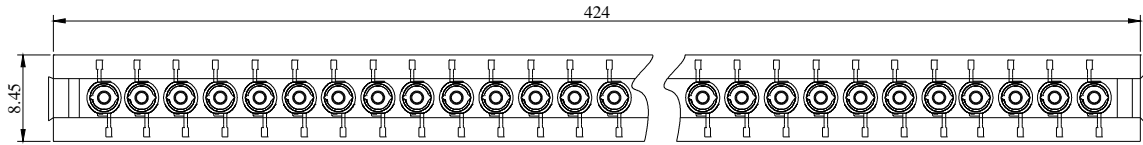

Wahwang LOGO	PART NO :WW_*****_**	Q'TY : PCS
	LOT NO :WW***/WR**	BIN CODE:*****
		DATE :

2、 Package with heart sink LED (50pcs/tray)

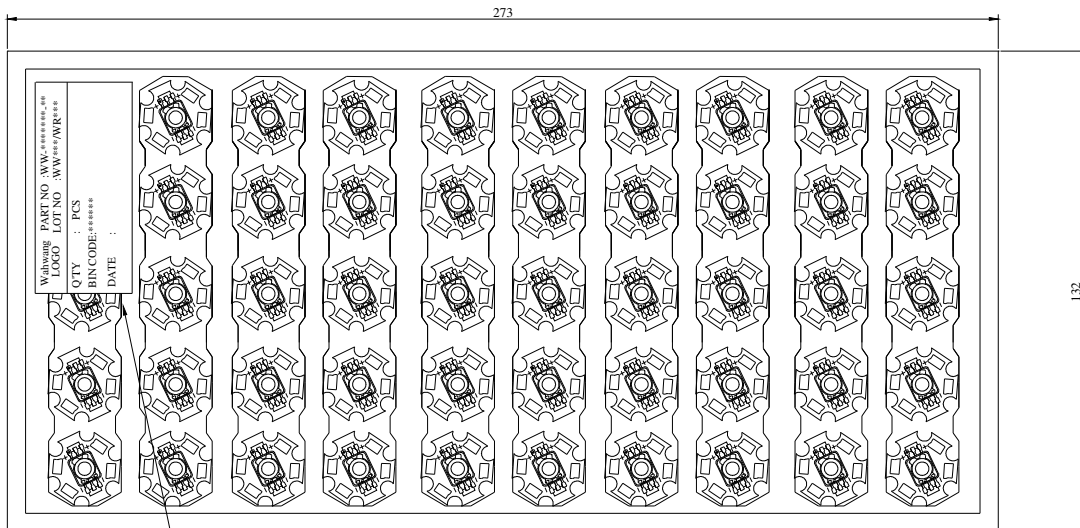

Wahwang LOGO	PART NO :WW_*****_**
	LOT NO :WW***/WR**
Q'TY : PCS	
BIN CODE:*****	
DATE :	

BIN CODE: * ** ** ****

- 1: Order Rank
- 2: IV Rank (sheet 1)
- 3: Colour rank or Dominant wavelength rank (sheet 2)
- 4: VF rank (sheet 3)



Bin Code Definition for delivery

Sheet 1

BIN CODE	IV (lm)	BIN CODE	IV (lm)
01	3-6	10	60-70
02	6-9	11	70-80
03	9-12	12	80-100
04	12-16	13	100-130
05	16-21	14	130-170
06	21-27	15	170-220
07	27-36	16	220-280
08	36-46	17	280-360
09	46-60	18	360-470

Sheet 2-1

BIN CODE	(nm)	BIN CODE	λd (nm)
RA	615-620	RE	635-640
RB	620-625	RF	640-645
RC	625-630	RG	645-650
RD	630-635	RH	650-655

Sheet 2-2

BIN CODE	λd (nm)	BIN CODE	λd (nm)
YA	580-582	YE	588-590
YB	582-584	YF	590-592
YC	584-586	YG	592-594
YD	586-588	YH	594-596

Sheet 2-3

BIN CODE	λd (nm)	BIN CODE	λd (nm)
GA	497-500	GH	518-521
GB	500-503	GI	521-524
GC	503-506	GJ	524-527
GD	506-509	GK	527-530
GE	509-512	GL	530-533
GF	512-515	GM	533-536
GG	515-518	GN	536-539

Sheet 2-4

BIN CODE	λd (nm)	BIN CODE	λd (nm)
BA	459-462	BD	468-471
BB	462-465	BE	471-474
BC	465-468	BF	474-477



Sheet3

BIN CODE	VF (V)	BIN CODE	VF (V)
A1	1.6-1.7	R1	3.3-3.4
B1	1.7-1.8	S1	3.4-3.5
C1	1.8-1.9	T1	3.5-3.6
D1	1.9-2.0	U1	3.6-3.7
E1	2.0-2.1	V1	3.7-3.8
F1	2.1-2.2	W1	3.8-3.9
G1	2.2-2.3	X1	3.9-4.0
H1	2.3-2.4	Y1	4.0-4.1
I1	2.4-2.5	Z1	4.1-4.2
J1	2.5-2.6	A2	4.2-4.3
K1	2.6-2.7	B2	4.3-4.4
L1	2.7-2.8	C2	4.4-4.5
M1	2.8-2.9	D2	4.5-4.6
N1	2.9-3.0	E2	4.6-4.7
O1	3.0-3.1	F2	4.7-4.8
P1	3.1-3.2	G2	4.8-4.9
Q1	3.2-3.3	H2	4.9-5.0



Precaution for use

- Storage

In order to avoid the absorption of moisture, it is recommended to store in the dry box (or desiccators) with a desiccant. Otherwise, to store them in the following environment is recommended. Temperature : 5°C~30°C Humidity : 60%HR max.

- Attention after opened

However LED is correspond SMD, when LED is soldered dip, interfacial separation may affect the light transmission efficiency, causing the light intensity to drop. Attention in followed.

a. After opened and mounted, the soldering shall be quickly.

b. Keeping of a fraction

Temperature : 5 ~ 40°C Humidity : less than 30%

- In case of more than 1 week passed after opening or change color of indicator on desiccant components shall be dried 10-12hr. at 60±5°C.
- In case of supposed the components is humid, shall be dried dip-solder just before. 100Hr at 80±5°C or 12Hr at 100±5°C.
- Any mechanical force or any excess vibration shall not be accepted to apply during cooling process to normal temp. after soldering.
- Quick cooling shall avoid.
- Components shall not be mounted on warped direction of PCB.
- Anti radioactive ray design is not considered for the products listed here in.
- Gallium arsenide is used in some of the products listed in this publication. These products are dangerous if they are burned or smashed in the process of disposal. It is also dangerous to drink the liquid or inhale the gas generated by such products when chemically disposed.
- This device should not be used in any type of fluid such as water, oil, organic solvent and etc. When washing is required, IPA should be used.
- When the LEDs are illuminating, operating current should be decided after considering the package maximum temperature.
- LEDs must be stored to maintain a clean atmosphere. If the LEDs are stored for 3 months or more after being shipped from WW, a sealed container with a nitrogen atmosphere should be used for storage.
- The LEDs must be soldered within seven days after opening the moisture-proof packing.
- Repack unused products with anti-moisture packing, fold to close any opening and then store in a dry place.
- The appearance and specifications of the product may be modified for improvement without notice.
- Long time exposure of sunlight or UV occasions discolorment of PKG

Handling of Silicone resin LEDs

WAHWANG LED is encapsulated by silicone resin for the highest flux efficiency.

Notes for handling of Silicone resin WAHWANG LEDs

- Avoid touching silicone resin parts especially by sharp tools such as Pinsetter (Tweezers)
- Avoid leaving fingerprints on silicone resin parts.
- Dust sensitivity silicone resin need containers having cover for storage.
- When populating boards in SMT production, there are basically no restrictions regarding the form of the pick and place nozzle, except that mechanical pressure on the surface of the resin must be prevent. This is assured by choosing a pick and place nozzle which is larger than the LEDs silicone resin area
- Please do not force over 3000 gf impact or pressure diagonally on the silicon lens. It will cause fatal damage of this product