

DISPENSING VALVE

MODEL VD510-UV

◀INSTRUCTION MANUAL▶

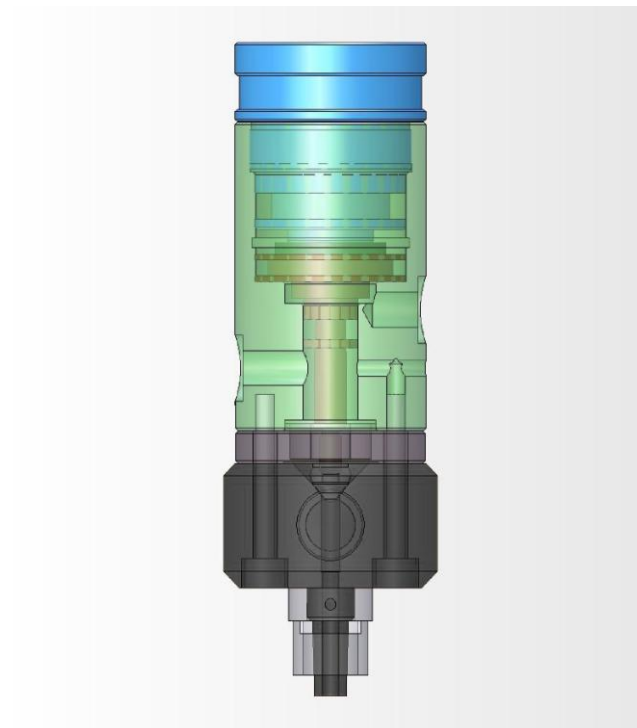

15 Corporate Drive, Suite E - Wayne - NJ 07470
Tel: (973) 646-5044 E-mail: info@fisnar.com
www.fisnar.com

CONTENTS

1 Introduction	page 3
2 Specifications	page 3
3 Part Description	page 4
4 Operation Principles	page 5
5 Operating Procedure	page 6
5-1 Setup	page 6
5-2 Maintenance	page 9
6 Sectional Drawing & Dimension	page 11
7 Exploded View & Parts List	page 12

1. INTRODUCTION

The VD510-UV is a diaphragm valve designed for precise flow control of low to medium viscosity materials (under 10,000 cps). The valve is ideal for dispensing UV curable materials. Shot sizes may be fine tuned by turning the stroke adjustment knob at the top of the valve.



2. SPECIFICATIONS

Operating Air Pressure	4.0~6.0kgf/cm ² (60-90)
Material Delivery Pressure	Max 5.0kgf/cm ²
Maximum Number of Cycle	500 cycles or more/min
Flux (KV value)	0.3ℓ/min
Minimum Shot Size	0.001 (material dependant)
Valve Structure	Diaphragm Valve
Weight	76g (2.7oz)
Driving Part Materials	Body : AL(Hard coated, Black) Piston : SUS303 Piston Seal : NBR
Wetted Part Materials	Valve Head : BLACK UHMW-PE (option :Teflon, PEEK, Acetal) Diaphragm : BLACK UHMW-PE
Connecting Ports	Operating Air Inlet: M5xP0.8 Material Inlet: BSPT1/8" Material Outlet: Luer Lock

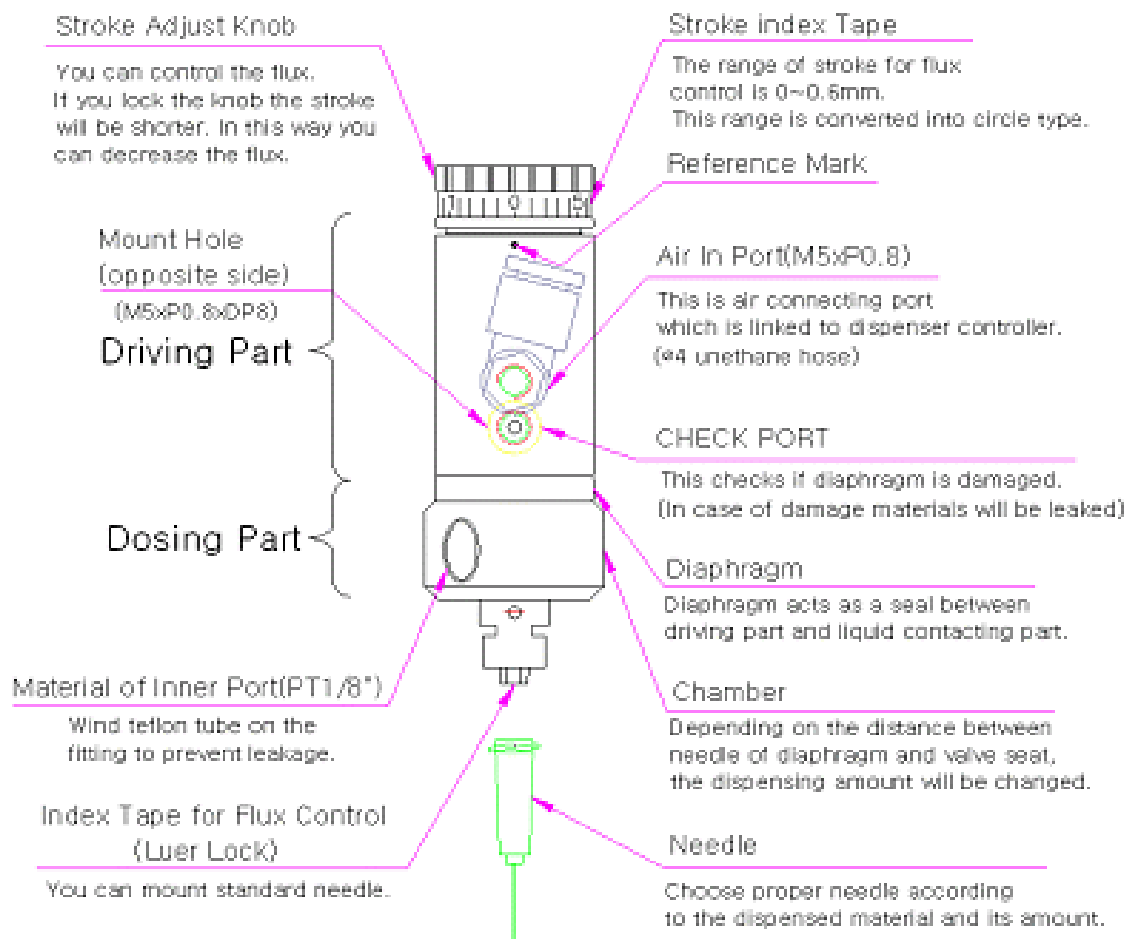
3. PART DESCRIPTION

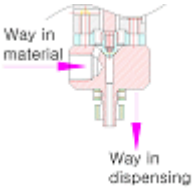
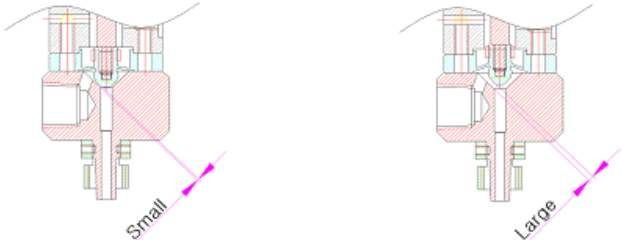

4. OPERATION PRINCIPLES

Dispensing OFF	Dispensing ON								
		<table border="1" style="width: 100%; text-align: center;"> <tr> <td style="width: 33%;">short</td> <td style="width: 33%;">Stroke</td> <td style="width: 33%;">long</td> </tr> <tr> <td>small</td> <td>Shot Volume</td> <td>large</td> </tr> </table>	short	Stroke	long	small	Shot Volume	large	
short	Stroke	long							
small	Shot Volume	large							
									
<p>In the "Normal" state (air off), the diaphragm is closed – material is not dispensed.</p>	<p>When air is applied, the diaphragm is opened and material is dispensed.</p>								
<p>Because "Air" is not entering into the driving parts, the diaphragm is closed. In this case, the material path is closed, so material is not dispensed.</p>	<p>If air is applied to the valve, the diaphragm will open. At this time material will be dispensed.</p> <p>You can increase or decrease the shot volume by adjusting the stroke (shot volume control knob).</p> <p>⚠ Notice The maximum stroke length is 0.6mm (1 rotation). There is no effect after turning the knob more than (1) rotation.</p>								

5. OPERATING PROCEDURE

5-1. Setup

►example for general installation

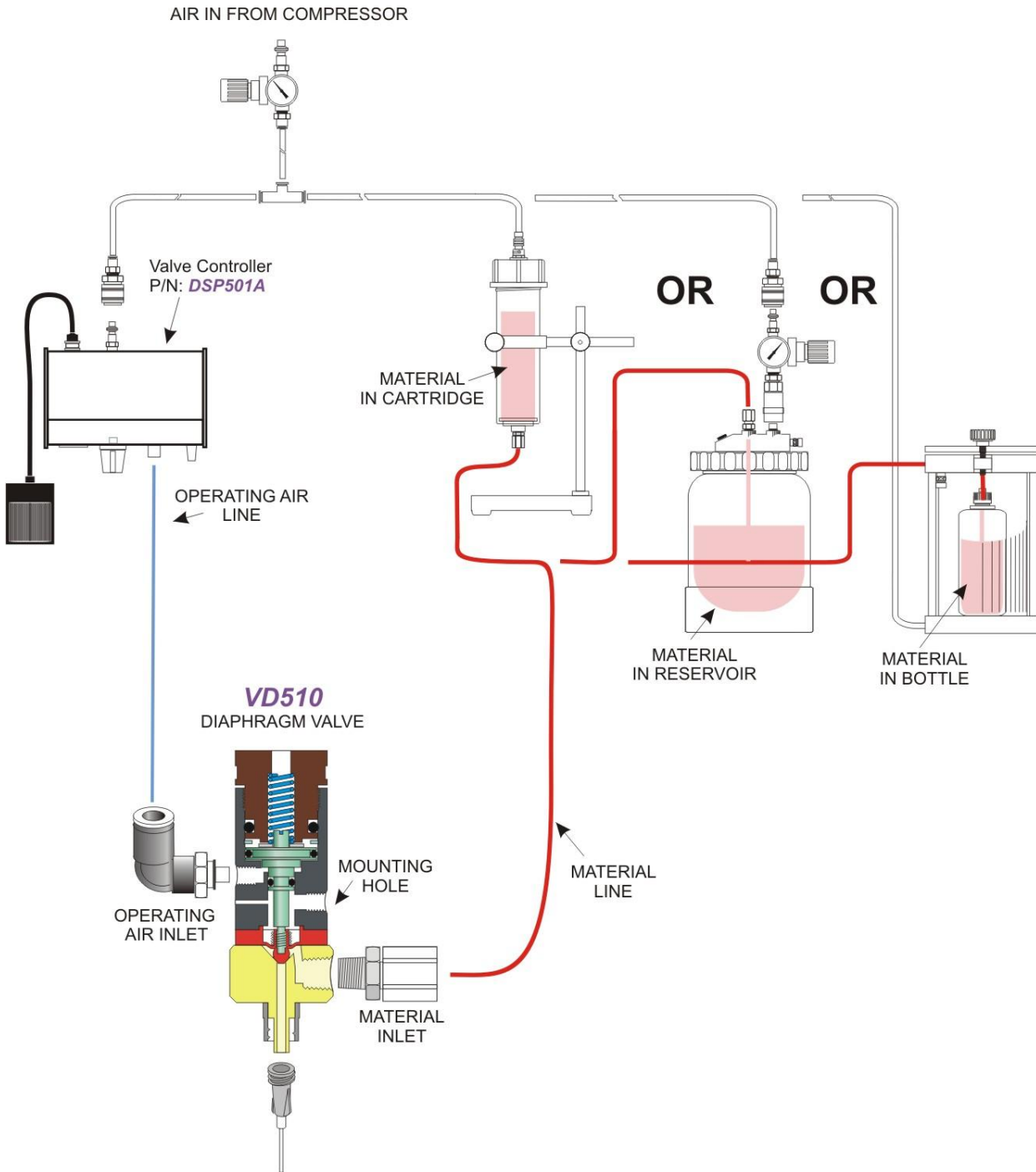

VD510-UV INSTRUCTION MANUAL

5-1-1) Fasten the valve firmly using mount hole.
(M5*P0.8*D98)

5-1-2) Connect air hose to Air In Port and Controller.

Valve driving pressure is Min 4.0kgf/cm² or more.

5-1-3) Connect fitting for material supply hose to the inner port (BSPT1/8")

 **Notice**

Do not insert fitting too deeply (7 mm or more).

5-1-4) Connect a suitable sized needle to the outer port.

5-1-5) Adjust the material pressure (max 5.0kgf/cm²).

When dispensing low viscosity materials (like water, solvent) set material pressure at 0.5kgf/cm². For

high-viscosity materials, set material pressure at 2.0kgf/cm².

Increase or decrease pressure as needed.

5-1-6)

At the time of delivery, the scale of shot volume control knob is being initiated

to point 3(½ of full stroke). Increase or decrease the number as needed.

Maximum length of stroke is 0.6 mm.

(This is corresponding to the amount when shot volume control knob makes 1 round).

 **Notice**

If you make 2 or more revolutions counterclockwise, the tensile strength of spring is weaker and the valve becomes open state all the time. In this way liquid can be dispensed.

VD510-UV INSTRUCTION MANUAL

5-1-7)

After steady mode in controller and reducing pressure of pressure container, make dispensing the liquid come out slowly.

(This is to remove bubble and dispense the first liquid from valve)

5-1-8)

Choose "timer" or "steady" mode of controller according to the state of dispensing.

5-1-9)

You can control dispensing amount by selecting 1 of following **4 options**.

▶ **4 options**

By increasing or decreasing pressure to container	Pressure increase → Dispensing amount increase
	Pressure decrease → Dispensing amount decrease
Thickness of Needle	Thick Needle → Dispensing amount increase (Improvement of tendency to pause)
	Thin Needle → Dispensing amount decrease (Worse of tendency to pause)
Flux Control Knob	Long stroke → Dispensing amount increase
	Short stroke → Dispensing amount decrease
Dispensing Time	Long dispensing time → Dispensing amount increase
	Short dispensing time → Dispensing amount decrease

*Choose the way of controlling dispensing time preferentially to get proper dispensing amount.

5-2. Maintenance

5-2-1) Washing

- ① Wash valve thoroughly after using if dispensed liquid has tendency to be stiff or has possibility to damage liquid contacting part.
- ② First of all dispense all liquid entirely from pressure container, liquid supply hose and liquid contacting part until sufficient air comes out.
- ③ Wash liquid inside of valve with a little of proper solvent.
- ④ Then wash thoroughly in order of air→solvent→air→solvent.

5-2-2) Disassembly

- ① In case of disassembly for washing or replacing part, refer to "7.Exploded View & Parts List".

- ② In case of washing valve head with sharp pin or others, try not to scratch needle or seat part. If damaged you need to replace parts because of leakage.

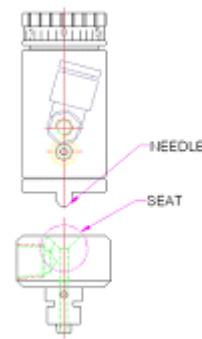

5-2-3) Assembly

① Diaphragm Assembly

- a) Loosen stroke control knob by turning twice counterclockwise.
- b) Separate valve head.
- c) Remove diaphragm by turning counterclockwise.

④Screw new diaphragm carefully to become horizontal to piston rod screw-thread.

⚠ Notice

If it isn't fit thread properly leakage may occur.

⑤After fixing diaphragm at regular intervals(0.4mm) like the picture,
for matching cylinder body and mount screw, please turn to the
location that you want using a screwdriver like next picture.

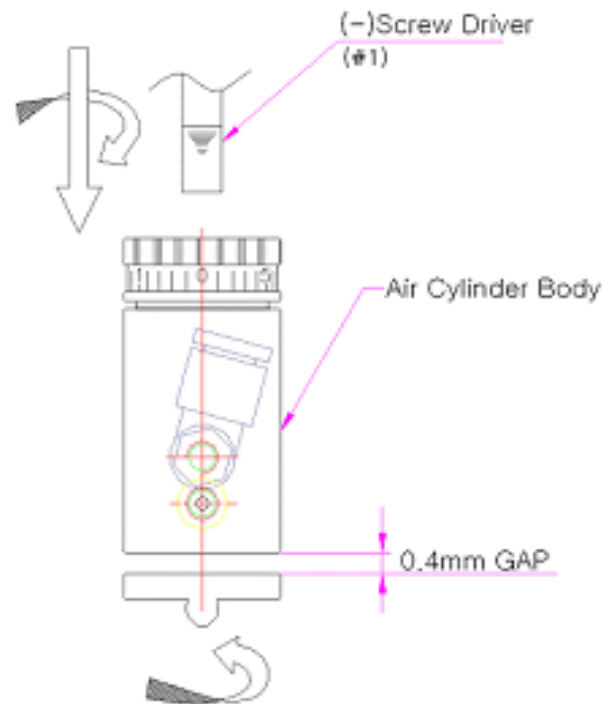

⑥To reinstall valve head fasten L(hexagon)-wrench bolt firmly.

⑦Fasten stroke control knob until it is closed.

Then open it again until stroke is appropriate.

⚠ Notice

Scale may not indicate to '0' of reference mark. In this case refer to relative scale.

(No problem to use)

6. SECTIONAL DRAWING & DIMENSIONS

► Cross-sectional View

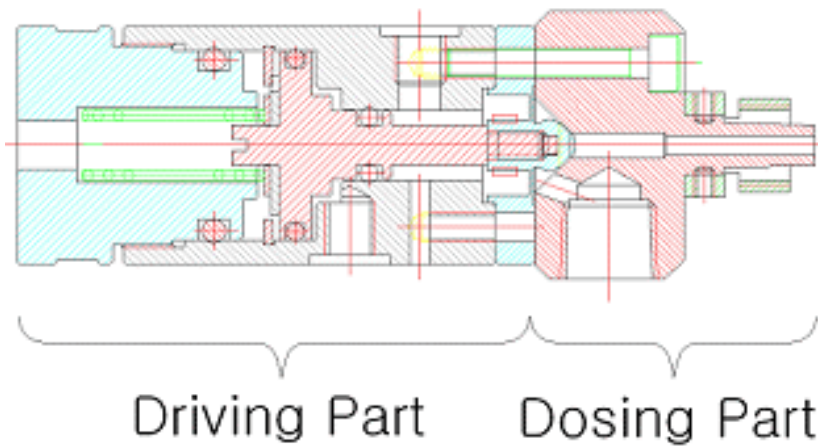

► Dimension

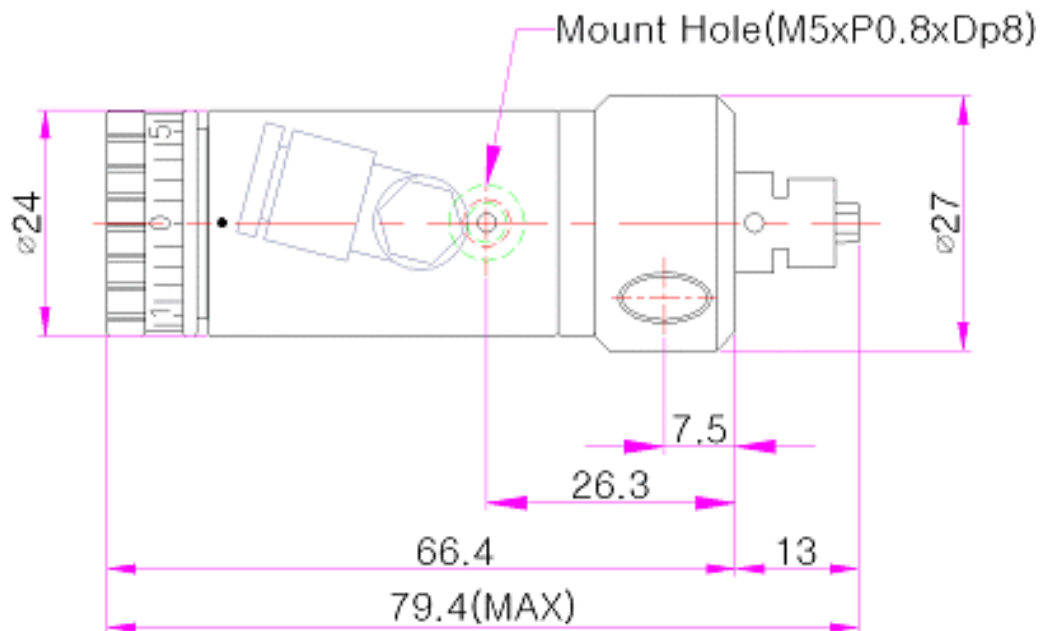

- Measurements shown in millimeters.

7. EXPLODED VIEW & PARTS LIST

► Exploded View

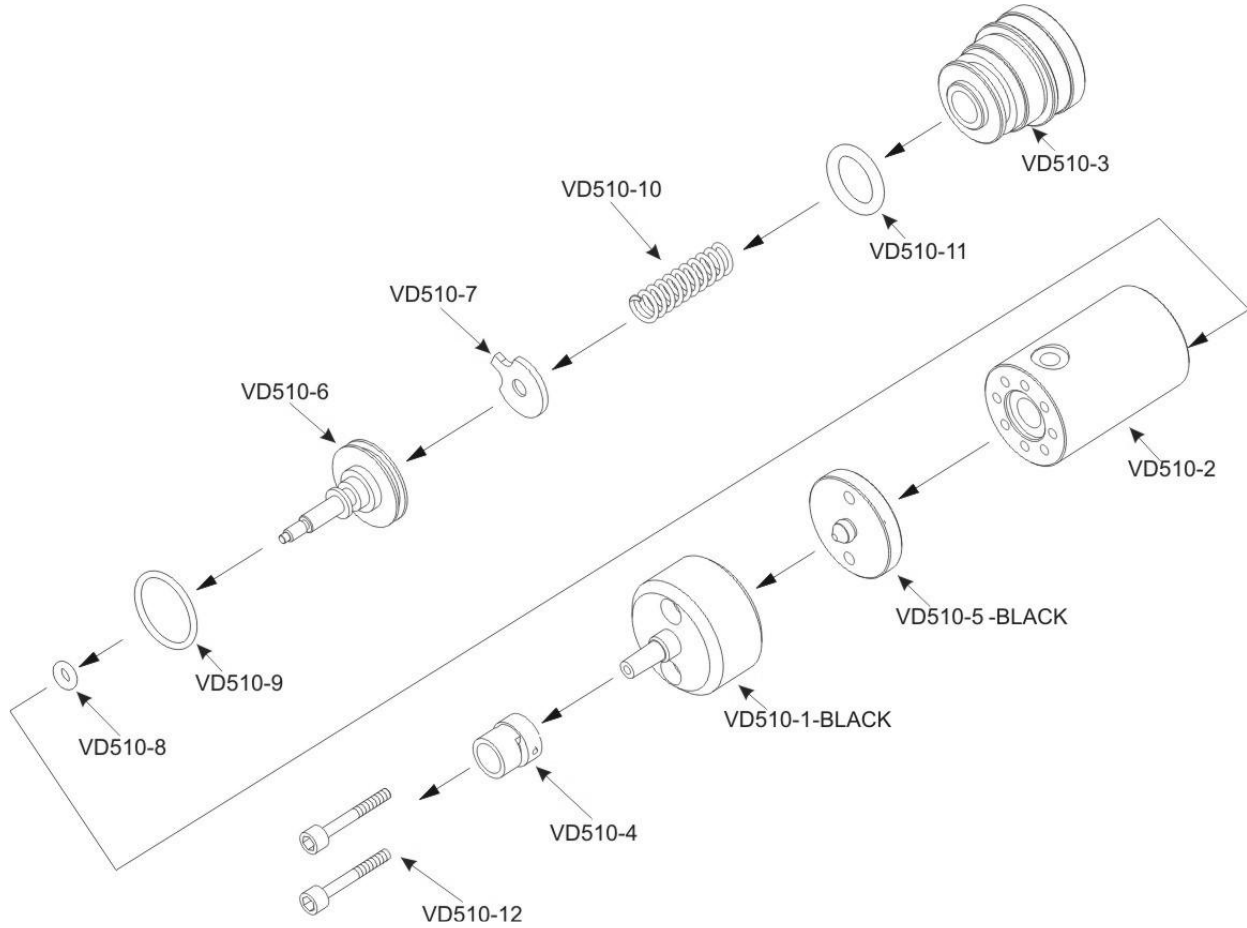

► Parts List

Part No	Description	Q'TY	Part No	Description	Q'TY
VD510-1-BLACK	CHAMBER	1	VD510-7	WASHER	1
VD510-2	CYLINDER BODY	1	VD510-8	O-RING(P4)	1
VD510-3	CYLINDER CAP	1	VD510-9	O-RING(AS016)	1
VD510-4	COLLAR	1	VD510-10	SPRING	1
VD510-5-BLACK	DIAPHRAGM	1	VD510-11	O-RING(P15)	1
VD510-6	PISTON	1	VD510-12	BOLT(M3*20)	2
			561964	FITTING	1