

DIRECTION OF ROTATION

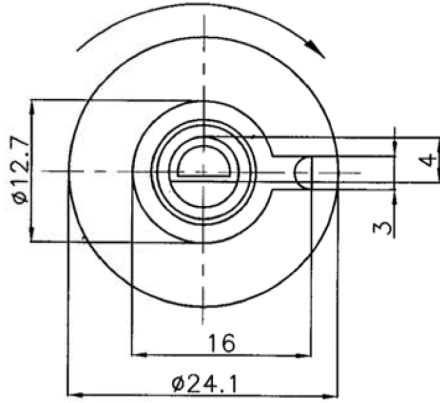

NUT 1PC

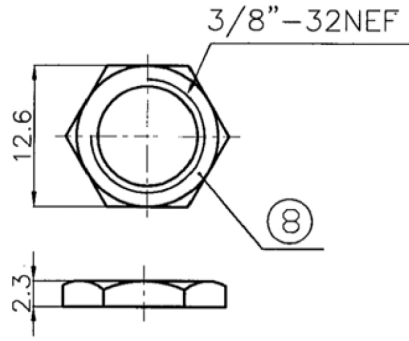

WASHER 1PC t=0.5

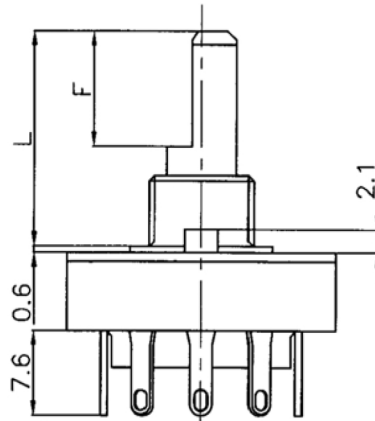
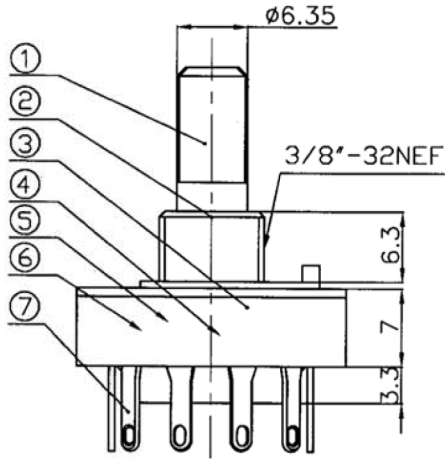
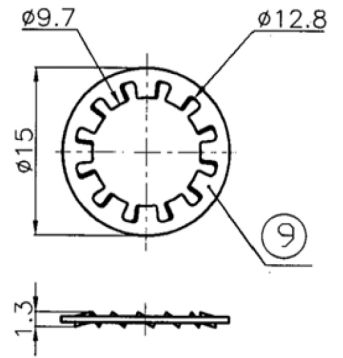

WASHER 1PCS t=1.0

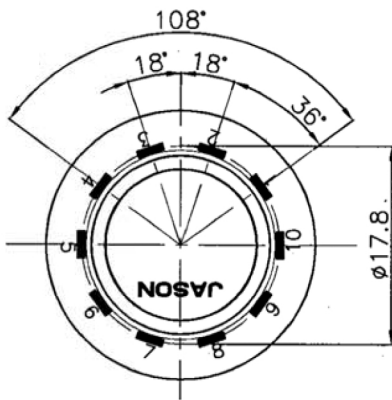
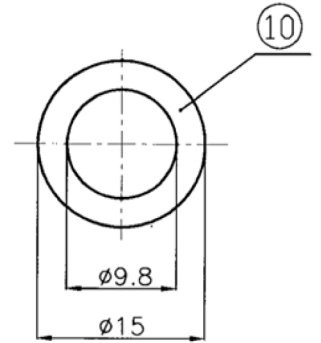

# Ninigi

SCHEMATIC

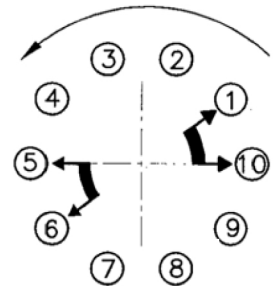

10	W-3/8"-1	Washer	1	Stell t=1.0	Zinc Plating
9	SR2634	Washer	1	Stell t=0.5	Zinc Plating
8	N-3/8"	NUT	1	Stell t=2.3	Zinc Plating
7	SR24105	Terminal Lug	10	Brass	Silver Plating
6	SR2415	Spring	1	SWPC	No Plating
5	SR2423	Bracket Plate	2	POM	No Plating
4	SR2406	Contaet Plate	2	Brass	Silver Plating
3	SR2411-5	Basic	1	PA66	No Plating
2	SR2402	Bushing	1	PA66	No Plating
1	SR2401- F	Shaft	1	PA66+15FB	No Plating

MODEL	L	F
√19.2F	19.2	10.3

N0	Part No	Description	Q'TY	Material	Finishing	MODEL	SR241-2-5-19.2F	A
TOLERANCES		DIMENSION	SCALE	DRAWING BY	CHECKED BY	APPROVED BY	DRAWING NO.	
less than	10	± 0.3	m/m	/			SR241-003	
above	10 - 30	± 0.5					Switch\SR241\Spec	
above	30 -100	± 1.0						
angular dimension		± 5 °						