



RAYSTAR

曜凌光電股份有限公司

住址: 42878 台中縣大雅鄉科雅路 25 號 5F WEB: <http://www.Raystar-Optronics.com>
5F, No.25, keya Rd. Daya Township, Taichung E-mail: sales@raystar-optronics.com
County, Taiwan Tel:886-4-2565-0761 Fax : 886-4-2565-0760

RG320240A1-BIW-V

SPECIFICATION

CUSTOMER : _____

| | |
|---|--|
| <p>APPROVED BY: (FOR CUSTOMER USE ONLY)</p> | <p>PCB VERSION: DATA:</p> |
|---|--|

| SALES BY | APPROVED BY | CHECKED BY | PREPARED BY |
|---------------------|-------------|------------|-------------|
| | | | |
| ISSUED DATE: | | | |

Contents

| | | |
|-----|--|----------------|
| 1. | <i>Specification Revision History</i> | <i>Page 3</i> |
| 2. | <i>General Specification</i> | <i>Page 4</i> |
| 3. | <i>Module Classification Information</i> | <i>Page 5</i> |
| 4. | <i>Interface Pin Function</i> | <i>Page 6</i> |
| 5. | <i>Outline dimension & Block Diagram</i> | <i>Page 7</i> |
| 6. | <i>Timing Characteristics</i> | <i>Page 8</i> |
| 7. | <i>Optical Characteristics</i> | <i>Page 11</i> |
| 8. | <i>Absolute Maximum Ratings</i> | <i>Page 12</i> |
| 9. | <i>Electrical Characteristics</i> | <i>Page 12</i> |
| 10. | <i>Backlight Information</i> | <i>Page 13</i> |
| 11. | <i>Reliability</i> | <i>Page 14</i> |
| 12. | <i>Inspection specification</i> | <i>Page 15</i> |
| 13. | <i>Precautions in use of LCD Modules</i> | <i>Page 19</i> |
| 14. | <i>Material List of Components for RoHs</i> | <i>Page 20</i> |

1. Specification Revision History

| RECORDS OF REVISION | | | |
|----------------------------|-------------|-------------------------|-------------|
| VERSION | DATE | REVISED PAGE NO. | Note |
| 1 | 2008.03.21 | | First issue |

2. General Specification

The Features of the Module is description as follow:

- Module dimension: 160.0 x 109.0 x 11.0 (max.) mm³
- View area: 122.0 x 92.0 mm²
- Active area: 115.18 x 86.38 mm²
- Number of Dots: 320 x 240
- Dot size: 0.34 x 0.34 mm²
- Dot pitch: 0.36 x 0.36 mm²
- LCD type: STN Negative, Transmissive, Blue
- View direction: 6 o'clock
- Backlight Type: LED White

3. Module Classification Information

R G 320240 A1—B I W— V
 ① ② ③ ④ ⑤ ⑥ ⑦ ⑧

| Item | Description | | |
|--------------------|---|--------------------------------|-------------------------------------|
| 1 | Brand : Raystar Optronics Inc. | | |
| 2 | Display Type | C : Character Type, | |
| | | G : Graphic Type | |
| 3 | Display Font : 320 x 240 Dots | | |
| 4 | Serials Code. | | |
| 5 | LCD Mode | P : TN Positive, Gray | |
| | | N : TN Negative, | |
| | | G : STN Positive, Gray | |
| | | Y : STN Positive, Yellow Green | |
| | | B : STN Negative, Blue | |
| | | F : FSTN Positive | |
| 6 | LCD Polarizer Type/ Temperature range/ View direction | A : Reflective, N.T, 6:00 | K : Transflective, W.T,12:00 |
| | | D : Reflective, N.T, 12:00 | 1 : Transflective, U.T,6:00 |
| | | G : Reflective, W. T, 6:00 | 4 : Transflective, U.T.12:00 |
| | | J : Reflective, W. T, 12:00 | C : Transmissive, N.T,6:00 |
| | | 0 : Reflective, U. T, 6:00 | F : Transmissive, N.T,12:00 |
| | | 3 : Reflective, U. T, 12:00 | I : Transmissive, W. T, 6:00 |
| | | B : Transflective, N.T,6:00 | L : Transmissive, W.T,12:00 |
| | | E : Transflective, N.T.12:00 | 2 : Transmissive, U. T, 6:00 |
| | | H : Transflective, W.T,6:00 | 5 : Transmissive, U.T,12:00 |
| | | 7 | Backlight Type |
| P : EL, Blue green | A : LED, Amber | | |
| T : EL, Green | W : LED, White | | |
| D : EL, White | O : LED, Orange | | |
| F : CCFL, White | G : LED, Green | | |
| 8 | Special Code | V: Built-in Negative Voltage | |

4. Interface Pin Function

| Pin No. | Symbol | Level | Description |
|---------|-----------------|------------|---|
| 1 | V _{SS} | 0V | Ground |
| 2 | V _{DD} | 5.0V | Power supply for Logic |
| 3 | V _O | (Variable) | Driving voltage for LCD |
| 4 | A0 | H/L | RD=L WR=H ,A0=L :Data Read AO=H :Status read RD=H WR=L ,A0=L :Data Write AO=H :Command write |
| 5 | WR | H/L | 8080 family: Write signal, 6800 family: R/W signal |
| 6 | RD | H/L | 8080 family: Read signal, 6800 family: Enable clock |
| 7~14 | DB0~DB7 | H/L | Data bus |
| 15 | CS | H/L | Chip select ,Active L |
| 16 | RES | H/L | Controller reset signal, Active L |
| 17 | V _{EE} | -25V | Negative voltage output (Optional) |
| 18 | NC | | No connection |
| 19 | NC | | No connection |
| 20 | NC | | No connection |

5. Outline Dimension & Block Diagram

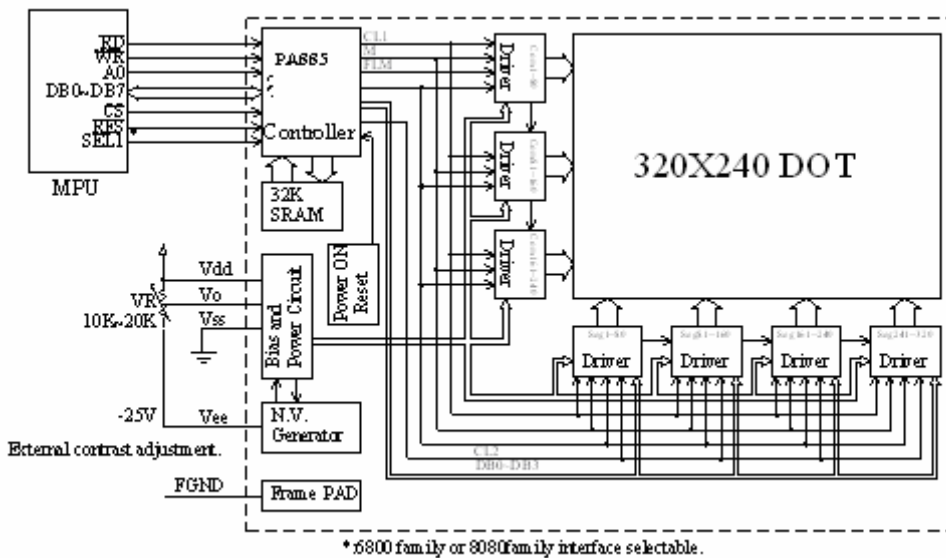
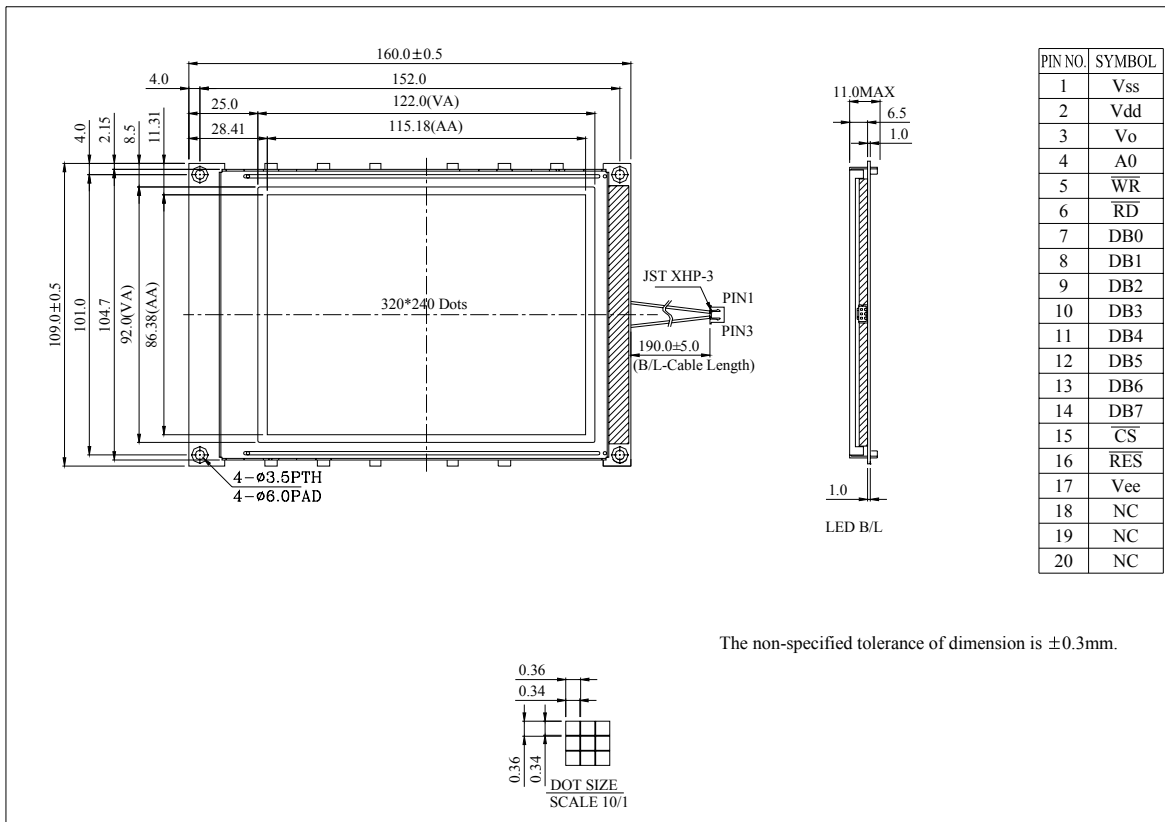

6. Timing Characteristics

The RA8835 series is controller IC that can display text and graphics on LCD panel. The RA8835 series can display layered text and graphics, scroll the display in any direction and partition the display into multiple screens. The RA8835 series stores text, character codes and bitmapped graphics data in external frame buffer memory. Display controller functions include transferring data from controlling microprocessor to the buffer memory, reading memory data, converting data to display pixels and generating timing signals for the buffer memory, LCD panel. The RA8835 series has internal character generator with 160, 5*7 pixel characters in internal mask ROM. The character generators support up to 64,8*16 pixel characters in external characters in external character generator RAM and up to 256,8*16 pixel characters in external character generator ROM .

The Command Set

Table 1. Command set

| Class | Command | Code | | | | | | | | | | | Hex | Command Description | Command Read Parameters | |
|-----------------|-------------|------|----|----|----|----|----|----|----|----|---------|---------|----------|---|-------------------------|---------|
| | | RD | WR | A0 | D7 | D6 | D5 | D4 | D3 | D2 | D1 | D0 | | | No. of Bytes | Section |
| System control | SYSTEM SET | 1 | 0 | 1 | 0 | 1 | 0 | 0 | 0 | 0 | 0 | 0 | 40 | Initialize device and display | 8 | 8.2.1 |
| | SLEEP IN | 1 | 0 | 1 | 0 | 1 | 0 | 1 | 0 | 0 | 1 | 1 | 53 | Enter standby mode | 0 | 8.2.2 |
| Display control | DISP ON/OFF | 1 | 0 | 1 | 0 | 1 | 0 | 1 | 1 | 0 | 0 | D | 58, 59 | Enable and disable display and display flashing | 1 | 8.3.1 |
| | SCROLL | 1 | 0 | 1 | 0 | 1 | 0 | 0 | 0 | 1 | 0 | 0 | 44 | Set display start address and display regions | 10 | 8.3.2 |
| | CSRFORM | 1 | 0 | 1 | 0 | 1 | 0 | 1 | 1 | 1 | 0 | 1 | 5D | Set cursor type | 2 | 8.3.3 |
| | CGRAM ADR | 1 | 0 | 1 | 0 | 1 | 0 | 1 | 1 | 1 | 0 | 0 | 5C | Set start address of character generator RAM | 2 | 8.3.6 |
| | CSRDIR | 1 | 0 | 1 | 0 | 1 | 0 | 0 | 1 | 1 | CD 1 | CD 0 | 4C to 4F | Set direction of cursor movement | 0 | 8.3.4 |
| | HDOT SCR | 1 | 0 | 1 | 0 | 1 | 0 | 1 | 1 | 0 | 1 | 0 | 5A | Set horizontal scroll position | 1 | 8.3.7 |
| | OVLAY | 1 | 0 | 1 | 0 | 1 | 0 | 1 | 1 | 0 | 1 | 1 | 5B | Set display overlay format | 1 | 8.3.5 |
| Drawing control | CSRW | 1 | 0 | 1 | 0 | 1 | 0 | 0 | 0 | 1 | 1 | 0 | 46 | Set cursor address | 2 | 8.4.1 |
| | CSRR | 1 | 0 | 1 | 0 | 1 | 0 | 0 | 0 | 1 | 1 | 1 | 47 | Read cursor address | 2 | 8.4.2 |
| Memory control | MWRITE | 1 | 0 | 1 | 0 | 1 | 0 | 0 | 0 | 0 | 1 | 0 | 42 | Write to display memory | — | 8.5.1 |
| | MREAD | 1 | 0 | 1 | 0 | 1 | 0 | 0 | 0 | 0 | 1 | 1 | 43 | Read from display memory | — | 8.5.2 |

Notes:

- In general, the internal registers of the RA8835 series are modified as each command parameter is input. However, the microprocessor does not have to set all the parameters of a command and may send a new command before all parameters have been input. The internal registers for the parameters that have been input will have been changed but the remaining parameter registers are unchanged.
 - 2-byte parameters (where two bytes are treated as 1 data item) are handled as follows:
 - CSRW, CSRR: Each byte is processed individually. The microprocessor may read or write just the low byte of the cursor address.
 - SYSTEM SET, SCROLL, CGRAMADR: Both parameter bytes are processed together. If the command is changed after half of the parameter has been input, the single byte is ignored.
- APL and APH are 2-byte parameters, but are treated as two 1-byte parameters.

SYSTEM SET

Initializes the device, sets the window sizes, and selects the LCD interface format. Since this command sets the basic operating parameters of the RA8835 i series, an

incorrect SYSTEM SET command may cause other commands to operate incorrectly.

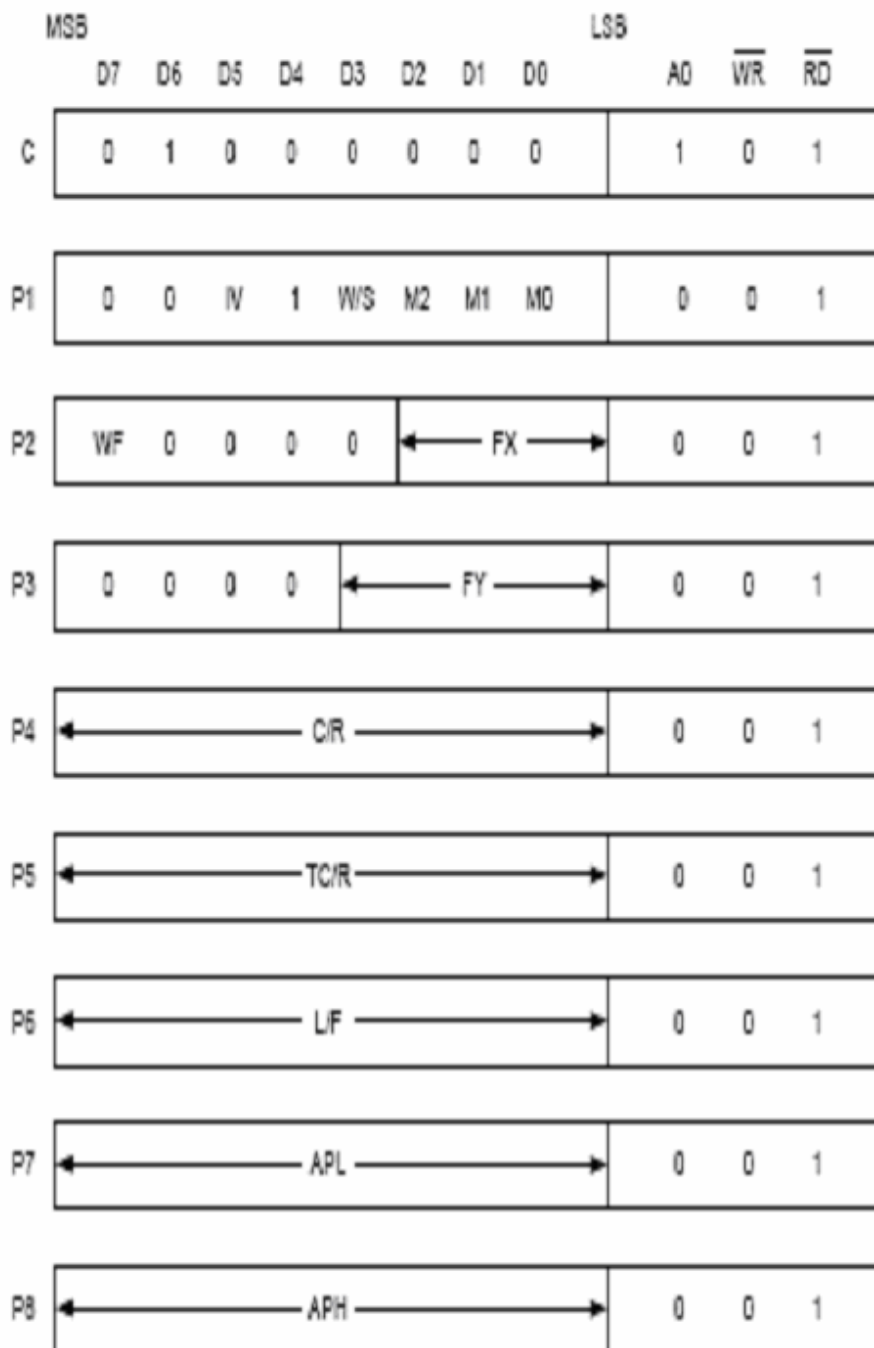

Figure 1. SYSTEM SET instruction

7. Optical Characteristics

| ITEM | SYMBOL | CONDITION | MIN | TYP | MAX | UNIT |
|----------------|---------------|-------------|-----|-----|-----|------|
| View Angle | (V) θ | $CR \geq 2$ | 20 | — | 40 | deg. |
| | (H) φ | $CR \geq 2$ | -30 | — | 30 | deg. |
| Contrast Ratio | CR | — | — | 3 | — | — |
| Response Time | T rise | — | — | 200 | 300 | ms |
| | T fall | — | — | 150 | 200 | ms |

7.1 Definitions

■ View Angles

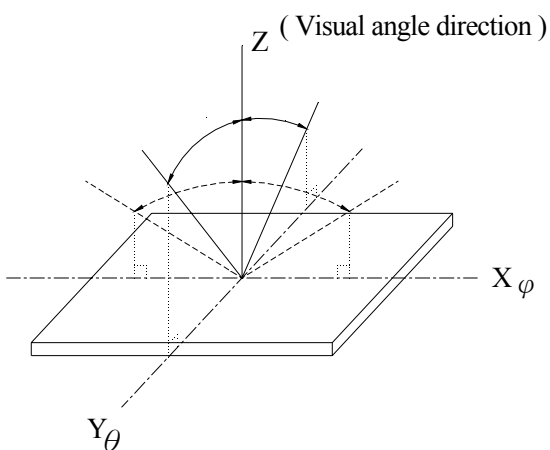

■ Contrast Ratio

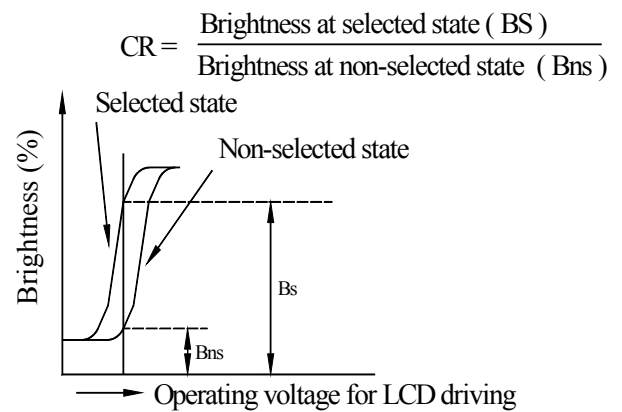

■ Response Time

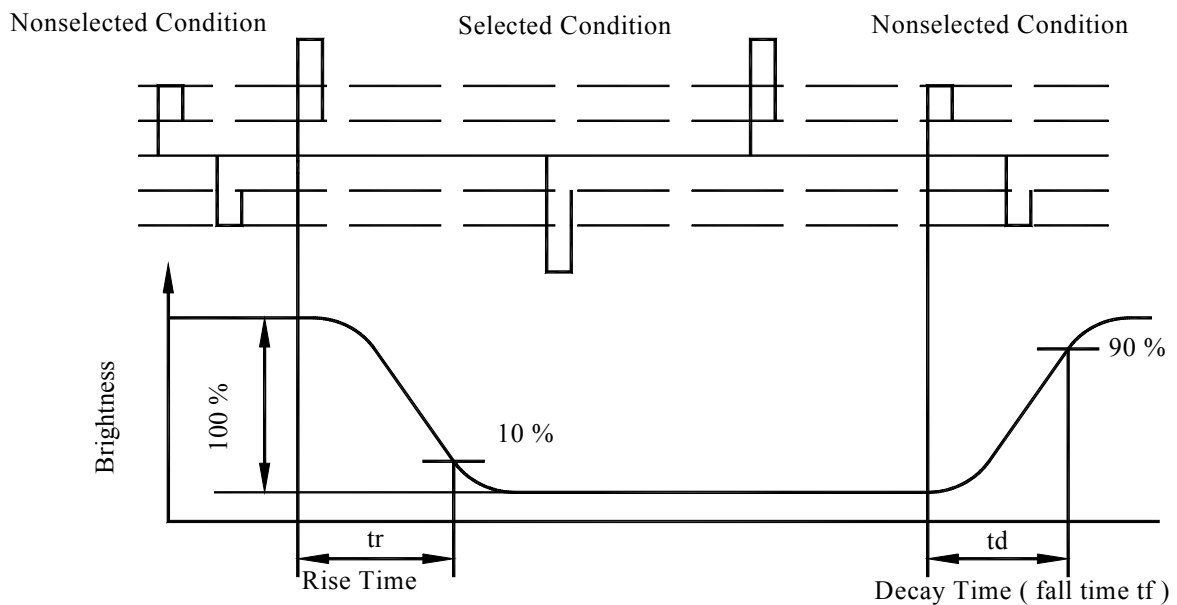

8. Absolute Maximum Ratings

| ITEM | SYMBOL | MIN. | TYP. | MAX. | UNIT |
|--------------------------|----------------------------------|------|------|-----------------|------|
| Operating Temperature | T _{OP} | -20 | — | +70 | °C |
| Storage Temperature | T _{ST} | -30 | — | +80 | °C |
| Input Voltage | V _I | 0 | — | V _{DD} | V |
| Supply Voltage For Logic | V _{DD} | 0 | — | 6.5 | V |
| Supply Voltage For LCD | V _{DD} -V _{EE} | 0 | — | 32 | V |

9. Electrical Characteristics

| ITEM | SYMBOL | CONDITION | MIN. | TYP. | MAX. | UNIT |
|------------------------|----------------------------------|-----------|--------------------|-------|--------------------|------|
| Logic Voltage | V _{DD} -V _{SS} | — | 4.5 | 5.0 | 5.5 | V |
| Supply Voltage For LCD | V _{DD} -V _O | Ta=-20°C | — | — | 26.5 | V |
| | | Ta=25°C | — | 24.0 | — | V |
| | | Ta=+70°C | 22.1 | — | — | V |
| Input High Volt. | V _{IH} | — | 0.5V _{DD} | — | V _{DD} | V |
| Input Low Volt. | V _{IL} | — | V _{SS} | — | 0.2V _{DD} | V |
| Output High Volt. | V _{OH} | — | 2.4 | — | — | V |
| Output Low Volt. | V _{OL} | — | — | — | 0.4 | V |
| Supply Current | I _{DD} | — | 95.0 | 100.0 | 110.0 | mA |

10. Backlight Information

Specification

(Ta=25°C)

| PARAMETER | SYMBOL | MIN | TYP | MAX | UNIT | TEST CONDITION |
|--------------------|------------------|-------|-----|-----|-------------------|--------------------------|
| Supply Current | I _{LED} | 115.2 | 128 | 200 | mA | V=3.5V |
| Supply Voltage | V | 3.4 | 3.5 | 3.6 | V | — |
| Reverse Voltage | V _R | — | — | 5 | V | — |
| Luminous Intensity | I _V | 260 | 280 | — | CD/M ² | I _{LED} =128mA |
| Wave Length | λ _p | — | — | — | nm | I _{LED} =128mA |
| Life Time | — | — | 50K | — | Hr. | I _{LED} ≤ 128mA |
| Color | White | | | | | |

Note: The LED of B/L is drive by current only, drive voltage is for reference only. drive voltage can make driving current under safety area (current between minimum and maximum).

LED B\L Drive Method

1. Drive from A , K

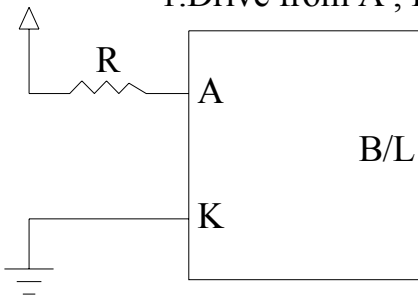

11. Reliability

Content of Reliability Test (wide temperature, -20°C~70°C)

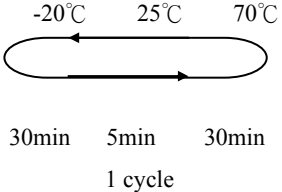
| Environmental Test | | | |
|---|--|--|------|
| Test Item | Content of Test | Test Condition | Note |
| High Temperature storage | Endurance test applying the high storage temperature for a long time. | 80°C 200hrs | 2 |
| Low Temperature storage | Endurance test applying the high storage temperature for a long time. | -30°C 200hrs | 1,2 |
| High Temperature Operation | Endurance test applying the electric stress (Voltage & Current) and the thermal stress to the element for a long time. | 70°C 200hrs | — |
| Low Temperature Operation | Endurance test applying the electric stress under low temperature for a long time. | -20°C 200hrs | 1 |
| High Temperature/ Humidity Operation | The module should be allowed to stand at 60°C,90%RH max For 96hrs under no-load condition excluding the polarizer, Then taking it out and drying it at normal temperature. | 60°C,90%RH 96hrs | 1,2 |
| Thermal shock resistance | The sample should be allowed stand the following 10 cycles of operation  | -20°C/70°C 10 cycles | — |
| Vibration test | Endurance test applying the vibration during transportation and using. | Total fixed amplitude : 15mm Vibration Frequency : 10~55Hz One cycle 60 seconds to 3 directions of X,Y,Z for Each 15 minutes | 3 |
| Static electricity test | Endurance test applying the electric stress to the terminal. | VS=800V,RS=1.5kΩ CS=100pF 1 time | — |

Note1: No dew condensation to be observed.

Note2: The function test shall be conducted after 4 hours storage at the normal Temperature and humidity after remove from the test chamber.

Note3: Vibration test will be conducted to the product itself without putting it in a container.

12. Inspection specification

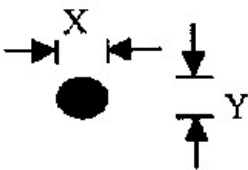
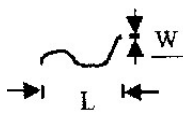
| NO | Item | Criterion | AQL | | | | | | | | | | | | |
|--|---|--|-----------------|-----------------|------------------|-----------------|-------------------------|----------------------|-------------------------|--------------|----------------------|-----|------------|---------------|-----|
| 01 | Electrical Testing | 1.1 Missing vertical, horizontal segment, segment contrast defect. 1.2 Missing character , dot or icon. 1.3 Display malfunction. 1.4 No function or no display. 1.5 Current consumption exceeds product specifications. 1.6 LCD viewing angle defect. 1.7 Mixed product types. 1.8 Contrast defect. | 0.65 | | | | | | | | | | | | |
| 02 | Black or white spots on LCD (display only) | 2.1 White and black spots on display $\leq 0.25\text{mm}$, no more than three white or black spots present. 2.2 Densely spaced: No more than two spots or lines within 3mm | 2.5 | | | | | | | | | | | | |
| 03 | LCD black spots, white spots, contamination (non-display) | 3.1 Round type : As following drawing $\Phi = (x + y) / 2$  <table border="1" data-bbox="874 940 1353 1187"> <thead> <tr> <th>SIZE</th> <th>Acceptable Q TY</th> </tr> </thead> <tbody> <tr> <td>$\Phi \leq 0.10$</td> <td>Accept no dense</td> </tr> <tr> <td>$0.10 < \Phi \leq 0.20$</td> <td>2</td> </tr> <tr> <td>$0.20 < \Phi \leq 0.25$</td> <td>1</td> </tr> <tr> <td>$0.25 < \Phi$</td> <td>0</td> </tr> </tbody> </table> | SIZE | Acceptable Q TY | $\Phi \leq 0.10$ | Accept no dense | $0.10 < \Phi \leq 0.20$ | 2 | $0.20 < \Phi \leq 0.25$ | 1 | $0.25 < \Phi$ | 0 | 2.5 | | |
| | | SIZE | Acceptable Q TY | | | | | | | | | | | | |
| $\Phi \leq 0.10$ | Accept no dense | | | | | | | | | | | | | | |
| $0.10 < \Phi \leq 0.20$ | 2 | | | | | | | | | | | | | | |
| $0.20 < \Phi \leq 0.25$ | 1 | | | | | | | | | | | | | | |
| $0.25 < \Phi$ | 0 | | | | | | | | | | | | | | |
| 3.2 Line type : (As following drawing)  <table border="1" data-bbox="710 1249 1353 1460"> <thead> <tr> <th>Length</th> <th>Width</th> <th>Acceptable Q TY</th> </tr> </thead> <tbody> <tr> <td>---</td> <td>$W \leq 0.02$</td> <td>Accept no dense</td> </tr> <tr> <td>$L \leq 3.0$</td> <td>$0.02 < W \leq 0.03$</td> <td rowspan="2">2</td> </tr> <tr> <td>$L \leq 2.5$</td> <td>$0.03 < W \leq 0.05$</td> </tr> <tr> <td>---</td> <td>$0.05 < W$</td> <td>As round type</td> </tr> </tbody> </table> | Length | Width | Acceptable Q TY | --- | $W \leq 0.02$ | Accept no dense | $L \leq 3.0$ | $0.02 < W \leq 0.03$ | 2 | $L \leq 2.5$ | $0.03 < W \leq 0.05$ | --- | $0.05 < W$ | As round type | 2.5 |
| Length | Width | Acceptable Q TY | | | | | | | | | | | | | |
| --- | $W \leq 0.02$ | Accept no dense | | | | | | | | | | | | | |
| $L \leq 3.0$ | $0.02 < W \leq 0.03$ | 2 | | | | | | | | | | | | | |
| $L \leq 2.5$ | $0.03 < W \leq 0.05$ | | | | | | | | | | | | | | |
| --- | $0.05 < W$ | As round type | | | | | | | | | | | | | |
| 04 | Polarizer bubbles | If bubbles are visible, judge using black spot specifications, not easy to find, must check in specify direction. <table border="1" data-bbox="842 1657 1353 1904"> <thead> <tr> <th>Size Φ</th> <th>Acceptable Q TY</th> </tr> </thead> <tbody> <tr> <td>$\Phi \leq 0.20$</td> <td>Accept no dense</td> </tr> <tr> <td>$0.20 < \Phi \leq 0.50$</td> <td>3</td> </tr> <tr> <td>$0.50 < \Phi \leq 1.00$</td> <td>2</td> </tr> <tr> <td>$1.00 < \Phi$</td> <td>0</td> </tr> <tr> <td>Total Q TY</td> <td>3</td> </tr> </tbody> </table> | Size Φ | Acceptable Q TY | $\Phi \leq 0.20$ | Accept no dense | $0.20 < \Phi \leq 0.50$ | 3 | $0.50 < \Phi \leq 1.00$ | 2 | $1.00 < \Phi$ | 0 | Total Q TY | 3 | 2.5 |
| Size Φ | Acceptable Q TY | | | | | | | | | | | | | | |
| $\Phi \leq 0.20$ | Accept no dense | | | | | | | | | | | | | | |
| $0.20 < \Phi \leq 0.50$ | 3 | | | | | | | | | | | | | | |
| $0.50 < \Phi \leq 1.00$ | 2 | | | | | | | | | | | | | | |
| $1.00 < \Phi$ | 0 | | | | | | | | | | | | | | |
| Total Q TY | 3 | | | | | | | | | | | | | | |

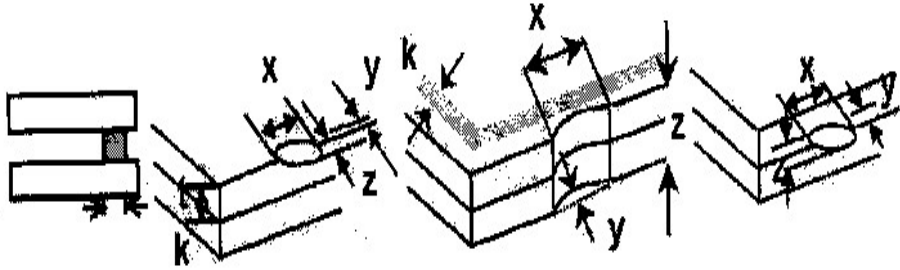
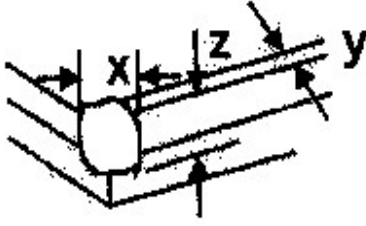
| NO | Item | Criterion | AQL | | | | | | | | | | | | | | | | | | |
|--------------------|-----------------------|---|-------------------|---------------|----------------|---------------|-----------------------|---------------|--------------------|-------------------|---------------|-------------------|---------------|----------------|---------------|-----------------------|---------------|--------------------|-------------------|---------------|-----|
| 05 | Scratches | Follow NO.3 LCD black spots, white spots, contamination | | | | | | | | | | | | | | | | | | | |
| 06 | Chipped glass | <p>Symbols Define: x: Chip length y: Chip width z: Chip thickness k: Seal width t: Glass thickness a: LCD side length L: Electrode pad length:</p> <p>6.1 General glass chip : 6.1.1 Chip on panel surface and crack between panels:</p>  <table border="1" data-bbox="443 1034 1353 1191"> <thead> <tr> <th>z: Chip thickness</th> <th>y: Chip width</th> <th>x: Chip length</th> </tr> </thead> <tbody> <tr> <td>$Z \leq 1/2t$</td> <td>Not over viewing area</td> <td>$x \leq 1/8a$</td> </tr> <tr> <td>$1/2t < z \leq 2t$</td> <td>Not exceed $1/3k$</td> <td>$x \leq 1/8a$</td> </tr> </tbody> </table> <p>⊙ If there are 2 or more chips, x is total length of each chip.</p> <p>6.1.2 Corner crack:</p>  <table border="1" data-bbox="443 1568 1353 1724"> <thead> <tr> <th>z: Chip thickness</th> <th>y: Chip width</th> <th>x: Chip length</th> </tr> </thead> <tbody> <tr> <td>$Z \leq 1/2t$</td> <td>Not over viewing area</td> <td>$x \leq 1/8a$</td> </tr> <tr> <td>$1/2t < z \leq 2t$</td> <td>Not exceed $1/3k$</td> <td>$x \leq 1/8a$</td> </tr> </tbody> </table> <p>⊙ If there are 2 or more chips, x is the total length of each chip.</p> | z: Chip thickness | y: Chip width | x: Chip length | $Z \leq 1/2t$ | Not over viewing area | $x \leq 1/8a$ | $1/2t < z \leq 2t$ | Not exceed $1/3k$ | $x \leq 1/8a$ | z: Chip thickness | y: Chip width | x: Chip length | $Z \leq 1/2t$ | Not over viewing area | $x \leq 1/8a$ | $1/2t < z \leq 2t$ | Not exceed $1/3k$ | $x \leq 1/8a$ | 2.5 |
| z: Chip thickness | y: Chip width | x: Chip length | | | | | | | | | | | | | | | | | | | |
| $Z \leq 1/2t$ | Not over viewing area | $x \leq 1/8a$ | | | | | | | | | | | | | | | | | | | |
| $1/2t < z \leq 2t$ | Not exceed $1/3k$ | $x \leq 1/8a$ | | | | | | | | | | | | | | | | | | | |
| z: Chip thickness | y: Chip width | x: Chip length | | | | | | | | | | | | | | | | | | | |
| $Z \leq 1/2t$ | Not over viewing area | $x \leq 1/8a$ | | | | | | | | | | | | | | | | | | | |
| $1/2t < z \leq 2t$ | Not exceed $1/3k$ | $x \leq 1/8a$ | | | | | | | | | | | | | | | | | | | |

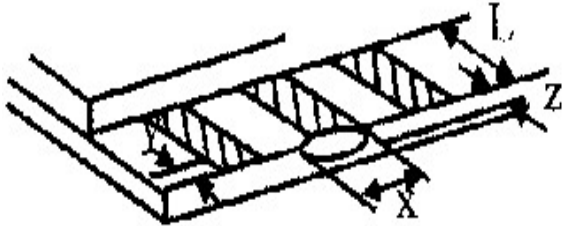
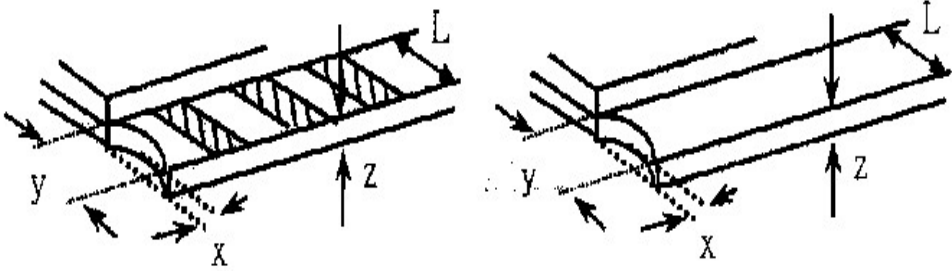
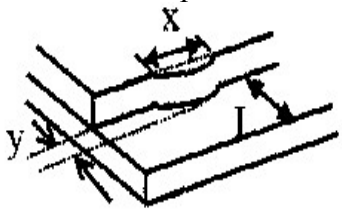
| NO | Item | Criterion | AQL | | | | | | | | | | | | | | | | |
|-----------------------|----------------|--|---------------|----------------|-------------------|-----------------------|---------------|----------------|---------------|----------------|-------------------|------------|---------------|----------------|----------|-----------|---------------|------------|-----|
| 06 | Glass crack | <p>Symbols :</p> <p>x: Chip length y: Chip width z: Chip thickness k: Seal width t: Glass thickness a: LCD side length L: Electrode pad length</p> <p>6.2 Protrusion over terminal :</p> <p>6.2.1 Chip on electrode pad :</p>  <table border="1" data-bbox="338 869 1249 952"> <tr> <td>y: Chip width</td> <td>x: Chip length</td> <td>z: Chip thickness</td> </tr> <tr> <td>$y \leq 0.5\text{mm}$</td> <td>$x \leq 1/8a$</td> <td>$0 < z \leq t$</td> </tr> </table> <p>6.2.2 Non-conductive portion:</p>  <table border="1" data-bbox="408 1279 1249 1361"> <tr> <td>y: Chip width</td> <td>x: Chip length</td> <td>z: Chip thickness</td> </tr> <tr> <td>$y \leq L$</td> <td>$x \leq 1/8a$</td> <td>$0 < z \leq t$</td> </tr> </table> <ul style="list-style-type: none"> ⊙ If the chipped area touches the ITO terminal, over 2/3 of the ITO must remain and be inspected according to electrode terminal specifications. ⊙ If the product will be heat sealed by the customer, the alignment mark not be damaged. <p>6.2.3 Substrate protuberance and internal crack.</p>  <table border="1" data-bbox="746 1608 1257 1691"> <tr> <td>y: width</td> <td>x: length</td> </tr> <tr> <td>$y \leq 1/3L$</td> <td>$x \leq a$</td> </tr> </table> | y: Chip width | x: Chip length | z: Chip thickness | $y \leq 0.5\text{mm}$ | $x \leq 1/8a$ | $0 < z \leq t$ | y: Chip width | x: Chip length | z: Chip thickness | $y \leq L$ | $x \leq 1/8a$ | $0 < z \leq t$ | y: width | x: length | $y \leq 1/3L$ | $x \leq a$ | 2.5 |
| y: Chip width | x: Chip length | z: Chip thickness | | | | | | | | | | | | | | | | | |
| $y \leq 0.5\text{mm}$ | $x \leq 1/8a$ | $0 < z \leq t$ | | | | | | | | | | | | | | | | | |
| y: Chip width | x: Chip length | z: Chip thickness | | | | | | | | | | | | | | | | | |
| $y \leq L$ | $x \leq 1/8a$ | $0 < z \leq t$ | | | | | | | | | | | | | | | | | |
| y: width | x: length | | | | | | | | | | | | | | | | | | |
| $y \leq 1/3L$ | $x \leq a$ | | | | | | | | | | | | | | | | | | |

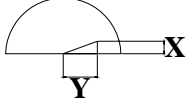
| NO | Item | Criterion | AQL |
|----|--------------------|--|---|
| 07 | Cracked glass | The LCD with extensive crack is not acceptable. | 2.5 |
| 08 | Backlight elements | 8.1 Illumination source flickers when lit. 8.2 Spots or scratched that appear when lit must be judged. Using LCD spot, lines and contamination standards. 8.3 Backlight doesn't light or color wrong. | 0.65 2.5 0.65 |
| 09 | Bezel | 9.1 Bezel may not have rust, be deformed or have fingerprints, stains or other contamination. 9.2 Bezel must comply with job specifications. | 2.5 0.65 |
| 10 | PCB 、 COB | 10.1 COB seal may not have pinholes larger than 0.2mm or contamination. 10.2 COB seal surface may not have pinholes through to the IC. 10.3 The height of the COB should not exceed the height indicated in the assembly diagram. 10.4 There may not be more than 2mm of sealant outside the seal area on the PCB. And there should be no more than three places. 10.5 No oxidation or contamination PCB terminals. 10.6 Parts on PCB must be the same as on the production characteristic chart. There should be no wrong parts, missing parts or excess parts. 10.7 The jumper on the PCB should conform to the product characteristic chart. 10.8 If solder gets on bezel tab pads, LED pad, zebra pad or screw hold pad, make sure it is smoothed down. 10.9 The Scraping testing standard for Copper Coating of PCB  $X * Y \leq 2\text{mm}^2$ | 2.5 2.5 0.65 2.5 0.65 0.65 2.5 2.5 |
| 11 | Soldering | 11.1 No un-melted solder paste may be present on the PCB. 11.2 No cold solder joints, missing solder connections, oxidation or icicle. 11.3 No residue or solder balls on PCB. 11.4 No short circuits in components on PCB. | 2.5 2.5 2.5 0.65 |

| NO | Item | Criterion | AQL |
|----|--------------------|---|------|
| 12 | General appearance | 12.1 No oxidation, contamination, curves or, bends on interface Pin (OLB) of TCP. | 2.5 |
| | | 12.2 No cracks on interface pin (OLB) of TCP. | 0.65 |
| | | 12.3 No contamination, solder residue or solder balls on product. | 2.5 |
| | | 12.4 The IC on the TCP may not be damaged, circuits. | 2.5 |
| | | 12.5 The uppermost edge of the protective strip on the interface pin must be present or look as if it cause the interface pin to sever. | 2.5 |
| | | 12.6 The residual rosin or tin oil of soldering (component or chip component) is not burned into brown or black color. | 2.5 |
| | | 12.7 Sealant on top of the ITO circuit has not hardened. | 2.5 |
| | | 12.8 Pin type must match type in specification sheet. | 0.65 |
| | | 12.9 LCD pin loose or missing pins. | 0.65 |
| | | 12.10 Product packaging must the same as specified on packaging specification sheet. | 0.65 |
| | | 12.11 Product dimension and structure must conform to product specification sheet. | 0.65 |

13. Precautions in use of LCD Modules

- (1) Avoid applying excessive shocks to the module or making any alterations or modifications to it.
- (2) Don't make extra holes on the printed circuit board, modify its shape or change the components of LCD module.
- (3) Don't disassemble the LCM.
- (4) Don't operate it above the absolute maximum rating.
- (5) Don't drop, bend or twist LCM.
- (6) Soldering: only to the I/O terminals.
- (7) Storage: please storage in anti-static electricity container and clean environment.

14. Material List of Components for RoHs

1. RAYSTAR Optronics Co., Ltd. hereby declares that all of or part of products, including, but not limited to, the LCM, accessories or packages, manufactured and/or delivered to your company (including your subsidiaries and affiliated company) directly or indirectly by our company (including our subsidiaries or affiliated companies) do not intentionally contain any of the substances listed in all applicable EU directives and regulations, including the following substances.

Exhibit A : The Harmful Material List

| Material | (Cd) | (Pb) | (Hg) | (Cr6+) | PBBs | PBDEs |
|--|---------|----------|----------|----------|----------|----------|
| Limited Value | 100 ppm | 1000 ppm | 1000 ppm | 1000 ppm | 1000 ppm | 1000 ppm |
| Above limited value is set up according to RoHS. | | | | | | |

2. Process for RoHS requirement :

- (1) Use the Sn/Ag/Cu soldering surface ; the surface of Pb-free solder is rougher than we used before.
- (2) Heat-resistance temp. :
 Reflow : 250°C ,30 seconds Max. ;
 Connector soldering wave or hand soldering : 320°C , 10 seconds max.
- (3) Temp. curve of reflow, max. Temp. : 235±5°C ;
 Recommended customer's soldering temp. of connector : 280°C , 3 seconds.

LCM Sample Estimate Feedback Sheet

Module Number : _____

1、Panel Specification :

| | | |
|----------------------------|-------------------------------|-------------------------------------|
| 1. Panel Type : | <input type="checkbox"/> Pass | <input type="checkbox"/> NG , _____ |
| 2. View Direction : | <input type="checkbox"/> Pass | <input type="checkbox"/> NG , _____ |
| 3. Numbers of Dots : | <input type="checkbox"/> Pass | <input type="checkbox"/> NG , _____ |
| 4. View Area : | <input type="checkbox"/> Pass | <input type="checkbox"/> NG , _____ |
| 5. Active Area : | <input type="checkbox"/> Pass | <input type="checkbox"/> NG , _____ |
| 6. Operating Temperature : | <input type="checkbox"/> Pass | <input type="checkbox"/> NG , _____ |
| 7. Storage Temperature : | <input type="checkbox"/> Pass | <input type="checkbox"/> NG , _____ |
| 8. Others : | _____ | |

2、Mechanical Specification :

| | | |
|-----------------------------|-------------------------------|-------------------------------------|
| 1. PCB Size : | <input type="checkbox"/> Pass | <input type="checkbox"/> NG , _____ |
| 2. Frame Size : | <input type="checkbox"/> Pass | <input type="checkbox"/> NG , _____ |
| 3. Material of Frame : | <input type="checkbox"/> Pass | <input type="checkbox"/> NG , _____ |
| 4. Connector Position : | <input type="checkbox"/> Pass | <input type="checkbox"/> NG , _____ |
| 5. Fix Hole Position : | <input type="checkbox"/> Pass | <input type="checkbox"/> NG , _____ |
| 6. Backlight Position : | <input type="checkbox"/> Pass | <input type="checkbox"/> NG , _____ |
| 7. Thickness of PCB : | <input type="checkbox"/> Pass | <input type="checkbox"/> NG , _____ |
| 8. Height of Frame to PCB : | <input type="checkbox"/> Pass | <input type="checkbox"/> NG , _____ |
| 9. Height of Module : | <input type="checkbox"/> Pass | <input type="checkbox"/> NG , _____ |
| 10. Others : | <input type="checkbox"/> Pass | <input type="checkbox"/> NG , _____ |

3、Relative Hole Size :

| | | |
|-----------------------------|-------------------------------|-------------------------------------|
| 1. Pitch of Connector : | <input type="checkbox"/> Pass | <input type="checkbox"/> NG , _____ |
| 2. Hole size of Connector : | <input type="checkbox"/> Pass | <input type="checkbox"/> NG , _____ |
| 3. Mounting Hole size : | <input type="checkbox"/> Pass | <input type="checkbox"/> NG , _____ |
| 4. Mounting Hole Type : | <input type="checkbox"/> Pass | <input type="checkbox"/> NG , _____ |
| 5. Others : | <input type="checkbox"/> Pass | <input type="checkbox"/> NG , _____ |

4、Backlight Specification :

| | | |
|---|-------------------------------|-------------------------------------|
| 1. B/L Type : | <input type="checkbox"/> Pass | <input type="checkbox"/> NG , _____ |
| 2. B/L Color : | <input type="checkbox"/> Pass | <input type="checkbox"/> NG , _____ |
| 3. B/L Driving Voltage (Reference for LED Type) : | <input type="checkbox"/> Pass | <input type="checkbox"/> NG , _____ |
| 4. B/L Driving Current : | <input type="checkbox"/> Pass | <input type="checkbox"/> NG , _____ |
| 5. Brightness of B/L : | <input type="checkbox"/> Pass | <input type="checkbox"/> NG , _____ |
| 6. B/L Solder Method : | <input type="checkbox"/> Pass | <input type="checkbox"/> NG , _____ |
| 7. Others : | <input type="checkbox"/> Pass | <input type="checkbox"/> NG , _____ |

>> Go to page 2 <<

| | | |
|--|-------------------------------|-------------------------------------|
| Module Number : _____ | | |
| 5 、 <u>Electronic Characteristics of Module</u> : | | |
| 1.Input Voltage : | <input type="checkbox"/> Pass | <input type="checkbox"/> NG , _____ |
| 2.Supply Current : | <input type="checkbox"/> Pass | <input type="checkbox"/> NG , _____ |
| 3.Driving Voltage for LCD : | <input type="checkbox"/> Pass | <input type="checkbox"/> NG , _____ |
| 4.Contrast for LCD : | <input type="checkbox"/> Pass | <input type="checkbox"/> NG , _____ |
| 5.B/L Driving Method : | <input type="checkbox"/> Pass | <input type="checkbox"/> NG , _____ |
| 6.Negative Voltage Output : | <input type="checkbox"/> Pass | <input type="checkbox"/> NG , _____ |
| 7.Interface Function : | <input type="checkbox"/> Pass | <input type="checkbox"/> NG , _____ |
| 8.LCD Uniformity : | <input type="checkbox"/> Pass | <input type="checkbox"/> NG , _____ |
| 9.ESD test : | <input type="checkbox"/> Pass | <input type="checkbox"/> NG , _____ |
| 10.Others : | <input type="checkbox"/> Pass | <input type="checkbox"/> NG , _____ |
| 6 、 <u>Summary</u> : | | |
| <p style="margin-top: 0;">Sales signature : _____</p> <p>Customer Signature : _____ <u>Date</u> : / /</p> | | |