



RAYSTAR

曜凌光電股份有限公司

住址: 42878 台中縣大雅鄉科雅路 25 號 5F WEB: <http://www.Raystar-Optronics.com>
5F, No.25, keya Rd. Daya Township, E-mail: sales@raystar-optronics.com
Taichung County, Taiwan Tel:886-4-2565-0761 Fax : 886-4-2565-0760

RG128128B-TIW-V

SPECIFICATION

CUSTOMER:

APPROVED BY	
PCB VERSION	
DATE	

FOR CUSTOMER USE ONLY

SALES BY	APPROVED BY	CHECKED BY	PREPARED BY

ISSUED DATE:

Contents

	Page
1. Revision History	3
2. General Specification	4
3. Module Coding System	5
4. Interface Pin Function	6
5. Outline dimension & Block Diagram	7
6. Display Control Instruction	8
7. Timing Characteristics	19
8. Optical Characteristics	20
9. Absolute Maximum Ratings	21
10. Electrical Characteristics	21
11. Backlight Information	22
12. Reliability	23
13. Inspection specification	24
14. Precautions in use of LCD Modules	28
15. Material List of Components for RoHs	29

1. Revision History

DATE	VERSION	REVISED PAGE NO.	Note
2009/1/21	1		First issue

RAYSTAR OPTRONICS

2. General Specification

The Features is described as follow:

- Module dimension: 72.5×69.9×10.2 (max.) mm³
- View area: 50.0×49.0 mm²
- Active area: 44.77×44.77 mm²
- Number of Dots: 128 x 128
- Dot size: 0.32×0.32 mm²
- Dot pitch: 0.35×0.35 mm²
- LCD type: FSTN Negative Transmissive
- Duty: 1/128
- View direction: 6 o'clock
- Backlight: LED, WHITE

3. Module Coding System

R	G	128128	B	-	T	I	W	-	V
1	2	3	4	-	5	6	7	-	8

Item	Description		
1	R : Raystar Optronics Inc.		
2	Display	C : Character Type, G : Graphic Type	
3	Number of dots : 128 x128 Dots		
4	Serials code		
5	LCD	P : TN Positive, Gray	
		N : TN Negative,	
		G : STN Positive, Gray	
		Y : STN Positive, Yellow Green	
		B : STN Negative, Blue	
		F : FSTN Positive	
		T : FSTN Negative	
6	Polarizer Type, Temperature range, View direction	A : Reflective, N.T, 6:00	K : Transflective, W.T,12:00
		D : Reflective, N.T, 12:00	1 : Transflective, U.T,6:00
		G : Reflective, W. T, 6:00	4 : Transflective, U.T.12:00
		J : Reflective, W. T, 12:00	C : Transmissive, N.T,6:00
		0 : Reflective, U. T, 6:00	F : Transmissive, N.T,12:00
		3 : Reflective, U. T, 12:00	I : Transmissive, W. T, 6:00
		B : Transflective, N.T,6:00	L : Transmissive, W.T,12:00
		E : Transflective, N.T.12:00	2 : Transmissive, U. T, 6:00
		H : Transflective, W.T,6:00	5 : Transmissive, U.T,12:00
7	Backlight	N : Without backlight	Y : LED, Yellow Green
		P : EL, Blue green	A : LED, Amber
		T : EL, Green	W : LED, White
		D : EL, White	O : LED, Orange
		F : CCFL, White	G : LED, Green
8	Special code	V: Built-in Negative Voltage	

4. Interface Pin Function

Pin #	Symbol	Level	Description
1	DB0	H / L	Data bus line
2	DB1	H / L	Data bus line
3	DB2	H / L	Data bus line
4	DB3	H / L	Data bus line
5	DB4	H / L	Data bus line
6	DB5	H / L	Data bus line
7	DB6	H / L	Data bus line
8	DB7	H / L	Data bus line
9	RS	H / L	H : Instruction , L : Data
10	R / \overline{W}	H / L	H : read , L : write
11	E	H / L	Enable
12	\overline{CS}	L	Chip enable active " L "
13	\overline{RES}	L	Reset active " L "
14	V _o		Power supply for LCD
15	V _{dd}		Power supply for logic circuit
16	V _{ss}		Ground
17	V _{ee}		Negative voltage output
18	dispof		No Connection
19	LED(+)		LED +
20	LED(-)		LED-

5. Outline Dimension & Block Diagram

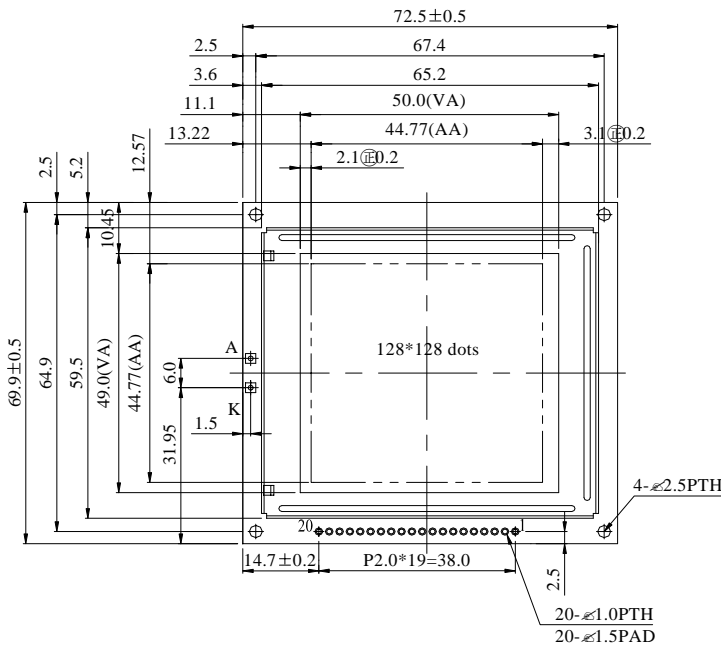

PIN NO.	SYMBOL
1	DB0
2	DB1
3	DB2
4	DB3
5	DB4
6	DB5
7	DB6
8	DB7
9	RS
10	R/W
11	E
12	CS
13	RES
14	Vo
15	Vdd
16	Vss
17	Vee
18	Dispof
19	LED(+)
20	LED(-)

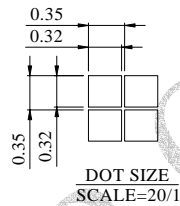

The non-specified tolerance of dimension is ±0.3mm

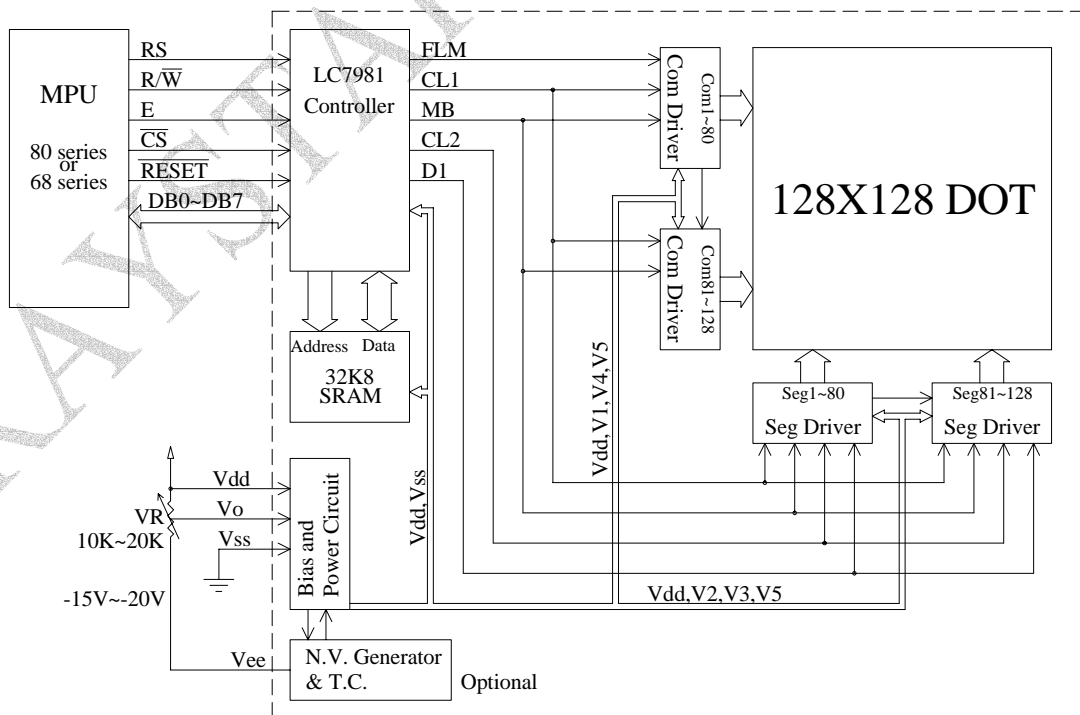

External contrast adjustment.

6. Display Control Instruction

The LCM has built-in a LC7981 LSI Controller, it stores display data sent from the 8 bit microcomputer in the display RAM attached externally and generates dot matrix LC drive signal. The LC7981 has two modes-the graphic mode, in which each bit of data from the external RAM either lights or doesn't light a dot in the LCD, and the character mode in which character codes stored in the external RAM generate dot patterns through the built-in character-generator ROM (CGROM) below is its block diagram. Description of each block.

• Register

The LC7981 has 5 types of registers-the instruction register, data input register, data output register, dot register, and mode control register.

The instruction register stores such instruction codes as the start address, cursor address specification, etc. It consists of 4 bits, and the lower 4 bits of the data bus, DB0 to DB3, are written into it.

The data input register temporarily stores data to be written into the external RAM, dot register, and mode control register. It consists of 8 bits.

The data output register temporarily stores data to be read from external RAM, and consists of 8 bits. What the cursor address is written into the cursor address counter via the data input register and the memory read instruction is set in the instruction register, data in external RAM is read into the data output register by internal operation. With the next instruction, the MPU reads the data output register, and completes data transfer to the MPU.

The dot register stores dot information such as the character pitch, the number of vertical dots, etc. Data sent from the MPU is written into the dot register via the data input register.

The mode control register stores LCD status information such as display on/off and cursor on/off/blink. It consists of 6 bits. Data sent from the MPU is written into this register via the data input register.

• Busy flag

When the Busy flag is "1", the LC7981 is operating internally. At this time, the next instruction cannot be accepted. The Busy flag is output to DB7 when RS=1, RW=1. The next instruction must be written after ensuring that the Busy flag is "0". When the maximum value of the read cycle time or write cycle time has been passed after the execution of the preceding data read instruction or data write instruction, the next instruction can be executed without checking the Busy flag.

- **Character generator ROM**

The character generator ROM has a total of 7360 bits and stores data on 192 kinds of characters. Character codes from the external RAM and row codes from the row address counter are added to address signals, and ROM outputs 5-bit dot data.

There are 192 kinds of character fonts, of which 160 are 5×7 and 32 are 5×11. With extended ROM, character fonts can be increased to 256 kinds sized 8×16.

- **Cursor address counter**

The cursor address counter is a 16-bit counter which can be preset by instruction.. When data is read from or written into external RAM (i. e., read/write of display dot data or character codes), the counter retains the addresses. The value indicated on the cursor address counter is automatically incremented by 1 when instructions to read/write display data and to perform bit set/clear are issued.

- **Cursor signal generator**

In the character mode, the cursor can be displayed by means of instructions. The cursor is generated automatically when the cursor address counter and the row address counter reach the specified value.

- **Display control instruction**

Display is controlled by writing data into the instruction register and 13 data registers. The instruction register and the data register are distinguished by the RS signal. First, write 4-bit data in the instruction register when RS=1, then specify the code of the data register. Next, with RS=0, write 8-bit data in the data register, which executes the specified instruction.

A new instruction cannot be accepted while an old instruction is being executed. As the Busy flag is set under this condition, write an instruction only after reading the Busy flag and making sure that it is 0.

However, the next instruction can be executed without checking the Busy flag when the maximum read cycle time or the write cycle time has been exceeded after execution of the previous data read instruction or the data write instruction. The Busy flag does not change when data is written into the instruction register (RS=1). Therefore, the Busy flag need not be checked immediately after writing data into the instruction register.

1) Mode control

Write code “00H” (in hexadecimal notation) in the instruction register and specify the mode control register.

Register	R/W	RS	DB7	DB6	DB5	DB4	DB3	DB2	DB1	DB0
Instruction Reg.	0	1	0	0	0	0	0	0	0	0
Mode control Reg.	0	0	0	0	MODE Data					

DB5	DB4	DB3	DB2	DB1	DB0	Cursor/blink	CG	Graphic/character display
1/0	1/0	0	0	0	0	Cursor OFF	Built-in CG	Character display
		0	1			Cursor ON		
		1	0			Cursor OFF character blink		
		1	1			Cursor blink		
		0	0			Cursor OFF	External CG	
		0	1			Cursor ON		
		1	0			Cursor OFF character blink		
		1	1			Cursor blink		
		0	0			1		
Display ON/OFF	Master/slave	Blink	Cursor	Mode	External/ Built in CG			

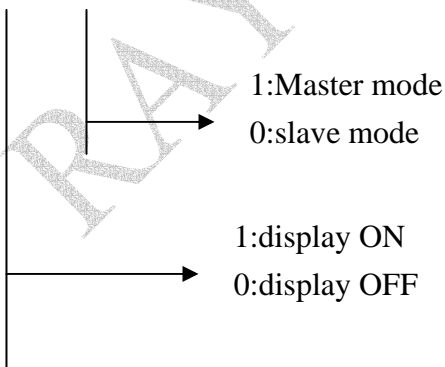

2)Setting the character pitch

Register	R/W	RS	DB7	DB6	DB5	DB4	DB3	DB2	DB1	DB0
Instruction Reg.	0	1	0	0	0	0	0	0	0	1
Character pitch Reg.	0	0	(Vp-1) Binary				0	(Hp-1) Binary		

Vp is the number of vertical dots per character. Determine Vp with the pitch between two vertically placed characters taken into consideration. This value is meaningful only in the character display mode: It is invalid in the graphic mode.

In Character mode. Hp indicates the number of horizontal dots per character, from the leftmost part of one character to the leftmost part of the next. In the graphic mode, Hp indicates how many bits (or dots) from RAM appear in a 1-byte display.

Hp must take one of the following three values.

Hp	DB2	DB1	DB0	
6	1	0	1	Horizontal character pitch 6
7	1	1	0	Horizontal character pitch 7
8	1	1	1	Horizontal character pitch 8

3)Setting the number of characters

Register	R/W	RS	DB7	DB6	DB5	DB4	DB3	DB2	DB1	DB0
Instruction Reg.	0	1	0	0	0	0	0	0	1	0
Character number Reg.	0	0	(H _N -1) Binary							

in the character display mode, H_N indicates the number of characters in the horizontal direction. In the graphic mode, it indicates the number of bytes in the horizontal direction. The total number of dots positioned horizontally on the screen n is given by the formula

$$n = H_p \times H_N$$

Even numbers in the range 2 to 256 (decimal) can be set as H_N.

4)Setting the time division number (display duty)

Register	R/W	RS	DB7	DB6	DB5	DB4	DB3	DB2	DB1	DB0
Instruction Reg.	0	1	0	0	0	0	0	0	1	1
Time division Reg.	0	0	(N _x -1) Binary							

Consequently, 1/N_x is the display duty.

Decimal numbers with the range 1 to 256 can be set as N_x. please set N_x=64

5)Setting the cursor position

Register	R/W	RS	DB7	DB6	DB5	DB4	DB3	DB2	DB1	DB0
Instruction Reg.	0	1	0	0	0	0	0	1	0	0
Cursor position Reg.	0	0	0	0	0	0	(Cp-1) Binary			

In the character display mode, Cp indicates the line at which the cursor is displayed. For example, when Cp=8 (decimal) is specified, the cursor is displayed beneath the character of the 5×7 dot-font. The horizontal length of the cursor equals Hp (the horizontal character pitch). Decimal values in the range 1 to 16 can be assigned to Cp. When the value is less than the vertical character pitch Vp($Cp \leq Vp$), display priority is given to the cursor (provided the cursor display is ON). The cursor is not displayed when $CP > Vp$. The horizontal length of the cursor equals Hp.

6)Setting the display start lower address

Register	R/W	RS	DB7	DB6	DB5	DB4	DB3	DB2	DB1	DB0
Instruction Reg.	0	1	0	0	0	0	1	0	0	0
Display start address Reg. (lower byte)	0	0	(start address lower byte) binary							

7)Setting the display start upper address

Register	R/W	RS	DB7	DB6	DB5	DB4	DB3	DB2	DB1	DB0
Instruction Reg.	0	1	0	0	0	0	1	0	0	1
Display start address Reg. (upper byte)	0	0	(start address upper byte) binary							

This instruction writes the display start value in the display start address register. The display start address inn the RAM address at which data to be displayed at the leftmost position of the top line of the screen is stored. The start address consists of 16 bits (upper and lower).

8)Setting the cursor (lower) address (RAM read/write lower address)

Register	R/W	RS	DB7	DB6	DB5	DB4	DB3	DB2	DB1	DB0
Instruction Reg.	0	1	0	0	0	0	1	0	1	0
Cursor address counter (lower byte)	0	0	(cursor address lower byte) binary							

9)Setting the cursor (upper) address (RAM read/write upper address)

Register	R/W	RS	DB7	DB6	DB5	DB4	DB3	DB2	DB1	DB0
Instruction Reg.	0	1	0	0	0	0	1	0	1	1
Cursor address counter (upper byte)	0	0	(cursor address upper byte) binary							

This instruction writes the cursor address value in the cursor address counter. The cursor address indicates the address for exchanging display data and character codes with RAM. In other words, data at the address specified by the cursor address is read from or written into RAM. In character display, the cursor is displayed at the position specified by the cursor address. The cursor address is divided into a lower address (8 bits) and an upper address (8 bits). It should be set in accordance with the following rules.

1	To rewrite (set) both lower and upper addresses.	First set the lower address, then the upper.
2	To rewrite the lower address:	Always reset the upper address after setting the lower address.
3	To rewrite the upper address only:	Set the upper address. It is necessary to reset the lower address.

The cursor address counter is a 16-bit up-counter with set/reset functions: when the Nth bit goes from 1 to 0, the count of the (N+1)th bit increments by one. Accordingly, when the lower address is set so that the lower MSB (8th bit) changes from 1 to 0, the LSB (1st bit) of the upper counter must increment by one. When setting the cursor address, set the lower and upper addresses as a 2-byte continuous instruction.

10)Writing display data

Register	R/W	RS	DB7	DB6	DB5	DB4	DB3	DB2	DB1	DB0
Instruction Reg.	0	1	0	0	0	0	1	1	0	0
RAM	0	0	MSB (pattern data, character code)				LSB			

Write code "0CH" in the instruction register. Then, write 8-bit data with RS=0, and the data is written into RAM as display data or character codes at the address specified by the cursor address counter. After writing, the count of the cursor address counter increments by 1.

11) Reading display data

Register	R/W	RS	DB7	DB6	DB5	DB4	DB3	DB2	DB1	DB0	
Instruction Reg.	0	1	0	0	0	0	1	1	0	1	
RAM	1	0	MSB (pattern data, character code)						LSB		

Write "0DH" in the instruction register. Then, establish the read status with RS=0, and data in the RAM can be read. The procedure for reading data is as follows.

This instruction outputs the contents of the data output register to DB0 to 7, then transfers the RAM data indicated by the cursor address to the data output register. It then increments the cursor address by 1, which means that correct data cannot be read in the first read operation. The specified value is output in the second read operation. Accordingly, a dummy read operation must be performed once when reading data after setting the cursor address.

12) Bit clear

Register	R/W	RS	DB7	DB6	DB5	DB4	DB3	DB2	DB1	DB0
Instruction Reg.	0	1	0	0	0	0	1	1	1	0
Bit clear	0	0	0	0	0	0	0	(N _B -1) Binary		

13) Bit set

Register	R/W	RS	DB7	DB6	DB5	DB4	DB3	DB2	DB1	DB0
Instruction Reg	0	1	0	0	0	0	1	1	1	1
Bit set	0	0	0	0	0	0	0	(N _B -1) Binary		

As the bit-clear or bit-set instruction, 1 bit of a 1 byte of data in display RAM is set to 0 or 1. The bit specified by N_B is set to 0 for the bit-clear instruction and 1 for the bit-set instruction. The RAM address is specified by the cursor address, which is automatically incremented by 1 at the completion of the instruction. N_B is a value in the range from 1 to 8. The LSB is indicated by N_B=1, and the MSB by N_B=8.

14) Reading the BUSY flag

Register	R/W	RS	DB7	DB6	DB5	DB4	DB3	DB2	DB1	DB0
busy flag	1	1	1/0	*						

The Busy flag is output to DB7 when read mode is established with RS=1. The Busy flag is set to 1 while any of the instructions 1) through 13) is being executed. It is set to 0 at the completion of the execution, allowing the next instruction to be accepted. No other instruction can be accepted when the Busy flag is 1. Accordingly, before writing an instruction and data, it is necessary to ensure that the Busy flag is 0. However, the next instruction can be executed without checking the

Busy flag when the maximum read cycle time or the write cycle time has been exceeded after execution of the previous data read instruction or the data write instruction.

The Busy flag does not change when data is written into the instruction register (RS=1). Therefore, the Busy flag need not be checked immediately after writing data into the instruction register.

Specification of the instruction register is unnecessary to read the Busy flag.

The relation between the LCD panel display and H_p , H_N , C_p , V_p , and N_x

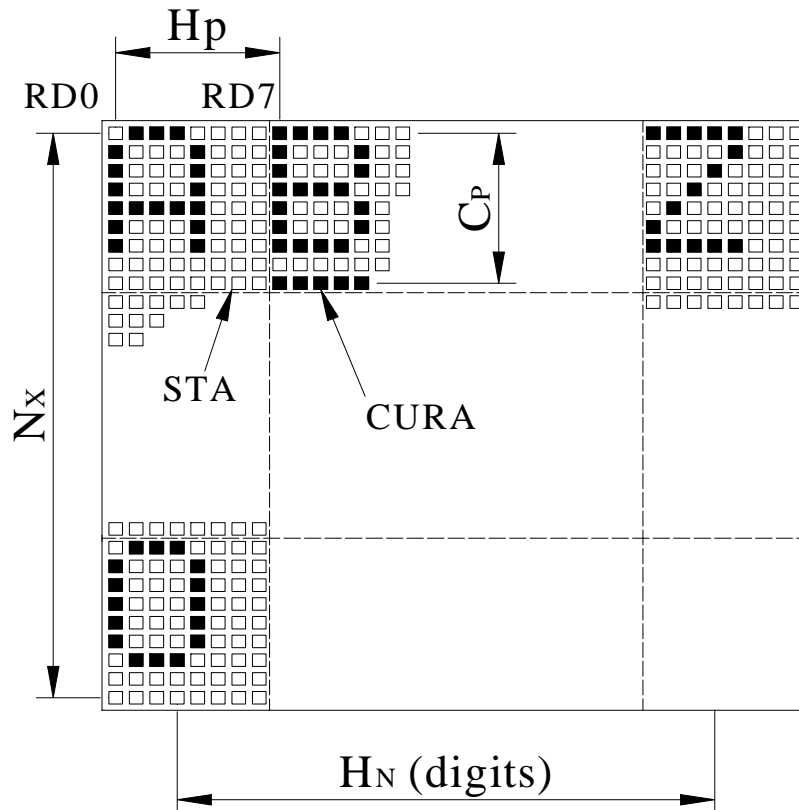

$$C_p \leq V_p$$

Symbol	Description	Contents	Value
H_p	Horizontal character pitch	Character pitch in the horizontal direction	6 to 8 dots
H_N	Number of characters in the horizontal direction	Number of characters (digits) per horizontal line or the number of words per line (graphic)	Even digits in the range 2 to 256
V_p	Vertical character pitch	character pitch in the vertical direction	1 to 16 dots
C_p	Cursor position	The line number at which the cursor is to be displayed	1 to 16 lines
N_x	Number of lines in the vertical direction	Display duty	1 to 256 lines

Note)

When the number of vertical dots on the screen is m and that of horizontal dots is n,

$$1/m = 1/N_x = \text{display duty (nx=64)}$$

$$n = H_p \times H_N$$

$$m/V_p = \text{number of display lines, } C_p \leq V_p$$

RAYSTAR OPTRONICS

Display mode

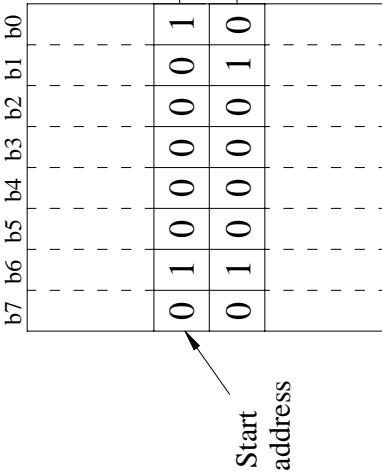
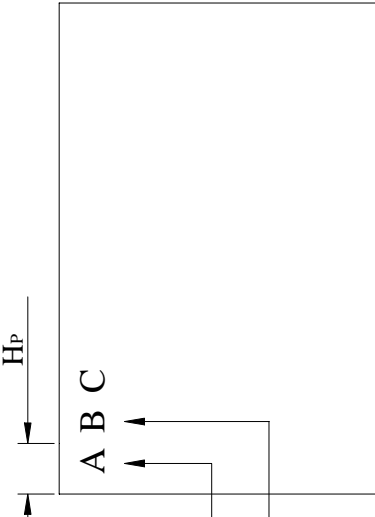
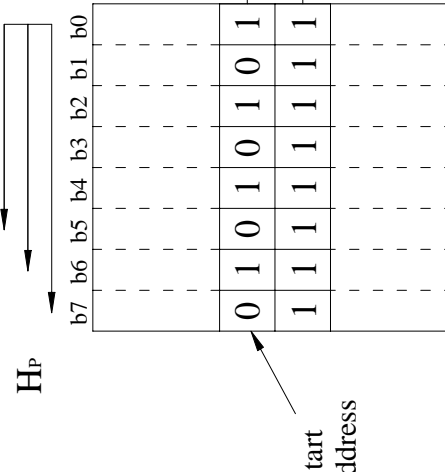
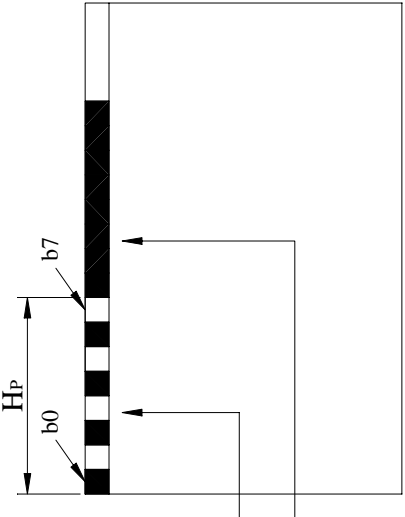
Display mode	Display data from the MPU	RAM	LCD Panel																																																																																								
Character display	Display pattern (8 Bits)	 <p>RAM bit patterns for characters A, B, and C:</p> <table border="1"> <tr><td>b7</td><td></td><td></td><td></td><td></td><td></td><td></td><td></td></tr> <tr><td>b6</td><td></td><td></td><td></td><td></td><td></td><td></td><td></td></tr> <tr><td>b5</td><td></td><td></td><td></td><td></td><td></td><td></td><td></td></tr> <tr><td>b4</td><td></td><td></td><td></td><td></td><td></td><td></td><td></td></tr> <tr><td>b3</td><td></td><td></td><td></td><td></td><td></td><td></td><td></td></tr> <tr><td>b2</td><td></td><td></td><td></td><td></td><td></td><td></td><td></td></tr> <tr><td>b1</td><td></td><td></td><td></td><td></td><td></td><td></td><td></td></tr> <tr><td>b0</td><td></td><td></td><td></td><td></td><td></td><td></td><td></td></tr> <tr><td colspan="8">Start address</td></tr> <tr><td></td><td>0</td><td>1</td><td>0</td><td>0</td><td>0</td><td>0</td><td>1</td></tr> <tr><td></td><td>0</td><td>1</td><td>0</td><td>0</td><td>0</td><td>1</td><td>0</td></tr> </table>	b7								b6								b5								b4								b3								b2								b1								b0								Start address									0	1	0	0	0	0	1		0	1	0	0	0	1	0	 <p>HP: 6, 7 or 8 dots</p>
b7																																																																																											
b6																																																																																											
b5																																																																																											
b4																																																																																											
b3																																																																																											
b2																																																																																											
b1																																																																																											
b0																																																																																											
Start address																																																																																											
	0	1	0	0	0	0	1																																																																																				
	0	1	0	0	0	1	0																																																																																				
Graphic	Character code (8 Bits)	 <p>RAM bit patterns for a vertical bar:</p> <table border="1"> <tr><td>b7</td><td></td><td></td><td></td><td></td><td></td><td></td><td></td></tr> <tr><td>b6</td><td></td><td></td><td></td><td></td><td></td><td></td><td></td></tr> <tr><td>b5</td><td></td><td></td><td></td><td></td><td></td><td></td><td></td></tr> <tr><td>b4</td><td></td><td></td><td></td><td></td><td></td><td></td><td></td></tr> <tr><td>b3</td><td></td><td></td><td></td><td></td><td></td><td></td><td></td></tr> <tr><td>b2</td><td></td><td></td><td></td><td></td><td></td><td></td><td></td></tr> <tr><td>b1</td><td></td><td></td><td></td><td></td><td></td><td></td><td></td></tr> <tr><td>b0</td><td></td><td></td><td></td><td></td><td></td><td></td><td></td></tr> <tr><td colspan="8">Start address</td></tr> <tr><td></td><td>0</td><td>1</td><td>0</td><td>1</td><td>0</td><td>1</td><td>1</td></tr> <tr><td></td><td>1</td><td>1</td><td>1</td><td>1</td><td>1</td><td>1</td><td>1</td></tr> </table>	b7								b6								b5								b4								b3								b2								b1								b0								Start address									0	1	0	1	0	1	1		1	1	1	1	1	1	1	 <p>HP: 8 dots</p>
b7																																																																																											
b6																																																																																											
b5																																																																																											
b4																																																																																											
b3																																																																																											
b2																																																																																											
b1																																																																																											
b0																																																																																											
Start address																																																																																											
	0	1	0	1	0	1	1																																																																																				
	1	1	1	1	1	1	1																																																																																				

Built-in Character generator

Upper 4 bit Lower 4 bit	LLLL	LLH	LLHL	LLHH	LHLL	LHLH	LHHL	LHHH	HLLL	HLLH	HLHL	HLHH	HHLL	HHHL	HHHH
LLLL				0	1	2	3	4	5	6	7	8	9	:	;
LLH			!	!	!	!	!	!	!	!	!	!	!	!	!
LLHL			"	"	"	"	"	"	"	"	"	"	"	"	"
LLHH			#	#	#	#	#	#	#	#	#	#	#	#	#
LHLL			\$	\$	\$	\$	\$	\$	\$	\$	\$	\$	\$	\$	\$
LHLH			%	%	%	%	%	%	%	%	%	%	%	%	%
LHHL			&	&	&	&	&	&	&	&	&	&	&	&	&
LHHH			'	'	'	'	'	'	'	'	'	'	'	'	'
HLLL			(((((((((((((
HLLH)))))))))))))
HLHL			*	*	*	*	*	*	*	*	*	*	*	*	*
HLHH			+	+	+	+	+	+	+	+	+	+	+	+	+
HHLL			,	,	,	,	,	,	,	,	,	,	,	,	,
HHLH			-	-	-	-	-	-	-	-	-	-	-	-	-
HHHL		
HHHH			/	/	/	/	/	/	/	/	/	/	/	/	/

7. Timing Characteristics

Read cycle

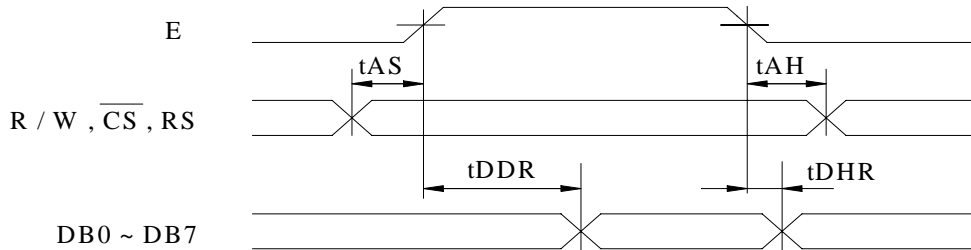

Write cycle

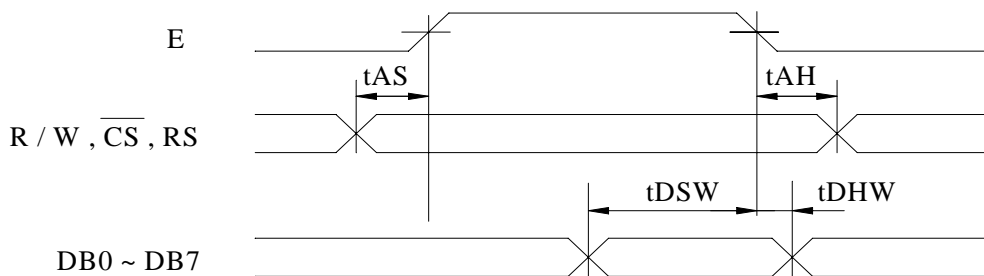

(V_{ss} = 0 V, V_{DD} = 5 V)

Item	Symbol	Min	Typ	Max	Unit
Address set-up time	tAS	90	—	—	ns
Address hold time	tAH	10	—	—	ns
Data delay time (read)	tDDR	—	—	140	ns
Data hold time (read)	tDHR	10	—	—	ns
Data set-up time (write)	tDSW	220	—	—	ns
Data hold time (write)	tDHW	20	—	—	ns

Note : Definition of the test waveform

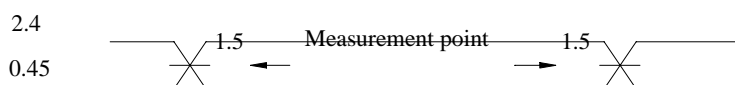

The input terminals are driven at 2.4V and 0.45V. Timing is measured at 1.5V.

8. Optical Characteristics

Item	Symbol	Condition	Min	Typ	Max	Unit
View Angle	(V) θ	$CR \geq 2$	30	—	60	deg
	(H) ϕ	$CR \geq 2$	-45	—	45	deg
Contrast Ratio	CR	—	—	5	—	—
Response Time	T rise	—	—	150	200	ms
	T fall	—	—	150	200	ms

Definitions

■View Angles

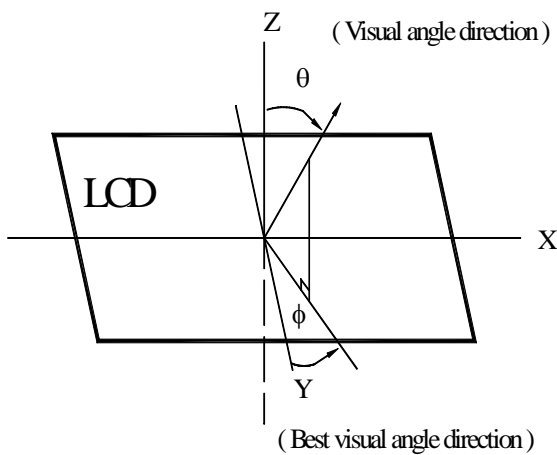

■Contrast Ratio

$$CR = \frac{\text{Brightness at selected state (BS)}}{\text{Brightness at non-selected state (Bns)}}$$

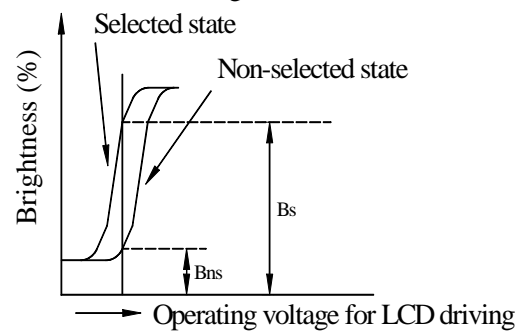

■Response Time

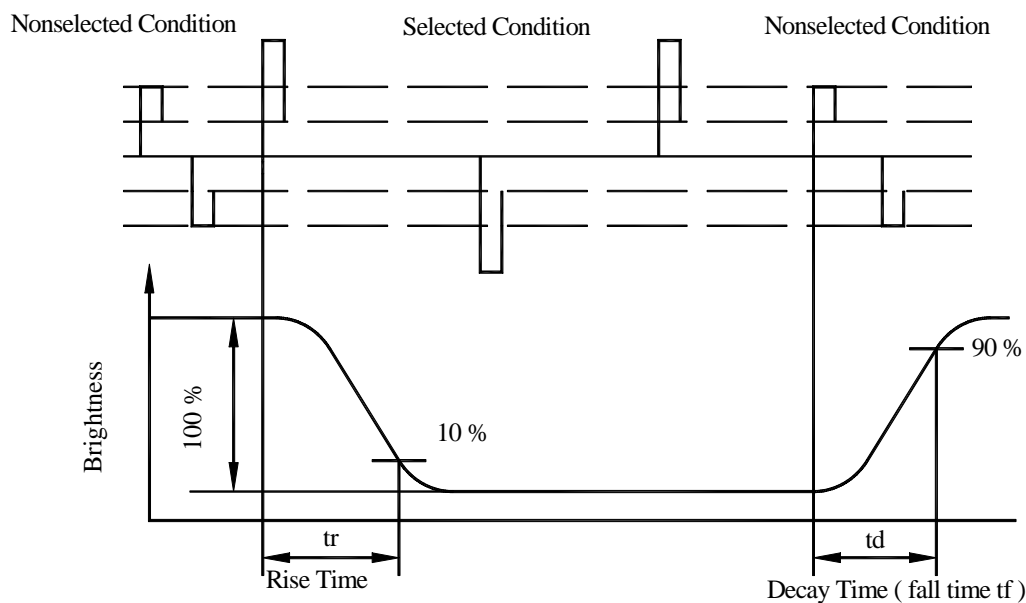

9. Absolute Maximum Ratings

ITEM	SYMBOL	MIN.	TYP.	MAX.	UNIT
Operating Temperature	T_{OP}	20	—	+70	°C
Storage Temperature	T_{ST}	-30	—	+80	°C
Input Voltage	V_I	-0.3	—	V_{DD}	V
Supply Voltage For LCD	$V_{DD}-V_{EE}$	0	—	28	V

10. Electrical Characteristics

ITEM	SYMBOL	CONDITION	MIN.	TYP.	MAX.	UNIT
Supply Voltage For Logic	$V_{DD}-V_{SS}$	—	4.75	5.0	5.25	V
Supply Voltage For LCD	$V_{DD}-V_0$	$T_a=-20^{\circ}\text{C}$	—	—	18.1	V
		$T_a=25^{\circ}\text{C}$	—	16.3	—	V
		$T_a=70^{\circ}\text{C}$	14.8	—	—	V
Input High Volt.	V_{IH}	—	2.2	—	V_{DD}	V
Input Low Volt.	V_{IL}	—	0	—	0.8	V
Output High Volt.	V_{OH}	—	2.4	—	V_{DD}	V
Output Low Volt.	V_{OL}	—	0	—	0.4	V
Supply Current	I_{DD}	$V_{DD}=5\text{V}$	30.0	34.0	38.0	mA

11. Backlight Information

Specification

PARAMETER	SYMBOL	MIN	TYP	MAX	UNIT	TEST CONDITION
Supply Current	I _{LED}	57.6	64	100	mA	V=3.5V
Supply Voltage	V	3.4	3.5	3.6	V	—
Reverse Voltage	V _R	—	—	5	V	—
Luminous Intensity	I _V	120	140	—	CD/M ²	I _{LED} =64mA
Wave Length	λ _p		X=0.30 Y=0.31		nm	I _{LED} =64mA
LED Life Time (For Reference only)	—	—	10K	—	Hr.	I _{LED} ≤ 64mA 25°C, 50-60%RH, (Note 1)
Color	WHITE					

Note: The LED of B/L is drive by current only, drive voltage is for reference only. drive voltage can make driving current under safety area (current between minimum and maximum).

Note1 :10K hours is only an estimate for reference.

.Drive from pin19,pin20

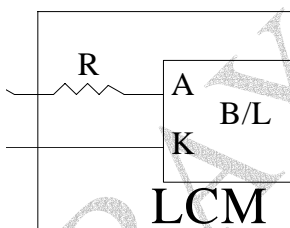

12. Reliability

Content of Reliability Test (wide temperature, -20°C~70°C)

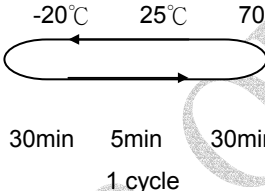
Environmental Test			
Test Item	Content of Test	Condition	Note
High Temperature storage	Endurance test applying the high storage temperature for a long time.	80°C 200hrs	2
Low Temperature storage	Endurance test applying the high storage temperature for a long time.	-30°C 200hrs	1,2
High Temperature Operation	Endurance test applying the electric stress (Voltage & Current) and the thermal stress to the element for a long time.	70°C 200hrs	-
Low Temperature Operation	Endurance test applying the electric stress under low temperature for a long time.	-20°C 200hrs	1
High Temperature/ Humidity Operation	The module should be allowed to stand at 60°C,90%RH max For 96hrs under no-load condition excluding the polarizer, Then taking it out and drying it at normal temperature.	60°C,90%RH 96hrs	1,2
Thermal shock resistance	<p>The sample should be allowed stand the following 10 cycles of operation</p>  <p style="text-align: center;">-20°C 25°C 70°C</p> <p style="text-align: center;">30min 5min 30min</p> <p style="text-align: center;">1 cycle</p>	-20°C/70°C 10 cycles	-
Vibration test	Endurance test applying the vibration during transportation and using.	fixed amplitude: 15mm Vibration. Frequency: 10~55Hz. One cycle 60 seconds to 3 directions of X,Y,Z for Each 15 minutes	3
Static electricity test	Endurance test applying the electric stress to the terminal.	VS=800V,RS= 1.5kΩ CS=100pF 1 time	—

Note1: No dew condensation to be observed.

Note2: The function test shall be conducted after 4 hours storage at the normal temperature and humidity after remove from the test chamber.

Note3: Vibration test will be conducted to the product itself without putting it in a container.

13. Inspection specification

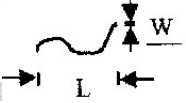
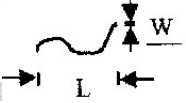
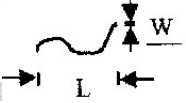
NO	Item	Criterion	AQL																	
01	Electrical Testing	1.1 Missing vertical, horizontal segment, segment contrast defect. 1.2 Missing character, dot or icon. 1.3 Display malfunction. 1.4 No function or no display. 1.5 Current consumption exceeds product specifications. 1.6 LCD viewing angle defect. 1.7 Mixed product types. 1.8 Contrast defect.	0.65																	
02	Black or white spots on LCD (display only)	2.1 White and black spots on display $\leq 0.25\text{mm}$, no more than three white or black spots present. 2.2 Densely spaced: No more than two spots or lines within 3mm	2.5																	
03	LCD black spots, white spots, contamination (non-display)	3.1 Round type : As following drawing $\Phi = (x + y) / 2$	2.5																	
		3.2 Line type : (As following drawing) <table border="1" style="margin-left: 20px;"> <tr> <td style="text-align: center;">  </td> <td style="text-align: center;">Length</td> <td style="text-align: center;">Width</td> <td style="text-align: center;">Acceptable QTY</td> </tr> <tr> <td></td> <td style="text-align: center;">---</td> <td style="text-align: center;">$W \leq 0.02$</td> <td style="text-align: center;">Accept no dense</td> </tr> <tr> <td></td> <td style="text-align: center;">$L \leq 3.0$</td> <td style="text-align: center;">$0.02 < W \leq 0.03$</td> <td style="text-align: center;">2</td> </tr> <tr> <td></td> <td style="text-align: center;">$L \leq 2.5$</td> <td style="text-align: center;">$0.03 < W \leq 0.05$</td> <td style="text-align: center;">2</td> </tr> <tr> <td></td> <td style="text-align: center;">---</td> <td style="text-align: center;">$0.05 < W$</td> <td style="text-align: center;">As round type</td> </tr> </table>			Length	Width	Acceptable QTY		---	$W \leq 0.02$	Accept no dense		$L \leq 3.0$	$0.02 < W \leq 0.03$	2		$L \leq 2.5$	$0.03 < W \leq 0.05$	2	
	Length	Width	Acceptable QTY																	
	---	$W \leq 0.02$	Accept no dense																	
	$L \leq 3.0$	$0.02 < W \leq 0.03$	2																	
	$L \leq 2.5$	$0.03 < W \leq 0.05$	2																	
	---	$0.05 < W$	As round type																	
04	Polarizer bubbles	If bubbles are visible, judge using black spot specifications, not easy to find, must check in specify direction. <table border="1" style="margin-left: 20px;"> <tr> <td style="text-align: center;">Size Φ</td> <td style="text-align: center;">Acceptable QTY</td> </tr> <tr> <td style="text-align: center;">$\Phi \leq 0.20$</td> <td style="text-align: center;">Accept no dense</td> </tr> <tr> <td style="text-align: center;">$0.20 < \Phi \leq 0.50$</td> <td style="text-align: center;">3</td> </tr> <tr> <td style="text-align: center;">$0.50 < \Phi \leq 1.00$</td> <td style="text-align: center;">2</td> </tr> <tr> <td style="text-align: center;">$1.00 < \Phi$</td> <td style="text-align: center;">0</td> </tr> <tr> <td style="text-align: center;">Total QTY</td> <td style="text-align: center;">3</td> </tr> </table>	Size Φ	Acceptable QTY	$\Phi \leq 0.20$	Accept no dense	$0.20 < \Phi \leq 0.50$	3	$0.50 < \Phi \leq 1.00$	2	$1.00 < \Phi$	0	Total QTY	3	2.5					
Size Φ	Acceptable QTY																			
$\Phi \leq 0.20$	Accept no dense																			
$0.20 < \Phi \leq 0.50$	3																			
$0.50 < \Phi \leq 1.00$	2																			
$1.00 < \Phi$	0																			
Total QTY	3																			

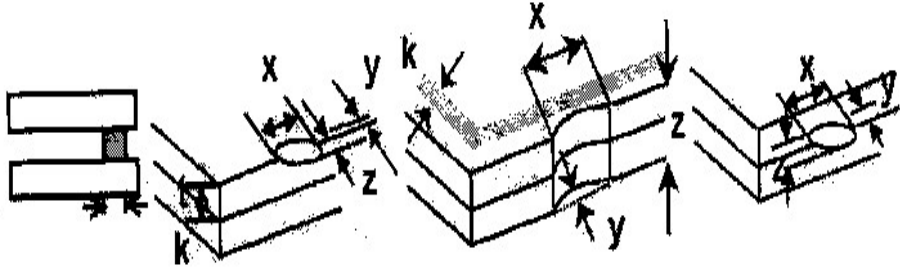
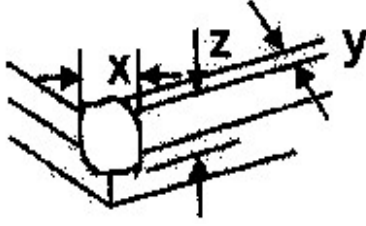
NO	Item	Criterion	AQL																		
05	Scratches	Follow NO.3 LCD black spots, white spots, contamination																			
06	Chipped glass	<p>Symbols Define: x: Chip length y: Chip width z: Chip thickness k: Seal width t: Glass thickness a: LCD side length L: Electrode pad length:</p> <p>6.1 General glass chip : 6.1.1 Chip on panel surface and crack between panels:</p>  <table border="1" data-bbox="443 1075 1348 1232"> <thead> <tr> <th>z: Chip thickness</th> <th>y: Chip width</th> <th>x: Chip length</th> </tr> </thead> <tbody> <tr> <td>$Z \leq 1/2t$</td> <td>Not over viewing area</td> <td>$x \leq 1/8a$</td> </tr> <tr> <td>$1/2t < z \leq 2t$</td> <td>Not exceed 1/3k</td> <td>$x \leq 1/8a$</td> </tr> </tbody> </table> <p>⊙ If there are 2 or more chips, x is total length of each chip.</p> <p>6.1.2 Corner crack:</p>  <table border="1" data-bbox="443 1612 1348 1769"> <thead> <tr> <th>z: Chip thickness</th> <th>y: Chip width</th> <th>x: Chip length</th> </tr> </thead> <tbody> <tr> <td>$Z \leq 1/2t$</td> <td>Not over viewing area</td> <td>$x \leq 1/8a$</td> </tr> <tr> <td>$1/2t < z \leq 2t$</td> <td>Not exceed 1/3k</td> <td>$x \leq 1/8a$</td> </tr> </tbody> </table> <p>⊙ If there are 2 or more chips, x is the total length of each chip.</p>	z: Chip thickness	y: Chip width	x: Chip length	$Z \leq 1/2t$	Not over viewing area	$x \leq 1/8a$	$1/2t < z \leq 2t$	Not exceed 1/3k	$x \leq 1/8a$	z: Chip thickness	y: Chip width	x: Chip length	$Z \leq 1/2t$	Not over viewing area	$x \leq 1/8a$	$1/2t < z \leq 2t$	Not exceed 1/3k	$x \leq 1/8a$	2.5
z: Chip thickness	y: Chip width	x: Chip length																			
$Z \leq 1/2t$	Not over viewing area	$x \leq 1/8a$																			
$1/2t < z \leq 2t$	Not exceed 1/3k	$x \leq 1/8a$																			
z: Chip thickness	y: Chip width	x: Chip length																			
$Z \leq 1/2t$	Not over viewing area	$x \leq 1/8a$																			
$1/2t < z \leq 2t$	Not exceed 1/3k	$x \leq 1/8a$																			

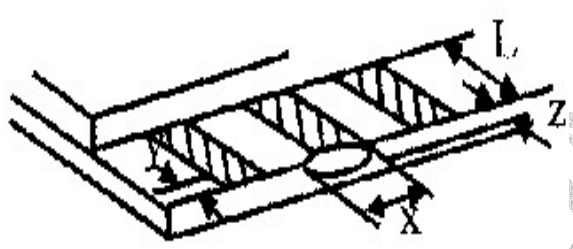
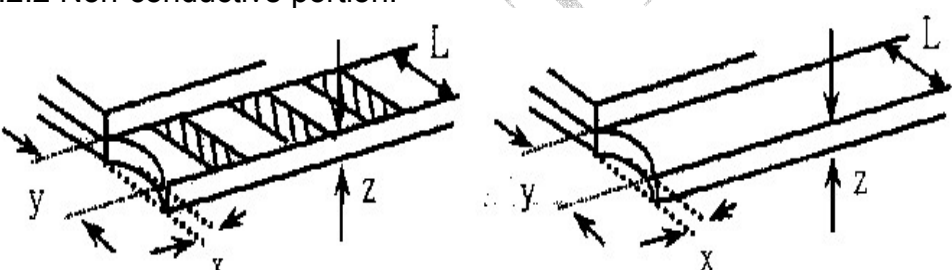
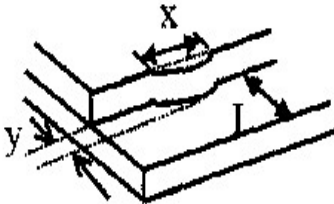
NO	Item	Criterion	AQL						
06	Glass crack	<p>Symbols :</p> <p>x: Chip length y: Chip width z: Chip thickness</p> <p>k: Seal width t: Glass thickness a: LCD side length</p> <p>L: Electrode pad length</p> <p>6.2 Protrusion over terminal :</p> <p>6.2.1 Chip on electrode pad :</p>  <table border="1" data-bbox="343 896 1252 981"> <tr> <td>y: Chip width</td> <td>x: Chip length</td> <td>z: Chip thickness</td> </tr> <tr> <td>$y \leq 0.5\text{mm}$</td> <td>$x \leq 1/8a$</td> <td>$0 < z \leq t$</td> </tr> </table>	y: Chip width	x: Chip length	z: Chip thickness	$y \leq 0.5\text{mm}$	$x \leq 1/8a$	$0 < z \leq t$	2.5
		y: Chip width	x: Chip length	z: Chip thickness					
$y \leq 0.5\text{mm}$	$x \leq 1/8a$	$0 < z \leq t$							
<p>6.2.2 Non-conductive portion:</p>  <table border="1" data-bbox="414 1299 1252 1422"> <tr> <td>y: Chip width</td> <td>x: Chip length</td> <td>z: Chip thickness</td> </tr> <tr> <td>$y \leq L$</td> <td>$x \leq 1/8a$</td> <td>$0 < z \leq t$</td> </tr> </table> <p>⊙ If the chipped area touches the ITO terminal, over 2/3 of the ITO must remain and be inspected according to electrode terminal specifications.</p> <p>⊙ If the product will be heat sealed by the customer, the alignment mark not be damaged.</p>	y: Chip width	x: Chip length	z: Chip thickness	$y \leq L$	$x \leq 1/8a$	$0 < z \leq t$			
y: Chip width	x: Chip length	z: Chip thickness							
$y \leq L$	$x \leq 1/8a$	$0 < z \leq t$							
		<p>6.2.3 Substrate protuberance and internal crack.</p>  <table border="1" data-bbox="750 1668 1260 1758"> <tr> <td>y: width</td> <td>x: length</td> </tr> <tr> <td>$y \leq 1/3L$</td> <td>$x \leq a$</td> </tr> </table>	y: width	x: length	$y \leq 1/3L$	$x \leq a$			
y: width	x: length								
$y \leq 1/3L$	$x \leq a$								

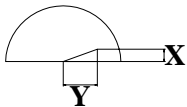
NO	Item	Criterion	AQL
07	Cracked glass	The LCD with extensive crack is not acceptable.	2.5
08	Backlight elements	8.1 Illumination source flickers when lit. 8.2 Spots or scratched that appear when lit must be judged. Using LCD spot, lines and contamination standards. 8.3 Backlight doesn't light or color wrong.	0.65 2.5 0.65
09	Bezel	9.1 Bezel may not have rust, be deformed or have fingerprints, stains or other contamination. 9.2 Bezel must comply with job specifications.	2.5 0.65
10	PCB · COB	10.1 COB seal may not have pinholes larger than 0.2mm or contamination. 10.2 COB seal surface may not have pinholes through to the IC. 10.3 The height of the COB should not exceed the height indicated in the assembly diagram. 10.4 There may not be more than 2mm of sealant outside the seal area on the PCB. And there should be no more than three places. 10.5 No oxidation or contamination PCB terminals. 10.6 Parts on PCB must be the same as on the production characteristic chart. There should be no wrong parts, missing parts or excess parts. 10.7 The jumper on the PCB should conform to the product characteristic chart. 10.8 If solder gets on bezel tab pads, LED pad, zebra pad or screw hold pad, make sure it is smoothed down. 10.9 The Scraping testing standard for Copper Coating of PCB  $X * Y \leq 2\text{mm}^2$	2.5 2.5 0.65 2.5 2.5 0.65 0.65 2.5 2.5
11	Soldering	11.1 No un-melted solder paste may be present on the PCB. 11.2 No cold solder joints, missing solder connections, oxidation or icicle. 11.3 No residue or solder balls on PCB. 11.4 No short circuits in components on PCB.	2.5 2.5 2.5 0.65

NO	Item	Criterion	AQL
12	General appearance	12.1 No oxidation, contamination, curves or, bends on interface Pin (OLB) of TCP.	2.5
		12.2 No cracks on interface pin (OLB) of TCP.	0.65
		12.3 No contamination, solder residue or solder balls on product.	2.5
		12.4 The IC on the TCP may not be damaged, circuits.	2.5
		12.5 The uppermost edge of the protective strip on the interface pin must be present or look as if it causes the interface pin to sever.	2.5
		12.6 The residual rosin or tin oil of soldering (component or chip component) is not burned into brown or black color.	2.5
		12.7 Sealant on top of the ITO circuit has not hardened.	0.65
		12.8 Pin type must match type in specification sheet.	0.65
		12.9 LCD pin loose or missing pins.	0.65
		12.10 Product packaging must the same as specified on packaging specification sheet.	0.65
		12.11 Product dimension and structure must conform to product specification sheet.	0.65

14. Precautions in use of LCD Modules

1. Avoid applying excessive shocks to the module or making any alterations or modifications to it.
2. Don't make extra holes on the printed circuit board, modify its shape or change the components of LCD module.
3. Don't disassemble the LCM.
4. Don't operate it above the absolute maximum rating.
5. Don't drop, bend or twist LCM.
6. Soldering: only to the I/O terminals.
7. Storage: please storage in anti-static electricity container and clean environment.

15. Material List of Components for RoHs

1. RAYSTAR Optronics Co., Ltd. hereby declares that all of or part of products, including, but not limited to, the LCM, accessories or packages, manufactured and/or delivered to your company (including your subsidiaries and affiliated company) directly or indirectly by our company (including our subsidiaries or affiliated companies) do not intentionally contain any of the substances listed in all applicable EU directives and regulations, including the following substances.

Exhibit A : The Harmful Material List

Material	(Cd)	(Pb)	(Hg)	(Cr6+)	PBBs	PBDEs
Limited Value	100 ppm	1000 ppm	1000 ppm	1000 ppm	1000 ppm	1000 ppm
Above limited value is set up according to RoHS.						

2. Process for RoHS requirement :

- (1) Use the Sn/Ag/Cu soldering surface ; the surface of Pb-free solder is rougher than we used before.
- (2) Heat-resistance temp. :
 Reflow : 250°C, 30 seconds Max. ;
 Connector soldering wave or hand soldering : 320°C, 10 seconds max.
- (3) Temp. curve of reflow, max. Temp. : 235±5°C ;
 Recommended customer's soldering temp. of connector : 280°C, 3 seconds.

LCM Sample Estimate Feedback Sheet

Module Number : _____

1 、 Panel Specification :

1. Panel Type :	<input type="checkbox"/> Pass	<input type="checkbox"/> NG , _____
2. View Direction :	<input type="checkbox"/> Pass	<input type="checkbox"/> NG , _____
3. Numbers of Dots :	<input type="checkbox"/> Pass	<input type="checkbox"/> NG , _____
4. View Area :	<input type="checkbox"/> Pass	<input type="checkbox"/> NG , _____
5. Active Area :	<input type="checkbox"/> Pass	<input type="checkbox"/> NG , _____
6. Operating Temperature :	<input type="checkbox"/> Pass	<input type="checkbox"/> NG , _____
7. Storage Temperature :	<input type="checkbox"/> Pass	<input type="checkbox"/> NG , _____
8. Others :	_____	

2 、 Mechanical Specification :

1. PCB Size :	<input type="checkbox"/> Pass	<input type="checkbox"/> NG , _____
2. Frame Size :	<input type="checkbox"/> Pass	<input type="checkbox"/> NG , _____
3. Material of Frame :	<input type="checkbox"/> Pass	<input type="checkbox"/> NG , _____
4. Connector Position :	<input type="checkbox"/> Pass	<input type="checkbox"/> NG , _____
5. Fix Hole Position :	<input type="checkbox"/> Pass	<input type="checkbox"/> NG , _____
6. Backlight Position :	<input type="checkbox"/> Pass	<input type="checkbox"/> NG , _____
7. Thickness of PCB :	<input type="checkbox"/> Pass	<input type="checkbox"/> NG , _____
8. Height of Frame to PCB :	<input type="checkbox"/> Pass	<input type="checkbox"/> NG , _____
9. Height of Module :	<input type="checkbox"/> Pass	<input type="checkbox"/> NG , _____
10. Others :	<input type="checkbox"/> Pass	<input type="checkbox"/> NG , _____

3 、 Relative Hole Size :

1. Pitch of Connector :	<input type="checkbox"/> Pass	<input type="checkbox"/> NG , _____
2. Hole size of Connector :	<input type="checkbox"/> Pass	<input type="checkbox"/> NG , _____
3. Mounting Hole size :	<input type="checkbox"/> Pass	<input type="checkbox"/> NG , _____
4. Mounting Hole Type :	<input type="checkbox"/> Pass	<input type="checkbox"/> NG , _____
5. Others :	<input type="checkbox"/> Pass	<input type="checkbox"/> NG , _____

4 、 Backlight Specification :

1. B/L Type :	<input type="checkbox"/> Pass	<input type="checkbox"/> NG , _____
2. B/L Color :	<input type="checkbox"/> Pass	<input type="checkbox"/> NG , _____
3. B/L Driving Voltage (Reference for LED Type) :	<input type="checkbox"/> Pass	<input type="checkbox"/> NG , _____
4. B/L Driving Current :	<input type="checkbox"/> Pass	<input type="checkbox"/> NG , _____
5. Brightness of B/L :	<input type="checkbox"/> Pass	<input type="checkbox"/> NG , _____
6. B/L Solder Method :	<input type="checkbox"/> Pass	<input type="checkbox"/> NG , _____
7. Others :	<input type="checkbox"/> Pass	<input type="checkbox"/> NG , _____

>> Go to page 2 <<

Module Number : _____		
5 · Electronic Characteristics of Module :		
1.Input Voltage :	<input type="checkbox"/> Pass	<input type="checkbox"/> NG , _____
2.Supply Current :	<input type="checkbox"/> Pass	<input type="checkbox"/> NG , _____
3.Driving Voltage for LCD :	<input type="checkbox"/> Pass	<input type="checkbox"/> NG , _____
4.Contrast for LCD :	<input type="checkbox"/> Pass	<input type="checkbox"/> NG , _____
5.B/L Driving Method :	<input type="checkbox"/> Pass	<input type="checkbox"/> NG , _____
6.Negative Voltage Output :	<input type="checkbox"/> Pass	<input type="checkbox"/> NG , _____
7.Interface Function :	<input type="checkbox"/> Pass	<input type="checkbox"/> NG , _____
8.LCD Uniformity :	<input type="checkbox"/> Pass	<input type="checkbox"/> NG , _____
9.ESD test :	<input type="checkbox"/> Pass	<input type="checkbox"/> NG , _____
10.Others :	<input type="checkbox"/> Pass	<input type="checkbox"/> NG , _____
6 · Summary :		
<p style="text-align: center; font-size: 2em; opacity: 0.2; transform: rotate(-30deg);">RAYSTAR OPTRONICS</p> <p>Sales signature : _____</p> <p>Customer Signature : _____ Date : / / _____</p>		