



Technopolymer wheels

Electro-welded steel bracket for heavy loads

WHEEL CENTRE BODY

Polyamide-based (PA) technopolymer.

ROLLING ACTION

Hub with ball bearings. Ideal solution for heavy loads and continuous moving.

FIXED PLATE BRACKET

Electrolytically zinc-plated electro-welded steel. The bracket is designed to withstand loads up to 9000N and ensures capacities that make it suitable for heavy industrial applications and for severe conditions of use, such as impact and high speeds.

TURNING PLATE BRACKET

Electrolytically zinc-plated electro-welded steel. The presence of an axial bearing and a conical bearing ensures excellent manoeuvrability also at full load and increases the resistance of the bracket against side impact. It is equipped with lubricator and anti-loosening system of the locking nut. The bracket is designed to withstand loads up to 9000N. Suitable for heavy industrial applications and for severe conditions of use, such as impact and high speeds.

It consists of (see fig. 1):

1. fitting plate: forged steel with built-in pin, electrolytically zinc-plated;
2. fork: drawn sides electro-welded to the flange, electrolytically zinc-plated;
3. rotation system: axial ball bearing and conical roller bearing;
4. lubricator;
5. anti-loosening system of the locking nut.

BRAKE

Dual-effect rear brake with simultaneous locking of wheel and bracket. The brake is simple and effective to use: it is actuated and released by a simple action from the top downward at the tip of two separate pedals, thus ensuring the utmost manoeuvring comfort. The braking efficacy may be adjusted with a socket head screw M8.

STANDARD EXECUTIONS

- **PSL-WH**: fixed plate bracket, without brake.
- **SSL-WH**: turning plate bracket, without brake.
- **SSF-WH**: turning plate bracket, with brake.

APPLICATIONS

Suitable for heavy industrial applications, due to loads up to 7500N. Excellent wear and tearing resistance. For further information see RE.F8 on page 1983.

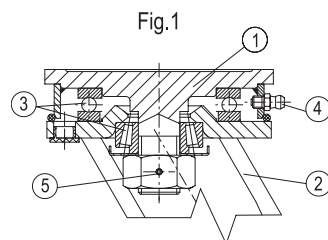

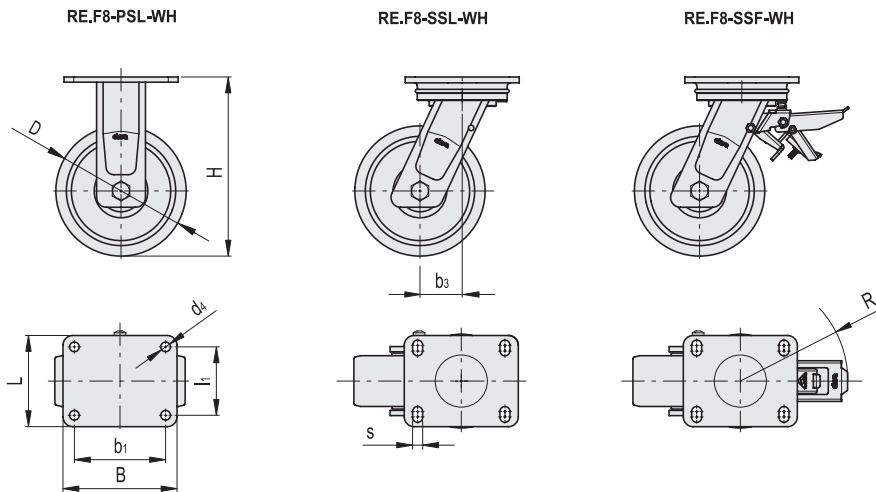

Code	Description	D	d4	l1	H	B	L	s	b1	b3	R	Rolling resistance# [N]	Dynamic carrying capacity# [N]	
449481	RE.F8-125-PSL-WH	125	11	80	182	135	110	-	105	-	-	4000	6500	2280
449482	RE.F8-150-PSL-WH	150	11	80	210	135	110	-	105	-	-	4550	7500	2750
449483	RE.F8-200-PSL-WH	200	11	80	252	135	110	-	105	-	-	6500	9000	3240
449461	RE.F8-125-SSL-WH	125	-	80	182	135	110	11	105	51	-	4000	6500	3510
449462	RE.F8-150-SSL-WH	150	-	80	210	135	110	11	105	60	-	4550	7500	3740
449463	RE.F8-200-SSL-WH	200	-	80	252	135	110	11	105	70	-	6500	9000	4220
449471	RE.F8-125-SSF-WH	125	-	80	182	135	110	11	105	51	157	4000	6500	4390
449472	RE.F8-150-SSF-WH	150	-	80	210	135	110	11	105	60	157	4550	7500	4620
449473	RE.F8-200-SSF-WH	200	-	80	252	135	110	11	105	70	157	6500	9000	5100

For rolling resistance and dynamic carrying capacity see Technical Data on page 2014.