

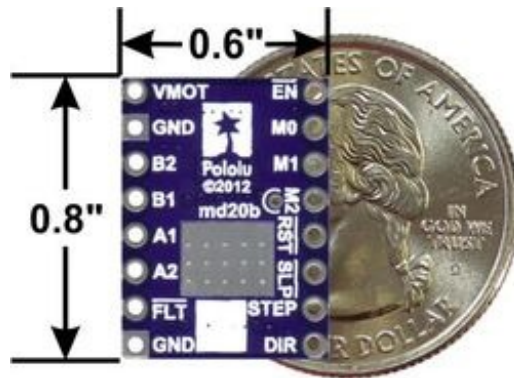

## DRV8824 Stepper Motor Driver Carrier, Low Current



DRV8824/DRV8825 stepper motor driver carrier with dimensions.

### Overview

This product is a carrier board or breakout board for TI's DRV8824 stepper motor driver; we therefore recommend careful reading of the DRV8824 datasheet (1MB pdf) before using this product. This stepper motor driver lets you control one bipolar stepper motor at up to 1.2 A output current per coil (see the Power Dissipation Considerations section below for more information). Here are some of the driver's key features:

- **Simple step and direction control interface**
- **Six different step resolutions: full-step, half-step, 1/4-step, 1/8-step, 1/16-step, and 1/32-step**
- **Adjustable current control lets you set the maximum current output with a potentiometer, which lets you use voltages above your stepper motor's rated voltage to achieve higher step rates**
- **Intelligent chopping control that automatically selects the correct current decay mode (fast decay or slow decay)**
- **45 V maximum supply voltage**
- **Built-in regulator (no external logic voltage supply needed)**
- **Can interface directly with 3.3 V and 5 V systems**
- **Over-temperature thermal shutdown, over-current shutdown, and under-voltage lockout**
- **Short-to-ground and shorted-load protection**
- **4-layer, 2 oz copper PCB for improved heat dissipation**
- **Exposed solderable ground pad below the driver IC on the bottom of the PCB**
- **Module size, pinout, and interface match those of our A4988 stepper motor driver carriers in most respects (see the bottom of this page for more information)**

We also carry a DRV8825 stepper motor driver carrier that can serve as a direct, higher-power substitute for the DRV8824 carrier. The DRV8825 can deliver up to 1.5 A per coil without a heat sink (2.2 A max with sufficient additional cooling). The only way to tell our DRV8824 carrier apart from the DRV8825 carrier is by the markings on the driver IC; if you have a mix of the two, you might consider marking them (there is a blank square on the bottom silkscreen you can use for

this). For lower-voltage applications, consider our pin-compatible DRV8834 carrier, which works with motor supply voltages as low as 2.5 V.

This product ships with all surface-mount components—including the DRV8824 driver IC—installed as shown in the product picture.



Some unipolar stepper motors (e.g. those with six or eight leads) can be controlled by this driver as bipolar stepper motors. For more information, please see the frequently asked questions. Unipolar motors with five leads cannot be used with this driver.

### Included hardware

The DRV8824 stepper motor driver carrier ships with one 1×16-pin breakaway 0.1" male header. The headers can be soldered in for use with solderless breadboards or 0.1" female connectors. You can also solder your motor leads and other connections directly to the board.

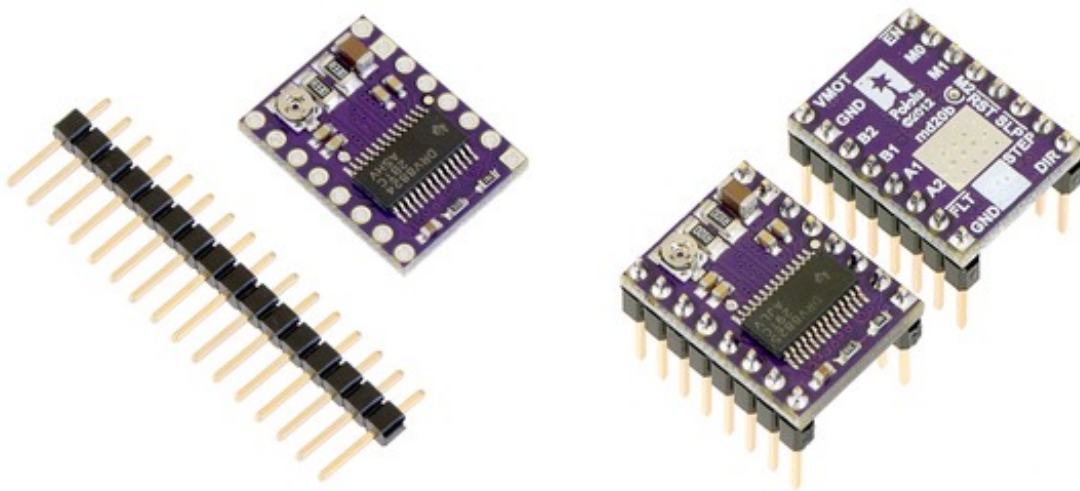

Caution: Installing the header pins so that the silkscreen side is up and the components are down can limit the range of motion of the trimpot used to set the current limit. If you plan on installing the header pins in this orientation, please set the current limit before soldering in the pins.

### Using the driver

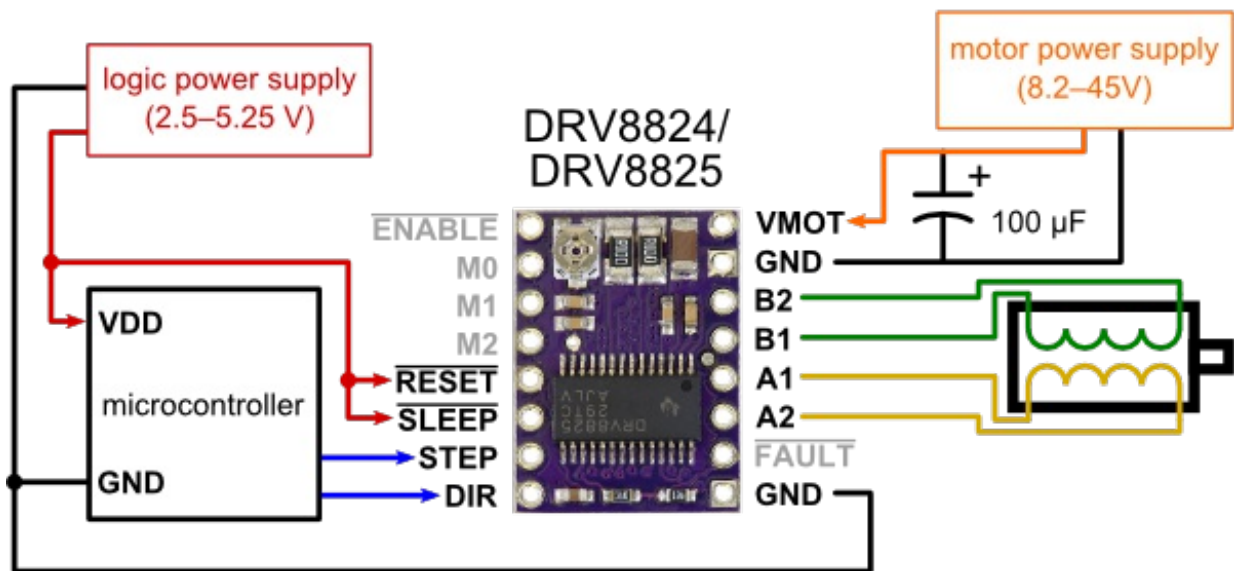

Minimal wiring diagram for connecting a microcontroller to a DRV8824/DRV8825 stepper motor driver carrier (full-step mode).

### Power connections

The driver requires a motor supply voltage of 8.2 – 45 V to be connected across VMOT and GND. This supply should have appropriate decoupling capacitors close to the board, and it should be capable of delivering the expected stepper motor current.

Warning: This carrier board uses low-ESR ceramic capacitors, which makes it susceptible to destructive LC voltage spikes, especially when using power leads longer than a few inches. Under the right conditions, these spikes can exceed the 45 V maximum voltage rating for the DRV8824 and permanently damage the board, even when the motor supply voltage is as low as 12 V. One way to protect the driver from such spikes is to put a large (at least 47 µF) electrolytic capacitor across motor power (VMOT) and ground somewhere close to the board.

### Motor connections

Four, six, and eight-wire stepper motors can be driven by the DRV8824 if they are properly connected; a FAQ answer explains the proper wirings in detail.

Warning: Connecting or disconnecting a stepper motor while the driver is powered can destroy the driver. (More generally, rewiring anything while it is powered is asking for trouble.)

### Step (and microstep) size

Stepper motors typically have a step size specification (e.g.  $1.8^\circ$  or 200 steps per revolution), which applies to full steps. A microstepping driver such as the DRV8824 allows higher resolutions by allowing intermediate step locations, which are achieved by energizing the coils with intermediate current levels. For instance, driving a motor in quarter-step mode will give the 200-step-per-revolution motor 800 microsteps per revolution by using four different current levels.

The resolution (step size) selector inputs (MODE0, MODE1, and MODE2) enable selection from the six step resolutions according to the table below. All three selector inputs have internal 100k $\Omega$  pull-down resistors, so leaving these three microstep selection pins disconnected results in full-step mode. For the microstep modes to function correctly, the current limit must be set low enough (see below) so that current limiting gets engaged. Otherwise, the intermediate current levels will not be correctly maintained, and the motor will skip microsteps.

MODE0	MODE1	MODE2	Microstep Resolution
Low	Low	Low	Full step
High	Low	Low	Half step
Low	High	Low	1/4 step
High	High	Low	1/8 step
Low	Low	High	1/16 step
High	Low	High	1/32 step
Low	High	High	1/32 step
High	High	High	1/32 step

### Control inputs

Each pulse to the STEP input corresponds to one microstep of the stepper motor in the direction selected by the DIR pin. These inputs are both pulled low by default through internal 100k $\Omega$  pull-down resistors. If you just want rotation in a single direction, you can leave DIR disconnected.

The chip has three different inputs for controlling its power states: **RESET**, **SLEEP**, and **ENBL**. For details about these power states, see the datasheet. Please note that the driver pulls the **SLEEP** pin low through an internal 1M $\Omega$  pull-down resistor, and it pulls the **RESET** and **ENBL** pins low through internal 100k $\Omega$  pull-down resistors. These default **RESET** and **SLEEP** states are ones that prevent the driver from operating; both of these pins must be high to enable the driver (they can be connected directly to a logic “high” voltage between 2.2 and 5.25 V, or they can be dynamically controlled via connections to digital outputs of an MCU). The default state of the **ENBL** pin is to enable the driver, so this pin can be left disconnected.

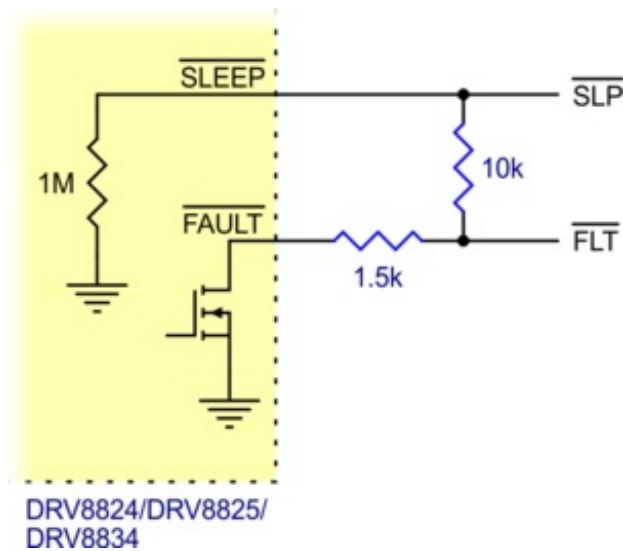

Schematic of nSLEEP and nFAULT pins on DRV8824/DRV8825/DRV8834 carriers.

The DRV8824 also features a **FAULT** output that drives low whenever the H-bridge FETs are disabled as the result of over-current protection or thermal shutdown. The carrier board connects this pin to the **SLEEP** pin through a 10k resistor that acts as a **FAULT** pull-up whenever **SLEEP** is externally held high, so no external pull-up is necessary on the **FAULT** pin. Note that the carrier includes a 1.5k protection resistor in series with the **FAULT** pin that makes it safe to connect this pin directly to a logic voltage supply, as might happen if you use this board in a system designed for the pin-compatible A4988 carrier. In such a system, the 10k resistor between **SLEEP** and **FAULT** would then act as a pull-up for **SLEEP**, making the DRV8824 carrier more of a direct replacement for the A4988 in such systems (the A4988 has an internal pull-up on its **SLEEP** pin). This 10k resistor is not present on the initial (md20a) version of the DRV8825 carrier. To keep faults from pulling down the **SLEEP** pin, any external pull-up resistor you add to the **SLEEP** pin input should not exceed 4.7k.

### Current limiting

To achieve high step rates, the motor supply is typically much higher than would be permissible without active current limiting. For instance, a typical stepper motor might have a maximum current rating of 1 A with a 5Ω coil resistance, which would indicate a maximum motor supply of 5 V. Using such a motor with 12 V would allow higher step rates, but the current must actively be limited to under 1 A to prevent damage to the motor.

The DRV8824 supports such active current limiting, and the trimmer potentiometer on the board can be used to set the current limit. You will typically want to set the driver's current limit to be at or below the current rating of your stepper motor. One way to set the current limit is to put the driver into full-step mode and to measure the current running through a single motor coil without clocking the STEP input. The measured current will be 0.7 times the current limit (since both coils are always on and limited to approximately 70% of the current limit setting in full-step mode).

Another way to set the current limit is to measure the voltage on the "ref" pin and to calculate the resulting current limit (the current sense resistors are 0.330Ω). The ref pin voltage is accessible on a via that is circled on the bottom silkscreen of the circuit board. The current limit relates to the reference voltage as follows:

Current Limit =  $V_{REF} \times 0.61$

So, for example, if you have a stepper motor rated for 0.5 A, you can set the current limit to 0.5 A by setting the reference voltage to 0.82 V.



Note: The coil current can be very different from the power supply current, so you should not use the current measured at the power supply to set the current limit. The appropriate place to put your current meter is in series with one of your stepper motor coils.

### Power dissipation considerations

The DRV8824 driver IC has a maximum current rating of 1.6 A per coil, but the current sense resistors further limit the maximum current to 1.2 A, and the actual current you can deliver depends on how well you can keep the IC cool. The carrier's printed circuit board is designed to draw heat out of the IC, but to supply more than approximately 0.75 A per coil, a heat sink or other cooling method is required.

This product can get **hot** enough to burn you long before the chip overheats. Take care when handling this product and other components connected to it.

Please note that measuring the current draw at the power supply will generally not provide an accurate measure of the coil current. Since the input voltage to the driver can be significantly higher than the coil voltage, the measured current on the power supply can be quite a bit lower than the coil current (the driver and coil basically act like a switching step-down power supply). Also, if the supply voltage is very high compared to what the motor needs to achieve the set current, the duty cycle will be very low, which also leads to significant differences between average and RMS currents. Additionally, please note that the coil current is a function of the set current limit, but it does not necessarily equal the current limit setting. The actual current through each coil changes with each microstep. See the DRV8824 datasheet for more information.

### Schematic diagram

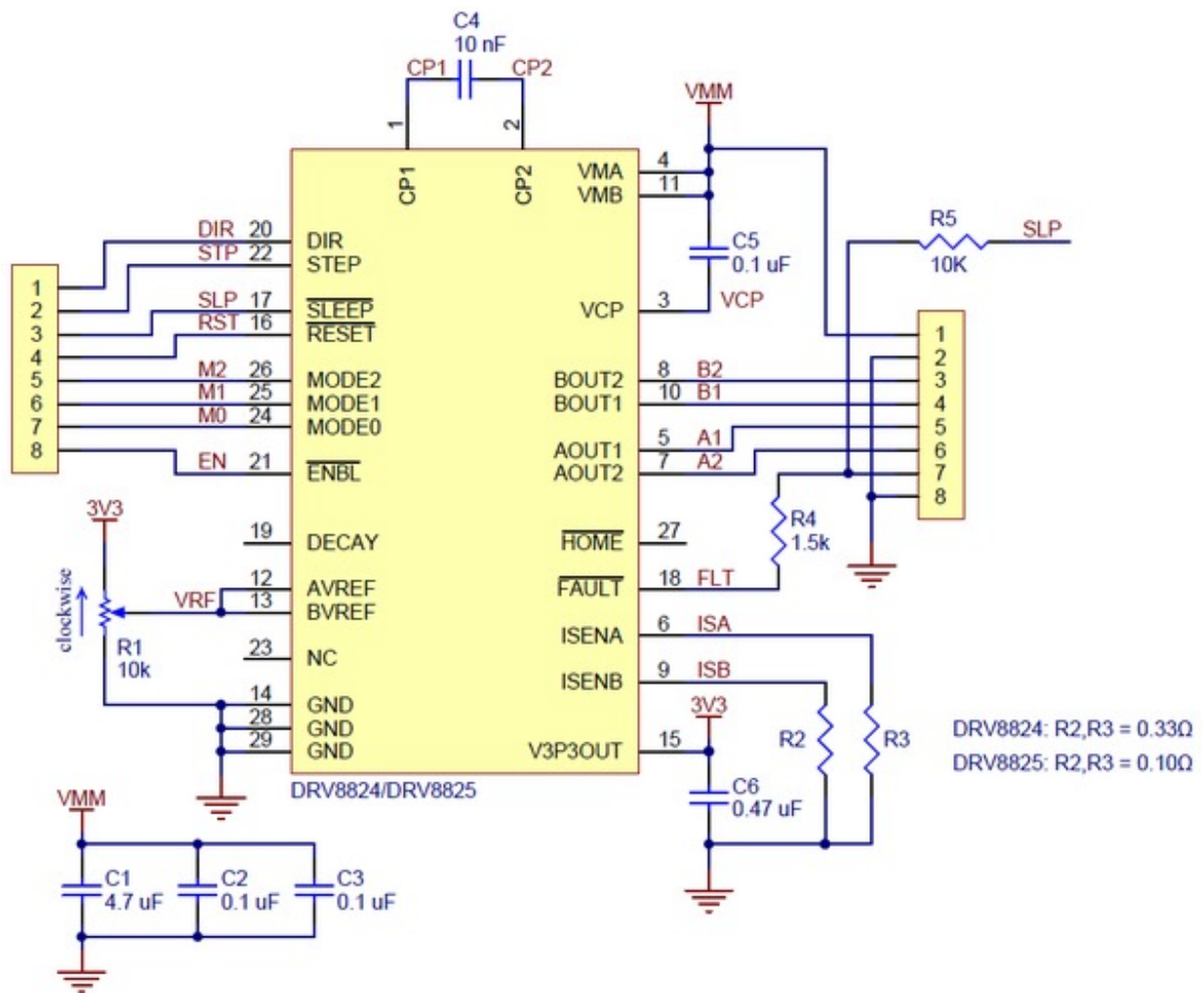

Schematic diagram for the DRV8824/DRV8825 stepper motor driver carrier.

The current sense resistors (R2 and R3) on the DRV8825 carrier are 0.330 Ω. This schematic is also available as a downloadable pdf (196k pdf).

### Key differences between the DRV8824 and A4988

The DRV8824 carrier was designed to be as similar to our A4988 stepper motor driver carriers as possible, and it can be used as a drop in replacement for the A4988 carrier in many applications

because it shares the same size, pinout, and general control interface. There are a few differences between the two modules that should be noted, however:

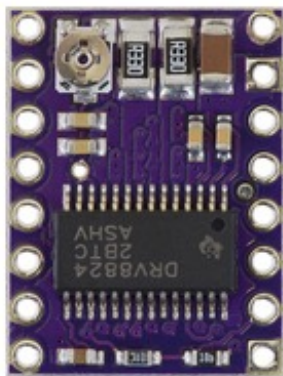

DRV8824 stepper motor driver carrier.

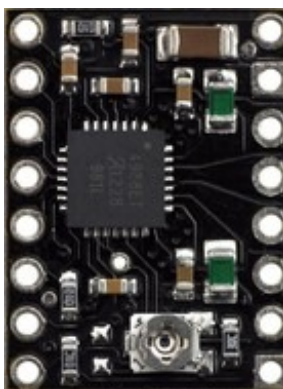

A4988 stepper motor driver carrier, Black Edition

- The pin used to supply logic voltage to the A4988 is used as the DRV8824's FAULT output, since the DRV8824 does not require a logic supply (and the A4988 does not have a fault output). Note that it is safe to connect the FAULT pin directly to a logic supply (there is a 1.5k resistor between the IC output and the pin to protect it), so the DRV8824 module can be used in systems designed for the A4988 that route logic power to this pin.
- The SLEEP pin on the DRV8824 is not pulled up by default like it is on the A4988, but the carrier board does connect it to the FAULT pin through a 10k resistor. Therefore, systems intended for the A4988 that route logic power to the FAULT pin will effectively have a 10k pull-up on the SLEEP pin. (This 10k resistor is not present on the initial (md20a) version of the DRV8825 carrier.)
- The current limit potentiometer is in a different location.
- The relationship between the current limit setting and the reference pin voltage is different.
- The DRV8824 offers 1/32-step microstepping; the A4988 only goes down to 1/16-step. Additionally, the DRV8824's larger current sense resistors allow for improved microstepping performance at low currents.
- The mode selection pin inputs corresponding to 1/16-step on the A4988 result in 1/32-step microstepping on the DRV8824. For all other microstepping resolutions, the step selection table is the same for both the DRV8824 and the A4988.
- The timing requirements for minimum pulse durations on the STEP pin are different for the two drivers. With the DRV8824, the high and low STEP pulses must each be at least 1.9 us; they can be as short as 1 us when using the A4988.



- The DRV8824 has a higher maximum supply voltage than the A4988 (45 V vs 35 V), which means the DRV8824 can be used more safely at higher voltages and is less susceptible to damage from LC voltage spikes.
- The DRV8824 cannot deliver as much current as the A4988.
- The DRV8824 uses a different naming convention for the stepper motor outputs, but they are functionally the same as the corresponding pins on the A4988 carrier, so the same connections to both drivers result in the same stepper motor behavior. On both boards, the first part of the label identifies the coil (so you have coils “A” and “B” on the DRV8824 and coils “1” and “2” on the A4988).
- For those with color-sensitive applications, note that the DRV8824 carrier is purple.

In summary, the DRV8824 carrier is similar enough to our A4988 carriers that the minimum connection diagram for the A4988 is a valid alternate way to connect the DRV8824 to a microcontroller as well:

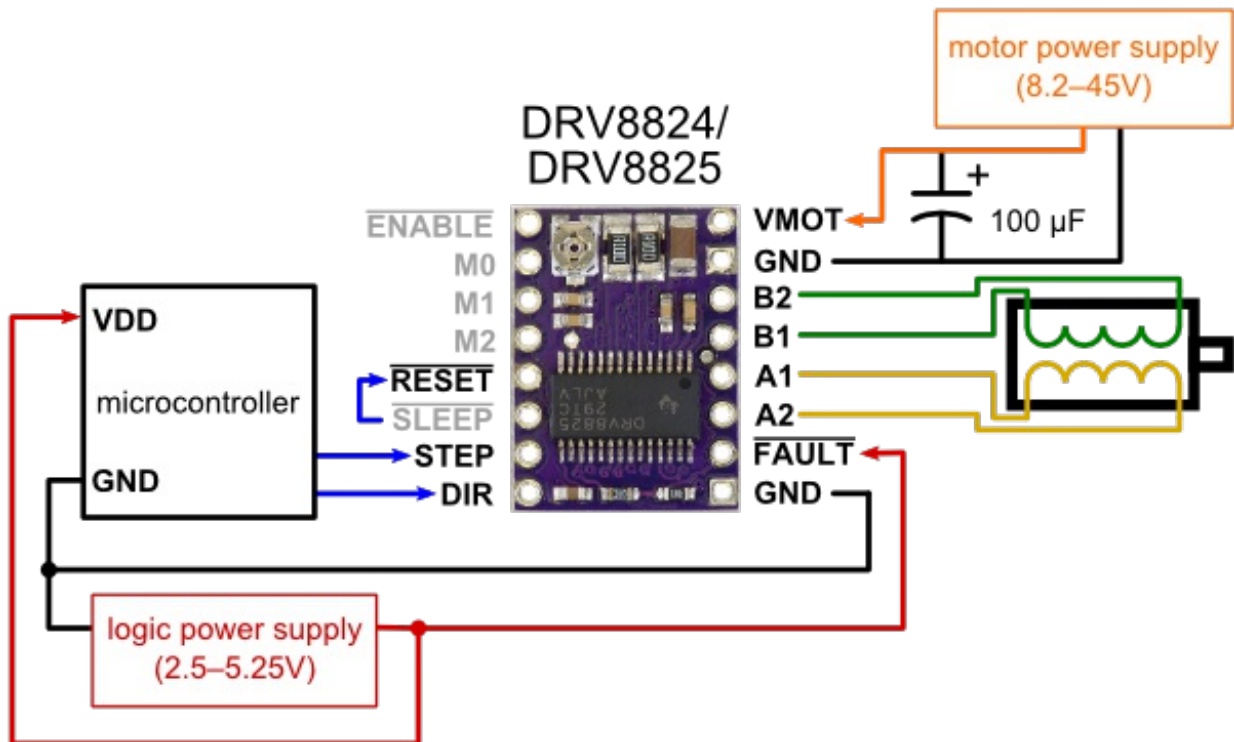

Alternative minimal wiring diagram for connecting a microcontroller to a DRV8824/DRV8825 stepper motor driver carrier (full-step mode).

[Documentation on producer website.](#)