



## 100:1 Metal Gearmotor 37Dx57L mm

### Overview

This powerful brushed DC gearmotor is available in six different gear ratios. Versions with an integrated quadrature encoder are also available, including just the motor and encoder portion by itself (no gearbox).

Gear Ratio	No-Load Speed@ 12 V	Stall Torque@ 12 V	Stall Current@ 12 V	 With Encoder	 Without Encoder
1:1	11,000 RPM	5 oz-in	5 A	motor without gearbox	
19:1	500 RPM	84 oz-in	5 A	37Dx52L mm	37Dx52L mm
30:1	350 RPM	110 oz-in	5 A	37Dx52L mm	37Dx52L mm
50:1	200 RPM	170 oz-in	5 A	37Dx54L mm	37Dx54L mm
70:1	150 RPM	200 oz-in	5 A	37Dx54L mm	37Dx54L mm
100:1	100 RPM	220 oz-in	5 A	37Dx57L mm	37Dx57L mm
131:1	80 RPM	250 oz-in	5 A	37Dx57L mm	37Dx57L mm

These motors are intended for use at 12 V, though the motor can begin rotating at voltages as low as 1 V.

### Details for item #1106

Exact gear ratio:  $(25 \times 30 \times 28 \times 28 \times 30) / (10 \times 10 \times 12 \times 12 \times 12) \approx (102.083:1)$

### Gearmotor Dimensions:

The face plate has six mounting holes evenly spaced around the outer edge threaded for M3 screws. These mounting holes form a regular hexagon and the centers of neighboring holes are 15.5 mm apart. You can use our custom 37D metal gearmotor bracket (shown in the left picture below) to mount the gearmotor to your project via these mounting holes and the screws that come with the bracket.

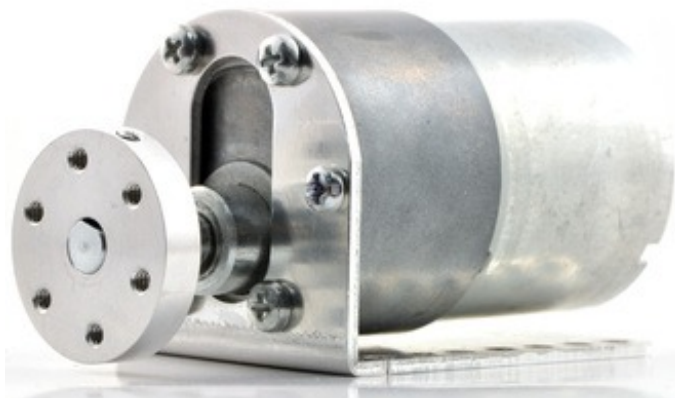

Gearmotor with bracket and hub.



Black Pololu 90x10mm wheel on a Pololu 37D mm metal gearmotor.

Please note that unlike our smaller metal gearmotors, these 37D mm gearmotors have output shafts with a diameter of 6 mm. The Pololu universal aluminum mounting hub for 6mm shafts can

be used to mount our larger Pololu wheels (80mm- and 90mm-diameter) or custom wheels and mechanisms to the gearmotor's output shaft (see the right picture above).

The picture below shows the dimensions (in mm) of the 37D mm line of gearmotors. The value of X is 22 mm for the 19:1 37Dx52L mm and 30:1 37Dx52L mm versions, 24 mm for the 50:1 37Dx54L mm and 70:1 37Dx54L mm versions, and 26.5 mm for the 100:1 37Dx57L mm and 131:1 37Dx57L mm versions.

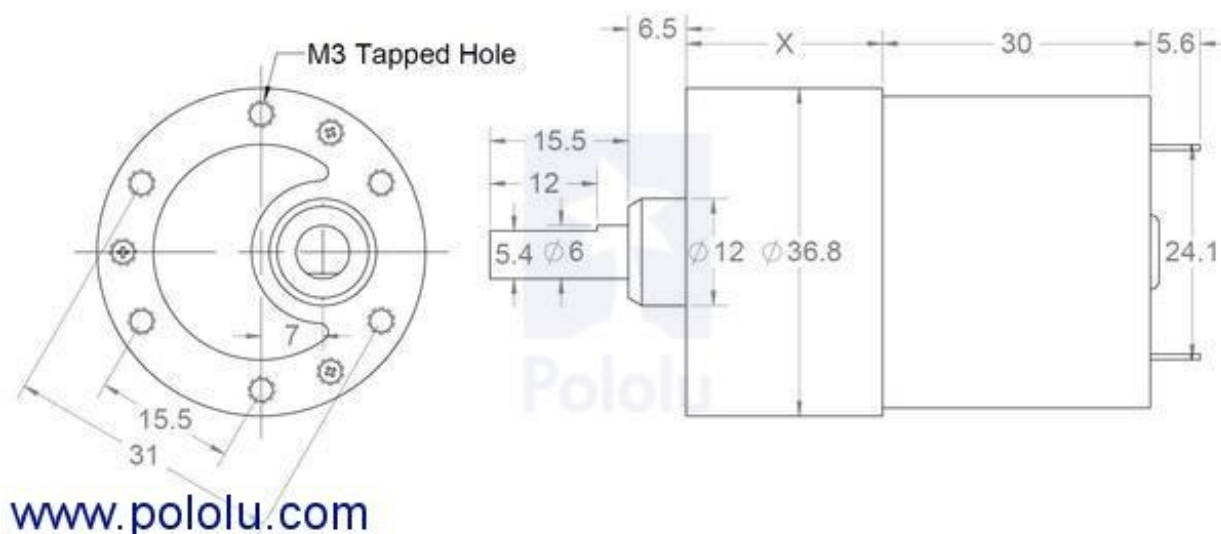

37D mm metal gearmotor dimensions (units in mm).

Warning: Do not screw too far into the mounting holes as the screws can hit the gears. We recommend screwing no further than 3mm (1/8") into the screw hole.

The operational specs listed in the table below were measured at 6 V. At 12 V, the no-load RPM, stall current, and stall torque will all be approximately twice their 6V values. To see the motor specs for 12V operation, please see the short description at the top of this page or this product's specification tab.



37D mm metal gearmotor next to a micro metal gearmotor for size comparison.

### Selecting the Right Gearmotor

We offer a wide selection of metal gearmotors that offer different combinations of speed and torque. Our metal gearmotor comparison table can help you find the motor that best meets your project's requirements.



[www.pololu.com](http://www.pololu.com)

Some of the Pololu metal gearmotors.

[Documentation on producer website.](#)