

ORG12XX SERIES GNSS RECEIVER MODULES

Datasheet

OriginGPS.com



INDEX

1.	SCOPE.....	4
2.	DISCLAIMER	4
3.	SAFETY INFORMATION	4
4.	ESD SENSITIVITY	4
5.	CONTACT INFORMATION	4
6.	RELATED DOCUMENTATION.....	4
7.	REVISION HISTORY	4
8.	GLOSSARY	5
9.	ABOUT ORG12XX SERIES	6
10.	ABOUT ORIGINGPS.....	6
11.	DESCRIPTION.....	7
11.1.	FEATURES.....	7
11.2.	ARCHITECTURE	8
12.	ELECTRICAL SPECIFICATIONS	10
12.1.	ABSOLUTE MAXIMUM RATINGS.....	10
12.2.	RECOMMENDED OPERATING CONDITIONS.....	11
13.	PERFORMANCE	12
13.1.	ACQUISITION TIMES.....	12
13.2.	SENSITIVITY	13
13.3.	POWER CONSUMPTION	13
13.4.	ACCURACY.....	13
13.5.	DYNAMIC CONSTRAINS	14
14.	POWER MANAGEMENT.....	14
14.1.	POWER STATES	14
15.	EXTENDED FEATURES	14
15.1.	JAMMER BARRIER	14
15.2.	AUTONOMOUS A-GPS.....	14
15.3.	PREDICTIVE A-GPS.....	14
16.	INTERFACE	15
16.1.	PAD ASSIGNMENT.....	15
16.2.	CONNECTIVITY	15
16.2.1.	POWER.....	15
16.2.2.	HOST CONTROL INTERFACE.....	16
16.2.3.	RF INPUT – ORG1208.....	17
16.2.4.	HOST DATA INTERFACE	17
16.2.5.	SENSORS INTERFACE	18
16.3.	TYPICAL APPLICATION CIRCUIT.....	19
17.	PCB LAYOUT	20
17.1.	FOOTPRINT.....	20
17.2.	DESIGN RESTRICTIONS	20
18.	OPERATION	21
18.1.	STARTING THE MODULE.....	21
18.2.	VERIFYING THE MODULE HAS STARTED	21
18.3.	SHUTTING DOWN THE MODULE	21
19.	SOFTWARE FUNCTIONS.....	21
19.1.	NMEA OUTPUT MESSAGES.....	21
19.2.	NMEA INPUT MESSAGES	21
20.	HANDLING INFORMATION	22
20.1.	PRODUCT PACKAGING AND DELIVERY.....	22
20.2.	MOISTURE SENSITIVITY	23
20.3.	ASSEMBLY	23
20.4.	REWORK.....	24
20.5.	ESD SENSITIVITY	24
20.6.	COMPLIANCES.....	24
20.7.	SAFETY INFORMATION	25



20.8.	DISPOSAL INFORMATION	25
21.	MECHANICAL SPECIFICATIONS	25
21.1.	ORG1218 MODULE.....	25
21.2.	ORG1208 MODULE.....	26

TABLE INDEX

TABLE 1 – RELATED DOCUMENTATION	4
TABLE 2 – REVISION HISTORY.....	4
TABLE 3 – ABSOLUTE MAXIMUM RATINGS	11
TABLE 4 – RECOMMENDED OPERATING CONDITIONS	12
TABLE 5 – ACQUISITION TIMES	12
TABLE 6 – SENSITIVITY.....	13
TABLE 7 – POWER CONSUMPTION.....	13
TABLE 8 – ACCURACY	13
TABLE 9 – DYNAMIC CONSTRAINS.....	14
TABLE 10 – ORG12XX SERIES MODULE PIN-OUT	15
TABLE 11 – SPI TIMING.....	18
TABLE 12 – NMEA PROTOCOL OUTPUT MESSAGES	21
TABLE 13 – NMEA PROTOCOL INPUT MESSAGES	21
TABLE 14 – REEL DIMENSIONS	23
TABLE 15 – ORG1218 MECHANICAL SUMMARY	25
TABLE 16 – ORG1208 MECHANICAL SUMMARY	26

FIGURE INDEX

FIGURE 1 – ORG1218 ARCHITECTURE	8
FIGURE 2 – ORG1208 ARCHITECTURE	9
FIGURE 3 – GNSS SoC FUNCTIONAL BLOCK DIAGRAM.....	10
FIGURE 4 – UART INTEGRITY	17
FIGURE 5 – SPI TIMING.....	18
FIGURE 6 – ORG1218 UART INTERFACE CIRCUIT	19
FIGURE 7 – ORG1208 UART INTERFACE CIRCUIT	19
FIGURE 8 – FOOTPRINT	20
FIGURE 9 – CARRIER.....	22
FIGURE 10 – CARRIER DIMENSIONS [mm].....	22
FIGURE 11 – MODULE POSITION	22
FIGURE 12 – REEL.....	23
FIGURE 13 – RECOMMENDED SOLDERING PROFILE	24
FIGURE 15 – ORG1208 MECHANICAL DRAWING	26



1. SCOPE

This document describes the features and specifications of Multi Hornet ORG1218 and Multi Hornetella ORG1208 GNSS Receiver Modules.

2. DISCLAIMER

All trademarks are properties of their respective owners.

Performance characteristics listed in this document do not constitute a warranty or guarantee of product performance. OriginGPS assumes no liability or responsibility for any claims or damages arising out of the use of this document, or from the use of integrated circuits based on this document.

OriginGPS assumes no liability or responsibility for unintentional inaccuracies or omissions in this document. OriginGPS reserves the right to make changes in its products, specifications and other information at any time without notice.

OriginGPS reserves the right to conduct, from time to time, and at its sole discretion, firmware upgrades. As long as those FW improvements have no material change on end customers, PCN may not be issued. OriginGPS navigation products are not recommended to use in life saving or life sustaining applications.

3. SAFETY INFORMATION

Improper handling and use can cause permanent damage to the product.

4. ESD SENSITIVITY

This product is ESD sensitive device and must be handled with care.



5. CONTACT INFORMATION

Support - info@origingps.com or [Online Form](#)

Marketing and sales - marketing@origingps.com

Web – www.origingps.com

6. RELATED DOCUMENTATION

No	DOCUMENT NAME
1	Micro Spider – ORG4475 Evaluation Kit Datasheet
2	Micro Spider – ORG4475 Product Change Notification
3	Spider and Hornet - Software User Manual for CSR® based receivers
4	Spider and Hornet - NMEA Protocol Reference Manual for CSR® based receivers
5	Spider and Hornet - One Socket Protocol Reference Manual for CSR® based receivers
6	Spider and Hornet - Host Interface Application Note
7	Spider and Hornet - Low Power Modes Application Note
8	Spider and Hornet - Jammer Detector and Remover Application Note

TABLE 1 – RELATED DOCUMENTATION

7. REVISION HISTORY

REVISION	DATE	CHANGE DESCRIPTION
A00	February 1, 2013	First release
2.0	January 14, 2015	Format update
3.0	January 19, 2015	Reel packaging quantities

TABLE 2 – REVISION HISTORY



8. GLOSSARY

A-GNSS Assisted GNSS
BPF Band Pass Filter
CE European Community conformity mark
CGEE™ Client Generated Extended Ephemeris
CMOS Complementary Metal-Oxide Semiconductor
COMPASS PRC GNSS (same as **BDS** BeiDou-2 Navigation Satellite System)
EGNOS European Geostationary Navigation Overlay Service
EMC Electro-Magnetic Compatibility
ESD Electro-Static Discharge
EVB Evaluation Board
EVK Evaluation Kit
FCC Federal Communications Commission
GALILEO EU GNSS
GLONASS Global Navigation Satellite System
GNSS Global Navigation Satellite System
GPS Global Positioning System
I²C Inter-Integrated Circuit
IC Integrated Circuit
ISO International Organization for Standardization
LDO Low Dropout regulator
LGA Land Grid Array
LNA Low Noise Amplifier
MSAS Multi-functional Satellite Augmentation System
MSL Moisture Sensitivity Level
NFZ™ Noise-Free Zones System
NMEA National Marine Electronics Association
MEMS MicroElectroMechanical Systems
PCB Printed Circuit Board
PPS Pulse Per Second
QZSS Quasi-Zenith Satellite System
REACH Registration, Evaluation, Authorisation and Restriction of Chemical substances
RF Radio Frequency
RHCP Right-Hand Circular Polarized
RoHS Restriction of Hazardous Substances directive
ROM Read-Only Memory
RTC Real-Time Clock
SAW Surface Acoustic Wave
SBAS Satellite-Based Augmentation Systems
SGEE™ Server Generated Extended Ephemeris
SIP System In Package
SMD Surface Mounted Device
SMT Surface-Mount Technology
SOC System On Chip
SPI Serial Peripheral Interface
TCXO Temperature-Compensated Crystal Oscillator
TTF Time To First Fix
TTL Transistor-Transistor Logic
UART Universal Asynchronous Receiver/Transmitter
WAAS Wide Area Augmentation System



9. ABOUT ORG12XX SERIES

The ORG12XX series module has been designed to address markets where an ability to autonomously acquire position fix from multiple satellite constellations must be coupled with superior sensitivity and low power consumption.

The ORG12XX series module is a miniature GNSS (Global Navigation Satellite System) GPS/GALILEO/GLONASS receiver that continuously tracks all satellites in view and provides real-time positioning data in industry's standard NMEA format.

The ORG12XX series module is able to decode extremely weak satellite signals simultaneously from GPS and GLONASS thereby offering best-in-class positioning availability, unparalleled accuracy and extremely fast fixes under challenging signal conditions, such as in built-up urban areas, dense foliage or even indoor.

Featuring OriginGPS proprietary Noise-Free Zone System™ technology the ORG12XX series module offers the ultimate in high sensitivity satellite navigation combined with high immunity.

The ORG12XX series module is a complete SiP (System-in-Package) featuring miniature SMD (Surface Mount Device) technology footprint designed to commit unique integration features for high volume, low power and cost sensitive applications.

Internal GNSS SoC (System-on-Chip) incorporating high-performance ARM9 microprocessor and sophisticated GNSS firmware keeps positioning payload off the host allowing integration in embedded solutions even with low computing resources.

The ORG12XX series incorporate 2 modules:

1. The ORG1218 – fully integrated GNSS module with on-board antenna. The ORG1218 GPS receiver module is pin and footprint compatible to the OriginGPS ORG1418 module.
2. The ORG1208 – fully integrated GNSS module with on-board RF connector. The ORG1208 GPS receiver module is pin and footprint compatible to the OriginGPS ORG1408 module.

10. ABOUT ORIGINGPS

OriginGPS is a world leading designer, manufacturer and supplier of miniature positioning modules, antenna modules and antenna solutions.

OriginGPS modules introduce unparalleled sensitivity and noise immunity by incorporating Noise Free Zone system (NFZ™) proprietary technology for faster position fix and navigation stability even under challenging satellite signal conditions.

Founded in 2006, OriginGPS is specializing in development of unique technologies that miniaturize RF modules, thereby addressing the market need for smaller wireless solutions.



11. DESCRIPTION

OriginGPS has researched and enhanced the performance of standard GPS receivers in real life applications. Case study of the specifications of key components through involvement in R&D effort of major vendors derived in highest performance in industry's smallest footprint parts available. These carefully selected key components resulted in higher sensitivity, faster position fix, navigation stability and operation robustness under rapid environmental changes creating hard-to-achieve laboratory performance in heavy-duty environment.

11.1. FEATURES

- + Autonomous operation
- + OriginGPS Noise Free Zone System (NFZ™) technology
- + Active antenna on-board – ORG1218
- + Active or passive antenna input – ORG1208
- + Fully integrated with:
 - + GNSS SAW Filter, GNSS LNA, TCXO, RTC Crystal, RF Shield, RAM, Flash Memory,
 - + Power Management Unit
- + 50Ω miniature RF connector, Load Switch – ORG1208
- + GPS/GLONASS/GALILEO/COMPASS1 multi-GNSS RF and Baseband
- + SBAS (WAAS, EGNOS, MSAS, QZSS) support
- + 32 tracking channels
- + Sensitivity: -162dBm during Tracking
- + TTFF: < 1s under Hot Start conditions
- + Accuracy: < 1.5m CEP (50%)
- + Timing Accuracy: < 30ns
- + Update rate: up to 10Hz
- + Autonomous A-GPS for non-networked devices
- + Predictive A-GPS for connected devices
- + Jammer Barrier through proprietary filtering and removal
- + Low power mode: < 0.1mW during Backup state
- + ARM9 208MHz microprocessor system
- + UART or SPI host interface
- + Programmable baud rate and messages rate
- + Secondary UART for RTCM-104
- + Auxiliary I²C bus for MEMS sensors
- + Single voltage supply: 3 – 3.6V
- + Backup supply option: 1.6 – 3.6V
- + Small footprint: 17mm x 17mm
- + Surface Mount Device (SMD)
- + Operating temperature range: -40°C to 85°C



- + FCC and CE certified
- + Pb-Free RoHS/REACH compliant
- + ISO/TS 16949 manufacturing standard

Notes: 1. Future modification

11.2. ARCHITECTURE

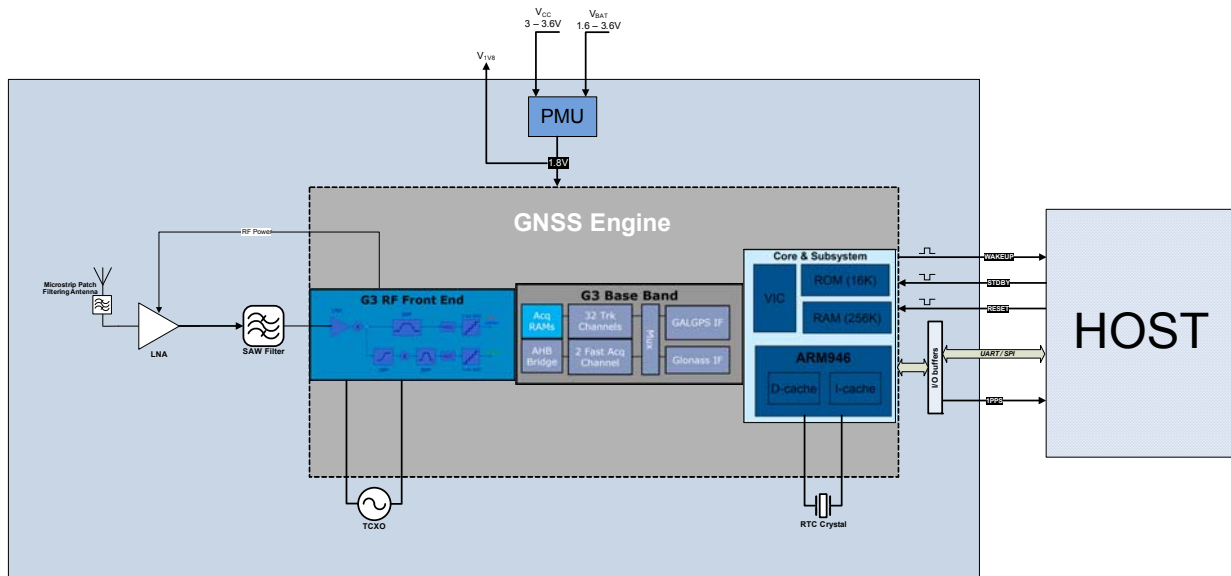

FIGURE 1 – ORG1218 ARCHITECTURE

+ Microstrip Patch Antenna

OriginGPS integrated microstrip patch antenna element collects GNSS signals from the medium.

+ GNSS LNA (Low Noise Amplifier)

The integrated LNA amplifies the GNSS signal to meet RF down converter input threshold.

Noise Figure optimized design was implemented to provide maximum sensitivity.

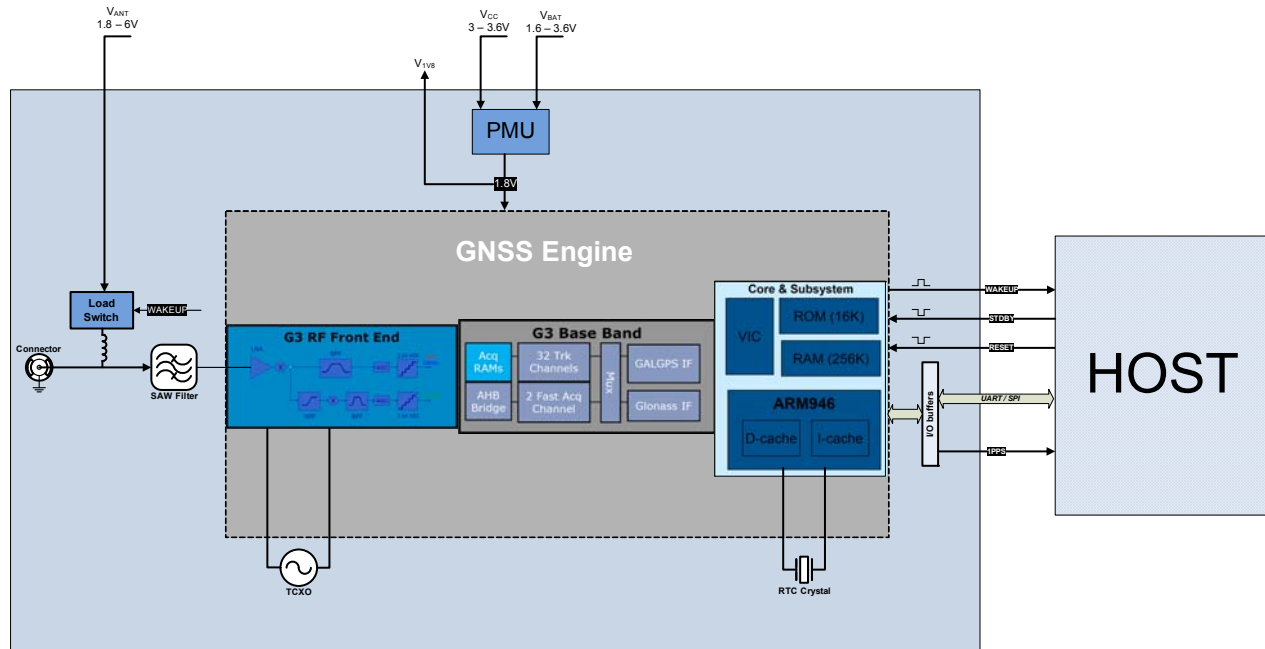

FIGURE 2 – ORG1208 ARCHITECTURE

+ Antenna Connector

Signals from the GNSS satellites are being delivered from receiving antenna through W.FL® standard miniature coaxial connector.

+ Load Switch

Load switch provides control over DC bias voltage supply for active antenna. When the ORG1208 module is in Standby or Backup state no power is dissipated on active antenna.

+ GNSS SAW (Surface Acoustic Wave) Filter

Band-Pass SAW filter eliminates out-of-band signals that may interfere to GNSS reception.

+ Voltage Regulator

Voltage regulator provides stable supply for GNSS RF front-end.

The design of this block was optimized for low ripple, low quiescent current and high PSRR.

+ TCXO (Temperature Compensated Crystal Oscillator)

Highly stable 26 MHz oscillator controls the down conversion process in RF block of the GNSS SoC.

Characteristics of this component are important factors for higher sensitivity, shorter TTFF and better navigation stability.

+ RTC (Real Time Clock) crystal

Tuning fork quartz crystal with very tight specifications is necessary for maintaining Hot Start and Warm Start capabilities of the module.

+ RF Shield

RF enclosure avoids external interference from compromising sensitive circuitry inside the module. RF shield also blocks module’s internal high frequency emissions from being radiated.



+ GNSS SoC

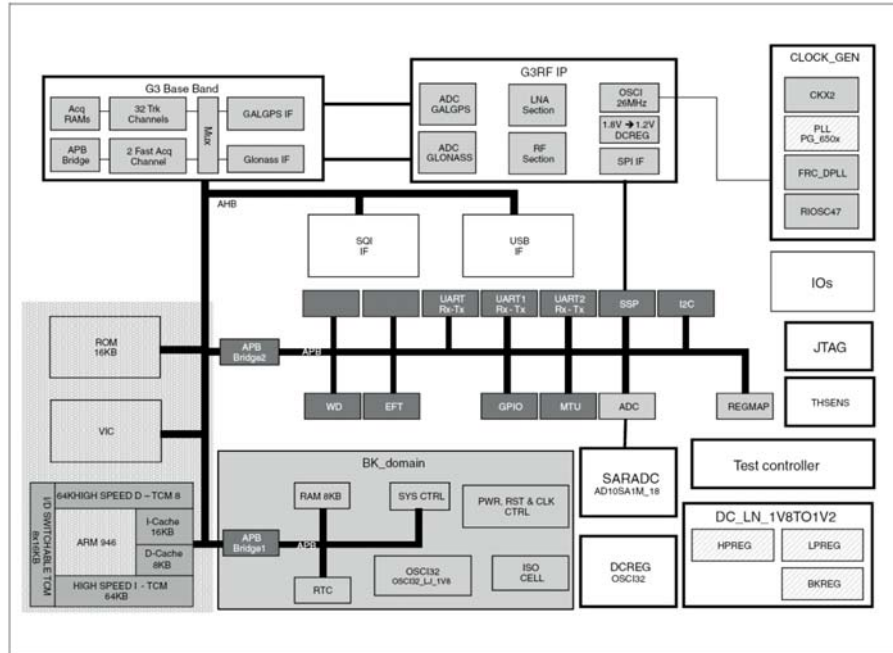

FIGURE 3 – GNSS SoC FUNCTIONAL BLOCK DIAGRAM

The GNSS SoC includes the following main units:

- + GNSS RF block incorporating LNA, dual down converter and fractional-N synthesizer
- + GNSS IF block incorporating dual IF BPF centered on 4.092MHz for GPS/GALILEO signals and on 8.57MHz for GLONASS signals, and dual ADC with 3-bit quantization
- + Microprocessor system incorporating 208MHz ARM946 core and Vector Interrupted Controller
- + Flash memory block of 16Mbit for firmware storage
- + RAM block of 256KB for data cache
- + RTC block
- + UART block
- + SPI block
- + Power control block for internal voltage domains management

12. ELECTRICAL SPECIFICATIONS

12.1. ABSOLUTE MAXIMUM RATINGS

Absolute Maximum Ratings are stress ratings only.

Stresses exceeding Absolute Maximum Ratings may damage the module.

Parameter	Symbol	Min	Max	Units
Power Supply Voltage	VCC	-0.3	+3.63	V
Backup Supply Voltage	VBAT	-0.3	+3.63	V



Antenna Supply Voltage	ORG1208	VANT	-0.5	+6.0	V
Antenna Supply Current		IANT	-	200	mA
I/O Voltage		VIO	-0.3	+3.6	V
I/O Source/Sink Current		IIO	-2	+2	mA
1.8V Source Current		I1V8	-	20	mA
RF Input Power	f _{IN} = 1570MHz±1620MHz	PRF_IN	-	-10	dBm
	f _{IN} < 1525MHz		-	+25	
	f _{IN} > 1670MHz		-	+25	
ESD Rating	All pads	V(ESD)	-1	+1	kV
Power Dissipation		PD	-	300	mW
Storage temperature		TST	-55	+125	°C
Lead temperature (10 sec. @ 1mm from case)		TLEAD	-	+260	°C

TABLE 3 – ABSOLUTE MAXIMUM RATINGS

12.2. RECOMMENDED OPERATING CONDITIONS

Functional operation above the Recommended Operating Conditions is not implied.

Extended exposure to stresses above the Recommended Operating Conditions may affect module reliability.

Parameter	Symbol	Operation/Pad	Mode	Test	Min	Typ	Max	Units
Power Supply Voltage	VCC	VCC			3.0	3.3	3.6	V
Power Supply Current	ICC	Acquisition	GPS	-130dBm Outdoor VCC = 3.3V TAMB = 25°C		55		mA
			GPS+GLONASS			75		mA
		Tracking	GPS			35		mA
			GPS+GLONASS			55		mA
		Standby				1		mA
Backup Supply Voltage	VBAT	VBAT			1.6		3.6	V
Backup Supply Current	IBAT	Acquisition		VBAT = 1.8V TAMB = 25°C		1		mA
		Tracking				1		mA
		Standby				60		µA
		Backup				60		µA
Antenna Supply Voltage	VANT	VANT			1.8		5.5	V
Antenna Supply Current	IANT	VANT					100	mA
1.8V Output Voltage	V1V8	V1V8			1.77	1.80	1.83	V
1.8V Output Current	I1V8	V1V8					20	mA
Input Voltage Low State	VIL	UART / SPI			-0.3		+0.8	V
		RESET, STANDBY			-0.3		+0.48	V
Input Voltage High State	VIH	UART / SPI			+2.0		+3.6	V
		RESET, STANDBY			+0.8		+1.2	V



Output Voltage Low State	VOL	UART/SPI/1PPS					+0.4	V
		WAKEUP					+0.2	V
Output Voltage High State	VOH	UART/SPI/1PPS			+2.9		3.2	V
		WAKEUP			+1.0			V
Input Leakage Current	IIN(leak)	UART / SPI			-10		10	μA
Output Leakage Current	IOUT(lea)	UART/SPI/1PPS			-10		+10	μA
Input Capacitance	CIN	All pads				7		pF
Input Impedance	ZIN	RF Input	f0 = 1575.5 MHz			50		Ω
Input Return Loss	RLIN					-10		dB
Operating Temperature	TAMB				-40	+25	+85	°C
Relative Humidity	RH			-40°C	5		95	%

TABLE 4 – RECOMMENDED OPERATING CONDITIONS

13. PERFORMANCE

13.1. ACQUISITION TIMES

TTFF (Time To First Fix) – is the period of time from the module power-up till valid navigation solution.

Hot Start

Hot Start results from software reset after a period of continuous navigation or a return from a short idle period that was preceded by a period of continuous navigation.

During Hot Start all critical data (position, velocity, time, and satellite ephemeris) is valid to the specified accuracy and available in RAM.

Warm Start

Warm Start typically results from user-supplied position and time initialization data or continuous RTC operation with an accurate last known position available in RAM.

In this state, position and time data are present and valid, but ephemeris data validity has expired.

Cold Start

Cold Start acquisition results when satellite ephemeris, last good position and time data are unknown.

Aided Start

Aided Start is a method of effectively reducing the TTFF by making every start Hot or Warm.

		TTFF	Test Condition	Signal Level
Hot Start		< 1s	Outdoor	-130dBm
Aided Start1		< 10s		
Warm Start	GPS	< 34s		
	GPS+GLONASS	< 31s		
Cold Start	GPS	< 35s		
	GPS+GLONASS	< 33s		
Signal Reacquisition		< 1s		

TABLE 5 – ACQUISITION TIMES



13.2. SENSITIVITY

Operation	Signal Level
Tracking	-162 dBm
Navigation	-160 dBm (Deep)
Aided	-155 dBm
Cold Start	-146 dBm

TABLE 6 – SENSITIVITY

13.3. POWER CONSUMPTION

Operation	Mode	Power Consumption
Acquisition	GPS	180mW
	GPS+GLONASS	245mW
Tracking	GPS	115mW
	GPS+GLONASS	180mW
Standby	-	3mW
Backup	-	0.1mW

TABLE 7 – POWER CONSUMPTION

13.4. ACCURACY

		Method	Mode	Accuracy	Test Condition	Signal Level
Position	Horizontal	CEP (50%)	GPS	< 2.5m	Outdoor, 24-hr static	-130dBm
			GPS+SBAS	< 2m		
			GPS+GLONASS	< 1.5m		
		2dRMS (95%)	GPS	< 5m		
			GPS+SBAS	< 4m		
			GPS+GLONASS	< 3m		
	Vertical	VEP (50%)	GPS	< 4m		
			GPS+SBAS	< 3.5m		
			GPS+GLONASS	< 2.5m		
		2dRMS (95%)	GPS	< 7.5m		
			GPS+SBAS	< 6.5m		
			GPS+GLONASS	< 5m		
Velocity	Horizontal	50%		< 0.01m/s	Outdoor, 30m/s	-130dBm
Heading		50%		< 0.010	Outdoor, 30m/s	-130dBm
Time		1 PPS		< 40ns	Outdoor, 24-hr static	-130dBm

TABLE 8 – ACCURACY



13.5. DYNAMIC CONSTRAINS

	MAXIMUM	
Velocity	515 m/s	1,000 knots
Acceleration	4g	
Altitude	18,288 m	60,000 ft.

TABLE 9 – DYNAMIC CONSTRAINS

14. POWER MANAGEMENT

14.1. POWER STATES

Full Power state (Acquisition/Tracking)

The module stays in full power until a position solution is made and estimated to be reliable.

During the acquisition, processing is more intense than during tracking, thus consuming more power.

Standby state

In this state the RF block of the module is powered off and baseband clock is stopped.

During Standby state all outputs are in high-impedance state.

Backup state

In this state the RF block and the baseband block are completely powered off leaving only the RTC block running and Battery-Backed RAM sustained.

Upon exit Backup state of duration less than 4 hours since last valid navigation solution the ORG12XX series module will perform Hot Start acquisition trial.

15. EXTENDED FEATURES

15.1. JAMMER BARRIER

Jamming detection is processed by frequency spread and analysis of correlation results and jamming contribution calculation.

Jamming detector is effective only against continuous narrow band interference signals.

Jamming removal is done by dynamic notch filter alignment over GPS/GALILEO and GLONASS frequency bands.

Jamming remover has programmable notch filter central frequency and bandwidth.

15.2. AUTONOMOUS A-GPS

Autonomous A-GPS allows shorter TTFF by providing predicted (synthetic) ephemeris data created within a lost host system from previously received broadcast ephemeris.

Autonomous A-GPS is capable for up to 5-day span prediction.

15.3. PREDICTIVE A-GPS

Predictive A-GPS allows shorter TTFF by using a model downloaded from server.

Predictive A-GPS is suitable for networked applications, while communication channel is immaterial.

Predictive A-GPS is capable for up to 7-day span prediction.



16. INTERFACE

16.1. PAD ASSIGNMENT

Pad	Name	Description	Direction	Full Power	Standby	Backup	Notes
1	RX	UART Receive	Input	High	Hi-Z	Keep Low	2.0V – 3.6V
2	TX	UART Transmit	Output	High	Hi-Z	Keep Low	3.3V
3	VBAT	Secondary Power	Power	On	On	On	1.6V – 3.6V
4	SCK	SPI Clock	Input	Low	Hi-Z	Keep Low	2.0V – 3.6V
5	\overline{CS}	SPI Chip Select	Input	High	Hi-Z	Keep Low	
6	SDO	SPI Data Out	Output	High	Hi-Z	Keep Low	3.3V compatible
7	VANT	Active Antenna Bias	Power				Leave floating on ORG1218 or on ORG1208 with passive antenna
8	VCC	System Power	Power	On	On	Off	3.0V – 3.6V
9	V1V8	1.8V Source	Power	On	On	Off	Do not power this pad.
10	GND	System Ground	Power				
11	GND	System Ground	Power				
12	GND	System Ground	Power				
13	GND	System Ground	Power				
14	GND	System Ground	Power				
15	WAKEUP	Power Status	Output	High	Low	Low	1.2V compatible
16	\overline{RESET}	Asynchronous Reset	Input	High	High	Low	Do not drive
17	STANDBY	Power State Control	Input	High	Low	Low	Do not drive
18	DR_SDA	I ² C Serial Data / RTCM RX	Bi-dir	High	Hi-Z	Keep Low	3.3V compatible
19	DR_SCL	I ² C Serial Clock / RTCM TX	Output	High	Hi-Z	Keep Low	
20	ADC	ADC / Odometer input	Input			Keep Low	0V – 1.8V
21	1PPS	UTC Time Mark	Output	Low	Hi-Z	Keep Low	3.3V compatible
22	SDI	SPI Data In	Input	High	Hi-Z	Keep Low	2.0V – 3.6V

TABLE 10 – ORG12XX SERIES MODULE PIN-OUT

16.2. CONNECTIVITY

16.2.1. POWER

The ORG12XX series module can be operated from single unregulated power source, i.e. supplied directly from a battery, since the module has internal voltage converters.

Main power

VCC power input is for main power supply.

VCC power supply range is 3V to 3.6V DC.

Typical VCC is 3.3V.

Power supply current consumption varies according to the processor load and satellite acquisition.

Typical ICC current is 55mA during acquisition. Peak ICC current is 75 mA.

Voltage ripple below 50mVP-P allowed for frequency between 100KHz and 3MHz.

Higher voltage ripple may compromise the module's sensitivity performance.



Backup power

VBAT power input is for backup power supply.

VBAT power supply range is 1.6V to 3.6V DC.

Typical IBAT current in Backup state is 60 μ A.

Typical IBAT current in Full Power state is 1mA.

It is recommended to keep the VBAT power supply on all the time in order to maintain GNSS SoC RTC block active and RAM sustained for fastest possible TTF under Hot Start or Warm Start definitions.

When the VBAT is off prior to consecutive power-up, GNSS data and clock are discarded, configuration settings are reset to factory default, and the receiver performs Cold Start. While an application requires continuous navigation VBAT may be externally connected to VCC. During Hibernate state VBAT may be powered either by battery, or by super capacitor.

Antenna power – ORG1208

VANT power input is for active antenna bias through integrated low-loss load switch.

VANT power supply range is 1.8V to 5.5V DC according to antenna specifications.

Maximum IANT current is 150mA.

Antenna bias is internally controlled by the GNSS SoC and switched off during Standby or Backup states.

VANT may be externally connected to VCC, while module and antenna are in same voltage domain.

While using passive antenna, do not apply voltage on this input.

1.8V power source

V1V8 power supply provides regulated 1.8V voltage source.

Maximum I1V8 continuous output current is 20mA.

Ground

All Ground pads should be connected to the main Ground plane by shortest possible traces or multiple vias.

16.2.2. HOST CONTROL INTERFACE

STANDBY input

STANDBY control input is used to switch the receiver from Full Power into Standby state.

A logic low level applied on this input transfers and holds the module in Standby state.

A release of this input from logic low level exits the Standby state back to Full Power.

STANDBY input is active low and has internal pull-up resistor of 10k Ω .

Do not drive this input high. Do not connect if not in use.

RESET input

The Power-On-Reset (POR) is generated internally in the module when VBAT is applied.

Manual reset option is available through $\overline{\text{RESET}}$ pad.

$\overline{\text{RESET}}$ input should be asserted externally during the first power-up when VBAT power supply is applied prior to VCC power supply.

$\overline{\text{RESET}}$ input asserted during the operation clears the RTC block and discards configuration settings.

$\overline{\text{RESET}}$ signal should be logical low level for at least 1 μ s.

$\overline{\text{RESET}}$ input is active low and has internal pull-up resistor of 10k Ω .

Do not drive this input high. Do not connect if not in use.

WAKEUP output

WAKEUP output is used to flag the power state of the module.

A logical low level on this output indicates that the module is in Standby or Backup state.



A logical high level on this output indicates that the module is in Full Power state. In addition WAKEUP output can be used to control auxiliary devices. Wakeup output is LVCMOS 1.2V compatible. Do not connect if not in use.

1PPS output

The pulse-per-second (PPS) output provides a pulse signal for timing purposes. The rising edge of the 1PPS output signal is synchronized to full UTC second with <30ns accuracy. Typical RMS jitter on the rising edge of the 1PPS output signal is <30ns. Default pulse length (high state) is 500ms. By default, the UTC time output message is generated after 1PPS rising edge. The exact time between the 1PPS and UTC time message output depends on message rate, message queue and communication baud rate. Pulse length, polarity and phase are configurable by an NMEA input command. 1PPS output is LVCMOS 3.3V compatible. Do not connect if not in use.

16.2.3. RF INPUT – ORG1208

The ORG1208 module supports active and passive antennas. The antenna input impedance is 50Ω. DC bias voltage for active antennas is provided via VANT pad. Mating plug for RF antenna connector is Hirose W.FL , I-PEX MHF III or Sunridge MCD series. Recommended active antenna NF ≤ 1.8 dB, net gain excluding cable loss 10dB ≤ G ≤ 25dB. Leave VANT pad floating while using passive antenna. Contact OriginGPS for passive antenna selection.

16.2.4. HOST DATA INTERFACE

The ORG12XX series module has 2 types of interface ports to connect to host: UART and SPI.

UART

The module has a 2-wire UART port:

- + TX used for GPS data reports. Output logic high voltage level is LVCMOS 3.3V.
- + RX used for control over receiver configuration. Input logic high voltage level is 2V to 3.6V.

Operation:

The UART performs bit-by-bit transmitting and receiving in 8-bit octets when module is active. On the transmit side 1 start bit, 8 data bits and 1 stop bit followed by next character or idle line. On the receive side 1 start bit, 8 data bits, 1 stop bit or longer is accepted.

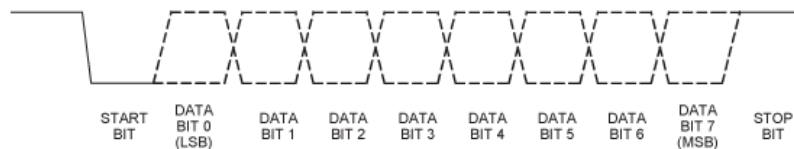

FIGURE 4 – UART INTEGRITY

Because UART transmission is asynchronous and sampled by the receiver, both sides require closely match bit-rate clocks, and that data bit waveform and timing distortion at the receiver should be limited.

The default protocol is NMEA@115,200bps.

The baud rate and message configuration can be changed by an input command.

SPI

The SPI (Serial to Peripheral Interface) is a master/slave synchronous serial bus that consists of 4 signals:

- + Serial Clock (SCK) from master to slave.
- + Serial Data Out (also called Master Out Slave In or MOSI) from master.



- + Serial Data In (also called Master In Slave Out or MISO) from slave.
- + Chip Select (CS) from master.

The host interface SPI of the module is a slave mode SPI.

Output logic high voltage level is LVCMOS 3.3V. Inputs are 3.6V tolerant.

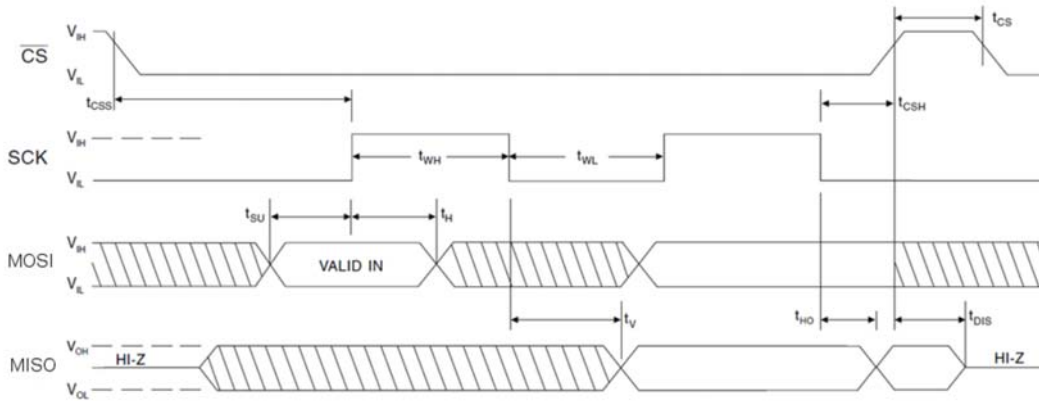

FIGURE 5 – SPI TIMING

Symbol	Parameter	Min	Max	Units
tCLK	SCK Time Period	TBA		ns
tCSS	nCS Setup Time	TBA	TBA	tCLK
tCS	nCS High Time	TBA	TBA	tCLK
tWH	SCK High Time	TBA	TBA	tCLK
tWL	SCK Low Time	TBA	TBA	tCLK
tCSH	nCS Hold Time	TBA	TBA	tCLK
tSU	Data In Setup Time	TBA	TBA	tCLK
tH	Data In Hold Time	TBA	TBA	tCLK
tV	Output Valid	TBA	TBA	tCLK
tHO	Output Hold Time	TBA	TBA	tCLK
tDIS	Output Disable Time	TBA	TBA	tCLK

TABLE 11 – SPI TIMING

16.2.5. SENSORS INTERFACE

Dead Reckoning (DR) I²C bus

The ORG12XX series module master mode I²C interface provides support for Dead Reckoning. This auxiliary bus has 2 lines, DR_SCL and DR_SDA, both are pseudo open-drain and require external pull-up resistors.

The interface supports required sensor instruments for dead reckoning applications such as gyros, accelerometers, compasses or other sensors that can be operated over the I²C bus. The Dead Reckoning (DR) algorithms perform a sensor data fusion with the satellite signal measurements.

Do not connect to this bus if the feature is not in use.

ADC / Odometer input

The ORG12XX series module can be programmed to use a dedicated GPIO either as odometer ticking counter, or as Analog-to-Digital Converter (ADC).

ADC specifications are: 10-bit SAR, 1MSPS, effective full scale voltage range 0V – 1.4V.

Do not connect to this input if the feature is not in use.

16.3. TYPICAL APPLICATION CIRCUIT

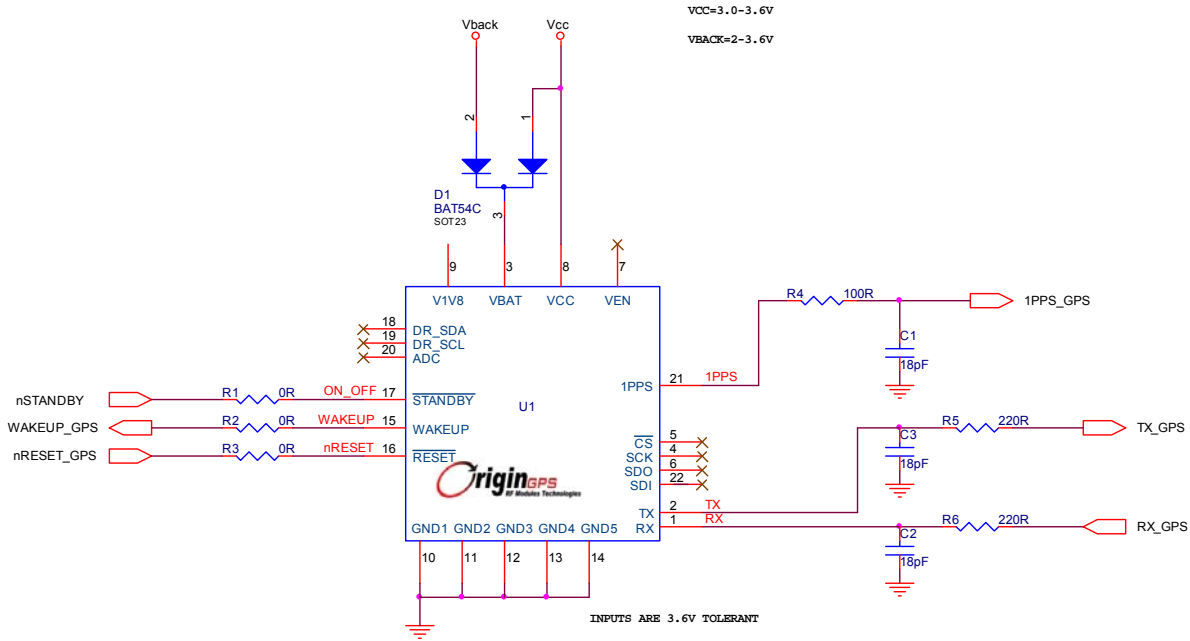

FIGURE 6 – ORG1218 UART INTERFACE CIRCUIT

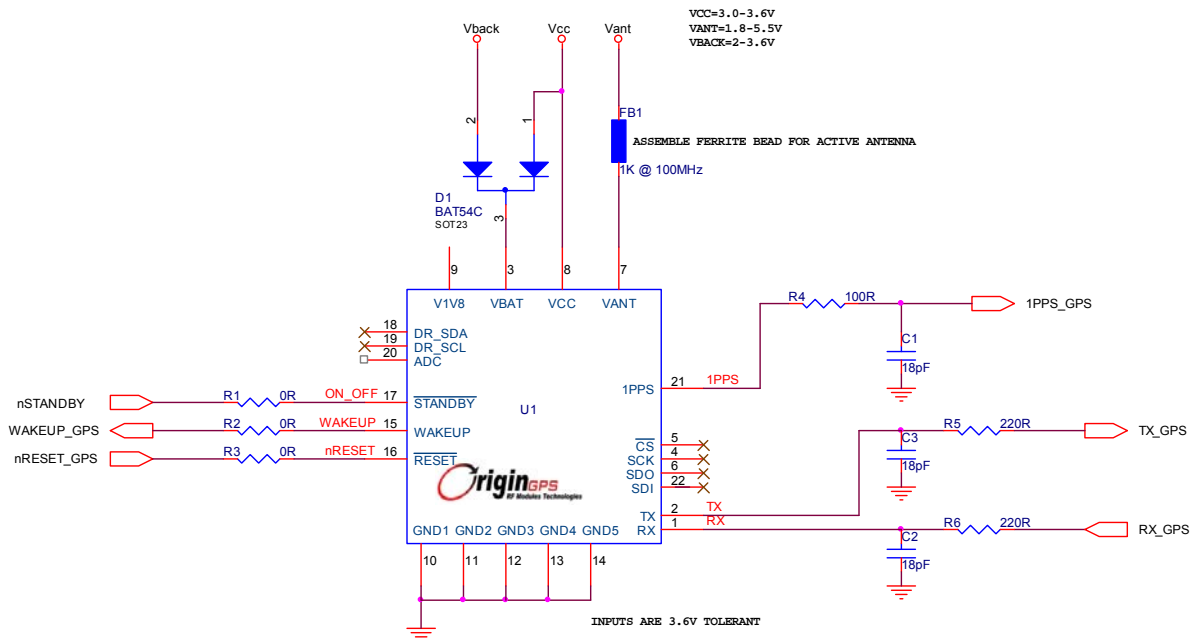

FIGURE 7 – ORG1208 UART INTERFACE CIRCUIT



17. PCB LAYOUT

17.1. FOOTPRINT

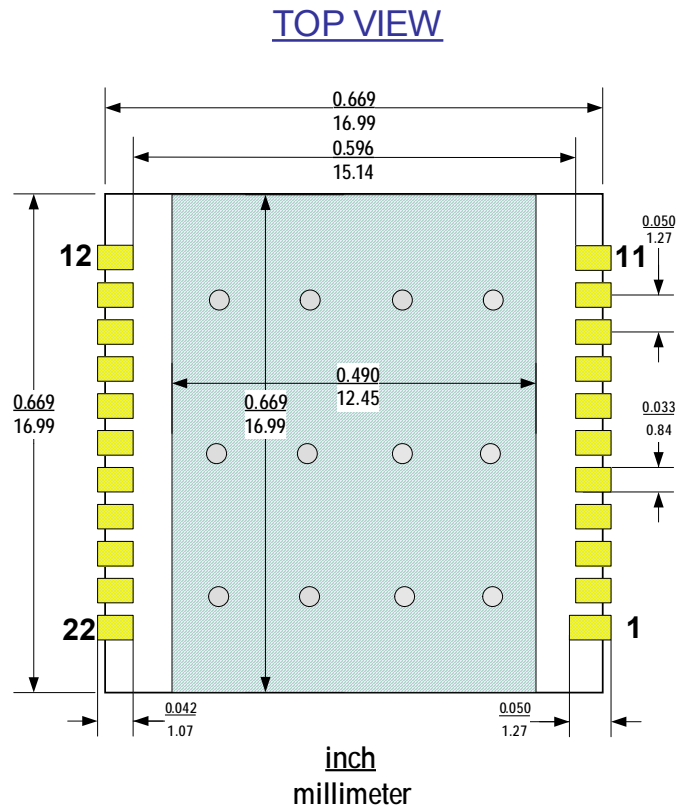

FIGURE 8 – FOOTPRINT

Ground pad at the middle should be connected to main Ground plane by multiple vias.

Ground pad at the middle should be solder masked.

Silk print of module's outline is highly recommended for SMT visual inspection.

17.2. DESIGN RESTRICTIONS

Keep out of signal or switching power traces and vias under the ORG12XX series module.

Signal traces to/from ORG12XX series module should have minimum length.

Recommended distance from adjacent active components is 3mm.

In case of adjacent high speed components, like CPU or memory, high frequency components, like transmitters, clock resonators or oscillators, metal planes, like LCD or battery enclosures, please contact OriginGPS for more precise, application specific recommendations.



18. OPERATION

18.1. STARTING THE MODULE

When power is first applied, the GNSS SoC of the module access boot-loader for firmware initialization. Firmware is executed autonomously, and the module starts searching for GNSS satellites.

18.2. VERIFYING THE MODULE HAS STARTED

- ✚ The module WAKEUP output will go logic level high indicating the GNSS SoC has started.
- ✚ The module will output standard NMEA strings starting '\$' at 115,200bps. baud rate.

18.3. SHUTTING DOWN THE MODULE

Transferring the module into Backup state can be forced by main VCC power supply removal.

19. SOFTWARE FUNCTIONS

The module supports standard NMEA-0183 protocol with proprietary extensions.

19.1. NMEA OUTPUT MESSAGES

Message	Description
\$GPRMC	Time, date, position, course and speed data in GPS mode or in GLONASS+GPS mode
\$GPGGA	Time, position and fix type data in GPS mode or in GLONASS+GPS modes
\$GPVTG	Course and ground speed data in GPS mode or in GLONASS+GPS mode
\$GPGSV	GPS satellite in view, SV ID, Elevation, Azimuth and SNR value
\$GLGSV	GLONASS satellite in view, SV ID, Elevation, Azimuth and SNR value
\$GPGSA	GPS operating mode, satellites used in the position solution and DOP values
\$GNGSA	GLONASS operating mode, satellites used in the position solution and DOP values
\$PTSTMSBAS	SBAS satellite in view, SV ID, Elevation, Azimuth and SNR value

TABLE 12 – NMEA PROTOCOL OUTPUT MESSAGES

19.2. NMEA INPUT MESSAGES

Message ID	Message
\$PSTMSETPAR	Proprietary Message
\$PSTMGETPAR	Proprietary Message
\$PSTMRESTOREPAR	Proprietary Message
\$PSTM COLD	Proprietary Message
\$PSTM	Proprietary Message
\$PSTM	Proprietary Message
\$PSTM	Proprietary Message

TABLE 13 – NMEA PROTOCOL INPUT MESSAGES



20. HANDLING INFORMATION

20.1. PRODUCT PACKAGING AND DELIVERY

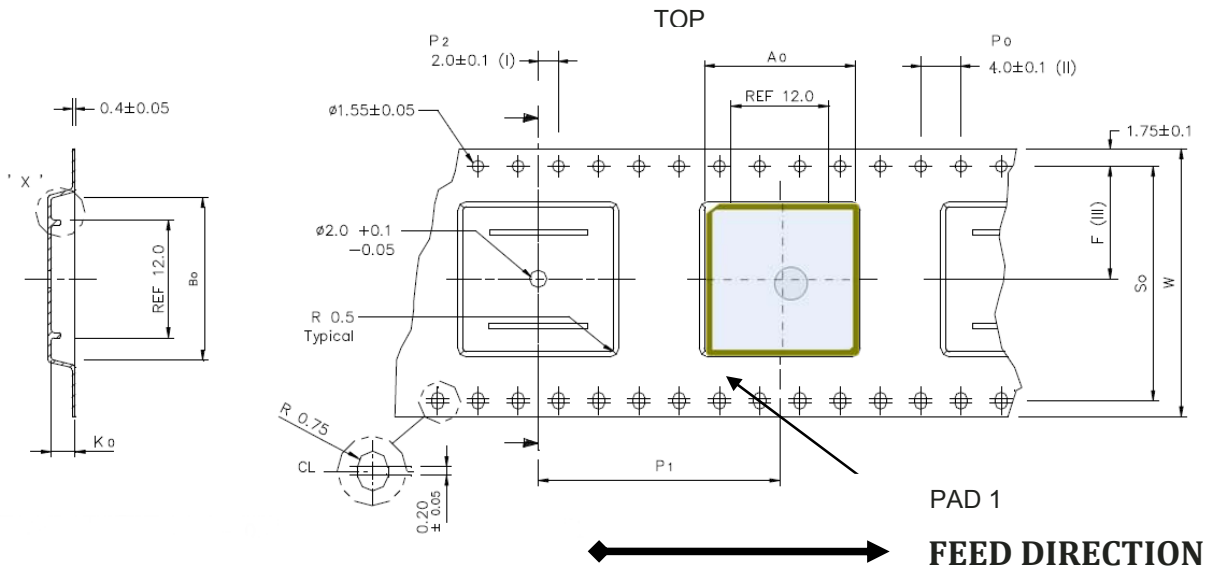

FIGURE 9 – CARRIER

	ORG1218	ORG1208
A ₀	20.50 ± 0.1	18.00 ± 0.1
B ₀	20.50 ± 0.1	18.00 ± 0.1
K ₀	07.30 ± 0.1	03.60 ± 0.1
F	14.20 ± 0.1	14.20 ± 0.1
P ₁	24.00 ± 0.1	24.00 ± 0.1
S ₀	28.40 ± 0.1	28.40 ± 0.1
W	32.00 ± 0.3	32.00 ± 0.3

FIGURE 10 – CARRIER DIMENSIONS [mm]

Carrier material: Conductive Polystyrene

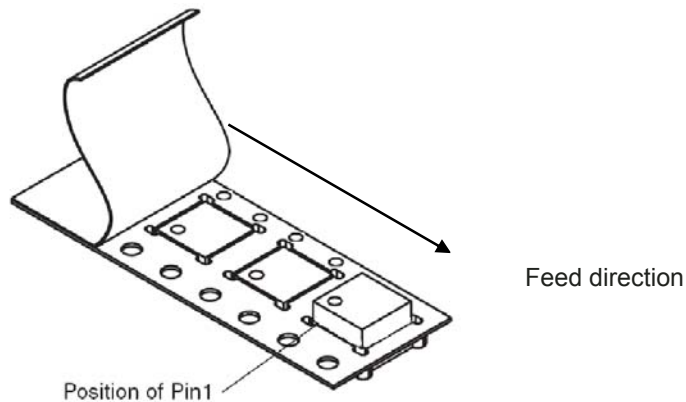

FIGURE 11 – MODULE POSITION

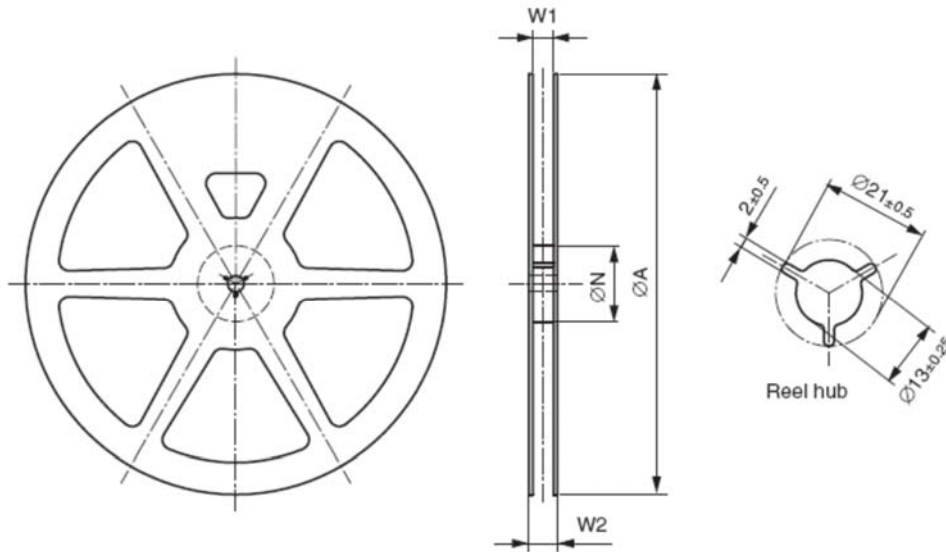

FIGURE 12 – REEL

ØA	330.00 ± 0.85
ØN	60.00 ± 0.5
W1	33.00 ± 0.5
W2	39.00 ± 0.5

TABLE 14 – REEL DIMENSIONS

Reel material: Antistatic Plastic

ORG1218: Each reel contains 175 modules.

ORG1208: Each reel contains 250 or 500 modules.

20.2. MOISTURE SENSITIVITY

The ORG12XX series module is MSL 3 designated device according to IPC/JEDEC J-STD-033B standard. Module in sample or bulk package should be baked prior to assembly at 125°C for 48 hours.

20.3. ASSEMBLY

The ORG12XX series module supports automatic assembly and reflow soldering processes. Recommended thickness of the solder paste stencil is 5mil, while openings in the pad mask are 100% to ensure sufficient solder volume.

Reflow soldering of the module is according to IPC/JEDEC J-STD-020D standard for LGA SMD.

Avoid reflow soldering process while module is facedown.

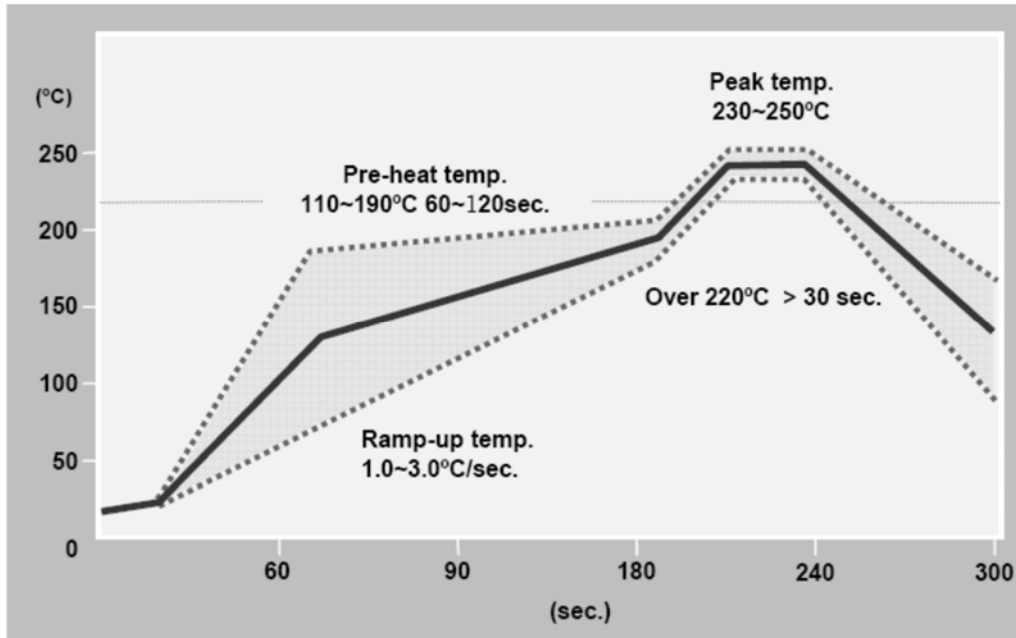

FIGURE 13 – RECOMMENDED SOLDERING PROFILE

Recommended peak reflow temperature is 250°C for 10 sec. for Pb-Free RoHS solder paste.
Absolute Maximum reflow temperature is 260°C for 10 sec.

20.4. REWORK

If localized heating is required to rework or repair the module, precautionary methods are required to avoid exposure to high temperatures that can result in permanent damage.

20.5. ESD SENSITIVITY

The module is ESD sensitive device and should be handled with care.



20.6. COMPLIANCES

The following standards are applied on the production of the ORG12XX series module:

- + IPC-6011/6012 Class2 for PCB manufacturing
- + IPC-A-600 Class2 for PCB inspection
- + IPC-A-610D Class2 for SMT acceptability

The ORG12XX series modules are manufactured in ISO 9001:2000 accredited facilities.

The ORG12XX series modules are manufactured in ISO 14001:2004 accredited facilities.

The ORG12XX series modules are designed, manufactured and handled to comply with and according to Pb-Free/RoHS Directive 2002/95/EC on the restriction of the use of certain hazardous substances in electrical and electronic equipment.

The ORG12XX series modules are manufactured in facilities under EU REACH regulation.

The ORG12XX series modules comply with the following EMC standards:

- + EU CE EN55022:06+A1(07), Class B
- + US FCC 47CFR Part 15:09, Subpart B, Class B
- + JAPAN VCCI V-3/2006.04





20.7. SAFETY INFORMATION

Improper handling and use can cause permanent damage to the device.

There is also the possible risk of personal injury from mechanical trauma or shocking hazard.

20.8. DISPOSAL INFORMATION

The product should not be treated as household waste.



For more detailed information about recycling electronic components, please contact your local waste management authority.

21. MECHANICAL SPECIFICATIONS

- + The module has miniature packaging in LGA SMD footprint sized 17mm x 17mm.
- + The module is built on miniature PCB enclosed with metallic shield box.
- + The module has 22 SMT pads with copper base/ENIG plating on the bottom side.
- + The package of the module has been optimized for automated pick and place assembly and reflow soldering processes.

21.1. ORG1218 MODULE

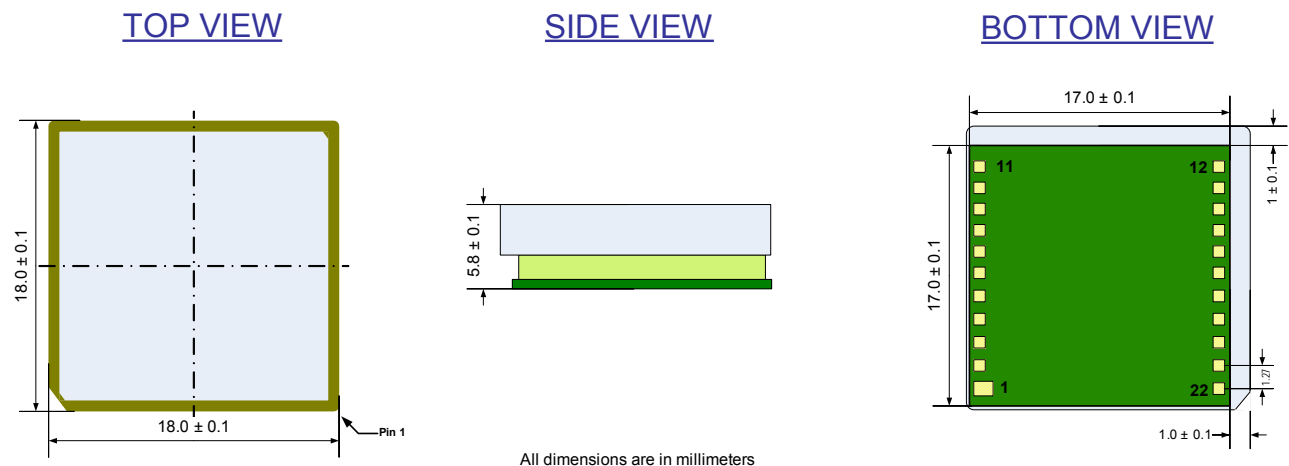

FIGURE 14 – ORG1218 MECHANICAL DRAWING

Dimensions	Length	Width	Height	Weight	
	mm	18.0 ± 0.1	18.0 ± 0.1	5.8 ± 0.1	gr
inch	0.709 ± 0.004	0.709 ± 0.004	0.228 ± 0.004	oz	0.18

TABLE 15 – ORG1218 MECHANICAL SUMMARY



21.2. ORG1208 MODULE

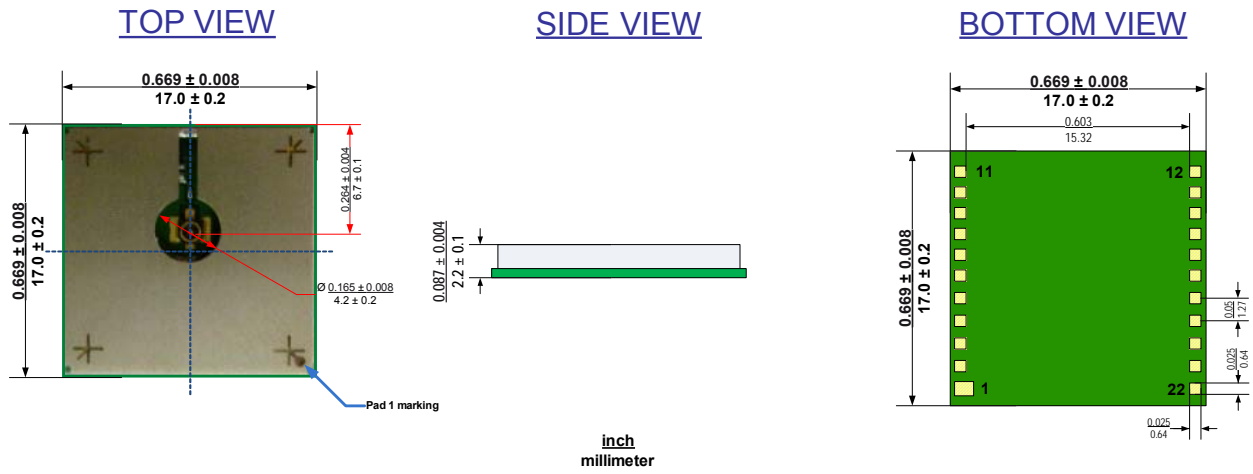

FIGURE 15 – ORG1208 MECHANICAL DRAWING

Dimensions	Length	Width	Height	Weight	
				gr	oz
mm	17.0 ± 0.2	17.0 ± 0.2	2.2 ± 0.1	1.4	
inch	0.669 ± 0.008	0.669 ± 0.008	0.088 ± 0.004	0.1	

TABLE 16 – ORG1208 MECHANICAL SUMMARY