

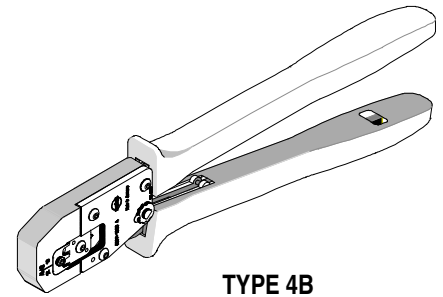

HAND CRIMP TOOL SPECIFICATION SHEET

Order No. 63811-1500



FEATURES

- % A full cycle ratcheting hand tool ensures complete crimps
- % Ergonomically designed soft handles
- % Precisely designed crimping profiles with simple contact positioning
- % Easy handling due to outstanding force ratio

SCOPE

Products: 10.00 mm (.394") Pitch Mini-Fit Sr.™ Crimp Terminals, 8 AWG.

Terminal Series No.	Terminal Order No.		Wire Size		Insulation Diameter		Strip Length		
	Loose Piece	* Reel	AWG	mm ²	mm	In.	mm	In.	
42815		42815-0030	42815-0031	8	8.50	5.00-6.75	.197-.266	9.00-10.00	.354-.394
		42815-0032	42815-0038						
42817		42817-0030	42817-0031	8	8.50	5.00-6.75	.197-.266	9.00-10.00	.354-.394
		42817-0032	42817-0038						
		42817-0130	42817-0131						
		42817-0132							

* Customer to cut off terminal from reel: 0.5mm (.020") maximum Cut-off Tab.
 • On Mini-Fit Sr.™ 8 AWG applications the insulation is stripped in both the conductor and insulation grips.

DEFINITION OF TERMS

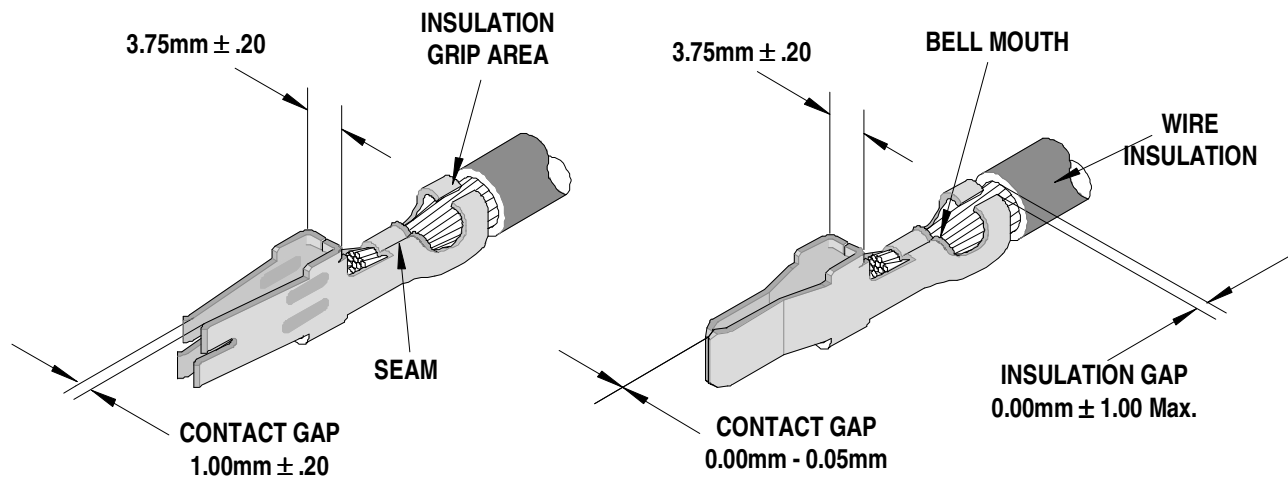

The above terminal drawing is a generic terminal representation. It is not an image of a terminal listed in the scope.

CONDITIONS:

After crimping, the crimp profiles should measure the following (see notes on page 3).

Terminal Series No.	Wire Size		Conductor Crimp				Insulation Crimp		Pull Force Minimum		Profile	
			Height (Ref)		Width (Ref)		Width (Ref)					
	AWG	mm ₂	mm	In.	mm	In.	mm	In.	N	Lb.	8	
42815	8	8.50	3.20-3.30	.126-.130	3.90	.154	N/A	N/A	400.0	90.00	X	
42817	8	8.50	3.20-3.30	.126-.130	3.90	.154	N/A	N/A	400.0	90.00	X	

OPERATION

Open the tool by squeezing the handles together, at the end of the closing stroke, the ratchet mechanism will release the handles, and the hand tool will spring open.

Crimping Terminals

1. Place the terminal into the correct die profile (8) until the terminal stopped by the locator.
2. Partially close the tool until the terminal is held in place.
3. Place a pre-stripped wire into the terminal and align the wire with the conductor and insulation grips visually. See Figure 1.
4. Close the tool until the ratchet releases.
5. Carefully remove the crimped terminal.

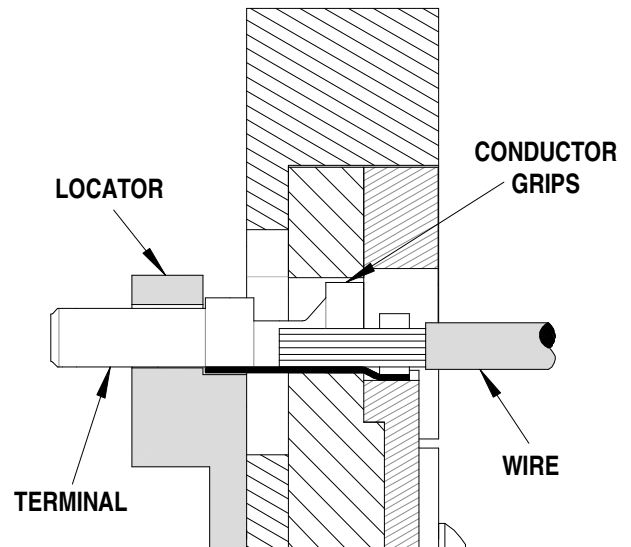

Figure 1

Note: The tamper proof ratchet action will not release the tool until it has been fully closed.

Maintenance

It is recommended that each operator of the tool be made aware of, and responsible for, the following maintenance steps:

1. Remove dust, moisture, and other contaminants with a clean brush, or soft, lint free cloth.
2. Do not use any abrasive materials that could damage the tool.
3. Make certain all pins; pivot points and bearing surfaces are protected with a thin coat of high quality machine oil. Do not oil excessively. The tool was engineered for durability but like any other equipment it needs cleaning and lubrication for a maximum service life of trouble free crimping. Light oil (such as 30 weight automotive oil) used at the oil points, every 5,000 crimps or 3 months, will significantly enhance the tool life.
4. Wipe excess oil from hand tool, particularly from crimping area. Oil transferred from the crimping area onto certain terminations may affect the electrical characteristics of an application.
5. When tool is not in use, keep the handles closed to prevent objects from becoming lodged in the crimping dies, and store the tool in a clean, dry area.

Miscrimps or Jams (See Figure 3)

Should this tool ever become stuck or jammed in a partially closed position, **Do Not force the handles open or closed**. The tool will open easily by rotating the slotted screw on the locator (back) side of the hand tool. See Figure 3.

Warranty

This tool is for electrical terminal crimping purposes only. This tool is made of the best quality materials. All vital components are long life tested. All tools are warranted to be free of manufacturing defects for a period of 30 days. Should such a defect occur, we will repair or exchange the tool free of charge. This repair or exchange will not be applicable to altered, misused, or damaged tools. This tool is designed for hand use only. Any clamping, fixturing, or use of handle extensions voids this warranty.

CAUTION: Molex crimp specifications are valid only when used with Molex terminals and tooling.

CAUTIONS:

1. Manually powered hand tools are intended for low volume or field repair. This tool is **NOT** intended for production use. Repetitive use of this tool should be avoided.
2. Insulated rubber handles are not protection against electrical shock.
3. Wear eye protection at all times.
4. Use only the Molex terminals specified for crimping with this tool.

Notes:

1. This tool should only be used for the terminals and wire gauges specified on this sheet.
2. This tool is not adjustable. Variations in tools, terminals, wire stranding, and insulation types may affect crimp height.
3. This tool is intended for standard conductor sizes. It may not give a good insulation crimp support for all insulation sizes.
4. Molex does not repair hand tools (see warranty above). The replacement parts listed are the only parts available for repair. If the handles or crimp tooling is damaged or worn, a new tool must be purchased.
5. Pull force should be used as the final criteria for an acceptable crimp. Pull force is measured with no influence from the insulation crimp. Refer to Molex Quality Crimping Handbook 63800-0029 for additional information on crimping and crimp testing.
6. Molex does not certify crimp hand tools.
7. Hand held crimping tools are intended for low volume, prototyping, or repair requirements only.

CAUTION: Repetitive use of this tool should be avoided.

PARTS LIST

Item Number	Order Number	Description	Quantity
1	63811-1575	Locator	1

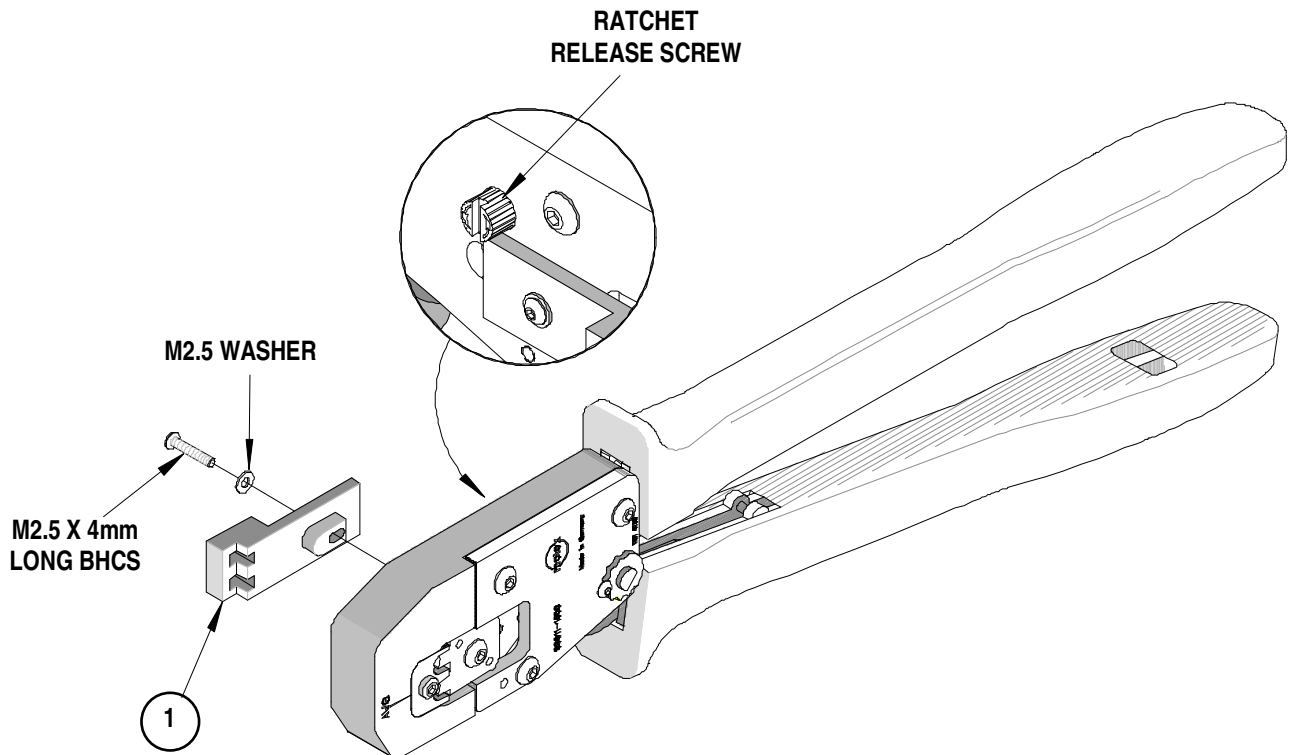

Figure 3

Americas Headquarters
 Lisle, Illinois 60532 U.S.A.
 1-800-78MOLEX
 amerinfo@molex.com

Far East North Headquarters
 Yamato, Kanagawa, Japan
 81-462-65-2324
 feninfo@molex.com

Far East South Headquarters
 Jurong, Singapore
 65-6-268-6868
 fesinfo@molex.com

European Headquarters
 Munich, Germany
 49-89-413092-0
 eurinfo@molex.com

Corporate Headquarters
 2222 Wellington Ct.
 Lisle, IL 60532 U.S.A.
 630-969-4550
 Fax: 630-969-1352

Visit our Web site at <http://www.molex.com>