

ISP3010

Built-in Antennas Smart Module

Ultra-Wide Band and Bluetooth Low Energy

This highly miniaturized LGA module, 14 x 14 x 1.5 mm, is based on the DW1000 UWB transceiver and nRF52832 BLE chip. Using a simple user interface via the SPI connection and integrating a Cortex™ M4 CPU, flash and RAM memory combined with optimized antennas, ISP3010 offers the perfect stand-alone ranging module solution for security bubble applications. For longer range applications, ISP3010 can be used in conjunction with an external UWB antenna.

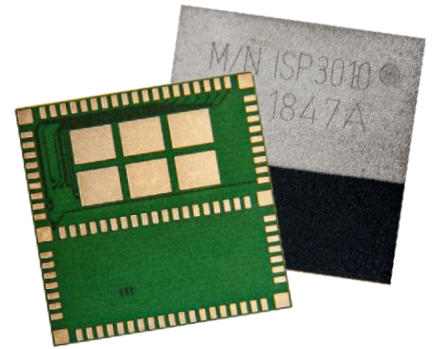

Key Features

- IEEE802.15.4-2011 UWB compliant
- Single Mode BLE 5 Ready
- NFC-A Tag for OOB pairing
- Spatial resolution better than 10 cm
- Fully integrated UWB & BLE matching and Antennas
- Integrated UWB 38.4 MHz and BLE 32 MHz & 32.768 kHz Clocks
- DC/DC converters
- UWB section based on DecaWave DW1000
- BLE section based on Nordic Semi nRF52
- UWB application controlled by the embedded 32-bit ARM Cortex M4F CPU
- 512 kB Flash and 64 kB SRAM
- Analog and Digital peripherals
- SPI interface
- Supply Voltage 1.8 V to 6.0 V
- Very small size 14.0 x 14.0 x 1.5 mm
- Temperature -40 to +85 °C



Applications

- Precision Real Time Location Systems (RTLS) for Healthcare, Sport and Wellness, Consumer, Industrial ...
- Security bubble
- Access control
- Indoor positioning

Pending Certifications

- Fully FCC certified module
- Fully CE certified module
- Fully IC certified module
- Bluetooth SIG certified QDL listing
- RoHS compliant

Contents

1. Block Diagram	3
2. Specifications	4
2.1. General Notice	4
2.2. Absolute Maximum Ratings.....	4
2.3. Operating Conditions	4
2.4. Current Consumption	5
2.5. Clock Sources.....	5
2.6. Radio Specifications.....	6
2.7. Electrical Schematic.....	8
3. Pin Description	9
4. Mechanical Outlines.....	11
4.1. Mechanical Dimensions	11
4.2. SMT Assembly Guidelines	13
4.3. Antenna Keep-Out Zone	13
5. Product Development Tools	14
5.1. Hardware	14
5.2. Firmware	14
5.3. Development Tools	15
6. Reference Design	16
6.1. Anchor Board Design	16
6.2. Tag Board Design	18
7. Packaging & Ordering information	19
7.1. Marking.....	19
7.2. Prototype Packaging.....	19
7.3. Jedec Trays	19
7.4. Tape and Reel	20
7.5. Ordering Information	20
8. Storage & Soldering information.....	21
8.1. Storage and Handling	21
8.2. Moisture Sensitivity	21
8.3. Soldering information	22
9. Quality & User information.....	23
9.1. Pending Certifications	23
9.2. USA – User information	23
9.3. Canada – User information	23
9.4. RF Exposure Information	24
9.5. Informations concernant l'exposition aux fréquences radio (RF)	24
9.6. Discontinuity	24
9.7. Disclaimer	25

1. Block Diagram

This module is based on DecaWave DW1000 single-chip UWB transceiver and nRF52832 Nordic Semiconductor 2.4GHz wireless System on Chip (SoC). It integrates a 32-bit ARM Cortex™ M4 CPU, 512 kB flash memory, 64 kB RAM as well as analog and digital peripherals. Despite the small size of 14.0 x 14.0 x 1.5 mm, the module integrates decoupling capacitors, 38.4 MHz crystal for UWB, 32 MHz and 32.768 kHz crystals for BLE, DC-DC converters, DC pulse power adapter for UWB, RF matching circuits and two antennas in addition to the wireless SoCs. Low power consumption and advanced power management enables battery lifetimes up to several months on a coin cell battery.

UWB communication is compliant to IEEE802.15.4. Using a simple user interface controlled over the air by Bluetooth, ISP3010 offers the perfect stand-alone ranging module solution for security bubble applications and up to 50 meters ranging applications. For longer range applications with typically few hundred meters distance, ISP3010 can be used in conjunction with an external UWB antenna.

BLE connectivity compliant with Bluetooth 5 Ready. ISP3010 BLE section can be used either in Peripheral or Central roles for BLE. Fully qualified BLE stacks for nRF52832 are implemented in the S132 SoftDevice which can be downloaded at no cost.

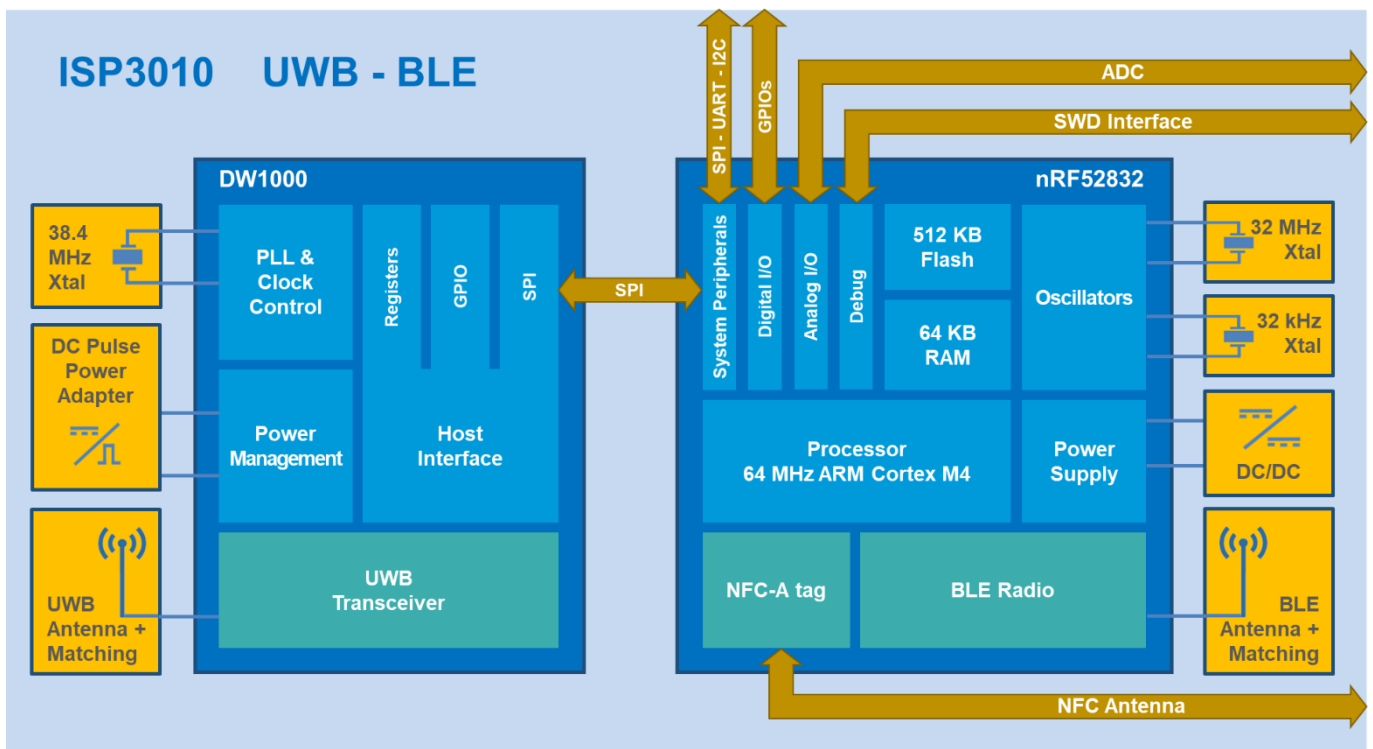

2. Specifications

2.1. General Notice

The electrical specifications of the module are directly related to the Nordic Semiconductor specifications for nRF52 chipset series and the Decawave specifications for DW1000 chipset. Bellow information is only a summary of the main parameters. For more detailed information, especially about current consumption, please refer to the up-to-date specification of the chipset available on Nordic Semi and Decawave websites.

2.2. Absolute Maximum Ratings

Parameter	Min	Typ	Max	Unit
Supply Voltage VIN	-0.3		3.9	V
Supply Voltage VDDIO	-0.3		4.0	V
IO Pins P0.xx, GPIOx, SPICLK, SPIMISO, SPIMOSI, SPICS, SRESET, WAKEUP	-0.3		3.6	V
UWB RF Input Level			0	dBm
BLE RF Input Level			10	dBm
NFC Antenna pin current			80	mA
Storage Temperature	-40		+85	°C
Moisture Sensitivity Level			5	-
Flash Endurance			10000	cycles

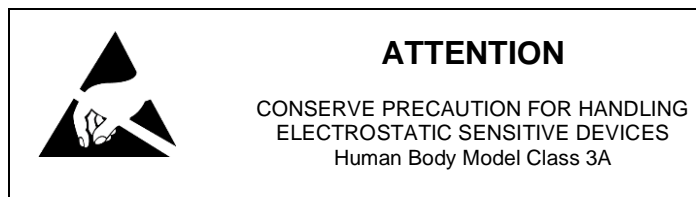

2.3. Operating Conditions

Parameter	Min	Typ	Max	Unit
Operating Supply Voltage VIN	1.8	3.0	6.0	V
Operating Supply Voltage VDDIO (used during programming of calibration settings in DW1000 OTP)	3.7	3.8	3.9	V
Operating Input Voltage IO Pins P0.xx	-0.3		3.3	V
Operating Input Voltage IO Pins GPIOx	-0.3		3.3	V
Operating Temperature Range	-30	+25	+85	°C

2.4. Current Consumption

Parameter	Min	Typ	Max	Unit
UWB receiver			180	mA
UWB transmitter			140	mA
UWB idle mode		18		mA
UWB sleep mode		1		µA
UWB deep sleep mode		100		nA
BLE Peak current, Receiver active ⁽¹⁾		6.1		mA
BLE Peak current, Transmitter active +4 dBm Output Power ⁽²⁾		7.9		mA
BLE Peak current, Transmitter active 0 dBm Output Power ⁽²⁾		5.4		mA
CPU System OFF current, no RAM retention		0.7		µA
CPU System ON base current, full RAM retention		1.5		µA
CPU Additional RAM retention current per 4 KB block		40		nA

(1) DC-DC enabled, Power supply 3V, 1 Msps

(2) DC-DC enabled, Power supply 3V

2.5. Clock Sources

Parameter	Min	Typ	Max	Unit
Internal High Frequency Clock for RF Stability: 38.4 MHz Crystal Frequency Tolerance ⁽¹⁾			± 30	ppm
Internal High Frequency Clock for RF Stability: 32 MHz Crystal Frequency Tolerance ⁽¹⁾			± 40	ppm
Internal Low Frequency Clock for BLE Synchronization: 32.768 kHz Crystal Frequency Tolerance ⁽¹⁾			± 40	ppm
Internal Low Frequency Clock for BLE Synchronization: RC Oscillator ⁽²⁾			± 250	ppm
RF Frequency tolerance: For UWB operation Channel 5			± 30	ppm
RF Frequency tolerance: For BLE operation Channels 0 to 39			± 40	ppm

(1) Including initial tolerance, drift, aging, and frequency pulling

(2) Frequency tolerance after calibration

2.6. Radio Specifications

Parameter	Min	Typ	Max	Unit
UWB channel 5 center frequency (1) (2)		6489.6		MHz
UWB channel 3 center frequency (2)		4492.8		MHz
UWB channel bandwidth		499.2		MHz
UWB Input at 1dB compression point		-39		dBm
UWB Rx sensitivity Level for BER <1% (3)		-93		dBm
UWB Output Power spectral density		-39	-35	dBm/MHz
UWB Antenna Gain channel 5 (1)		2.6		dBi
UWB Load impedance		50		Ω
UWB Range Open field @ 1 m height (1) (3)		50		m
UWB Range Open field @ 1 m height (2) (3)		100		m
BLE Frequency Range	2402		2480	MHz
BLE Channel 0 to 39 Spacing		2		MHz
BLE Output Power Channels 0 to 39	-20		+4	dBm
BLE Rx sensitivity Level for BER <0,1% ideal Tx	-96			dBm
BLE Antenna Gain		-0.8		dBi
BLE EIRP	-20.8		3.2	dBm
BLE Range Open field @1m height (4)		70		m

- (1) With internal UWB antenna / Channel 5 only
- (2) With external UWB antenna
- (3) 6.8 Mbps / Preamble 256
- (4) Data Rate 1000 / 2000 Kbps

Typical UWB Antenna Return Loss

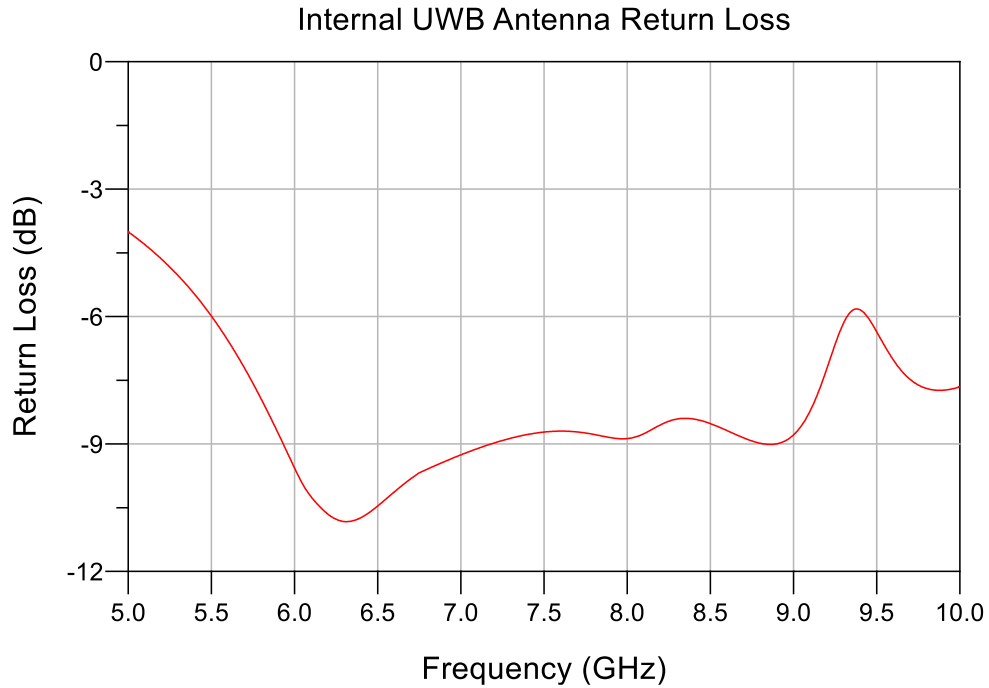

Radiation Patterns at 6.5 GHz

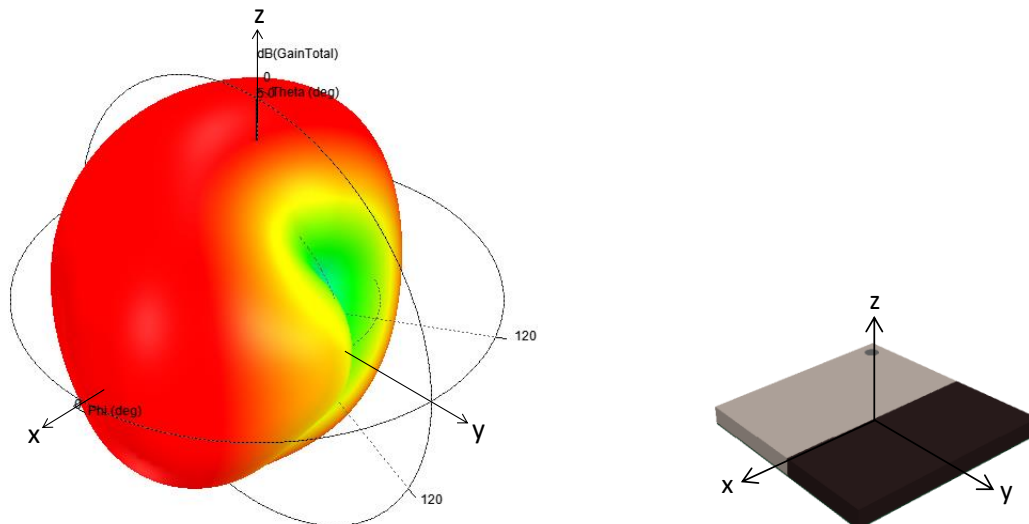

2.7. Electrical Schematic

Details of DW1000 connections

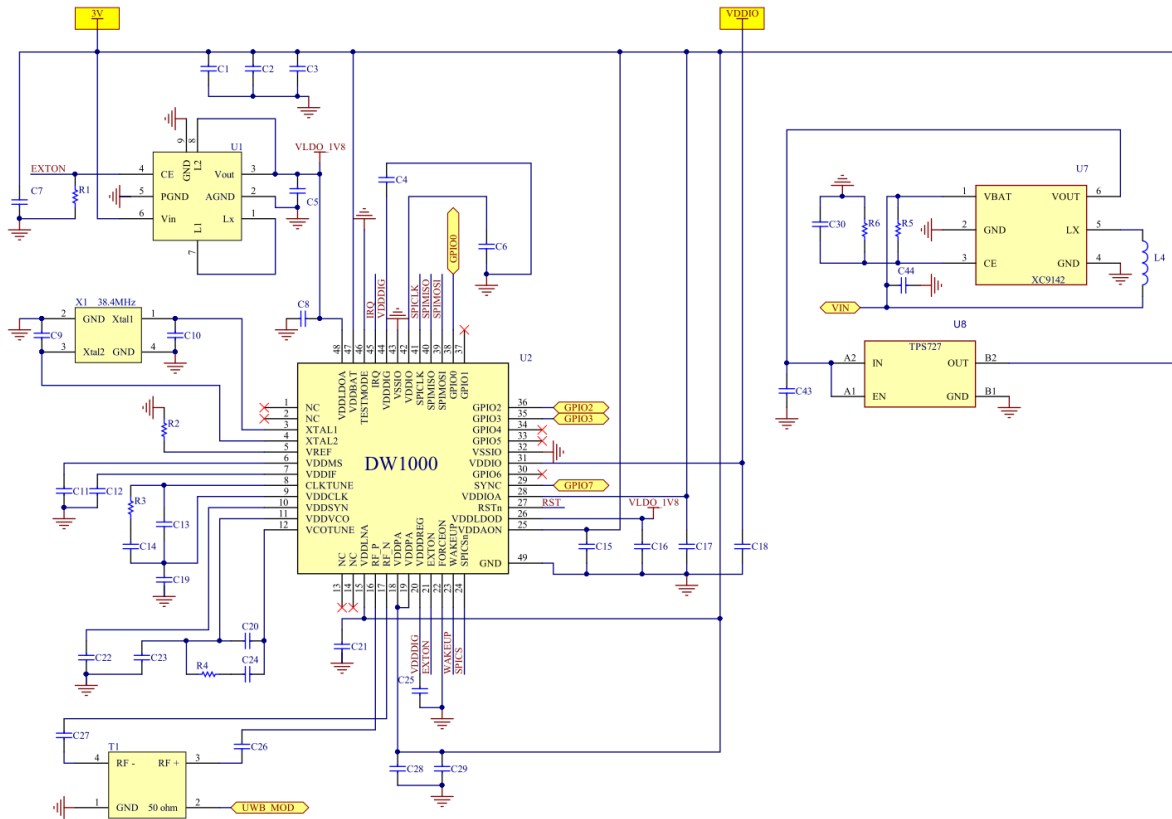

Details of nRF52832 connections

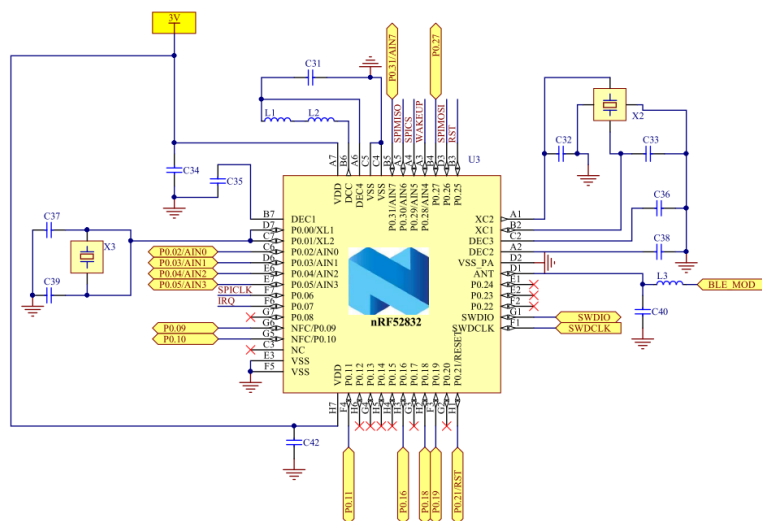

3. Pin Description

The module uses an LGA format on a 0.60 mm pitch. The pad layout follows the QFN Jedec standard for LGA parts. The NC pads are to be connected to isolated metal pads on the application PCB for mechanical stability and reliability (drop test).

Pin	Name	Pin function	Description
1 .. 4	GND	Ground	Ground – Must be connected to ground on application PCB
5	GPIO3 TXLED	Digital I/O	DW1000 general purpose I/O pin May be configured to drive a LED after transmission
6	GPIO2 RXLED	Digital I/O	DW1000 general purpose I/O pin May be configured to drive a LED during receive mode
7	GND	Ground	Ground – Must be connected to ground on application PCB
8	GPIO0 RXOKLED	Digital I/O	DW1000 general purpose I/O pin May be configured to drive a LED on reception of a good frame
9	GPIO7	Digital I/O	DW1000 general purpose I/O pin
10	NC	Not Connected	Isolated pad on application PCB for mechanical stability
11	VDDIO	Power	External supply for DW1000 OTP
12	3V	Output	3V output power generated by internal DC/DC converter and LDO
13	P0.11	Digital I/O	nRF52 general purpose I/O pin
14	P0.19	Digital I/O	nRF52 general purpose I/O pin
15	P0.05 AIN3	Digital I/O Analog Input	nRF52 general purpose I/O pin SAADC / COMP / LPCOMP input
16	P0.04 AIN2	Digital I/O Analog Input	nRF52 general purpose I/O pin SAADC / COMP / LPCOMP input
17	P0.03 AIN1	Digital I/O Analog Input	nRF52 general purpose I/O pin SAADC / COMP / LPCOMP input
18	P0.02 AIN0	Digital I/O Analog Input	nRF52 general purpose I/O pin SAADC / COMP / LPCOMP input
19	P0.27	Digital I/O	nRF52 general purpose I/O pin
20	P0.31 AIN7	Digital I/O Analog Input	nRF52 general purpose I/O pin SAADC / COMP / LPCOMP input
21 .. 29	GND	Ground	Ground – Must be connected to ground on application PCB
30	VIN	Power	External supply for ISP3010
31 .. 37	GND	Ground	Ground – Must be connected to ground on application PCB
38	UWB_ANT	RF I/O	Internal UWB antenna RF I/O pin Should be connected to Pin 39 UWB_MOD for normal operation
39	UWB_MOD	RF I/O	UWB RF I/O pin of the module Should be connected to Pin 38 UWB_ANT for normal operation
40 .. 47	GND	Ground	Ground – Must be connected to ground on application PCB
48	BLE_ANT	RF I/O	Internal BLE antenna RF I/O pin Should be connected to Pin 49 BLE_MOD for normal operation
49	BLE_MOD	RF I/O	BLE RF I/O pin of the module Should be connected to Pin 48 BLE_ANT for normal operation

Pin	Name	Pin function	Description
50 .. 51	GND	Ground	Ground – Must be connected to ground on application PCB
52	SWDIO	Digital I/O	nRF52 Serial Wire Debug I/O for debug and programming
53	SWDCLK	Digital Input	nRF52 Serial Wire Debug clock input for debug and programming
54	P0.21 RESET	Digital I/O	nRF52 general purpose I/O pin May be configured as nRF52 RESET pin
55	NC	Not Connected	Isolated pad on application PCB for mechanical stability
56	P0.18 TRACEDATA0	Digital I/O	nRF52 general purpose I/O pin Trace port output
57	P0.16 TRACEDATA1	Digital I/O	nRF52 general purpose I/O pin Trace port output
58	P0.12	Digital I/O	nRF52 general purpose I/O pin
59	P0.09 NFC1	Digital I/O NFC Input	nRF52 general purpose I/O pin NFC antenna connection pin
60	P0.10 NFC2	Digital I/O RF I/O	nRF52 general purpose I/O pin NFC antenna connection pin
61 .. 95	NC	Not Connected	Isolated pad on application PCB for mechanical stability
96 .. 101	GND	Ground	Ground – Must be connected to ground on application PCB

✚ ISP3010 pad placement and pin assignment for the LGA QFN package

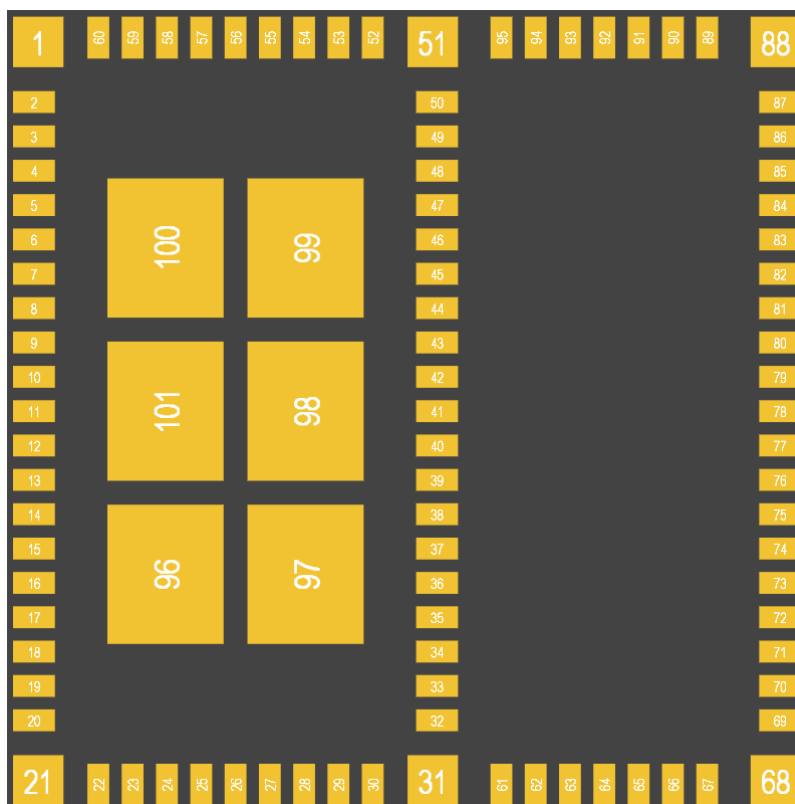

TOP VIEW

4. Mechanical Outlines

4.1. Mechanical Dimensions

Dimensional drawing for 14.00 x 14.00 x 1.56 mm, 101-Pad LGA Package

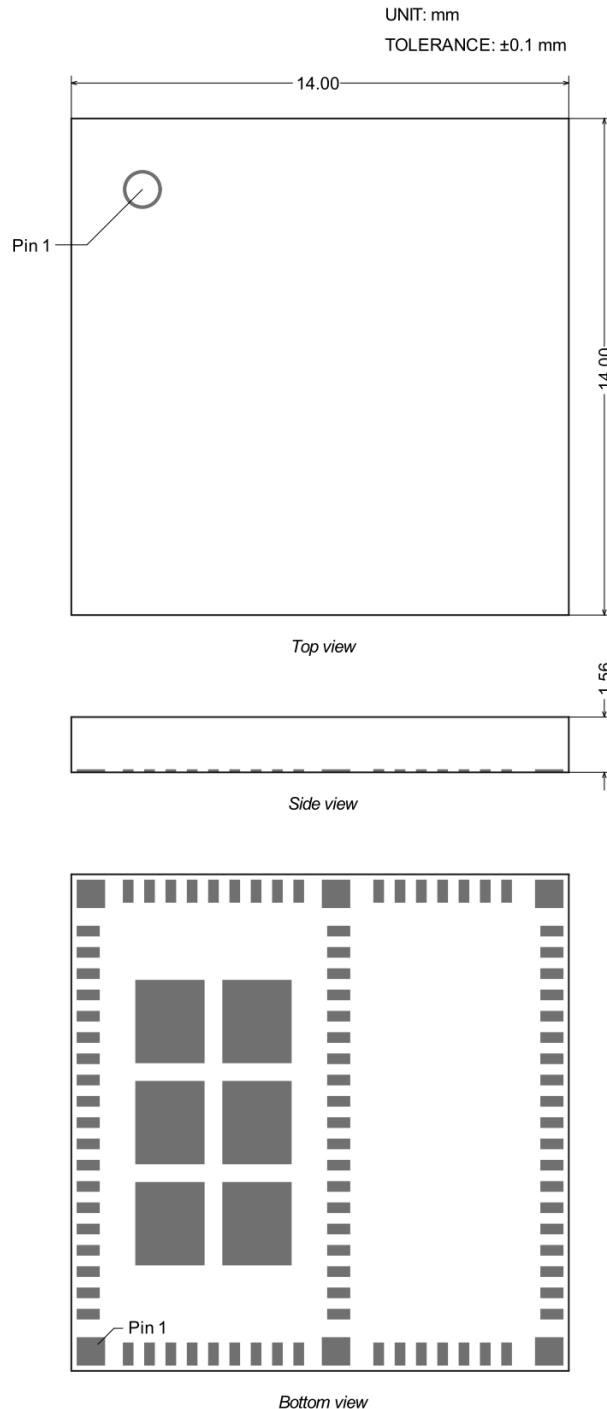

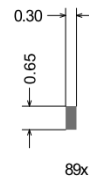
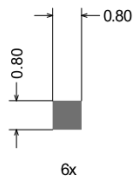
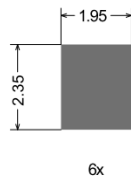
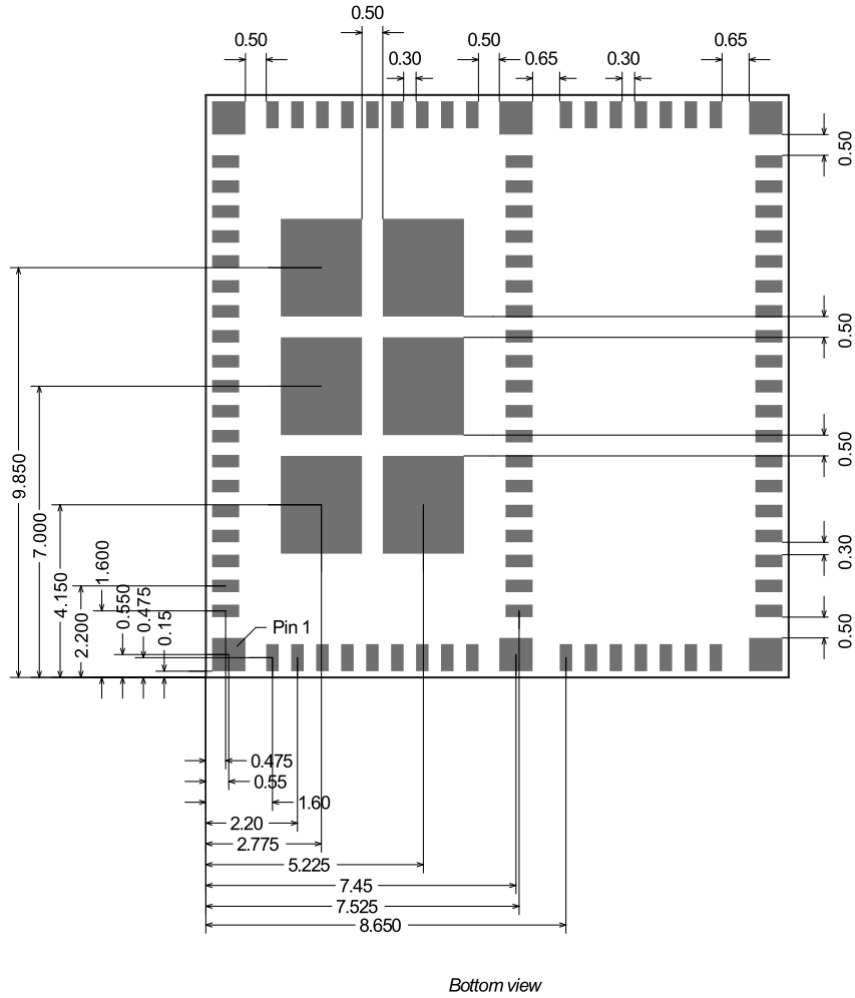

4.2. SMT Assembly Guidelines

For PCB Land Patterns and Solder Mask layout, Insight SiP recommends the use of the same dimensions as the module pads, i.e. 0.65 x 0.30 mm for standard pads, 0.80 x 0.80 mm for corner pads, 2.35 x 1.95 mm for mechanical pads.

Please contact Insight SiP for more detailed information.

4.3. Antenna Keep-Out Zone

For optimal antenna performance, it is recommended to respect a metal exclusion zone to the edge of the board: no metal, no traces and no components on any application PCB layer except mechanical LGA pads.

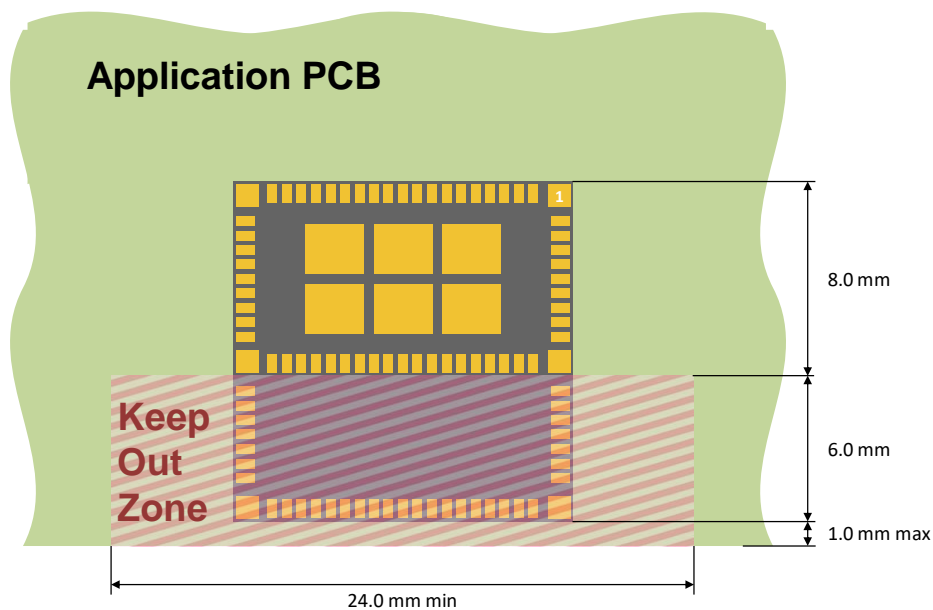

5. Product Development Tools

5.1. Hardware

In order to assist clients in developing their solutions based on the ISP3010, Insight SiP offers a Development Kit containing:

- 1x Interface Board with integrated J-Link OB JTAG/SWD Emulator
- 1x Test Board
- A ranging demonstration including 1x anchor board, 1x tag board, the embedded firmware and Android App
- Cables, Coin cell battery

Using this development kit, product developers can use a working solution as a starting point to develop their own products. Time to market is reduced by avoiding starting from a blank sheet of paper.

Please refer to the documentation for more information:

https://www.insightsip.com/fichiers_insightsip/pdf/ble/ISP3010/isp_lora_DS3010_DK.pdf

5.2. Firmware

ISP3010 supports Bluetooth Low Energy protocol stacks, ANT protocol stacks as well as 2.4 GHz protocol stacks, including Gazell. For more details regarding SoftDevice stacks and their compatibility with ISP3010 module version, please refer to the Nordic info center at <https://infocenter.nordicsemi.com>. All stacks can be downloaded at www.nordicsemi.com.

- ✚ The S132 SoftDevice is a Bluetooth low energy Central and Peripheral protocol stack solution. It supports up to twenty connections with an additional observer and a broadcaster role all running concurrently. The S132 SoftDevice integrates a Bluetooth low energy Controller and Host and provides a full and flexible API for building Bluetooth low energy.
- ✚ The S212 SoftDevice is an ANT protocol stack solution that provides a full and flexible Application Programming Interface (API) for building ANT System on ISP1507 solutions. The S212 SoftDevice simplifies combining the ANT protocol stack and an application on the same CPU.
- ✚ The S332 SoftDevice is a combined ANT™ and Bluetooth low energy (BLE) protocol stack solution. It supports all four Bluetooth low energy roles (Central, Peripheral, Observer, and Broadcaster) and ANT.

ISP3010 supports UWB protocol. Examples for data transmission or two-way ranging are available to download on the product page:

https://www.insightsip.com/fichiers_insightsip/pdf/ble/ISP3010/ISP3010_Source_Code.zip

5.3. Development Tools

The following development tools and software are recommended for using and testing ISP3010 module:

- ✚ Nordic Semiconductor nRFgo Studio or nRF Connect for Desktop:
Downloadable after registering at www.nordicsemi.com.
- ✚ Debugging and IDE:
SEGGER Embedded Studio (SES):
Downloadable from <https://www.segger.com/products/development-tools/embedded-studio/>

Keil MDK-ARM Lite (limited to 32 KB code)
Downloadable from <https://www.keil.com/demo/eval/arm.htm>.
- ✚ Segger J-Link Lite:
Downloadable from <http://www.segger.com/jlink-software.html>.
- ✚ nRF52 Software Development Kit (SDK):
nRF5-SDK can be downloaded at www.nordicsemi.com. It contains example of source codes applications (C language):
 - Precompiled HEX files
 - Source code
 - SES project files
 - Keil ARM project files
 - IAR project files
- ✚ UWB Software Development Kit (SDK):
SDK can be downloaded at <https://www.insightsip.com/products/combo-smart-modules/isp3010>. It contains example of source codes applications (C language):
 - Precompiled HEX files
 - Source code
 - SES project files
 - Ranging demo

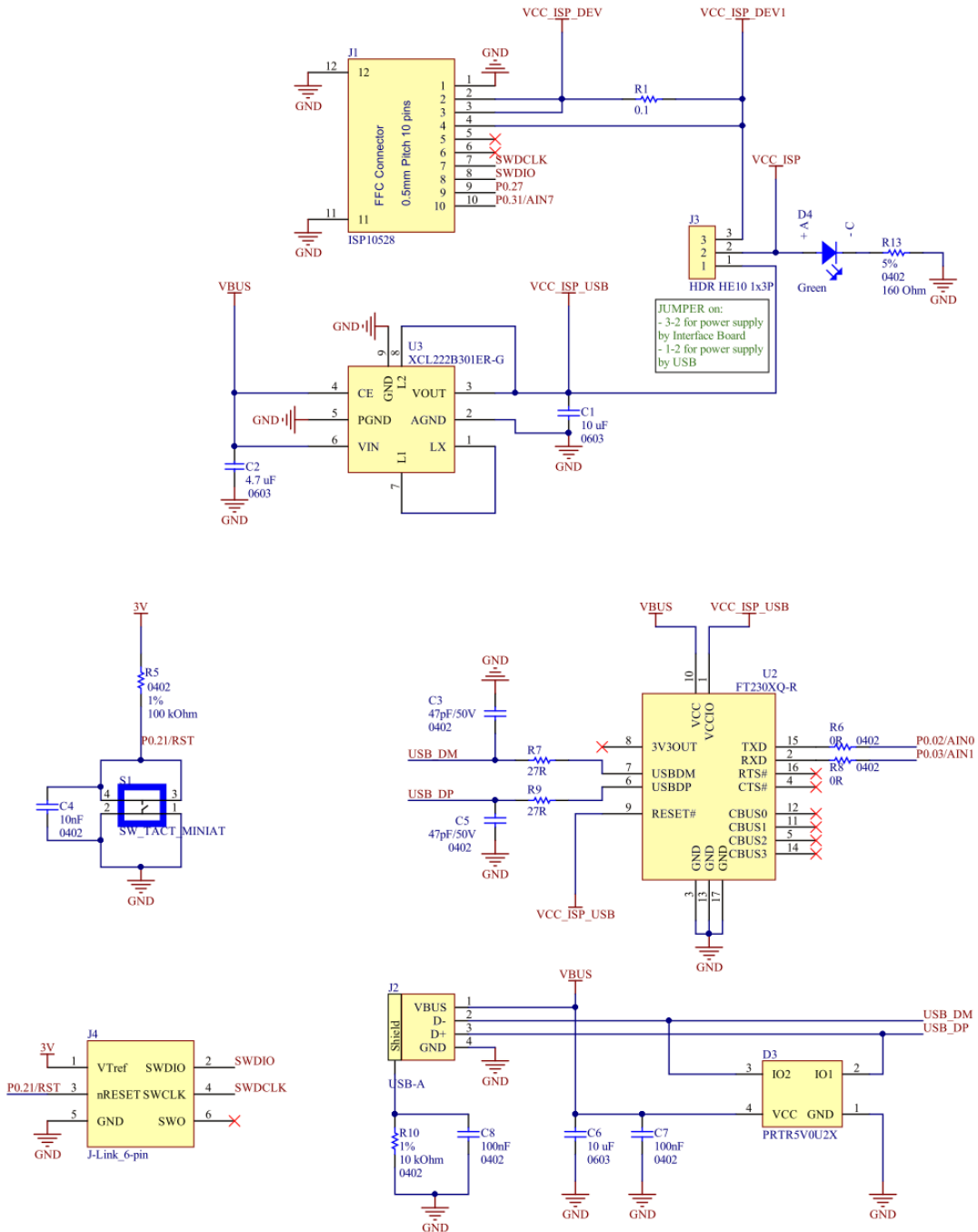

6.2. Tag Board Design

The complete TAG device makes use of Insight SiP ISP3010 BLE and UWB module together with passive components and a small primary coin-cell battery CR2032.

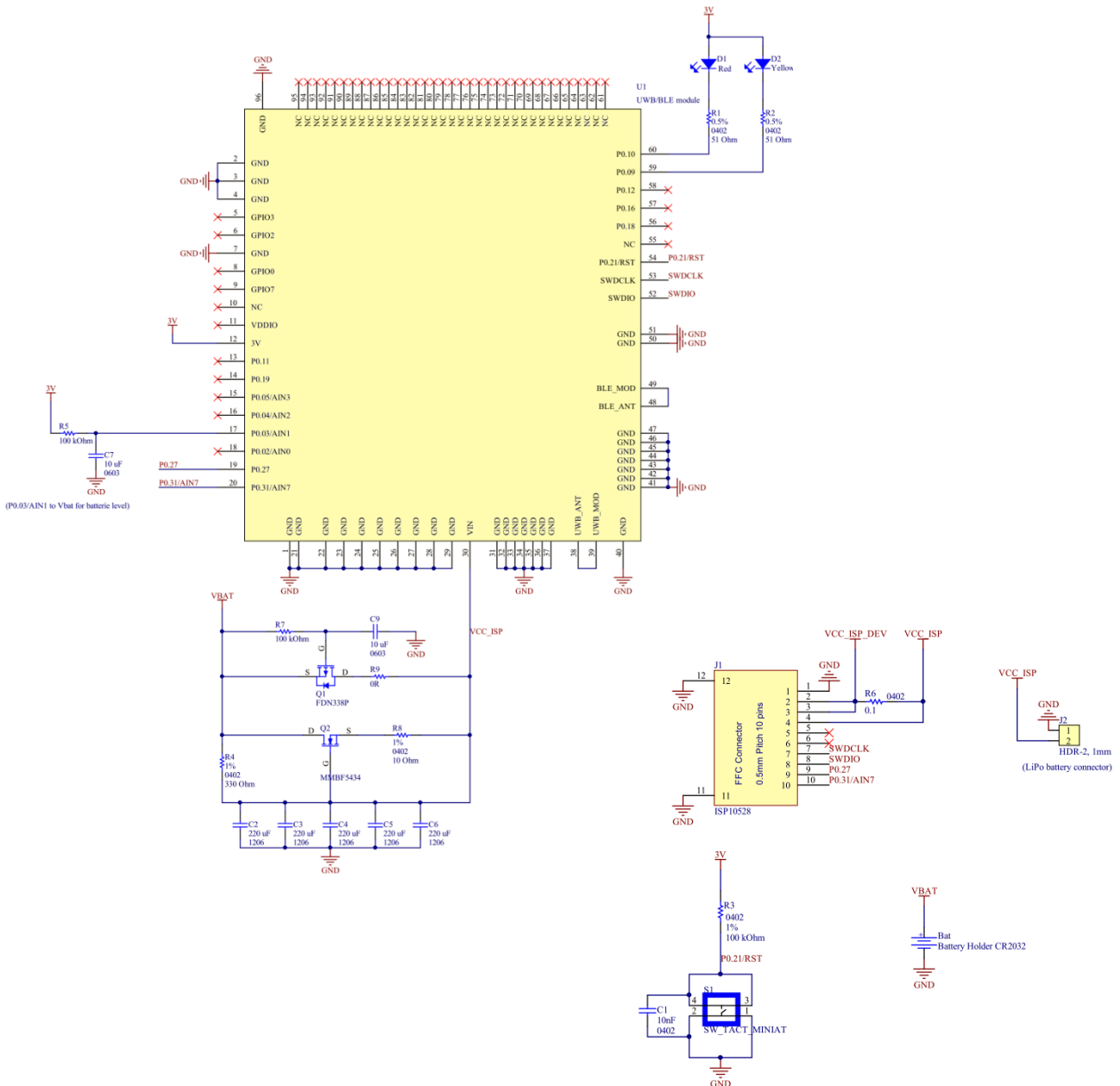

7. Packaging & Ordering information

7.1. Marking

M	/N	:	I	S	P	3	0	1	0
T	T		Y	Y	W	W	R		

ISP3010	Part Number
TT	2 letters Module Type (see section 7.5)
YY	2 digits year number
WW	2 digits week number
R	1 letter Hardware revision

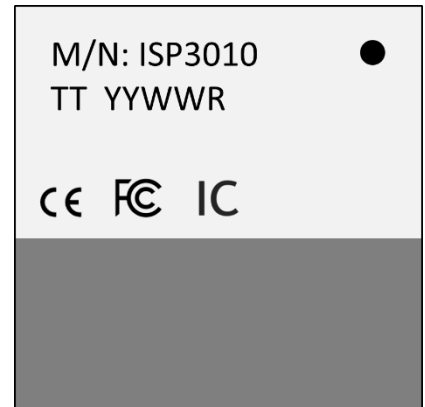

7.2. Prototype Packaging

For engineering samples and prototype quantities up to 99 units, deliveries are provided in thermoformed trays. Please order with "ST" code packaging suffix.

These parts must be baked prior to assembly (see section 8.2).

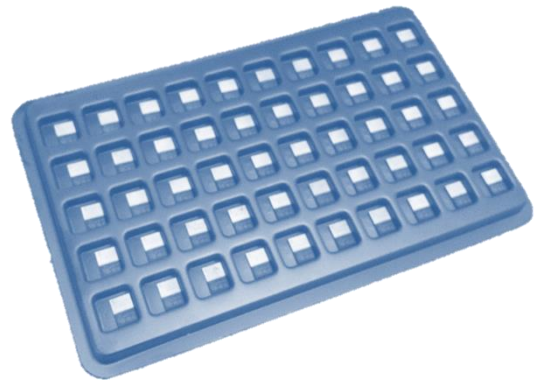

7.3. Jedec Trays

For higher quantities and volume production, ISP3010 are available in Jedec trays. They are delivered in sealed pack with desiccant pack and humidity sensors. These Jedec trays are also suitable for further baking. Please see section 8.2 for more information on moisture sensitivity.

Jedec trays are proposed in standard quantities of 100 units, 200 units and multiples of 200 units only. Please order with "J1" code packaging suffix for 100-unit tray and "J2" for 200 and multiple unit trays.

Complete information on Jedec trays is available on request.

7.4. Tape and Reel

ISP3010 are also available in Tape & Reel. They are delivered in sealed pack with desiccant pack and humidity sensors. Reels are proposed in standard quantities of 500 units (180mm / 7" reel) or 2000 units (330mm / 13" reel) only. Please order with "RS" code packaging suffix for 500-unit reels and "R2" for 2000-unit reels.

Complete information is available on request.

7.5. Ordering Information

I	S	P	3	0	1	0	-	T	T	-	Z	Z	
								▼	▼		▼	▼	
								▼	▼		▼	▼	
								▼	▼		▼	▼	
I	S	P	3	0	1	0							Part Number
													UWB & BLE with 512 kB Flash / 64 kB RAM
							-	U	X				Development kit ⁽¹⁾
										-	D	K	Test board ⁽¹⁾
										-	T	B	Anchor board ⁽¹⁾
										-	A	N	Tag board ⁽¹⁾
										-	T	G	Unsealed Tray Packaging
										-	S	T	Jedec Tray Packaging
										-	J	T	Reel of 500 units
										-	R	S	Reel of 2000 units
										-	R	2	

(1) Please see section 5.1 and refer to the following documentation for more information on development kit and test board:

http://www.insightsip.com/fichiers_insightsip/pdf/ble/isp_ble_DS3010_DK.pdf

8. Storage & Soldering information

8.1. Storage and Handling

- ✚ Keep this product away from other high frequency devices which may interfere with operation such as other transmitters and devices generating high frequencies.
- ✚ Do not expose the module to the following conditions:
 - Corrosive gasses such as Cl₂, H₂S, NH₃, SO₂, or NO_X
 - Extreme humidity or salty air
 - Prolonged exposure to direct Sunlight
 - Temperatures beyond those specified for storage
- ✚ Do not apply mechanical stress
- ✚ Do not drop or shock the module
- ✚ Avoid static electricity, ESD and high voltage as these may damage the module

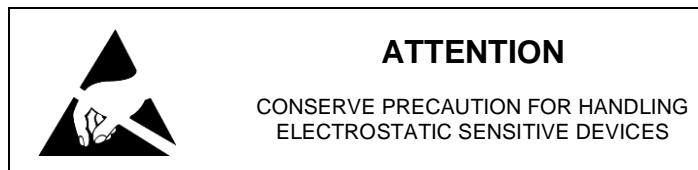

8.2. Moisture Sensitivity

All plastic packages absorb moisture. During typical solder reflow operations when SMDs are mounted onto a PCB, the entire PCB and device population are exposed to a rapid change in ambient temperature. Any absorbed moisture is quickly turned into superheated steam. This sudden change in vapor pressure can cause the package to swell. If the pressure exerted exceeds the flexural strength of the plastic mold compound, then it is possible to crack the package. Even if the package does not crack, interfacial delamination can occur.

Since the device package is sensitive to moisture absorption, it is recommended to bake the product before assembly. The baking process for dry packing is 24 hours at 125°C.

ISP3010 has been tested MSL-5 according to standards. After baking, modules can be exposed to ambient room conditions (approximately 30 °C/60%RH) during 48 hours before assembly on the PCB.



8.3. Soldering information

Recommendation for RoHS reflow process is according to Jedec J-STD-020 and 033 standard profiles.

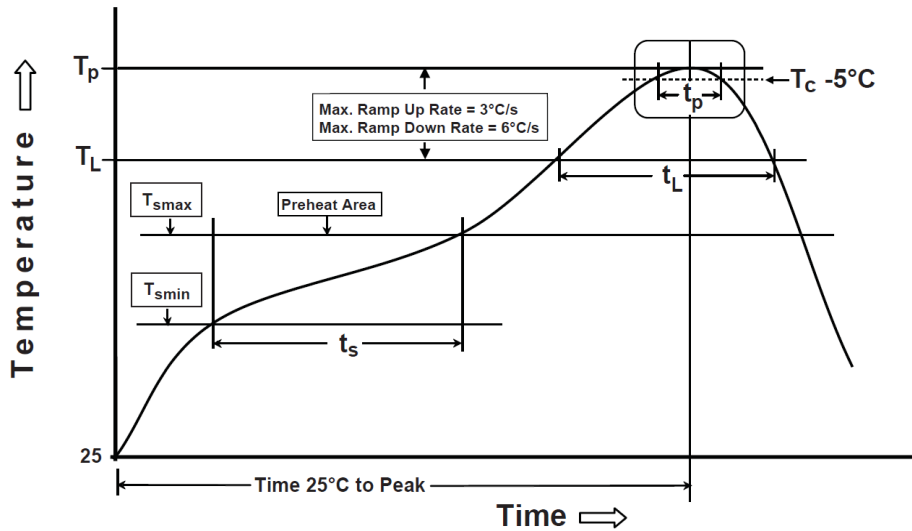

Preheat/Soak	
Temperature Min (T_{smin})	150 °C
Temperature Max (T_{smax})	200 °C
Time (t_s) from (T_{smin} to T_{smax})	60-120 sec
Ramp-up rate (T_L to T_p)	3 °C/sec max
Liquidous temperature (T_L)	217 °C
Time (t_L) maintained above T_L	60-150 sec

Peak package body temperature (T_p)	260°C (+0/-5°C)
Classification Temperature (T_c)	260 °C
Time (t_p) maintained above T_c-5 °C	30 sec
Ramp-down rate (T_p to T_L)	6 °C/sec max
Time 25 °C to peak temperature	8 mn max

9. Quality & User information

9.1. Pending Certifications

- ✚ FCC Identifier tbd
- ✚ CE: Complies with 1999/5/EC, EN300328 V1.9.1 – EC DoC N° tbd
- ✚ IC – Certification tbd
- ✚ Bluetooth SIG certified N° tbd
- ✚ RoHS compliant

9.2. USA – User information

This intends to inform how to specify the FCC ID of our module “ISP3010” on the product. Based on the Public Notice from FCC, the host device should have a label which indicates that it contains our module. The label should use wording such as:

“Contains FCC ID: 2AAQS-ISP3010”

Any similar wording that expresses the same meaning may be used.

The label of the host device should also include the below FCC Statement. When it is not possible, this information should be included in the User Manual of the host device:

*“This device complies with part 15 of the FCC rules. Operation is subject to the following two conditions.
(1) This device may not cause harmful interference
(2) This device must accept any interference received, including interference that may cause undesired operation.
Caution: Any Changes or modifications not expressly approved by the party responsible for compliance could void the user’s authority to operate the equipment.”*

9.3. Canada – User information

This intends to inform how to specify the IC ID of our module “ISP3010” on the product. According to Canadian standards “RSS-210” and “RSS-Gen”, the host device should have a label which indicates that it contains our module. The label should use wording such as:

“Contains IC: 11306A-ISP3010”

Any similar wording that expresses the same meaning may be used.

The label of the host device should also include the below IC Statement. When it is not possible, this information should be included in the User Manual of the host device:

“This device complies with Industry Canada licence-exempt RSS standard(s). Operation is subject to the following two conditions: (1) this device may not cause interference, and (2) this device must accept any interference, including interference that may cause undesired operation of the device.

Le présent appareil est conforme aux CNR d'Industrie Canada applicables aux appareils radio exempts de licence. L'exploitation est autorisée aux deux conditions suivantes : (1) l'appareil ne doit pas produire de brouillage, et (2) l'utilisateur de l'appareil doit accepter tout brouillage radioélectrique subi, même si le brouillage est susceptible d'en compromettre le fonctionnement.”

9.4. RF Exposure Information

This equipment complies with FCC/IC radiation exposure limits set forth for an uncontrolled environment and meets the FCC radio frequency (RF) Exposure Guidelines in Supplement C to OET65 and RSS-102 of the IC radio frequency (RF) Exposure rules. This equipment has very low levels of RF energy so that it is deemed to comply without maximum permissive exposure evaluation (MPE).

9.5. Informations concernant l'exposition aux fréquences radio (RF)

La puissance de sortie émise par l'appareil de sans fil est inférieure à la limite d'exposition aux fréquences radio d'Industry Canada (IC). Ce module a également été évalué et démontré conforme aux limites d'exposition aux RF d'IC dans des conditions d'exposition à des appareils mobiles et/ou portables.

9.6. Discontinuity

Normally a product will continue to be manufactured as long as all of the following are true:

- The manufacturing method is still available.
- There are no replacement products.
- There is demand for it in the market.

In case of obsolescence, Insight SiP will follow Jedec Standard JSD-48. A Product Discontinuation Notice (PDN) will be sent to all distributors and made available on our website. After this, the procedure goes as follows:

- Last Order Date will be 6 months after the PDN was published.
- Last Shipment Date will be 6 months after Last Order Date, i.e. 12 months after PDN.

9.7. Disclaimer

Insight SiP's products are designed and manufactured for general consumer applications, so testing and use of the product shall be conducted at customer's own risk and responsibility. Please conduct validation and verification and sufficient reliability evaluation of the products in actual condition of mounting and operating environment before commercial shipment of the equipment. Please also pay attention (i) to apply soldering method that don't deteriorate reliability, (ii) to minimize any mechanical vibration, shock, exposure to any static electricity, (iii) not to overstress the product during and after the soldering process.

The products are not designed for use in any application which requires especially high reliability where malfunction of these products can reasonably be expected to result in personal injury or damage to the third party's life, body or property, including and not limited to (i) aircraft equipment, (ii) aerospace equipment, (iii) undersea equipment, (iv) power plant control equipment, (v) medical equipment, (vi) transportation equipment, (vii) traffic signal equipment, (viii) disaster prevention / crime prevention equipment.

The only warranty that Insight SiP provides regarding the products is its conformance to specifications provided in datasheets. Insight SiP hereby disclaims all other warranties regarding the products, express or implied, including without limitation any warranty of fitness for a particular purpose, that they are defect-free, or against infringement of intellectual property rights. Insight SiP customers agree to indemnify and defend Insight SiP against all claims, damages, costs and expenses that may be incurred, including without any limitation, attorney fees and costs, due to the use of products.