



PRODUCT DATASHEET

Rose series

last update 13/12/2017

DETAILS

Product Number	FA15229_ROSE-MRK-S
Family	Rose
Type	Assembly
Color	white
Diameter	21,6 x 21,6 mm
Height	12,95 mm
Style	square
Optic Material	PC
Holder Material	
Fastening	tape, pin
Status	production ready
ROHS Compliant	Yes
Date Updated	13/12/2017



OPTICAL PROPERTIES

	Viewing	Light	Effi-		
LED	Angle	Beam	ciency	cd/lm	Connector
LUXEON M/MX	29 deg	Spot	86 %	2.170	-

H G F E D C B A

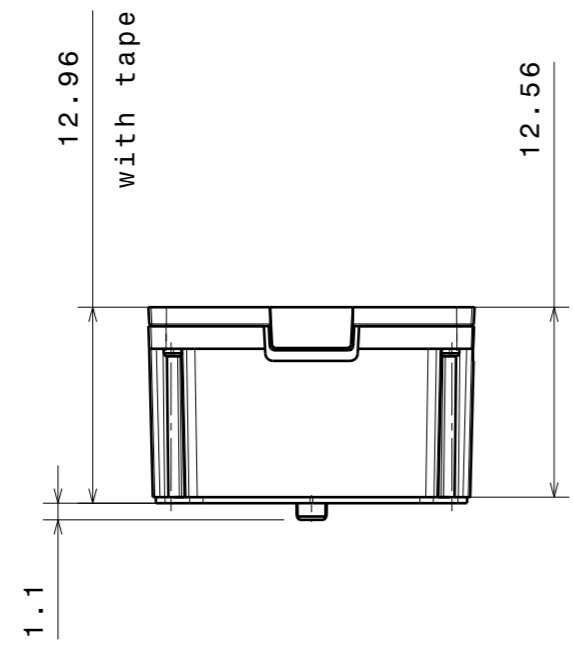

Front view

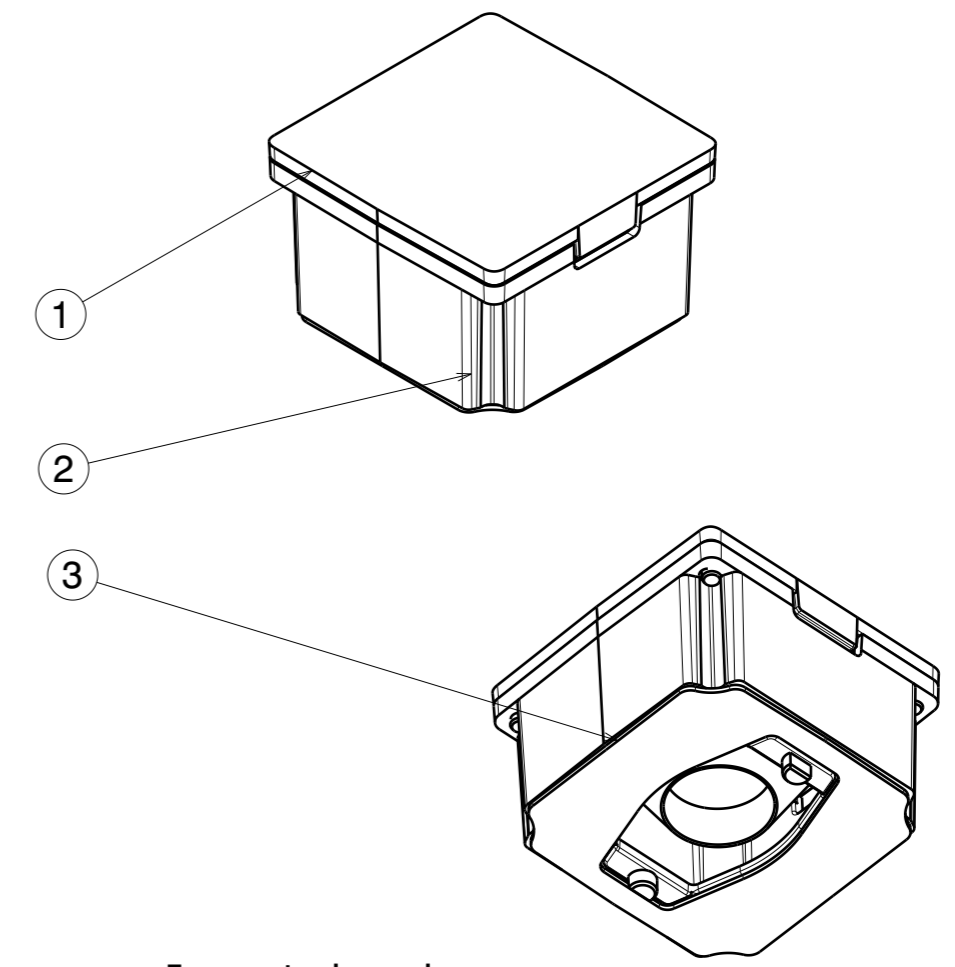

Isometric view

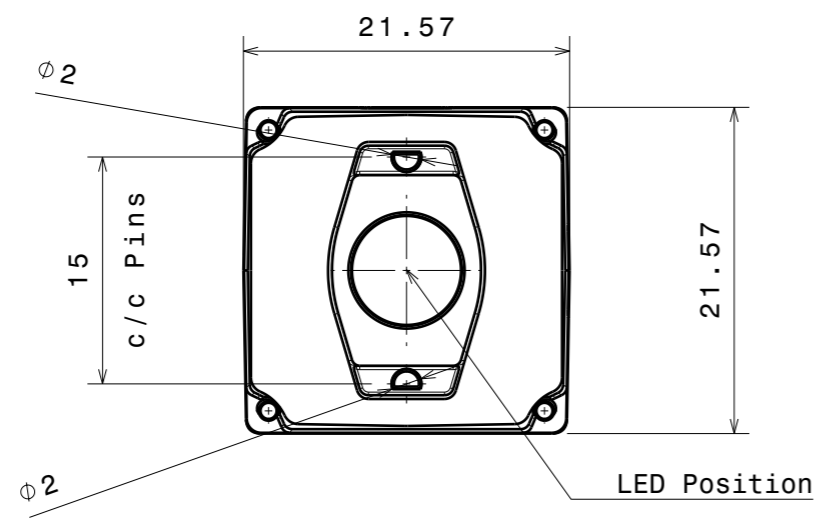

Bottom view

FA15229	ROSE-MRK-S
FA15232	ROSE-MRK-M
FA15233	ROSE-MRK-W

INDEX	PART NO	DESCRIPTION	MATERIAL	COLOUR
1	-	ROSE-MRK S/M/W	PC	clear
2	F14946	ROSE-Lt-HLD-MRK	PC	white
3	F14629	ROSE-TAPE	two-sided adhesive foam tape	

<p>Tolerances if not otherwise shown According to DIN ISO 2768-1 Linear measures: Up to 30mm class M, otherwise class C. According to DIN ISO 2768-2 Form and position: class L</p>			<p>Ledil Oy Salorankatu 10 FIN 24240 SALO Finland</p>		
	<p>THIRD ANGLE PROJECTION:</p>		<p>DRAWING TITLE ROSE-MRK MechanicalDrawing</p>		
<p>This drawing is the property of LEDiL Oy. It may not be reproduced, copied or communicated without a written agreement with LEDiL Oy.</p>		<p>SIZE A3</p>	<p>PART NUMBER FA15229/FA15232/FA15233</p>		
		<p>SCALE 2:1</p>	<p>WEIGHT -</p>	<p>SHEET 1/1</p>	

H G B A

Luminaire: LEDiL Oy F14951_ROSE-MRK-S_(Luxeon_M)_C3
Lamps: 1 x Luxeon_M_(LXR8-SW40)_382.455lm@250mA_P=2.77478W_I=0.250A

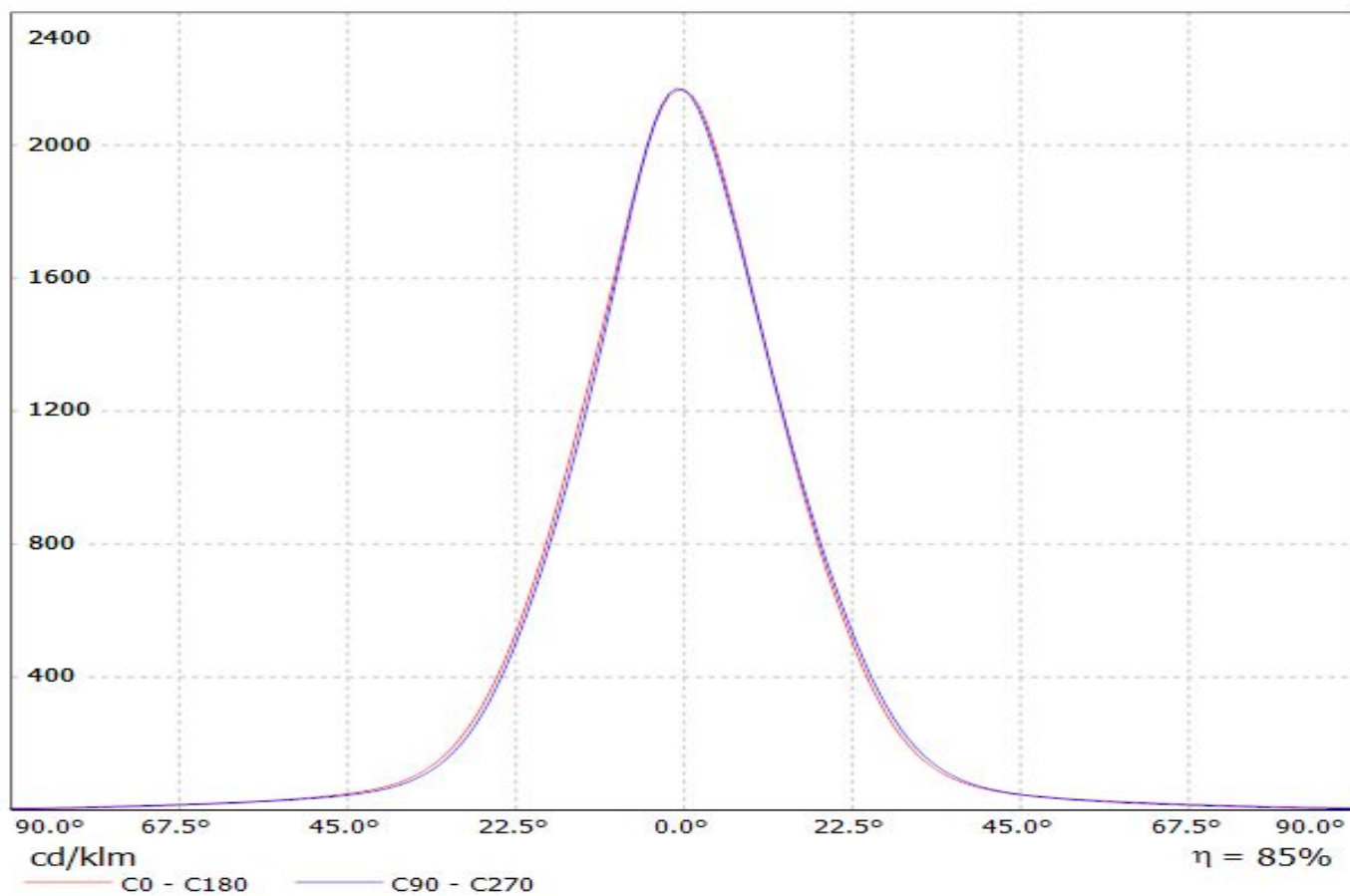

Luminaire: LEDiL Oy F14951_ROSE-MRK-S_(Luxeon_M)_C3
Lamps: 1 x Luxeon_M_(LXR8-SW40)_382.455lm@250mA_P=2.77478W_I=0.250A

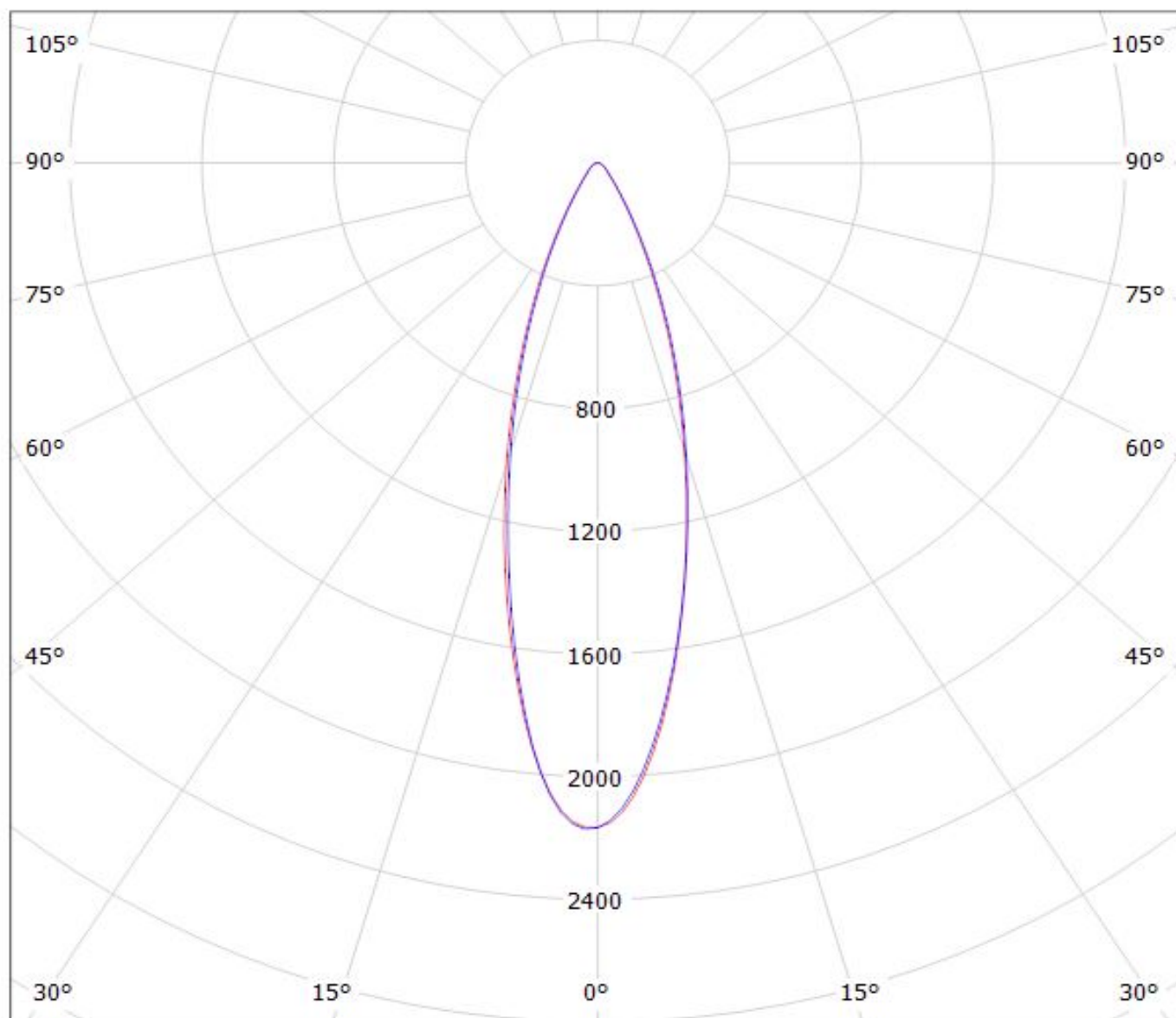

cd/klm

— C0 - C180 — C90 - C270

$\eta = 85\%$

NOTE: The typical divergence will be changed by different color, chip size and chip position tolerance. The typical total divergence is the full angle measured where the luminous intensity is half of the peak value.