

STRIP FORM
Bandware

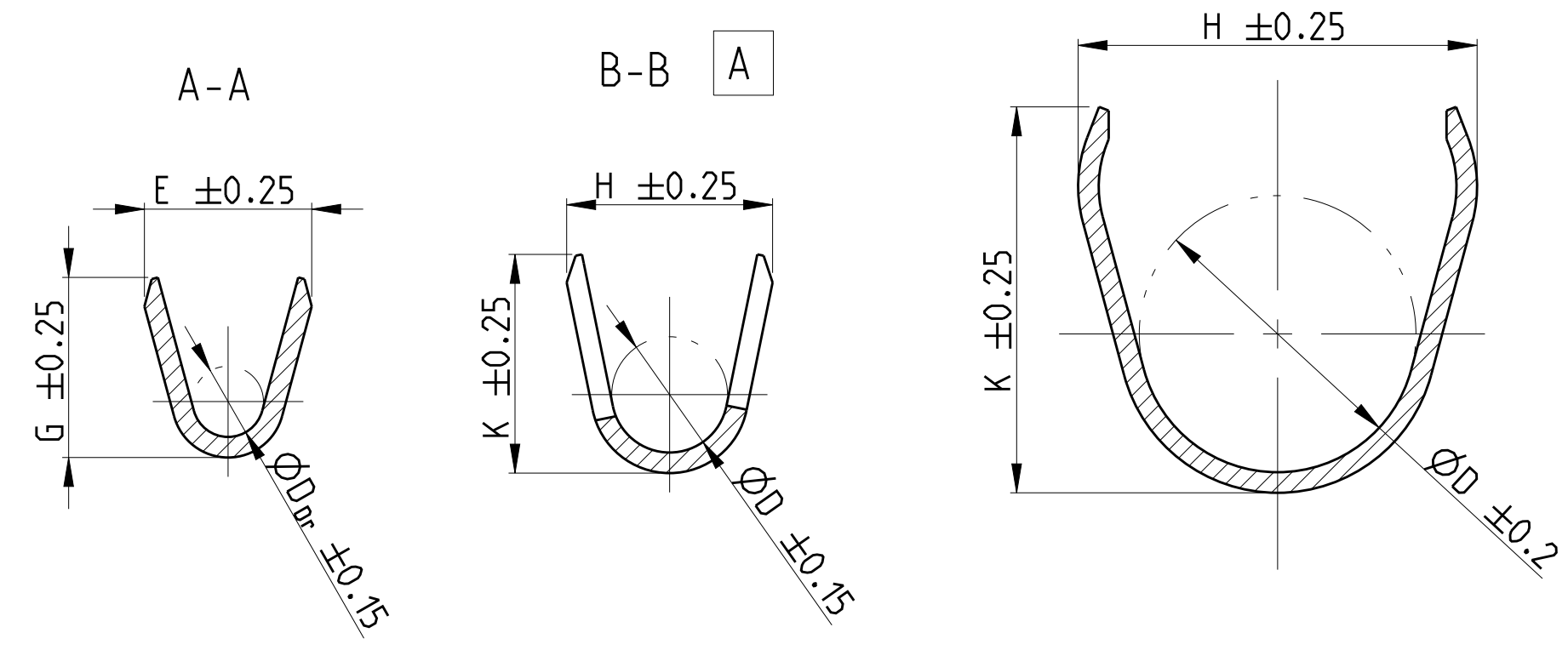

WIRE CRIMP
Drahtcrimp

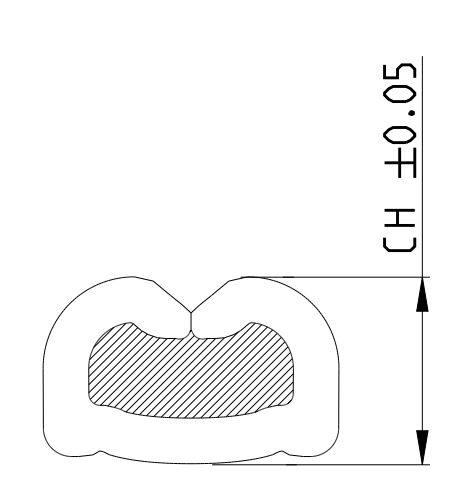

- 1 CONTACT AREA PRE SILVER MIN. 3µm
CANTILEVER SPRING PLAIN
Kontaktzone vorversilbert min. 3µm
Ueberfeder blank
- 2 CONTACT BODY NI-PLATING MIN. 0.5µm; CONTACT AREA PRE-GOLD MIN. 0.6µm
OVER NICKEL; CRIMP AREA PRE-TIN
CANTILEVER SPRING PLAIN
Kontaktkoerper vernickelt min. 0.5µm; Kontaktzone vorvergoldet min. 0.6µm ueber Nickel
Crimpzone vorverzinkt; Ueberfeder blank
- 3 IN THIS AREA CRACK SHAPING AT THE SURFACE PERMISSIBLE
In diesem Bereich Rissbildung in der Oberflaeche zulassig
- 4 PRE-TIN MIN. 1µm; CANTILEVER SPRING PLAIN
vorverzinkt min. 1µm; Ueberfeder blank

- AWG 12 TXL 828905-1 OR / oder 282536-1
AWG 12 GXL 638865-1
- ATTENTION! CONSTRUCTION OF THE CONTACT CAVITY IN THE AREA OF THE SINGLE WIRE SEAL IS $\phi 6.4^{+0.1}_{-0.05}$
Achtung! Die Kammer ist im Bereich der Einzeldichtung auf $\phi 6.4^{+0.1}_{-0.05}$ auszuliegen
- PUNCHED WITH VOLATILIZING STAMPING-OIL
Gestanzst mit verfluechtigendem Stanzoel

FLR-/FLK-WIRE
FLR-/FLK-Leitung

DESIGN 1
Ausfuehrung 1

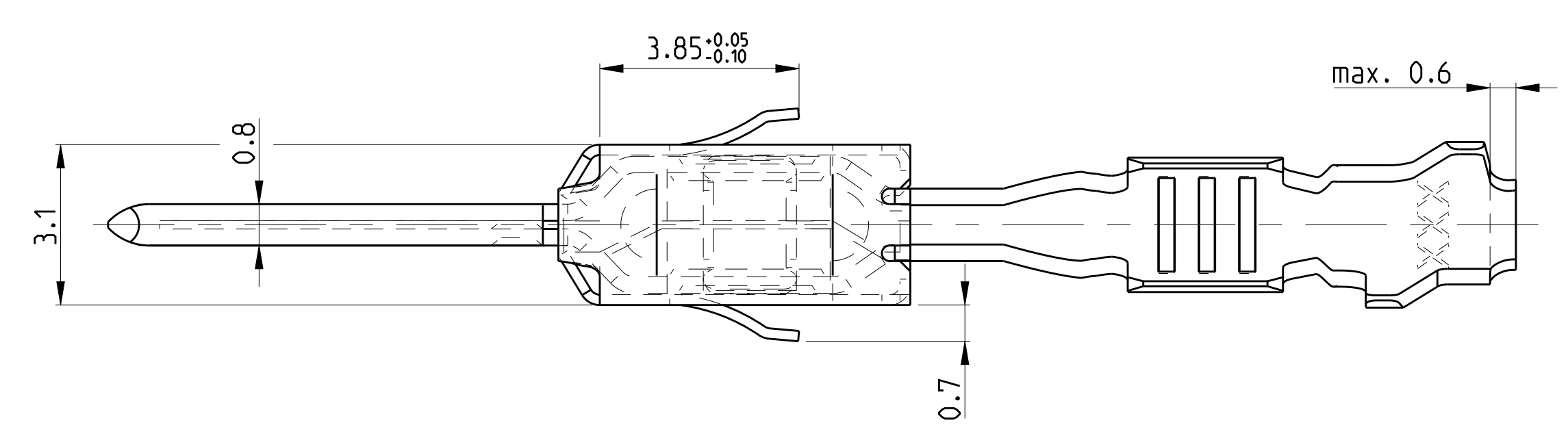
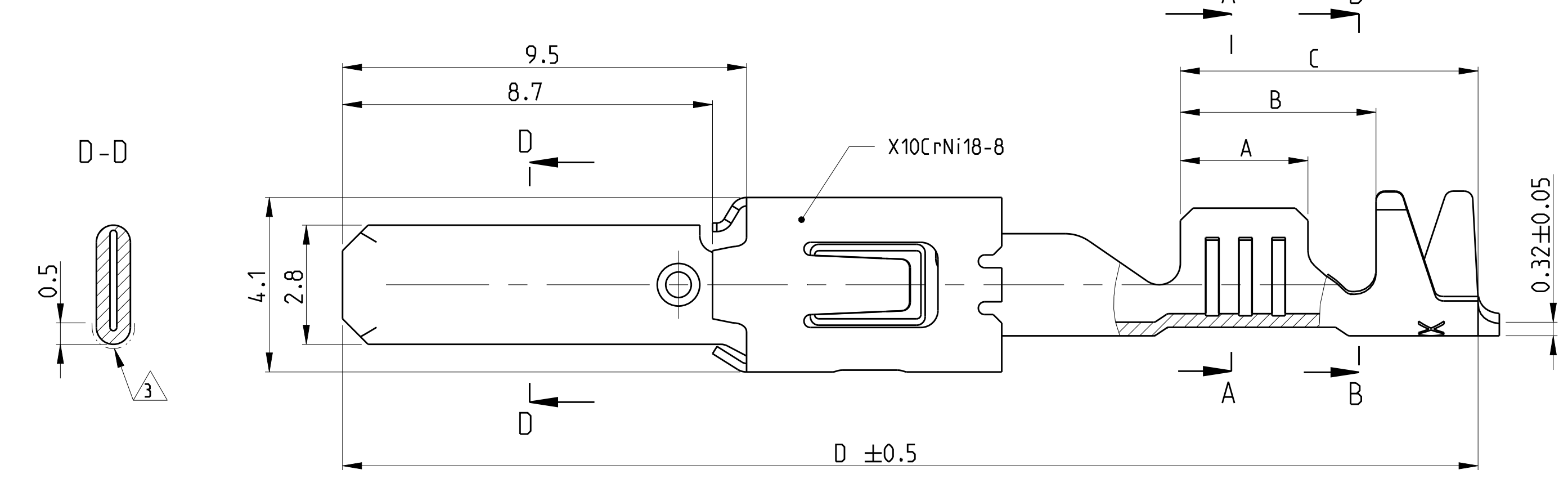

SINGLE WIRE SEAL
Einzeldichtungssystem

DESIGN 4
Ausfuehrung 4

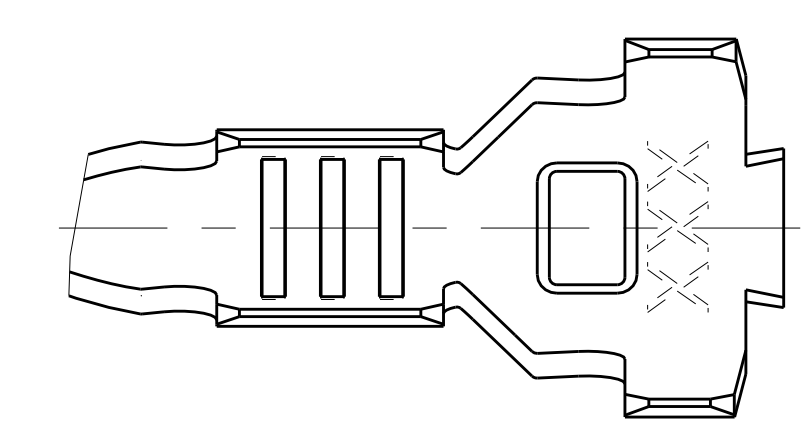
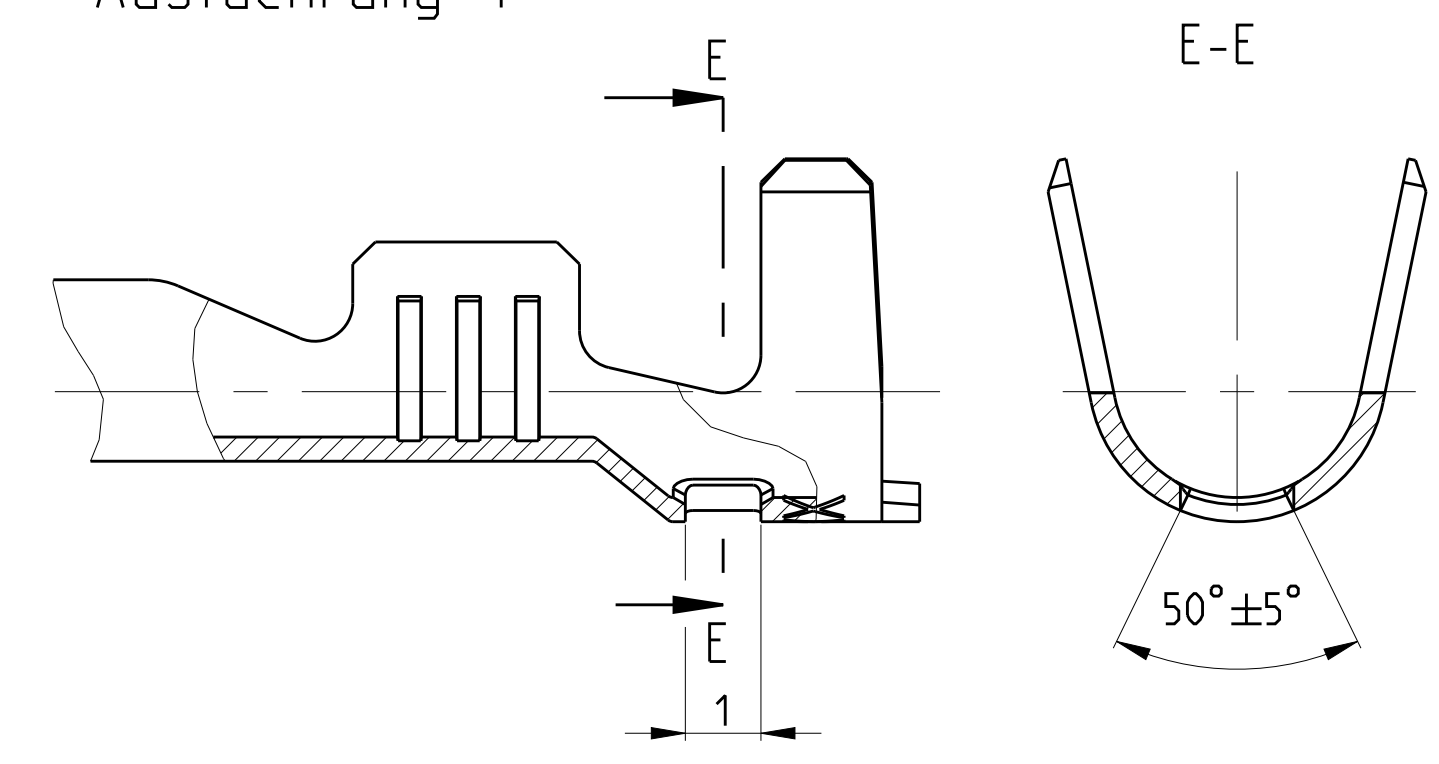

DESIGN 2
Ausfuehrung 2

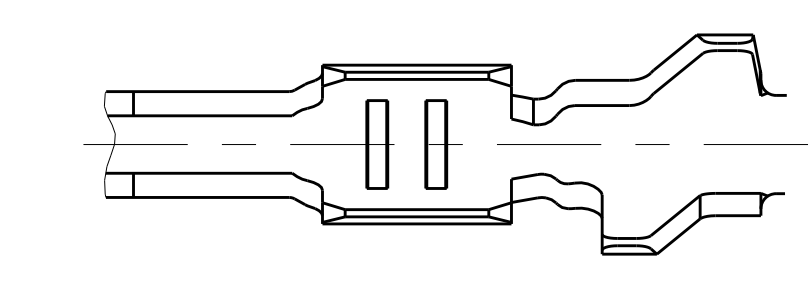
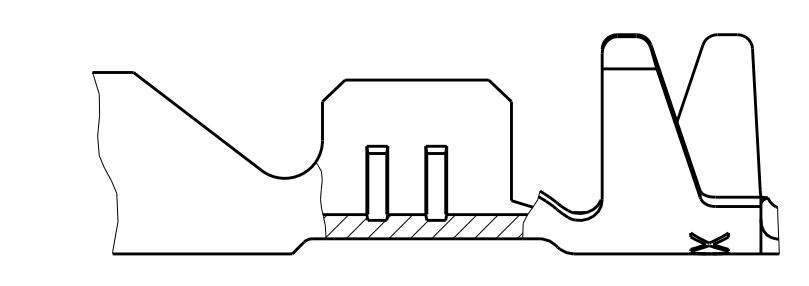

DESIGN 5
Ausfuehrung 5

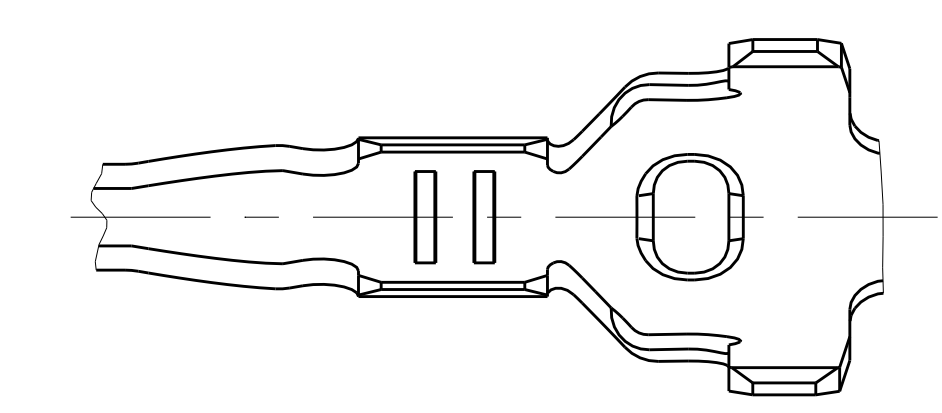
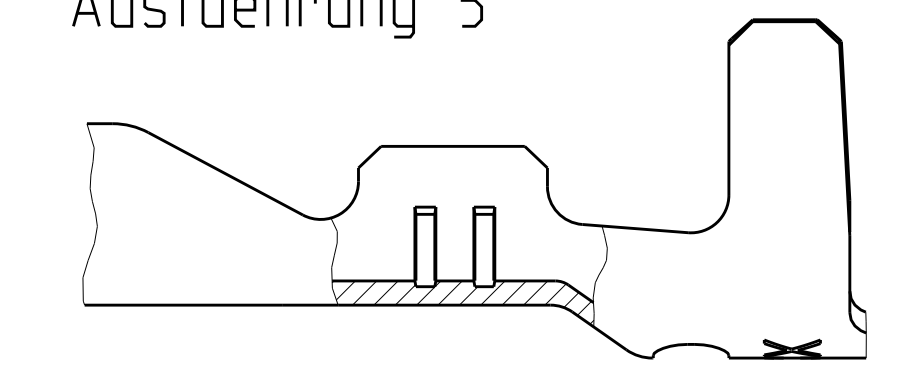

DESIGN 3
Ausfuehrung 3

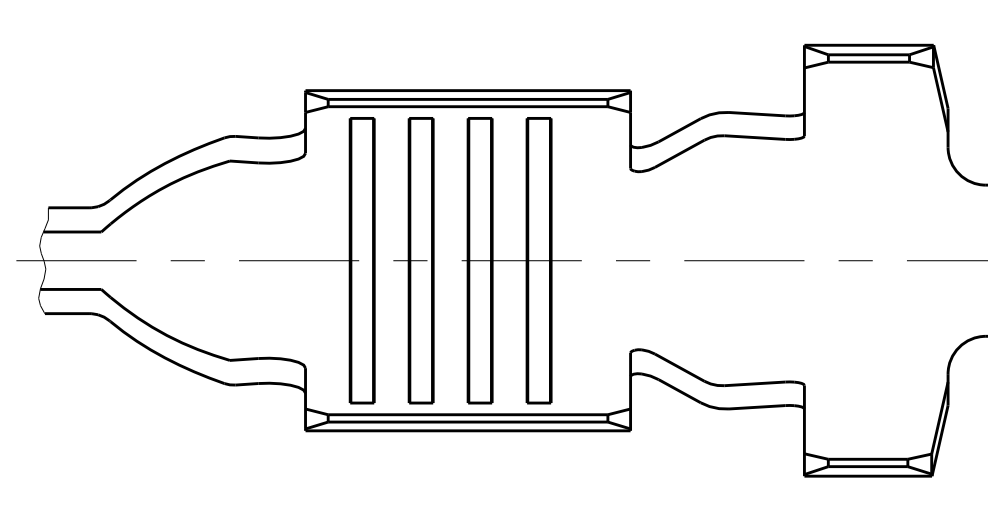
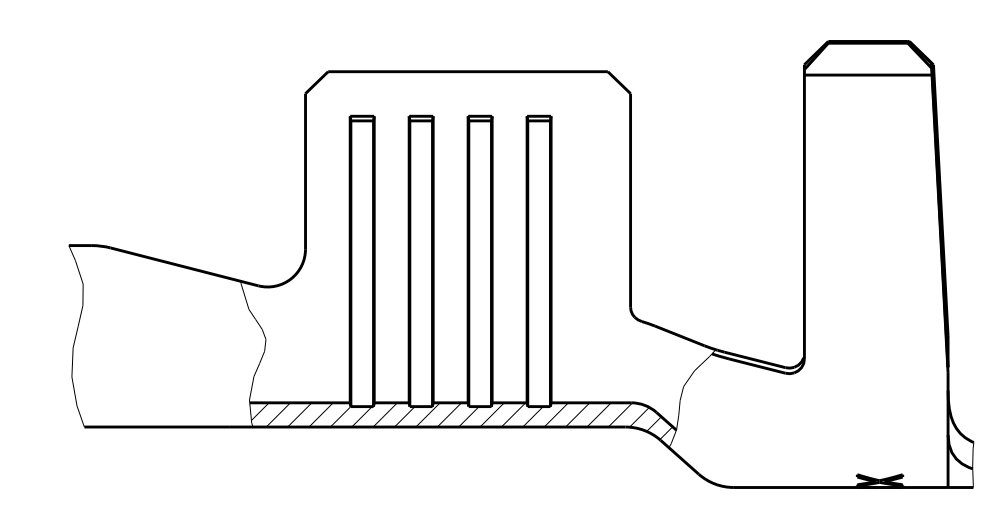

DESIGN 6
Ausfuehrung 6

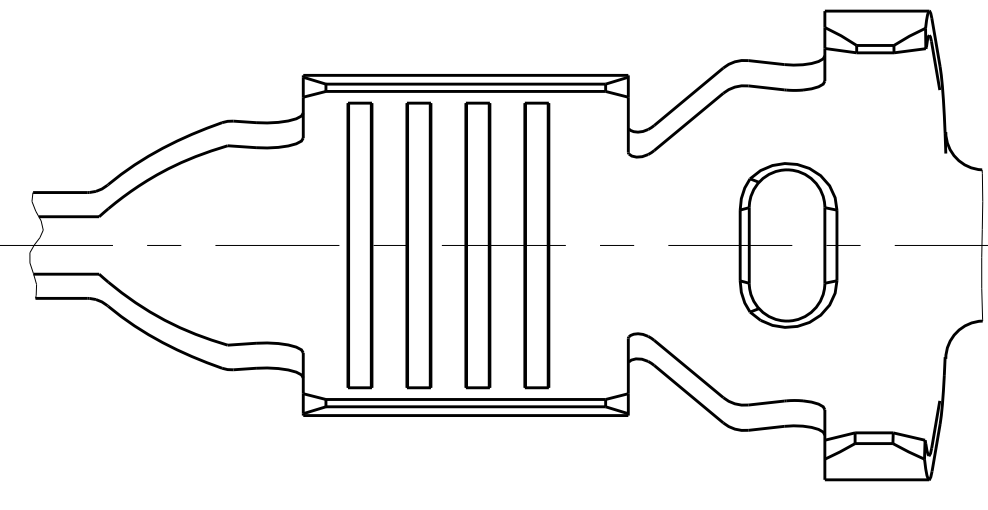
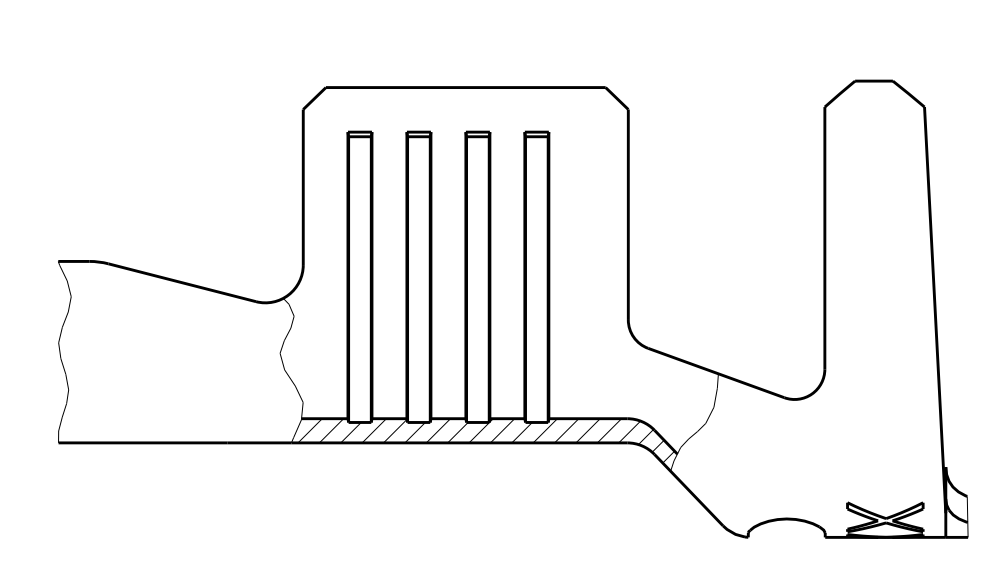

SINGLE WIRE SEAL / Einzeldichtungssystem	REV	DESIGN	MATERIAL	SURFACE	DGB	INSULATION	SEE / siehe	SEE / siehe	SEE / siehe	APPLICATION TOOL	HAND TOOL	A	B	C	D	TE	TE
							SECTION A-A Schnitt A-A	SECTION B-B Schnitt B-B	WIRE CRIMP Drahtcrimp								
1-1719504-2	A	4	CuSn4		12 AWG	max. 3.0	E = 4.0 G = 4.2 D _{Dr} = 2.0	H = 5.3 K = 5.0 D = 3.6	AWG 12 = 2.0	1852291-3	-	3.5	6.0	7.6	26.8	828922-1	
3-968947-1	A	4	CuSn0.20		FLR	max. 3.7	E = 4.5 G = 4.7 D _{Dr} = 2.3	H = 6.2 K = 6.0 D = 4.3	4.0 mm ² = 2.25	MQC APPLICATOR 2-541537-2	539635-1 MATRIZE : 539727-2	4.3	6.9	8.5	28.5	828985 (Ø6.4)	828986-1
2-968947-2	A	6	CuFe														
2-968947-1	A	6	CuSn4		FLR	max. 3.0	E = 3.6 G = 3.8 D _{Dr} = 1.7	H = 5.3 K = 5.0 D = 3.6	2.5 mm ² = 1.88 2.0 mm ² = 1.73 1.5 mm ² = 1.58	MQC APPLICATOR 2-878560-2	734440-1	3.5	6.0	7.6	26.8	828905 (Ø5.0)	
1-968947-2	A	6	CuFe														
1-968947-1	A	6	CuSn4		FLR	max. 2.1	E = 2.6 G = 2.9 D _{Dr} = 1.2	H = 5.0 K = 4.8 D = 3.3	1.0 mm ² = 1.36 0.75 mm ² = 1.27 0.5 mm ² = 1.18	MQC APPLICATOR 2-878559-2	734438-1	3.0	5.4	7.0	26.8	828904 (Ø5.0)	
2-962916-3	E	4	CuFe														
2-962916-2	E	4	CuSn4		FLR	max. 2.1	E = 2.1 G = 2.1 D _{Dr} = 0.8	H = 4.7 K = 4.5 D = 3.2	0.5 mm ² = 1.12 0.35 mm ² = 1.05 0.2 mm ² = 0.98	MQC APPLICATOR 2-878558-2	539635-1 MATRIZE : 539737-2	2.5	4.9	6.5	26.8	828904 (Ø5.0)	
2-962916-1	E	4	CuFe														
1-962916-3	E	4	CuSn4		FLR	max. 2.1	E = 4.5 G = 4.7 D _{Dr} = 2.3	H = 5.7 K = 5.9 D = 3.3	4.0 mm ² = 2.25	MQC APPLICATOR 2-541534-2	539635-1 MATRIZE : 539723-2	4.3	6.6	8.5	28.5		
1-962916-2	E	4	CuFe														
1-962916-1	E	4	CuSn4		FLK	2.4 - 3.7	E = 3.6 G = 3.8 D _{Dr} = 1.7	H = 5.5 K = 5.7 D = 3.2	2.5 mm ² = 1.88 2.0 mm ² = 1.73 1.5 mm ² = 1.58	MQC APPLICATOR 2-878552-2	734417-3	3.6	5.2	8.9	28.6		
2-962915-3	E	4	CuFe														
2-962915-2	E	4	CuSn4		FLR	2.1 - 2.9	E = 3.6 G = 3.8 D _{Dr} = 1.7	H = 4.3 K = 4.5 D = 2.6	2.5 mm ² = 1.88 2.0 mm ² = 1.73 1.5 mm ² = 1.58	MQC APPLICATOR 2-878551-2	734417-2	3.6	5.2	8.2	27.9		
2-962915-1	E	4	CuFe														
6-962915-6	E	4	CuSn4		FLR	1.4 - 2.1	E = 2.6 G = 2.8 D _{Dr} = 1.1	H = 3.2 K = 3.4 D = 1.8	1.0 mm ² = 1.36 0.75 mm ² = 1.27 0.5 mm ² = 1.18	MQC APPLICATOR 2-878550-2	734417-1	3.0	4.6	7.0	26.7		
1-962915-3	E	4	CuFe														
1-962915-2	E	4	CuSn4		FLR	1.3 - 1.6	E = 2.1 G = 2.1 D _{Dr} = 0.8	H = 2.9 K = 2.9 D = 1.4	0.5 mm ² = 1.12 0.35 mm ² = 1.05 0.2 mm ² = 0.98	MQC APPLICATOR 2-878549-2	734538-1	2.5	3.7	5.8	25.5		
1-962915-1	E	4	CuFe														
1-965982-3	A	5	CuSn4		0.2 - 0.5 FLR	max. 2.1	E = 2.1 G = 2.1 D _{Dr} = 0.8	H = 4.7 K = 4.5 D = 3.2	0.5 mm ² = 1.12 0.35 mm ² = 1.05 0.2 mm ² = 0.98	MQC APPLICATOR 2-878558-2	539635-1 MATRIZE : 539737-2	2.5	4.9	6.5	26.8	828904 (Ø5.0)	
1-965982-1	A	5	CuSn4		0.2 - 0.5 FLR	max. 2.1	E = 2.1 G = 2.1 D _{Dr} = 0.8	H = 4.7 K = 4.5 D = 3.2	0.5 mm ² = 1.12 0.35 mm ² = 1.05 0.2 mm ² = 0.98	MQC APPLICATOR 2-878558-2	539635-1 MATRIZE : 539737-2	2.5	4.9	6.5	26.8	828904 (Ø5.0)	

UNSEALED / ungedichtet

TE ORDER-NO.	DESIGN REV	MATERIAL	SURFACE	DGB	INSULATION	WIRE CRIMP	WIRE CRIMP	APPLICATION TOOL	HAND TOOL	A	B	C	D	TE ORDER-NO.
STRIPFORM Bandware	Ausfuehrung	Werkstoff	Oberflaeche	mm ²	mm	WIRE CRIMP Drahtcrimp	WIRE CRIMP Drahtcrimphoe CH	ANSCHLAGWERKZEUG	HANDZANGE					SEALING PLUG Blindstopfen
CRIMP DIMENSION mm Crimpabmessungen mm										EXTRACTION TOOL Ausdrueckwerkzeug No. 968107-1				

THIS DRAWING IS A CONTROLLED DOCUMENT. DATE: 14 JUN 1999. BY: K. Gerlach, CH. M. Bleicher, APPR: [Signature]

STE TE Connectivity
 PRODUCT GROUP DRAWING FOR TAB 2.8x0.8
 Produktgruppenzeichnung fuer Flachstecker 2.8x0.8

SCALE: 10:1 SHEET 1 OF 1