

REVISION RECORD				
REV	ECN	DESCRIPTION	DRFT	DATE

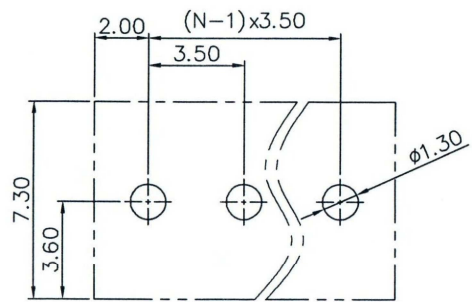

P.C.B LAYOUT

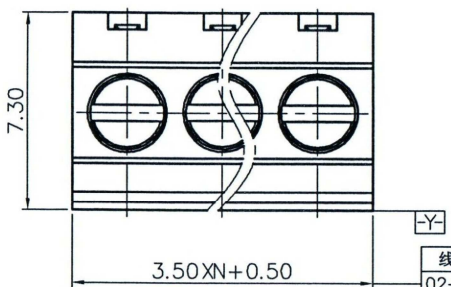

线数	总长公差(mm)
02-04P	±0.30
05-08P	±0.40

仅供参考图  
 签字: [Signature]  
 日期: [Date]

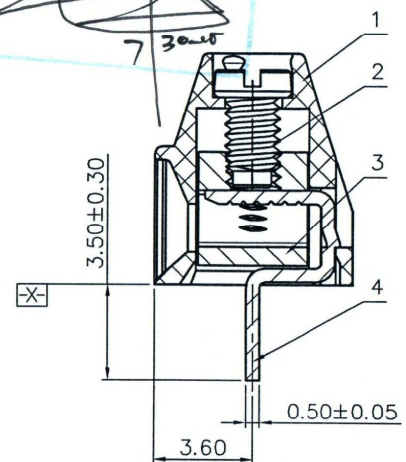
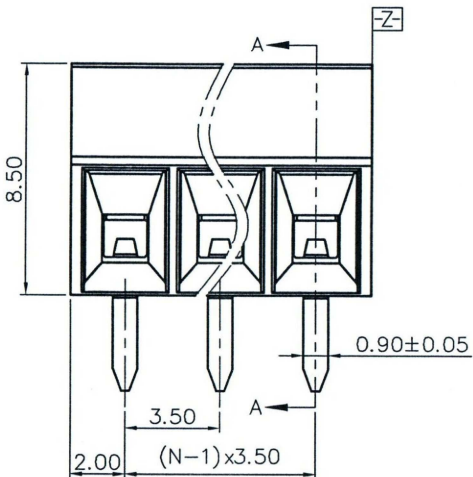
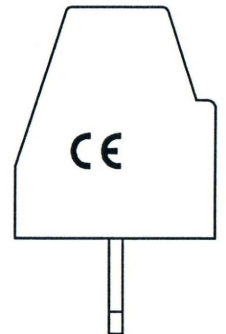

SEC A-A

- NOTES:  
 1.DIMENSION SHALL BE INTERPRETED PER ASME Y14.5-2009.  
 2.PITCH: 3.5 ,POLES:N=02-08P  
 3.UL1059: 150V/10A  
 4.IEC:

POLLUTION DEGREE	2	2	3
OVERVOLTAGE CATEGORY	II	III	III
RATED IMPULSE VOLTAGE(KV)	2.5KV	2.5KV	2.5KV
RATED VOLTAGE(V)	200V	200V	63V
RATED CURRENT(A)	13.5A	13.5A	13.5A

- 5.LOWER LIMIT TEMPERATURE: -40℃  
 6.UPPER LIMIT TEMPERATURE: +120℃  
 7.WIRE RANGE: 26AWG~16AWG,0.2MM<sup>2</sup>~1.5MM<sup>2</sup>  
 8.TORQUE VALUE:M2,1.77LB.IN/0.2N.M.  
 9.STRIPPING LENGTH: 5~6MM  
 10.UNDIMENSIONED TOLERANCES:

PITCH RANGE IN MM		NOMINAL DIMENSION RANGE IN MM						
TO	OVER	TO	OVER	TO	OVER	TO	OVER	
6	10	30	60	100	150	150	150	∩
10	24	30	60	100	150	150	150	□
±0.10	±0.15	±0.25	±0.20	±0.30	±0.50	±0.70	±1.00	0.05/10

ITEM	NAME OF PART	NO. OF PART	Q'TY	MATERIAL	NOTES
4	DG381-1000A Pin header	4047B00030(H)	XX	Phosphor bronze	Sn plated
3	DG381-1000A Cage	X000005070(H)	XX	Brass	Ni plated
2	DG381-1000A Screw	S000006220(H)	XX	Steel	Zn plated
1	DG381-THR-3.5-Housing	4227GYXXA(H)	1	PA4T	UL94V-0

DETACHED LISTS	MM (INCH)	MATERIAL:	宁波高正电子有限公司 DEGSON ELECTRONICS CO., LTD	
	TOLERANCES EXCEPT AS NOTED	FINISH:	PART NO.:	NAME:
	.X ± .XX ± .XXX ±	.X' ± .XX' ± .XXX' ±		DG381-THR-3.5-XXP-1Y-10A(H)
	ANGLES ± 1°	APPD: Aaron 7/30/14	TITLE: ASSEMBLY DRAWING	REV TO-1
THIRD ANGLE PROJECTION	CHKD:	DRFT: Jay.z 10/07/14"	DRAWING NO.: DG381-THR-3.5-E03	SHEET 1/1
		DO NOT SCALE DRAWING	SCALE N/A	