

CAV444

Linear C/V-Converter for capacitive input signals

Principle Function

Capacitance\Voltage-converter IC with linear transfer function and adjustable output

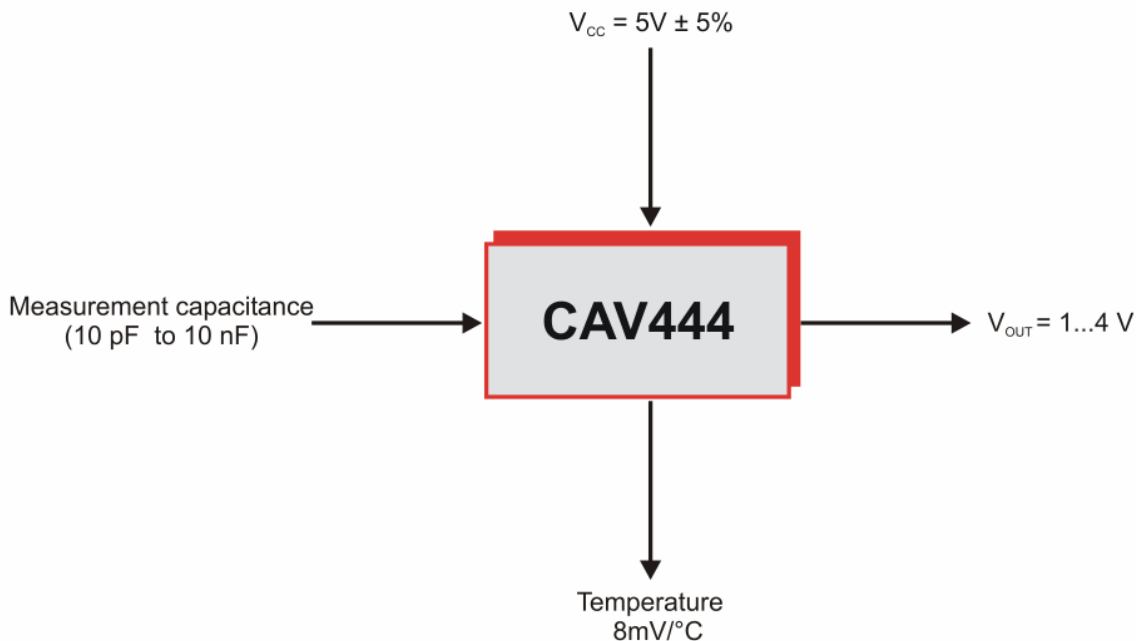

Function

CAV444 is an integrated circuit for capacitive sensing applications. The IC converts the connected input measurement capacitance into an output voltage, which is a linear function of the measurement capacitance.

CAV444 can be used as stand-alone analog signal-processing IC or as front-end for a micro processor for electronically calibratable sensor systems.

Typical Applications

- Humidity measurement
- Distance measurement
- Level sensing
- Material identification
- Object detection

CAV444

Linear C/V-Converter for capacitive input signals

CONTENTS

FEATURES.....	3
BLOCK DIAGRAM.....	3
GENERAL DESCRIPTION	3
SPECIFICATIONS	4
1. Electric Specifications	4
2. Absolute Maximum Values	5
APPLICATION INFORMATION	6
1. Functional Principle	6
2. Transfer Function	7
3. C/V-converter with adjustable gain and offset	8
4. Standard Dimensioning.....	9
5. Calibration Procedure	9
6. Operation Instructions	10
PACKAGE AND PINOUT.....	11
DELIVERY FORMS	11
ACCESSORIES.....	11
FURTHER LITERATURE.....	11
NOTES	12

CAV444

Linear C/V-Converter for capacitive input signals

FEATURES

- large measurement capacitance input range: 10pF up to 10nF
- ratiometric voltage output
- linear transfer function
- adjustable offset and gain
- fast response time
- measurement oscillator frequency: 1kHz-240kHz
- integrated temperature sensor
- supply voltage $5V \pm 5\%$
- large temperature range: $-40^{\circ}\text{C} \dots +105^{\circ}\text{C}$
- easy-to-use calibration procedure (Excel-sheet)
- available in SO16 or as die
- RoHS conform

GENERAL DESCRIPTION

CAV444 is an integrated C/V converter suitable for the signal-processing in capacitive sensor systems. Its output voltage is a linear function of the connected measurement capacitance C_M and ratiometric to the supply voltage.

The IC is completely analog leading to a fast response time and a resolution only limited by the signal to noise ratio.

CAV444 provides the complete electronics needed for the conversion of capacitive input signals into voltage output signals, which can be amplified and offset adjusted using external trimming resistors.

The IC can be used as stand-alone analog signal-processing IC or as front-end for a micro processor for electronically calibratable sensor systems.

An Excel-sheet simplifies the external component's dimensioning as well as the trimming of complete sensor systems.

BLOCK DIAGRAM

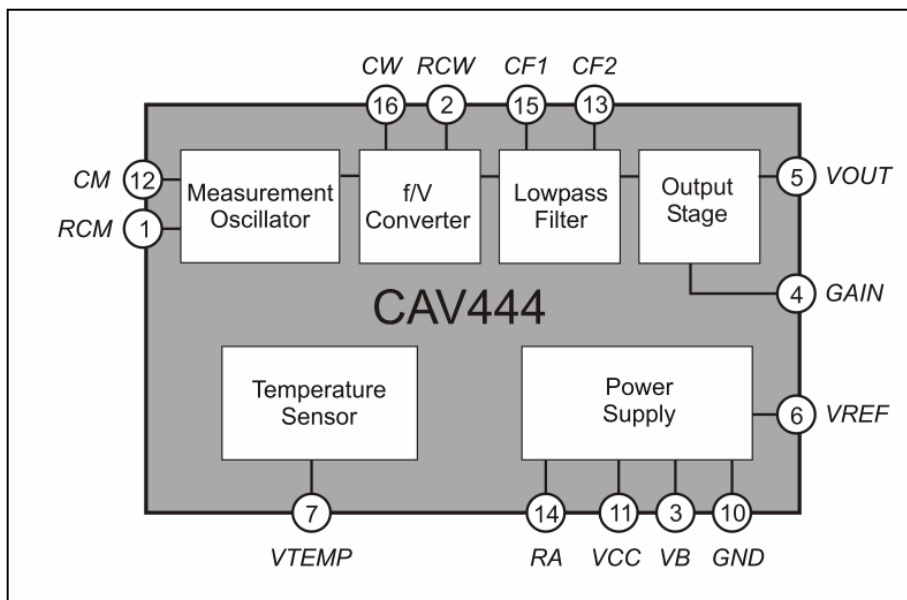

Figure 1: CAV444's block diagram

CAV444

Linear C/V-converter for capacitive input signals

SPECIFICATIONS

1. Electric Specifications

$T_{amb} = 25^{\circ}\text{C}$, $V_{CC} = 5\text{V}$, $I_{CM} = I_{CW} = 20 \mu\text{A}$ (unless otherwise noted)

Parameter	Symbol	Conditions	Min.	Typ.	Max.	Unit
System						
Operating Temperature	T_{amb}		-40		105	$^{\circ}\text{C}$
Supply Voltage	V_{CC}		4.75	5.00	5.25	V
Current consumption	I_{CC}	$T_{amb} = 25^{\circ}\text{C}$, $G = 1$ $T_{amb} = -40 \dots 105^{\circ}\text{C}$, $G = 1$			2 2.2	mA mA
Measurement Capacitance ¹⁾	C_M		10		10000	pF
Output Voltage ²⁾	V_{OUT}		1.0		4.0	V
Temperature Coefficient V_{OUT} ³⁾	TC_{VOUT}	$dV_{OUT}/(dT \cdot V_{Span}) @ T_{amb} = -40 \dots 85^{\circ}\text{C}$ $G = 1$, $C_W = 1.5 \text{ nF}$, $C_M = 0.1 \dots 1 \text{ nF}$			± 100	$\text{ppm}/^{\circ}\text{C}$
Maximum Input Signal Frequency ⁴⁾	$f_{SIG,max}$	@ $C_M = 10 \text{ pF}$, $R_{CM} = 125 \text{ k}\Omega$, $C_{F1} = 2 \text{ nF}$, $C_{F2} = 2 \text{ nF}$		3.5		kHz
Minimal Response Time ⁵⁾	$t_{RES,min}$	@ $C_M = 10 \text{ pF}$, $R_{CM} = 125 \text{ k}\Omega$ $C_{F1} = 2 \text{ nF}$, $C_{F2} = 2 \text{ nF}$		0.4		ms
Measurement Oscillator						
Oscillator Frequency Range	f_M	$f_M = V_{REF} / (2 \cdot \Delta V_{CM} \cdot R_{CM} \cdot C_M)$	1		240	kHz
Oscillator Voltage	ΔV_{CM}		2.1	2.15	2.2	V
Oscillator Current Resistor	R_{CM}		50		125	$\text{k}\Omega$
Oscillator Charge Current	I_{CM}	$I_{CM} = V_{REF} / R_{CM}$	20		50	μA
Oscillator Charge Current Spread	I_{CM}	@ $R_{CM} = 125 \text{ k}\Omega$	19	20	21	μA
f/V-Converter						
Converter Capacitor Range	C_W	$C_W = 1.4 \cdot C_{M,max} \cdot R_{CM} / R_{CW}$ @ $R_{CW} = 125 \text{ k}\Omega$, $R_{CM} = 125 \text{ k}\Omega$	14		14000	pF
Minimum Converter Voltage	$V_{CW,min}$	@ PIN 16	1.15	1.2	1.25	V
Maximum Converter Voltage	$V_{CW,max}$	@ PIN 16		4.1		V
Converter Current Resistor	R_{CW}		100		1250	$\text{k}\Omega$
f/V-Capacitor Charge Current	I_{CW}	$I_{CW} = V_{REF} / R_{CW}$	2		25	μA
f/V-Capacitor Charge Current Spread	I_{CW}	@ $R_{CW} = 125 \text{ k}\Omega$	19	20	21	μA
f/V-Stage Biasing Resistor	R_A	$R_A = 0.48 \cdot R_{CW}$, @ $R_{CW} = 125 \text{ k}\Omega$		60		$\text{k}\Omega$
Lowpass Stage						
Internal Low Pass Resistors	R_{01}, R_{02}			20		$\text{k}\Omega$
Low Pass Filter Capacitor ⁶⁾	C_{F1}, C_{F2}		2		1100	nF
Corner Frequency 1 (3 dB)	f_{CF1}	@ $C_{F1} = 2 \text{ nF}$		4		kHz
Corner Frequency 2 (3 dB)	f_{CF2}	@ $C_{F2} = 2 \text{ nF}$		4		kHz
Offset Voltage LP-Stage	V_{ofs}^{LP}		-2		2	mV

CAV444

Linear C/V-converter for capacitive input signals

Output Stage						
Adjustable Gain	G		1		10	
Output Current	I_{OUT}	Source, Sink ⁷⁾	-100		100	μA
Differential Output voltage	V_{DIFF}	$V_{Diff} = V_{out} - V_{REF}$	-1.5		1.5	V
Resistive Load at Pin V_{OUT}	R_L		40			k Ω
Capacitive Load at Pin V_{OUT}	C_L				100	pF
Input Offset Voltage	V_{OFS}	$R_L = 100\text{M}\Omega$	-2		+2	mV
Voltage Reference V_{REF}						
Reference Voltage	V_{REF}		2.49	2.5	2.51	V
V_{REF} vs. Temperature	TC_{VREF}	$dV_{REF}/(dT \cdot V_{REF}), T_{amb} = -40...+85^\circ\text{C}$			± 50	ppm/ $^\circ\text{C}$
Output Current	I_{VREF}	Source, Sink ⁷⁾	-100		100	μA
Load Capacitance	C_{VREF}		80	100	120	nF
Temperature Sensor V_{TEMP}						
Output Voltage	V_{TEMP}	@ $T_{amb} = 25^\circ\text{C}, R_{Load} \geq 50\text{M}\Omega$	2.20	2.32	2.45	V
Sensitivity	S	$S = dV_{TEMP}/dT, R_{Load} \geq 50\text{M}\Omega$		8		mV/ $^\circ\text{C}$
Resistive Load	R_{Load}		10			M Ω
Thermal Nonlinearity		$R_{Load} \geq 50\text{M}\Omega, T_{amb} = -25 \dots 85^\circ\text{C}$		0.5		%

Table 1: CAV444's electric specifications

Notes:

- 1) For linearity better than 0.3% (BFSL) it is recommended to use a maximum measurement capacitance $C_{M,max}$ not larger than ten times the particular minimum measurement capacitance $C_{M,min}$.
- 2) If $V_{CC} \neq 5\text{ V}$, the maximum of V_{OUT} is given by $0.8 \cdot V_{CC}$.
- 3) The temperature coefficient is normalized with $V_{Span} = V_{Out}(C_{M,max}) - V_{Out}(C_{M,min})$. TC_{VOUT} is increased, if C_M (C_W) is decreased.
- 4) The maximum input signal frequency $f_{SIG,max}$ is defined as the measurement capacitance's change rate, at which the low pass filter reduces the output voltage by 6 dB. In general $f_{SIG,max}$ depends on the choice of values of C_{F1} and C_{F2} and can be increased if C_{F1} and C_{F2} are decreased (see note 6 below).
- 5) CAV444's response time can be decreased if smaller low pass capacitors C_{F1} and C_{F2} are chosen.
- 6) The typical dimensioning of the low pass capacitors C_{F1} and C_{F2} is based on the requirement that a ripple of less than 1 ‰ remains at the highest oscillator frequency. Smaller capacitances can be chosen but lead to a higher ripple.
- 7) Currents flowing into the IC have a negative sign.

2. Absolute Maximum Values

Parameter	Symbol	Condition	Min.	Typ.	Max.	Unit
Maximum Supply Voltage	V_{CCmax}				6	V
Maximum Oscillator Charge Current	I_{CMmax}				50	μA
Maximum f/V-Capacitor Charge Current	I_{CWmax}				25	μA
Storage temperature	T		-55		125	$^\circ\text{C}$
ESD Susceptibility ¹⁾	V_{ESD}	HBM			2	kV

Table 2: Absolute Maximum Values

Notes:

- 1) ESD Protection on all pins except pin 12, pin 14 and pin 16.

CAV444

Linear C/V-converter for capacitive input signals

APPLICATION INFORMATION

1. Functional Principle

CAV444's functional principle is described using *Figure 2*, where the functional blocks of the IC, the signal patterns inside the IC and a basic external wiring with necessary passive components are shown.

The IC consists of six functional blocks: the measurement oscillator, the f/V converter, the low pass filter, the output stage, the temperature sensor and the power supply. The power supply block drives all the other blocks and also generates a reference voltage of 2.5 V. The temperature sensor block provides an output voltage V_{TEMP} proportional to the IC's temperature. The capacitance measurement path consists of the remaining four blocks and is described below.

CAV444 uses the following measurement principle: The input measurement capacitance C_M , connected at pin 12, works as the capacitor of the measurement oscillator block. C_M is charged and discharged periodically with constant current by CAV444. At the measurement oscillator's output a triangular voltage with constant amplitude is generated. The frequency of this triangular voltage (measurement oscillator frequency f_M) depends on the connected measurement capacitance C_M . Using the f/V converter block and the following low pass filter block the triangular voltage is converted into a DC voltage, which can be impedance transformed or amplified at the output stage. Furthermore the output signal's offset can be adjusted by using the circuit in *Figure 4*. The output voltage V_{OUT} at pin 5 (referenced to *GND*) is ratiometric to the supply voltage and a linear function of C_M ¹

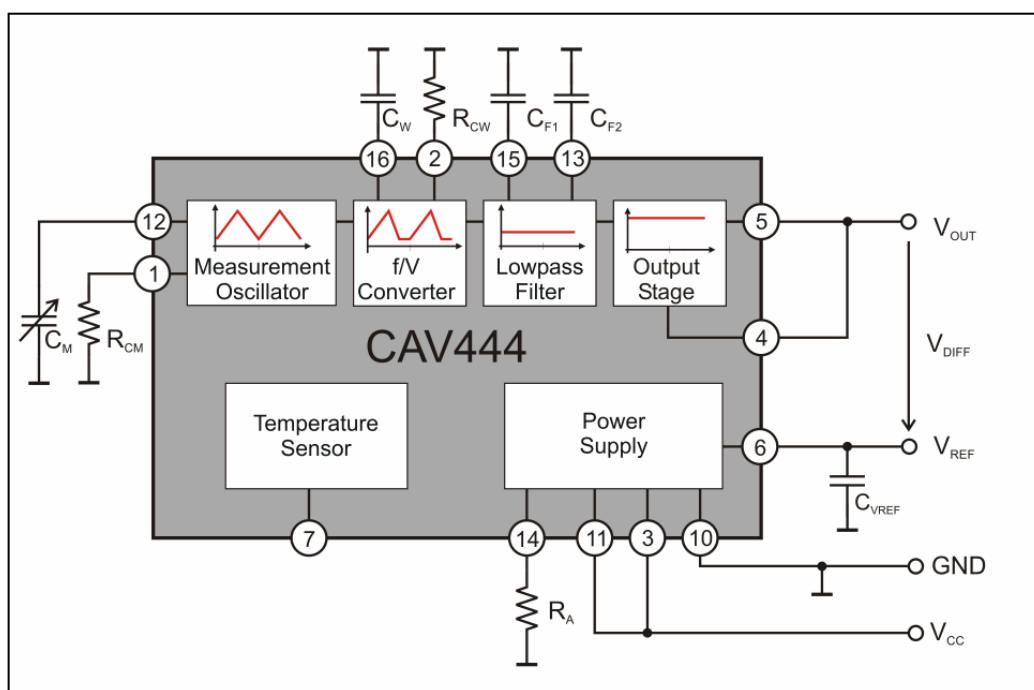

Figure 2: CAV444 with signal path and a basic circuit

¹ If the differential output voltage $V_{DIFF} = V_{OUT} - V_{REF}$ is evaluated and if no further offset adjustment is done, V_{DIFF} is directly proportional to C_M .

CAV444

Linear C/V-converter for capacitive input signals

2. Transfer Function

The system shown in *Figure 2* can be used as basic circuit for the CAV444. The output voltage V_{OUT} at pin 5 (referenced to GND) is given by:

$$V_{OUT}(C_M) = V_{LPAS}(C_M) + V_{REF} = \left(\frac{3 \cdot \Delta V_{CM} \cdot R_{CM}}{8 \cdot C_W \cdot R_{CW}} \right) \cdot C_M + V_{REF} \quad (1)$$

with

V_{LPAS} = low-pass voltage

V_{REF} = reference voltage (with $V_{REF} = 2.5$ V)

C_W = f/V converter capacitance

C_M = measurement capacitance

ΔV_{CM} = voltage amplitude at the measurement capacitance (with $\Delta V_{CM} \approx 2.1$ V)

R_{CM} = oscillator current resistor

R_{CW} = reference current resistor

R_{CM} and R_{CW} define the charge currents $I_{CM} (=V_{REF}/R_{CM})$ and $I_{CW} (=V_{REF}/R_{CW})$ for the input capacitance C_M and the converter capacitor C_W . A typical dimensioning for these fixed resistors is $R_{CM} = R_{CW} = 125$ k Ω .²

C_W 's dimensioning is given by:

$$C_W = 1.4 \cdot \frac{R_{CM} \cdot C_{M,max}}{R_{CW}} \quad (2)$$

wherein $C_{M,max}$ is the particular used maximum measurement capacitance. Combining (1) and (2) leads to

$$V_{OUT}(C_M) = \frac{9}{16} \cdot \frac{C_M}{C_{M,max}} + V_{REF} \quad (3)$$

The output voltage given by equation (3) is a linear function of C_M and is illustrated in *Figure 3*. A minimum measurement capacitance $C_{M,min} \neq 0$ leads to a minimum output voltage $V_{OUT}(C_{M,min}) > V_{REF}$.

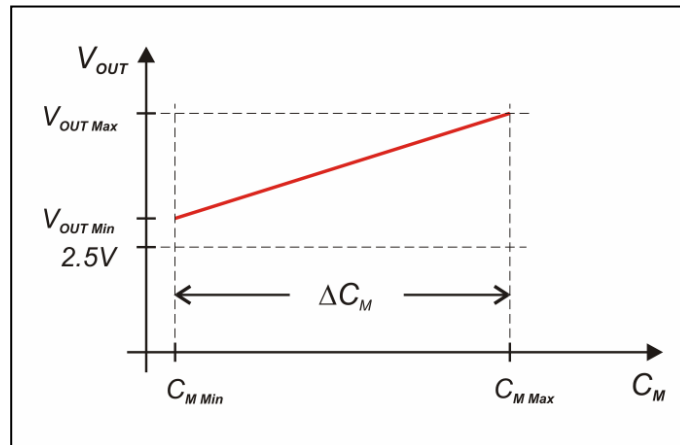

Figure 3: Output signal V_{OUT} as a function of the measurement capacitance C_M

If instead of V_{OUT} the differential voltage V_{DIFF} between pin 5 and pin 6 is evaluated, the output signal is directly proportional to C_M .

$$V_{DIFF}(C_M) = V_{OUT}(C_M) - V_{REF} = \frac{9}{16} \cdot \frac{C_M}{C_{M,max}} \quad (4)$$

² For an optimal and easy dimensioning of the external passive components Analog Microelectronics has developed the Excel-tool, Kali_CAV444 (see section "Further Literature").

CAV444

Linear C/V-converter for capacitive input signals

3. C/V-converter with adjustable gain and offset

For the adjustment of the output signal's offset and gain five resistors $R_1 \dots R_5$ have to be added to the network in *Figure 2*. The complete measurement circuit with CAV444 is illustrated in *Figure 4*.

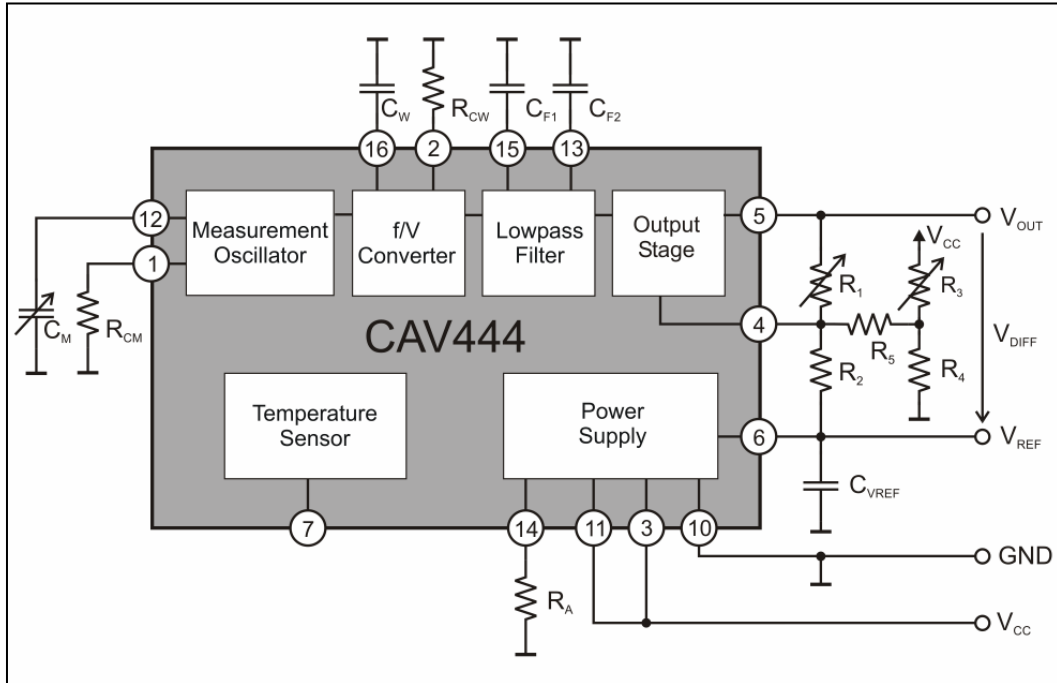

Figure 4: CAV444 used as C/V-converter with adjustable gain and offset

For the capacitive measurement system in *Figure 4* the output voltage V_{OUT} at pin 5 (referenced to *GND*) is given by:

$$V_{OUT} = G \cdot V_{LPAS} + B \cdot V_{REF} \quad (5)$$

with

$$G = 1 + \frac{R_1}{R_2} + \frac{R_1}{R_5} \cdot \frac{R_3 R_5 + R_4 R_5}{R_3 R_4 + R_4 R_5 + R_3 R_5} \quad \text{and} \quad B = 1 + \frac{R_1}{R_5} \cdot \frac{R_3 R_5 - R_4 R_5}{R_3 R_4 + R_4 R_5 + R_3 R_5} \quad (6)$$

wherein R_2 , R_4 and R_5 are fixed resistors,
 R_1 is the trimming resistor for the adjustment of gain and
 R_3 is the trimming resistor for the adjustment of offset.³

Using the equations (1), (5) and (6) it is easy to see that the output voltage is again a linear function of the measurement capacitance C_M .

$$V_{OUT}(C_M) = G \cdot \left(\frac{3 \cdot \Delta V_{CM} \cdot R_{CM}}{8 \cdot C_W \cdot R_{CW}} \right) \cdot C_M + B \cdot V_{REF} \quad (7)$$

With the standard dimensioning for C_W (see equation (2)) the output voltage is given by:

$$V_{OUT}(C_M) = G \cdot \frac{9}{16} \cdot \frac{C_M}{C_{M,max}} + B \cdot V_{REF} \quad (8)$$

³ The final values of R_1 and R_3 depend on the desired output voltage as well as on the individual sensor setup. In addition variances of the components (like manufacturing tolerances in R_{CM} , R_{CW} , C_W , $C_M \dots$) and the parasitic capacitances also influence the value of R_1 and R_3 (see section "Calibration Procedure").

CAV444

Linear C/V-converter for capacitive input signals

4. Standard Dimensioning

A basic dimensioning of the passive external components in *Figure 4* with a measurement capacitance not larger than 1 nF is given in the table below. For the application specific capacitance ranges an optimal dimensioning can be calculated using the Excel-sheet *Kali_CAV444*.

Parameter	Symbol	Min.	Typ.	Max.	Unit
Output Stage Resistors (1%)	R_2, R_4, R_5		100		k Ω
Gain Resistor (0.1%) Calibration Start Value ¹⁾	R_1		33		k Ω
Offset Resistor (0.1%) Calibration Start Value ¹⁾	R_3		100		k Ω
f/V-Stage Biasing Resistor	R_A		60		k Ω
Measurement Oscillator Current Resistor	R_{CM}		125		k Ω
f/V-Stage Current Resistor	R_{CW}		125		k Ω
Low Pass Filter Capacitors (depends on value of $C_{M,max}$) ³⁾	C_{F1}, C_{F2}		1000		nF
Reference Voltage capacitor ($V_{REF} = 2,5V$) ⁴⁾	C_{VREF}	80	100	120	nF
f/V converter capacitor	C_W		$1.4 * C_{M,max}$		pF

Table 3: Standard values for external components at $I_{CM} = I_{CW} = 20 \mu A$, $C_{M,max} < 1nF$

Notes:

- 1) The given values for the trimming resistors R_1 and R_3 are the initial values at the start of the trimming process. During the trimming process R_1 and R_3 will be set to individual values (calculated by the Excel-sheet *Kali_CAV444*).
- 2) In many applications it is sufficient to use standard components, like e-series capacitors and resistors with low temperature coefficients (≤ 100 ppm). For R_{CM} , R_{CW} , R_A , C_{VREF} and $C_{F1/F2}$ a variance of 5% of the given value is acceptable without a decrease in performance. For components, which have to have lower variances, the tolerances are given in round brackets in *Table 3*.
- 3) C_{F1} and C_{F2} depend on the minimum measurement capacitance $C_{M,min}$ and are calculated in such a way, that only a ripple of less than 1‰ remains at the highest oscillator frequency f_M .
- 4) For best performance a high grade ceramic capacitor has to be used for C_{VREF} .

5. Calibration Procedure

During the design of capacitive sensor systems it always has to be taken into account that there are parasitic capacitances beside the measurement capacitance, which influence the output signal and the calibration process. To simplify the consideration of these effects and to assist the user during the calibration of sensor systems based on the circuit in *Figure 4*, Analog Microelectronics developed a calibration strategy, implemented in the Excel-sheet *Kali_CAV444*. This Excel-sheet is available at www.analogmicro.de.

Using the Excel-sheet *Kali_CAV444* the calibration of capacitive sensor systems with CAV444 is done in two steps, a dimensioning and a trimming step. At first a dimensioning of the passive external components is calculated for the specific type of sensor implemented with CAV444. This dimensioning is mostly dependent on the capacitive measurement range of the sensor. Only the minimum and the maximum measurement capacitances as well as the desired differential output voltage and the charge currents I_{CM} and I_{CW} are needed for the calculation. Based on this input values the program calculates a suitable dimensioning of the external components, which can be used to assemble this type of sensor system.

After the specific sensor systems have been built with the calculated dimensioning, a trimming of offset and gain (using the trimming resistors R_1 and R_3) of the individual sensor systems has to be done. Therefore the output voltage has to be measured at the minimum and the maximum measurement capacitance. Based on these values the Excel-sheet calculates the final trimming resistor values for R_1 and R_3 . After trimming R_1 and R_3 to the calculated values the sensor is ready for operation and all parasitic capacitances as well as the tolerances of the used components are taken into account.

CAV444

Linear C/V-converter for capacitive input signals

6. Operation Instructions

It is recommended to do the external component's dimensioning using the Excel-sheet Kali_CAV444. In general the absolute maximum values in *Table 2* should not be exceeded. For first investigations Analog Microelectronics offers the BBCAV444, a pre-assembled breadboard (see accessories) with easily adaptable measurement capacitance ranges, which can be used to study the behavior of capacitance sensor heads as well.

To realize the dimensioning calculated by the Excel-sheet networks of not more than two resistors or capacitors should be used. In many applications it is sufficient to use standard components, like e-series capacitors, which fit to the calculated values within 5% (see section "Standard Dimensioning")

For the PCB layout it is recommended to place C_M and C_W as close to the IC as possible and to keep conducting lines from the IC to its external passive components short, leading to small parasitic capacitances.

The parasitic capacitances inside the IC and in the sensor setup enlarge the used capacitances, especially the measurement and converter capacitance. This influences the capacitance measurement directly. Therefore it is important to keep the parasitic capacitances stable (e.g. no flexible wiring).

A capacitor can be added in parallel to the measurement capacitance to measure capacitances smaller than the specified 10 pF. But in some cases the parasitic capacitances in the measurement setup are already large enough, making the additional capacitance unnecessary. Adding a capacitance in parallel to the measurement capacitance can also be advantageous if the ratio of the used maximum and minimum measurement capacitances $C_{M,max}/C_{M,min}$ is larger than ten to increase CAV444's linearity.

In real sensor applications the temperature behavior is mainly influenced by C_M 's, C_W 's and further external component's temperature coefficients. In general an optimal temperature behavior can be achieved by using C_M and C_W with equal temperature coefficients (TC). Because CAV444's temperature coefficient increases for small measurement capacitances it can be useful to shift the measurement capacitance range to higher values by connecting an additional capacitor in parallel to the measurement capacitance.

In general ESD precautions are necessary during assembly and handling of the device. It is essential to ground machines and personnel properly.

Notes:

1. If the voltage signal at pin 12 or 16 is measured, the probe's capacitance is added to the capacitance at the specific pin, which changes the output voltage signal. If measured at pin 12 the oscillator frequency is decreased and if measured at pin 16 the signal amplitude at the f/V-converter is reduced. To check the frequency and the signal amplitude after the f/V-converter without influencing the output signal it is possible to remove the low pass capacitor C_{F1} and measure at pin 15.
2. For level sensing applications it is important to isolate the measurement electrodes from a conductive medium. Otherwise the output voltage is affected by the conductivity of the medium.

CAV444

Linear C/V-converter for capacitive input signals

PACKAGE AND PINOUT

The CAV444's standard packaging is a SO16 (n) package (for dimensions please see the packaging catalog <http://www.analogmicro.de/products/analogmicro.de.en.package.pdf>).

PIN	NAME	DESCRIPTION
1	RCM	oscillator current adjustment
2	RCW	f/V converter current adjustment
3	VB	bias voltage connected to V _{CC}
4	GAIN	gain adjustment
5	VOUT	output voltage
6	VREF	reference voltage ca. 2.5V
7	VTEMP	temperature sensor voltage output
8	N.C.	not connected
9	N.C.	not connected
10	GND	IC ground
11	VCC	supply voltage
12	CM	measurement capacitance
13	CF2	2 nd order lowpass capacitor
14	RA	stabilizing resistor f/V converter
15	CF1	1 st order lowpass capacitor
16	CW	f/V converter capacitor

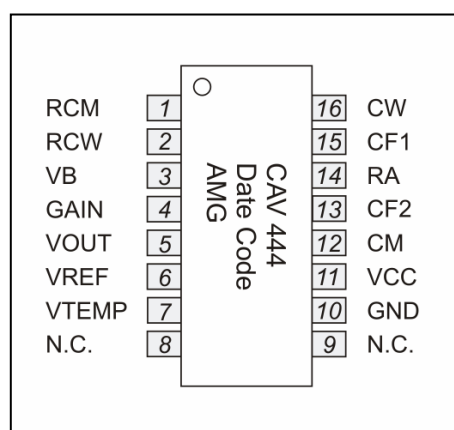

Table 4: Pin assignment CAV444 SO16 Package

DELIVERY FORMS

CAV444 is available as:

ORDER NUMBER	DELIVERY FORM
CAV444-0-SO16	CAV444 inside SO16 packaging
CAV444-WAF	sawn wafer on 8" blue foil
CAV444-Adapt	CAV444 soldered to a SO16-DIL16 adapter

ACCESSORIES

To support developments using CAV444 Analog Microelectronics GmbH offers the Breadboard BBCAV444.

ORDER NUMBER	DELIVERY FORM
BBCAV444	BBCAV444 - BreadBoard (PCB with CAV444)

FURTHER LITERATURE

1. Calibration tool Kali_CAV444.xls (<http://www.analogmicro.de/german/products/cav444.htm>)
2. Package catalog (<http://www.analogmicro.de/products/analogmicro.de.en.package.pdf>)
3. Application Notes on CAV444 (on request)
4. CAV444 - Die Size and Padout (on request)

CAV444

Linear C/V-converter for capacitive input signals

NOTES

Analog Microelectronics GmbH reserves the right to amend any dimensions, technical data or other information contained herein without prior notification.
