

V. Repair and maintenance

All repairs of the BISTABLE RELAY BR-10 are performed by the manufacturer. The device does not require any maintenance.

VI. Warranty Card

The manufacturer guarantees the correct operation of the BISTABLE RELAY BR-10. The warranty period is 36 months from the date of sale. The warranty is extended by the time of repair. Warranty repairs are performed by the manufacturer free of charge after the AUTOMAT is delivered to the manufacturer. Improper use of the device or independent modifications to it will void the warranty.



The BISTABLE RELAY BR-10 meets the requirements of the European Union Directives
- Directive LVD 2014/35/EU - Low Voltage Directive of 26 February 2014
- Directive EMC 2014/30/EU - Electromagnetic Compatibility Directive of 26 February 2014



In order to protect the environment, do not throw away used electrical appliances and electronics together with municipal waste. Used equipment should be delivered to collection points for recycling free of charge. Any information on this can be obtained at sellers, distributors, manufacturer or on the Internet. The product's packaging is made of ecological materials. The PVC packaging tape will be used while stocks last.



MADE IN EUROPE

BISTABLE RELAY BR-10

3-YEAR
WARRANTY



User manual

I. Purpose

The BISTABLE RELAY BR-10 is designed to turn the receiver on or off with an impulse button (e.g. a single-pole bell switch). Each subsequent pressing of the impulse button causes the change of the status of the executive relay. If the receiver was turned on, pressing the button momentarily turns the receiver off and vice versa.

The BISTABLE RELAY BR-10 allows you to turn the receiver on and off with many parallel connected impulse buttons, which means that the receiver can be turned on or off from anywhere.

The BISTABLE RELAY BR-10 can work with an unlimited number of impulse buttons (without backlight) connected in parallel and with a limited number of impulse illuminated buttons.

II. Properties of the BR-10 BISTABLE RELAY

- >> short response time to pressing <50ms
- >> short standby time for the next press <200 ms
- >> high switching power - 16A (4000 W), 250VAC
- >> high inrush current - resistance to 100 A surge current
- >> freedom of connections:
 - > executive relay contacts (one normally open contact - NO, one normally closed contact - NC) galvanically separated, which allows connections in various configurations
- >> traffic light (LED):
 - > Green LED - indication of 230V AC supply voltage on LN terminals
 - > LED red - signalling of short circuit contacts 1-2
 - > Blue LED - signalling of short-circuited contacts 2-3
- >> mounting on 35 mm DIN rail.

The BISTABLE RELAY BR-10 uses a specialized OMRON G2RL-1-E-HR relay, designed to switch various types of lighting lamps. The special design of the relay enables effective switching of lamps with an inrush current up to 100 A.

III. Installation

The BISTABLE RELAY BR-10 may only be connected by a person authorized to operate electrical installations. Remember to choose the right protection.

On the front of the BR-10 BISTABLE RELAY, there are three LED indicators: green, red and blue.

On the side walls of the BR-10 BISTABLE RELAY there are: connection diagram and operating characteristics.

In order to connect the BISTABLE RELAY BR-10:

1. make sure the electrical system is turned off
2. connect the RELAY according to the diagram (fig.2, fig.3) in the options:
 - > S1 control signal from L voltage
 - > S1 control signal from voltage N
 - > when using terminals 1-2 - after switching on, the receivers are turned off
 - > when using terminals 2-3 - after switching on, the receivers are turned on
3. switch on the supply voltage:
 - > the green LED lights up
 - > after 1 s red LED and blue LED will blink
 - > after 2 seconds, the blue LED will light up, which indicates closed contacts 2-3
4. Press the TEST button
 - > the blue LED turns off and the red LED turns on
 - > contacts 2-3 will open and contacts 1-2 will close
5. check operation with impulse button
 - > each subsequent press changes the voltage state on the receiver and changing the LED lighting:
 - blue - contacts 2-3 closed
 - red - contacts 1-2 closed
6. the efficiently operating installation is ready for operation
7. the pause between successive presses should not be less than 200 ms.
8. A schematic diagram of the operation of the BISTABLE RELAY BR-10 is shown in Fig. 1.

The BISTABLE RELAY BR-10 can work with an unlimited number of non-illuminated buttons and a limited number of illuminated buttons:

- buttons illuminated with a typical neon (1mA) <10 pcs.
- LED illuminated buttons (0.1mA) <100 pcs.

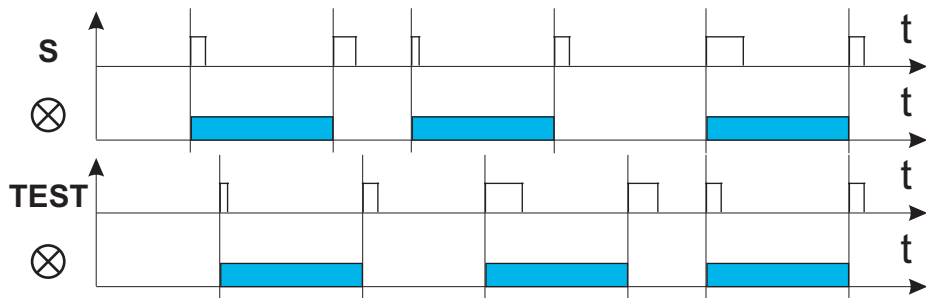

Fig. 1. Schematic diagram of the operating principle of the BISTABLE RELAY BR-10.

IV. Technical data

Rated supply voltage LN	230 V AC, + 10%, - 15%
Rated frequency	50 Hz
Maximum load current (power):	
> resistive load	16 A, AC1 (4 000 W)
> incandescent lamps	10 A (2500 W)
> halogen lamps	8 A (2000 W)
> fluorescent lamps	8 A (2000 W)
> energy-saving lamps and LED	8 A (2000 W)
Instantaneous inrush current	100A
Executive contacts	1 x NO, 1 x NC
Rated power consumption	0,5 W
Short-circuit current of impulse buttons	5 mA
Response time to the impulse button	< 40 ms
Time to be ready again	< 200 ms
Function check	TEST button
Mechanical durability	100 000 operations
Protection level	IP 20
Work position	Vertical
Installation	One 18 mm field, 35 mm rail
Cross-section of connection cables	0,2+2,5 mm ²
Working temperature	-25...+50 °C
Weight	80 g

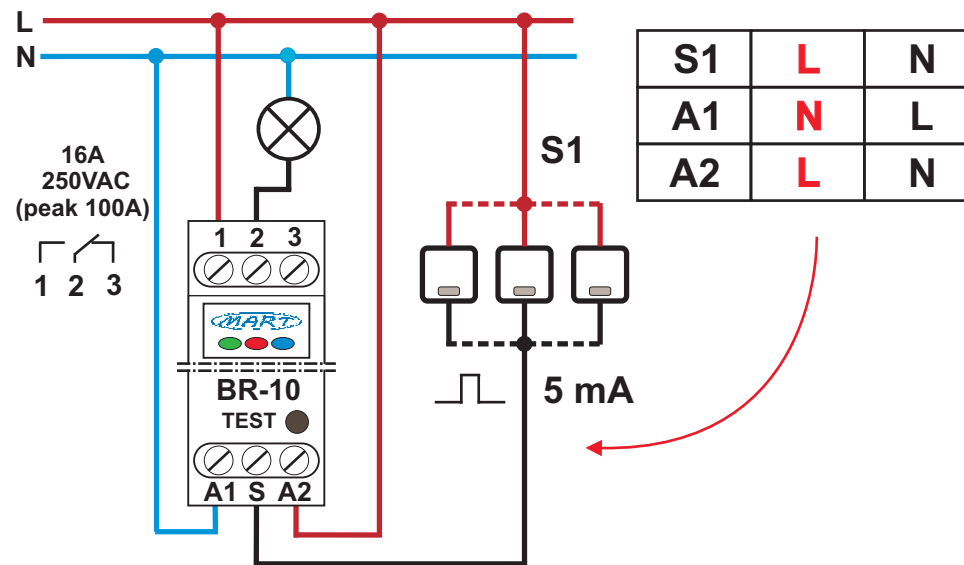

Fig. 2. An exemplary diagram of the connection of the BISTABLE RELAY BR-10 along with a table of possible connection variants.

Diagrams of possible variants of BR-10 connections are shown in Fig. 3.

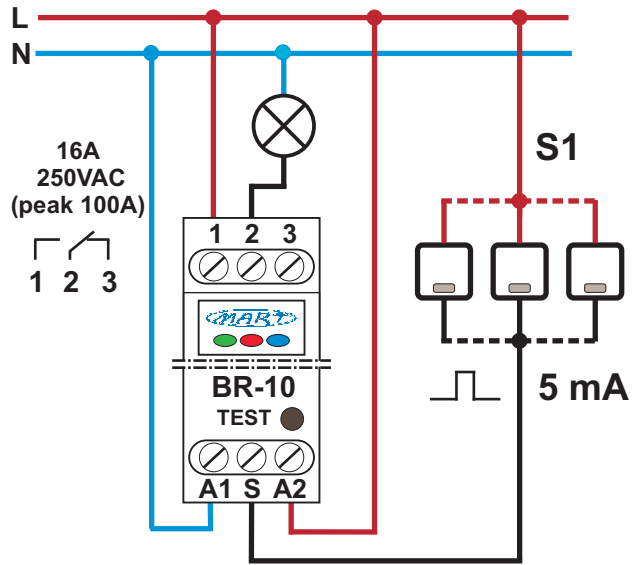

Fig. 3-1. Connection diagram of the BR-10 BISTABLE RELAY
 > L signal control on S clamp
 > after turning the power on (N-L) - the receiver is off

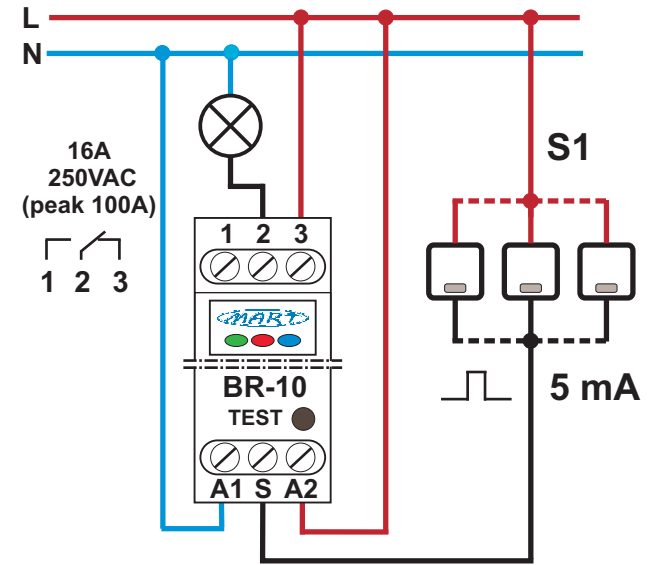

Fig. 3-2. Connection diagram of the BR-10 BISTABLE RELAY
 > L signal control on S clamp
 > after turning on the power (N-L) - the receiver is on

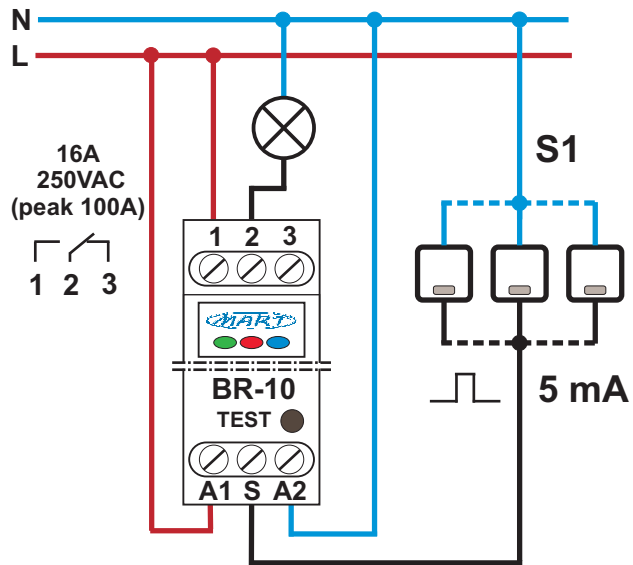

Fig. 3-3. Connection diagram of the BR-10 BISTABLE RELAY
 > N signal control on S clamp
 > after turning the power on (N-L) - the receiver is off

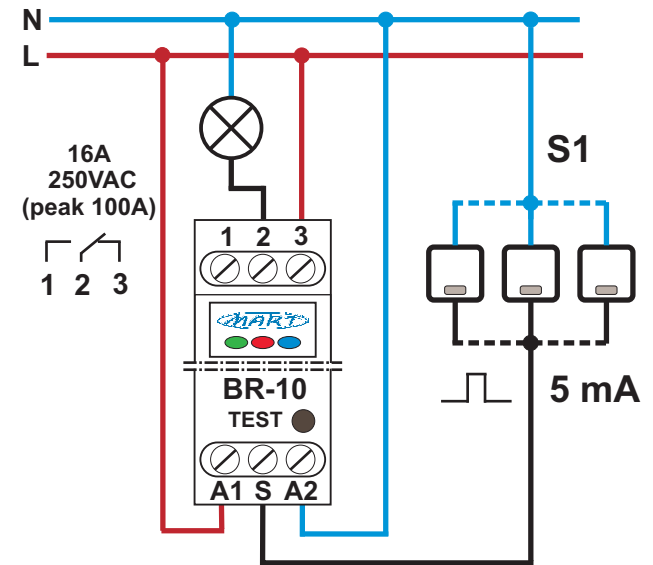

Fig. 3-4. Connection diagram of the BR-10 BISTABLE RELAY
 > N signal control on S clamp
 > after turning on the power (N-L) - the receiver is on