

Speed clips nuts for self-tapping screws

BN 30339

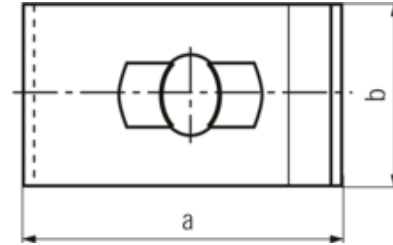
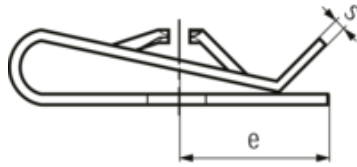
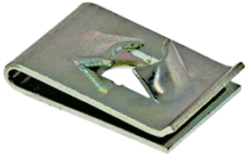

Brandtype SNU
 Material Spring steel
 Surface zinc plated

Illustration assembly

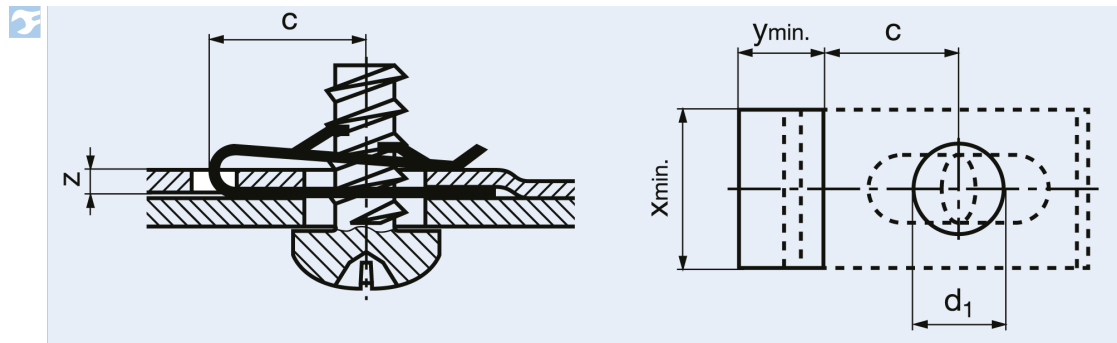

Warnings

ISO 4042
 Quenched and tempered fasteners ≥ 360 HV and tempered case-hardened fasteners with electroplated coatings:
 Susceptible to hydrogen embrittlement!
 Further notice to residual risks can be found in the introduction section.

| Article no | Code | α | b | for screws- \emptyset | c | e | s | z | d1 | x min | y min |
|------------|------|----------|------|-------------------------|------|------|-----|---------|-----|-------|-------|
| 5401149 | 4 | 11.2 | 7.9 | 2.9 | 4.8 | 5 | 0.5 | 0,7-1,2 | 4.8 | 8.3 | 5.5 |
| 5401150 | 6 | 16.5 | 11.2 | 3.5 | 6.7 | 7.9 | 0.6 | 0,7-1,6 | 6 | 11.4 | 6.1 |
| 5401151 | 8 | 16.5 | 11.2 | 4.2 | 6.7 | 7.9 | 0.6 | 0,7-1,6 | 7.2 | 11.4 | 7.6 |
| 5401152 | 10 | 19.8 | 12.7 | 4.8 | 7.9 | 9.6 | 0.7 | 0,9-2,1 | 8 | 12.9 | 9.4 |
| 5401153 | 12 | 26.2 | 15 | 5.5 | 11.1 | 12.4 | 0.8 | 0,9-2,6 | 10 | 15.4 | 9.9 |
| 5401154 | 14 | 25.1 | 15 | 6.3 | 12.7 | 10.5 | 0.8 | 0,7-1,9 | 8.7 | 15.5 | 14 |