

USR10 Sentry safety relay

Product description

USR10 is a safety relay that has multiple sensor monitoring functionality and timer functions. It is fully configurable and has preset selection possibilities and password protection. Error status codes are showed on the display.

Installation



WARNING: The product must be installed by a trained electrician following applicable safety regulations, standards and the machine directive.



CAUTION: The safety relay shall be attached on a 35 mm DIN rail in an enclosure that has at least protection class IP54.



CAUTION: Make sure there is at least 10 mm distance between the safety relay and other non-Sentry safety relay units to prevent uncontrolled heating.



CAUTION: Make sure there is at least 50 mm distance above and below the safety relay and other units for correct air flow in the venting holes of the safety relay.

Connection



WARNING: The safety relay and the sensor device for monitoring must be connected to SELV/PELV power supply.

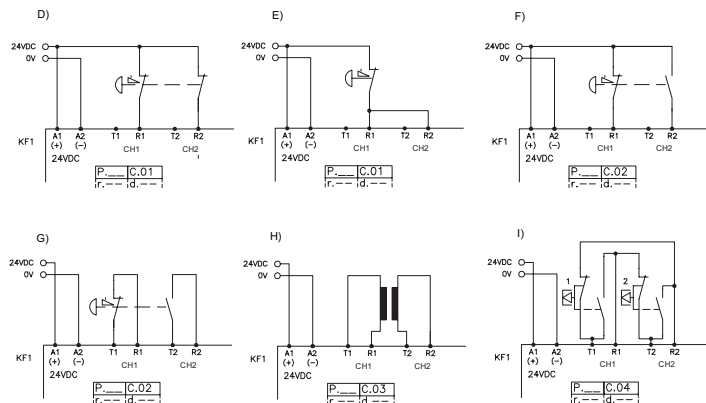
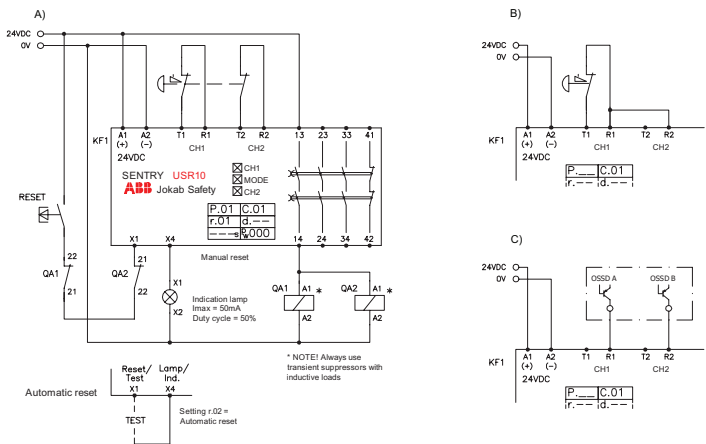

- [EN] The complete original instructions can be found at:
- [SE] Den kompletta bruksanvisningen i original finns på:
- [DE] Die komplette Originalbetriebsanleitung ist zu finden unter:
- [IT] Le istruzioni originali complete si trovano qui:
- [FR] La notice originale intégrale est disponible sur:
- [ES] La versión original de las instrucciones está disponible en:

www.abb.com/jokabsafety

- A. Two signals from T1/T2 (P.01, P.02)
- B. One signal from T1 (P.01, P.02)
- C. Two OSSD signals (P.01, P.02)
- D. Two signals from +24VDC (P.01, P.02)
- E. One signal from +24VDC (P.01, P.02)
- F. Antivalent signals from +24VDC (P.03, P.04)
- G. Antivalent signals from T1/T2 (P.03, P.04)
- H. Mat/Bumper/Safety edge (P.05, P.06)
- I. Two-hand device (P.07)

Configuration

Settings in Preset mode			
Preset	Configuration	Signal type	Reset
P.01	[C.01] Equivalent contacts	24 VDC/24 VDC	[r.01] Manual reset
P.02			[r.02] Automatic reset
P.03	[C.02] Antivalent contacts	Dynamic 1/ Dynamic2	[r.01] Manual reset
P.04			[r.02] Automatic reset
P.05	[C.03] Pressure sensitive device	Dynamic 1/ Dynamic2	[r.01] Manual reset
P.06			[r.02] Automatic reset
P.07	[C.04] Two-hand device		

LED indication

CH1/MODE/CH2	Comment	Action
off/off/off	The safety relay is not powered.	Check A1-A2 voltage connections.
green/green/green	CH1 and CH2 accepted. Reset done and outputs activated.	
off/blue/off	No channels closed	Check CH1 and CH2
green/blue/green	CH1 and CH2 closed, the safety relay wait for reset.	Check reset settings, wiring and reset circuit.
red/fast flash red/red	The safety relay is in failsafe mode.	Check error codes. Do a power cycling.

Technical data

Measurements	
Height/width/depth	120 mm/22.5 mm/120 mm
Power supply	
Power supply type	PELV/SELV
Operating voltage	+24 VDC +15 %, -20 %
Consumption	8 W
Fuse	4 A gG (4 A according to UL 248)
Relay output specification	
Maximum operating switching voltage	250 VAC
Overvoltage category	II
NO contact	



Extracts from the original instructions

USR10

Sentry safety relay

[EN] The complete original instructions can be found at:
 [SE] Den kompletta bruksanvisningen i original finns på:
 [DE] Die komplette Originalbetriebsanleitung ist zu finden unter:
 [IT] Le istruzioni originali complete si trovano qui:
 [FR] La notice originale intégrale est disponible sur:
 [ES] La versión original de las instrucciones está disponible en:

www.abb.com/jokabsafety

AC load (AC15, AC1), rated operational voltage, current 1/2/3 contact(s)	250 VAC, 5 A/ 5 A/ 4.6 A
DC load (DC13, DC1), rated operational voltage, current 1/2/3 contact(s)	+24 VDC, 6 A/5.6 A/4.6 A
Required fuse	6.3 A gG, 1 kA short circuit protection (6 A according to UL248)
NC contact	
AC load (AC15, AC1), rated operational voltage/current	250 VAC/0.5 A
DC load (DC13, DC1), rated operational voltage/current	+24 VDC/2 A
Required fuse	4A gG, 1 kA short circuit protection (4 A according to UL248)
Sensor interface specification	
Output T1 and T2	
Maximum output current (current limited internally to typical 70 mA)	50mA, nom 24 VDC
Input R1 and R2	
Maximum OSSD pulse length	1.0 ms
Input/output (I/O) X4	
Maximum output current (currently limited internally to typical 70 mA)	50 mA
Connection block and wire properties	
Maximum screw torque	0.8 Nm
Solid conductor, minimum	1 x 24 AWG (0.2 mm ²), 2 x 24 AWG (0.2 mm ²)
Solid conductor, maximum	1 x 12 AWG (3.31 mm ²), 2 x 16 AWG (1.31 mm ²)
Conductor with crimp sleeve, minimum	1 x 24 AWG (0.2 mm ²), 2 x 24 AWG (0.2 mm ²)
Conductor with crimp sleeve, maximum	1 x 12 AWG (3.31 mm ²), 2 x 16 AWG (1.31 mm ²)
Wire strip length	6-7 mm
Maximum response time	
Delay at power on	1.5 s
Response time at activation automatic reset/manual reset	50 ms/50ms
Response time at deactivation	20 ms
Electrical operations life time	
Load $\Sigma I_{th}^2 \leq 64$, AC1, AC15	160 000 operations
Load $\Sigma I_{th}^2 \leq 64$, DC1, DC13	100 000 operations
Mechanical operations lifetime	
10 ⁷ operations	
Environmental data	
Protection class, safety relay	IP20
Protection class, enclosure	At least IP54
Ambient temperature range for operation within specified operation range	-10°C – +65°C
Humidity range for operation	25 % ≤ Rh ≤ 90 %, non-condensing and without icing

Suitable for use at ≤ 2000 metres above sea level.	
Standard compliance and approvals	
Functional safety standard compliance	EN 61508-1:2010, up to SIL3 EN ISO 13849-1:2008, up to PLe/Cat.4 EN 62061:2005, up to SILCL3 EN 61511-1:2003
Approvals	CE, TÜV SÜD, cULus
Declaration of conformity	Can be found at: www.abb.com/jokabsafety
Information for use in USA/Canada	
Intended use	Applications according to NFPA 79
Power source	A suitable isolating source in conjunction with a fuse in accordance with UL 248
Fuse	The fuse shall be rated max. 4 A and be installed in the +24 VDC power supply to the device in order to limit the available current.

Maintenance



WARNING: The safety functions and mechanics shall be tested every year to confirm that the safety functions work properly.



WARNING: Repair and exchange of parts of the safety relay is not permitted since it may accidentally cause permanent damage to the product, impairing safety of the device which in turn could lead to serious injury to personnel. In case of breakdown or damage to the product contact ABB Jokab safety to replace the safety relay with a similar product.

While every effort has been taken to ensure the accuracy of information contained in this book and any associated promotional and information material ABB Jokab Safety cannot accept responsibility for errors or omissions and reserves the right to make any improvements without notice. It is the users responsibility to ensure that this equipment is correctly designed, specified, installed, cared for and operated to meet all applicable local, national and international codes/regulations. Technical data in our book is correct to the level of accuracy of ABB Jokab Safety's test procedures as verified by various international approved bodies. Other information (such as application examples, wiring diagrams, operation or use) is intended solely to illustrate the various uses of our products. ABB Jokab Safety does not guarantee or imply that the product when used in accordance with such examples in a particular environment will fulfil any particular safety requirement and does not assume any responsibility or liability for actual use of the product based on the examples given.