

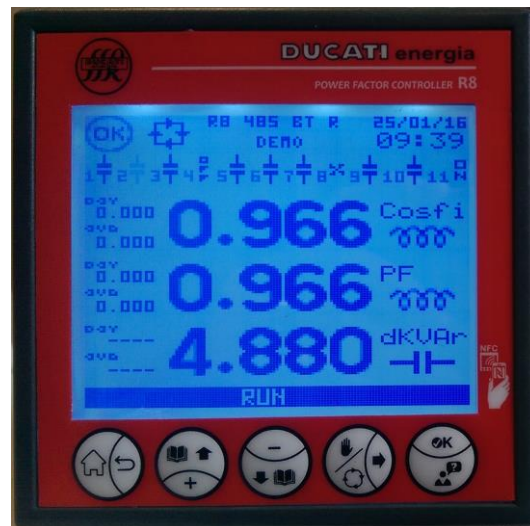

ASSEMBLY AND USE INSTRUCTIONS R8 POWER FACTOR CONTROLLERS



GENERAL DESCRIPTION

The automatic R8 power factor controllers are extremely adaptable to any application in the context of power factor correction systems for single-phase networks and low to medium voltage three-phase networks thanks to their compactness, the latest generation technology and the complete functionality range. The connectivity options make on-site data exchange and remote monitoring possible. The LCD with menu and user guide in 8 languages allows for an easy controller commissioning and use.

MAIN FEATURES

- 8-step power factor automatic controller (11 for "USB" and "BT" models).
- Graphic white LED 128x128 pixel backlit LCD, 5 navigation keys for functions and settings. User guide and menu messages available in 8 languages.
- Bluetooth, USB, 868MHz Radio, NFC, RS485 and connectivity options. Internal event log with data history up to 1 year and RTC sensor with bank.
- Voltage and current measurement accuracy: 1%±0.5 digit. Alarms can be completely defined by the user and associated to relay outputs.

Version C - November 2018

FW reference version: V 0.67 and higher





CONTENTS

1	R8 MODELS	5
2	WARNINGS	6
3	TECHNICAL FEATURES	7
4	INSTALLATION	9
5	CONNECTIONS	10
5.1	BASIC CONNECTIONS	10
5.1.1	Three-phase network without standard neutral with 400V phase-phase voltage.....	10
5.1.2	Three-phase network without neutral in cogeneration with 400V phase-phase voltage.....	12
5.1.3	Other Basic Connections.....	13
5.2	RS485 SERIAL CONNECTION	14
5.3	ALARM, SIGNALLING AND FAN OUTPUT CONNECTIONS	14
5.4	USB AND ETHERNET INTERFACE CONNECTION.....	15
6	HARDWARE CONFIGURATION AUTO-ACQUISITION AND COMMISSIONING	16
6.1	SYSTEM PARAMETER SETTING	16
6.2	COMPLETE AUTO-ACQUISITION.....	17
6.3	REDUCED AUTO-ACQUISITION.....	20
7	SETTINGS.....	23
7.1	CONNECTION SETTINGS.....	24
7.1.1	CT primary.....	24
7.1.2	CT secondary	24
7.1.3	CT phase	25
7.1.4	CT inversion.....	25
7.1.5	Cogeneration.....	25
7.1.6	Frequency.....	25
7.1.7	VT primary	25
7.1.8	VT secondary.....	26
7.1.9	Voltage phase.....	26
7.1.10	Phase offset	26
7.2	COSFI SETTINGS	27
7.2.1	Target cosfi	27
7.2.2	Cosfi tolerance	27
7.2.3	Cosfi time band 2	28
7.2.4	Cosfi time band 3	28
7.2.5	Cosfi TB4/GEN	28
7.2.6	Band B1.....	28
7.2.7	Band B2.....	29
7.2.8	Band B3.....	29
7.2.9	Band B4.....	29
7.2.10	Avg. integrat. time	29
7.3	POWER FACTOR CORRECTION SETTINGS.....	30
7.3.1	Step voltage	30
7.3.2	Manual mode.....	31
7.3.3	Connection time	31
7.3.4	Discharge time	31
7.3.5	Step disconnection.....	31
7.3.6	Relay output n (n=1÷11).....	32
7.3.6.1	Step n function (n=1÷11).....	33
7.3.6.2	Step Cn power (n=1÷11)	34
7.3.6.3	Alarm output n (n=1÷11).....	34
7.3.6.4	Manual status Cn (n=1÷11).....	35
7.4	COMMUNICATION INTERFACE SETTINGS	36
7.4.1	Protocol.....	36
7.4.2	Address.....	36
7.4.3	Baudrate.....	37
7.4.4	NFC information	37
7.4.5	USB	37
7.4.5.1	Update firmware.....	38



7.4.5.2	Update language	38
7.4.5.3	Import parameters.....	38
7.4.5.4	Export parameters.....	38
7.4.5.5	Export events.....	38
7.4.5.6	Export alarms	39
7.4.5.7	Export log meas.....	39
7.4.5.8	Export warnings	39
7.4.6	Ethernet.....	39
7.5	ALARMS AND FAN ACTIVATION SETTINGS.....	40
7.5.1	Overvoltage alarm threshold (HV Alarm Thres.).....	40
7.5.2	Overvoltage alarm delay (HV Alarm Delay).....	41
7.5.3	Overcurrent alarm threshold (HI Alarm Thres.).....	41
7.5.4	Overcurrent alarm delay (HI Alarm Delay).....	41
7.5.5	Low voltage alarm threshold (LV Alarm Thres.)	41
7.5.6	Low voltage alarm delay (LV Alarm Delay)	41
7.5.7	Low current alarm threshold (LI Alarm Thres.)	42
7.5.8	Low current alarm delay (LI Alarm Delay)	42
7.5.9	THDV% alarm threshold (THDV% Alarm Thres.)	42
7.5.10	THDV% alarm delay (THDV% Alarm Delay)	42
7.5.11	THDI% alarm threshold (THDI% Alarm Thres.)	42
7.5.12	THDI% alarm delay (THDI% Alarm Delay)	43
7.5.13	Overcompensation alarm delay (Hcosfi Alarm Delay)	43
7.5.14	Undercompensation alarm delay (Lcosfi Alarm Delay).....	43
7.5.15	Temperature alarm threshold (Temp. Alarm)	43
7.5.16	Temperature alarm delay (Temp. Alarm Delay)	44
7.5.17	Fan activation threshold (Fan A. Thres.).....	44
7.5.18	Fan activation delay (Fan A. Delay).....	44
7.6	SYSTEM SETTINGS.....	45
7.6.1	Language (Language setup).....	45
7.6.2	Temperature unit.....	45
7.6.3	Enable password.....	46
7.6.4	Password (Password setup)	46
7.6.5	Firmware rel.	46
7.6.6	Bootloader rel.	46
7.6.7	Language rel.	47
7.6.8	Backlight	47
7.6.9	Backlight auto	47
7.6.10	Contrast.....	47
7.6.11	Date.....	47
7.6.12	Time.....	48
7.6.13	Summertime.....	48
7.7	ADVANCED SETTINGS	49
7.7.1	Connection time differentiation (Connection time).....	49
7.7.2	Connection time in disconnection (Tdis).....	49
7.7.3	Evaluation time (Teval).....	50
7.7.4	Transient time during disconnection (Ttr dis).....	50
7.7.5	Transient time during insertion (Ttr ins).....	50
7.7.6	Measurement stability check (Sliding win.avg.).....	50
7.7.7	Measurement stability check threshold (%Slid. win. avg.).....	50
7.7.8	Inductor presence (Inductors).....	51
7.7.9	Degr. thres. 1	51
7.7.10	Breakage thr.1.....	51
7.7.11	Degr. thres. 2	51
7.7.12	Breakage thr.2.....	52
7.7.13	Current alarm reset (Alarm reset).....	52
7.7.14	Measurement display from harmonic Analysis (Harmonic analys.)	52
7.7.15	Auto-acquisition power threshold (Autodiagn.thres.)	52
7.7.16	868MHz address.....	53
7.7.17	868MHz channel	53
7.7.18	Network type	53
7.7.19	Voltage dip duration (Voltage dip)	53
7.7.20	Step connection maximum duration (Tmax step)	53
7.7.21	THDI invalidation threshold (Imax harmonic)	54
7.7.22	Alarm masking management (Alarm mask)	54



7.7.23	Log first meas.	54
7.7.24	Log second meas.	55
7.7.25	Log period	55
7.7.26	Enable log	55
7.8	PARAMETER RANGE AND DEFAUT VALUES	56
7.9	ENTERING MODES FOR PARAMETER VALUES	59
8	USING THE CONTROLLER	61
8.1	REGULATOR INFORMATIONS	61
8.1.1	Model and Serial Number	61
8.1.2	Firmware, Bootloader and Language release version	61
8.2	DISPLAY AND KEY DESCRIPTION	62
8.2.1	Display	62
8.2.2	Button function	64
8.3	MEASURES MENU	65
8.3.1	dkVAr measure	66
8.4	GRAPHICS MENU	67
8.5	EVENTS MENU	68
8.6	STATISTICS MENU	70
8.6.1	Working time	70
8.6.2	Contactors operations	70
8.6.3	Insertions	70
8.6.4	Real power	71
8.6.5	Step status	71
8.7	ALARMS AND FAN MANAGEMENT AND DISPLAY	72
8.7.1	Alarms state menu	72
8.7.2	Alarms and fan control description	74
8.7.2.1	Overvoltage alarm	74
8.7.2.2	Overcurrent alarm	74
8.7.2.3	Low voltage alarm	75
8.7.2.4	Low current alarm	76
8.7.2.5	THDI alarm	77
8.7.2.6	THDV alarm	77
8.7.2.7	Temperature alarm	78
8.7.2.8	Fan Control	79
8.7.2.9	Overcompensation alarm	80
8.7.2.10	Undercompensation alarm	80
8.7.2.11	Micro-interruption alarm	81
8.7.2.12	Step n breakage alarm (n=1,2,3,4,5)	82
8.8	RESET MENU	83
8.8.1	Factory settings	83
8.8.2	Alarm counters	83
8.8.3	Average values	83
8.8.4	Min / Max values	83
8.8.5	Step parameters	84
8.8.6	Contactors operations	84
8.8.7	PFC restart	84
8.8.8	Archives	85
8.9	COMMUNICATION INTERFACES	86
8.9.1	RS485 serial connection	86
8.9.2	868Mhz Radio	86
8.9.3	NFC	86
8.9.4	Bluetooth	87
8.9.5	USB	87
8.9.6	Ethernet	87
8.10	MANUAL POWER FACTOR CORRECTION MODE	88
8.11	PRESENCE OF BLOCKING REACTORS	89
8.12	FIRMWARE, BOOTLOADER AND LANGUAGE UPDATE	91



1 R8 MODELS

Power Factor Controller model	Part Numbers	Relay no.	485	ETH	Bluetooth	USB	868Mhz Radio	On Ducati Energia panel
R8	415986080NNNN	8						
R8 BT	415986080NBNN	11			✓			
R8 USB	415986080NSNN	11				✓		
R8 485	415986080QNNN	8	✓					
R8 485 BT	415986080QBNN	11	✓		✓			
R8 485 USB	415986080QSNN	11	✓			✓		
R8 ETH	415986080ENNN	8		✓				
R8 ETH BT	415986080EBNN	11		✓	✓			
R8 ETH USB	415986080ESNN	11		✓		✓		
R8 RADIO	415986080NNDN	8					✓	
R8 BT RADIO	415986080NBDN	11			✓		✓	
R8 USB RADIO	415986080NSDN	11				✓	✓	
R8 485 RADIO	415986080QNDN	8	✓				✓	
R8 485 BT RADIO	415986080QBDN	11	✓		✓		✓	
R8 485 USB RADIO	415986080QSDN	11	✓			✓	✓	
R8 ETH RADIO	415986080ENDN	8		✓			✓	
R8 ETH BT RADIO	415986080EBDN	11		✓	✓		✓	
R8 ETH USB RADIO	415986080ESDN	11		✓		✓	✓	
R8 INT	315986090NNNN	8						✓
R8 BT INT	315986090NBNN	11			✓			✓
R8 USB INT	315986090NSNN	11				✓		✓
R8 485 INT	315986090QNNN	8	✓					✓
R8 485 BT INT	315986090QBNN	11	✓		✓			✓
R8 485 USB INT	315986090QSNN	11	✓			✓		✓
R8 ETH INT	315986090ENNN	8		✓				✓
R8 ETH BT INT	315986090EBNN	11		✓	✓			✓
R8 ETH USB INT	315986090ESNN	11		✓		✓		✓
R8 RADIO INT	315986090NNDN	8					✓	✓
R8 BT RADIO INT	315986090NBDN	11			✓		✓	✓
R8 USB RADIO INT	315986090NSDN	11				✓	✓	✓
R8 485 RADIO INT	315986090QNDN	8	✓				✓	✓
R8 485 BT RAD INT	315986090QBDN	11	✓		✓		✓	✓
R8 485 USB RAD INT	315986090QSDN	11	✓			✓	✓	✓
R8 ETH RADIO INT	315986090ENDN	8		✓			✓	✓
R8 ETH BT RAD INT	315986090EBDN	11		✓	✓		✓	✓
R8 ETH USB RAD INT	315986090ESDN	11		✓		✓	✓	✓

Refer to [Chap. 3- TECHNICAL FEATURES](#) for details on the options listed in the table

GO BACK TO [CONTENTS](#)



2 WARNINGS

Carefully read this guide before using the power factor controller
The purpose of this guide is to provide the information to install and start using the models of the range of R8 power factor controllers.
The device must be installed and wired by qualified personnel.
An automatic switch or a disconnecter must be integrated with the electric system, duly positioned near the controller, and easily accessible by the operator. It must be marked as equipment disconnecting device: IEC/EN 61010-1 § 6.11.2
Risk of electrocution, burns and electric arc. Obtain the personal protective equipment appropriate to fulfil the current electrical safety standards.
Before making the connections, check the power supply disconnection with a voltage detection device that must be placed close to the power factor controller or, however, be easily accessed by the operator.
If necessary, clean the instrument using only a damp cloth.
The updated version of this manual and the complete operating manual are available on line at the following link https://www.ducatienergia.com/product.php?lang=en&id=8&cat=13&product=91

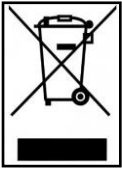

Do not dispose of the device as mixed municipal waste



The manufacturer, Ducati energia S.p.A. declares that R8 Controllers comply with the 2014/53/EU directive.

The complete text of the EU declaration of conformity is available at the following internet address:

<https://www.ducatienergia.com/product.php?lang=en&id=8&cat=13&product=91>



GO BACK TO [CONTENTS](#)



3 TECHNICAL FEATURES

- **Power supply:**
 - Nominal voltage: 400 or 230 or 110 VAC;
 - Operating limits: 110÷415 V AC/DC ±10%;
 - Frequency range: DC or 45÷66 Hz;
 - Power consumption: 2.5W
 - Max. power consumption: 10W (for “USB ETH” model)
 - Fuses: Fast 1A
- **Voltage input:**
 - Nominal voltage: 400 or 230 or 110 VAC;
 - Measuring range: 50÷525 VAC;
 - Accuracy: 1% ± 0.5 digit;
 - Frequency range: 45÷400 Hz;
 - Measuring type: true RMS (TRMS);
- **Current input:**
 - Input type: current shunt
 - Nominal current: 5A
 - Measuring range: 0.025÷6 A
 - Accuracy: 1% ± 0.5 digit
 - Measuring type: true RMS (TRMS)
 - Input consumption: <1.8VA
- **Relay outputs:**
 - Total number of outputs: 8 (11 for “USB” and “BT” models)
 - Contact type: 6 NO (common C1) + 1 NO (common C2) + 1 NO/NC (common C3)
 - Contact type for “USB” and “BT” models: 6 NO (common C1) + 1 NO (common C2) + 1 NO/NC (common C3) + 2 NO (common C4) + 1 NO (common C5)
 - Maximum operating voltage of NO contacts: 440 VAC
 - Maximum operating voltage of NO/NC contact: 400 VAC
 - NO contact nominal power: AC1 6A–250V~, AC15 1,5A-440V~
 - NO/NC contact nominal power: AC1 6A–250V~, AC15 1,5A-440V~
 - Mechanical/electrical duration of NO contacts: > 30x10⁶ / > 2x10⁵ operations
 - Mechanical/electrical duration of NO/NC contacts:> 1x10⁷ / > 1x10⁴ operations
- **User Interface:**
 - 5-key keyboard
 - Display: Graphic matrix white LED STN backlit 128x128px LCD
 - LCD visual area dimensions: 72.3x57mm
 - Backlight and contrast: adjustable levels from Setup menu
- **Environmental conditions:**
 - Operating temperature: -20÷70°C
 - Storage temperature: -30÷80°C
 - Overvoltage category: III
 - Measuring category: 3
 - Insulation voltage: 600V~
 - Relative humidity: < 80%
- **Connection terminals:**
 - Type: removable
 - Cable section: 0.2÷2.5 sq.mm (24÷12 AWG)
 - Tightening torque: 0.5 Nm
 - Stripping length: 7 mm
- **Enclosure:**
 - Size: 96x96 recessed
 - Material: PBT thermoplastic polyester
 - Protection degree: IP51 on the front side – IP20 on the terminals
 - Weight: 350g.
- **868MHz Radio interface**
 - Carrier frequency: 868MHz
 - Frequency range: 868.0 – 868.6 MHz
 - Maximum emitted power: 12.5mW
 - Protocol: Modbus
- **13.56MHz NFC interface**



- Data exchange with Smartphone through the antenna located behind the display – use Android app *Ducati Smart Energy*, which can be downloaded at the following link:
<https://play.google.com/store/apps/details?id=it.ducatienergia.smartenergy>
- **RS485 Interface**
 - Insulation voltage: 600V~
 - Protocols: Modbus-RTU, Ascii-Ducbus
 - Baud rate: 9600÷115200 bps
 - Termination resistance: 120Ohm – integrated (activated with jumper on connection terminal)
- **Ethernet Interface**
 - 10/100Base-T network board
 - Galvanically isolated RJ45 connector with auto-crossover MDI/MDX function
 - Insulation voltage: 600V~
 - Integrated web server
 - Modbus-TCP protocol
- **USB Interface**
 - USB-Host 2.0 type
- **Bluetooth Interface**
 - Bluetooth Low Energy (BLE) type
- **Compliance with standards**
EN 61010-1, EN 61000-6-2, EN 61000-6-4, EN 61326-1, EN 62311, EN 301-489-1, EN 301-489-3, EN 300-220-2, EN 300-330, EN 300-328-1

GO BACK TO [CONTENTS](#)

4 INSTALLATION

The controller must be installed on a vertical panel on which a square opening in compliance with IEC 61554 standard has been previously made. Opening dimensions must be 92.0mm x 92.0mm, with a permitted tolerance of +0.8mm and -0mm.

Insert **1** controller from panel front side and secure it **2** at the back with the 4 supplied retaining clips, letting them slide fully home against panel rear wall.

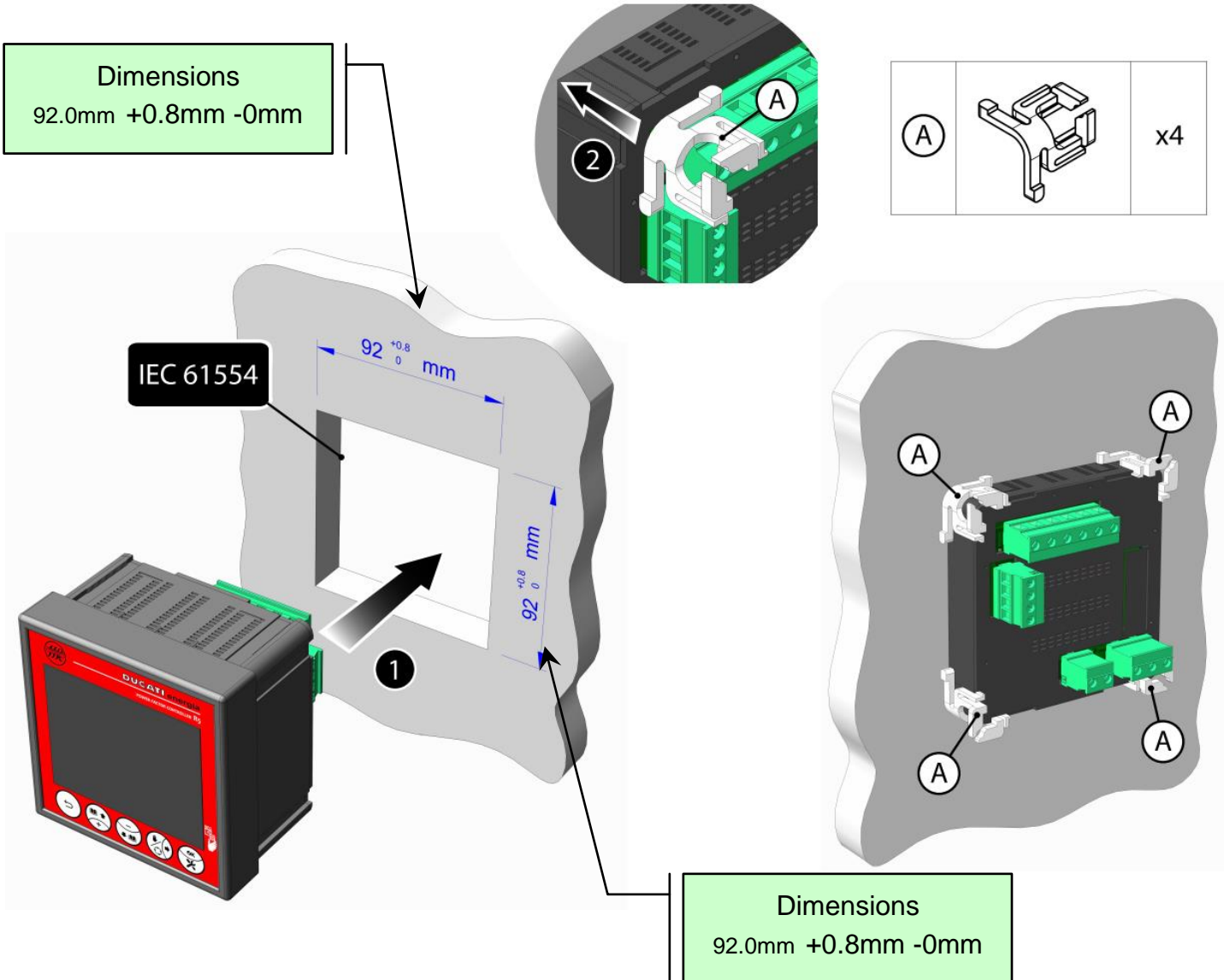

For flying connector wiring, refer to [Chap. 5- CONNECTIONS](#).

GO BACK TO [CONTENTS](#)

5 CONNECTIONS

For connections relating to supply and current inputs and relay outputs

GO TO [Chap. 5.1- Basic connections](#)

For the connections to the serial communication port

GO TO [Chap. 5.2 - RS485 serial connection](#)

For connections relating to output relays used as alarm, signalling and fan output contacts

GO TO [Chap. 5.3 - Alarm, signalling and fan output connection](#)

For the connections of the USB and Ethernet interfaces

GO TO [Chap. 5.4- USB and Ethernet interface connection](#)

GO BACK TO [CONTENTS](#)

5.1 Basic Connections

5.1.1 Three-phase network without standard neutral with 400V phase-phase voltage

In case of R8 controller with 8 relay outputs, connect it as shown in the figure below:

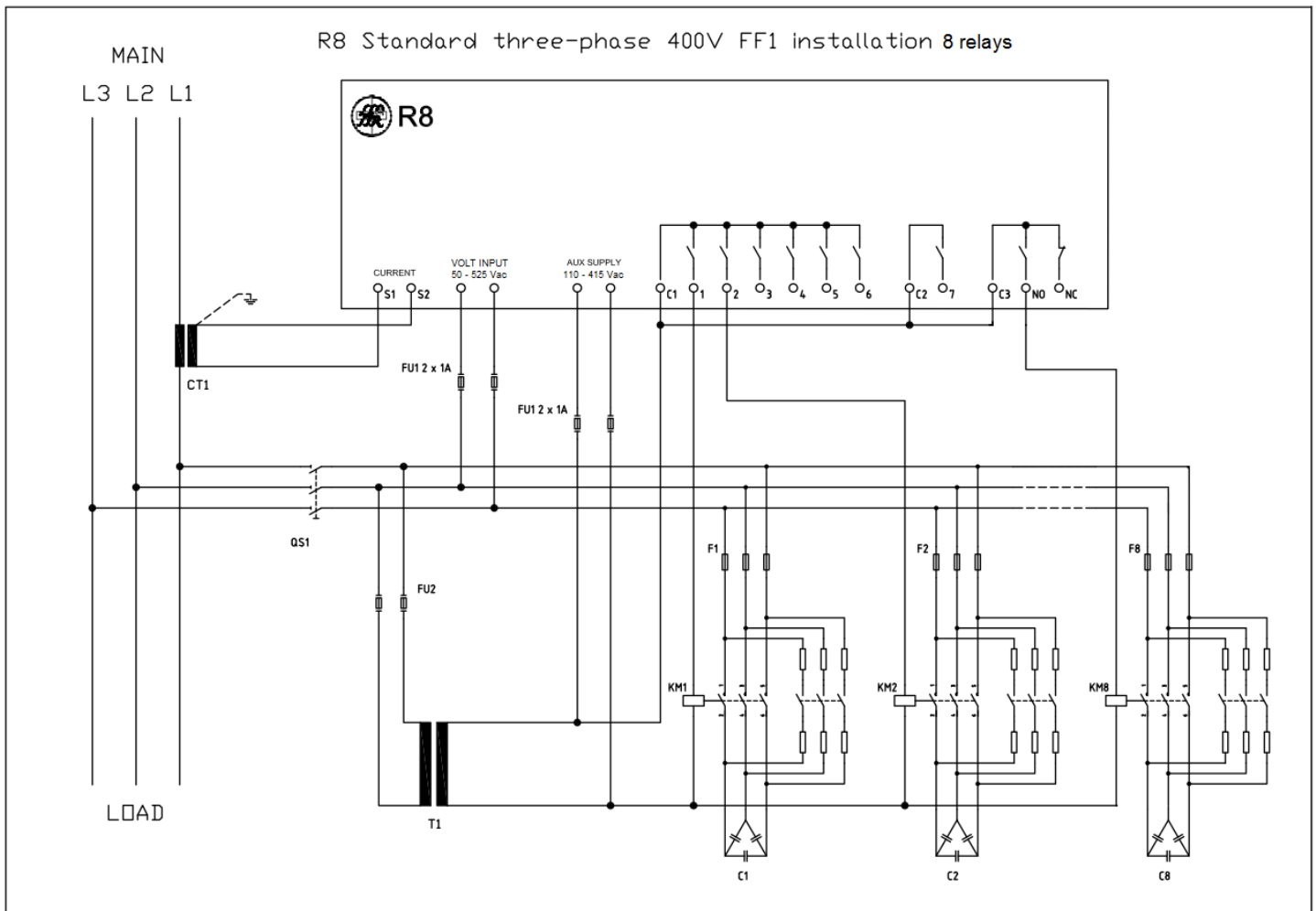

Instead, in case of R8 controller with 11 relay outputs, connect it as shown in the following figure:

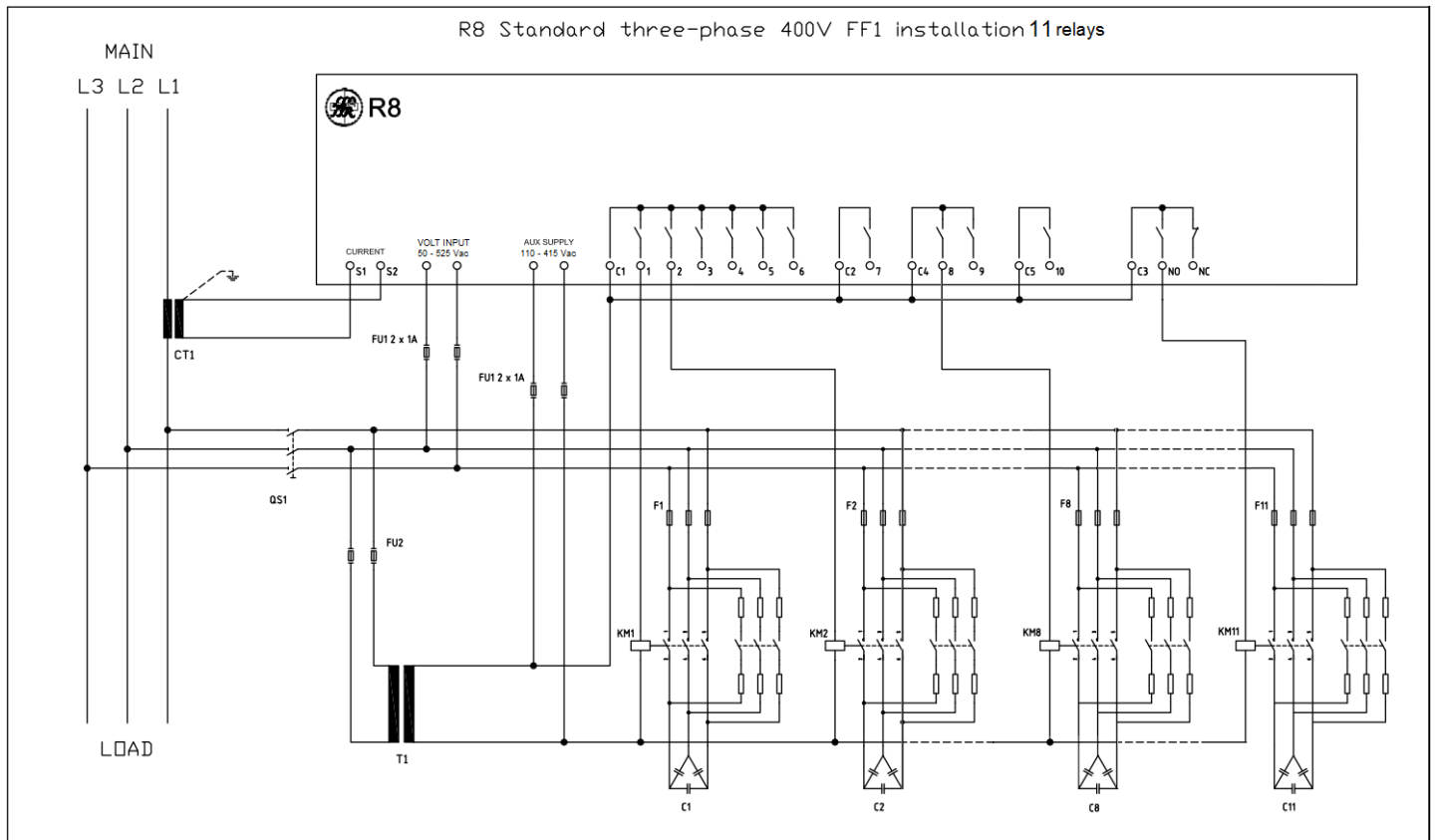

NOTE: the diagrams show an FF1 configuration, for configurations FF2 and FF3 just connect the current of phase L2 and L3 respectively instead of L1. For further information contact the technical support service at the following e-mail address: assistenza-rif@ducatienergia.com

Connect all the available power factor correction banks using terminals from 1 to 7 (10 for models with 11 outputs) and the NO/NC output as indicated for banks 1, 2 and 8 (11 for models with 11 outputs).

For the components indicated in the previous figures (CT1, F1..11, FU2, T1, KM1..11, C1..11 and QS1), refer to the power factor correction equipment manual and to the manual of the system on which the power factor controller is fitted.

CAUTION: At first power-up of the system, if on the amperometric input there is a current exceeding 0.7% of the **CT secondary** [Chap. 7.1.2](#) the auto-acquisition procedure will be automatically performed based on one of the methods specified in [Chap. 6](#). This procedure requires the essential parameters necessary for the first commissioning.

WARNING: If you want or if you need to edit the default parameters before auto-acquisition, do not connect the current signal to controller (CURRENT terminals), or make sure that the current reading is equal to zero.

Then set parameters through the [Setup Menu](#) consistently with the indications given in the table in [Chap.7.8](#).

NOTE 1: in case of blocking reactors, refer to the indications given in [Chap. 8.11- Presence of blocking reactors](#).

NOTE 2: the **Discharge time** ([Chap.7.3.4](#)) parameter must be set consistently with the indications given in the power factor correction equipment manual. WARNING: Entering a time shorter than the recommended one can lead to equipment and/or controller damage.

It is always possible to edit parameters even after the auto-acquisition and/or to repeat this latter using the functions of [PFC restart](#) ([Chap. 8.8.7](#)) and [Reset to factory settings](#) ([Chap. 8.8.1](#)).

GO BACK TO [CONNECTIONS](#)

GO BACK TO [CONTENTS](#)

5.1.2 Three-phase network without neutral in cogeneration with 400V phase-phase voltage

In case of R8 controller with 8 relay outputs, connect it as shown in the figure below:

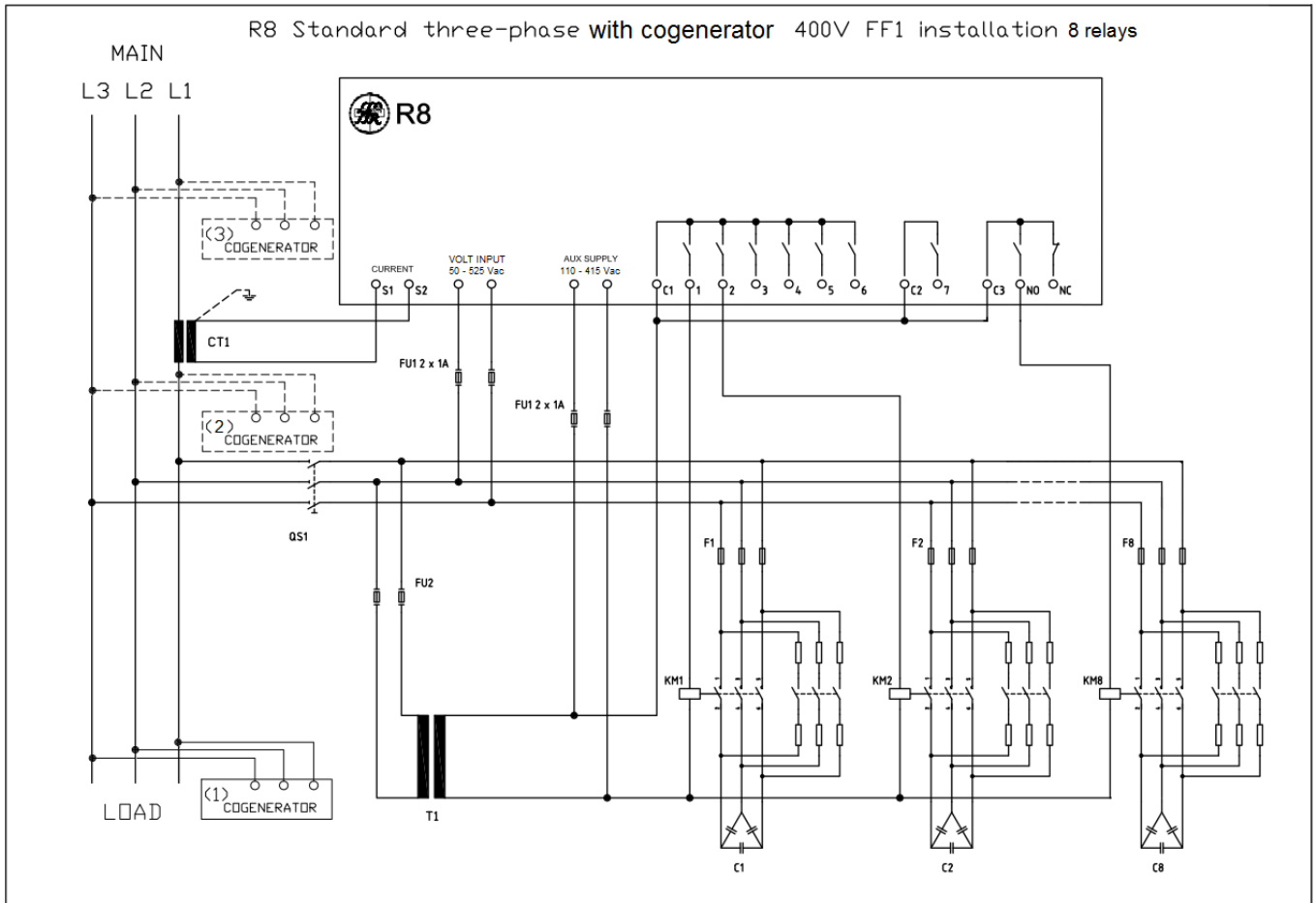

Instead, in case of R8 controller with 11 relay outputs, connect it as shown in the following figure:

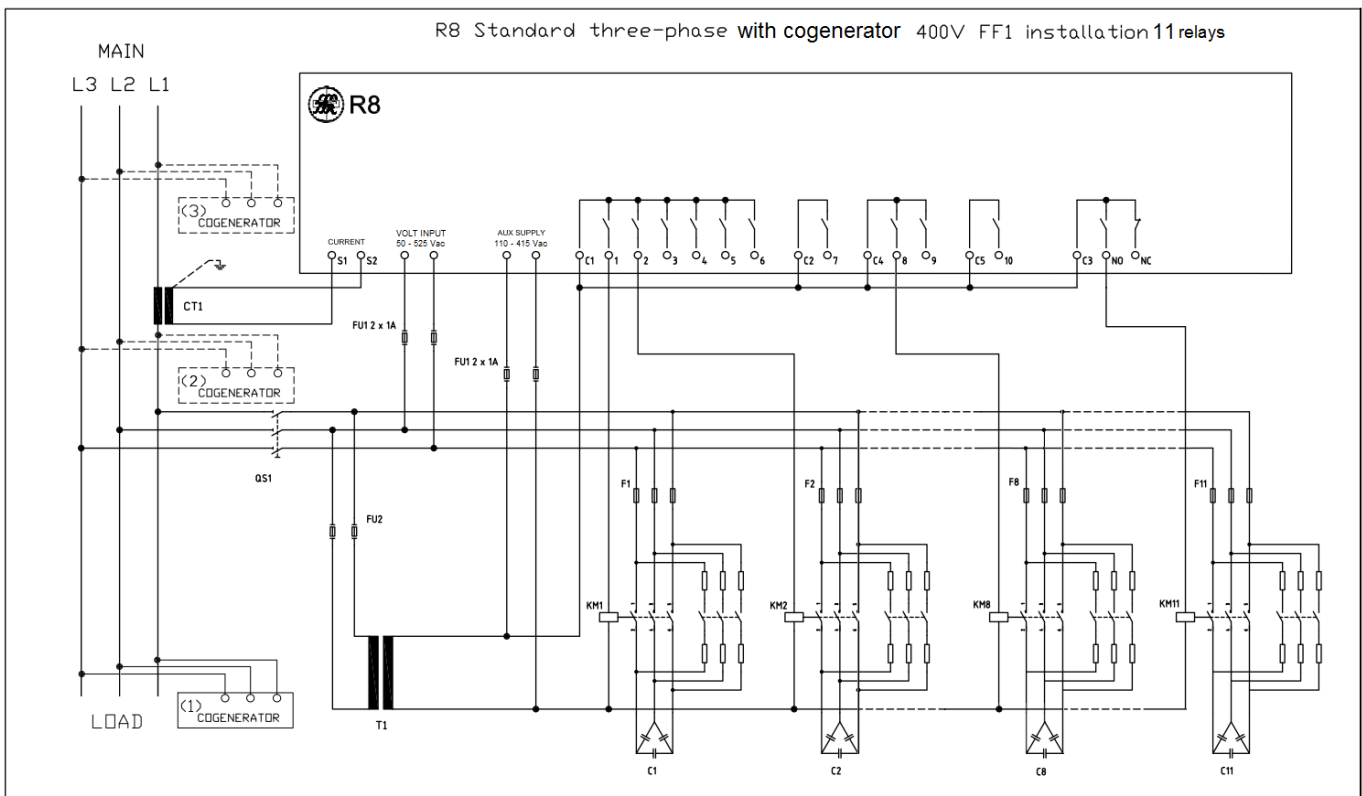



NOTE: the diagrams show an FF1 configuration, for configurations FF2 and FF3 just connect the current of phase L2 and L3 respectively instead of L1. For further information contact the technical support service at the following e-mail address: assistenza-rif@ducatienergia.com

Connect all the available power factor correction banks using terminals from 1 to 7 (10 for models with 11 outputs) and the NO/NC output as indicated for banks 1, 2 and 8 (11 for models with 11 outputs).

For the components indicated in the previous figures (CT1, F1..11, FU2, T1, KM1..11, C1..11 and QS1), refer to the power factor correction equipment manual and to the manual of the system on which the power factor controller is fitted.

As an alternative, the cogeneration system (COGENERATOR) can be connected in one of the three positions (1), (2) and (3) shown in the figures above. If the installation is made in points (1) or (2), the controller will also correct the power factor of the cogeneration system and the cogeneration operating mode will have to be enabled. If the installation is made in point (3), the controller will not correct the power factor of the cogeneration system, hence the relevant operation mode will not have to be enabled. For equipment installation, refer to the relevant manual.

CAUTION: At first power-up of the system, if on the amperometric input there is a current exceeding 0.7% of the **CT secondary** [Chap. 7.1.2](#) the auto-acquisition procedure will be automatically performed based on one of the methods specified in [Chap. 6](#). This procedure requires the essential parameters necessary for the first commissioning. If you wish to perform this procedure, **turn off the cogeneration systems**.

Once the auto-acquisition procedure is completed, turn on again the cogeneration systems and set the **Cogeneration** parameter to "ENABLED" if the cogeneration system is in (2) or (1). For further details, refer to [Chap. 7.1.5 - Cogeneration](#).

WARNING: If you want or if you need to edit the default parameters before auto-acquisition, do not connect the current signal to controller (CURRENT terminals), or make sure that the current reading is equal to zero.

Then set parameters through the [Setup Menu](#) consistently with the indications given in the table in [Chap.7.8](#).

NOTE 1: in case of blocking reactors, refer to the indications given in [Chap. 8.11- Presence of blocking reactors](#).

NOTE 2: the **Discharge time** parameter must be set consistently with the indications given in the power factor correction equipment manual. WARNING: Entering a time shorter than the recommended one can lead to equipment and/or controller damage.

It is always possible to edit parameters even after the auto-acquisition and/or to repeat this latter using the functions of [PFC restart \(Chap. 8.8.7\)](#) and [Reset to factory settings \(Chap. 8.8.1\)](#).

GO BACK TO [CONNECTIONS](#)

GO BACK TO [CONTENTS](#)

5.1.3 Other Basic Connections

Other connections can be made based on network configuration. For information and assistance contact Ducati Energia technical support service to the following E-mail address: assistenza-rif@ducatienergia.com.

GO BACK TO [CONNECTIONS](#)

GO BACK TO [CONTENTS](#)

5.2 RS485 serial connection

For the models featuring the RS485 serial port, connect the signal as indicated in the figure below, taking into account that the positive signal must be connected to pin A and the negative signal to pin B.

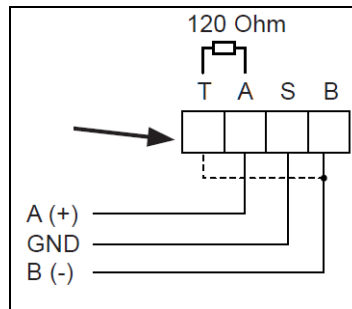

By short-circuiting pin B across pin T, the line can be terminated with a 120 Ohm resistance, already present inside the electronics.

For detailed information on protocol, address and baud rate parameter settings, refer to [Chap. 7.4 - Communication interface settings](#).

For detailed information on Modbus-RTU and ASCII Ducbus protocol specifications, refer to the documents available at the following web page [ftp://ftp.ducatienergia.com/DucatiSistemi/Protocols_Analysers/](http://ftp.ducatienergia.com/DucatiSistemi/Protocols_Analysers/)

5.3 Alarm, signalling and fan output connections

Relay outputs can be configured as alarm, signalling or fan outputs. For detailed information on how to configure an alarm, signalling or fan output refer to [Chap. 7.3 - Power factor correction settings](#).

NOTE: 7 outputs (relay 1 to 7) with single contacts and 1 output (relay 8) with double NO/NC contact will be available for models with 8 relay outputs. 10 outputs (relay 1 to 10) with single contacts and 1 output (relay 11) with double NO/NC contact will be available for models with 11 relay outputs.

The figure below shows how to connect output 1. Pay attention to which one is the reference common for each output.

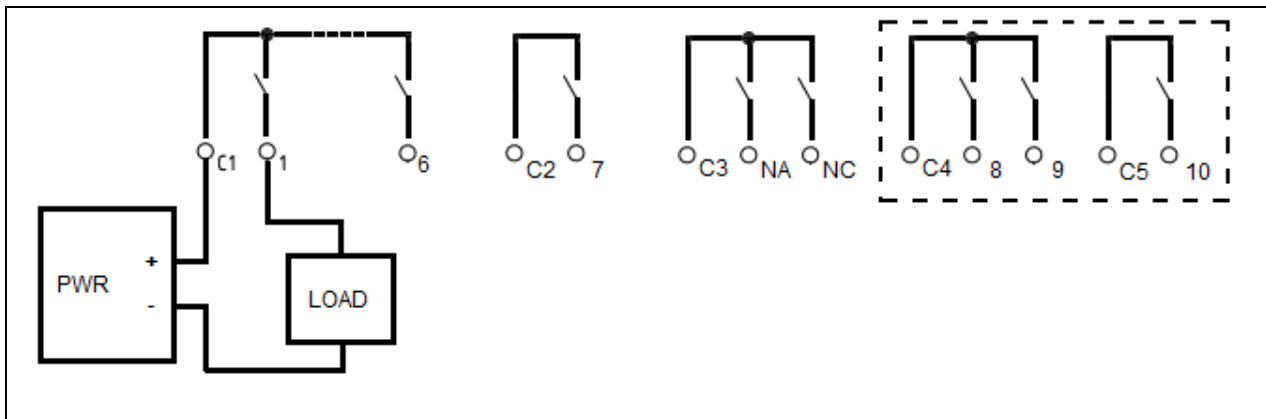

Models with 8 relay outputs	
Relay	Common
from 1 to 6	C1
7	C2
8 (NO/NC)	C3
Models with 11 relay outputs	
Relay	Common
from 1 to 6	C1
7	C2
8 and 9	C4
10	C5
11 (NO/NC)	C3

The power supply unit (PWR) and the reading electronics (LOAD) must comply with the indications provided in the technical features of relay outputs in [Chap. 3- TECHNICAL FEATURES](#).



The **alarm outputs** can be configured both in **NO logic** (normally open, as shown in the previous figure) and in **NC logic** (normally closed) and change their status consistently with the alarm activation status.

The **manual/automatic operation signalling outputs** will close in case of manual operation.

The output associated with the **signalling of R8 running (RUN)** can only be the one with NO/NC contacts (output 8 for models with 8 relays or output 11 for models with 11 relays) and is managed in **NO logic** (the NO contact is normally open and closes if the controller works regularly, while the NC contact is normally closed and opens if the controller is not working).

The outputs associated with the **fan output** are managed in NO logic and close in case of forced ventilation activation request. For further details, refer to **Chap. 7.5.17** and **Chap.7.5.18**.

The power supply unit (PWR) and the reading electronics (LOAD) must comply with the indications provided in the technical features of relay outputs in **Chap. 3- TECHNICAL FEATURES**.

5.4 USB and Ethernet interface connection

The USB interface, if present, is of the MSD Host 2.0 type with type A connector. It supports a FAT32 type system file. For all the informations about this interface refer to **Chap.7.4.5**.

To use the Ethernet interface, where present, connect the controller to the network through the RJ45 port. For all the informations and functions related to this interface refer to **Chap.7.4.6**.

GO BACK TO **CONNECTIONS**

GO BACK TO **CONTENTS**

6 HARDWARE CONFIGURATION AUTO-ACQUISITION AND COMMISSIONING

Some system settings (menu date, time and/or language) are requested at the first commissioning and upon power-up after particular events. For case description, and when this is requested, and for entering modes:

GO TO [Chap.6.1 - System parameter setting](#)

For the description and execution methods of a complete auto-acquisition (of phase, CT direction and powers of each bank):

GO TO [Chap. 6.2- Complete auto-acquisition](#)

For the description and execution method of a reduced auto-acquisition (of phase and CT direction):

GO TO [Chap. 6.3- Reduced auto-acquisition](#)

GO BACK TO [CONTENTS](#)

6.1 System parameter setting

On the R8 Controllers powered up for the first time, the setting screens of the following parameters will be shown in sequence:

- **Language:** (fig.1) The setting screen will be shown in English (default language) (for further details refer to [Chap.7.6.1](#));
- **Date:** (fig.2) The date "01/01/17" (default) will be shown (for further details refer to [Chap.7.6.11](#));
- **Time:** (fig.3) The time "00:00:00" (default) will be shown (for further details refer to [Chap.7.6.12](#)).
- **Summertime:** (fig.4) The "STANDARD TIME" configuration (default) will be shown (for further details refer to [Chap.7.6.13](#)).

If the backup battery is flat upon general power-up, only the screens relevant to the **Date** (fig.2), **Time** (fig. 3) and **Summertime** (fig. 4) will be shown in sequence.

If power-up is carried out following a procedure of **Reset to factory settings** ([Chap. 8.8.1](#)), only the **Language** setting screen (fig.1) will be shown.

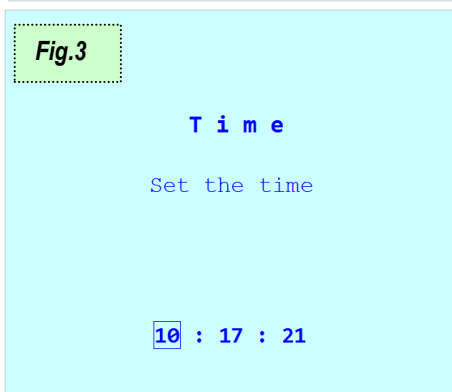
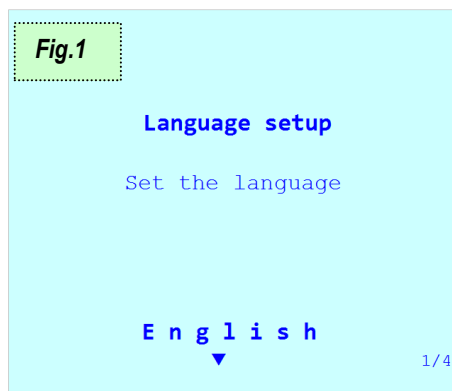

At the end, the controller will carry on with the **complete auto-acquisition** procedure.



6.2 Complete auto-acquisition

Here below is the **complete auto-acquisition** procedure applying to R8 controllers on which:

- o factory settings have not been modified (NOTE: R8 Controllers installed on Ducati Energia or third party equipment are not part of this category);
- o a **Reset to factory settings** procedure has just been carried out **Chap. 8.8.1**
- o all **Step Cn power (n=1÷11)** parameters are equal to zero and an **Auto-acquisition reset** procedure has just been performed **Chap. 8.8.7**



1.) ↘

At first system power-up or at power-up after a restart forced by the reset procedure, after the user has set/confirmed any system parameter requested according to the previous criteria **Chap.6.1**, the R8 Controller performs an automatic insertion of capacitor banks to check the connections and the amount of bank power.

In order to properly perform these initial checks, you must:

- o **turn off** any generation plants (if present);
- o make sure the system load is **stable** and that the current measured by the controller is not a **non-zero** current and 0.7% higher than the **CT secondary** parameter **Chap. 7.1.2**.

2.) ↘

Before checking the connections, the controller will show the setting screens of the values of

- o **CT primary** (fig.5) (to enter the numerical value, refer to **Chap.7.1.1**);
- o **CT secondary** (fig.6) (to enter the numerical value, refer to **Chap. 7.1.2**);
- o **Step voltage** (fig.7) (to enter the numerical value, refer to **Chap.7.3.1**).

With no input current, the Controller will not show these screens and:

- o it will go back to the home page;
- o the controller will also indicate the signals relating to the **low current alarm** **Chap.8.7.2.4**.

Under these circumstances:

- o it is anyway possible to access the **Setup Menu** **Chap. 7- SETTINGS** in order to pre-set the operating parameters. If in this phase even just one of the **Step Cn power (n=1÷11)** parameters is modified, when the Controller will measure a stable non-zero current, a **Reduced auto-acquisition** procedure will be performed **Chap.6.3**;
- o it is anyway possible to move to the **Manual power factor correction mode** **Chap. 8.10** to manually insert the banks;

When the controller will measure a stable non-zero current, it will show the setting pages of **CT primary**, **CT secondary** (fig. 5 and 6) and **Step voltage** (fig. 7).

<p>Fig.5</p> <p>CT primary</p> <p>Enter CT primary Example: for 100/5 enter 100</p> <p>00005</p>	<p>Fig.6</p> <p>CT secondary</p> <p>Enter CT secondary Example: for 100/5 enter 5</p> <p>5</p>	<p>Fig.7</p> <p>S t e p v o l t a g e</p> <p>Set the capacitors' nominal voltage</p> <p>415 v</p>
---	---	--



	Return to the screen of the previous parameter / Cancel current change
	Increase the value of the selected digit
	Decrease the value of the selected digit
	Select next digit during parameter change
	Confirm value and pass to the screen of the next parameter

3.)

After setting the values of **CT primary**, **CT secondary** and **Step voltage**, the controller will check the voltage/current connections by cyclically inserting the capacitor banks (figures from 8 to 12 showing the procedure for a model with 8 relays). After each insertion, the controller will show the calculated configuration for a few seconds (refer to **Chap.5.1**). A minimum of 2 to a maximum of 5 cycles of insertion cycles are needed, at the end of which the controller will automatically set the type of detected connection. The duration of a cycle is equal to the greatest value between one minute and the value of the **Discharge time** parameter **Chap.7.3.4**.

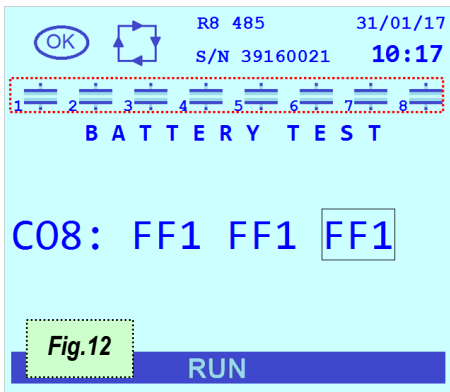
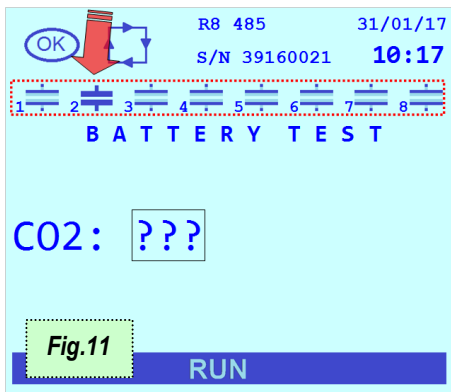
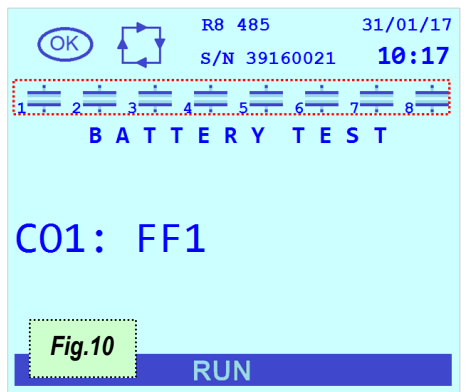
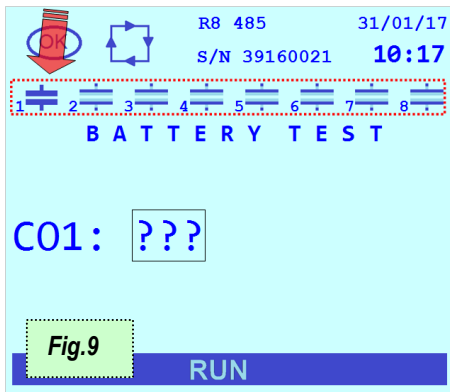
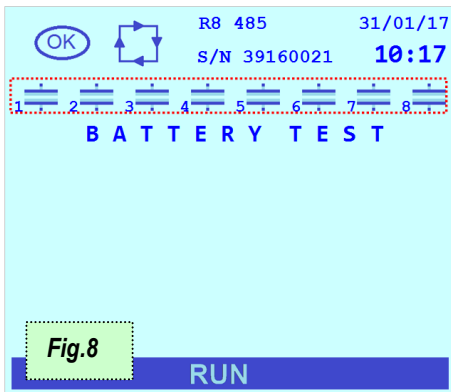

In case of the controller is not able to automatically define the type of configuration due to unfavourable load conditions, it will show an error screen and then the setting screen of parameter **CT phase** **Chap. 7.1.3** that will have to be manually entered (or confirmed) (fig. 13).

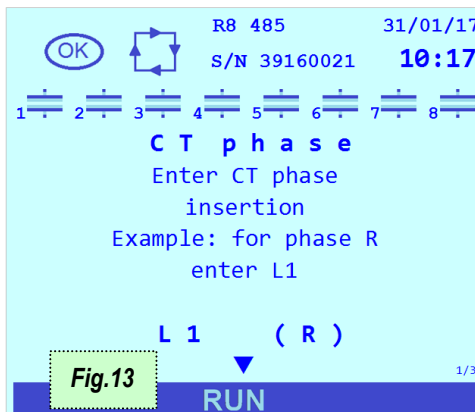



	Return to the screen of the previous parameter / Cancel current change
	Change current phase connected to controller
	Change current phase connected to controller
	Go to the next parameter screen
	Confirm current phase and go to the screen of the next parameter

4.) ↘

After checking the connection, the controller will show the screens of reactive power estimated values for each bank (parameter **Step Cn power (n=1÷11)**): it is possible to confirm or modify the values to finish the start-up procedure (figures 14 and 15).

Note: for the banks with unstable power measurement (generally due to a load that varies quickly during the procedure) the 0 kVar value will be suggested.

WARNING: an unstable load during self-acquisition alters the calculated value considerably. If the values differ from those specified in the documents (or on the plate) of the power factor correction equipment, edit them by entering the reactive power values at bank nominal voltage.

Note: In case of blocking reactors, refer to **Chap. 8.11 - Presence of blocking reactors**.

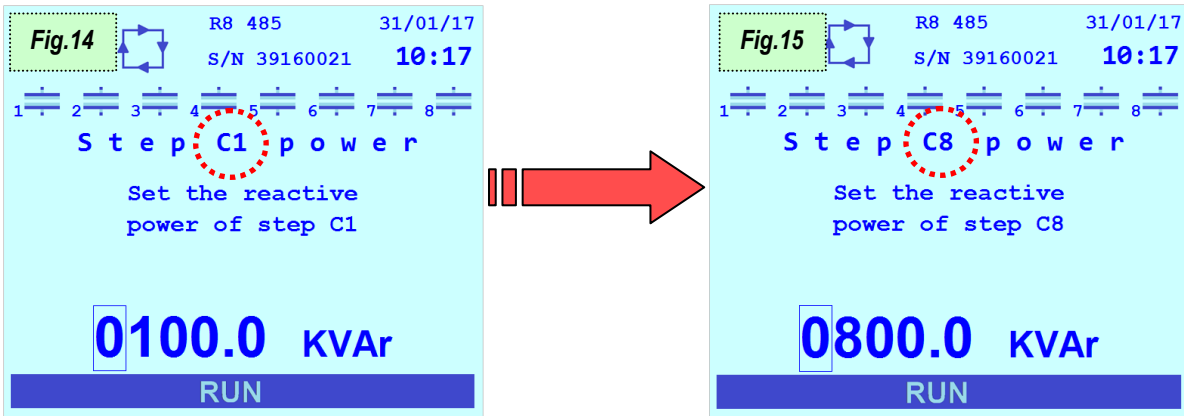

	Return to the screen of the previous parameter / Cancel current change
	Increase the value of the selected digit
	Decrease the value of the selected digit
	Select next digit during parameter change
	Confirm value and pass to the screen of the next parameter

5.) ↘

At the end, the controller will go back to the home page.

Any generation plants present can be turned on; in this case set the **Cogeneration** parameter = "ENABLED" from the Setup Menu **Chap. 7- SETTINGS**.

GO BACK TO **HARDWARE CONFIGURATION AUTO-ACQUISITION AND COMMISSIONING**

GO BACK TO **CONTENTS**



6.3 Reduced auto-acquisition

Here below is the **reduced auto-acquisition** procedure applying to R8 Controllers:

- whose factory settings have been modified according to the procedure described in **Chap. 5 - CONNECTIONS** and on which no previous auto-acquisition has been performed;
- that are installed on Ducati Energia equipment and are powered on for the first time;
- have at least one of the **Step Cn power (n=1÷11)** parameters not equal to zero and on which an **Auto-acquisition reset** procedure has just been performed **Chap. 8.8.7**.



1.) ⚡

At first system power-up or at power-up after a restart forced by the reset procedure, after the user has set/confirmed any system parameter requested according to the previous criteria **Chap.6.1**, the R8 Controller performs an automatic insertion of capacitor banks to check the connections and the amount of bank power.

In order to properly perform these initial checks, you must:

- **turn off** any generation plants (if present);
- make sure the system load is **stable** and that the current measured by the controller is not a **non-zero** current and 0.7% higher than the **CT secondary** parameter **Chap. 7.1.2**.

2.) ⚡

Before checking the connections, the controller will show the setting screens of the values of

- **CT primary** (fig.5) (to enter the numerical value, refer to **Chap. 7.1.1**);
- **CT secondary** (fig.6) (to enter the numerical value, refer to **Chap. 7.1.2**);

With no input current, the Controller will not show these screens and:

- it will go back to the home page;
- the controller will also indicate the signals relating to the **low current alarm** **Chap.8.7.2.4**.

Under these circumstances:

- it is anyway possible to access the **Setup Menu** **Chap. 7 - SETTINGS** in order to pre-set the operating parameters.
- it is anyway possible to move to the **Manual power factor correction mode** **Chap. 8.10** to manually insert the banks;

When the controller will measure a stable non-zero current, it will show the setting pages relating to **CT primary** and **CT secondary** (fig. 5 and 6).

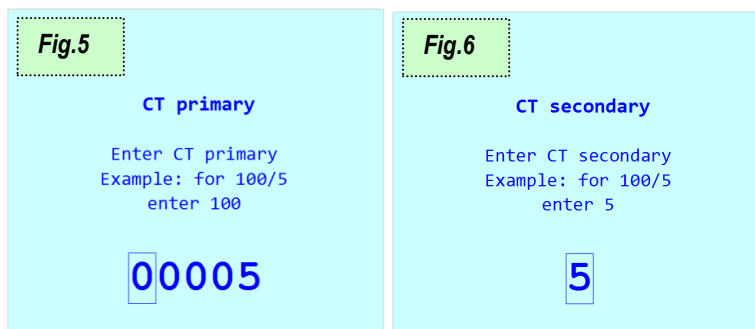

	Return to the screen of the previous parameter / Cancel current change
	Increase the value of the selected digit
	Decrease the value of the selected digit
	Select next digit during parameter change
	Confirm value and pass to the screen of the next parameter



3.) ↘

After setting the values of **CT primary** and **CT secondary**, the controller will check the voltage/current connections by cyclically inserting the capacitor banks (figures from 8 to 12 showing the procedure for a model with 8 relays). After each insertion, the controller will show the calculated configuration for a few seconds (refer to **Chap.5.1**). A minimum of 2 to a maximum of 5 cycles of insertion cycles are needed, at the end of which the controller will automatically set the type of detected connection. The duration of a cycle is equal to the greatest value between one minute and the value of the **Discharge time** parameter **Chap.7.3.4**.

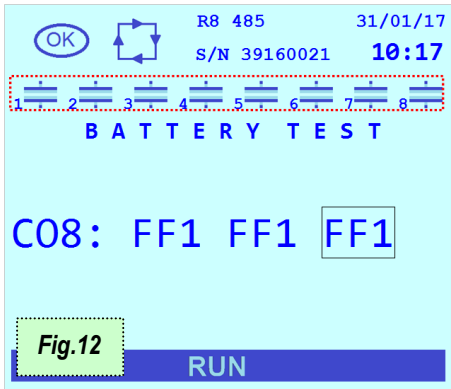
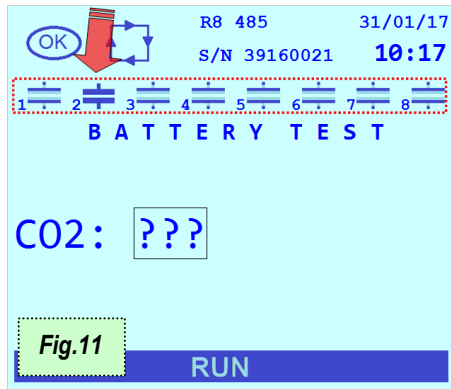
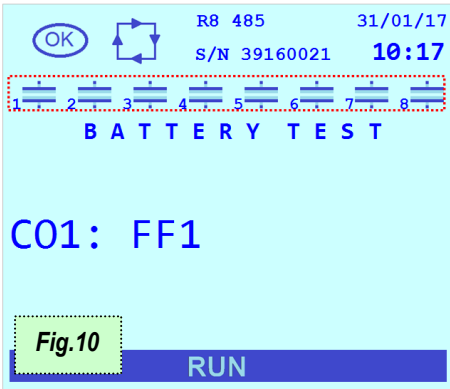
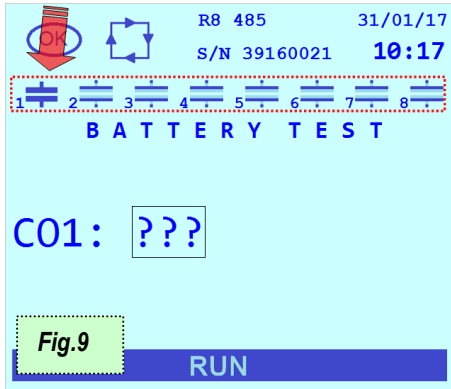
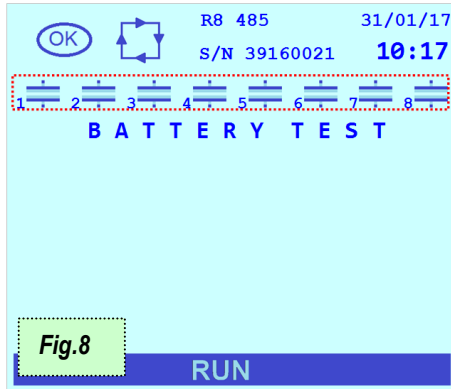

Should the controller not be able to automatically define the type of configuration due to unfavourable load conditions, it will show an error screen and then the setting screen of parameter **CT phase** **Chap. 7.1.3** that will have to be manually entered (or confirmed) (fig. 13).

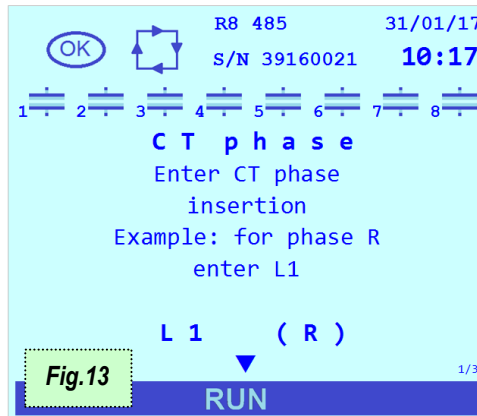

	Return to the screen of the previous parameter / Cancel current change
	Change current phase connected to controller
	Change current phase connected to controller
	Go to the next parameter screen
	Confirm current phase and go to the screen of the next parameter



4.) 

Afterwards, the controller will go back to the home page.

Any generation plants present can be turned on; in this case set the **Cogeneration** parameter = "ENABLED" from the Setup Menu [Chap. 7- SETTINGS](#).

GO BACK TO [HARDWARE CONFIGURATION AUTO-ACQUISITION AND COMMISSIONING](#)

GO BACK TO [CONTENTS](#)

7 SETTINGS

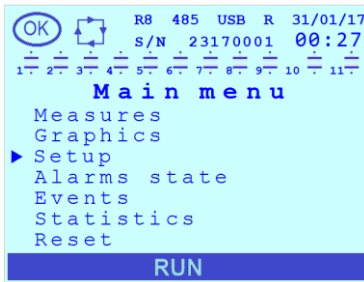

In the Main Menu page, through keys  or , move the cursor on “**Setup**” and

press key .

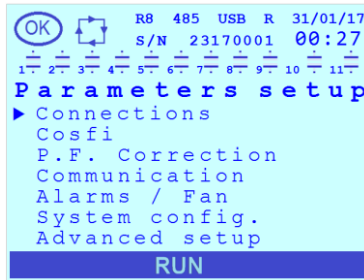

The Setup Menu contains the following items: **Connections**, **Cosfi**, **P.F. Correction**, **Communication**, **Alarms / Fan**, **System config.** and **Advanced setup**.

Each menu item contains other sub-menus. For further details, refer to the relevant chapters.

GO TO [Chap. 7.1 - Connection settings](#)

GO TO [Chap. 7.2 - Cosfi settings](#)

GO TO [Chap. 7.3 - Power factor correction settings](#)

GO TO [Chap. 7.4 - Communication interface settings](#)

GO TO [Chap. 7.5 – Alarms and fan activation settings](#)

GO TO [Chap. 7.6 - System settings](#)

GO TO [Chap. 7.7 - Advanced settings](#)

GO TO [Chap. 7.8 - Parameter range and default values](#)

GO TO [Chap. 7.9 - Entering modes for parameter values](#)

GO BACK TO [CONTENTS](#)



7.1 Connection settings

In this section it is possible to:

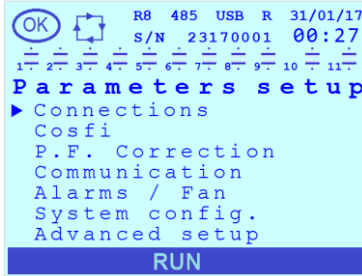

- define the parameters of any CT and VT present at the amperometric and voltmetric inputs, respectively;
- set the phases used to read current and voltage;
- enable the cogeneration operating mode and the CT direction inversion mode;
- set the network frequency and the frequency of any phase offset present on the voltage signal.

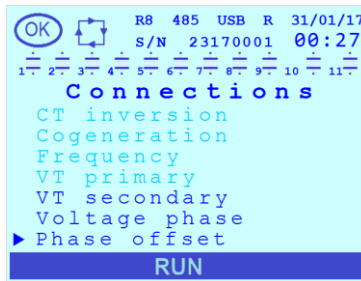
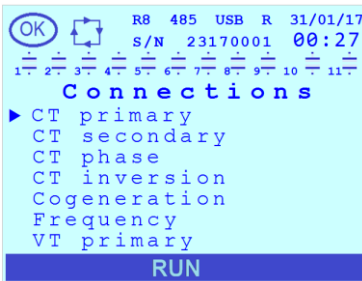

In the "Setup" Menu, through keys  or , move the cursor on "**Connections**" and press key .



The "**Connections**" menu contains the following items: **CT primary**, **CT secondary**, **CT phase**, **CT inversion**, **Cogeneration**, **Frequency**, **VT primary**, **VT secondary**, **Voltage phase** and **Phase offset**.

Through the keys  or , move the cursor on the relevant item and press key  to view it and/or change it.

To exit the page relevant to a parameter and/or go back to the previous menu press key .

Refer to **Chap. 7.9** for the indications on the setting modes of the parameter values.

7.1.1 CT primary

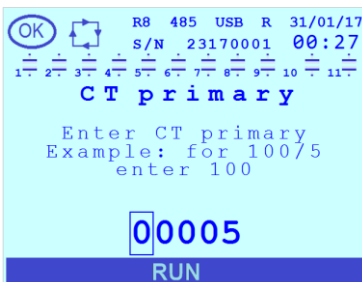

This parameter defines the full scale value of the primary winding current of the Amperometric Transformer (CT). The default value is "5". The permitted range for the parameter is [5÷10000]A.

7.1.2 CT secondary

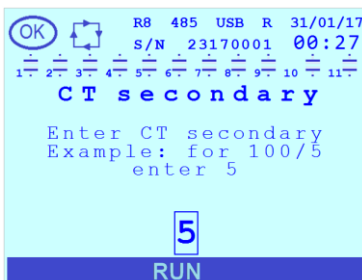

This parameter defines the full scale value of the secondary winding current of the Amperometric Transformer (CT). The default value is "5". The permitted range for the parameter is [1÷5]A.

7.1.3 CT phase

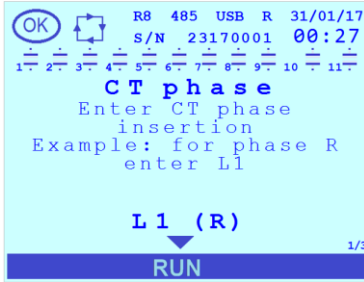

The default value is "L1 (R)". The permitted values for the parameter are [L1 (R); L2 (S); L3 (T)].

If the CT was connected to the R phase select "L1 (R)"; if the CT was connected to the S phase select "L2 (S)"; if the CT was connected to the T phase select "L3 (T)".

7.1.4 CT inversion

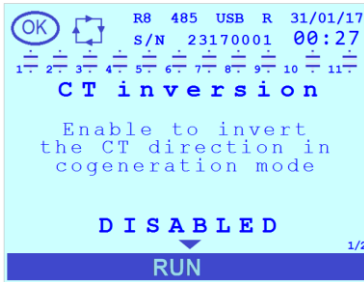

The default value is "DISABLED". The permitted values for the parameter are [DISABLED; ENABLED].

If the cogeneration mode is enabled (**Cogeneration** = ENABLED), by setting this parameter to "ENABLED" the CT direction can be reversed via software without acting on the connections.

7.1.5 Cogeneration

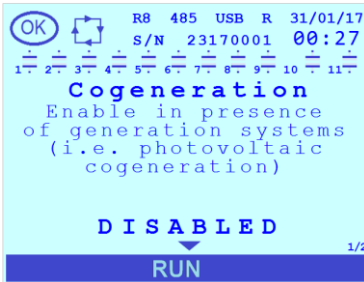

The default value is "DISABLED". The permitted values for the parameter are [DISABLED; ENABLED].

Set parameter to "ENABLED" when the CT is mounted on a line on which the current is generated by cogeneration systems and is absorbed by the load. If this parameter is set to "DISABLED" the CT direction will be automatically corrected via software to achieve always positive active power values.

7.1.6 Frequency

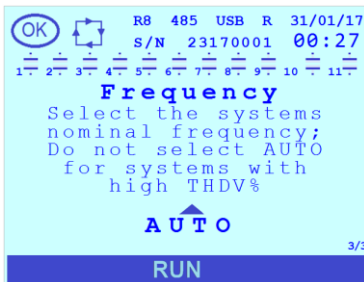

The default value is "AUTO". The permitted values for the parameter are [AUTO; 50Hz; 60Hz].

Set the "AUTO" value to enable the automatic selection between 50 and 60Hz upon controller first powering-up. In case of an excessive voltage harmonic distortion (measurement THDV%), we recommend setting the value at 50 Hz or 60 Hz, based on system nominal frequency.

7.1.7 VT primary

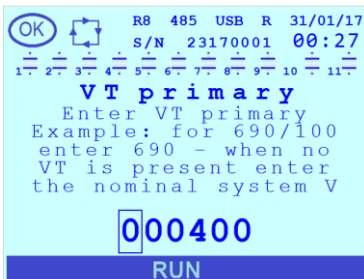

This parameter defines the full scale value of the primary winding voltage of the Voltmetric Transformer (VT). The default value is "400". The permitted range for the parameter is [50÷200000]V.

NOTE: If the VT is not present, set the connected network voltage value (400 or 230).



7.1.8 VT secondary

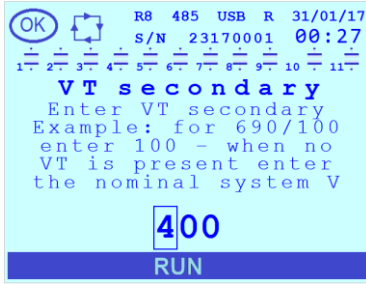

This parameter defines the full scale value of the secondary winding voltage of the Voltmetric Transformer (VT). The default value is "400". The permitted range for the parameter is [50÷525]V.

NOTE: If the VT is not present, set the connected network voltage value (400 or 230).

7.1.9 Voltage phase

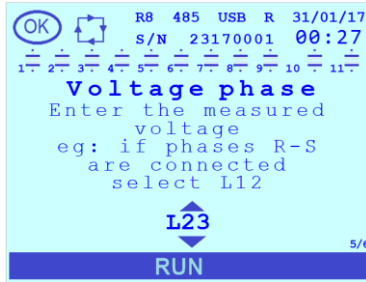

The default value is "L23". The permitted values for the parameter are [L1n; L2n; L3n; L12; L23; L31].

Example 1: if the measurement input (or the VT) was connected between the phases S and T, select the value "L23".

Example 2: if the measurement input (or VT) was connected between the R phase and the neutral, select the value "L1n".

7.1.10 Phase offset

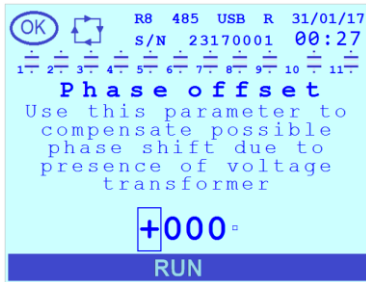

The default value is "0". The permitted range for the parameter is [-180÷180]°.

Set the value of the additional phase shift (in degrees) added to the voltage signal (for example by the presence, if any, of a medium-voltage voltmetric transformer).

GO BACK TO [SETTINGS](#)



GO BACK TO [CONTENTS](#)

7.2 Cosfi settings

In this section it is possible to:

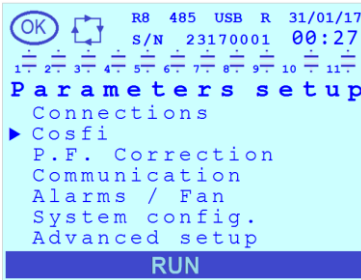

- define the cosfi value range within which the controller will consider the system corrected;
- set the target cosfi by dividing the day up to a maximum of 4 time bands;
- set the target cosfi if the system to which the power factor correction system is connected is in generation mode;
- define the average time on which the measurement average value is calculated.

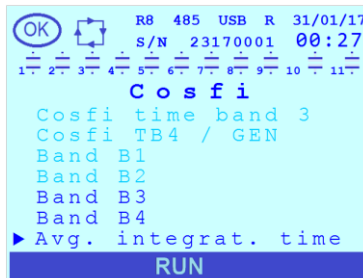
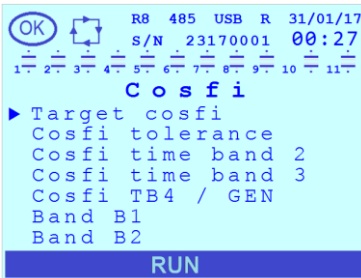

In the "Setup" Menu, through keys  or , move the cursor on "**Cosfi**" and press key .



The "**Cosfi**" menu contains the following items: **Target cosfi**, **Cosfi tolerance**, **Cosfi time band 2**, **Cosfi time band 3**, **Cosfi TB4/GEN**, **Band B1**, **Band B2**, **Band B3**, **Band B4** and **Avg. integrat. time**.

Through the keys  or , move the cursor on the relevant item and press key  to view and/or change it.

To exit the page relevant to a parameter and/or go back to the previous menu press key .

Refer to **Chap. 7.9** for the indications on the setting modes of the parameter values.

7.2.1 Target cosfi



This parameter defines the target cosfi value in **Band B1**. The default value is "0,980", inductive. The permitted range for the numerical value is [0,500÷1,000]. It is also possible to set a load, both inductive and capacitive, by changing the symbol on the left of the numerical value.

NOTE: This parameter and the **Cosfi tolerance** parameter define together the value range within which the controller will consider system as corrected in **Band B1** and, consequently, also the activation thresholds for undercompensation and overcompensation alarms. For further details, refer to **Chap. 7.2.2**.

7.2.2 Cosfi tolerance

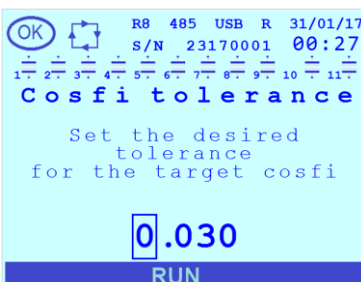

The default value is "0.03". The permitted range for the parameter is [0,010÷0,100].

For each time band, together with **Target cosfi**, **Cosfi time band 2**, **Cosfi time band 3** and **Cosfi TB4/GEN** respectively, this parameter defines the value range within which the controller will consider the system corrected.

EXAMPLE: with **Target cosfi** = 0.970 inductive and **Cosfi tolerance** = 0.020, the **Band B1** will try to reach a cosfi value between 0.950 inductive and 0.990 inductive. In these conditions: with a cosfi value < 0.950 the controller will insert

a capacitor bank (or it will display an undercompensation error after the time set by parameter **Lcosfi Alarm Delay** (Chap. 7.5.14) of permanence of the value outside the tolerance range) with a cosfi value > 0.991 or a capacitive cosfi value, the controller will deactivate the capacitor bank (or it will display an overcompensation error after the time set by parameter **Hcosfi Alarm Delay** (Chap.7.5.13) of permanence of the value outside the tolerance range).

7.2.3 Cosfi time band 2

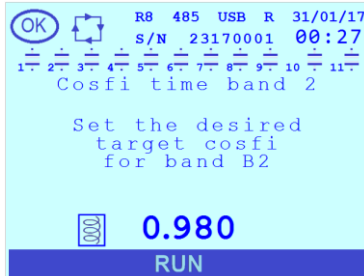

This parameter defines the target cosfi value in **Band B2**. The default value is "0,980", inductive. The permitted range for the numerical value is [0,500÷1,000]. It is also possible to set a load, both inductive and capacitive, by changing the symbol on the left of the numerical value.

NOTE 1: This parameter and the **Cosfi tolerance** parameter define together the value range within which the controller will consider the system as corrected in **Band B2** and, consequently, also the activation thresholds for the undercompensation and overcompensation alarms.

NOTE 2: this parameter is significant only if a **Band B2** (Chap.7.2.7) has been set.

7.2.4 Cosfi time band 3

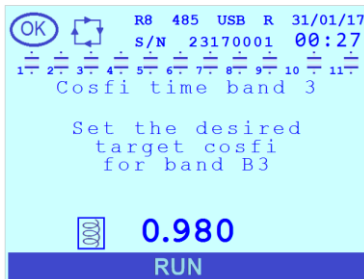

This parameter defines the target cosfi value in **Band B3**. The default value is "0,980", inductive. The permitted range for the numerical value is [0,500÷1,000]. It is also possible to set a load, both inductive and capacitive, by changing the symbol on the left of the numerical value.

NOTE 1: This parameter and the **Cosfi tolerance** parameter define together the value range within which the controller will consider the system as corrected in **Band B3** and, consequently, also the activation thresholds for undercompensation and overcompensation alarms.

NOTE 2: this parameter is significant only if a **Band B3** (Chap.7.2.8) has been set.

7.2.5 Cosfi TB4/GEN

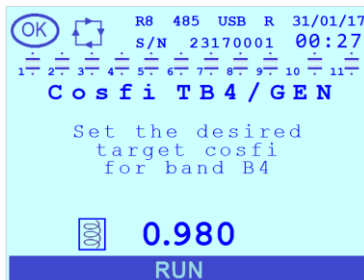

This parameter defines the target cosfi value in **Band B4** (if **Cogeneration** = "DISABLED" or if **Cogeneration** = "ENABLED" and **Step disconnection** = "ENABLED") or the target cosfi value with system in generation (if **Cogeneration** = "ENABLED" and **Step disconnection** = "DISABLED" (see Chap.7.1.5 and Chap. 7.3.5)). The default value is "0,980", inductive. The permitted range for the numerical value is [0,500÷1,000]. It is also possible to set a load, both inductive and capacitive, by changing the symbol on the left of the numerical value.

NOTE 1: This parameter and the **Cosfi tolerance** parameter define together the value range within which the controller will consider the system as corrected in **Band B4** or in generation (based on the above-mentioned conditions) and, consequently, also the activation thresholds for undercompensation and overcompensation alarms.

NOTE 2: the parameter is significant only if a **Band B4** has been set or if the system is in generation (based on the above-mentioned conditions).

7.2.6 Band B1



This parameter defines the start time of the first time band B1. The default value is "00:00:00". The permitted range for the numerical value is [00:00:00÷23:59:00]. In this band the **Target cosfi** and **Cosfi tolerance** parameters jointly define the value range within which the controller will consider the system corrected.

Please note that the start time of a time band coincides with the end of the previous one.



7.2.7 Band B2



This parameter defines the start time of the second time band B2. The default value is "99:99:00" corresponding to its deactivation. The permitted range for the numerical value is [00:00:00÷23:59:00]. In this band the **Cosfi time band 2** and **Cosfi tolerance** parameters jointly define the value range within which the controller will consider the system corrected.

Please note that the start time of the time band B2 coincides with the end of the previous time band B1.

7.2.8 Band B3



This parameter defines the start time of the third time band B3. The default value is "99:99:00" corresponding to its deactivation. The permitted range for the numerical value is [00:00:00÷23:59:00]. In this band the **Cosfi time band 3** and **Cosfi tolerance** parameters jointly define the value range within which the controller will consider the system corrected.

Please note that the start time of the time band B3 coincides with the end of the previous time band B2.

7.2.9 Band B4



This parameter defines the start time of the fourth time band B4. The default value is "99:99:00" corresponding to its deactivation. The permitted range for the numerical value is [00:00:00÷23:59:00]. In this band the **Cosfi TB4/GEN** and **Cosfi tolerance** parameters jointly define the value range within which the controller will consider the system corrected.

NOTE: if **Cogeneration** = "ENABLED" and **Step disconnection** = "DISABLED" **Band B4** is no longer valid. Consequently, the corresponding time range will inherit the target cosfi value **Cosfi time band 3** of the previous **Band B3**.

Please note that the start time of the time band B4 coincides with the end of the previous time band B3.

7.2.10 Avg. integrat. time

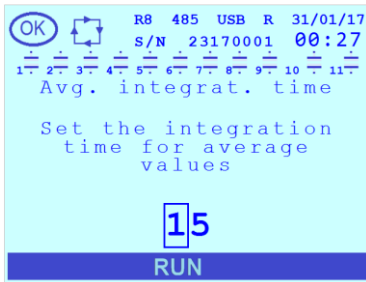

The default value is "15". The permitted range for the parameter is [1÷60] minutes.



Example: if it is necessary to obtain the average value of powers every 5 minutes set the value 5.

7.3 Power factor correction settings

In this section it is possible to:

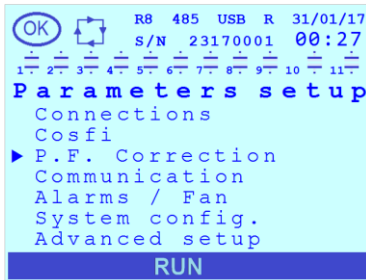

- set the shared parameters relevant to all capacitor banks (rated voltage, discharge time and connection, disconnection time in case of system in generation);
- set the parameters specific for each capacitor bank (rated power, bank operating mode);
- set the relay outputs as alarm, signalling output or fan output;
- set the manual correction mode and the relevant configuration of the relays.

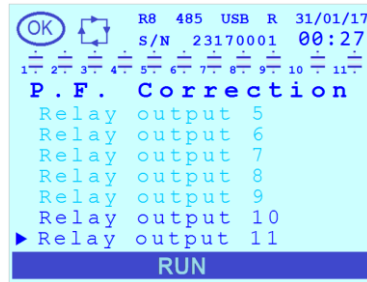
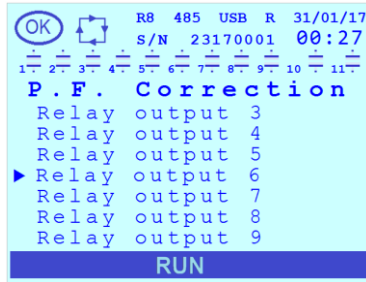
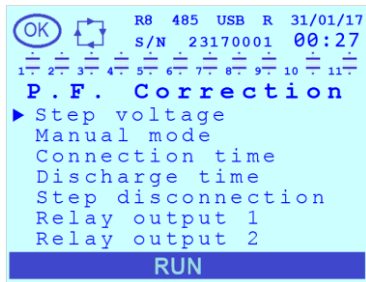

In the "Setup" menu, through keys  or , move the cursor on "P.F. Correction" and press key .



The "P.F. Correction" menu contains the following items: Step voltage, Manual mode, Connection time, Discharge time, Step disconnection and Relay output n (n=1÷11).

Through the keys  or , move the cursor on the relevant item and press key  to view it and/or change it.

To exit the page relevant to a parameter and/or go back to the previous menu press key .

Refer to [Chap. 7.9](#) for the indications on the setting modes of the parameter values.

7.3.1 Step voltage

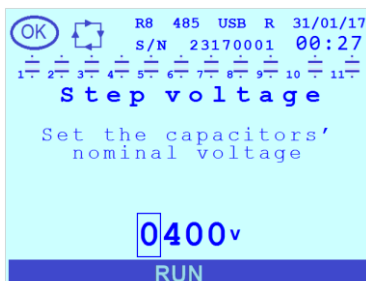

This parameter defines the nominal voltage of the capacitors. The default value is "400". The permitted range for the parameter is [50÷5000]V.

If the controller is installed on a Ducati energia power factor correction equipment, the value to be entered is the one specified on equipment plate.

WARNING: If blocking reactors (or equivalent devices) are present, it is recommended to set the same value of network nominal voltage (i.e. 400V); in these cases, also bank reactive power value must be set to the network voltage equivalent value (and not to the nominal value). For further details on settings in case of blocking reactors, refer to [Chap. 8.11 - Presence of blocking reactors](#).



7.3.2 Manual mode

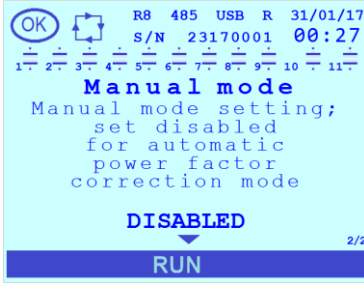

The default value is "DISABLED". The permitted values for the parameter are [DISABLED; ENABLED].

To manually set capacitor activation status, set this parameter to "ENABLED".

NOTE: as an alternative, the **Manual power factor correction mode** can be enabled (or disabled) from any page of the Measurement Menu by keeping key  pressed for 2sec.

If the parameter is edited from "DISABLED" to "ENABLED", the user will have to set the output status by confirming or editing it in the pages displayed after. Sequence detailed description is specified in [Chap. 8.10 - Manual power factor correction mode](#). During the procedure and at the end of the same, the icon relevant to the operating mode will switch to

manual (hand): 

If the parameter is edited from "ENABLED" to "DISABLED", the automatic power factor correction algorithm will define the bank status, based on the specified function through the associated **Step n function (n=1÷11)** parameter, for further details refer to [Chap.7.3.6.1](#)

The icon of the operating mode will switch to automatic:



7.3.3 Connection time



The default value is "60". The permitted range for the parameter is [1÷30000]sec.

The parameter defines the minimum time between two operations (activation and deactivation) on different banks. Set a lower value if the reactive power to be corrected quickly varies. Set a higher value if the reactive power to be corrected slowly varies.

7.3.4 Discharge time



The default value is "60". The permitted range for the parameter is [1÷30000]sec.

The parameter defines the waiting time for the reconnection of the bank after its disconnection in order to guarantee full discharge.

ATTENTION: the **Discharge time** parameter must be set consistently with the indications given in the power factor correction equipment manual. Entering a time shorter than the recommended one can lead to equipment and/or controller damage.

7.3.5 Step disconnection

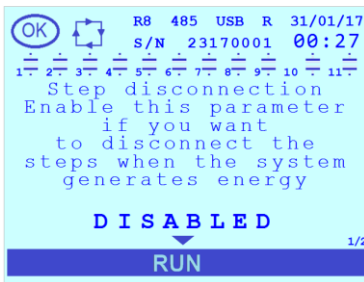

The default value is "DISABLED". The permitted values for the parameter are [DISABLED; ENABLED].

By enabling the parameter, if the system switches to energy generation status, the controller will disconnect all the activated capacitor banks (relay outputs for which the **Step n function (n=1÷11)** is set to "STEP" or "ALWAYS ON STEP").





7.3.6 Relay output n (n=1÷11)

This menu item is present for all relays (8 or 11 depending on the model). Position the cursor on one of them and press the key  to view an additional parameter list that will be filled in dynamically according to the type of function associated with the relay and to the operating mode (automatic or manual) of the controller.

- If the controller is in **automatic power factor correction mode (Manual mode = "DISABLED")**:
 - the **Step n function (n=1÷11)** parameter will be displayed in all cases, this will be the only parameter displayed for all relay outputs, where parameter **Step n function (n=1÷11)** is one among "FAN OUTPUT", "MAN/AUT OUTPUT" or "R8 RUNNING (RUN)".

The following will also be displayed:

- the **Step Cn power (n=1÷11)** parameter will be displayed for all relay outputs, where parameter **Step n function (n=1÷11)** is one among "STEP", "ALWAYS ON STEP" or "ALWAYS OFF STEP";
- the **Alarm output n (n=1÷11)** parameter, for all relay outputs where parameter **Step n function (n=1÷11)** is one between "N.O. CONTACT ALARM" or "N.C. CONTACT ALARM";
- Should the controller be in **manual power factor correction mode (Manual mode = "ENABLED")** the list will contain all the elements previously listed with the addition of parameter **Manual status Cn (n=1÷11)**.

Through the keys  or , move the cursor on the relevant item and press key  to view it and/or change it.

Following are the screens with the parameters displayed in all possible case scenarios (example with **Relay 1 output**):

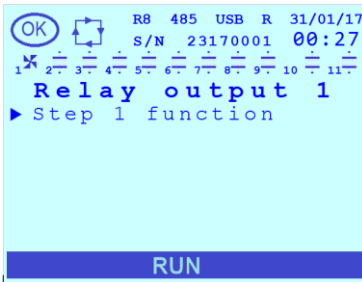

Automatic power factor correction mode, **Step n function (n=1÷11)** set to "FAN OUTPUT", "MAN/AUT OUTPUT" or "R8 RUNNING (RUN)".



Automatic power factor correction mode, **Step n function (n=1÷11)** set to "STEP", "ALWAYS ON STEP" or "ALWAYS OFF STEP".

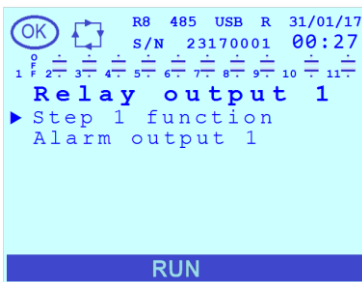

Automatic power factor correction mode, **Step n function (n=1÷11)** set to "N.O. CONTACT ALARM" or "N.C. CONTACT ALARM"

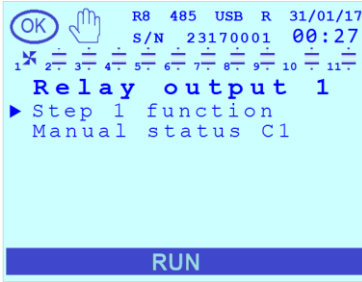

Manual power factor correction mode, **Step n function (n=1÷11)** set to "FAN OUTPUT", "MAN/AUT OUTPUT" or "R8 RUNNING (RUN)".

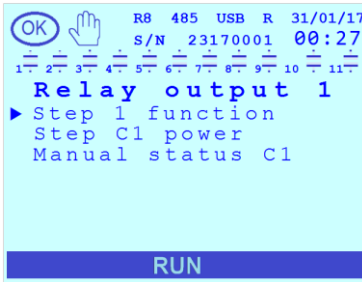

Manual power factor correction mode, **Step n function (n=1÷11)** set to "STEP", "ALWAYS ON STEP" or "ALWAYS OFF STEP".

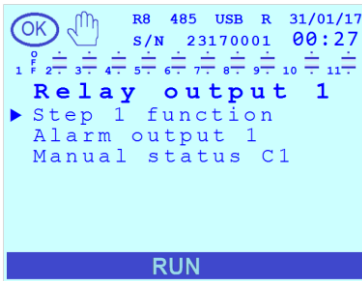

Manual power factor correction mode, **Step n function (n=1÷11)** set to "N.O. CONTACT ALARM" or "N.C. CONTACT ALARM".

7.3.6.1 Step n function (n=1÷11)



The default value is "STEP". The permitted values for the parameter are [STEP; ALWAYS ON STEP; ALWAYS OFF STEP; N.O. CONTACT ALARM; N.C. CONTACT ALARM; FAN OUTPUT; MAN/AUT OUTPUT; R8 RUNNING (RUN)].

NOTE 1: it is possible to assign the value "R8 RUNNING (RUN)" only to the relay with NO/NC contacts. (output 8 for models with 8 relays and output 11 for models with 11 relays).

NOTE 2: based on the associated function, the icon representing the relay output in the status bar at the top of the screen will become as described in **Chap.8.2.1**.

Select the value:

- "STEP" for an output connected to a capacitor bank that you want to be automatically piloted by the controller;
- "ALWAYS ON STEP" for an output connected to a bank that you want to keep always on;
- "ALWAYS OFF STEP" for an output not connected or connected to a bank that you do not want to use;
- "NO ALARM CONTACT" for an output used as normally open alarm contact;
- "N.C. CONTACT ALARM" for an output used as normally closed alarm contact;
- "FAN OUTPUT" for an output used to activate a fan;
- "MAN/AUT OUTPUT" for an output that closes when manual power correction mode is selected and opens when automatic power factor correction is selected;
- "R8 RUNNING (RUN)" for an output that closes when the controller is operating regularly.

Should the controller be in **manual power factor correction mode (Manual mode = "ENABLED")**, parameter **Step n function (n=1÷11)** will be in read-only mode.



7.3.6.2 Step Cn power (n=1÷11)

NOTE: the **Step Cn power (n=1÷11)** parameter is displayed only for relay outputs for which parameter **Step n function (n=1÷11)** has been set to one among "STEP", "ALWAYS ON STEP" or "ALWAYS OFF STEP". For further details, refer to [Chap.7.3.6.1](#).



The default value is "0". The permitted range for the parameter is [0÷9999.9]kVar.

If the controller is installed on a Ducati energia power factor correction equipment, the value to be entered is the one specified on equipment plate.

7.3.6.3 Alarm output n (n=1÷11)

NOTE: the **Alarm output n (n=1÷11)** parameter is displayed only for relay outputs for which parameter **Step n function (n=1÷11)** has been set to one between "N.O. CONTACT ALARM" or "N.C. CONTACT ALARM". For further details, refer to [Chap.7.3.6.1](#).

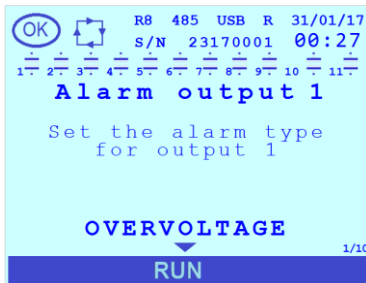

The default value is "OVERVOLTAGE". The permitted values for the parameter are [OVERVOLTAGE; OVERCURRENT; LOW VOLTAGE; LOW CURRENT; OVERCOMPENSATION; UNDERCOMPENSATION; HIGH TEMPERATURE; HIGH THDV%; HIGH THDI%, GENERIC].

Select the value:

- "OVERVOLTAGE" to associate the relay n output to the overvoltage alarm:
(for further details refer to [Chap. 7.5.1 - Overvoltage alarm threshold](#) and [Chap. 7.5.2 - Overvoltage alarm delay](#)).
- "OVERCURRENT" to associate the relay n output to the overcurrent alarm:
(for further details refer to [Chap. 7.5.3 - Overcurrent alarm threshold](#) and [Chap. 7.5.4 - Overcurrent alarm delay](#)).
- "LOW VOLTAGE" to associate the relay n output to the low voltage alarm:
(for further details refer to [Chap. 7.5.5 - Low voltage alarm threshold](#) and [Chap. 7.5.6 - Low voltage alarm delay](#)).
- "LOW CURRENT" to associate the relay n output to the low current alarm:
(for further details refer to [Chap. 7.5.7 - Low current alarm threshold](#) and [Chap. 7.5.8 - Low current alarm delay](#)).
- "OVERCOMPENSATION" to associate the relay n output to the overcompensation alarm:
(for furth.det.ref.to [Chap. 7.2 - Cosfi settings](#) and [Chap. 7.5.13 - Overcompensation alarm delay](#)).
- "UNDERCOMPENSATION" to associate the relay n output to the undercompensation alarm:
(for furth.det.ref.to [Chap. 7.2 - Cosfi settings](#) and [Chap. 7.5.14 - Undercompensation alarm delay](#)).
- "HIGH TEMPERATURE" to associate the relay n output to the high temperature alarm:
(for further details refer to [Chap. 7.5.15 - Temperature alarm threshold](#) and [Chap. 7.5.16 - Temperature alarm delay](#)).
- "HIGH THDV%" to associate the relay n output to the high THDV% alarm:
(for further details refer to [Chap. 7.5.9 - THDV% alarm threshold](#) and [7.5.10 - THDV% alarm delay](#)).
- "HIGH THDI%" to associate the relay n output to the high THDI% alarm:
(for further details refer to [Chap. 7.5.11 - THDI% alarm threshold](#) and [Chap. 7.5.12 - THDI% alarm delay](#)).
- "GENERIC" to associate the relay n output with at least one of the previous alarms present.



7.3.6.4 Manual status Cn (n=1÷11)

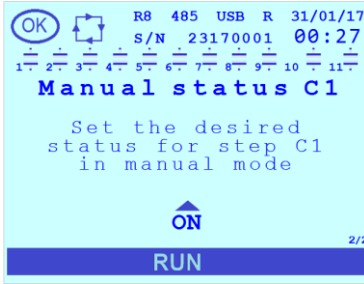

NOTE: parameter **Manual status Cn (n=1÷11)** is displayed only if the controller is in **manual power factor correction mode (Manual mode = "ENABLED")**.

The permitted values for the parameter are [OFF; ON].

For the outputs for which it has been set **Step n function (n=1÷11)** = "MAN/AUT OUTPUT", while **Manual status Cn (n=1÷11)** = "OFF" and in read-only mode.

For the remaining relay outputs the default value is inherited from the output status during automatic operation, immediately before switching to **Manual power factor correction mode** (for details see [Chap. 8.10](#)).

GO BACK TO [SETTINGS](#)

GO BACK TO [CONTENTS](#)

7.4 Communication interface settings

In this section it is possible to:



- set the RS485 communication parameters (in the models with this feature, in the models without this feature they remain still present but with no effect);
- get information on the NFC interface;
- define the operations to carry out through the USB port (in the models with this feature);
- set the Ethernet communication parameters (in the models with this feature).



In the "Setup" Menu, through keys  or , move the cursor on "**Communication**" and press key .



The "**Communication**" menu contains the following items: **Protocol**, **Address**, **Baudrate**, **NFC information**, **USB** and **Ethernet**.

Through the keys  or , move the cursor on the relevant item and press key  to view it and/or change it.

To exit the page relevant to a parameter and/or go back to the previous menu press key .

Refer to **Chap. 7.9** for the indications on the setting modes of the parameter values.

7.4.1 Protocol

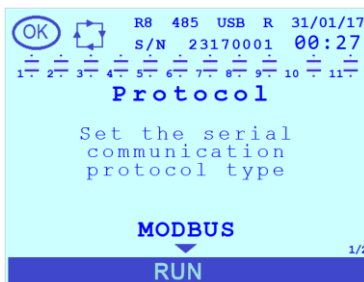

The parameter defines the protocol type to be used for the RS485 serial communication (where present).

The default value is "MODBUS". The permitted values for the parameter are [MODBUS; ASCII, DUCBUS].

Select:

- "MODBUS" to set the Modbus-RTU protocol;
- "ASCII DUCBUS" to set the ASCII Ducbus protocol.

NOTE: if the **Address** parameter is set to a value greater than "98" and **Protocol** is changed from "MODBUS" to "ASCII DUCBUS", the default value ("31") will be automatically restored.

For detailed information on Modbus-RTU and ASCII Ducbus protocol specifications, refer to the documents available at the following link: ftp://ftp.ducatienergia.com/DucatiSistemi/Protocols_Analysers/

7.4.2 Address

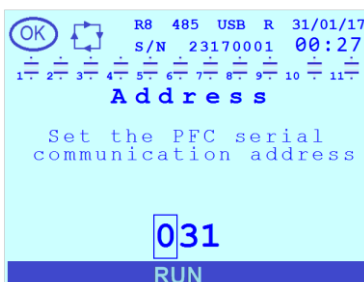

The parameter defines the address to be used for the RS485 serial communication (where present).

The default value is "31". If the **Protocol** parameter is set to "MODBUS" the permitted range is [1÷247], while if it is set to "ASCII DUCBUS", the permitted range is [1÷98].

NOTE: if the parameter is set to a value greater than "98" and **Protocol** is changed from "MODBUS" to "ASCII DUCBUS", the default value ("31") will be automatically restored.



7.4.3 Baudrate



The parameter defines the baudrate to be used for the RS485 serial communication (where present).

The default value is "9600". The permitted values for the parameter are [115200; 57600; 38400; 19200; 9600]bps.

7.4.4 NFC information

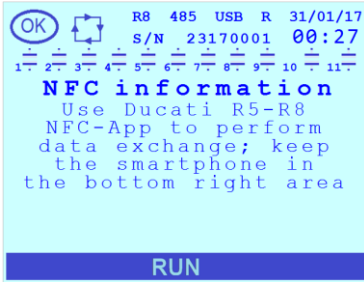

The page is in read-only mode and contains information on the NFC communication interface.

7.4.5 USB

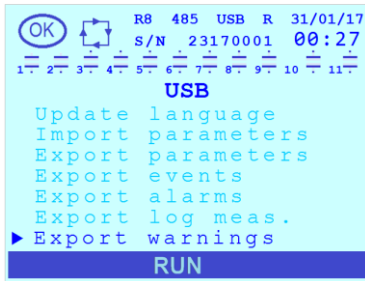
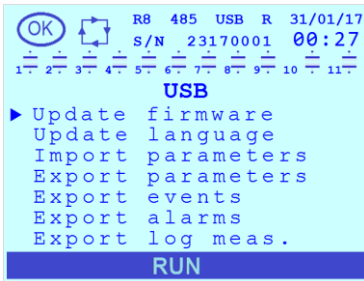

This menu item is displayed only for models that feature the USB interface.

Select it and press the key  to display an additional parameter list that will contain a series of reading/writing commands on the connected USB pendrive.



The commands are: Update firmware, Update language, Import parameters, Export parameters, Export events, Export alarms, Export log meas., Export warnings.

Once the pendrive is connected and acknowledged, the active USB connection icon will be displayed steady on in the status bar at the bottom of the display. 

Through the keys  or , move the cursor on the relevant item and press key  to execute the command. Generally speaking, at the moment of the execution, for each one of the previous commands:



If no USB pendrive is connected, or at the end of an operation that was not carried out successfully, an error message will be displayed for 3 seconds.

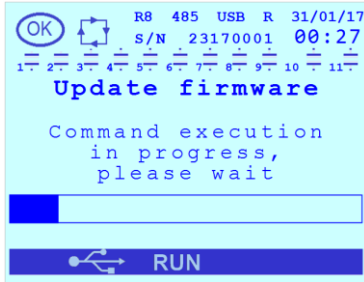

During the execution of a command an information message indicating that the requested operation is in progress will be displayed. In the lower part there will be displayed a bar indicating the progress of the operation.

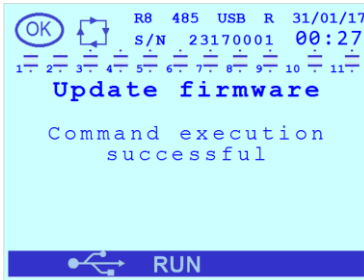

At the end of the execution of a command a confirmation message will be displayed.

During the execution of a command the USB connection icon will be flashing.

7.4.5.1 Update firmware

Select this command to update the firmware (and the bootloader) of the R8 Controller.

To perform this operation it is necessary to previously:

- create the "FW" folder on the pendrive;
- copy the update binary file "R8_BL_X_Y_FMW_Z_WW.bin" (X and Y define the bootloader release version, Z and WW the firmware release version) that can be found at the following link: https://ducnet.ducatienergia.com/firm_rego/R8/.

7.4.5.2 Update language

Select this command to update the menu languages of the R8 Controller.

To perform this operation it is necessary to previously:

- create the "LANG" folder on the pendrive;
- copy the update binary file "FontStr_vX_YY.bin" (X and Y define the language release version) that can be found at the following link: https://ducnet.ducatienergia.com/firm_rego/R8/.

7.4.5.3 Import parameters

Select this command to import a complete set of parameters of the R8 Controller.

To perform this operation it is necessary to previously:

- create the "PARAM" folder on the pendrive;
- copy the .csv file exported from another R8 controller or available at the following link: https://ducnet.ducatienergia.com/firm_rego/R8/.

7.4.5.4 Export parameters

Select this command to export a complete set of parameters of the R8 Controller.

The operation will save a "PARAM.CSV" file on the pendrive in the "\PARAM" folder.

7.4.5.5 Export events

Select this command to export system events (e.g. power-on, parameter change, firmware or language update, movements of the relay outputs defined as "STEP") of the R8 Controller.

The operation will save a "TIME_E.CSV" file on the pendrive in the "\SN\DATE" folder where:

- SN is an 8-digit number corresponding to the serial number of the Controller;
- DATE is the date at the moment of the saving in YY_MM_DD format;
- TIME is the time at the moment of the saving in HHMMSS format.

7.4.5.6 Export alarms

Select this command to export the alarm log of the R8 Controller.

The operation will save a "TIME_A.CSV" file on the pendrive in the "\SN\DATE" folder where:

- SN is an 8-digit number corresponding to the serial number of the Controller;
- DATE is the date at the moment of the saving in YY_MM_DD format;
- TIME is the time at the moment of the saving in HHMMSS format.

7.4.5.7 Export log meas

Select this command to export the log of the measurements chosen through parameters **Log first meas.** (Chap. 7.7.23) and **Log second meas.** (Chap. 7.7.24).

NOTE: the measurement log must be enabled in advance through parameter **Log enable** (Chap. 7.7.26).

The operation will save a "TIME_L.CSV" file on the pendrive in the "\SN\DATE" folder where:

- SN is an 8-digit number corresponding to the serial number of the Controller;
- DATE is the date at the moment of the saving in YY_MM_DD format;
- TIME is the time at the moment of the saving in HHMMSS format.

7.4.5.8 Export warnings

Select this command to export the warning log (e.g. bank degradation) of the R8 Controller.

The operation will save a "TIME_W.CSV" file on the pendrive in the "\SN\DATE" folder where:

- SN is an 8-digit number corresponding to the serial number of the Controller;
- DATE is the date at the moment of the saving in YY_MM_DD format;
- TIME is the time at the moment of the saving in HHMMSS format.

7.4.6 Ethernet

This menu item is displayed only for models that feature the Ethernet interface.

Select it and press the key  to display an additional parameter list.

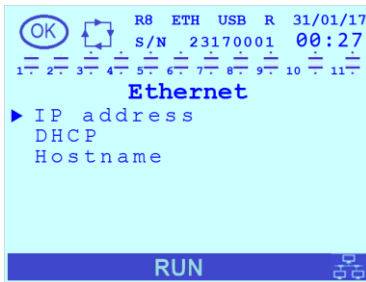

The menu contains the following items: **IP address**, **DHCP** and **Hostname**.

In case of active incoming connection, the Ethernet icon will appear permanently in the status bar at the bottom of the display. 

Information about the configuration of the Ethernet interface and its main functions (Modbus-TCP communication protocol and Webserver via HTTP protocol) can be found in the "Webserver and Modbus-TCP R8 ETH" manual available online at the link: <https://www.ducatienergia.com/product.php?lang=en&id=8&cat=13&product=91>

GO BACK TO **SETTINGS**

GO BACK TO **CONTENTS**

7.5 Alarms and fan activation settings

The parameters in this section allow defining the threshold and delay time parameters of alarms and fan activation.

Generally speaking, the activation of the alarm and/or fan occurs after the corresponding measurement exceeds the activation threshold for at least the associated delay time. Similarly, the deactivation occurs after that the corresponding measurement falls back within the threshold for at least the associated delay time. However, there are some exceptions. For details refer to the description of the single alarms in the following sub-chapters and in [Chap. 8.7](#)

It is also possible to mask the alarm display and signalling; for details see [Chap. 8.7](#) and [Chap.7.7.22](#).

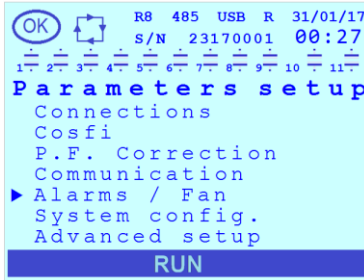



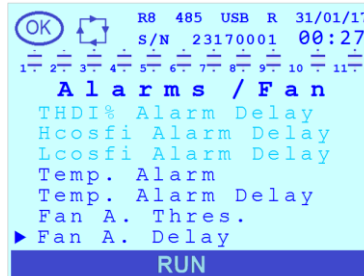
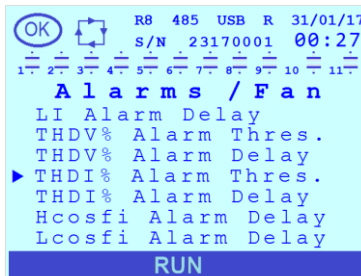
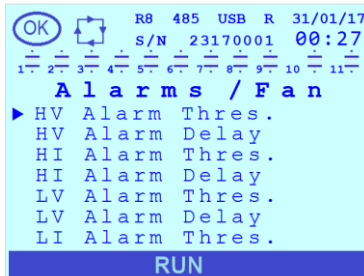

In the "Setup" Menu, through keys  or , move the cursor on "**Alarms / Fan**"

and press key .



The "**Alarms / Fan**" menu contains the following items: HV Alarm Thres., HV Alarm Delay, HI Alarm Thres., HI Alarm Delay, LV Alarm Thres., LV Alarm Delay, LI Alarm Thres., LI Alarm Delay, THDV% Alarm Thres., THDV% Alarm Delay, THDI% Alarm Thres., THDI% Alarm Delay, Hcosfi Alarm Delay, Lcosfi Alarm Delay, Temp. Alarm, Temp. Alarm Delay and Fan A. Thres., Fan A. Delay.

Through the keys  or , move the cursor on the relevant item and press key  to view and/or change it.

To exit the page relevant to a parameter and/or go back to the previous menu press key .

Refer to [Chap. 7.9](#) for the indications on the setting modes of the parameter values.

7.5.1 Overvoltage alarm threshold (HV Alarm Thres.)

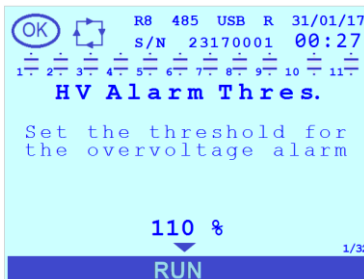

Select HV Alarm Thres. to set the overvoltage alarm threshold.

The default value is "110%". The permitted values for the parameter will range from 80% to 110% of the value set for parameter VT primary with a 1% resolution. To disable the alarm select the "OFF" value.



7.5.2 Overvoltage alarm delay (HV Alarm Delay)

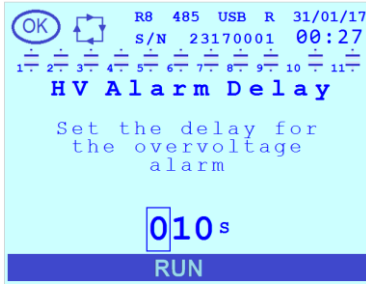

Select **HV Alarm Delay** to set the overvoltage alarm delay.

The default value is "10". The permitted range for the parameter is [1÷255] s.

NOTE: the alarm will be activated and deactivated if the reference measurement steadily stays above or under the threshold for the time set.

7.5.3 Overcurrent alarm threshold (HI Alarm Thres.)

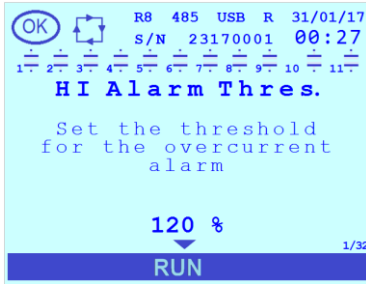

Select **HI Alarm Thres.** to set the overcurrent alarm threshold.

The default value is "120%". The permitted values for the parameter will range from 90% to 120% of the value set for parameter **CT primary** with a 1% resolution. To disable the alarm select the "OFF" value.

7.5.4 Overcurrent alarm delay (HI Alarm Delay)

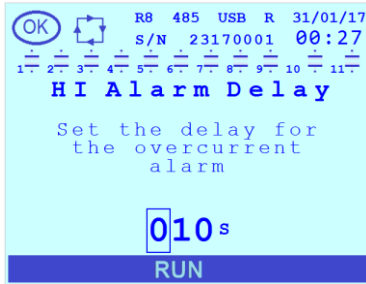

Select **HI Alarm Delay** to set the overcurrent alarm delay.

The default value is "10". The permitted range for the parameter is [1÷255] s.

NOTE: the alarm will be activated and deactivated if the reference measurement steadily stays above or under the threshold for the time set.

7.5.5 Low voltage alarm threshold (LV Alarm Thres.)



Select **LV Alarm Thres.** to set the low voltage alarm threshold.

The default value is "OFF". The permitted values for the parameter will range from 80% to 110% of the value set for parameter **VT primary** with a 1% resolution. To disable the alarm select the "OFF" value.

7.5.6 Low voltage alarm delay (LV Alarm Delay)

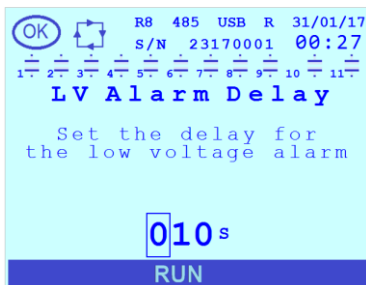

Select **LV Alarm Delay** to set the low voltage alarm delay.

The default value is "10". The permitted range for the parameter is [1÷255] s.

NOTE: the alarm will be activated and deactivated if the reference measurement steadily stays above or under the threshold for the time set.



7.5.7 Low current alarm threshold (LI Alarm Thres.)

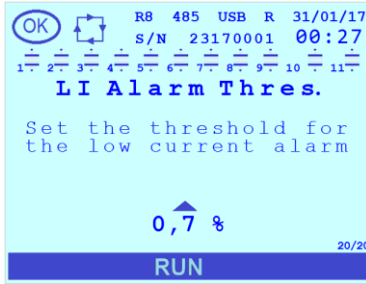

Select **LI Alarm Thres.** to set the low current alarm threshold.

The default value is "0.7%". The permitted values for the parameter will range from 0.7% to 10% of the value set for parameter **CT primary** with a 0.5% resolution. The alarm cannot be disabled.

7.5.8 Low current alarm delay (LI Alarm Delay)

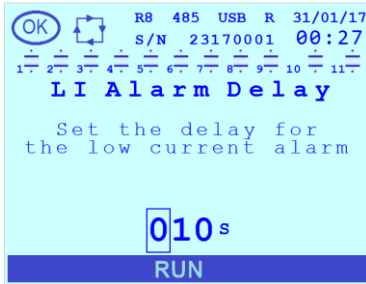

Select **LI Alarm Delay** to set the low current alarm delay.

The default value is "10". The permitted range for the parameter is [1÷255] s.

NOTE: the alarm will be activated and deactivated if the reference measurement steadily stays above or under the threshold for the time set.

7.5.9 THDV% alarm threshold (THDV% Alarm Thres.)

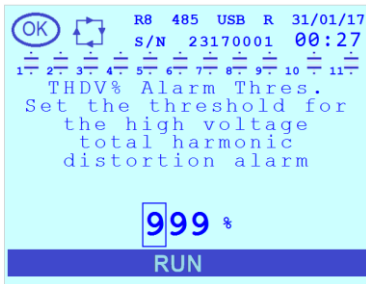

Select **THDV% Alarm Thres.** to set the high THDV alarm threshold.

The default value is "999". The permitted range for the parameter is [1÷100]%. To disable the alarm enter value "999"

7.5.10 THDV% alarm delay (THDV% Alarm Delay)

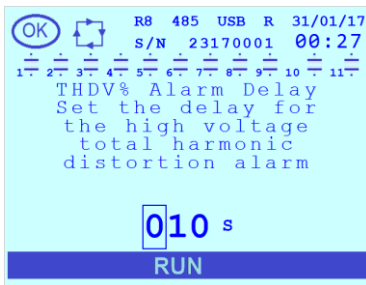

Select **THDV% Alarm Delay** to set the high THDV alarm delay.

The default value is "10". The permitted range for the parameter is [1÷255] s.

NOTE: the alarm will be activated and deactivated if the reference measurement steadily stays above or under the threshold for the time set.

7.5.11 THDI% alarm threshold (THDI% Alarm Thres.)



Select **THDI% Alarm Thres.** to set the high THDI alarm threshold.

The default value is "999". The permitted range for the parameter is [1÷100]%. To disable the alarm enter value "999"



7.5.12 THDI% alarm delay (THDI% Alarm Delay)

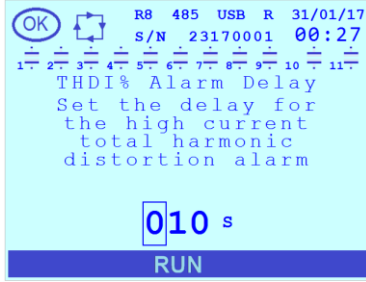

Select **THDI% Alarm Delay** to set the high THDI alarm delay.

The default value is "10". The permitted range for the parameter is [1÷255] s.

NOTE: the alarm will be activated and deactivated if the reference measurement steadily stays above or under the threshold for the time set.

7.5.13 Overcompensation alarm delay (Hcosfi Alarm Delay)

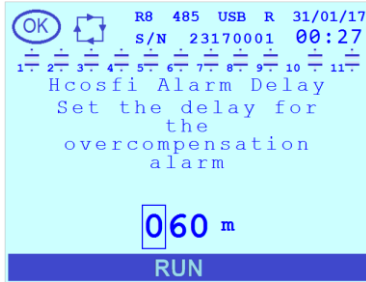

Select **Hcosfi Alarm Delay** to set the overcompensation alarm delay.

The default value is "60". The permitted range for the parameter is [1÷255] minutes.

NOTE: the alarm will activate if the cosfi measurement remains stable above the higher threshold (more capacitive) of the value target range within which the controller will consider the system corrected for the time set. The range is defined by parameters **Target cosfi** (or **Cosfi Time band 2**, **Cosfi Time band 3** or **Cosfi TB4/GEN** according to current time band and the operating mode set in case of system in generation, refer to **Chap. 7.2** and **Chap.7.3**) and **Cosfi tolerance**. As soon as the cosfi drops below the higher threshold (more capacitive) of the target range, the alarm will deactivate.

7.5.14 Undercompensation alarm delay (Lcosfi Alarm Delay)

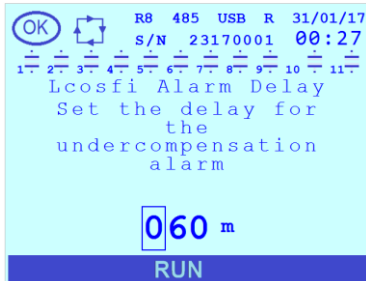

Select **Lcosfi Alarm Delay** to set the undercompensation alarm delay.

The default value is "60". The permitted range for the parameter is [1÷255] minutes.

NOTE: the alarm will activate if the cosfi measurement remains stable under the lower threshold (more inductive) of the value target range within which the controller will consider the system corrected for the time set. The range is defined by parameters **Target cosfi** (or **Cosfi Time band 2**, **Cosfi Time band 3** or **Cosfi TB4/GEN** according to current time band and the operating mode set in case of system in generation, refer to **Chap. 7.2** and **Chap.7.3**) and **Cosfi tolerance**. As soon as the cosfi rises above the lower threshold (more inductive) of the target range, the alarm will deactivate.

7.5.15 Temperature alarm threshold (Temp. Alarm)

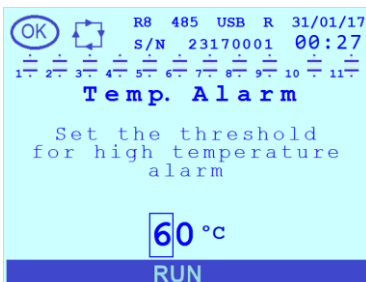

Select **Temp. Alarm** to set the temperature too high alarm threshold.

The default value is 60°C (140°F). The permitted range for the parameter is [0÷80]°C ([32÷176]°F).



7.5.16 Temperature alarm delay (Temp. Alarm Delay)

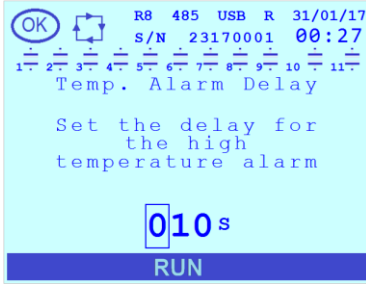

Select **Temp. Alarm Delay** to set the temperature alarm delay.

The default value is "10". The permitted range for the parameter is [1÷255] s.

NOTE: the alarm will be activated and deactivated if the reference measurement steadily stays above or under the threshold for the time set.

7.5.17 Fan activation threshold (Fan A. Thres.)

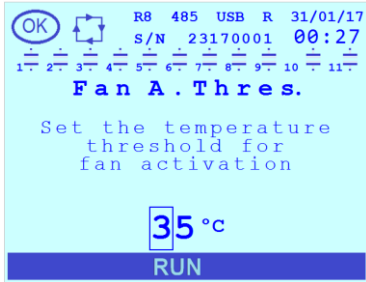

Select **Fan A. Thres.** to set the temperature threshold above which the relay outputs will be activated, where **Step n function (n=1÷11)** = "FAN OUTPUT".

The default value is 35°C (95°F). The permitted range for the parameter is [0÷80]°C ([32÷176]°F).

7.5.18 Fan activation delay (Fan A. Delay)

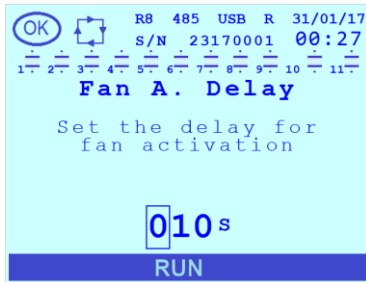

Select **Fan A. Delay** to set the activation delay of the relay outputs, where **Step n function (n=1÷11)** = "FAN OUTPUT".

The default value is "10". The permitted range for the parameter is [1÷255] s.

NOTE: the fan will be activated if the temperature steadily stays above the threshold for the time set. A hysteresis will cause the deactivation that will occur if the temperature remains stable below the threshold decreased by 10°C (18°F) for the set time.

GO BACK TO **SETTINGS**



GO BACK TO **CONTENTS**

7.6 System settings

In this section it is possible to:

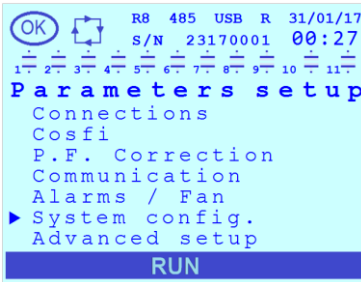

- set the language, temperature unit, date, time and summertime parameters;
- set and activate the password;
- set display backlight and contrast;
- view the versions of the firmware, bootloader and languages installed on the Controller.

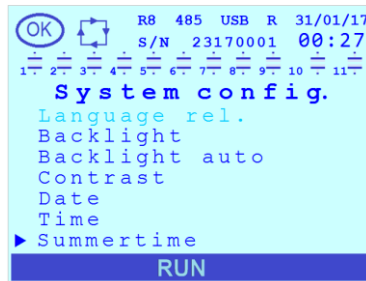
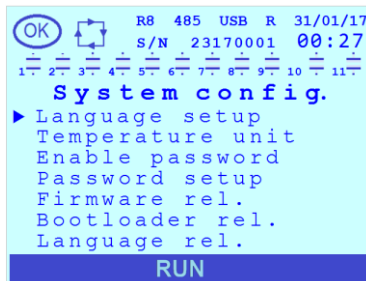

In the "Setup" Menu, through keys  or , move the cursor on "**System config.**" and press key .



The "**System config.**" menu contains the following items: **Language setup**, **Temperature unit**, **Enable password**, **Password setup**, **Firmware rel.**, **Bootloader rel.**, **Language rel.**, **Backlight**, **Backlight auto**, **Contrast**, **Date**, **Time** and **Summertime**.

Through the keys  or , move the cursor on the relevant item and press key  to view it and/or change it.

To exit the page relevant to a parameter and/or go back to the previous menu press key .

Refer to **Chap. 7.9** for the indications on the setting modes of the parameter values.

7.6.1 Language (Language setup)



Select **Language setup** to choose the menu language.

The default value is "ENGLISH". The permitted values for the parameter are [ENGLISH;ITALIANO;FRANÇAIS;ESPAÑOL;DEUTSCH;PORTUGUÊS;中文].

It is possible to update the languages, for further details, refer to **Chap. 8.12**.

NOTE: Should the loading of the system files containing the languages not be successful, the R8 Controller will use the integrated language in English.

7.6.2 Temperature unit

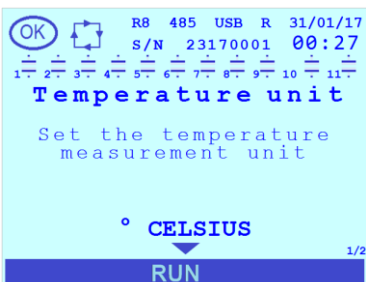

The default value is "CELSIUS".

The permitted values for the parameter are [° CELSIUS;° FAHRENHEIT].



7.6.3 Enable password



Select **Enable password** to enable the protection with password of parameters and reset functions.

The default value is "DISABLED". The permitted values for the parameter are [DISABLED; ENABLED].



NOTE: once set, the password is requested upon the next access to the Setup Menu or Reset Menu through a dedicated entry screen. Once entered, the password is valid for a session of 1 hour.

7.6.4 Password (Password setup)



The default value is "0000". The permitted range for the parameter is [0000-9999].

7.6.5 Firmware rel.



The page is in read-only mode and contains information on the firmware release version.

7.6.6 Bootloader rel.



The page is in read-only mode and contains information on the bootloader release version.



7.6.7 Language rel.



The page is in read-only mode and contains information on the release version of the language of the messages in the menus.

7.6.8 Backlight



The default value is "ON". The permitted values for the parameter are [OFF; ON].

7.6.9 Backlight auto



The parameter allows enabling the automatic backlight switch-off after 2 minutes of key inactivity.

The default value is "DISABLED". The permitted values for the parameter are [DISABLED; ENABLED].

7.6.10 Contrast

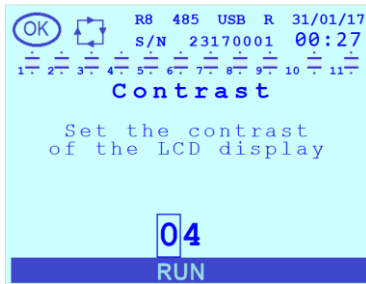

The default value is "4". The permitted range for the parameter is [0÷10].

The higher the numerical value entered, the higher the LCD contrast will be. Adjust the contrast also according to the backlight and the view angle.

7.6.11 Date



The default value (value displayed upon restart after the backup bank ran out) is 01/01/2017. The permitted range for the parameter is [01/01/1970÷31/12/2099].

NOTE: the parameter is always visible in read-only mode in the bar at the top right-hand side of the page (see the [Chap.8.2.1](#) relevant to the display).



7.6.12 Time

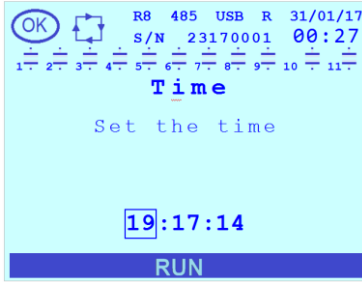

The default value (value displayed upon restart after the backup bank ran out) is 00:00:00. The permitted range for the parameter is [00:00:00÷23:59:59].

NOTE: the parameter is always visible in read-only mode in the bar at the top right-hand side of the page (see the [Chap.8.2.1](#) relevant to the display).

7.6.13 Summertime

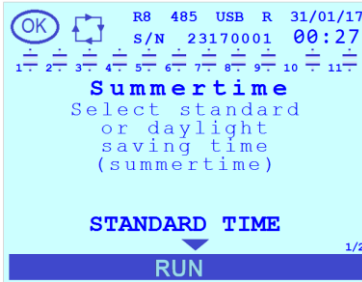

The default value (value displayed upon restart after the backup bank ran out) is "STANDARD TIME". The permitted values for the parameter are [STANDARD TIME; D.L. SAVING TIME].



GO BACK TO [SETTINGS](#)

GO BACK TO [CONTENTS](#)



7.7 Advanced settings

WARNING: if not expressly requested by this manual, the following parameters must be edited only by qualified staff and/or according to the indications provided by Ducati Energia technicians.

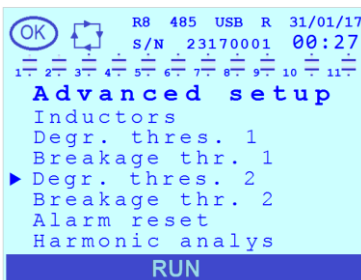
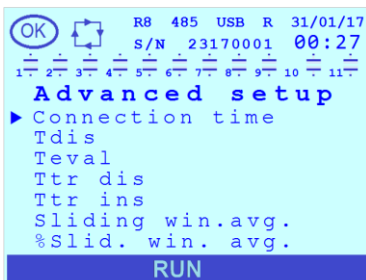

In the "Setup" Menu, through keys  or , move the cursor on "**Advanced setup**" and press key .



Through the keys  or , move the cursor on the relevant item and press key  to view it and/or change it.

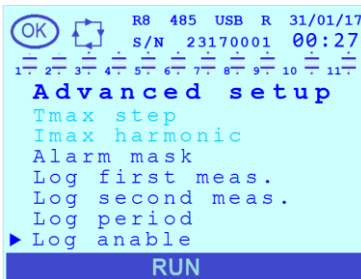

To exit the page relevant to a parameter and/or go back to the previous menu press key .

Refer to **Chap. 7.9** for the indications on the setting modes of the parameter values.

7.7.1 Connection time differentiation (Connection time)



The **Connection time** parameter allows enabling the connection time differentiation during insertion and disconnection.

The default value is "DISABLED". The permitted values for the parameter are [DISABLED; ENABLED].

If the differentiation is enabled, the connection time during insertion is defined by the **Connection time** parameter **Chap. 7.3.3** present in Setup Menu|Power factor correction while the connection time during disconnection is defined by the **Tdis** parameter **Chap. 7.7.2** present in the Setup Menu|Advanced setup.

7.7.2 Connection time in disconnection (Tdis)

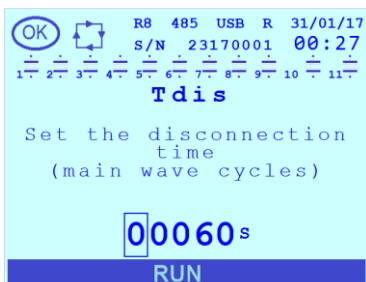

The **Tdis** parameter defines the connection time of the steps during disconnection only if the parameter (present in Setup menu|Advanced setup) **Connection time** = "ENABLED" **Chap. 7.7.1**. Otherwise, the time set by the **Connection time** parameter **Chap. 7.3.3** present in the Setup menu|Power factor correction applies.

The default value is "60". The permitted range for the parameter is [1÷30000] s.

7.7.3 Evaluation time (Teval)

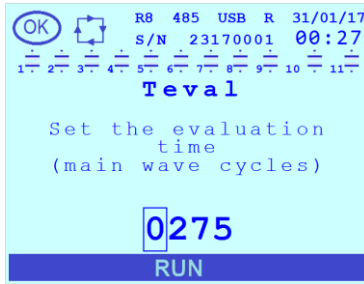

The "**Teval**" (Evaluation time) parameter defines the time duration (expressed in network periods) of permanence outside the target cosfi band (defined by the **Target cosfi** parameter [Chap. 7.2.1](#), or **Cosfi time band 2**, **Cosfi time band 3** or **Cosfi TB4/GEN** according to current time band and the operating mode set in case of system in generation, refer to [Chap. 7.2](#) and [Chap.7.3](#)) and **Cosfi tolerance** [Chap. 7.2.2](#)) beyond which the automatic power factor correction algorithm can make changes to the bank status. The lower the parameter value the faster the controller intervention will be.

The default value is "275". The permitted range for the parameter is [10÷1500] network periods.

7.7.4 Transient time during disconnection (Ttr dis)

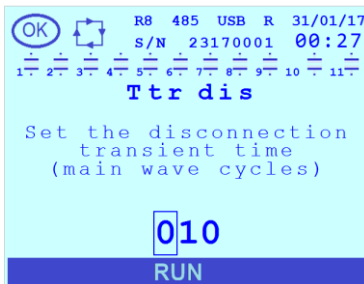

The **Ttr dis** parameter defines the time duration (expressed in network periods) of the electrical transient after the capacitor bank disconnection. Any change to this parameter must be consistent with what indicated in the technical documentation of the power factor correction equipment used.

The default value is "10". The permitted range for the parameter is [5÷250] network periods.

7.7.5 Transient time during insertion (Ttr ins)

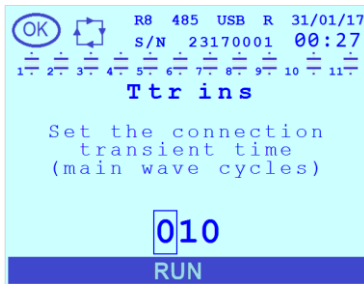

The **Ttr ins** parameter defines the time duration (in network periods) of the electrical transient after the capacitor bank insertion. Any change to this parameter must be consistent with what indicated in the technical documentation of the power factor correction equipment used.

The default value is "10". The permitted range for the parameter is [5÷250] network periods.

7.7.6 Measurement stability check (Sliding win.avg.)



The **Sliding win.avg.** parameter refers to the stability check of the active and reactive power instantaneous values (calculated on the last network period) compared to the average of the last 5 values (calculated in the last 5 network periods). If the control is enabled the automatic power factor correction algorithm will be inhibited if the % deviation between the instantaneous value and the average is higher than the value set through the parameter **%Slid. win. avg** described below in [Chap.7.7.7](#).

The default value is "ENABLED". The permitted values for the parameter are [DISABLED; ENABLED].

7.7.7 Measurement stability check threshold (%Slid. win. avg.)



The **%Slid. win. avg.** parameter defines the % deviation between the active and reactive power instantaneous values (calculated on the last network period) compared to the average of the last 5 values (calculated in the last 5 network periods) beyond which the automatic power factor correction algorithm is inhibited.

NOTE: the parameter is significant only if the parameter **Sliding win.avg.** previously described in [Chap.7.7.6](#) has been enabled.

The default value is "20". The permitted range for the parameter is [1÷50] network periods.



7.7.8 Inductor presence (Inductors)

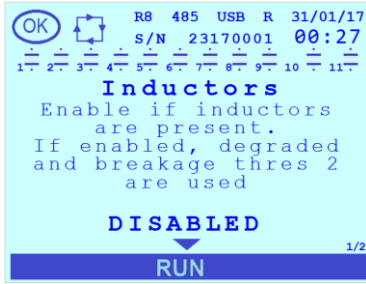

The **Inductors** parameter allows enabling the management of the bank status with inductors (or blocking reactors) presence; this management is carried out on the basis of the power measurements taken during insertion or disconnection of the same; if the parameter is set to "DISABLED" the controller uses the parameters **Degr. thres. 1** (Chap. 7.7.9) and **Breakage thr.1** (Chap.7.7.10), while if the parameter is set to "ENABLED" the controller uses the parameters **Degr. thres. 2** (Chap.7.7.11) and **Breakage thr.2** (Chap.7.7.12).

NOTE: for all information on the use of the controller in an equipment with blocking reactors follow the indications described in the chapter **Presence of blocking reactors** (Chap. 8.11).

The default value is "DISABLED". The permitted values for the parameter are [DISABLED; ENABLED].

7.7.9 Degr. thres. 1

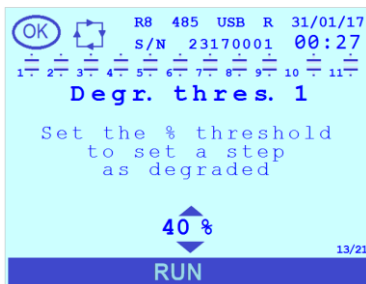

The **Degr. thres. 1** parameter defines the percentage decrement of the bank reactive power value below which they are declared degraded.

NOTE: this parameter is significant only if the parameter **Inductors** (Chap.7.7.8) = "DISABLED".

The default value is "40". The permitted values for the parameter are [5; 10; 15; 20; 25; 30; 35; 40; 45; 50; 55; 60; 65; 70; 75; 80; 85; 90; 95; 100]%. By setting the value "100" the threshold is disabled.

7.7.10 Breakage thr.1

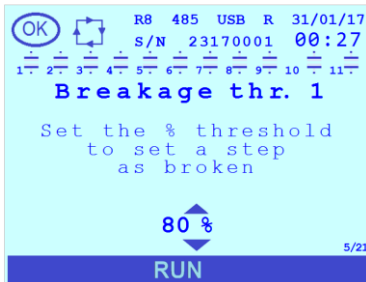

The **Breakage thr.1** parameter defines the percentage decrement of the bank reactive power value below which they are declared faulty and cannot be used for the power factor correction.

NOTE: this parameter is significant only if the parameter **Inductors** (Chap.7.7.8) = "DISABLED".

The default value is "80". The permitted values for the parameter are [5; 10; 15; 20; 25; 30; 35; 40; 45; 50; 55; 60; 65; 70; 75; 80; 85; 90; 95; 100]%. By setting the value "100" the threshold is disabled.

7.7.11 Degr. thres. 2

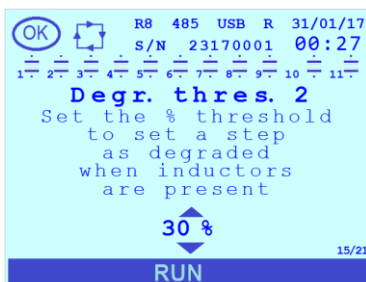

The **Degr. thres. 2** parameter defines the percentage decrement of the bank reactive power value below which they are declared degraded.

NOTE: this parameter is significant only if the parameter **Inductors** (Chap.7.7.8) = "ENABLED".

The default value is "30". The permitted values for the parameter are [5; 10; 15; 20; 25; 30; 35; 40; 45; 50; 55; 60; 65; 70; 75; 80; 85; 90; 95; 100]%. By setting the value "100" the threshold is disabled.

7.7.12 Breakage thr.2

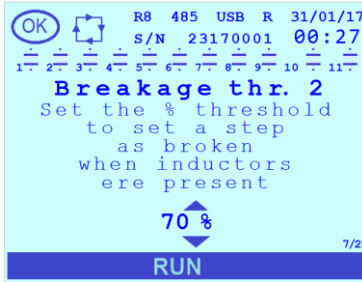

The **Breakage thr.2** parameter defines the percentage decrement of the bank reactive power value below which they are declared faulty and cannot be used for the power factor correction.

NOTE: this parameter is significant only if the parameter **Inductors** (Chap.7.7.8) = "ENABLED".

The default value is "70". The permitted values for the parameter are [5; 10; 15; 20; 25; 30; 35; 40; 45; 50; 55; 60; 65; 70; 75; 80; 85; 90; 95; 100]%. By setting the value "100" the threshold is disabled.

7.7.13 Current alarm reset (Alarm reset)



The parameter allows enabling / disabling the alarm reset by pressing the key  in the relevant alarm detail page of the **Alarms state Menu** (Chap.8.7.1); the alarms in the following list can be reset: **Overvoltage**, **Overcurrent**, **Low voltage**, **Low current**, **High THDV%**, **High THDI%**, **High temperature**, **Overcompensation**, and **Undercompensation**. The **Voltage dip** alarm will reset automatically after a time equal to the **Connection time** (Chap. 7.3.3). The **Cn bank breakage (n=1÷11)** alarms can be reset through the **Reset Menu** (Chap. 8.8). For further information refer to chapter **Alarm display and management** (Chap. 8.7).

If the parameter is set to "DISABLED" it will not be possible to reset the alarms in progress by pressing the key  in the **Alarms state Menu** (Chap.8.7.1).

The default value is "ENABLED". The permitted values for the parameter are [DISABLED; ENABLED].

7.7.14 Measurement display from harmonic Analysis (Harmonic analys.)

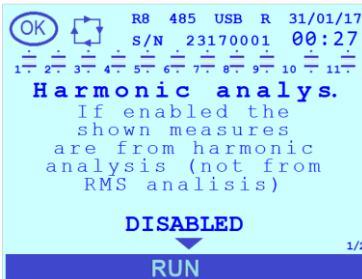

By setting the **Harmonic analys.** parameter to "ENABLED" the voltage, current, active power, reactive power and apparent power measurements displayed and sent via communication interfaces will be those concerning the sole component at the fundamental frequency (the measurement units will be marked with "dff" suffix). The RMS values will be displayed by setting the parameter to "DISABLED" for the previous measurements.

The default value is "DISABLED". The permitted values for the parameter are [DISABLED; ENABLED].

7.7.15 Auto-acquisition power threshold (Autodiagn.thres.)

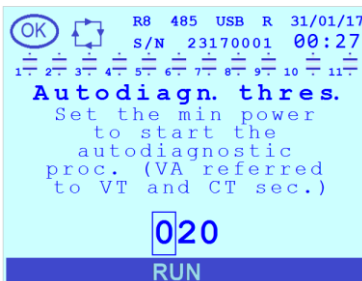

The **Autodiagn.thres.** parameter defines the active and reactive power value (as measured at the CT and VT secondary windings) under which the measurements are considered equal to zero during the auto-acquisition procedure of the capacitor banks.

The default value is "20". The permitted range for the parameter is [0÷200] W / VAR.

7.7.16 868MHz address



NOTE: the parameter is not to be mistaken with the address used for the RS485 communication defined through the **Address** parameter present in the Setup Menu|Communication ([Chap. 7.4.2](#)).

The default value is "31". The permitted range for the parameter is [1÷247].

7.7.17 868MHz channel

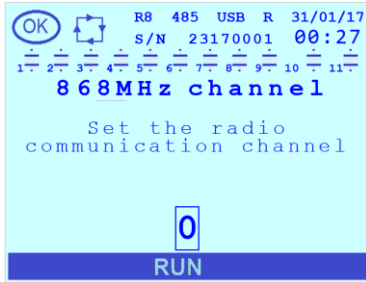

The **868MHz channel** parameter describes the specific frequency band on which the controller will tune for the 868MHz Radio communication. There are 6 adjacent radio channels available with band width equal to 100KHz in the frequency range [868.0;868.6] MHz

The default value is "0". The permitted range for the parameter is [0÷5].

7.7.18 Network type

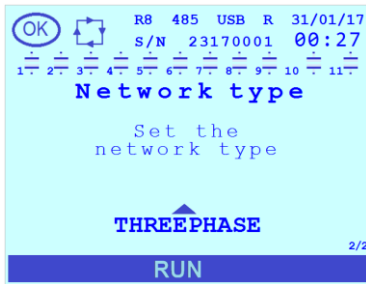

The default value is "THREEPHASE". The permitted values for the parameter are [SINGLEPHASE; THREEPHASE].

If the controller is connected to a three-phase network set the **Network type** = "THREEPHASE" while if it is connected to a single-phase network set it to "SINGLEPHASE":

7.7.19 Voltage dip duration (Voltage dip)

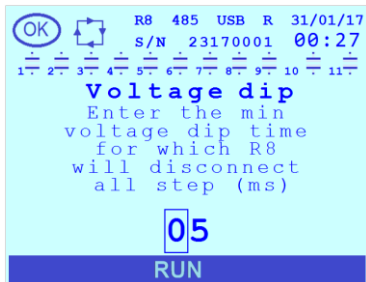

The **Voltage dip** parameter defines the minimum duration (in ms) for which a permanence of the voltmetric input below 10% of the VT secondary winding is acknowledged by the controller as a voltage dip alarm activation condition and triggers the relevant countermeasures described in **Voltage dip alarm** ([Chap.8.7.2.11](#)).

The default value is "5". The permitted range for the parameter is [5÷40]ms.

7.7.20 Step connection maximum duration (Tmax step)



The **Tmax step** parameter defines the maximum continuous connection duration of a capacitor bank in presence of other available banks with equal rated power. When the set time is over, the bank will be forcedly disconnected and replaced with one equivalent. By doing that, a rotation will be carried out able to equalise the duration over time of the banks with equal rated power in presence of slightly variable loads.

The default value is "8". The permitted range for the parameter is [0÷999] hours. By setting the value "0" the functionality is disabled and no rotation will be carried out.

7.7.21 THDI invalidation threshold (Imax harmonic)

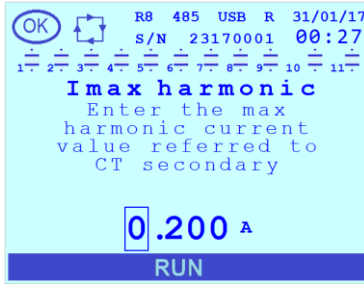

The **Imax harmonic** parameter defines the harmonic current threshold (expressed in A) measured at the CT secondary winding below which the THDI% measurement value is invalidated ("---" will be displayed). Set this parameter to a value that is considered not harmful for the equipment as, by invalidating the THDI%, the relevant alarm is disabled (regardless from how it was set through parameters **THDI alarm threshold** (Chap.7.5.11) and **THDI alarm delay** (Chap.7.5.12)).

The default value is "0.20". The permitted range for the parameter is [0.03÷5] A.

7.7.22 Alarm masking management (Alarm mask)



The **Alarm mask** parameter allows managing any signal masking of all alarms (excluding the **low voltage alarm** (Chap.8.7.2.3)) based on specific operating conditions.

The default value is "NONE". The permitted values for the parameter are ["NONE"; "INVALID COSFI"; "COSFI OK W/O STEPS"; "BOTH"].

- By setting the value "NONE" (default) no masking is activated.
- If the value "INVALID COSFI" is set, masking will be active if the **cosfi** measurement is invalid ("---" will be displayed).
- If the "COSFI OK W/O STEPS" value is set, masking will be active if the **cosfi** falls within the band defined by parameters **Target cosfi** (Chap. 7.2.1), (or **Cosfi time band 2**, **Cosfi time band 3** or **Cosfi TB4/GEN** according to current time band and the operating mode set in case of system in generation, refer to (Chap. 7.2) and (Chap.7.3) and **Cosfi tolerance** (Chap. 7.2.2) and if no capacitor bank has been inserted.
- If "BOTH" value is set, masking will be active if one of the conditions indicated for the two previous values occurs.

In case of active masking (excluding the **low voltage alarm** for which masking has no effect):

- the alarms that will activate will be temporarily signalled for 3 seconds through a pop-up window;
- any relay output associated to the alarm will not be activated and the alarm presence symbol will not be displayed at the top left side of the status bar;
- The alarm will be anyway active in the **Alarms state Menu** (Chap.8.7.1);
- the disconnection of the power factor correction banks (for the alarms that feature this option) is in any case performed within the times and modes provided for by the single alarm.

7.7.23 Log first meas.



The **Log first meas.** parameter is a value corresponding to the identification number of the first measurement to be saved in the internal event log of the controller (at the end of each **Log period** (Chap.7.7.25)).

NOTE: the management of the event log dedicated to the log measurements is of the FIFO type, at the end of the available space (approx. 42,000 records for each measurement) the oldest records will be overwritten.

The default value is "360" (corresponding to the average equivalent three-phase cosfi). The possible values are the addresses of the Modbus map that can be consulted in the document "Modbus-RTU Communication Protocol" available at the following link: <https://www.ducatienergia.com/product.php?lang=en&id=8&cat=13&product=91>



7.7.24 Log second meas.

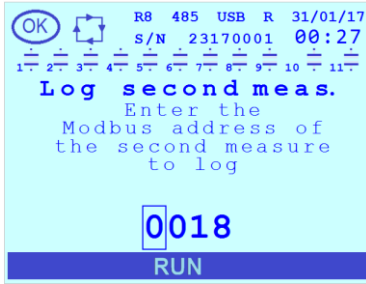

The **Log second meas.** is a value corresponding to the identification number of the second measurement to be saved in the internal event log of the controller (at the end of each **Log period** [Chap.7.7.25](#)).

The default value is "36" (average equivalent three-phase active power). The possible values are the addresses of the Modbus map that can be consulted in the Modbus Protocol document "Modbus-RTU Communication Protocol" available at the following link: <https://www.ducatienergia.com/product.php?lang=en&id=8&cat=13&product=91>

7.7.25 Log period

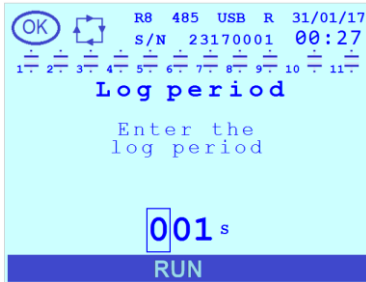

The **Log period** parameter is the time value (expressed in seconds) between two consequent saving operations in the event log of the two log measurements set by the user and previously described in [Chap.7.7.23](#) and [Chap. 7.7.24](#).

The default value is "900". The permitted range for the parameter is [1÷999] s.

NOTE: the management of the event log dedicated to the log measurements is of the FIFO type, at the end of the available space (approx. 42,000 records for each one of the two measurements) the oldest records will be overwritten. Refer to [Chap.8.5](#) relevant to the Events Menu for more information.

7.7.26 Enable log

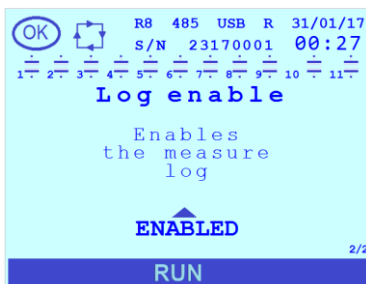

The **Enable log** parameter allows enabling or disabling the saving of the log (1 and 2) measurement values set by the user ([Chap.7.7.23](#) and [Chap. 7.7.24](#)). NOTE: the parameter acts on both log measurements at the same time.

The default value is "ENABLED". The permitted values for the parameter are [DISABLED; ENABLED].

NOTE: the management of the event log dedicated to the log measurements is of the FIFO type, at the end of the available space (approx. 42,000 records for each one of the two measurements) the oldest records will be overwritten. Refer to [Chap. 8.5](#) relevant to the Events Menu for more information.

GO BACK TO [SETTINGS](#)

GO BACK TO [CONTENTS](#)



7.8 Parameter range and default values

Parameter	UM	Min. value	Max. value	Default	Details
CT primary	A	5	10000	5	Chap. 7.1.1
CT secondary	A	1	5	5	Chap. 7.1.2
CT phase	-	L1(R)/L2(S)/L3(T)		L1(R)	Chap. 7.1.3
CT inversion	-	DISABLED/ENABLED		DISABLED	Chap. 7.1.4
Cogeneration	-	DISABLED/ENABLED		DISABLED	Chap. 7.1.5
Frequency	Hz	50Hz/60Hz/AUTO		AUTO	Chap. 7.1.6
VT primary	V	50	200000	400	Chap. 7.1.7
VT secondary	V	50	525	400	Chap. 7.1.8
Voltage phase	-	L1n/L2n/L3n/L12/L23/L31		L23	Chap. 7.1.9
Phase offset	°	-180	180	0	Chap. 7.1.10
Target cosfi	-	0.500 CAP	0.500 IND	0.980 IND	Chap. 7.2.1
Cosfi tolerance	-	0.010	0.100	0.030	Chap. 7.2.2
Cosfi time band 2	-	0.500 CAP	0.500 IND	0.980 IND	Chap. 7.2.3
Cosfi time band 3	-	0.500 CAP	0.500 IND	0.980 IND	Chap. 7.2.4
Cosfi TB4/GEN	-	0.500 CAP	0.500 IND	0.980 IND	Chap. 7.2.5
Band B1	hh:mm:ss	00:00:00	23:59:00	00:00:00	Chap. 7.2.6
Band B2	hh:mm:ss	00:00:00	23:59:00	99:99:00 (OFF)	Chap. 7.2.7
Band B3	hh:mm:ss	00:00:00	23:59:00	99:99:00 (OFF)	Chap. 7.2.8
Band B4	hh:mm:ss	00:00:00	23:59:00	99:99:00 (OFF)	Chap. 7.2.9
Avg. integrat. time	min	1	60	15	Chap. 7.2.10
Step voltage	V	50	5000	400	Chap. 7.3.1
Manual mode	-	DISABLED/ENABLED		DISABLED	Chap. 7.3.2
Connection time	s	1	60	60	Chap. 7.3.3
Discharge time	s	1	60	60	Chap. 7.3.4
Step disconnection	-	DISABLED/ENABLED		DISABLED	Chap. 7.3.5
Step n function (n=1÷11)	-	1. STEP 2. ALWAYS ON STEP 3. ALWAYS OFF STEP 4. N.O. CONTACT ALARM 5. N.C. CONTACT ALARM 6. FAN OUTPUT 7. MAN / AUT OUTPUT 8. R8 RUNNING (RUN)		STEP	Chap. 7.3.6.1
Step Cn power (n=1÷11)	kVAr	0	9999,9	0	Chap. 7.3.6.2
Alarm output n (n=1÷11)	-	1. OVERVOLTAGE 2. OVERCURRENT 3. LOW VOLTAGE 4. LOW CURRENT 5. OVERCOMPENSATION 6. UNDERCOMPENSATION 7. HIGH TEMPERATURE 8. HIGH THDV% 9. HIGH THDI% 10. GENERIC		OVER VOLTAGE	Chap. 7.3.6.3
Manual status Cn (n=1÷11)	-	OFF/ON		OFF	Chap. 7.3.6.4
Protocol	-	MODBUS/ASCII DUCBUS		MODBUS	Chap. 7.4.1
Address	-	1 (MODBUS) 1 (DUCBUS)	247 (MODBUS) 98 (DUCBUS)	31	Chap. 7.4.2
Baudrate	bps	9600 / 19200 / 38400 / 57600 / 115200		9600	Chap. 7.4.3
NFC information	-	read-only parameter		-	Chap. 7.4.4
HV Alarm Thres.	V	80% VT Primary	110% VT Primary	110% VT Primary	Chap. 7.5.1
HV Alarm Delay	s	1	255	10	Chap. 7.5.2
HI Alarm Thres.	A	90% CT Primary	120% CT Primary	120% CT Primary	Chap. 7.5.3



HI Alarm Delay	s	1	255	10	Chap. 7.5.4
LV Alarm Thres.	V	80% VT Primary	110% VT Primary	OFF	Chap. 7.5.5
LV Alarm Delay	s	1	255	10	Chap. 7.5.6
LI Alarm Thres.	A	0.7% CT Primary	10% CT Primary	0.7% CT Primary	Chap. 7.5.7
LI Alarm Delay	s	1	255	10	Chap. 7.5.8
THDV% Alarm Thres.	%	1	100	999 (OFF)	Chap. 7.5.9
THDV% Alarm Delay	s	1	255	10	Chap. 7.5.10
THDI% Alarm Thres.	%	1	100	999 (OFF)	Chap. 7.5.11
THDI% Alarm Delay	s	1	255	10	Chap. 7.5.12
Hcosfi Alarm Delay	min	1	255	60	Chap. 7.5.13
Lcosfi Alarm Delay	min	1	255	60	Chap. 7.5.14
Temp. Alarm	°C (°F)	0 (32)	80 (176)	60 (140)	Chap. 7.5.15
Temp. Alarm Delay	s	1	255	10	Chap. 7.5.16
Fan A. Thres.	°C (°F)	0 (32)	80 (176)	35 (95)	Chap. 7.5.17
Fan A. Delay	s	1	255	10	Chap. 7.5.18
Language	-	ENGLISH / ITALIANO / FRANÇAIS / ESPAÑOL/ DEUTSCH / PORTUGUÊS / 中文		ENGLISH	Chap. 7.6.1
Temperature unit	-	°CELSIUS / °FAHRENHEIT		° CELSIUS	Chap. 7.6.2
Enable password	-	DISABLED/ENABLED		DISABLED	Chap. 7.6.3
Password	-	0000	9999	0000	Chap. 7.6.4
Firmware rel.	-	read-only parameter		-	Chap. 7.6.5
Bootloader rel.	-	read-only parameter		-	Chap. 7.6.6
Language rel.	-	read-only parameter		-	Chap. 7.6.7
Backlight	-	OFF/ON		ON	Chap. 7.6.8
Backlight auto	-	DISABLED/ENABLED		DISABLED	Chap. 7.6.9
Contrast	-	0	10	4	Chap. 7.6.10
Date	gg/mm/aa	01/01/1970	31/12/2099	01/01/2017	Chap. 7.6.11
Time	hh:mm:ss	00:00:00	23:59:59	00:00:00	Chap. 7.6.12
Summertime	-	STANDARD TIME / D.L. SAVING TIME		STANDARD TIME	Chap. 7.6.13
Connection time (Connection time differentiation)	-	DISABLED/ENABLED		DISABLED	Chap. 7.7.1
Tdis (Connection time in disconnection)	s	1	30000	60	Chap. 7.7.2
Teval (Evaluation time)	network cycles	10	1500	275	Chap.7.7.3
Ttr dis (Transient time in disconnection)	network cycles	5	250	10	Chap. 7.7.4
Ttr ins (Transient time in insertion)	network cycles	5	250	10	Chap. 7.7.5
Sliding win.avg. (Measurement stability check)	-	DISABLED/ENABLED		DISABLED	Chap. 7.7.6
%Slid.win. avg. (Measurement stability check threshold)	%	1	50	20	Chap. 7.7.7
Inductors (Inductors presence)	-	DISABLED/ENABLED		DISABLED	Chap. 7.7.8
Degr. Thres. 1	%	5/10/15/20/25/30/35/40/45/50/ 55/60/65/70/75/80/85/90/95/100		40	Chap. 7.7.9
Breakage Thr.1	%	5/10/15/20/25/30/35/40/45/50/ 55/60/65/70/75/80/85/90/95/100		80	Chap. 7.7.10
Degr. Thres. 2	%	5/10/15/20/25/30/35/40/45/50/ 55/60/65/70/75/80/85/90/95/100		30	Chap. 7.7.11
Breakage Thr.2	%	5/10/15/20/25/30/35/40/45/50/ 55/60/65/70/75/80/85/90/95/100		70	Chap. 7.7.12
Alarm treset	-	DISABLED/ENABLED		ENABLED	Chap. 7.7.13
Harmonic analys. (Displaying of measurements from harmonic	-	DISABLED/ENABLED		DISABLED	Chap. 7.7.14



analysis)					
Autodiagn.thres. (Power threshold for auto-acquisition)	VA (on CT and VT secondary windings)	0	200	20	Chap. 7.7.15
868MHz address	-	1	247	31	Chap. 7.7.16
868MHz channel	-	0	5	0	Chap. 7.7.17
Network type	-	SINGLEPHASE/THREEPHASE		THREEPHASE	Chap. 7.7.18
Voltage dip (Voltage dip duration)	msec	5	40	5	Chap. 7.7.19
Tmax step (Step maximum connection time)	ore	0	999	8	Chap. 7.7.20
Imax harmonic (THDI invalidation threshold)	A (on CT secondary winding)	0.001	5.000	0.200	Chap. 7.7.21
Alarm mask (Alarm masking management)	-	NONE / INVALID COSFI / COSFI OK W/O STEPS / BOTH		NONE	Chap. 7.7.22
Log first meas.		Refer to the Modbus manual available here below: https://www.ducatienergia.com/product.php?lang=en&id=8&cat=13&product=91		360 (threephase avg. cosfi)	Chap. 7.7.23
Log second meas.		Refer to the Modbus manual available here below: https://www.ducatienergia.com/product.php?lang=en&id=8&cat=13&product=91		36 (threephase avg. active power)	Chap. 7.7.24
Log period	s	1	999	900	Chap. 7.7.25
Enable log		DISABLED/ENABLED		ENABLED	Chap. 7.7.26

GO BACK TO [SETTINGS](#)

GO BACK TO [CONTENTS](#)

7.9 Entering modes for parameter values

There are two possible entering modes for parameter values:

- entering a numerical value one digit at a time within a set range;
- selection of a value between those available in set list.

1.) ↘



In case 1, upon accessing the parameter setting page, the previously set numerical value will be shown with the digit more on the left highlighted with a box:

- press the keys or to increase or decrease the selected digit;
- to change the other digits move in a circular manner from left to right and press the key .

NOTE: the grouping of more digits inside the box, the non-contiguity of the digits or the presence of decimal separators, bars or other separators does not change the previous two rules that remain valid.

The change in progress can be cancelled by pressing key .

To confirm the parameter value, press key .

WARNING: by confirming the parameter, the value will overwrite the previous one.

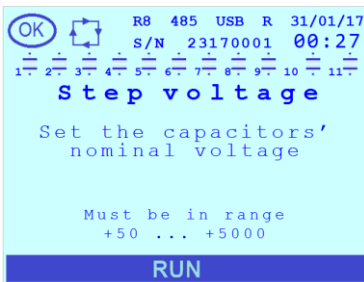

If a value outside the permitted range for the parameter is added, an information message containing the permitted value range will be displayed.

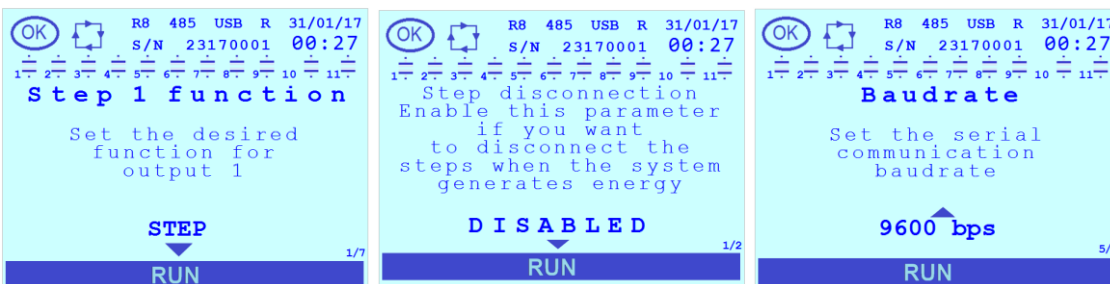

Press the key to quit the page and go back to the previous menu.

2.) ↘



In case 2, upon accessing the parameter setting page, the value previously set will be shown as well as up and/or down arrows indicating the possibility to scroll a list and, at the bottom right side, a counter indicating the position of the current value in the pre-defined list:



The pre-defined parameter list can be scrolled by pressing the keys  or  until the requested value is displayed.

To cancel the change in progress, quit the page and go back to the previous menu press key .

To confirm the parameter value, press key .

WARNING: by confirming the parameter, the value will overwrite the previous one.

Press the key  to quit the page and go back to the previous menu.

3.) ↘

Both for case 1 and for case 2 it is possible that the parameter is in read-only mode. Under these circumstances:

- in case 1 no digit will be highlighted with the box;
- in case 2 the arrows indicating the possibility to scroll the list will not be displayed.

GO BACK TO [SETTINGS](#)

GO BACK TO [CONTENTS](#)



8 USING THE CONTROLLER

- GO TO [Chap. 8.1 - Regulator informations](#)
- GO TO [Chap. 8.2 - Display and key description](#)
- GO TO [Chap. 8.3 - Measures menu](#)
- GO TO [Chap. 8.4 - Graphics menu](#)
- GO TO [Chap. 8.5 - Events menu](#)
- GO TO [Chap. 8.6 - Statistics menu](#)
- GO TO [Chap. 8.7 - Alarms and fan management and display](#)
- GO TO [Chap. 8.8 - Reset menu](#)
- GO TO [Chap. 8.9 - Communication interfaces](#)
- GO TO [Chap. 8.10 - Manual power factor correction mode](#)
- GO TO [Chap. 8.11 - Presence of blocking reactors](#)
- GO TO [Chap. 8.12 - Firmware, Bootloader and Language update](#)
- GO BACK TO [CONTENTS](#)

8.1 Regulator informations

8.1.1 Model and Serial Number

The information relating to model (with relevant Part Number) and Serial Number of the R8 Controller can be inferred from the silver plate affixed on enclosure right side.

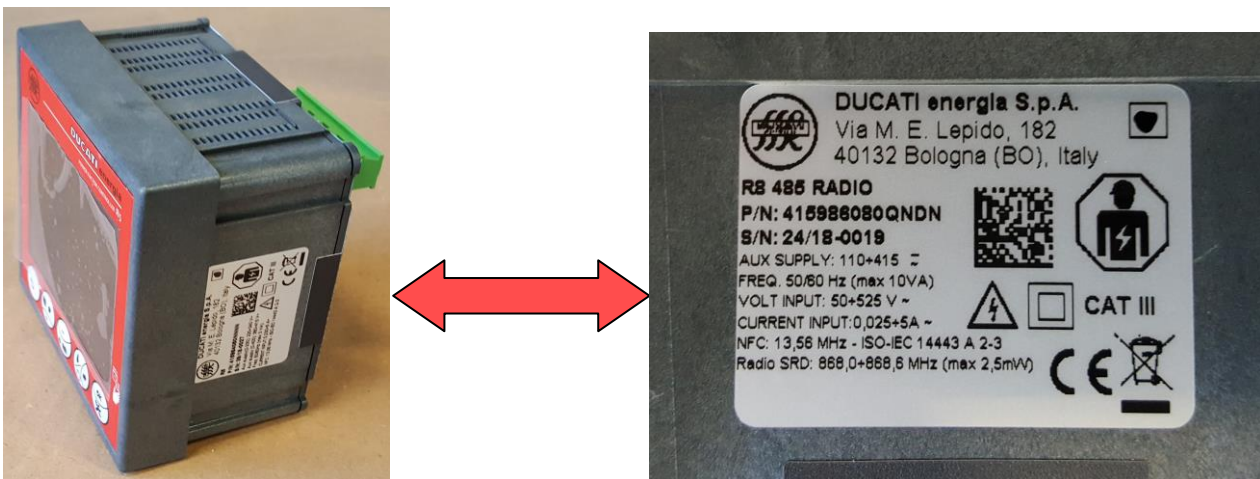

The same information can be also inferred from the RS485 and Radio 868MHz communication interfaces and through the Ducati Smart Energy App. For further information, refer to [Chap. 8.9 - Communication interfaces](#).

8.1.2 Firmware, Bootloader and Language release version

The informations on the firmware, bootloader and language release versions are available in the [System Setup Menu](#). For further details see [Chap. 7.6](#).

It is possible to update each one through the NFC interface and (if available) through the RS485, 868MHz Radio, Bluetooth, USB and Ethernet interfaces. For further details, refer to [Chap. 8.12](#).

- GO BACK TO [USING THE CONTROLLER](#)
- GO BACK TO [CONTENTS](#)



8.2 Display and key description

8.2.1 Display

The display includes both icons and alphanumeric fields.

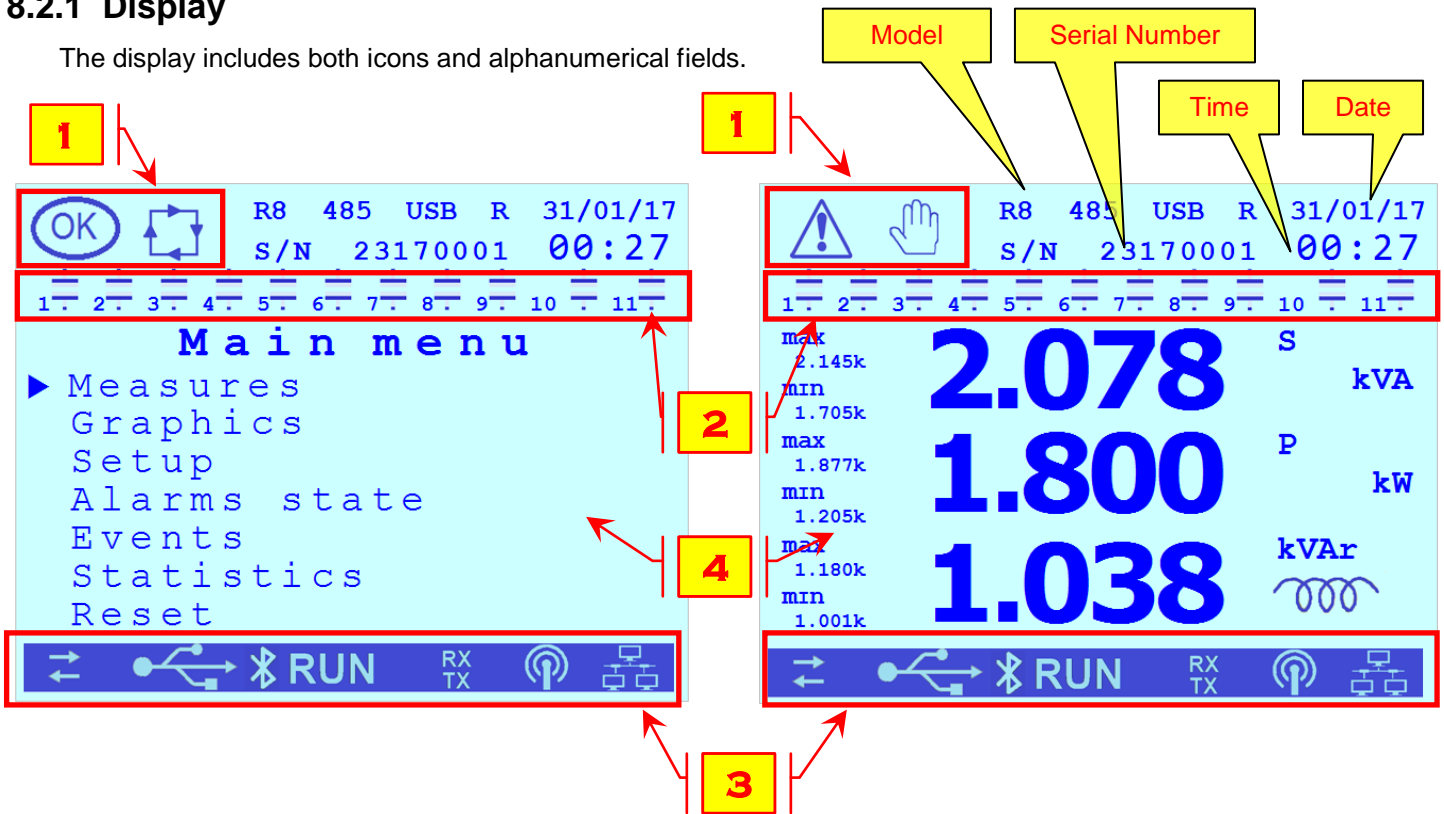

The following tables list them with the relevant meanings:

1		
Icon	Description	Notes
	ALARM STATUS	As an alternative
	OK STATUS	
	MANUAL MODE	As an alternative
	MANUAL MODE WAITING FOR TECHNICAL TIME TO RUN OUT	
	AUTOMATIC MODE	
	AUTOMATIC MODE WAITING FOR TECHNICAL TIME TO RUN OUT	

2	
Icon	Description
	AVAILABLE CAPACITOR NOT INSERTED
	CAPACITOR INSERTED/ INSERTED IN A FIXED MANNER
	CAPACITOR NOT PRESENT / NOT INSERTED IN A FIXED MANNER
	BROKEN CAPACITOR
ON OFF	ACTIVE
	NOT ACTIVE
	ACTIVE (rotating)
	NOT ACTIVE (still)

CAPACITOR OUTPUT
(As an alternative)

ALARM OUTPUT
(As an alternative)

DRIVE OUTPUT FAN
(As an alternative)

3	
Icon	Description
	COGENERATION MODE ACTIVE
RUN	CONTROLLER OPERATION INDICATOR (If flashing)
	USB CONNECTION ACTIVE (If flashing, data exchange in progress)
	BLUETOOTH CONNECTION ACTIVE (If flashing, data exchange in progress)
RX TX	SERIAL COMMUNICATION ACTIVE (If flashing, data exchange in progress)
	868 COMMUNICATION ACTIVE (If flashing, data exchange in progress)
	ETH COMMUNICATION ACTIVE (If flashing, data exchange in progress)



8.2.2 Button function

The functions associated to the 5 keys depend on the context in which they are pressed. The following tables describe keys functions in the various menus available on R8 Controller. For untreated menus and for more information refer to the corresponding menu chapters.

BUTTON FUNCTION – MEASURES MENU		
Button	Short press	Long press
	Back to the Main Menu	-
	Next page	-
	Previous page	-
	Min, Max and/or Average values	Enable / Disable Manual PFC Mode
	-	-

BUTTON FUNCTION – MAIN MENU AND MENU LIST (WITH CURSOR ON THE LEFT)		
Button	Short press	Long press
	Back to previous menu level	-
	Previous item	-
	Next item	-
	-	-
	Access to selected item	-

BUTTON FUNCTION – PARAMETER SETTING PAGES		
Button	Short press	Long press
	Cancel current modification / Return to previous menu level	-
	Increment selected digit / Next Value	-
	Decrement selected digit / previous value	-
	Select next digit	-
	Confirm value	-

GO BACK TO [USING THE CONTROLLER](#)

GO BACK TO [CONTENTS](#)



8.3 Measures menu

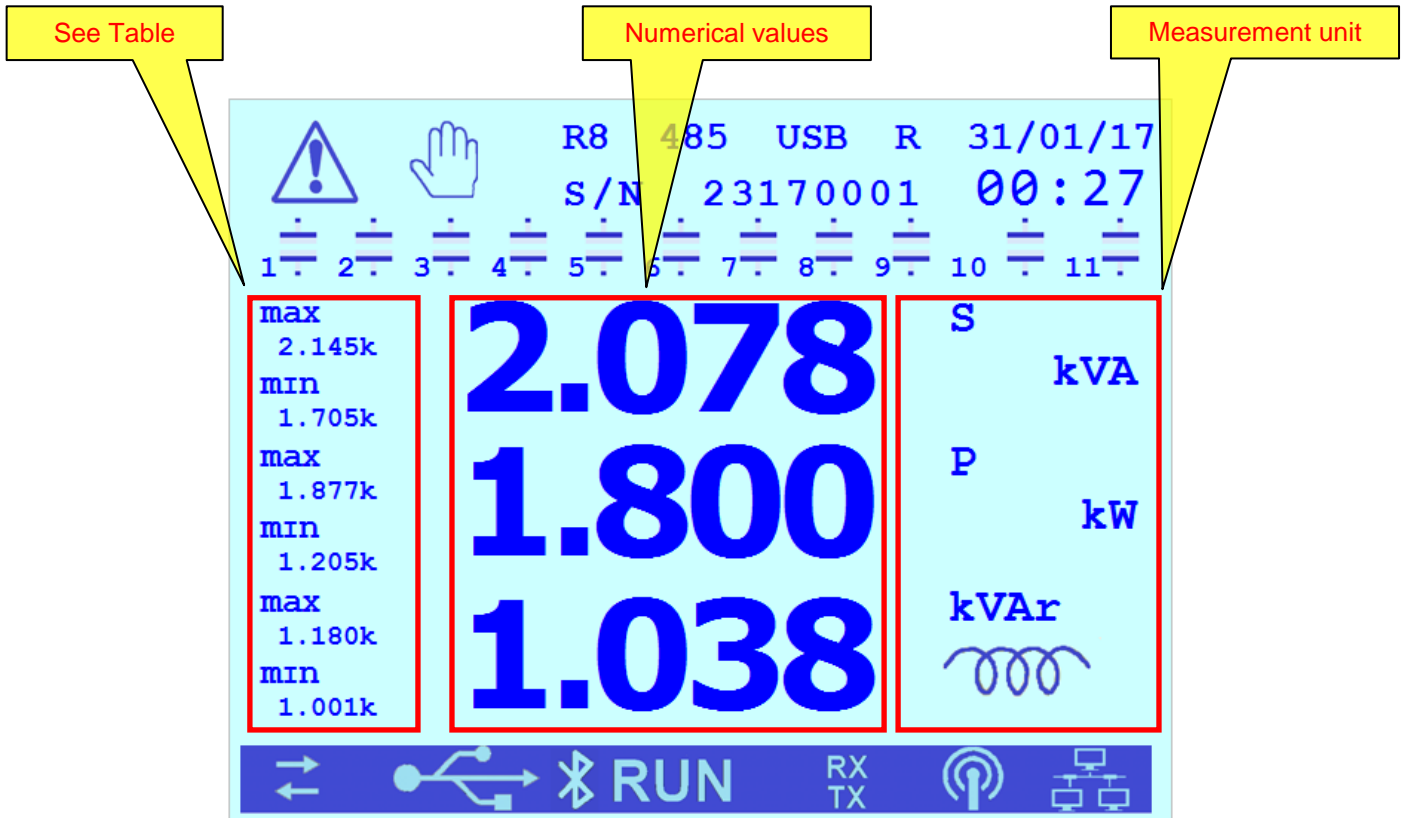

Icon	Description
MONTH	Average monthly value
WEEK	Average weekly value
DAY	Average daily value
AVG	Average value in the average time set
MAX	Average monthly value
MAXAVG	Maximum average value
MIN	Minimum value

Table



8.3.1 dkVAr measure

The dkVAr measure represents the reactive power corresponding to the distance from the target cosfi range defined by parameters **Target cosfi** [Chap.7.2.1](#) (or **Cosfi time band 2**, **Cosfi time band 3** or **Cosfi TB4/GEN** according to current time band and the operating mode set in case of system in generation, refer to [Chap.7.2](#) and [Chap.7.3](#)) and **Cosfi tolerance** [Chap. 7.2.2](#).

In case of capacitive dkVAr, the current value of the cosfi results to be more capacitive with respect to the most capacitive end of the target cosfi range of a quantity corresponding to the indicated reactive power.



In case of inductive dkVAr, the current value of cosfi results to be more inductive than the most inductive end of the target cosfi range of a quantity corresponding to the indicated reactive power.



Within the target cosfi range the dkVAr value will be null.

GO BACK TO [USING THE CONTROLLER](#)

GO BACK TO [CONTENTS](#)

8.4 Graphics menu

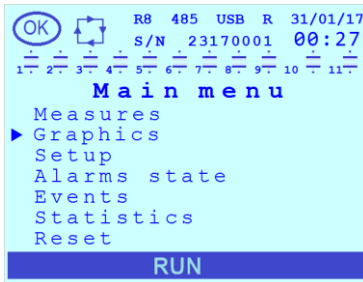

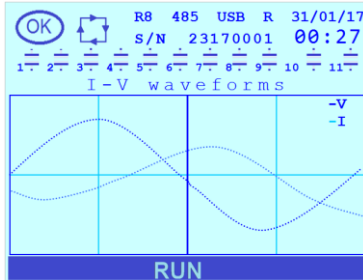

In the Main Menu page, through keys  or , move the cursor on "**Graphics**"

and press key .



The first page displays the voltage and current waveforms in one network period.

Through the keys  or  or  it is possible to scroll the other pages of the Graphics Menu.

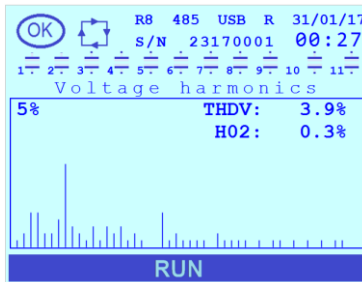
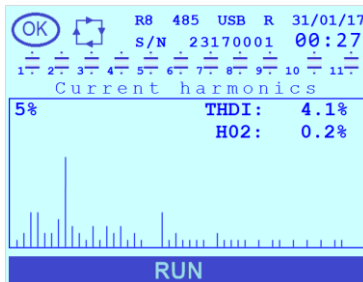

Current and voltage harmonics histogram are available.

Each screen at the top left will show the value of the full scale of the current view.

At the top right there are the value of THDV% (or THDI%) and of the selected harmonic (the default index is 2).

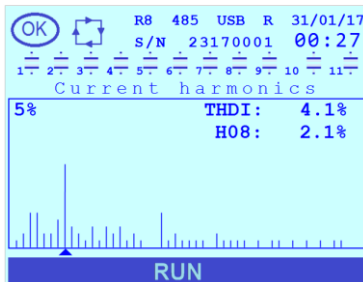

In order to display the value of the harmonic of index n ($n=2\div 60$): press the key  to activate the cursor and move the cursor up to the target harmonic through the keys

 or  or .

Press the key  to exit from the page and return to the previous menu.



GO BACK TO [USING THE CONTROLLER](#)

GO BACK TO [CONTENTS](#)



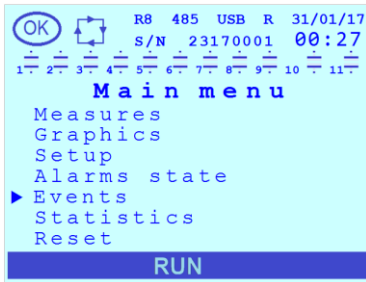

8.5 Events menu



In the Main Menu page, through keys  or , move the cursor on "Events" and press key .







The Events Menu includes the following items: Alarms state, Warnings, System event and Log measures. Each menu item contains further submenus. For details, see the corresponding chapters.

Through keys  or , move the cursor on the desired item and press key  to enter the item submenu.

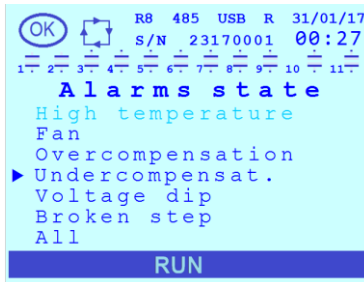
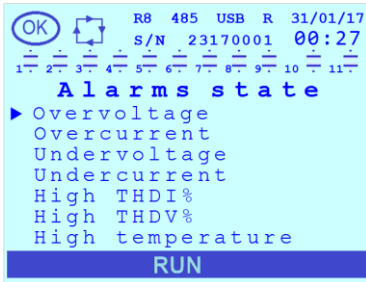
Below you will see examples of the pages related to the Alarms but the same considerations can be applied to all the other item submenus.

Selecting an item and pressing the key  will be displayed the corresponding sublist.





Through keys  or , move the cursor on the desired item and press key  to display the events of the selected alarm type.



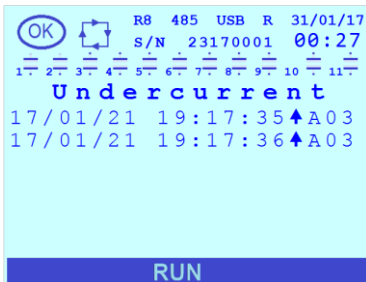

If the archive contains no event related to the selected item, a screen will be displayed with the message "Archive empty".



In case of events presence, during their loading, a screen will be shown with the message "Loading archive please wait".

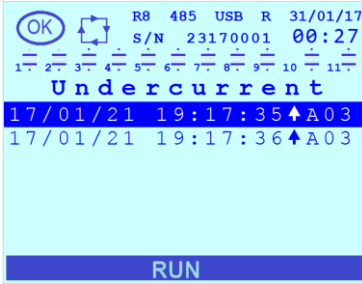



At the end of loading, the list of events will be shown containing for each of them the date, time and some additional information. Use  or  keys to scroll through the list, one page at a time (7 event-records for each page).

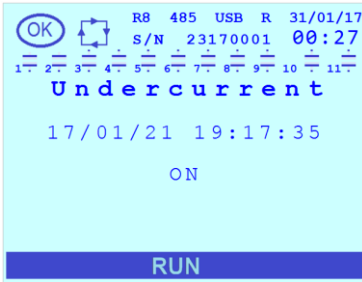

Press the key  to activate the cursor and select the last voice of the current page

By using  or  keys it is possible to move the cursor on the list.



Press the key  to display the detail page of the event

Press the key  to exit from the page and return to the previous menu.

GO BACK TO [USING THE CONTROLLER](#)

GO BACK TO [CONTENTS](#)

8.6 Statistics menu

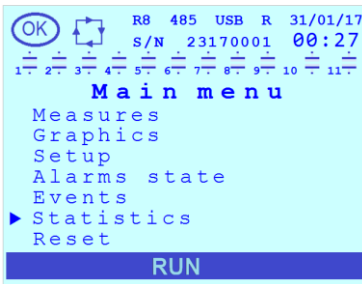

In the Main Menu page, through keys or , move the cursor on "**Statistics**"

and press key .

The statistics related to **Working time**, **Contactor operations**, **Insertions**, **Real power** and **Step status** of each step will be displayed.

NOTE: for Alarms statistics see [Chap. 8.7](#).

Press the key to scroll the parameters listed above. Press the key or to move up or down on the list and to scroll the selected parameter for all the available steps.

Press the key to exit Statistics Menu.

8.6.1 Working time

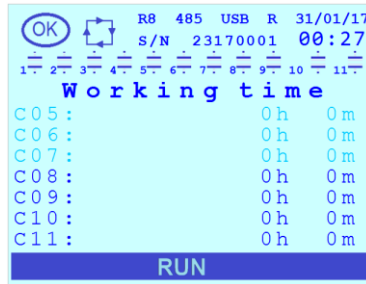
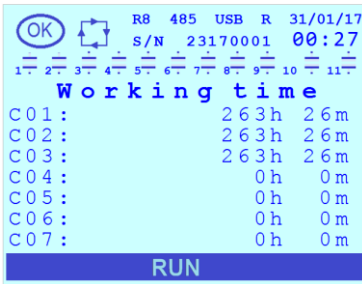

The first parameter displayed is the **Working time** (expressed in hh:mm) of each step Cn (n=1÷11).

8.6.2 Contactor operations

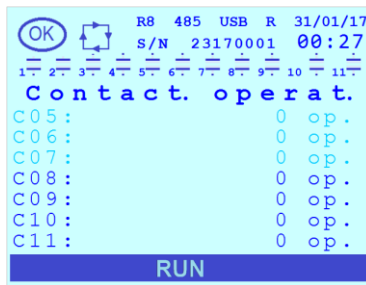
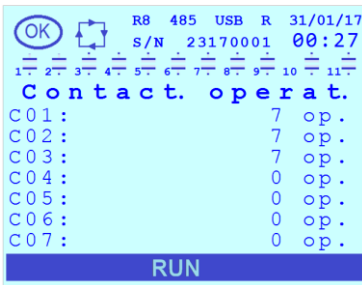

The next parameter is the number of **Contactor operations** of each step Cn (n=1÷11).

8.6.3 Insertions

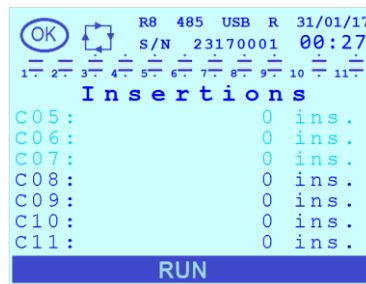
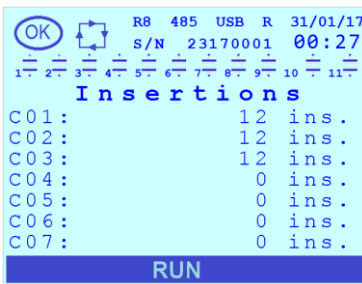

The next parameter is the number of **Insertions** of each step Cn (n=1÷11).



8.6.4 Real power

OK	R8 485 USB R 31/01/17
S/N 23170001 00:27	
1 2 3 4 5 6 7 8 9 10 11	
Real power	
C01:	0.0 kVAr
C02:	0.0 kVAr
C03:	0.0 kVAr
C04:	0.0 kVAr
C05:	0.0 kVAr
C06:	0.0 kVAr
C07:	0.0 kVAr
RUN	

OK	R8 485 USB R 31/01/17
S/N 23170001 00:27	
1 2 3 4 5 6 7 8 9 10 11	
Real power	
C05:	0.0 kVAr
C06:	0.0 kVAr
C07:	0.0 kVAr
C08:	0.0 kVAr
C09:	0.0 kVAr
C10:	0.0 kVAr
C11:	0.0 kVAr
RUN	

The next parameter is the **Real power** of each step (in kVAr). The Real Power is the reactive capacitive power corresponding to the current network voltage and rescaled for the step degradation level estimated by the Power Factor Controller.

8.6.5 Step status

OK	R8 485 USB R 31/01/17
S/N 23170001 00:27	
1 2 3 4 5 6 7 8 9 10 11	
Step status	
C01:	OFF
C02:	OFF
C03:	OFF
C04:	OFF
C05:	OFF
C06:	OFF
C07:	OFF
RUN	

OK	R8 485 USB R 31/01/17
S/N 23170001 00:27	
1 2 3 4 5 6 7 8 9 10 11	
Step status	
C05:	OFF
C06:	OFF
C07:	OFF
C08:	OFF
C09:	OFF
C10:	OFF
C11:	OFF
RUN	

The next parameter is the **Step status** of each step Cn (n=1÷11). This parameter is valid only for the relay output for which the parameter **Step n function (n=1÷11)** is set to one of the following values [STEP; ALWAYS ON STEP; ALWAYS OFF STEP]. Possible values are [ON; OFF; WAIT; BROKEN]. In case of other step function, the value of the Step Status is not relevant and will be set to OFF.

The "WAIT" value indicates that at the moment the step is not-available because of the technical timeout. The "BROKEN" value indicates that the step reactive power estimated by the PFC controller is too low.

GO BACK TO [USING THE CONTROLLER](#)



GO BACK TO [CONTENTS](#)

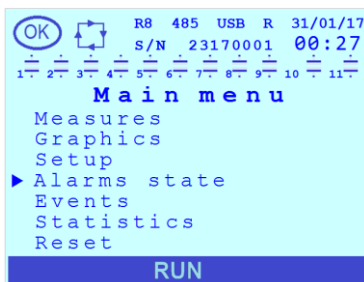

8.7 Alarms and fan management and display

8.7.1 Alarms state menu



In the Main Menu page, through keys  or , move the cursor on "Alarms state" and press key .

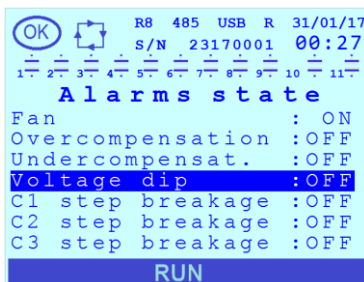
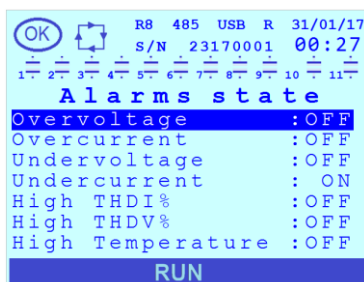

A page with the list of all possible alarms will be displayed as well as the corresponding activation status that can be "ON" or "OFF".



The page features the list of all possible alarms: Overvoltage, Overcurrent, Undervoltage, Undercurrent, High THDI%, High THDV%, High temperature, Fan, Overcompensation, Undercompensat., Voltage dip and Cn step breakage (n=1÷11).

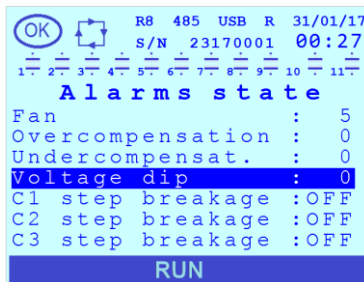
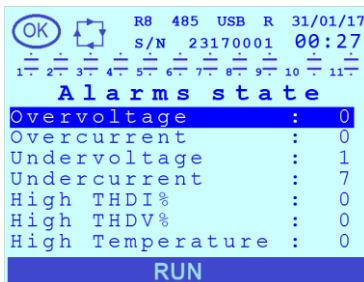

The activation status of the alarm will be displayed next to each alarm ("ON" or "OFF").



Press key  to display the number of occurrences for each alarm instead of the activation status (excluding the alarms Cn step breakage (n=1÷11) for which the activation status will continue to be displayed).



Upon accessing the Alarms state Menu the first element of the list will be selected (Overvoltage). Use keys  or  to move the selection on any element of the list.

Press key  to open a detail page of the selected alarm. Press one of the keys  or  to scroll all detail pages.

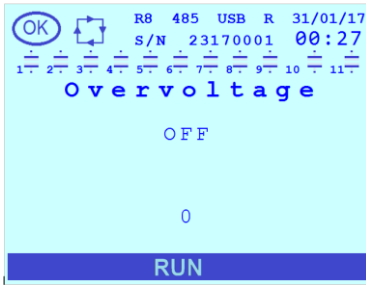

The figures on the side show an example of detail page (**Overvoltage** alarm).

In case the alarm is not active, the following will be present:

- "OFF" status;
- counter of the alarm occurrences.

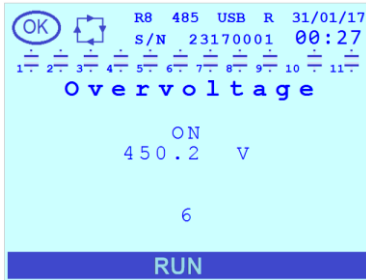

In case the alarm is active, the following will be present:

- "ON" status;
- the measure corresponding to the maximum (or minimum) value of the measurement that generated the alarm condition during current activation;
- counter of the alarm occurrences.

NOTE 1: for alarms **Overcompensation**, **Undercompensation**, **Voltage dip** and **Cn step breakage (n=1÷11)** no corresponding measurement value will be displayed.

NOTE 2: for alarms **Cn step breakage (n=1÷11)** the counter of alarm occurrences will not be provided.

In the detail page of each alarm it is possible to press key  to reset the alarm in progress except for the following alarms:

- **Voltage dip**, that will reset automatically after a time equal to the **Connection time** (Chap. 7.3.3);
- **Cn bank breakage (n=1÷11)**, that can be reset through the **Reset Menu** (Chap. 8.8).

NOTE: The reset function is available only if **Alarm reset** = "ENABLED", see Chap.7.7.13.

To quit the alarm detail pages and the **Alarms state Menu** page press key .

GO BACK TO [USING THE CONTROLLER](#)

GO BACK TO [CONTENTS](#)

8.7.2 Alarms and fan control description

8.7.2.1 Overvoltage alarm

ACTIVATION

The **overvoltage alarm** is activated if the voltage reading of the R8 Controller is above the value defined by parameter **HV Alarm Thres.** (Chap.7.5.1) for a time (in sec) equal to the value of parameter **HV Alarm Delay** (Chap.7.5.2).

MANAGEMENT

The activation of the **overvoltage alarm** triggers the "slow" disconnection of all steps, one at a time, and with a delay between one another equal to **Ttr dis** (Chap.7.7.4). This process takes place in automatic power factor correction mode for all the inserted banks whose **Step n function (n=1÷11)** (Chap. 7.3.6.1) has been set to "STEP" or "ALWAYS ON STEP" and in manual power factor correction mode (refer to Chap. 8.10 - Manual power factor correction mode) for all the steps whose status has been set to "ON".

At the same time, the relay outputs set as "N.O. CONTACT ALARM" or "N.C. CONTACT ALARM" and associated to the "OVERVOLTAGE" or "GENERIC" alarm, will be activated unless, through the **Alarm mask** (Chap.7.7.22) parameter, you decide to mask the alarms under certain operating conditions.

DISPLAYING



Regardless of the current displaying, the alarm will be indicated with a pop-up window lasting 3 seconds and containing the alarm symbol, the name of the alarm that will be activated and its "ON" status. Following:

- the controller will go back to the page displayed before the alarm activation;
- the alarm icon will be displayed in the status bar at the top left side.

The alarm will be anyway active in the **Alarms state Menu** (Chap. 8.7.1).

If you decide to mask the alarms under certain operating conditions, through the **Alarm mask** (Chap.7.7.22) parameter, the previous pop-up window will be displayed but not the alarm icon. The alarm will be anyway active in the **Alarms state Menu**.

STATISTICS

The alarm counter will be increased in the **Alarms state Menu** (Chap. 8.7.1) at every occurrence.

DEACTIVATION

The alarm is automatically deactivated if the voltage reading of the R8 Controller is below the value defined by parameter **HV Alarm Thres.** (Chap. 7.5.1) for a time (in sec) equal to the value of parameter **HV Alarm Delay** (Chap.7.5.2).

RESET

Alarm can be manually reset from the detail page in the **Alarms state Menu** by pressing key  (function possible only if **Alarm reset** = "ENABLED", refer to Chap.7.7.13).

8.7.2.2 Overcurrent alarm

ACTIVATION

The **overcurrent alarm** is activated if the current reading of the R8 Controller is above the value defined by parameter **HI Alarm Thres.** (Chap. 7.5.3) for a time (in sec) equal to the value of parameter **HI Alarm Delay** (Chap.7.5.4).

MANAGEMENT

The activation of the **overcurrent alarm** triggers the "slow" disconnection of all steps, one at a time, and with a delay between one another equal to **Ttr dis** (Chap. 7.7.4). This process takes place in automatic power factor correction mode for all the inserted banks whose **Step n function (n=1÷11)** (Chap. 7.3.6.1) has been set to "STEP" or "ALWAYS ON



STEP” and in manual power factor correction mode (refer to [Chap. 8.10 - Manual power factor correction mode](#)) for all the steps whose status has been set to "ON".

At the same time, the relay outputs set as “N.O. CONTACT ALARM” or “N.C. CONTACT ALARM” and associated to the “OVERCURRENT” or “GENERIC” alarm will be activated unless, through the **Alarm mask** ([Chap.7.7.22](#)) parameter, you decide to mask the alarms in certain operating conditions.

DISPLAYING



Regardless of the current displaying, the alarm will be indicated with a pop-up window lasting 3 seconds and containing the alarm symbol, the name of the alarm that will be activated and its "ON" status. Following:

- the controller will go back to the page displayed before the alarm activation;
- the alarm icon will be displayed in the status bar at the top left side.

The alarm will be anyway active in the Alarms state Menu ([Chap. 8.7.1](#)).

If you decide to mask the alarms under certain operating conditions, through the **Alarm mask** ([Chap.7.7.22](#)) parameter, the previous pop-up window will be displayed but not the alarm icon. The alarm will be anyway active in the Alarms state Menu.

STATISTICS

The alarm counter will be increased in the Alarms state Menu ([Chap. 8.7.1](#)) at every occurrence.

DEACTIVATION

The alarm is automatically deactivated if the current reading of the R8 Controller is below the value defined by parameter **HI Alarm Thres.** ([Chap. 7.5.3](#)) for a time (in sec) equal to the value of parameter **HI Alarm Delay** ([Chap. 7.5.4](#)).

RESET

Alarm can be manually reset from the page inside the Alarms state Menu by pressing key  (function possible only if **Alarm reset** = “ENABLED”, refer to [Chap.7.7.13](#)).

8.7.2.3 Low voltage alarm

ACTIVATION

The **low voltage alarm** is activated if the voltage reading of the R8 Controller is below the value defined by parameter **LV Alarm Thres.** ([Chap. 7.5.5](#)) for a time (in sec) equal to the value of parameter **LV Alarm Delay** ([Chap. 7.5.6](#)).

MANAGEMENT

The activation of the **low voltage alarm** triggers the "slow" disconnection of all steps, one at a time, and with a delay between one another equal to **Ttr dis** ([Chap. 7.7.4](#)). This process takes place in automatic power factor correction mode for all the inserted banks whose **Step n function (n=1÷11)** ([Chap. 7.3.6.1](#)) has been set to “STEP” or “ALWAYS ON STEP” and in manual power factor correction mode (refer to [Chap. 8.10 - Manual power factor correction mode](#)) for all the steps whose status has been set to "ON".

At the same time, the relay outputs set as “N.O. CONTACT ALARM” or “N.C. CONTACT ALARM” and associated to the “LOW VOLTAGE” or “GENERIC”.

DISPLAYING



Regardless of the current displaying, the alarm will be indicated with a pop-up window lasting 3 seconds and containing the alarm symbol, the name of the alarm that will be activated and its "ON" status. Following:

- the controller will go back to the page displayed before the alarm activation;
- the alarm icon will be displayed in the status bar at the top left side.

The alarm will be anyway active in the Alarms state Menu ([Chap. 8.7.1](#)).

The **Alarm mask** ([Chap.7.7.22](#)) parameter has no effect on this alarm.

STATISTICS

The alarm counter will be increased in the Alarms state Menu ([Chap. 8.7.1](#)) at every occurrence.

DEACTIVATION

The alarm is automatically deactivated if the voltage reading of the R8 Controller is above the value defined by parameter **LV Alarm Thres.** ([Chap. 7.5.5](#)) for a time (in sec) equal to the value of parameter **LV Alarm Delay** ([Chap. 7.5.6](#)).

RESET

Alarm can be manually reset from the page inside the Alarms state Menu by pressing key  (function possible only if **Alarm reset** = "ENABLED", refer to [Chap.7.7.13](#)).

8.7.2.4 Low current alarm

ACTIVATION

The **low current alarm** is activated:

- o immediately, if the current reading of the R8 Controller drops below the minimum measurable value equal to 0.7% of parameter **CT primary** ([Chap. 7.1.1](#)) (lower extreme value of the range of parameter **LI Alarm Thres.** ([Chap. 7.5.7](#));
- o after a time (in sec) equal to the parameter **LI Alarm Delay** ([Chap. 7.5.8](#)), if the current reading of the R8 Controller drops below the value defined by parameter **LI Alarm Thres.** ([Chap. 7.5.7](#)).

NOTE: if the measured current is equal to or lower than 0.7% of the **CT primary**, only the immediate activation will take place.

MANAGEMENT

If the activation of the **low current alarm** is triggered by a current value below the minimum measurable value (0.7% **CT primary**) and the regulator is in automatic power factor correction mode, there will be a "slow" disconnection of all inserted banks whose **Step n function (n=1÷11)** ([Chap. 7.3.6.1](#)) has been set to "STEP", one at a time, and with a delay between them equal to **Ttr dis** ([Chap. 7.7.4](#)).

If the activation of the **low current alarm** is triggered by a higher current value (set through parameter **LI Alarm Thres.**) the inserted steps will not be affected in any way.

At the same time, the relay outputs set as "N.O. CONTACT ALARM" or "N.C. CONTACT ALARM" and associated to the "LOW CURRENT" or "GENERIC" alarm will be activated unless, through the **Alarm mask** ([Chap.7.7.22](#)) parameter, you decide to mask the alarms under certain operating conditions.

DISPLAYING

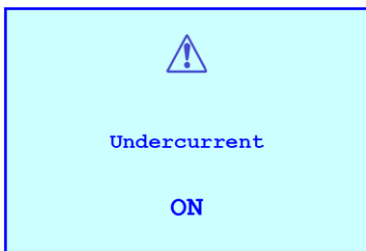

Regardless of the current displaying, the alarm will be indicated with a pop-up window lasting 3 seconds and containing the alarm symbol, the name of the alarm that will be activated and its "ON" status. Following:

- the controller will go back to the page displayed before the alarm activation;
- the alarm icon will be displayed in the status bar at the top left side.

The alarm will be anyway active in the Alarms state Menu ([Chap. 8.7.1](#)).

If you decide to mask the alarms under certain operating conditions, through the **Alarm mask** ([Chap.7.7.22](#)) parameter, the previous pop-up window will be displayed but not the alarm icon. The alarm will be anyway active in the Alarms state Menu.

STATISTICS

The alarm counter will be increased in the Alarms state Menu ([Chap. 8.7.1](#)) at every occurrence.

DEACTIVATION

The alarm is automatically deactivated if the current reading of the R8 Controller is above the value defined by parameter **LI Alarm Thres.** ([Chap. 7.5.7](#)) for a time (in sec) equal to the value of parameter **LI Alarm Delay** ([Chap. 7.5.8](#)).



NOTE: if the activation has been caused by a measured current value equal to or lower than 0.7% of the **CT primary**, as soon as the current value goes above this threshold (and not necessarily above the value defined by parameter **LI Alarm Thres.**) for a time (in sec) equal to the value of parameter **LI Alarm Delay**, the controller will be able to control capacitor bank whose **Step n function (n=1÷11)** has been set to "STEP".

RESET

Alarm can be manually reset from the page inside the Alarms state Menu by pressing key  (function possible only if **Alarm reset** = "ENABLED", refer to **Chap.7.7.13**).

8.7.2.5 THDI alarm

ACTIVATION

The **THDI alarm** is activated if the THDI% value stays above the value defined by parameter **THDI% Alarm Thres.** (**Chap. 7.5.11**) for a time (in sec) equal to the value of parameter **THDI% Alarm Delay** (**Chap. 7.5.12**).

MANAGEMENT

The activation of the **THDI alarm** triggers the "slow" disconnection of all steps, one at a time, and with a delay between one another equal to **Ttr dis** (**Chap. 7.7.4**). This process takes place in automatic power factor correction mode for all the inserted banks whose **Step n function (n=1÷11)** (**Chap. 7.3.6.1**) has been set to "STEP" or "ALWAYS ON STEP" and in manual power factor correction mode (refer to **Chap. 8.10 - Manual power factor correction mode**) for all the steps whose status has been set to "ON".

At the same time, the relay outputs set as "N.O. CONTACT ALARM" or "N.C. CONTACT ALARM" and associated to the "HIGH THDI%" or "GENERIC" alarm will be activated unless, through the **Alarm mask** (**Chap.7.7.22**) parameter, you decide to mask the alarms under certain operating conditions.

DISPLAYING



Regardless of the current displaying, the alarm will be indicated with a pop-up window lasting 3 seconds and containing the alarm symbol, the name of the alarm that will be activated and its "ON" status. Following:

- the controller will go back to the page displayed before the alarm activation;
- the alarm icon will be displayed in the status bar at the top left side.

The alarm will be anyway active in the Alarms state Menu (**Chap. 8.7.1**).

If you decide to mask the alarms under certain operating conditions, through the **Alarm mask** (**Chap.7.7.22**) parameter, the previous pop-up window will be displayed but not the alarm icon. The alarm will be anyway active in the Alarms state Menu

STATISTICS

The alarm counter will be increased in the Alarms state Menu (**Chap. 8.7.1**) at every occurrence.

DEACTIVATION

The alarm is automatically deactivated if the THDI% value stays below the value defined by parameter **THDI% Alarm Thres.** (**Chap. 7.5.11**) for a time (in sec) equal to the value of parameter **THDI% Alarm Delay** (**Chap. 7.5.12**).

RESET

Alarm can be manually reset from the page inside the Alarms state Menu by pressing key  (function possible only if **Alarm reset** = "ENABLED", refer to **Chap.7.7.13**).

8.7.2.6 THDV alarm

ACTIVATION

The **THDV alarm** is activated if the THDV% value stays above the value defined by parameter **THDV% Alarm Thres.** (**Chap. 7.5.9**) for a time (in sec) equal to the value of parameter **THDV% Alarm Delay** (**Chap. 7.5.10**).

MANAGEMENT

The activation of the **THDV alarm** triggers the "slow" disconnection of all steps, one at a time, and with a delay between one another equal to **Ttr dis** (Chap.7.7.5). This process takes place in automatic power factor correction mode for all the inserted banks whose **Step n function (n=1÷11)** (Chap. 7.3.6.1) has been set to "STEP" or "ALWAYS ON STEP" and in manual power factor correction mode (refer to Chap. 8.10 - Manual power factor correction mode) for all the steps whose status has been set to "ON".

At the same time, the relay outputs set as "N.O. CONTACT ALARM" or "N.C. CONTACT ALARM" and associated to the "HIGH THDV%" or "GENERIC" alarm will be activated unless, through the **Alarm mask** (Chap.7.7.22) parameter, you decide to mask the alarms under certain operating conditions.

DISPLAYING



Regardless of the current displaying, the alarm will be indicated with a pop-up window lasting 3 seconds and containing the alarm symbol, the name of the alarm that will be activated and its "ON" status. Following:

- the controller will go back to the page displayed before the alarm activation;
- the alarm icon will be displayed in the status bar at the top left side.

The alarm will be anyway active in the Alarms state Menu (Chap. 8.7.1);

If you decide to mask the alarms under certain operating conditions, through the **Alarm mask** (Chap.7.7.22) parameter, the previous pop-up window will be displayed but not the alarm icon. The alarm will be anyway active in the Alarms state Menu.

STATISTICS

The alarm counter will be increased in the Alarms state Menu (Chap. 8.7.1) at every occurrence.

DEACTIVATION

The alarm is automatically deactivated if the THDV% value stays below the value defined by parameter **THDV% Alarm Thres.** (Chap. 7.5.9) for a time (in sec) equal to the value of parameter **THDV% Alarm Delay** (Chap. 7.5.10).

RESET

Alarm can be manually reset from the page inside the Alarms state Menu by pressing key  (function possible only if **Alarm reset** = "ENABLED", refer to Chap.7.7.13).

8.7.2.7 Temperature alarm

ACTIVATION

The **temperature alarm** is activated if the temperature value read by the R8 Controller stays above the value defined by parameter **Temp. Alarm** (Chap.7.5.15) for a time (in sec) equal to the value of parameter **Temp. Alarm Delay** (Chap. 7.5.16).

MANAGEMENT

The activation of the **temperature alarm** triggers the "slow" disconnection of all steps, one at a time, and with a delay between one another equal to **Ttr dis** (Chap.7.7.4). This process takes place in automatic power factor correction mode for all the inserted banks whose **Step n function (n=1÷11)** (Chap. 7.3.6.1) has been set to "STEP" or "ALWAYS ON STEP" and in manual power factor correction mode (refer to Chap. 8.10 - Manual power factor correction mode) for all the steps whose status has been set to "ON".

At the same time, the relay outputs set as "N.O. CONTACT ALARM" or "N.C. CONTACT ALARM" and associated to the "HIGH TEMPERATURE" or "GENERIC" alarm will be activated unless, through the **Alarm mask** (Chap.7.7.22) parameter, you decide to mask the alarms under certain operating conditions.

DISPLAYING

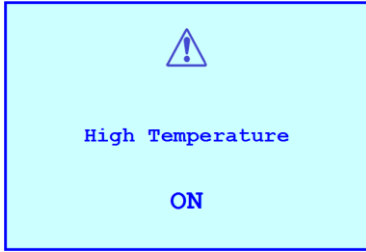

Regardless of the current displaying, the alarm will be indicated with a pop-up window lasting 3 seconds and containing the alarm symbol, the name of the alarm that will be activated and its "ON" status. Following:

- the controller will go back to the page displayed before the alarm activation;
- the alarm icon will be displayed in the status bar at the top left side.

The alarm will be anyway active in the Alarms state Menu (Chap. 8.7.1).

If you decide to mask the alarms under certain operating conditions, through the **Alarm mask** (Chap.7.7.22) parameter, the previous pop-up window will be displayed but not the alarm icon. The alarm will be anyway active in the Alarms state Menu.

STATISTICS

The alarm counter will be increased in the Alarms state Menu (Chap. 8.7.1) at every occurrence.

DEACTIVATION

The alarm is automatically deactivated if the temperature value stays below the value defined by parameter **Temp. Alarm** (Chap. 7.5.15) for a time (in sec) equal to the value of parameter **Temp. Alarm Delay** (Chap. 7.5.16).

RESET

Alarm can be manually reset from the page inside the Alarms state Menu by pressing key  (function possible only if **Alarm reset** = "ENABLED", refer to Chap.7.7.13).

8.7.2.8 Fan Control

ACTIVATION

The **fan control** is activated if the temperature measurement stay above the parameter defined by **Fan A. Thres.** (Chap.7.5.17) for a time (in sec) equal to the value of parameter **Fan A. Delay** (Chap.7.5.18).

MANAGEMENT

The activation of the **fan control** does not trigger any action on the inserted steps.

The Relay outputs set as "FAN OUTPUT" will be activated only if at least one step is inserted

DISPLAYING



Regardless of the current display, the activation will be indicated with a popup window lasting 3 seconds containing the fan symbol and its status "ON". Following:

- the controller will return to the page displayed before the fan activation.

The ON state will still be active in the Alarms state Menu (Chap. 8.7.1).

The icons corresponding to the relay outputs set as "FAN CONTROL", once activated, will start to rotate.

STATISTICS

The fan activation counter will be incremented in the Alarms state Menu (Chap. 8.7.1)

DEACTIVATION

The fan control is automatically deactivated as soon as the temperature value read by Regulator R8 remains below the value defined by the parameter **Fan A. Thres.** (Chap.7.5.17) decremented by 10°C (18°F) for a time (in seconds) equal to the value of the **Fan A. Delay** parameter (Chap.7.5.18)

RESET

It is possible to manually deactivate the fan control from the details page in the Alarms state Menu by pressing the key  (this is possible only if the parameter **Alarm reset** = "ENABLED", see Chap.7.7.13)

8.7.2.9 Overcompensation alarm

ACTIVATION

The **overcompensation alarm** is activated if the cosfi value stays above the numerical value corresponding to the most capacitive extreme value of the target cosfi range (defined by parameters **Target cosfi** [Chap.7.2.1](#), or **Cosfi time band 2**, **Cosfi time band 3** or **Cosfi TB4/GEN** according to current time band and the operating mode set in case of system in generation, refer to [Chap.7.2](#) and [Chap.7.3](#) and **Cosfi tolerance** [Chap. 7.2.2](#)) for a time (in hours) equal to the value of parameter **Hcosfi Alarm Delay** ([Chap.7.5.13](#)).

NOTE: the power factor overcorrection may be caused by:

- setting **Step n function** ([Chap.7.3.6.1](#)) = "ALWAYS ON STEP" for an excessive number of batteries;
- incorrect setting of the target cosphi range with respect to the type of load on the system;
- incorrect setting of the parameters related to the connections and the equipment in the **Setup Menu**.

MANAGEMENT

The activation of the **overcompensation alarm** will not affect the status of the inserted banks.

The relay outputs set as "N.O. CONTACT ALARM" or "N.C. CONTACT ALARM" and associated to the "OVERCOMPENSATION" or "GENERIC" alarm will be activated unless, through the **Alarm mask** ([Chap.7.7.22](#)) parameter, you decide to mask the alarms under certain operating conditions.

DISPLAYING



Regardless of the current displaying, the alarm will be indicated with a pop-up window lasting 3 seconds and containing the alarm symbol, the name of the alarm that will be activated and its "ON" status. Following:

- the controller will go back to the page displayed before the alarm activation;
- the alarm icon will be displayed in the status bar at the top left side.

The alarm will be anyway active in the **Alarms state Menu** ([Chap. 8.7.1](#)).

If you decide to mask the alarms under certain operating conditions, through the **Alarm mask** ([Chap.7.7.22](#)) parameter, the previous pop-up window will be displayed but not the alarm icon. The alarm will be anyway active in the **Alarms state Menu**.

STATISTICS

The alarm counter will be increased in the **Alarms state Menu** ([Chap. 8.7.1](#)) at every occurrence.

DEACTIVATION

The alarm is automatically deactivated as soon as the cosfi value drops below the numerical value corresponding to the most capacitive extreme value of the target cosfi range (defined by parameters **Target cosfi** [Chap.7.2.1](#), or **Cosfi time band 2**, **Cosfi time band 3** or **Cosfi TB4/GEN** according to current time band and the operating mode set in case of system in generation, refer to [Chap.7.2](#) and [Chap.7.3](#) and **Cosfi tolerance** [Chap. 7.2.2](#)).

RESET

Alarm can be manually reset from the page inside the **Alarms state Menu** by pressing key  (function possible only if **Alarm reset** = "ENABLED", refer to [Chap.7.7.13](#)).

8.7.2.10 Undercompensation alarm

ACTIVATION

The **undercompensation alarm** is activated if the cosfi value stays below the numerical value corresponding to the most inductive extreme value of the target cosfi range (defined by parameters **Target cosfi** [Chap.7.2.1](#), or **Cosfi time band 2**, **Cosfi time band 3** or **Cosfi TB4/GEN** according to current time band and the operating mode set in case of system in generation, refer to [Chap.7.2](#) and [Chap.7.3](#) and **Cosfi tolerance** [Chap. 7.2.2](#)) for a time (in hours) equal to the value of parameter **Lcosfi Alarm Delay** ([Chap.7.5.14](#)).

NOTE: the alarm condition may be caused by:

- incorrect sizing of the power factor correction equipment with respect to the system load;



- presence of degraded or broken batteries;

- incorrect setting of the parameters related to the power factor correction, the connections and the equipment in the Setup Menu.

MANAGEMENT

The activation of the **undercompensation alarm** will not affect the status of the inserted banks.

The relay outputs set as “N.O. CONTACT ALARM” or “N.C. CONTACT ALARM” and associated to the “UNDERCOMPENSATION” or “GENERIC” alarm will be activated unless, through the **Alarm mask** (Chap.7.7.22) parameter, you decide to mask the alarms under certain operating conditions.

DISPLAYING



Regardless of the current displaying, the alarm will be indicated with a pop-up window lasting 3 seconds and containing the alarm symbol, the name of the alarm that will be activated and its "ON" status. Following:

- the controller will go back to the page displayed before the alarm activation;
- the alarm icon will be displayed in the status bar at the top left side.

The alarm will be anyway active in the Alarms state Menu (Chap. 8.7.1).

If you decide to mask the alarms under certain operating conditions, through the **Alarm mask** (Chap.7.7.22) parameter, the previous pop-up window will be displayed but not the alarm icon. The alarm will be anyway active in the Alarms state Menu.

STATISTICS

The alarm counter will be increased in the Alarms state Menu (Chap. 8.7.1) at every occurrence.

DEACTIVATION

The alarm is automatically deactivated as soon as the cosfi value goes above the numerical value corresponding to the most inductive extreme value of the target cosfi range (defined by parameters **Target cosfi** (Chap.7.2.1), or **Cosfi time band 2**, **Cosfi time band 3** or **Cosfi TB4/GEN** according to current time band and the operating mode set in case of system in generation, refer to (Chap.7.2 and Chap.7.3 and **Cosfi tolerance** (Chap. 7.2.2)).

RESET

Alarm can be manually reset from the page inside the Alarms state Menu by pressing key  (function possible only if **Alarm reset** = “ENABLED”, refer to (Chap.7.7.13)).

8.7.2.11 Micro-interruption alarm

ACTIVATION

The **voltage dip** alarm is activated if the voltmetric input of the R8 Controller stays below 10% of the nominal value defined by parameter **VT secondary** (Chap. 7.1.8) for a time (in msec) equal to the value of parameter **Voltage dip** (Chap.7.7.19).

MANAGEMENT

The activation of the **voltage dip alarm** triggers the immediate and simultaneous disconnection of all steps. This process takes place in automatic power factor correction mode for all the inserted banks whose **Step n function (n=1÷11)** (Chap. 7.3.6.1) has been set to “STEP” or “ALWAYS ON STEP” and in manual power factor correction mode (refer to (Chap. 8.10 - Manual power factor correction mode)) for all the steps whose status has been set to "ON".

DISPLAYING



Regardless of the current displaying, the alarm will be indicated with a pop-up window lasting 3 seconds and containing the alarm symbol, the name of the alarm that will be activated and its "ON" status. Following:

- the controller will go back to the page displayed before the alarm activation;
- the alarm icon will be displayed in the status bar at the top left side.

The alarm will be anyway active in the Alarms state Menu (Chap. 8.7.1).



If you decide to mask the alarms under certain operating conditions, through the **Alarm mask** (Chap.7.7.22) parameter, the previous pop-up window will be displayed but not the alarm icon. The alarm will be anyway active in the Alarms state Menu.

STATISTICS

The alarm counter will be increased in the Alarms state Menu (Chap. 8.7.1) at each occurrence not causing the complete powering-off of the R8 Controller.

DEACTIVATION

The alarm is automatically deactivated after a time equal to the **Discharge time** Chap.7.3.4.

RESET

This alarm cannot be manually reset from the Alarms state Menu.

8.7.2.12 Step n breakage alarm (n=1,2,3,4,5)

ACTIVATION

The alarm **step n breakage (n=1÷11)** is activated if step n estimated reactive power decreases by a percentage equal to or higher than **Breakage thr.1** (if **Inductors** = "DISABLED") or **Breakage thr. 2** (if **Inductors** = "ENABLED"). For further details, refer to (Chap.7.7).

MANAGEMENT

The activation of **step n breakage alarm (n=1,2,3,4,5)** triggers the immediate disconnection of step n. This process takes place in automatic power factor correction mode for all the activated banks whose **Step n function (n=1÷11)** (Chap. 7.3.6.1) has been set to "STEP" or "ALWAYS ON STEP" and in manual power factor correction mode (refer to Chap. 8.10 - **Manual power factor correction mode**) for all the steps whose status has been set to "ON".

DISPLAYING



Regardless of the current displaying, the alarm will be indicated with a pop-up window lasting 3 seconds and containing the alarm symbol, the name of the alarm that will be activated and its "ON" status. Following:

- the controller will go back to the page displayed before the alarm activation;
- the alarm icon will be displayed in the status bar at the top left side.

The alarm will be anyway active in the Alarms state Menu (Chap. 8.7.1).

If you decide to mask the alarms under certain operating conditions, through the **Alarm mask** (Chap.7.7.22) parameter, the previous pop-up window will be displayed but not the alarm icon. The alarm will be anyway active in the Alarms state Menu.

STATISTICS

There is not a specific statistics for this alarm, in the Statistics Menu (Chap. 8.6) it will nevertheless be possible to display the estimated reactive power value of step n.

DEACTIVATION

The alarm cannot be deactivated, once a step is declared as broken, it will not be possible to use it again on the R8 Controller.

RESET

This alarm cannot be manually reset from the Alarms state Menu. Step n parameters and, consequently, the relevant breakage alarm can be reset through the Reset Menu (Chap.8.8).

GO BACK TO [USING THE CONTROLLER](#)

GO BACK TO [CONTENTS](#)

8.8 Reset menu

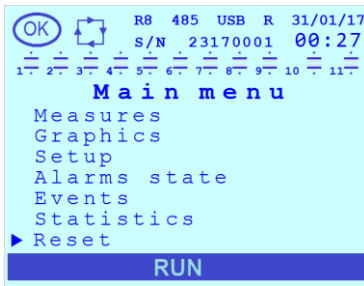

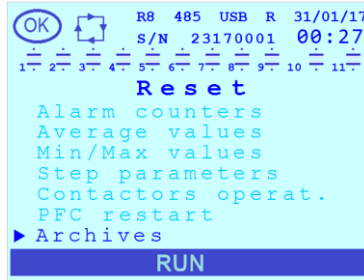
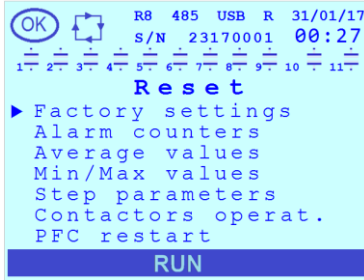

In the Main Menu page, through keys  or , move the cursor on “Reset” and

press key .





The Reset Menu contains the following items: **Factory settings**, **Alarm counters**, **Average values**, **Min / Max values**, **Step parameters**, **Contactors operat.**, **PFC restart** and **Archives**.

Some of the menu items contain other sub-menus. For further details, refer to the relevant chapters.

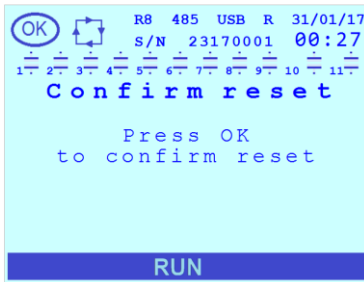
Through the keys  or , move the cursor on the relevant item and press key  to execute the reset command or access the associated sub-menu (where provided).



Confirmation will be requested upon pressing the key  before the reset. Press key  again to confirm.

8.8.1 Factory settings

Select this item to **Reset to factory settings** that will reset all parameters to the default values specified in **Chap. 7.8 - Parameter range and default values** and will force a restart of the R8 Controller followed by a **Complete auto-acquisition** procedure (for further details, refer to **Chap.6.2**).

ATTENTION: Choose this type of reset only if strictly necessary as all the values of the batteries, the nominal voltage of the capacitors, the discharge time and all the settings related to the alarms are reset to default.

8.8.2 Alarm counters

Select this item to **Reset the alarm counters** that will reset all alarm occurrences counters displayed in the Alarms state menu (**Chap.8.7.1**)

8.8.3 Average values

Select this item to **Reset the average values** that will reset the voltage, current, reactive power, active power, apparent power, cosfi, PF, and temperature measurements and the daily, weekly and monthly cosfi average value displayed in the Measurement Menu (**Chap. 8.3**) pages and available through the Communication Interfaces (**Chap.8.9**).



8.8.4 Min / Max values

Select this item to **Reset the minimum and maximum values** that will reset the voltage, current, reactive power, active power, apparent power, cosfi, PF, THDV%, THDI% and temperature minimum and maximum measurement values displayed in the Measurement Menu (**Chap. 8.3**) pages and available through the Communication Interfaces (**Chap.8.9**).

8.8.5 Step parameters

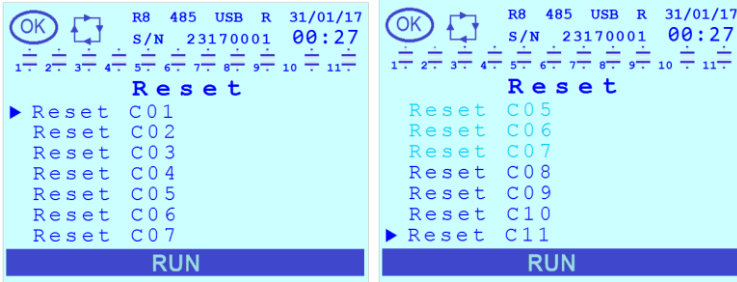
Select this item and press key  to view another list of parameters **Reset Cn (n=1÷11)**.



Through the keys  or , move the cursor on the relevant item and press key  to execute the command.

Generally speaking, at the moment of the execution, for each one of the previous commands relevant to the nth step, you will have:

- the reset to 0 of the step n **Insertions**;
- the reset to 0 of the step n **Working time**;
- the reset to 0 of **Contactor operations** associated with step n;
- the reset to the default “STEP” value for the parameter **Step n function (n=1÷11)** **Chap.7.3.6.1**;
- the reset of the estimated reactive power value **Real power** of step n to the nominal value defined by **Step n power (n=1÷11)** **Chap. 7.3.6.2** (as a consequence, any **Step n breakage alarm (n=1÷11)** will be reset as well, **Chap.8.7.2.12**).







The controller will automatically move to the **Setup Menu** page relating to parameter **Step Cn power** **Chap.7.3.6.2**:

Edit, if necessary, the suggested value. If the controller is installed on a Ducati Energia power factor correction equipment, the value to be entered is the one specified on equipment plate (for the entering mode of the numerical value, refer to **Chap. 7.9 - Entering modes for parameter values**).

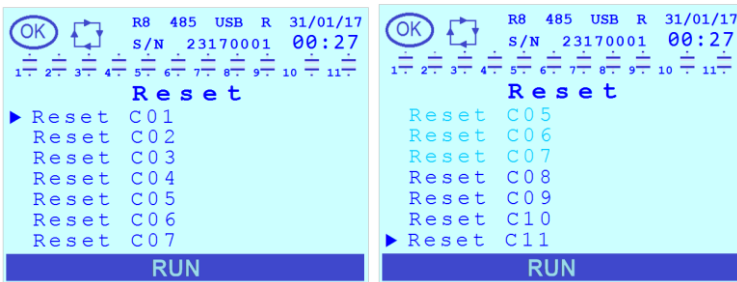
8.8.6 Contactors operations

Select this item and press key  to view another list of parameters **Reset Cn (n=1÷11)**.



Through the keys  or , move the cursor on the relevant item and press key  to execute the command.

The reset of the number of **step n contactor operations** will reset only the **Contact. operat.** parameter of the contactor associated to step n.

8.8.7 PFC restart

Select this item to **Reset the auto-acquisition**, the reset will force a R8 Controller restart, followed by an automatic check procedure of connections and bank reactive power, that will be:



- **complete** (for further details, refer to **Chap. 6.2 - Complete auto-acquisition**) if all the values of parameters **Step Cn power (n=1÷11)** (**Chap.7.3.6.2**) are equal to zero;
- **reduced** (for further details, refer to **Chap. 6.3 - Reduced auto-acquisition**) if at least one value of parameters **Step Cn power (n=1÷11)** (**Chap.7.3.6.2**) is not equal to zero.



8.8.8 Archives

Select this item and press key  to view another list of parameters: **Reset alarm archive**, **Reset event archive**, **Reset warning arch.**, **Reset log archive** and **Reset all archives**.



Through the keys  or , move the cursor on the relevant item and press key  to execute the command.

The selective deletion of the corresponding filing area will be carried out through the first 4 items. Use the **Reset all archives** item to delete the whole archive. For further details on the filing areas, refer to [Chap. 8.5 - Events menu.](#)



The deletion of archives may take a few minutes. During the operation, in the lower part there will be a progress bar.

GO BACK TO [USING THE CONTROLLER](#)

GO BACK TO [CONTENTS](#)



8.9 Communication interfaces

8.9.1 RS485 serial connection

NOTE: the RS485 serial connection is optional; refer to [Chap. 1 - R8 MODELS](#) for the list of models with this connection.

For further details on interface connection, refer to [Chap. 5.2 - RS485 serial connection](#).

For detailed information on configuration parameter settings, refer to [Chap. 7.4 - Communication interface settings](#).

For all the information on Modbus-RTU and ASCII Ducbus protocol specifications, refer to the documents available at the following link: ftp://ftp.ducatienergia.com/DucatiSistemi/Protocols_Analysers/.

8.9.2 868Mhz Radio

NOTE: the 868MHz Radio interface is optional; refer to [Chap. 1 - R8 MODELS](#) for the list of models with this connection.

To use the interface, a Energy Bridge device by Ducati Energia is required. The available documentation can be consulted at the website (following link): www.ducatienergia.com.

For detailed information on configuration parameter settings, refer to parameters **868MHz address** ([Chap. 7.7.16](#)) and **868MHz channel** ([Chap. 7.7.17](#)) present in the Setup Menu|Advanced Setup.

8.9.3 NFC

The NFC interface is present on all R8 models and its antenna is positioned in the bottom right area of the display of R8 Controller.

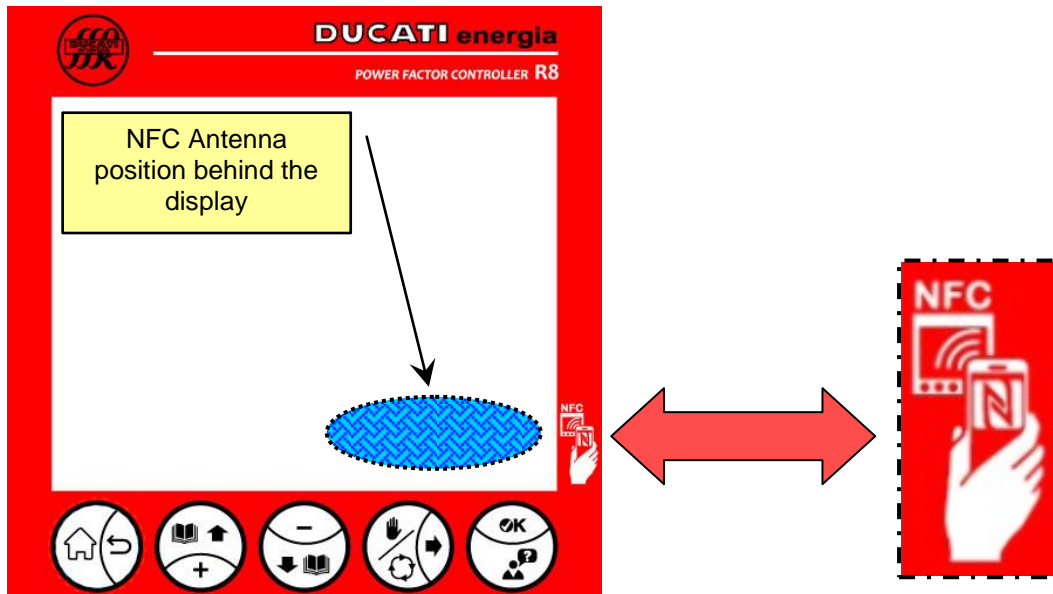

It is possible to interact with the R8 Controller through Android 5.0 (or next) devices with installed Ducati Smart Energy App, which can be downloaded by framing the QR-code at the side.

For any use information, refer to the on-line guide of the App:
<https://play.google.com/store/apps/details?id=it.ducatienergia.smartenergy>.



8.9.4 Bluetooth

NOTE: the Bluetooth interface is optional; refer to [Chap. 1 - R8 MODELS](#) for the list of models with this connection.



It is possible to interact with the R8 Controller through Android 5.0 (or next) devices and BT LE interface with installed Ducati Smart Energy App, which can be downloaded by framing the QR-code at the side.

For any use information, refer to the on-line guide of the App:
<https://play.google.com/store/apps/details?id=it.ducatienergia.smartenergy>

Once the R8 Controller is paired to the Android device a BT connection icon will be displayed steady on in the status bar at the bottom of the display. During data exchange the same icon will be flashing. For further details, refer to [Chap. 8.2.1](#).

8.9.5 USB

NOTE: the USB interface is optional; refer to [Chap. 1 - R8 MODELS](#) for the list of models with this connection.

To use the interface, connect a USB 2.0 pendrive with type A connector and FAT32 file system. For further details on the operations that can be carried out, refer to [Chap. 7.4.5](#).

Once the pendrive is connected and acknowledged, the active USB connection icon will be displayed steady on in the status bar at the bottom of the display. During data exchange the same icon will be flashing. For further details, refer to [Chap. 8.2.1](#).

8.9.6 Ethernet

NOTE: the Ethernet interface is optional; refer to [Chap. 1 - R8 MODELS](#) for the list of models with this connection.

To use the interface connect the Controller to the local network through a male RJ45 connector.

The Controller features a 10/100Base-T network board with RJ45 galvanically isolated connector with MDI/MDX auto-crossover and insulation voltage: 600V~.

Once the Controller is connected to a network the ETH connection icon will be displayed steady on in the status bar at the bottom of the display. For further details, refer to [Chap. 8.2.1](#) and [Chap. 7.4.6](#).

Information exchange is possible through the integrated web server and/or Modbus-TCP protocol. For further information consult the document "Webserver and Modbus-TCP R8 ETH manual" available at the following link: <https://www.ducatienergia.com/product.php?lang=en&id=8&cat=13&product=91>.



GO BACK TO [USING THE CONTROLLER](#)

GO BACK TO [CONTENTS](#)

8.10 Manual power factor correction mode

The manual operating mode allows to manually arm and disarm capacitor banks in case some checks have to be made on the equipment.

The manual power factor correction mode can be activated:

- by setting the parameter **Manual mode** = "ENABLED" from the Setup Menu ([Chap.7.3.2](#));
- from any page of the Measurement Menu, by pressing key  for at least 2sec;
- if the controller is waiting to perform the auto-acquisition procedure with no current or, in case of current, before setting the parameter **CT primary** (refer to **Complete auto-acquisition** [Chap. 6.2](#) and **Reduced auto-acquisition** [Chap. 6.3](#)), by pressing key  for at least 2sec.

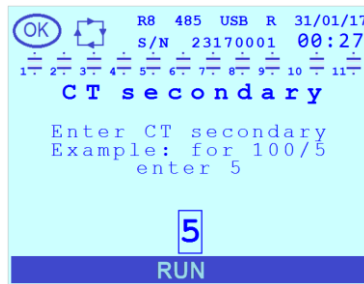
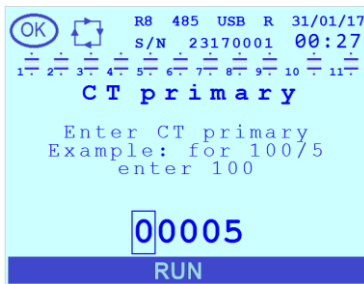

If the manual power factor correction mode is activated before the auto-acquisition procedure, the corresponding pages of the Setup Menu will prompt user to set the **CT primary** and the **CT secondary**



and, if necessary, the **Step voltage** (capacitor nominal voltage).





For further information on the entering procedure of the previous parameters, refer to [Chap. 7 - SETTINGS](#). The user will have then to set the output status by confirming or editing it in the pages displayed after.

Bank status setting (Manual status Cn (n=1÷11))



Initially, the page relevant to step C1 will be displayed showing as current status the one inherited from the previous configuration in **automatic mode** ("OFF" or "ON")

NOTE: if **Step 1 function** = "MAN/AUT OUTPUT" the status will be set to "ON" and cannot be changed.

To confirm current status, press key . To change status, press keys  or  to scroll the possible values [ON; OFF]. The change in progress can be cancelled by pressing key .

WARNING: by confirming the value, the new setting will be immediately implemented and the previous will be overwritten. If a bank for which the discharge time has not been elapsed is set to "ON", the insertion will take place after time elapsing.

Then the pages relating to steps from 2 to 11 will be displayed.



At the end of the sequence the R8 Controller will display in the bar at the top the active **Manual mode** icon (hand)



and will go to:

- the Measurement Menu page from where key  had been pressed for at least 2 sec;

or

- the page relevant to the P.F. Correction parameters of the Setup Menu in correspondence of the **Manual mode** parameter if the enabling has been carried out through this parameter.

NOTE 1: by switching to **Manual mode**, also the outputs for which the parameter **Step n function (n=1÷11)** [Chap.7.3.6.1](#) had been defined as "N.O. CONTACT ALARM", "N.C. CONTACT ALARM", "FAN OUTPUT" or "R8 RUNNING (RUN)" will be treated as simple contacts in N.O. logic whose state will be defined only by the parameter **Manual status Cn (n = 1 ÷ 11)** [Chap.7.3.6.4](#).

NOTE 2: by switching to **Manual mode**, the outputs for which the parameter **Step n function (n=1÷11)** had been defined as "MAN/AUT OUTPUT" will be closed and their status can not be changed by the user.

The manual power factor correction mode can be deactivated:

- from any page of the Measurement Menu, by pressing key  for at least 2sec;
- by accessing the Setup Menu and setting to "DISABLED" the **Manual mode** parameter ([Chap. 7.3.2](#)).

NOTE. if the **Manual mode** had been accessed before auto-acquisition, when quitting it the controller will perform the standard auto-acquisition procedure specified in **Complete auto-acquisition** [Chap. 6.2](#) and **Reduced auto-acquisition** [Chap. 6.3](#).

GO BACK TO [USING THE CONTROLLER](#)

GO BACK TO [CONTENTS](#)

8.11 Presence of blocking reactors

If controller is used on an equipment provided with capacitor banks with blocking reactors (or equivalent devices), make the following settings:

1.)

Enter, for the **Step voltage** parameter, [Chap. 7.3.1](#) a value equal to the network nominal voltage and not the capacitor nominal voltage.

For example, if network nominal voltage is 400V, enter "400".

2.)

Enter for parameters **Step Cn power (n=1÷11)** [Chap. 7.3.6.2](#) the values corresponding to capacitor equivalent reactive power at network voltage and not the relevant nominal value.

For example, if the capacitor nominal voltage specified on the plate is 5kVAr at a nominal voltage of 500V and the network nominal voltage is instead 400V, set the parameter to "4kVAr".

3.)

In the Advanced Setup Menu set the parameter **Inductors** = "ENABLED" [Chap. 7.7.8](#) and, if necessary, change the parameters **Degr. thres. 2** and **Breakage thr.2** ([Chap. 7.7.11](#) and [Chap. 7.7.12](#))



GO BACK TO [USING THE CONTROLLER](#)

GO BACK TO [CONTENTS](#)



8.12 Firmware, Bootloader and Language update

R8 Controller firmware, bootloader and languages can be updated by using one of the communication interfaces described in [Chap. 8.9 - Communication interfaces](#).

In particular:

- for RS485 serial connection (in the models where available), refer to the protocol document available at the following link: <https://www.ducatienergia.com/product.php?lang=en&id=8&cat=13&product=91>
- for 868Mhz Radio interface (in the models where available), refer to the documents of Ducati Energia Energy Bridge device, available at the website (following link): www.ducatienergia.com
- for NFC and Bluetooth interface (in the models where available), use an Android-compatible device and download the Ducati Smart Energy App by framing the QR-code:



- for the USB interface (in the models where available), save on a pendrive the update binary files available at the following link: https://ducnet.ducatienergia.com/firm_rego/R8/. For further details, refer to [Chap.7.4.5](#).

GO BACK TO [USING THE CONTROLLER](#)

GO BACK TO [CONTENTS](#)