

# TDS-06A

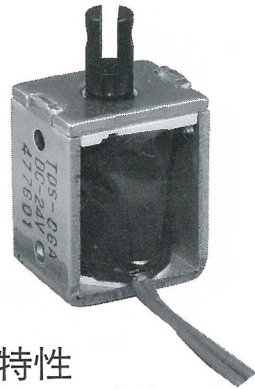

外形寸法  
Dimensions

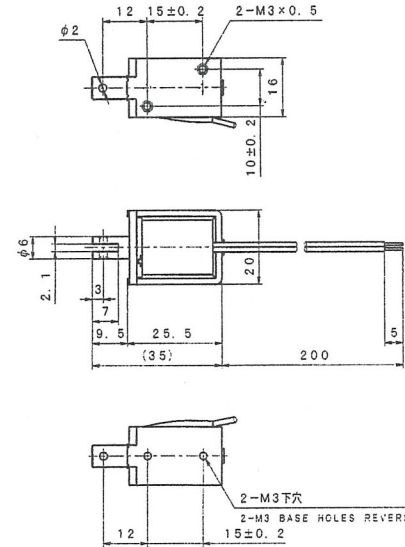

■ ストローク／吸引力特性  
Stroke and Pull Force Characteristics

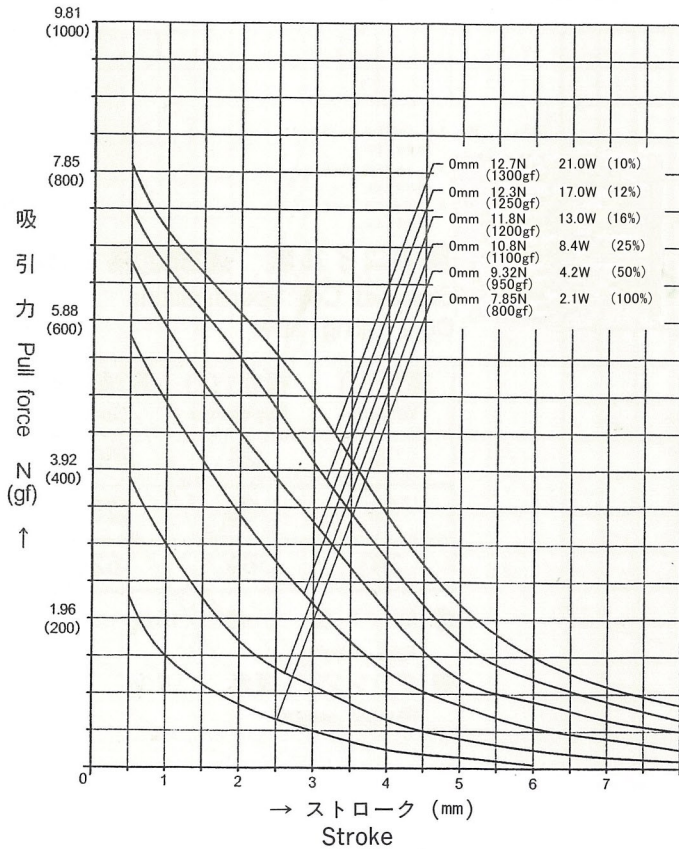

■ 容量／吸引力特性  
Power and Pull Force Characteristics

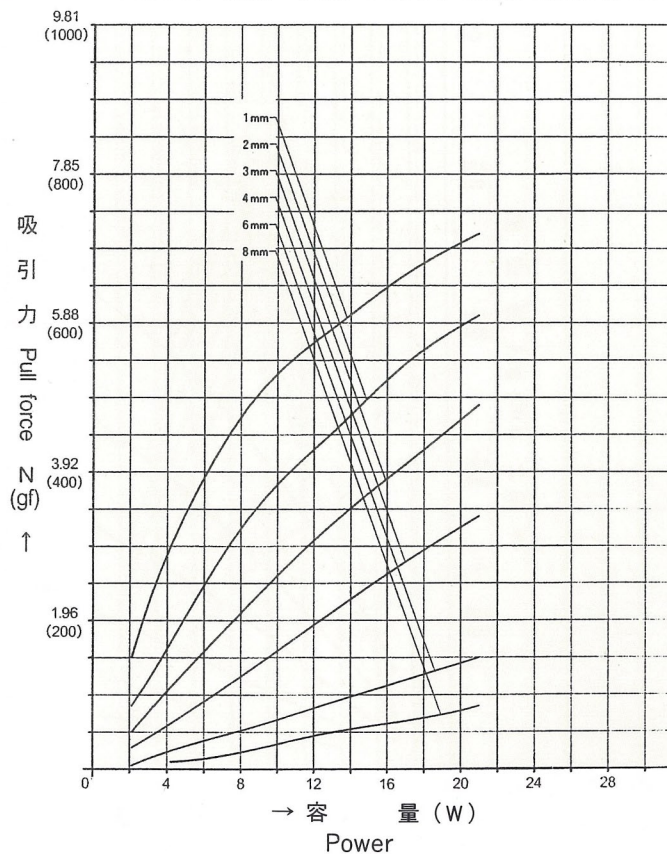

標準コイル表 連続定格2.1W  
Standard Coil Specifications  
Cont. rating 2.1W

電圧(V) Voltage	抵抗(Ω) Resistance	電流(mA) Current
6	17.1	351
12	69	174
24	274	87.6

- 総重量: 38.5g  
Total weight
- プランジャー重量: 5.1g  
Plunger weight