

Filter Code: **FPF20KR230BE-120**

Description: Fan Filter 230 Va.c.

MECHANICAL SPECIFICATIONS

Dimensions: **325x325x161 mm**
 Weight: **3,62 Kg**
 Type of material: **ABS/PC UL94V-0**
 Colour: **RAL 7032**
 Protection degree: **IP54 (EN60529)**
 Fastener: **by elastic hooks**
 Plate thickness: **from 1,5 to 2,2 mm**
 Storage temp.: **-30°C to +75°C**
 Electric connection: **by terminals block 2,5mm²**
 Earth connection: **by terminal block 2,5mm²**

OPERATING FEATURES

Rated voltage: **230 [V]**
 Rated frequency: **50/60 [Hz]**
 Rated power: **67/90 [W]**
 Rated current: **300/360 [mA]**
 Fan speed: **2480/2650 [rpm]**
 Noise: **61.0/63.0 [dB(A)]**
 Operating temp.: **- 10°C to +50°C**
 Relative humidity: **90% max**
 Life (L10) at 40°C: **53.000 hours**

PERFORMANCES and APPROVALS

Max air flow: **520/580 [m³/h]**
 Max static pressure: **160/186 [Pa]**
 Type of media: **P15/350S**
 Flammability: **F1 (DIN 53438)**
 Filtering class: **EU3 (DIN 24185)**
 Degree of separation: **85% (DIN 24185)**
 Degree of efficacy: **< 20% (DIN 24185)**
 Dust storage capacity: **600 g/m²**
 Approvals: 

Note: the media is washable

FAN FILTER DIMENSIONS [mm]

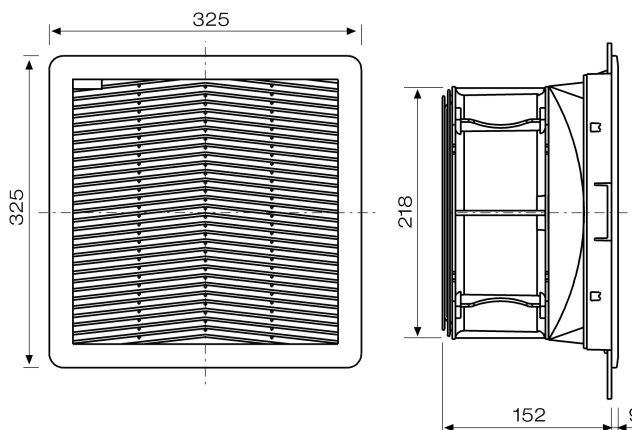

DIMENSIONS CUT-OUT [mm]

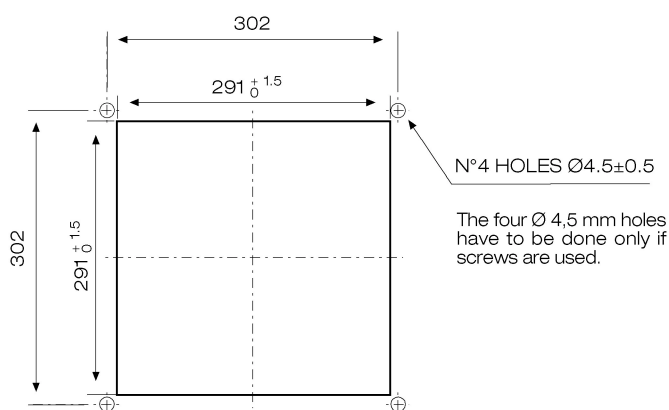

PERFORMANCE CURVES

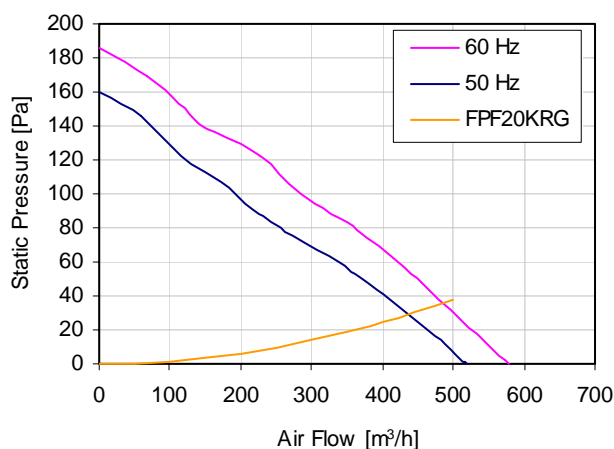

Please refer to our terms of sales including our warranty and limited liabilities clauses.