

## Control switch, Change over switch Flush mounting



Powering Business Worldwide™

**Part no.** T0-1-15431/E  
**Article no.** 019872

### Program

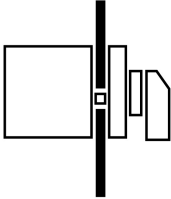
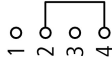
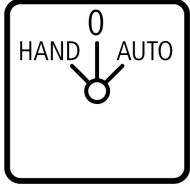
Range			Control switches									
Basic function			Hand/Auto switches									
Part group reference (e.g. DIL)			T0									
Design			Flush mounting									
												
Protection type			Front IP65									
Emergency stop			without emergency switching off/emergency stop function									
			With 0 (Off) position									
Spring-return			Without spring-return									
Contact sequence			<table border="1" data-bbox="914 786 1104 891"> <tr> <td>AUTO</td> <td>X</td> <td></td> </tr> <tr> <td>0</td> <td></td> <td></td> </tr> <tr> <td>HAND</td> <td></td> <td>X</td> </tr> </table> 	AUTO	X		0			HAND		X
AUTO	X											
0												
HAND		X										
Front plate no.			 <b>FS 1401</b>									
Main conducting paths												
No. of poles		M	1									
Max. motor rating												
AC-23A												
400/415 V 50-60 Hz	P	kW	6.5									
Rated uninterrupted current	I <sub>u</sub>	A	20									

### Approbationen

UL approval	Yes
CSA approval	Yes
Product Standards	UL 508; CSA-C22.2 No. 14-05; IEC/EN 60947-3; CE marking
UL File No.	E36332
UL CCN	NLRV
CSA File No.	12528
CSA Class No.	3211-05
NA Certification	UL listed, CSA certified
Suitable for	Branch circuits
Degree of Protection	IEC: IP65; UL/CSA Type 3R, 12

### General

Standards			IEC/EN 60947, VDE 0660, IEC/EN 60204, CSA, UL Switch-disconnectors to IEC/EN 60947-3 Load-break switches to IEC/EN 60947-3
Lifespan, mechanical	Operations	x 10 <sup>6</sup>	0.5
Maximum operating frequency		Operations	3000 h
Climatic proofing			Damp heat, constant, to IEC 60068-2-78; Damp heat, cyclical, to IEC 60068-2-30

Ambient temperature		°C	
Open		°C	- 25 - 50
Enclosed		°C	- 25 - 40
Mounting position			As required
Mechanical shock resistance to IEC 60068-2-27	Half-sinusoidal shock 20 ms	g	> 15

## Contacts

Rated operational voltage	$U_e$	V AC	690
Rated impulse withstand voltage	$U_{imp}$	V AC	6000
Overvoltage category/pollution degree			III/3
Rated uninterrupted current	$I_u$	A	
open	$I_u$	A	20
Enclosed	$I_u$	A	20
Load rating with intermittent operation, class 12			
AB 25 % DF		$\times I_e$	2
AB 40 % DF		$\times I_e$	1.6
AB 60 % DF		$\times I_e$	1.3
Short-circuit rating			
Fuse		A gG/gL	20
Rated short-time withstand current (1 s current)	$I_{cw}$	$A_{rms}$	320
Safe isolation to VDE 0106 Part 101 and Part 101/A1			
between the contacts		V AC	440
Switching angles		°	90 60 45 30
Contact units			11
Double-break contacts			max. 22
Current heat loss per contact at $I_e$		W	0.6

## Terminal capacities

Solid or stranded		mm <sup>2</sup>	1 x (1 - 2.5) 2 x (1 - 2.5)
Flexible with ferrule to DIN 46228		mm <sup>2</sup>	1 x (0.75 - 1.5) 2 x (0.75 - 1.5)
Terminal screw			M3.5
Tightening torque		Nm	1

## Switching capacity

AC		$\times U_s$	
Rated making capacity $\cos \varphi = 0.35$		A	130
Rated breaking capacity, motor load switch $\cos \varphi = 0.35$		A	
230 V		A	100
400 V		A	110
500 V		A	80
690 V		A	60
Rated operational current 440 V load-break switch AC-21A	$I_e$	A	20
Rating, AC-3 motor load switch	P	kW	
220/230 V	P	kW	3
230 V Star-delta	P	kW	4
400 V	P	kW	4
400 V Star-delta	P	kW	5.5
500 V	P	kW	5.5
500 V Star-delta	P	kW	7.5
690 V	P	kW	4

690 V Star-delta	P	kW	5.5
AC-23A Motor load switches (main switches maintenance switches)	P	kW	
230 V	P	kW	3.5
400 V	P	kW	6.5
500 V	P	kW	7.5
Rated operational current control switch AC-15			
230 V	I <sub>e</sub>	A	6
400 V	I <sub>e</sub>	A	4
500 V	I <sub>e</sub>	A	2
DC		x U <sub>s</sub>	
DC-1, Load-break switches L/R = 1 ms			
Rated operational current	I <sub>e</sub>	A	10
Voltage per contact pair in series		V	60
DC-21A	I <sub>e</sub>	A	
Rated operational current 240 V	I <sub>e</sub>	A	1
240 V Contacts		Quantity	1
DC-23A, motor load switch L/R = 15 ms			
24 V			
Rated operational current	I <sub>e</sub>	A	10
Contacts		Quantity	1
48 V			
Rated operational current	I <sub>e</sub>	A	10
Contacts		Quantity	2
60 V			
Rated operational current	I <sub>e</sub>	A	10
Contacts		Quantity	3
120 V			
Rated operational current	I <sub>e</sub>	A	5
Contacts		Quantity	3
240 V			
Rated operational current	I <sub>e</sub>	A	5
Contacts		Quantity	5
DC-13, Control switches L/R = 50 ms			
Rated operational current	I <sub>e</sub>	A	10
Voltage per contact pair in series		V	32
Control circuit reliability at 24 V DC, 10 mA	Fault probability	H <sub>F</sub>	< 10 <sup>-5</sup> , < 1 fault in 100000 operations

## Notes

**Notes** The following applies for solid, multiwire, and flexible terminal capacities:  
If 2 conductors are being used, a max. difference of 2 cross-section categories is permissible

## Technical data according to ETIM 4.0

Suitable for front mounting			YES
Complete device in housing			No
Suitable for rear mounting			No
Device construction			Flush-mounting device
Type of control element			Toggle
With 0 (off) position			YES
Max. rated operating voltage U <sub>e</sub> at AC		V	690
With retraction in 0-position			No
Rated uninterrupted current I <sub>u</sub>		A	20
Protection type (IP), at front			IP65
Front shield size			48x48 mm
Suitable for base fixing			No
Switch function			Changeover switch

Number of poles		1
Number of switch positions		2
Suitable for distribution board installation		No

## Characteristics

Form for ordering non-standard front plates

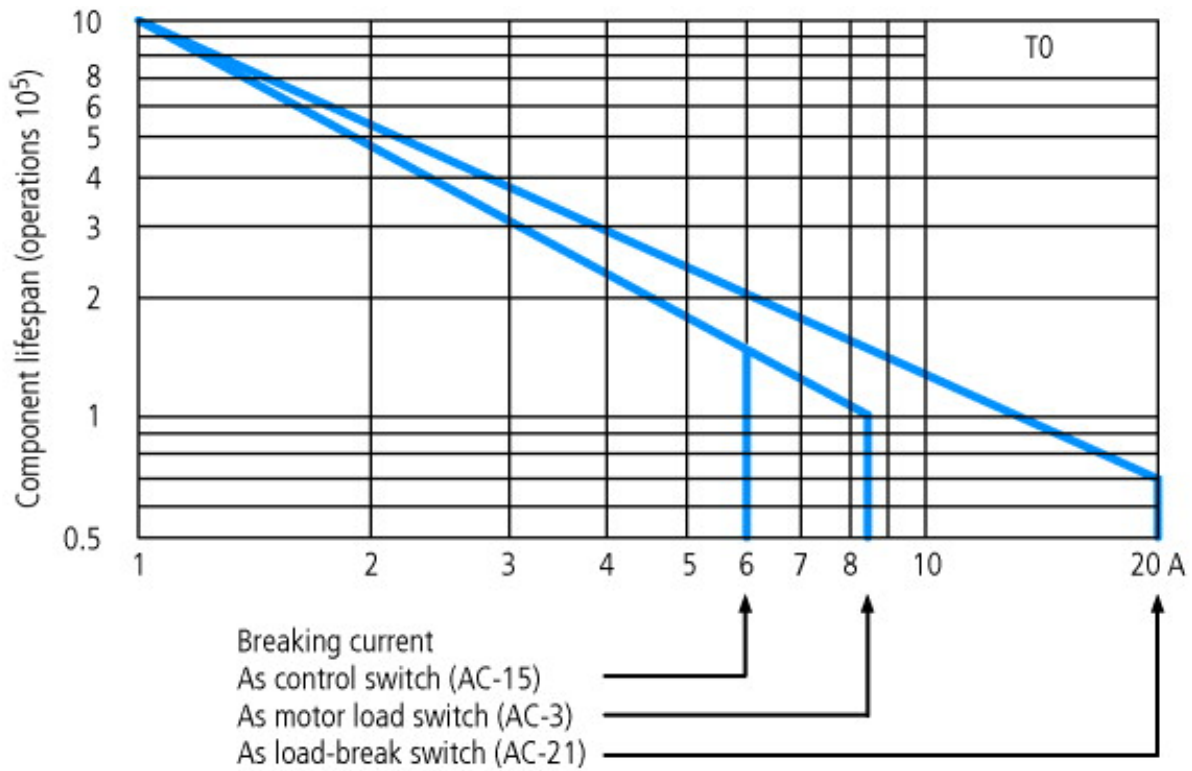

For utilisation category AC-4 (extreme load: 100 % inching, reversing or plugging)

The blocked rotor current of the motor should not exceed the rated current of the switch for AC-21A to ensure a reasonable device lifespan.

## Dimensions

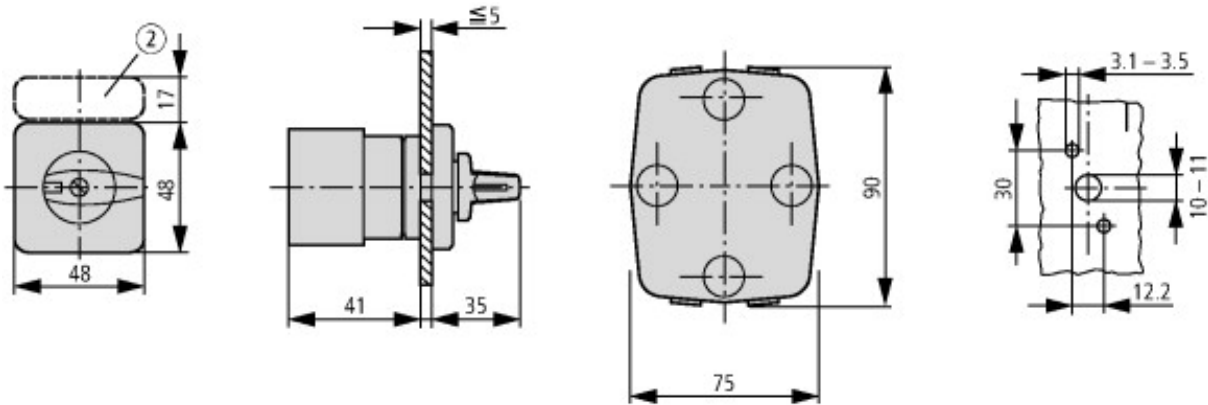

&#x2461; Label mount not included as standard  
 One contact unit depth: 9.5 mm

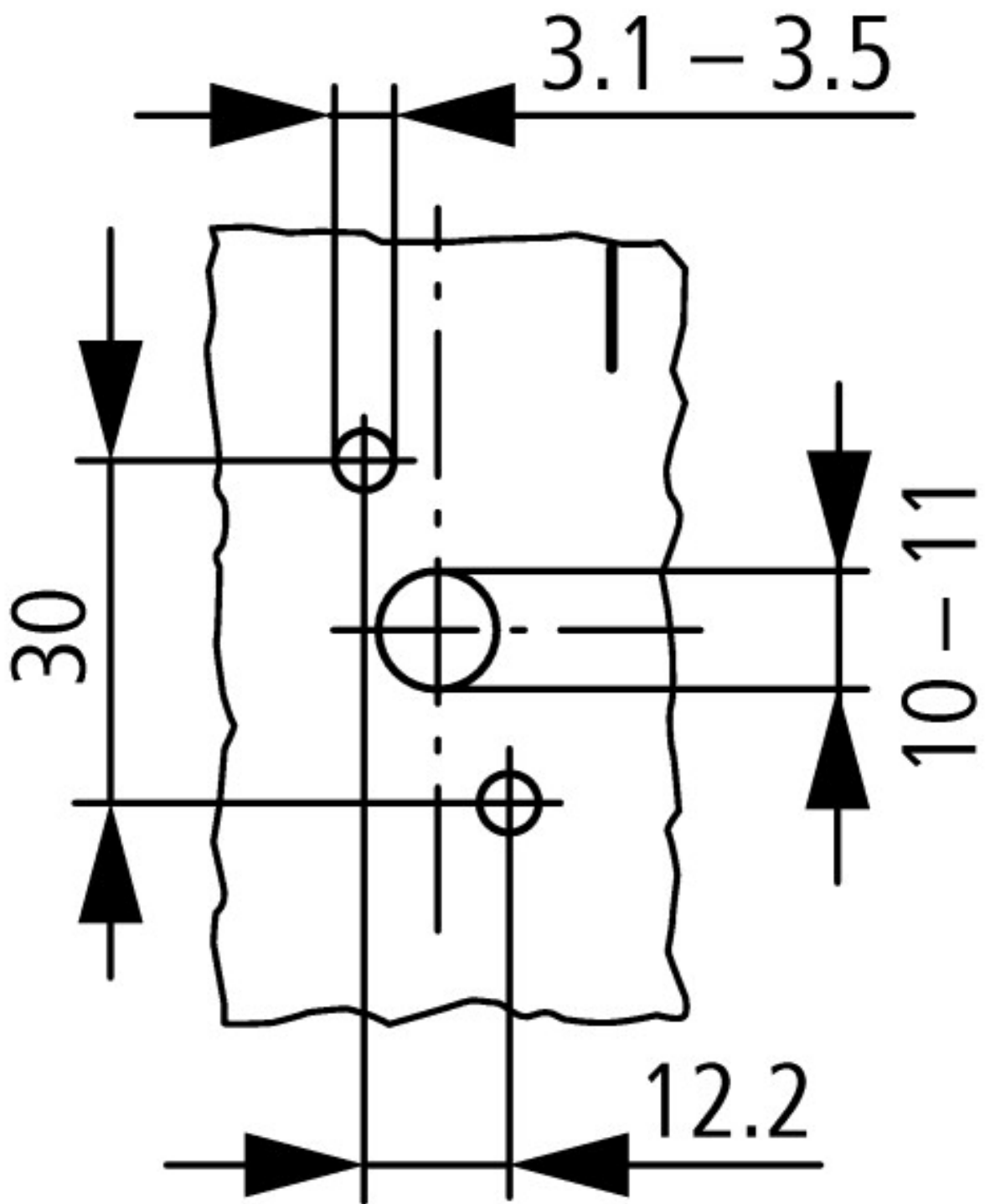

Diameter of drilled hole Door

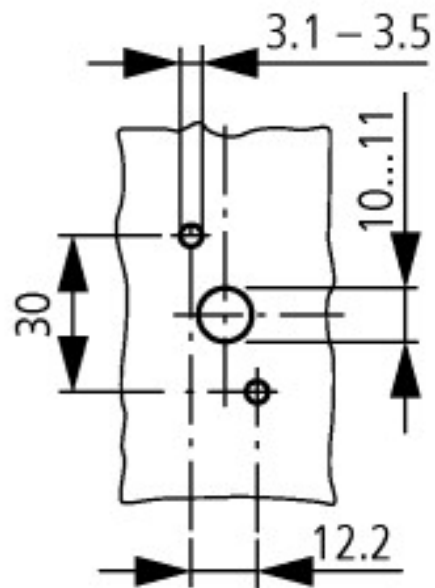
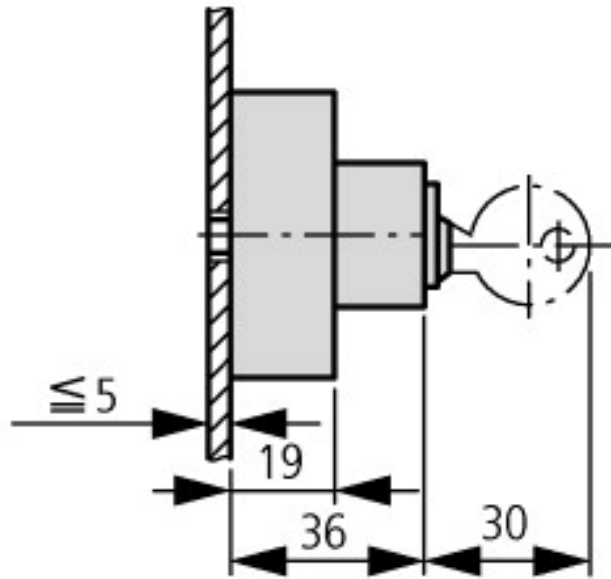
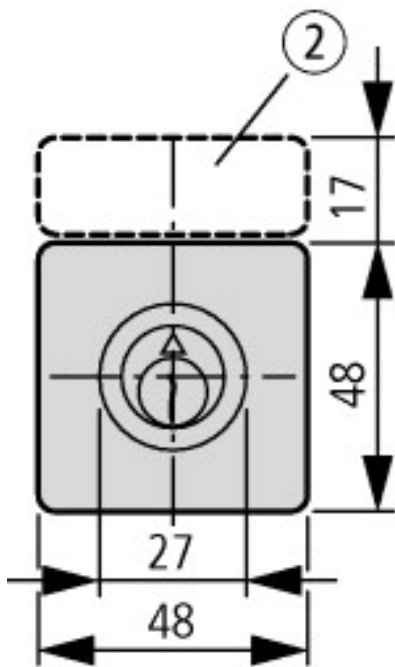

Key operation lock mechanism  
T0.../E + S-(SOND-)T0

### Additional product information (links)

AWA1150-0586 (IL03801020Z) Cam switch

[ftp://ftp.moeller.net/DOCUMENTATION/AWA\\_INSTRUCTIONS/05860709.pdf](ftp://ftp.moeller.net/DOCUMENTATION/AWA_INSTRUCTIONS/05860709.pdf)

#### Engineering

Technical overview

[ftp://ftp.moeller.net/DOCUMENTATION/PDF/GB/Ovt\\_t\\_p\\_Leistung\\_G.pdf](ftp://ftp.moeller.net/DOCUMENTATION/PDF/GB/Ovt_t_p_Leistung_G.pdf)

Key to part numbers, modular system

[ftp://ftp.moeller.net/DOCUMENTATION/PDF/GB/Ovt\\_t\\_p\\_Typenschlüssel\\_G.pdf](ftp://ftp.moeller.net/DOCUMENTATION/PDF/GB/Ovt_t_p_Typenschlüssel_G.pdf)

Ordering of non-standard switches

[ftp://ftp.moeller.net/DOCUMENTATION/PDF/GB/Bestellformulare\\_de.pdf](ftp://ftp.moeller.net/DOCUMENTATION/PDF/GB/Bestellformulare_de.pdf)