

L-7113VGC GREEN

### Features

- ULTRA BRIGHTNESS.
- BOTH DIFFUSED AND WATER CLEAR LENS ARE AVAILABLE.
- OUTSTANDING MATERIAL EFFICIENCY.
- RELIABLE AND RUGGED.
- IC COMPATIBLE/LOW CURRENT CAPABILITY.

### Description

The Green source color devices are made with InGaN on SiC Light Emitting Diode.

### Package Dimensions

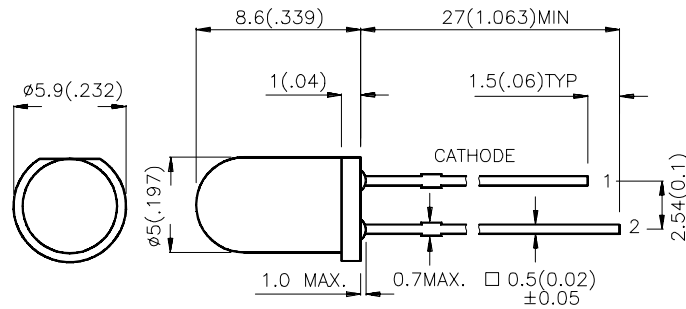

#### Notes:

1. All dimensions are in millimeters (inches).
2. Tolerance is  $\pm 0.25(0.01)$  unless otherwise noted.
3. Lead spacing is measured where the lead emerge package.
4. Specifications are subject to change without notice.

## Selection Guide

Part No.	Dice	Lens Type	Iv (mcd) @ 20 mA		Viewing Angle
			Min.	Typ.	θ1/2
L-7113VGC	GREEN (InGaN)	WATER CLEAR	1500	2300	20°

Note:

1. θ1/2 is the angle from optical centerline where the luminous intensity is 1/2 the optical centerline value.

## Electrical / Optical Characteristics at T<sub>A</sub>=25°C

Symbol	Parameter	Device	Typ.	Max.	Units	Test Conditions
λ <sub>peak</sub>	Peak Wavelength	Green	525		nm	IF=20mA
λ <sub>D</sub>	Dominate Wavelength	Green	520		nm	IF=20mA
Δλ 1/2	Spectral Line Halfwidth	Green	38		nm	IF=20mA
C	Capacitance	Green	53		pF	VF=0V;f=1MHz
V <sub>F</sub>	Forward Voltage	Green	4.0	4.5	V	IF=20mA
I <sub>R</sub>	Reverse Current	All		10	uA	VR = 5V

## Absolute Maximum Ratings at T<sub>A</sub>=25°C

Parameter	Green	Units
Power dissipation	110	mW
DC Forward Current	30	mA
Peak Forward Current [1]	150	mA
Reverse Voltage	5	V
Operating/Storage Temperature	-40°C To +85°C	
Lead Solder Temperature [2]	260°C For 5 Seconds	

Notes:

1. 1/10 Duty Cycle, 0.1ms Pulse Width.
2. 4mm below package base.

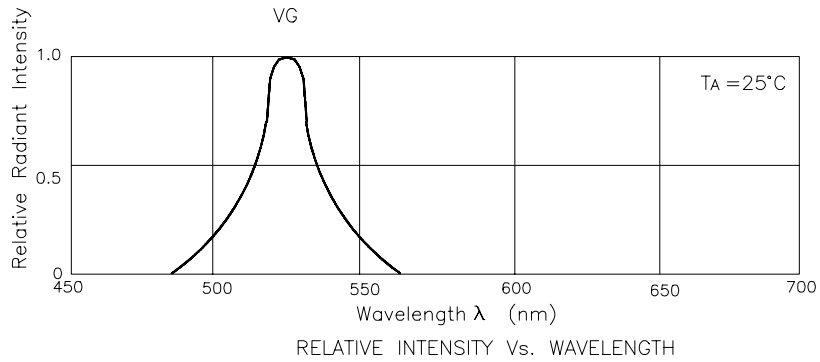

## Green L-7113 VGC

