

Carclo Optics

Guide to choosing secondary optics

Introduction

To quote from Pirelli's advertisement for tyre's, "Power is nothing without control" and equally the same analogy can be drawn with light. Seldom will the end user care about the total amount of light an LED radiates, rather what counts is where the light is going and how bright it is. Sending the light in the desired direction and obtaining the required brightness means controlling and directing the light output from the LED. (And it must not be forgotten that it is often just as important that light is kept away from other areas.) To do this usually requires more than just the pointing the LED's clear lens, (the primary optic), in the right direction. For the majority of applications producing the illumination in the required area and at the desired level requires additional or secondary optics. This guide aims to help in the selection of the best secondary optics and with the calculation of the illumination levels that will be achieved.



Information you need before you start

Although it sounds obvious, the first steps in selecting the best secondary optics for an application is to determine what illumination levels you want to achieve and over what area. Then from these two figures the total amount of light that will be needed can be calculated. Once you know how much light you need, it is then possible to decide what type of LED is required and how many. Only when the inputs to the optics, (the type and number of LED's), and the outputs, (the illumination level and beam shape), have been defined can the secondary optics be specified.



Carclo Technical Plastics

111 Buckingham Avenue, Slough, Berkshire SL1 4PF ENGLAND / 600 Depot Street Latrobe PA. 15650 USA

Web: www.carclo-optics.com e-mail: sales@carclo-optics.com

Tel UK: 0044 (0) 1753 575011 Tel USA 00 (1) 724 539 6982

Carclo Optics

Guide to choosing secondary optics

Quantifying light output

Often the first problem that someone new to lighting design has is defining the requirement in specific terms that can be used to calculate how much light is required. Carclo uses the metric system of light units for all our data sheets.

The metric unit of measurement for light seen by the human eye is called the lumen. The lumen is used to quantify the total amount of light radiated by a visible light source, in this case the LED. However what is important in most applications is how bright the light will be and this depends on what area the light is concentrated into.

To specify what illumination level is needed on a surface you need to calculate how much light is needed per square meter of surface. This unit of measurement is called Lux and is the amount of total light in lumens divided by the area being illuminated. Lux can be measured with a light meter.

If you need to specify the brightness of a light that is viewed at a significant distance, the unit of measurement to use is the candela. Candela is defined as the amount of light in lumens being radiated into each steradian of solid angle. (To calculate solid angle, imagine putting the light at the centre of a sphere with a radius of 1 meter. The amount of surface area in meters squared of the sphere that the light passes through is equivalent to the solid angle in steradians.)

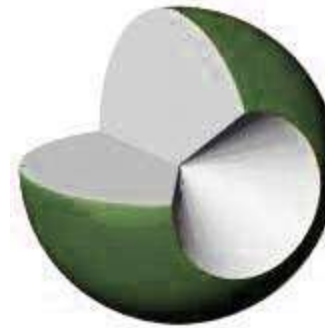

The removed cone has an apex solid angle of 1 Steradian

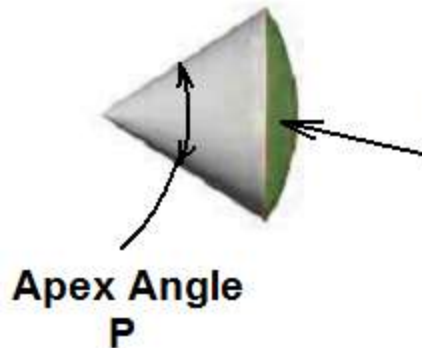

Solid Angle
 Ω

The solid angle of a cone with an apex angle of Ω is given by:

$$\Omega = 2\pi (1 - \cos(P))$$

Carclo Technical Plastics

111 Buckingham Avenue, Slough, Berkshire SL1 4PF ENGLAND / 600 Depot Street Latrobe PA. 15650 USA

Web: www.carclo-optics.com e-mail: sales@carclo-optics.com

Tel UK: 0044 (0) 1753 575011 Tel USA 00 (1) 724 539 6982

Carclo Optics

Converting from Candela to Lux

To convert from Candela values to Lux: Divide the Candela values by the square of the distance in meters from the light source to your illuminated surface.

Converting from Lux to Candela.

To convert from Lux to Candela: Multiply the Lux values by the square of the distance in meters from the light source to your illuminated surface.

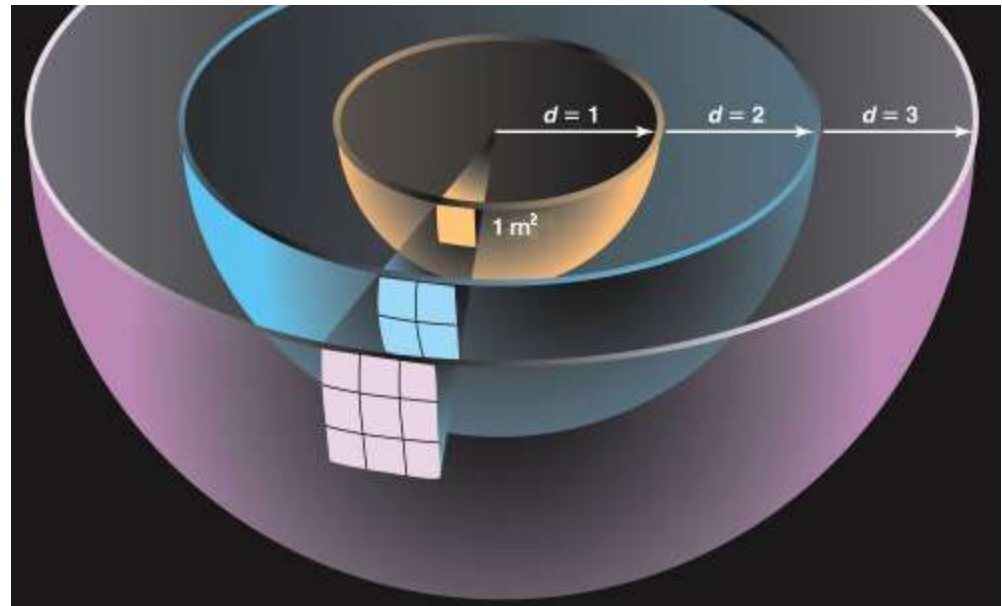
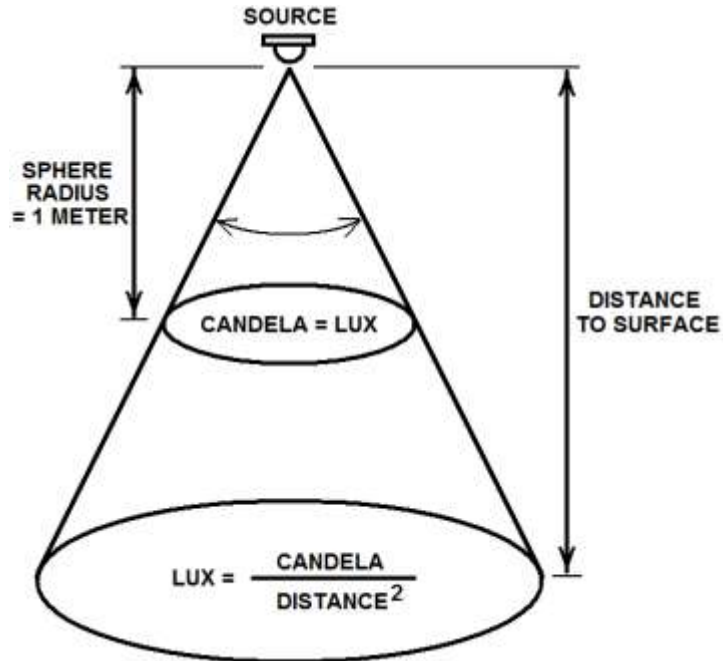

Carclo Technical Plastics

111 Buckingham Avenue, Slough, Berkshire SL1 4PF ENGLAND / 600 Depot Street Latrobe PA. 15650 USA

Web: www.carclo-optics.com e-mail: sales@carclo-optics.com

Tel UK: 0044 (0) 1753 575011 Tel USA 00 (1) 724 539 6982

Carclo Optics

Specifying the beam width

It is impossible to produce a perfect beam of light that does not spread out. The finite size of the emitting region of the LED source means that the light will diverge. How much the light spreads out depends on the emitting area of the LED chip and the type of secondary optics that are used. For this reason the beam widths that a secondary optic produces have been measured with each LED type that it can be used with

Secondary optics are characterised by how wide a beam they produce. The beam width is quoted as an angular width rather than a physical beam size at a given distance. The angular width the optics produce is usually specified by measuring the angular separation between the directions, (x_1 and x_2) at which the intensity has fallen to half its peak value, (f_{max}). This value is called the Full Width Half Maximum (FWHM) divergence.

It is important to note that it is **not** possible to calculate from the FWHM beam width how big the beam will look to the human eye. The visible size will depend on other factors such as the ambient lighting conditions and the colour LED that is being used. In very low ambient lighting conditions the beam will look far larger than the FWHM size because the observer looking at the spot of light can see clearly the very faint edges of the distribution. Against a bright background the beam size will look much more like the spot size that would be calculated from the FWHM angular width.

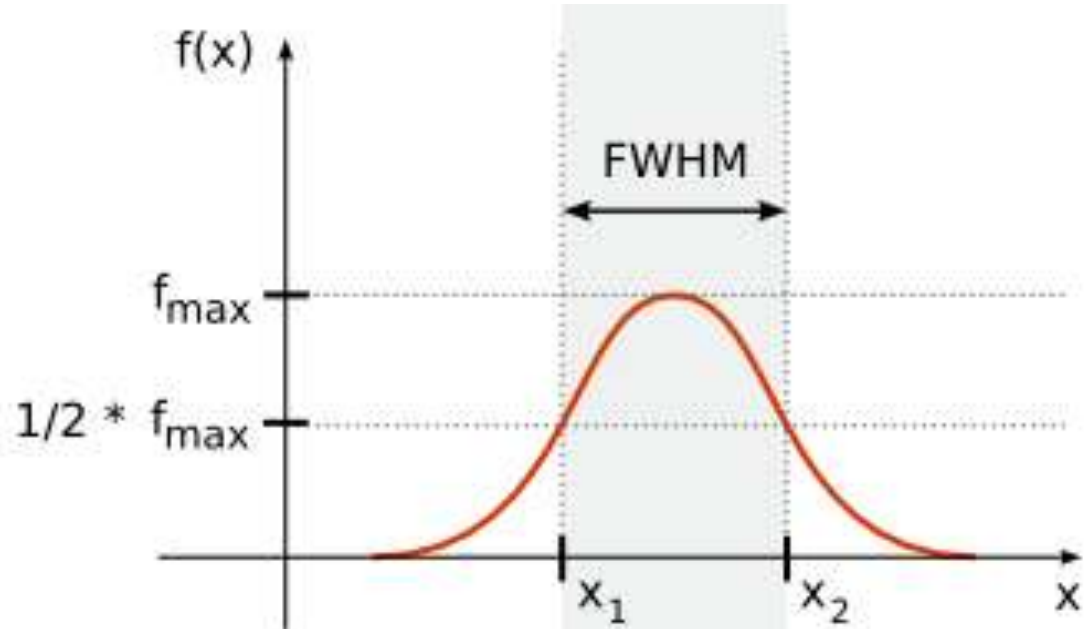

Carclo Technical Plastics

111 Buckingham Avenue, Slough, Berkshire SL1 4PF ENGLAND / 600 Depot Street Latrobe PA. 15650 USA

Web: www.carclo-optics.com e-mail: sales@carclo-optics.com

Tel UK: 0044 (0) 1753 575011 Tel USA 00 (1) 724 539 6982

Carclo Optics

Selecting Secondary Optics

The type of optics that will best suit an application are mainly determined by the beam width of the illumination that you want to produce. The type of LED selected as the light source will also effect the choice of optic. At the present time there is no industry standard package for high power LED's, different manufacturers have used different encapsulation techniques. Because of this some of Carclo's range of optics have variants particularly optimised for certain LED types.

Reflectors

To produce very wide beams, (up to 80 degrees FWHM) a reflector is the best choice. Reflectors have good efficiency and have a very sharp beam edge. The Carclo 80 degree reflector produces a very even circle of light and is ideally suited for applications such as the luminaries used on petrol station forecourts.

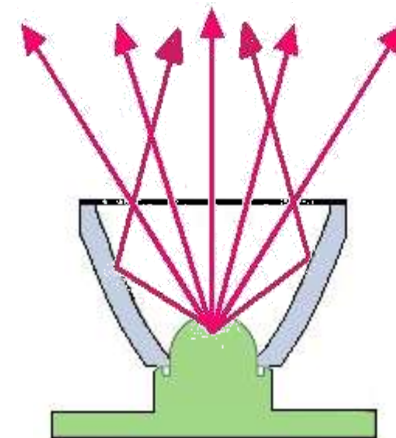

Carclo Technical Plastics

111 Buckingham Avenue, Slough, Berkshire SL1 4PF ENGLAND / 600 Depot Street Latrobe PA. 15650 USA

Web: www.carclo-optics.com e-mail: sales@carclo-optics.com

Tel UK: 0044 (0) 1753 575011 Tel USA 00 (1) 724 539 6982



Carclo Optics

TIR Optics

To produce smooth circular beams with FWHM angular widths between 12 and 35 degrees a Total Internal Reflecting (TIR) optic is the optimum solution. To produce elliptical beams the TIR optics are available with a linear ripple surface that generates an even intensity line. The classic 20mm diameter range of TIR optics are available for a wide range of LED types.

By using a proprietary frosted surface on the front of the optics Carclo are able to vary the angular beam width while maintaining a smooth profile without compromising the optical efficiency.

Elliptical beams are created through the use of linear ripple profiles moulded on the top surface of the TIR optics.

A range of larger 26.5mm diameter TIR optics is designed to produce narrow divergence output beams.

Manufactured in lens quality polycarbonate, Carclo's TIR optics have much higher temperature resistance than acrylic optics, (up to 125°C compared with 95°C) and carry a UL rating. These one piece optics are tough and impact resistant but precautions should be taken to prevent them from coming in to contact with organic solvents or vapour.

Diagram showing light ray paths through a TIR optic

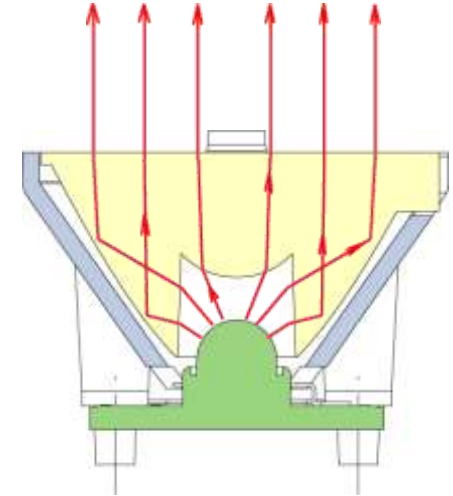

Picture showing Carclo 20mm diameter frosted optics



Carclo Technical Plastics

111 Buckingham Avenue, Slough, Berkshire SL1 4PF ENGLAND / 600 Depot Street Latrobe PA. 15650 USA

Web: www.carclo-optics.com e-mail: sales@carclo-optics.com

Tel UK: 0044 (0) 1753 575011 Tel USA 00 (1) 724 539 6982

Carclo Optics

Specialist Optics

To focus the light from an LED on to the end of a fibre bundle Carclo manufacture a standard 20mm diameter lens with an integrated focusing lens. Optimised for NA 0.5 fibre bundles with diameters of between 8 - 12mm this optic can be used to make compact microscope illumination systems.

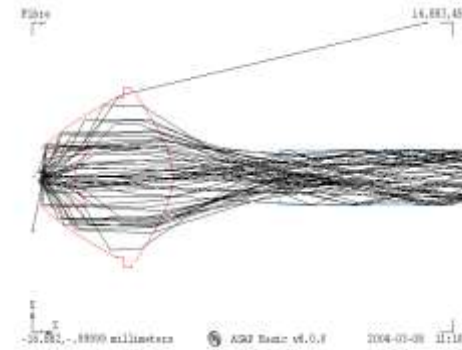

To produce the narrowest of beams Carclo manufacture catadioptric reflector optics. These are available in 50mm and 60mm diameters. The ability to create very tight beams with FWHM divergence as small as 3 degrees makes them ideally suited to applications such as beacons and spot lights.

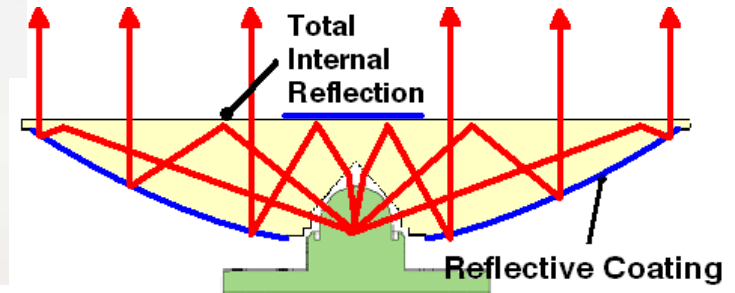

To create a narrow beam of light that covers 360 degrees around the LED Carclo manufacture side emitter optics for a number of LED's. These are ideally suited to a wide range of applications such as beacons and runway lighting. They also have applications in large area backlighting where they can be used to couple light in to standard 10mm thick PMMA or Polycarbonate sheets.

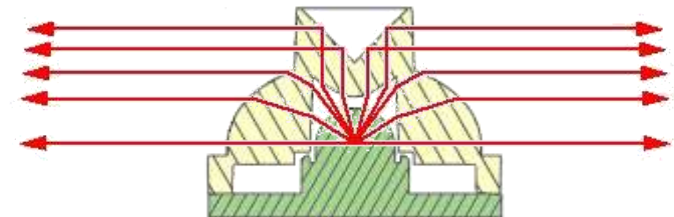

Carclo Technical Plastics

111 Buckingham Avenue, Slough, Berkshire SL1 4PF ENGLAND / 600 Depot Street Latrobe PA. 15650 USA

Web: www.carclo-optics.com e-mail: sales@carclo-optics.com

Tel UK: 0044 (0) 1753 575011 Tel USA 00 (1) 724 539 6982

Carclo Optics

HOLDERS for LED Optics

When mounting secondary optics it should be remembered that positioning the optics at the correct height relative to the LED is essential if you are to obtain the best efficiency and the correct beam width. Equally important is the alignment of the optic axis to the LED chip. If not correctly positioned the output beam will become uneven and offset. The axial placement accuracy required is dependent on the beam width of the optic. Generally the wider the beam divergence of the optic the more tolerant it will be of axial displacement. As a general guide, an accuracy of +/-0.2 mm is required for the optics that produce the narrowest beams, although for the widest beams this can be relaxed to +/-0.4mm.

To help users mount their optics at the correct focus height and to correctly align them to the LED chip Carclo supply a range of optic holders that mount on the PCB and locate the optics to the LED base.

All optical plastics can be damaged by organic solvents. In particular the optical surfaces can fog if exposed to organic solvent vapour. It is therefore very important that only low vapour adhesives are used for gluing holders to circuit boards.

Standard circular holders are for mounting both the 20mm and 26.5mm diameter to a wide range of LED types.

Many LED's are now available ready mounted on hexagonal 'starboard' style PCB's. Carclo has a range 'starboard' specific holders for many LED types.

Holders are available for mounting optics as triples in the standard 50mm diameter 'MR16' style fittings.

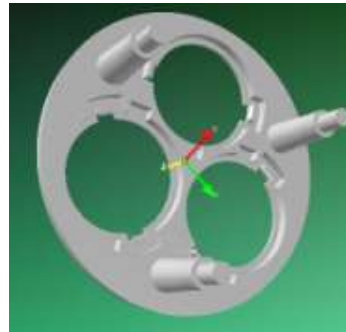

Carclo Technical Plastics

111 Buckingham Avenue, Slough, Berkshire SL1 4PF ENGLAND / 600 Depot Street Latrobe PA. 15650 USA

Web: www.carclo-optics.com e-mail: sales@carclo-optics.com

Tel UK: 0044 (0) 1753 575011 Tel USA 00 (1) 724 539 6982

LUXEON® I

20 & 26.5mm Range

“LUXEON® I, the original power LED, is the perfect solution for everyday purposes including automotive LED lighting, traffic signalling, signage, and a wide-range of general LED lighting applications. LUXEON® gives you total design freedom and unmatched brightness allowing you to create never before possible lighting solutions.” Reproduced from Future Lighting Solutions



Available from Future Lighting Solutions
www.futurelightingsolutions.com



Carclo Technical Plastics

111 Buckingham Avenue, Slough, Berkshire SL1 4PF ENGLAND / 600 Depot Street Latrobe PA. 15650 USA

Web: www.carclo-optics.com e-mail: sales@carclo-optics.com

Tel UK: 0044 (0) 1753 575011 Tel USA 00 (1) 724 539 6982



LUXEON® I 20mm range

Part No.	Description	White			Red/Amber			Cyan/Green			Warm White		
		FWHM#	EFF	Cd/lm	FWHM#	EFF	Cd/lm	FWHM#	EFF	Cd/lm	FWHM#	EFF	Cd/lm
10003	Plain Tight	8.0	84%	20	10.4	81%	16	9.6	82%	13	9.0	80%	10
10138	Frosted Narrow	12	87%	12	15	83%	11	15	87%	8.3	14	84%	7.0
10003/15	Ripple Medium	19	81%	5.2	13	81%	7.2	15	88%	7.3	17	81%	4.6
10139	Frosted Medium	22	83%	3.4	20	77%	4.8	20	80%	3.7	22	76%	3.0
10003/25	Ripple Wide	34	81%	2.3	16	80%	3.4	28	86%	2.7	18	80%	3.0
10140	Frosted Wide	35	81%	2.6	43	74%	1.6	34	78%	2.1	44	72%	1.3
10170	Wide angle reflector	79	91%	1.0	77	85%	1.3	78	92%	1.1	64	93%	1.4
10003/L25	Elliptical	40 X 11	78%	5.1	38 X 12	80%	4.4	40 X 14	85%	4.2	54 X 13	79%	3.0
10192	Elliptical Orthogonal*	10.6 X 40	78	5.1	1.9 X 38.2	80	4.4	13.7 X 39	85	4.2	12.8 X 35.5	79	3.0
10034	Fibre	Optimised for coupling into 0.5NA fibre bundles of 8 - 12mm diameter											

*Orthogonal is the elliptical beam turned through 90deg.
#Full Width Half Maximum i.e. total viewing angle



Part No.	Colour	Description	Part No.	Colour	Description
10012	Black	Circular custom boards	10109	Black	Triple holder 50 mm dia
10024	Clear	Circular custom boards	10110	White	Triple holder 50 mm dia
10035	White	Circular custom boards	10270	White	50mm Triple holder long leg
10026	Black	Star boards	10280	White	50 mm Triple holder short leg
10036	Clear	Star boards	10290	Black	50 mm Triple holder Long leg
10037	White	Star boards	10300	Black	50 mm Triple holder short leg
10041	Black	Triple holder 45 mm dia			
10042	White	Triple holder 45 mm dia			

LUXEON® I 20mm assembled in holder 10012

Part No.	Description	White			Red/Amber			Cyan/Green			Warm White		
		FWHM#	EFF	Cd/lm	FWHM#	EFF	Cd/lm	FWHM#	EFF	Cd/lm	FWHM#	EFF	Cd/lm
10800	Plain Tight	8.0	84%	20	10.4	81%	16	9.6	82%	13	9.0	80%	10
10801	Frosted Narrow	12	87%	12	15	83%	11	15	87%	8.3	14	84%	7.0
10802	Ripple Medium	19	81%	5.2	13	81%	7.2	15	88%	7.3	17	81%	4.6
10803	Frosted Medium	22	83%	3.4	20	77%	4.8	20	80%	3.7	22	76%	3.0
10804	Ripple Wide	34	81%	2.3	16	80%	3.4	28	86%	2.7	18	80%	3.0
10805	Frosted Wide	35	81%	2.6	43	74%	1.6	34	78%	2.1	44	72%	1.3
10806	Wide angle reflector	79	91%	1.0	77	85%	1.3	78	92%	1.1	64	93%	1.4
10807	Elliptical	40 X 11	78%	5.1	38 X 12	80%	4.4	40 X 14	85%	4.2	54 X 13	79%	3.0
10808	Elliptical Orthogonal*	10.6 X 40	78	5.1	1.9 X 38.2	80	4.4	13.7 X 39	85	4.2	12.8 X 35.5	79	3.0

*Orthogonal is the elliptical beam turned through 90deg.

#Full Width Half Maximum i.e. total viewing angle



LUXEON® I 20mm assembled in holder 10026

Part No.	Description	White			Red/Amber			Cyan/Green			Warm White		
		FWHM#	EFF	Cd/lm	FWHM#	EFF	Cd/lm	FWHM#	EFF	Cd/lm	FWHM#	EFF	Cd/lm
10809	Plain Tight	8.0	84%	20	10.4	81%	16	9.6	82%	13	9.0	80%	10
10810	Frosted Narrow	12	87%	12	15	83%	11	15	87%	8.3	14	84%	7.0
10811	Ripple Medium	19	81%	5.2	13	81%	7.2	15	88%	7.3	17	81%	4.6
10812	Frosted Medium	22	83%	3.4	20	77%	4.8	20	80%	3.7	22	76%	3.0
10813	Ripple Wide	34	81%	2.3	16	80%	3.4	28	86%	2.7	18	80%	3.0
10814	Frosted Wide	35	81%	2.6	43	74%	1.6	34	78%	2.1	44	72%	1.3
10815	Wide angle reflector	79	91%	1.0	77	85%	1.3	78	92%	1.1	64	93%	1.4
10816	Elliptical	40 X 11	78%	5.1	38 X 12	80%	4.4	40 X 14	85%	4.2	54 X 13	79%	3.0
10817	Elliptical Orthogonal*	10.6 X 40	78	5.1	1.9 X 38.2	80	4.4	13.7 X 39	85	4.2	12.8 X 35.5	79	3.0

*Orthogonal is the elliptical beam turned through 90deg.

#Full Width Half Maximum i.e. total viewing angle



LUXEON® I 26.5mm range

Part No.	Description	White			Red/Amber			Cyan/Green			Warm White		
		FWHM#	EFF	Cd/lm	FWHM#	EFF	Cd/lm	FWHM#	EFF	Cd/lm	FWHM#	EFF	Cd/lm
10048	Plain Tight	5.4	89%	50	6.8	85%	30	6.5	87%	35	11	79%	9.4
10124	Frosted Narrow	7.1	87%	29	9.8	84%	22	9.8	87%	23	13	79%	7.2
10108	Frosted Medium	18	87%	5.0	20	84%	5.2	20	85%	5.2	25	77%	2.7
10260	Frosted Wide	36.1	82%	2.3	36	84%	2.2	37	81%	2.1	49	71%	1.0
10049	Elliptical	47 X 6.8	83%	6.4	42 X 12	81%	4.5	45 X 11	82%	5.5	41 X 17	75%	2.5
10224	Elliptical Orthogonal*	6.8 X 47	83%	6.4	12 X 42	81%	4.5	11 X 45	82%	5.5	17 X 41	75%	2.5
10234	Elliptical Ramp optic	45 x 9	86%	14.8	44 x 11.8	87%	5.2	45 x 13	88%	4.9	45 x 20	80%	2.2

*Orthogonal is the elliptical beam turned through 90deg.

#Full Width Half Maximum i.e. total viewing angle

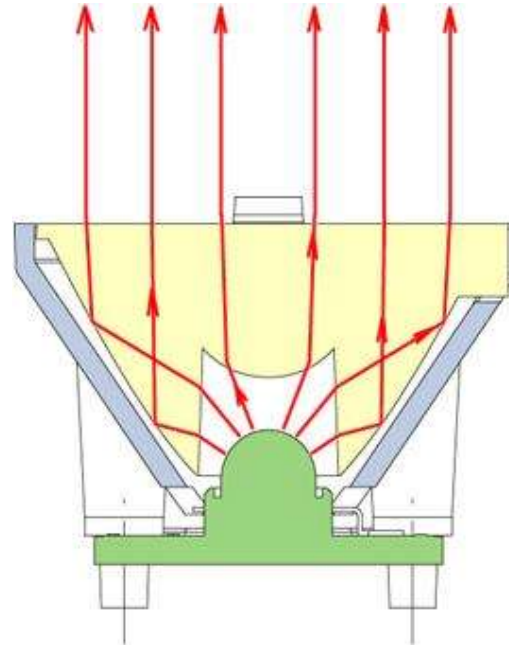

Part No.	Colour	Description
10064	Black	Holder long legs
10065	White	Holder long legs
10172	Black	Holder 0.8mm legs
10173	White	Holder 0.8mm legs
10174	Black	Holder no legs
10175	White	Holder no legs

LUXEON® I 26.5mm assembled in holder 10064

Part No.	Description	White			Red/Amber			Cyan/Green			Warm White		
		FWHM#	EFF	Cd/lm	FWHM#	EFF	Cd/lm	FWHM#	EFF	Cd/lm	FWHM#	EFF	Cd/lm
10900	Plain Tight	5.4	89%	50	6.8	85%	30	6.5	87%	35	11	79%	9.4
10901	Frosted Narrow	7.1	87%	29	9.8	84%	22	9.8	87%	23	13	79%	7.2
10902	Frosted Medium	18	87%	5.0	20	84%	5.2	20	85%	5.2	25	77%	2.7
10903	Frosted Wide	36.1	82%	2.3	36	84%	2.2	37	81%	2.1	49	71%	1.0
10904	Elliptical	47 X 6.8	83%	6.4	42 X 12	81%	4.5	45 X 11	82%	5.5	41 X 17	75%	2.5
1090	Elliptical Orthogonal*	6.8 X 47	83%	6.4	12 X 42	81%	4.5	11 X 45	82%	5.5	17 X 41	75%	2.5
10906	Elliptical Ramp optic	45 x 9	86%	14.8	44 x 11.8	87%	5.2	45 x 13	88%	4.9	45 x 20	80%	2.2

*Orthogonal is the elliptical beam turned through 90deg.

#Full Width Half Maximum i.e. total viewing angle

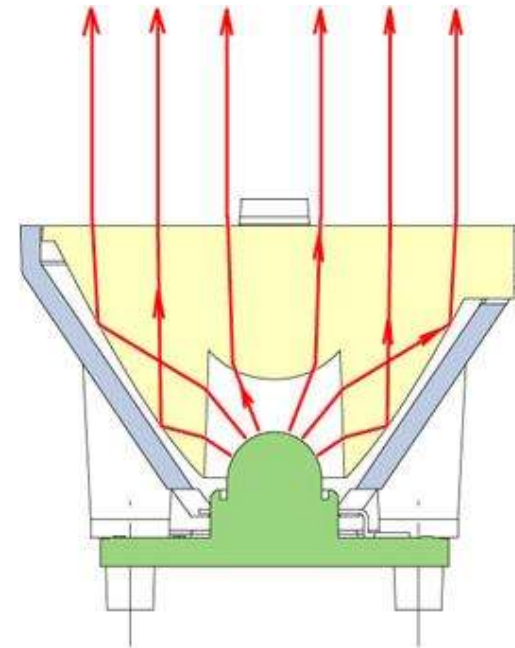

LUXEON® III

20 & 26.5mm Range

“LUXEON® III LEDs, the industry's most widely used high-power LEDs, deliver leading performance and value that enable lighting designers and engineers to develop applications at significantly lower costs, speeding the migration from conventional lamps to solid-state technology. With its rugged package design, superior thermal management and zero-stress encapsulation system, LUXEON® III is a clear technical and performance leader.” Reproduced from Future Lighting Solutions web site



Available from Future Lighting Solutions
www.futurelightingsolutions.com



Carclo Technical Plastics

111 Buckingham Avenue, Slough, Berkshire SL1 4PF ENGLAND / 600 Depot Street Latrobe PA. 15650 USA

Web: www.carclo-optics.com e-mail: sales@carclo-optics.com

Tel UK: 0044 (0) 1753 575011 Tel USA 00 (1) 724 539 6982



LUXEON® III 20mm range

Part No.	Description	White			Red			Blue			Green		
		FWHM	EFF	Cd/lm	FWHM	EFF	Cd/lm	FWHM	EFF	Cd/lm	FWHM	EFF	Cd/lm
10003	Plain Tight	6.9	82%	17	14	82%	8.1	9.0	87%	16	10	87%	19
10138	Frosted Narrow	14	88%	6.2	18	88%	6.5	14	87%	10	14	87%	10
10003/15	Ripple Medium	20	86%	4.7	22	88%	4.5	16	87%	6.0	16	87%	6.0
10139	Frosted Medium	20	85%	2.9	25	86%	3.5	19	84%	4.2	20	84%	4.3
10003/25	Ripple Wide	32	84%	2.2	26	87%	2.8	31	86%	2.8	27	85%	2.7
10140	Frosted Wide	35	80%	1.6	43	81%	1.5	37	80%	1.5	37	80%	1.5
10170	Wide Angle Reflector	72	91%	0.9	68	90%	1.2	75	93%	1.6	75	93%	1.6
10003/L25	Elliptical	40 x 11	83%	4.2	42 x 18	84%	3.5	39 x 12	85%	3.7	38 x 13	84%	3.8
10192	Elliptical Orthogonal	11 x 40	83%	4.2	17 x 44	87%	3.3	12 x 39	85%	3.9	13 x 38	84%	3.8
10034	Fibre	Optimised for coupling into 0.5NA fibre bundles of 8 - 12mm diameter											

*Orthogonal is the elliptical beam turned through 90deg.
#Full Width Half Maximum i.e. total viewing angle



Part No.	Colour	Description	Part No.	Colour	Description
10012	Black	Circular custom boards	10109	Black	Triple holder 50 mm dia
10024	Clear	Circular custom boards	10110	White	Triple holder 50 mm dia
10035	White	Circular custom boards	10270	White	50mm Triple holder long leg
10043	Black	Star boards	10280	White	50 mm Triple holder short leg
10045	Clear	Star boards	10290	Black	50 mm Triple holder Long leg
10044	White	Star boards	10300	Black	50 mm Triple holder short leg
10041	Black	Triple holder 45 mm dia			
10042	White	Triple holder 45 mm dia			

LUXEON® III 20mm assembled in holder 10012

Part No.	Description	White			Red			Blue			Green		
		FWHM	EFF	Cd/lm	FWHM	EFF	Cd/lm	FWHM	EFF	Cd/lm	FWHM	EFF	Cd/lm
10800	Plain Tight	6.9	82%	17	14	82%	8.1	9.0	87%	16	10	87%	19
10801	Frosted Narrow	14	88%	6.2	18	88%	6.5	14	87%	10	14	87%	10
10802	Ripple Medium	20	86%	4.7	22	88%	4.5	16	87%	6.0	16	87%	6.0
10803	Frosted Medium	20	85%	2.9	25	86%	3.5	19	84%	4.2	20	84%	4.3
10804	Ripple Wide	32	84%	2.2	26	87%	2.8	31	86%	2.8	27	85%	2.7
10805	Frosted Wide	35	80%	1.6	43	81%	1.5	37	80%	1.5	37	80%	1.5
10806	Wide Angle Reflector	72	91%	0.9	68	90%	1.2	75	93%	1.6	75	93%	1.6
10807	Elliptical	40 x 11	83%	4.2	42 x 18	84%	3.5	39 x 12	85%	3.7	38 x 13	84%	3.8
10808	Elliptical Orthogonal	11 x 40	83%	4.2	17 x 44	87%	3.3	12 x 39	85%	3.9	13 x 38	84%	3.8

*Orthogonal is the elliptical beam turned through 90deg.

#Full Width Half Maximum i.e. total viewing angle



LUXEON® III 20mm assembled in holder 10043

Part No.	Description	White			Red			Blue			Green		
		FWHM	EFF	Cd/lm	FWHM	EFF	Cd/lm	FWHM	EFF	Cd/lm	FWHM	EFF	Cd/lm
10818	Plain Tight	6.2	89%	17	14	82%	8.1	9.0	87%	16	10	87%	19
10819	Frosted Narrow	14	88%	6.2	18	88%	6.5	14	87%	10	14	87%	10
10820	Ripple Medium	20	86%	4.7	22	88%	4.5	16	87%	6.0	16	87%	6.0
10821	Frosted Medium	20	85%	2.9	25	86%	3.5	19	84%	4.2	20	84%	4.3
10822	Ripple Wide	32	84%	2.2	26	87%	2.8	31	86%	2.8	27	85%	2.7
10823	Frosted Wide	35	80%	1.6	43	81%	1.5	37	80%	1.5	37	80%	1.5
10824	Wide Angle Reflector	72	91%	0.9	68	90%	1.2	75	93%	1.6	75	93%	1.6
10825	Elliptical	40 x 11	83%	4.2	42 x 18	84%	3.5	39 x 12	85%	3.7	38 x 13	84%	3.8
10826	Elliptical Orthogonal	11 x 40	83%	4.2	17 x 44	87%	3.3	12 x 39	85%	3.9	13 x 38	84%	3.8

*Orthogonal is the elliptical beam turned through 90deg.

#Full Width Half Maximum i.e. total viewing angle



LUXEON® III 26.5mm range

Part No.	Description	White			Red			Blue			Green	
		FWHM	EFF	Cd/lm	FWHM	EFF	Cd/lm	FWHM	EFF	Cd/lm	FWHM	EFF
10048	Plain Tight	5.7	89%	28	10.7	93%	16.5	5.6	91%	53	6.4	92%
10124	Frosted Narrow	9	89%	16	15	93%	9.2	8.3	90%	25	9.3	92%
10108	Frosted Medium	20	88%	3.7	24	89%	3.8	18	87%	5.4	18.2	87%
10260	Frosted Wide	35.7	81%	2	39.3	82%	1.8	37.2	81%	2.7	37.3	81%
10049	Elliptical	45 x 10	88%	3.7	41 x 14	88%	4	46 x 11	87%	4.3	44 x 13	85%
10224	Elliptical Orthogonal	10 x 45	88%	3.7	14 x 46	88%	3.75	11 x 46	87%	4.3	13 x 44	85%
10234	Elliptical Ramp optic	45 x 10	88%	5.9	44 x 14	91%	4.6	47 x 9	88%	8.2	45 x 12	88%

*Orthogonal is the elliptical beam turned through 90deg.
 #Full Width Half Maximum i.e. total viewing angle

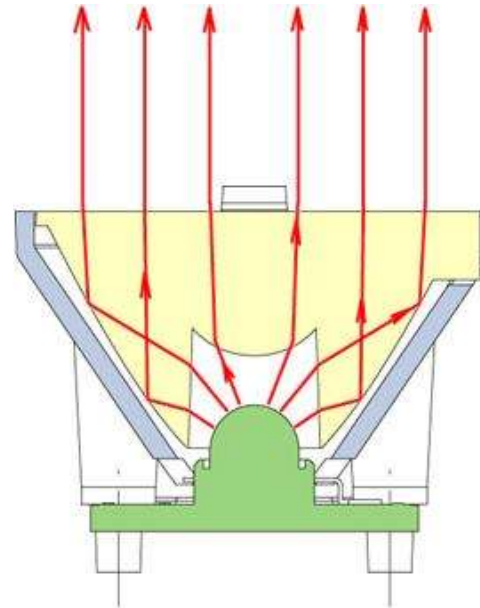

Part No.	Colour	Description
10076	Black	Holder long legs
10077	White	Holder long legs
10111	Black	Holder 0.8mm legs
10112	White	Holder 0.8mm legs
10174	Black	Holder no legs
10175	White	Holder no legs

LUXEON® III 26.5mm assembled in holder 10076

Part No.	Description	White			Red			Blue			Green		
		FWHM	EFF	Cd/lm	FWHM	EFF	Cd/lm	FWHM	EFF	Cd/lm	FWHM	EFF	Cd/lm
10048	Plain Tight	5.7	89%	28	10.7	99%	16.5	5.6	91%	53	6.4	92%	53
10124	Frosted Narrow	9	89%	16	15	93%	9.2	8.3	90%	25	9.3	92%	25
10108	Frosted Medium	20	88%	3.7	24	89%	3.8	18	87%	5.4	18.2	87%	5.4
10260	Frosted Wide	35.7	81%	2	39.3	82%	1.8	37.2	81%	2.7	37.3	81%	2.7
10049	Elliptical	45 x 10	88%	3.7	41 x 14	88%	4.7	46 x 11	87%	4.3	44 x 13	85%	4.3
10224	Elliptical Orthogonal	10 x 45	88%	3.7	14 x 46	88%	4.1	11 x 46	87%	4.3	13 x 44	85%	4.3
10234	Elliptical Ramp optic	45 x 10	88%	5.9	44 x 14	91%	4.6	47 x 9	88%	8.2	45 x 12	88%	5.0

*Orthogonal is the elliptical beam turned through 90deg.

#Full Width Half Maximum i.e. total viewing angle

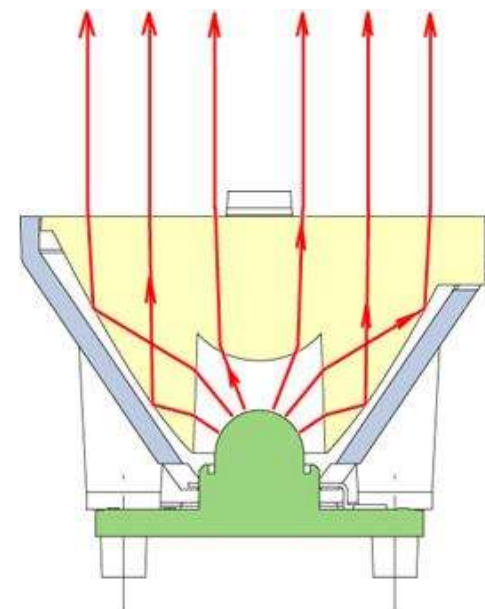

LUXEON® V

20 & 26.5mm Range

“LUXEON® V LEDs offer extreme luminous density, providing lumens per package 4X that of a LUXEON® I LED or up to 50X that of an alternative solid state light source. LUXEON® V creates new opportunities for solid state lighting to displace conventional lighting technologies. LUXEON® V LEDs serve a wide range of applications. For example, LUXEON® V white LEDs are ideally suited for portable lighting applications.” Reproduced from Future Lighting Solutions web site



Available from Future Lighting Solutions
www.futurelightingsolutions.com



Carclo Technical Plastics

111 Buckingham Avenue, Slough, Berkshire SL1 4PF ENGLAND / 600 Depot Street Latrobe PA. 15650 USA

Web: www.carclo-optics.com e-mail: sales@carclo-optics.com

Tel UK: 0044 (0) 1753 575011 Tel USA 00 (1) 724 539 6982



LUXEON® V 20mm range

Part No.	Description	White			Cyan/Green		
		FWHM#	EFF	Cd/lm	FWHM#	EFF	Cd/lm
10003	Plain Tight	17	83%	6.4	18	86%	10
10138	Frosted Narrow	19	88%	5.0	21	83%	8
10003/15	Ripple Medium	27	87%	3.3	27	87%	5.7
10139	Frosted Medium	25	85%	3.1	29	83%	4.6
10003/25	Ripple Wide	54	85%	1.8	34	84%	3.6
10140	Frosted Wide	42	80%	1.5	46	80%	2.5
10170	Wide angle reflector	77	92%	1.1	75	95%	2.9
10003/L25	Elliptical	39 X 19	84%	3.0	43 X 20	83%	4.6
10192	Elliptical Orthogonal*	19 X 39	84%	3.0	22 X 46	83%	4.4
10034	Fibre	Optimised for coupling into 0.5NA fibre bundles of 8 - 12mm diameter					

*Orthogonal is the elliptical beam turned through 90deg.
#Full Width Half Maximum i.e. total viewing angle



Part No.	Colour	Description	Part No.	Colour	Description
10012	Black	Circular custom boards	10109	Black	Triple holder 50 mm dia
10024	Clear	Circular custom boards	10110	White	Triple holder 50 mm dia
10035	White	Circular custom boards	10270	White	50mm Triple holder long leg
10043	Black	Star boards	10280	White	50 mm Triple holder short leg
10045	Clear	Star boards	10290	Black	50 mm Triple holder Long leg
10044	White	Star boards	10300	Black	50 mm Triple holder short leg
10041	Black	Triple holder 45 mm dia			
10042	White	Triple holder 45 mm dia			

LUXEON® V 20mm assembled in holder 10012

Part No.	Description	White			Cyan/Green		
		FWHM#	EFF	Cd/lm	FWHM#	EFF	Cd/lm
10800	Plain Tight	17	83%	6.4	18	86%	10
10801	Frosted Narrow	19	88%	5.0	21	83%	8
10802	Ripple Medium	27	87%	3.3	27	87%	5.7
10803	Frosted Medium	25	85%	3.1	29	83%	4.6
10804	Ripple Wide	54	85%	1.8	34	84%	3.6
10805	Frosted Wide	42	80%	1.5	46	80%	2.5
10806	Wide angle reflector	77	92%	1.1	75	95%	2.9
10807	Elliptical	39 X 19	84%	3.0	43 X 20	83%	4.6
10808	Elliptical Orthogonal*	19 X 39	84%	3.0	22 X 46	83%	4.4

*Orthogonal is the elliptical beam turned through 90deg.

#Full Width Half Maximum i.e. total viewing angle



LUXEON® V 20mm assembled in holder 10043

Part No.	Description	White			Cyan/Green		
		FWHM#	EFF	Cd/lm	FWHM#	EFF	Cd/lm
10818	Plain Tight	17	83%	6.4	18	86%	10
10819	Frosted Narrow	19	88%	5.0	21	83%	8
10820	Ripple Medium	27	87%	3.3	27	87%	5.7
10821	Frosted Medium	25	85%	3.1	29	83%	4.6
10822	Ripple Wide	54	85%	1.8	34	84%	3.6
10823	Frosted Wide	42	80%	1.5	46	80%	2.5
10824	Wide angle reflector	77	92%	1.1	75	95%	2.9
10825	Elliptical	39 X 19	84%	3.0	43 X 20	83%	4.6
10826	Elliptical Orthogonal*	19 X 39	84%	3.0	22 X 46	83%	4.4

*Orthogonal is the elliptical beam turned through 90deg.
 #Full Width Half Maximum i.e. total viewing angle



LUXEON® V 26.5mm range

Part No.	Description	White			Blue		
		FWHM	EFF	Cd/lm	FWHM	EFF	Cd/lm
10048	Plain Tight	12	88%	13	12	91%	18
10124	Frosted Narrow	13	87%	12	16	90%	13.3
10108	Frosted Medium	22	87%	4.4	26	90%	5.3
10260	Frosted Wide	36.4	81.4%	2	38.5	80.3%	1.8
10049	Elliptical	42 x 14	86%	3.9	45 x 15	87%	6.1
10224	Elliptical Orthogonal	14 x 42	86%	3.9	16 x 46	84%	3.1
10234	Elliptical Ramp optic	45 x 14	86%	4.1	45 x 14	87%	4.1

*Orthogonal is the elliptical beam turned through 90deg.
 #Full Width Half Maximum i.e. total viewing angle

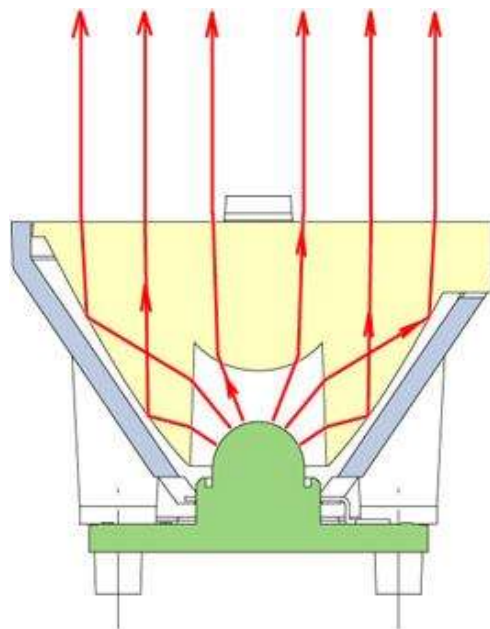

Part No.	Colour	Description
10076	Black	Holder long legs
10077	White	Holder long legs
10111	Black	Holder 0.8mm legs
10112	White	Holder 0.8mm legs
10174	Black	Holder no legs
10175	White	Holder no legs

LUXEON® V 26.5mm assembled in holder 10076

Part No.	Description	White			Blue		
		FWHM	EFF	Cd/lm	FWHM	EFF	Cd/lm
10907	Plain Tight	12	88%	13	12	91%	18
10908	Frosted Narrow	13	87%	12	16	90%	13.3
10909	Frosted Medium	22	87%	4.4	26	90%	5.3
10910	Frosted Wide	36.4	81.4%	2	38.5	80.3%	1.8
10911	Elliptical	42 x 14	86%	3.9	45 x 15	87%	6.1
10912	Elliptical Orthogonal	14 x 42	86%	3.9	16 x 46	84%	3.1
10913	Elliptical Ramp optic	45 x 14	86%	4.1	45 x 14	87%	4.1

*Orthogonal is the elliptical beam turned through 90deg.

#Full Width Half Maximum i.e. total viewing angle

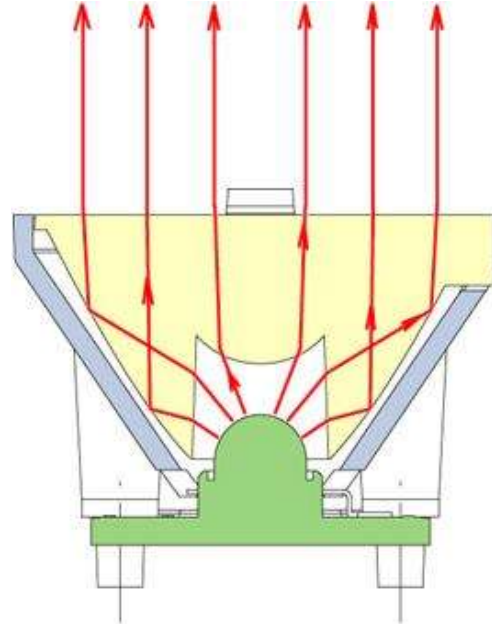

LUXEON® K2

20 & 26.5mm Range

“LUXEON® K2 Power LEDs establish elevated standards for light output, thermal management, cost and manufacturability. LUXEON® K2 gives you the world's best LED light output with 140 or more lumens in white, outstripping the performance of other power LEDs by 15 to 30% and significantly lowering the cost per lumen.”

“**LUXEON K2 with TFFC** is the first of a new class of products that will deliver more light and higher efficacy and lower the cost of light. Binned and tested at 1A, and with minimum flux bins of 160, 180 and 200 lumens, LUXEON K2 with TFFC LEDs are enabling never before possible lighting solutions.” Reproduced from Future Lighting Solutions web site



Available from Future Lighting Solutions
www.futurelightingsolutions.com



Carclo Technical Plastics

111 Buckingham Avenue, Slough, Berkshire SL1 4PF ENGLAND / 600 Depot Street Latrobe PA. 15650 USA

Web: www.carclo-optics.com e-mail: sales@carclo-optics.com

Tel UK: 0044 (0) 1753 575011 Tel USA 00 (1) 724 539 6982



LUXEON® K2 20mm range

Part No.	Description	White			TTFC White			Red/Amber			Cyan/Green		
		FWHM	EFF	Cd/lm	FWHM	EFF	Cd/lm	FWHM	EFF	Cd/lm	FWHM	EFF	Cd/lm
10003	Plain Tight	7.9	84%	28	7	85%	28.7	8.2	89%	28	8.6	91%	18
10138	Frosted Narrow	15	88%	9.2	10	88.3%	17.5	11	89%	18	14	89%	8.7
10003/15	Ripple Medium	19	82%	5.4	27	84%	4.4	13	90%	11	14	90%	7.3
10139	Frosted Medium	20	80%	4.1	18	87.4%	5.4	20	90%	6.1	20	88%	3.9
10003/25	Ripple Wide	32	81%	2.3	42	87.2%	2.1	15	90%	5.2	18	90%	3.3
10140	Frosted Wide												
10170	Wide angle reflector	70	92%	0.73	69	92.5%	0.87	72	91%	2.2	62	91.5%	0.7
10003/L25	Elliptical	45 X 10	87%	5.36	44 x 8	87.8%	6.62	43 x 10	93.3%	6.4	47.5 x 10	88%	4.9
10192	Elliptical Orthogonal*	10 X 47.5	87.6%	4.91	48 x 8	88.9%	5.8	9 x 45.5	93%	6.1	10 x 47.4	89%	4.8
10034	Fibre	Optimised for coupling into 0.5NA fibre bundles of 8 - 12mm diameter											

*Orthogonal is the elliptical beam turned through 90deg.

#Full Width Half Maximum i.e. total viewing angle

Please note the 10140 does not current fit on a K2



Part No.	Colour	Description	Part No.	Colour	Description
10119	Black	Holder Circular	10261	Black	Star board Feet
10120	Clear	Holder Circular	10262	White	Star board Feet
10121	White	Holder Circular	10263	Clear	Star board Feet
10272	White	50mm Triple holder long leg	10264	Black	Star board no Feet
10282	White	50 mm Triple holder short leg	10265	White	Star board no Feet
10292	Black	50 mm Triple holder Long leg	10266	Clear	Star board no Feet
10302	Black	50 mm Triple holder short leg			

LUXEON® K2 20mm assembled to holder 10119

Part No.	Description	White			TTFC White			Red/Amber			Cyan/Green		
		FWHM#	EFF	Cd/lm	FWHM#	EFF	Cd/lm	FWHM#	EFF	Cd/lm	FWHM#	EFF	Cd/lm
10827	Plain Tight	7.9	84%	28	7	855	28.7	8.2	89%	28	8.6	91%	18
10828	Frosted Narrow	15	88%	9.2	10	88%	17.5	11	89%	18	14	89%	8.7
10829	Ripple Medium	19	82%	5.4	27	84%	4.4	13	90%	11	14	90%	7.3
10830	Frosted Medium	20	80%	4.1	18	87%	5.4	20	90%	6.1	20	88%	3.9
10831	Ripple Wide	32	81%	2.3	42	87%	2.1	15	90%	5.2	18	90%	3.3
10832	Frosted Wide												
10833	Wide angle reflector	70	92%	0.73	69	92%	0.71	72	91%	2.2	62	91%	0.7
10834	Elliptical	45 X 10	87%	5.36	44 X 8	87%	6.62	43 X 10	93.3%	6.4	47.5 X 10	88%	4.9
10835	Elliptical Orthogonal*	10 X 47.5	87.6%	4.9	8 X 44	88.%	5.8	9 X 45.5	93%	6.1	10 X 47.4	89%	4.8

*Orthogonal is the elliptical beam turned through 90deg.

#Full Width Half Maximum i.e. total viewing angle

Please note the 10140 does not current fit on a K2



LUXEON® K2 26.5mm range

Part No.	Description	White			Natural White			Red/Amber			Cyan/Green		
		FWHM#	EFF	Cd/lm	FWHM#	EFF	Cd/l _{catlm}	FWHM#	EFF	Cd/lm	FWHM#	EFF	Cd/lm
10048	Plain Tight	6.5	85%	48	7.1	89%	43	6.6	89%	30	6.9	90%	45
10124	Frosted Narrow	7.9	86%	33	5	85%	20	10.2	89%	27	9.4	89%	20
10108	Frosted Medium	18	83%	5.8	21	86%	4.6	19	86%	6	19	85%	4.2
10260	Frosted Wide	33	82%	2.5	32.25	82.6%	2.7	29	87%	3.1	33	81%	2.4
10049	Elliptical	40 x 8.7	89%	7.0	43 x 7.6	86%	7.9	40 x 7.3	86%	10.3	41 x 7.5	87%	7.8
10224	Elliptical Orthogonal*	8.7 x 40	89%	7.0	8.3 x 48	85%	6.9	7.3 x 40	86%	10.3	7.5 x 41	87%	7.8
10234	Elliptical Ramp optic	46 x 7.4	90%	7.5	45 x 7.6	89%	7.9	45 x 7.4	90%	8.7	45 x 7.4	88%	7.8

*Orthogonal is the elliptical beam turned through 90deg.
#Full Width Half Maximum i.e. total viewing angle

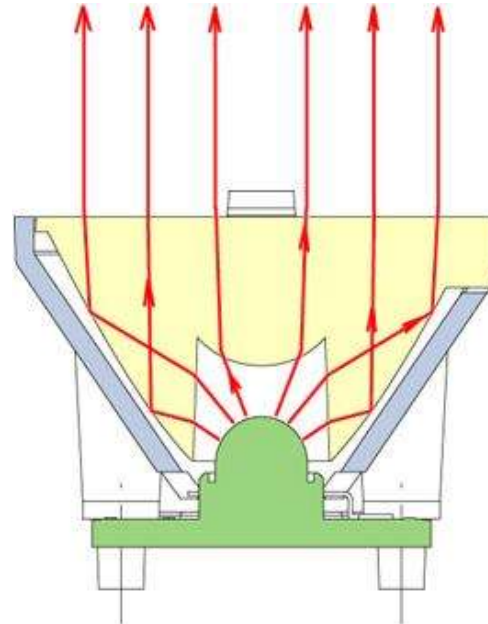

Part No.	Colour	Description
10230	Black	With stake able legs
10231	White	With stake able legs
10232	Black	legs flat on Board
10233	White	legs flat on Board
10256	Black	K2 legged with 2.4 feet
10257	White	K2 legged with 2.4 feet
10258	Black	K2 Legged with 1.2 Feet
10259	White	K2 Legged with 1.2 Feet

LUXEON® K2 26.5mm assembled in holder 10230

Part No.	Description	White			Natural White			Red/Amber			Cyan/Green		
		FWHM#	EFF	Cd/lm	FWHM#	EFF	Cd/l _{cdlim}	FWHM#	EFF	Cd/lm	FWHM#	EFF	Cd/lm
10915	Plain Tight	6.5	85%	48	7.1	89%	43	6.6	89%	30	6.9	90%	45
10916	Frosted Narrow	7.9	86%	33	5	85%	20	10.2	89%	27	9.4	89%	20
10917	Frosted Medium	18	83%	5.8	21	86%	4.6	19	86%	6	19	85%	4.2
10918	Frosted Wide	33	82%	2.5	32.25	82.6%	2.7	29	87%	3.1	33	81%	2.4
10919	Elliptical	40 x 8.7	89%	7.0	43 x 7.6	86%	7.9	40 x 7.3	86%	10.3	41 x 7.5	87%	7.8
10920	Elliptical Orthogonal*	8.7 x 40	89%	7.0	8.3 x 48	85%	6.9	7.3 x 40	86%	10.3	7.5 x 41	87%	7.8
10921	Elliptical Ramp optic	46 x 7.4	90%	7.5	45 x 7.6	89%	7.9	45 x 7.4	90%	8.7	45 x 7.4	88%	7.8

*Orthogonal is the elliptical beam turned through 90deg.

#Full Width Half Maximum i.e. total viewing angle

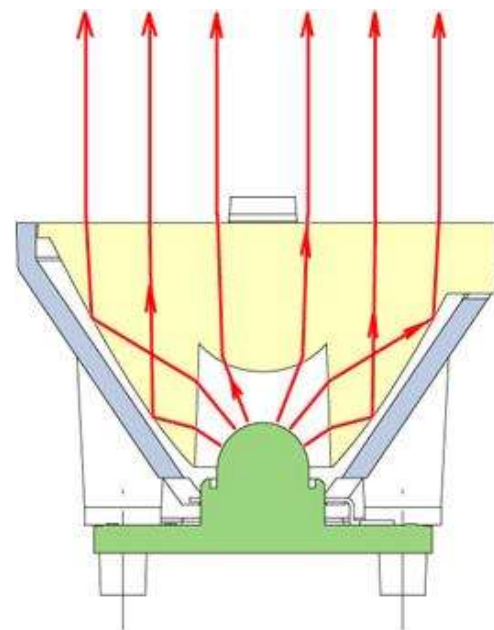

LUXEON® Rebel

10,20,26.5mm Range

“LUXEON® Rebel is the smallest surface mountable power LED available today. With the industry's best lumens per package, highest light density (lumens per mm²), and the highest packing density, LUXEON® Rebel is ideal for both space-constrained and conventional solid-state lighting applications.” Reproduced from Future Lighting Solutions web site



Available from Future Lighting Solutions
www.futurelightingsolutions.com



Carclo Technical Plastics

111 Buckingham Avenue, Slough, Berkshire SL1 4PF ENGLAND / 600 Depot Street Latrobe PA. 15650 USA

Web: www.carclo-optics.com e-mail: sales@carclo-optics.com

Tel UK: 0044 (0) 1753 575011 Tel USA 00 (1) 724 539 6982



LUXEON® REBEL 10mm range

Part No.	Description	White			Neutral White			Red/Amber			Green			Blue		
		FWHM*	EFF	Cd/lm	FWHM*	EFF	Cd/lm	FWHM*	EFF	Cd/lm	FWHM*	EFF	Cd/lm	FWHM*	EFF	Cd/lm
10412	Plain medium Flat front	18.4	85%	6.5	17.8	84%	7.9	16.4	82%	6.3	18.6	84%	7	16.8	84%	6.3
10417	Plain medium Lens front	18.6	83%	8.3	18.25	86%	7.4									
10413	Frosted medium	21.8	84%	4.5	23.2	83%	5.0	21.4	85%	4.2	23.3	81%	5.5	21.9	80%	5.7
10414	Frosted Wide	39.2	78%	1.35	41.4	77%	1.43									
10415	Elliptical	46X19	80%	3.1												

#Full Width Half Maximum i.e. total viewing angle

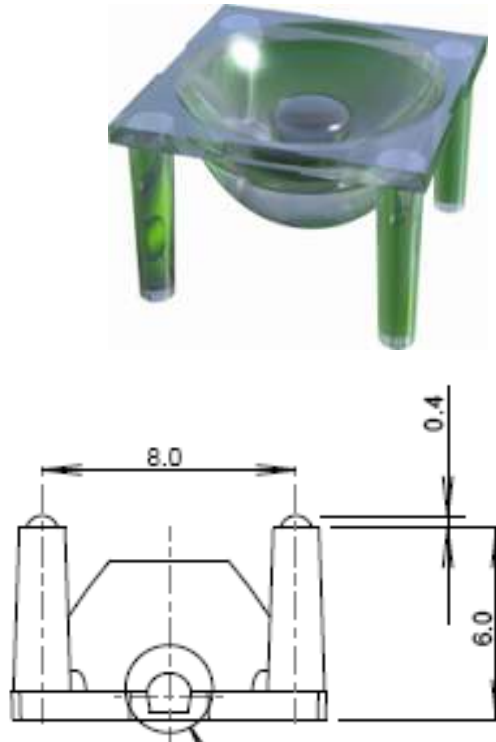
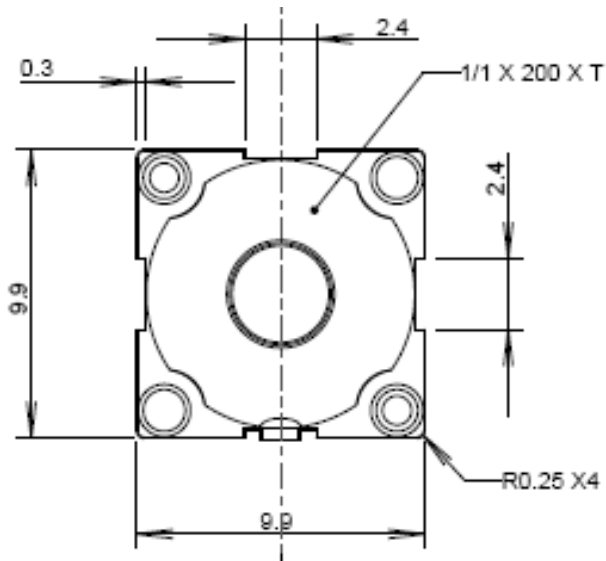

PCB GLUE PAD AND ALIGNMENT HOLE LAYOUT DIMENSIONS

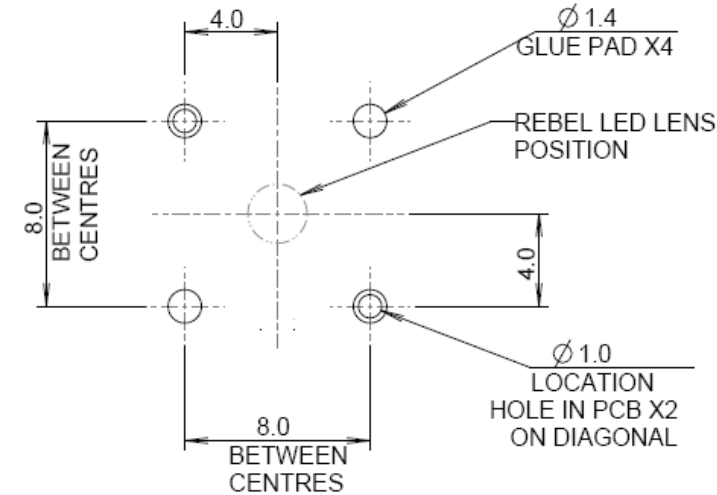

LUXEON[®] REBEL 10mm Triple Optic

Part No.	Description	White			Neutral White			Red/Amber			Green			Blue		
		FWHM*	EFF	Cd/lm	FWHM*	EFF	Cd/lm	FWHM*	EFF	Cd/lm	FWHM*	EFF	Cd/lm	FWHM*	EFF	Cd/lm
10507	Narrow lens front	18	86%	7.1												
10508	Medium Frosted	27	85%	2.8												
10509	Wide Frosted	44	78%	1.24												
10511	Narrow Frosted	22	85%	4.36												

#Full Width Half Maximum i.e. total viewing angle

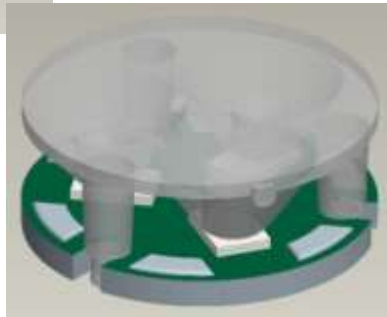
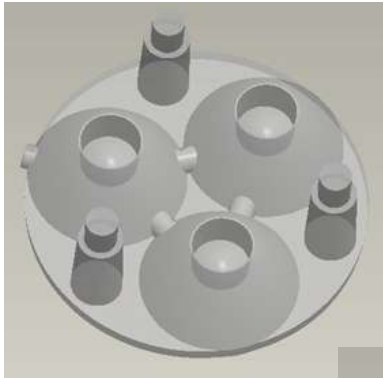

PCB HOLE & GLUE PAD LOCATION

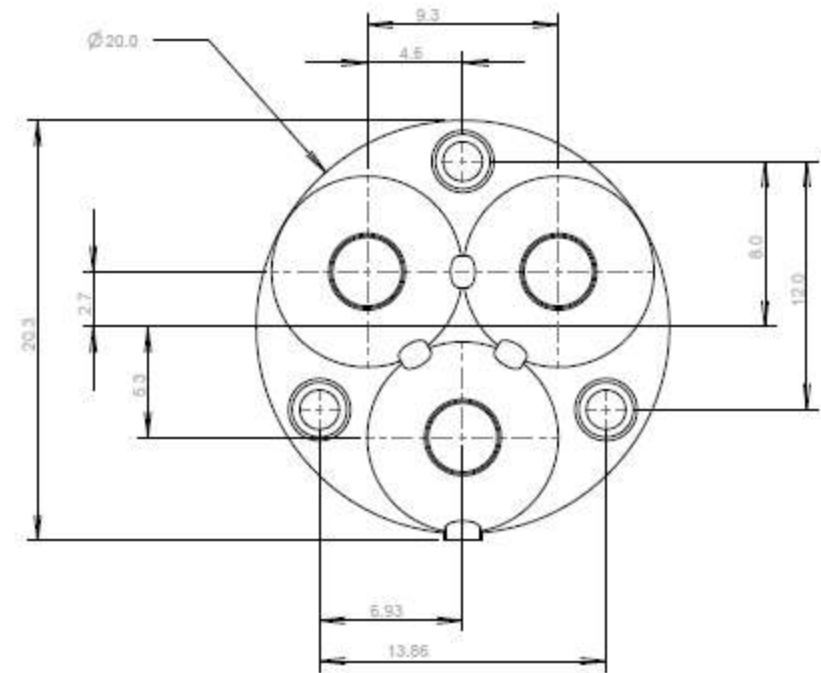
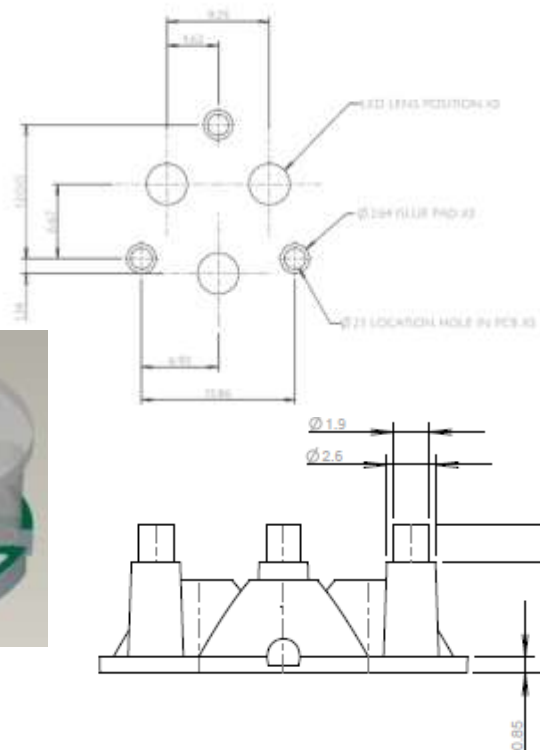

LUXEON[®] REBEL 20mm range

Part No.	Description	White			Natural White			Red/Amber			Green			Blue		
		FWHM#	EFF	Cd/lm	FWHM#	EFF	Cd/lm	FWHM#	EFF	Cd/lm	FWHM#	EFF	Cd/lm	FWHM#	EFF	Cd/lm
10193	Plain Tight	8.7	86%	24	8.4	87.1%	32.5	7	87%	37	6.5	84%	49	6.5	84%	49
10194	Frosted Narrow	12	87%	16	10.65	86.8%	19.4	10.8	88%	19	10	85%	24.3	10	85%	25.4
10208	Ripple Medium	19	83%	6.7	20	86%	6.85	13	81%	11	19	86%	13.8	19	86%	13.8
10195	Medium Frosted	19	83%	5.0	18.1	82.5%	5.8	17	86%	6.3	19	82%	10	19	82%	10
10209	Ripple Wide	24	79%	3.1	37	81.9%	2.6	14	81%	4.9	23	83%	6.3	23	83%	6.3
10196	Wide Frosted	35	74%	2.0	34.1	78.2%	2.2	35	74%	2.0	40	77.5%	3.9	40	78%	3.9
10197	Elliptical	45 x 9.5	82%	6.0	47.8*8.8	84.8%	6	40 x 9.4	84%	7.3	46 x 10	84%	11.7	46 x 10	84%	11.7
10198	Elliptical Orthogonal*	9.5 x 40	81%	6.0	8.95*47.1	85.6%	6.1	9.4 x 40	84%	7.3	10 x 50	85%	10.8	10 X 50	85%	10.8
10356	Fibre	Optimised for coupling into 0.5NA fibre bundles of 8 - 12mm diameter														

*Orthogonal is the elliptical beam turned through 90deg.
#Full Width Half Maximum i.e. total viewing angle

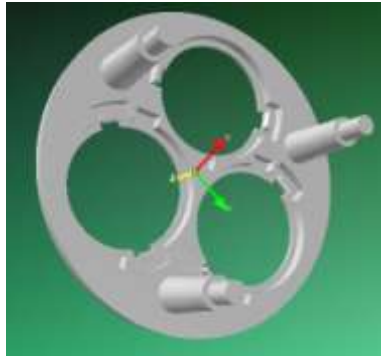

Part No.	Colour	Description	Part No.	Colour	Description
10235	Black	Round Holder	10431	Black	Star Board holder feet
10236	White	Round Holder	10432	Clear	Star Board holder feet
10237	Clear	Round Holder	10433	White	Star Board holder feet
10279	White	50mm Triple holder long leg	10434	Black	Star Board holder no feet
10289	White	50 mm Triple holder short leg	10435	Clear	Star Board holder no feet
10299	Black	50 mm Triple holder Long leg	10436	White	Star Board holder no feet
10309	Black	50 mm Triple holder short leg			

LUXEON[®] REBEL assembled in Holder 10235

Part No.	Description	White			Natural White			Red/Amber			Green			Blue		
		FWHM*	EFF	Cd/lm	FWHM*	EFF	Cd/lm	FWHM*	EFF	Cd/lm	FWHM*	EFF	Cd/lm	FWHM*	EFF	Cd/lm
10845	Plain tight	8.7	86%	24	8.4	87.1%	32.5	7	87%	37	6.5	84%	49	6.5	84%	49
10846	Frosted Narrow	12	83%	16	10.65	86.8%	19.4	10.8	88%	19	10	85%	25	10	85%	25.4
10847	Ripple medium	16	81%	6.6	20	86%	6.85	13	81%	11	19	86%	13.8	19	86%	13.8
10848	Frosted medium	18	83%	5.0	18.1	82.5%	5.8	17	86%	6.3	19	82%	10	19	82%	10
10849	Ripple Wide	22	81%	2.5	37	81.9%	2.6	14	81%	4.9	23	83%	6.3	23	83%	6.3
10850	Frosted Wide	35	74%	2	34.1	78.2%	2.2	35	74%	2	40	77%	3.9	40	78%	3.9
10851	Elliptical	40 X 9.5	81%	6	47.8*8.8	84.8%	6	40 X 9.4	84%	7.3	46 X 10	84%	11.7	46 X 10	84%	11.7
10852	Elliptical Orthogonal*	9.5 X 40	81%	6	8.95*47.1	85.6%	6.1	9.4 X 40	84%	7.3	10 X 46	85%	10.8	10 X 46	85%	10.8

*Orthogonal is the elliptical beam turned through 90deg.
 #Full Width Half Maximum i.e. total viewing angle



LUXEON® Rebel 26.5mm Optics

Part No. Optics on their own	Description	White			Red			Blue			Green		
		FWHM	EFF	Cd/lm	FWHM	EFF	Cd/lm	FWHM	EFF	Cd/lm	FWHM	EFF	Cd/lm
10048	Plain tight												
10124	frosted narrow												
10108	Frosted medium												
10260	Frosted Wide												
10049	Elliptical												
10224	Elliptical Orthogonal												
10234	Elliptical Ramp Optic												

Part No.	Colour	Description
10440	White	4.3mm foot
10450	White	2.0mm foot
10460	White	0.8mm foot
10470	Black	4.3mm foot
10480	Black	2.0mm foot
10490	Black	0.8mm foot

*Orthogonal is the elliptical beam turned through 90deg.
#Full Width Half Maximum i.e. total viewing angle

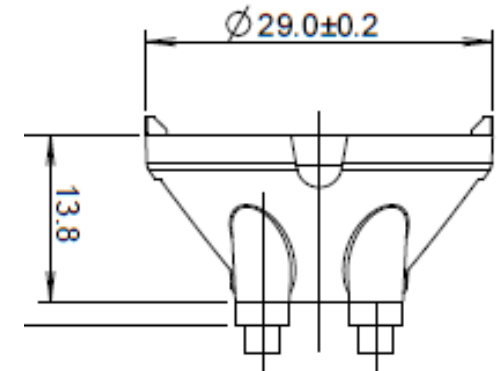
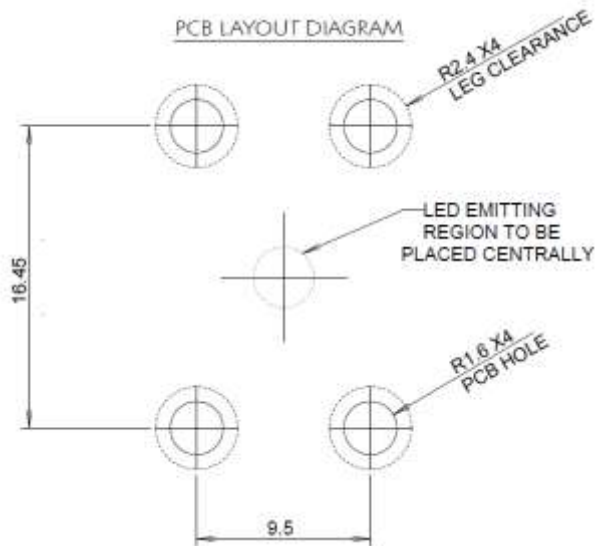

LUXEON®

Other Optics

Here are further range's of different optics that suit some of the different LUXEON® LED's please look for the correct part number for the LED of your choice



Available from Future Lighting Solutions
www.futurelightingsolutions.com

Carclo Technical Plastics

111 Buckingham Avenue, Slough, Berkshire SL1 4PF ENGLAND / 600 Depot Street Latrobe PA. 15650 USA

Web: www.carclo-optics.com e-mail: sales@carclo-optics.com

Tel UK: 0044 (0) 1753 575011 Tel USA 00 (1) 724 539 6982



Other Optics for the LUXEON® range

Part No.	Description	White			Neutral White			Warm White			Red/Amber			Cyan/Green		
		FWHM#	EFF	Cd/lm	FWHM#	EFF	Cd/lm	FWHM#	EFF	Cd/lm	FWHM#	EFF	Cd/lm	FWHM#	EFF	Cd/lm
10025	50mm Optic LUXEON® I	3.0	74%	145	N/A	N/A	N/A	7.0	76%	91	4.6	80%	72	4.9	72%	60.3
10025	50mm Optic LUXEON®III	3.0	75%	89	N/A	N/A	N/A	N/A	N/A	N/A	5	80%	46	3.9	73%	96
10025	50mm Optic LUXEON®V	6.2	73%	35	N/A	N/A	N/A	N/A	N/A	N/A	N/A	N/A	N/A	6.4	67%	24
10144	60mm Optic LUXEON®I	3.8	81%	145	N/A	N/A	N/A	2.7	88%	92	3.0	84%	136	2.9	80%	222
10144	60mm Optic LUXEON®III	3.2	82%	74	N/A	N/A	N/A	N/A	N/A	N/A	5	81%	79	3.1	71%	221
10144	60mm Optic LUXEON®V	6.0	82%	37	N/A	N/A	N/A	N/A	N/A	N/A	N/A	N/A	N/A	7	75%	34
10144	60mm Optic LUXEON®K2	3.1	77%	187	3.2	80%	181	2.9	80%	189.9	3	83%	209	3.1	78%	169
10144+10145	60mm Optic LUXEON®I	38 X 3	79%	17	N/A	N/A	N/A	37 X 3	79%	10.6	37 X 3	80%	15.6	38 X 3	79%	14.5
10144+10145	60mm Optic LUXEON®III	38 X 3	80%	15	N/A	N/A	N/A	N/A	N/A	N/A	38 X 5	76%	10.1	38 X 3	73%	16.5
10144+10145	60mm Optic LUXEON®V	37 X 6	78%	7.5	N/A	N/A	N/A	N/A	N/A	N/A	N/A	N/A	N/A	38 X 7	73%	7.1
10144+10145	60mm Optic LUXEON®K2	38 X 3.1	73%	14.5	38 X 3	75%	14.6	38x2.4	75%	16	38 X 3	79%	16.5	38 X 3	74%	13.8

#Full Width Half Maximum i.e. total viewing angle



- We have a holder Part number 10146 which holds the optic 10144 and the spreader lens 10145 in the correct place
- This can be brought as a built up assembly of Optic 10144 and holder 10146 under part number 10147
- New Part 10158 is the same beam angle as the 10144 and the look is the same but due to using a AL coating the efficiency is reduced by about 8% but with big part price savings



LUXEON®

Side Emitter Range

Here is a range's of optics that convert the standard different LUXEON® LED's into side emitting units please look for the correct part number for the LED of your choice



Available from Future Lighting Solutions
www.futurelightingsolutions.com

Carclo Technical Plastics

111 Buckingham Avenue, Slough, Berkshire SL1 4PF ENGLAND / 600 Depot Street Latrobe PA. 15650 USA

Web: www.carclo-optics.com e-mail: sales@carclo-optics.com

Tel UK: 0044 (0) 1753 575011 Tel USA 00 (1) 724 539 6982



Side Emitters for LUXEON® LED's

Part No.	Description	White			Natural White			Warm White			Red/Amber			Cyan/Green		
		FWHM#	EFF	Cd/lm	FWHM#	EFF	Cd/lm	FWHM#	EFF	Cd/lm	FWHM#	EFF	Cd/lm	FWHM#	EFF	Cd/lm
10071	LUXEON® I Star				N/A	N/A	N/A									
10040	LUXEON® III Star				N/A	N/A	N/A	N/A	N/A	N/A						
10040	LUXEON® V Star				N/A	N/A	N/A	N/A	N/A	N/A	N/A	N/A	N/A			
10099	LUXEON® I/flat base				N/A	N/A	N/A									
10099	LUXEON® III flat base				N/A	N/A	N/A	N/A	N/A	N/A						
10099	LUXEON® V flat base				N/A	N/A	N/A	N/A	N/A	N/A	N/A	N/A	N/A			
10126	LUXEON® K2															
10267	LUXEON® Rebel	8.4	87%	0.8												

#Full Width Half Maximum i.e. total viewing angle

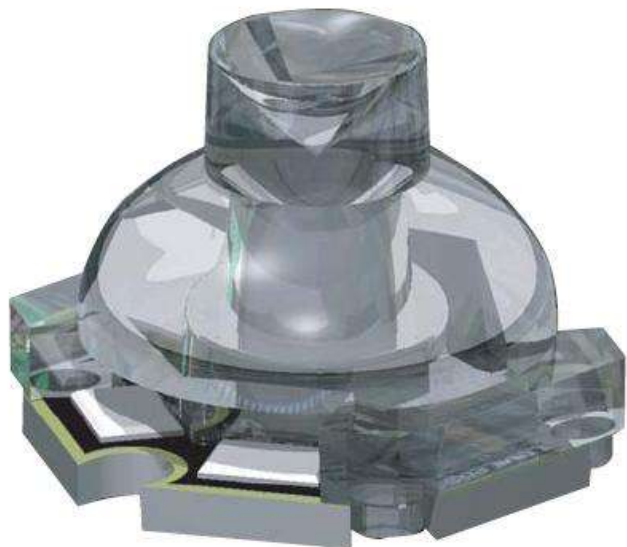

Side-Emitting Optic

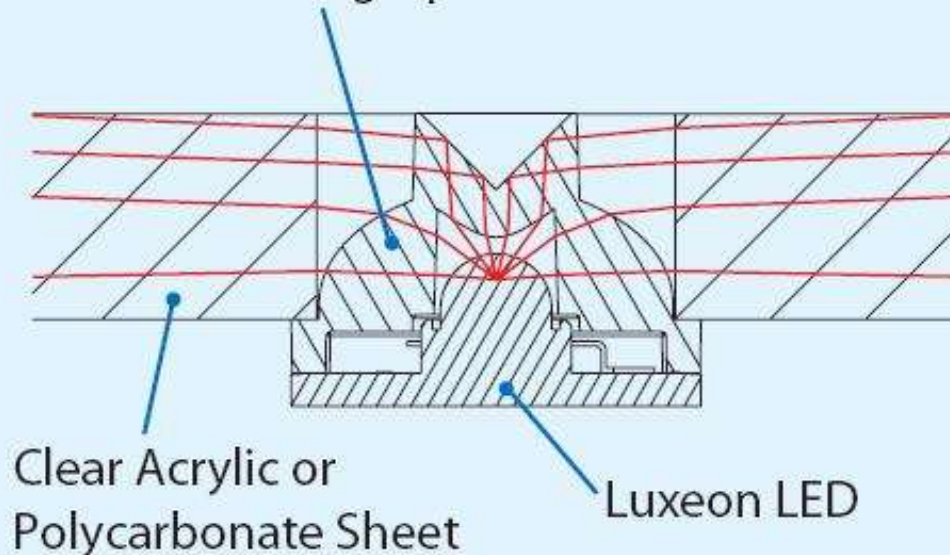

Side Emitter 10267 Rebel

FWHM divergence versus side emitter rotation angle

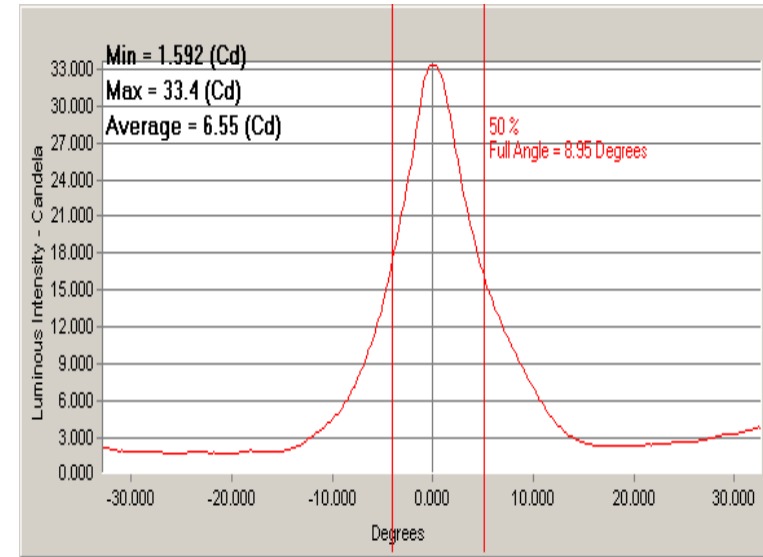
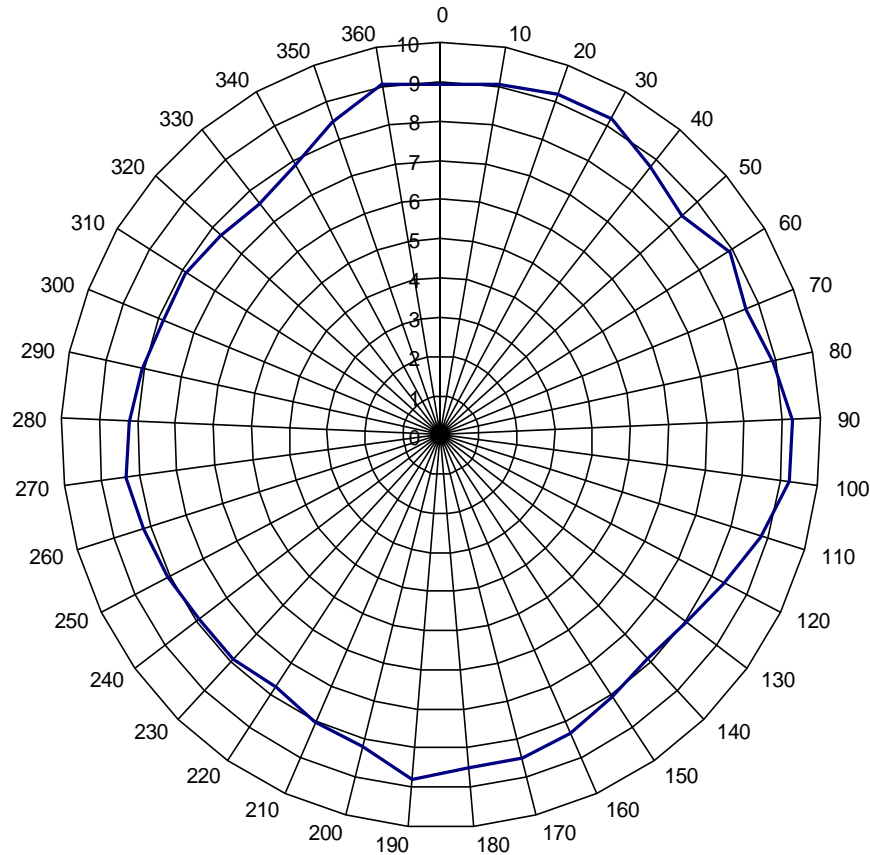

FWHM:

Average FWHM: 8.4degree;

Minimum FWHM: 7.45degree ;

Maximum FWHM: 9.3degree

Efficiency : 87%

Cd/lm: $38/46=0.8$ @ 350mA (average of 8 readings)



Continuous Strip Optic

Here is a optic to fit over a linear strip of LED's to give good even mix along the length whilst controlling the beam in the other direction designed for LUXEON® Rebel



Available from Future Lighting Solutions
www.futurelightingsolutions.com

Carclo Technical Plastics

111 Buckingham Avenue, Slough, Berkshire SL1 4PF ENGLAND / 600 Depot Street Latrobe PA. 15650 USA

Web: www.carclo-optics.com e-mail: sales@carclo-optics.com

Tel UK: 0044 (0) 1753 575011 Tel USA 00 (1) 724 539 6982

Continuous Strip Optic

- A single piece optic that can be made in lengths to suit your needs
- Will be standard in 1.2m (4') and 300mm (1') lengths tol -0.0 /+3.0
- Easily cut to your required length using a fine tooth saw
- Made from optical quality PC for optimal temperature and system performance
- Designed for the Rebel
- Surface mount height tolerance less critical due to diffused front optical surface
- Variable beam angles to mounting heights as show in the table below based on Rebel LED

Z height from Package	FWHM	Eff
0 mm	38	85%
0.5 mm	34	81%
1 mm	30.7	75.5%

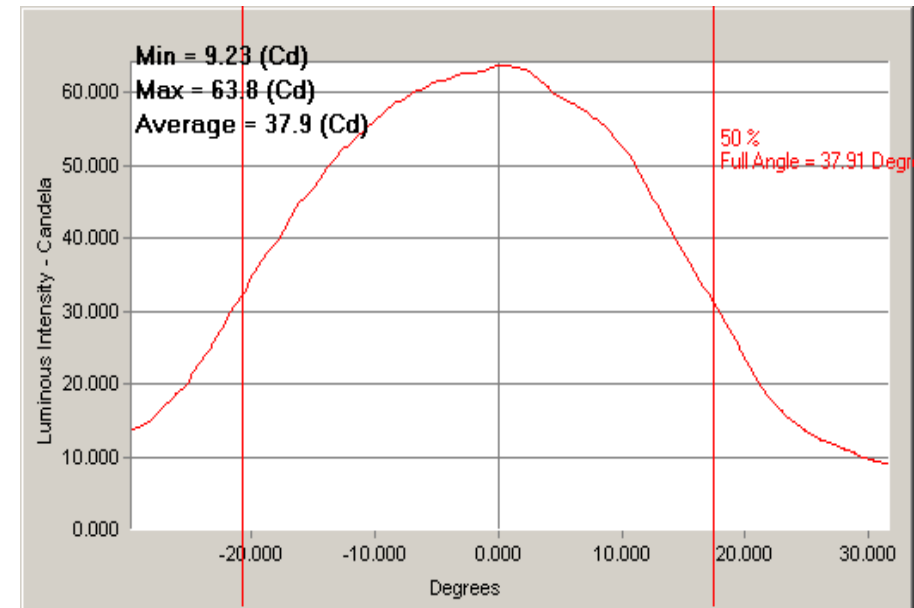
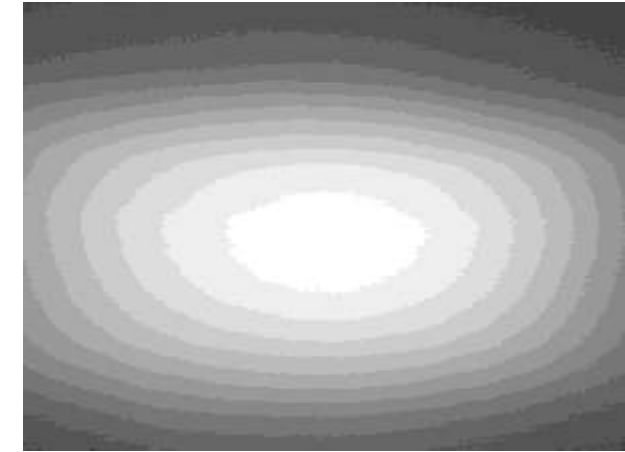
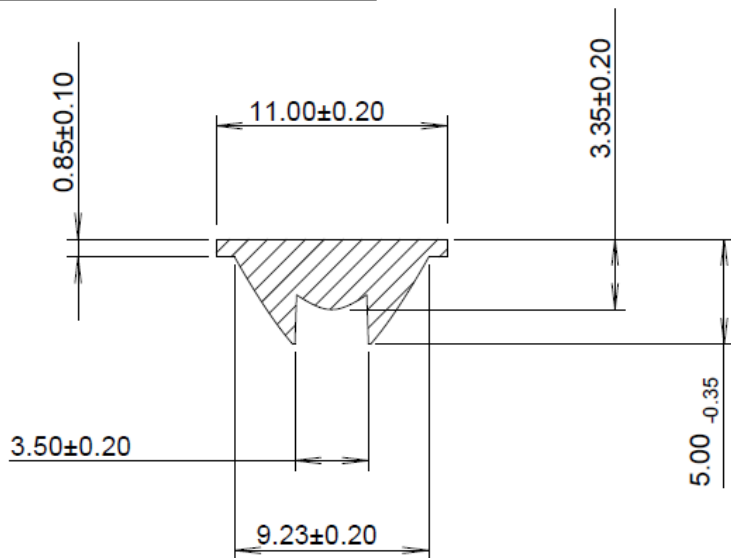
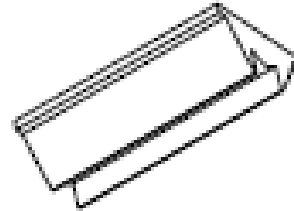

Application notes

- Two-part epoxies such as Loctite 3430 can be used to join or mount the continuous strip optic without fogging the PC lens
- Ideal for florescent tube replacement fixtures, refrigeration lighting, cove lighting, under cupboard lighting, retail lighting, wall washing, and other general illumination applications, in both single colour as well as RGB mixing.
- Colour binning LED's less critical in most applications as the light is mixed in the long plane.
- Easily mounted in an extruded aluminium housing that can serve as both a heat sink as well as a base unit for a light fixture or a light engine module

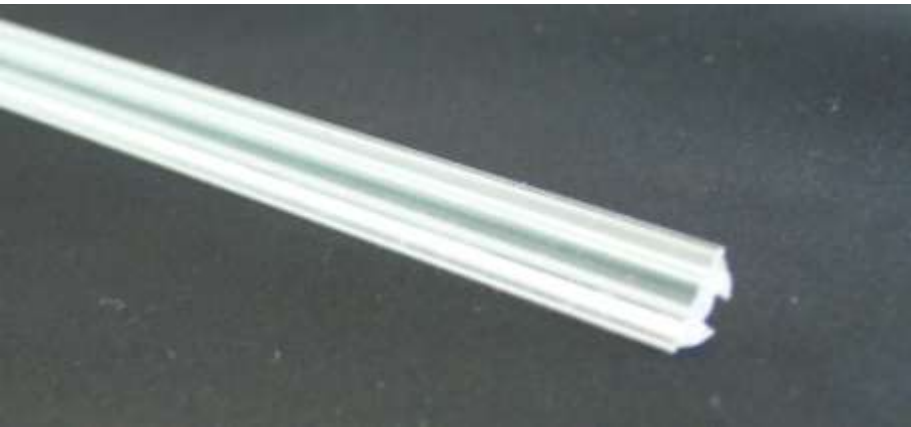

Part no	Description
10397	1.2m, (4 foot) Long
10398	300mm, (1 foot) Long

STRIP OPTIC MOUNTING DIMENSIONS

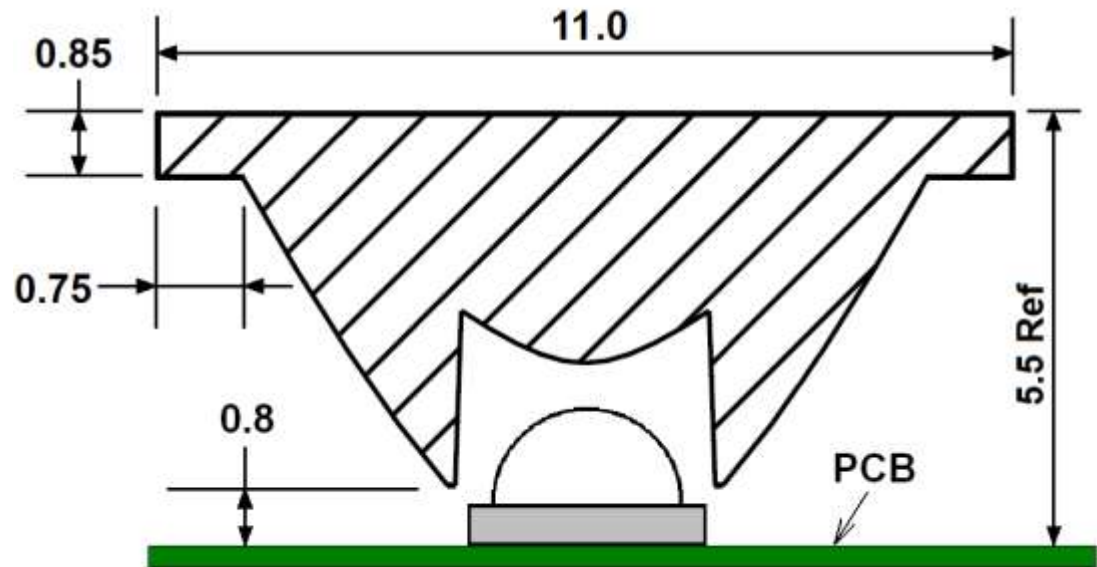

Bubble Optics

Ultra wide

This is a new design and the start of our range of 'Bubble Optics' these optics produce a very wide but even beam on a flat surface idea for wide area lighting designed for the LUXEON® Rebel and K2



Available from Future Lighting Solutions
www.futurelightingsolutions.com

Carclo Technical Plastics

111 Buckingham Avenue, Slough, Berkshire SL1 4PF ENGLAND / 600 Depot Street Latrobe PA. 15650 USA

Web: www.carclo-optics.com e-mail: sales@carclo-optics.com

Tel UK: 0044 (0) 1753 575011 Tel USA 00 (1) 724 539 6982



Ultra Wide Angle Optics

Optics for Producing uniform illuminance over wide areas

Carclo Ultra Wide Angle Optics are designed to meet the needs of Luminaire designers who need to efficiently light wide areas with very even illumination. These optics are suitable for applications such as emergency lighting, parking facility illumination and many other general illumination areas.

These optics work by re-mapping the light output from the Led to the far-field. Their hemi-spherical outer shape has given rise to their generic name “Bubble optics”.

Mounted at 2.5m (~8 ft.) the 120° optic will evenly illuminate an area 8m (~26 ft.) in diameter, the 130° optic will illuminate a 10m (~33 ft.) diameter.

Features

- Beam widths of 120 deg FWHM (Part No. 10403) and 130 deg FWHM (Part No. 10406)
- Greater than 90% efficiency.
- Optimised for Led's with Lambertian 1.5 x 1.5 mm emitting area.
- One piece design for small footprint LED's like the Rebel, Cree XP, Nichia 036 and others.
- Additional holders available for use with taller led types such as Seoul P4 and K2 Led's.
- Manufactured in lens grade polycarbonate with UL certification.
- Suitable for continuous operation up to 120 °C.

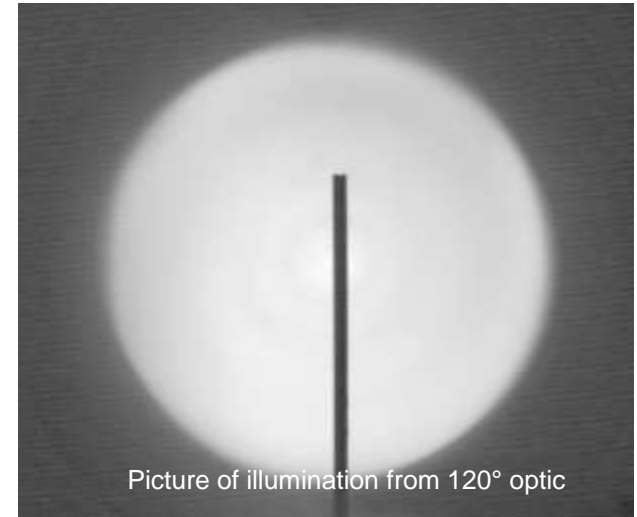

Application notes

- Arrays of 19.7mm diameter Ultra wide optics should be placed no closer than 27mm between centres to avoid shading.
- Locate on PCB using 2x $\varnothing 2.5$ mm holes equi-spaced 7mm either side of Led emitting area.
- Always use a very low vapour adhesive such as Loctite 3430 when mounting polycarbonate optics.

LED	120 deg	130 deg	Holder
Rebel	10403	10406	not needed
K2	10403	10406	10381

