



Sigma II Servo System Product Catalog Supplement

Product Overview.....	2 ~ 7
-----------------------	-------

100/200V Single-phase Sigma II Servo System

SGMAH Sigma II Servo System.....	9 ~ 25
SGMPH Sigma II Servo System.....	27 ~ 43
SGMPH Sigma II Gearmotor System.....	45 ~ 54
SGDH Sigma II Servo Amplifier.....	95 ~ 123

200V Three-phase Sigma II Servo System







SGMGH Sigma II Servo System	55 ~ 66
SGMGH Sigma II Gearmotor System.....	67 ~ 81
SGMSH Sigma II Servo System.....	83 ~ 93
SGDH Sigma II Servo Amplifier.....	95 ~ 123

400V Three-phase Sigma II Servo System

SGMGH Sigma II Servo System	125 ~ 136
SGMSH/UH Sigma II Servo System.....	137 ~ 149
SGMBH Sigma II Servo System.....	151 ~ 162
SGDH Sigma II Servo Amplifier.....	163 ~ 199

Product Overview

Yaskawa has a full lineup of servomotors and amplifiers. Choose the best drives for your needs and specifications.

Servomotor										
Series		Description	Applications							
Small capacity	SGMAH (3000rpm/5000rpm max) 	High Speed Series Large torque required at low inertia.	Chip Mounters	PCB Drilling Machines	Packaging Machines	Robots	Material Handling Equipment			
	SGMPH (3000rpm/5000rpm max) 	Flat Series Short L-length. Good for installation in compact spaces.								
Medium capacity	SGMGH (1500rpm/3000rpm max) 	General Purpose High speed rotation required without load.							Machine Tool Feeds	
	SGMSH (3000rpm/5000rpm max) 	High Speed Series High torque required at low inertia.	Chip Mounters	PCB Drilling Machines						
	SGMUH (6000rpm max) 	High Speed Series High torque at 6000rpm.								
Large capacity	SGMBH (2000rpm max) 	Large kW	Thermoforming	Converting				Injection molding		

Servomotor		Servo Amplifier Type SGDH-***				Page
Peak Torque	Capacity	110V	230V		480V	
		Single-phase	Single-phase	Three-phase	Three-phase	
up to 1,010oz • in	30W	A3BE	A3AE	—	—	11, 97
	50W	A5BE	A5AE	—	—	
	100W	01BE	01AE	—	—	
	200W	02BE	02AE	—	—	
	400W	—	04AE	—	—	
	750W	—	08AE-S	—	—	
up to 2,027oz • in	100W	01BE	01AE	—	—	29, 97
	200W	02BE	02AE	—	—	
	400W	—	04AE	—	—	
	750W	—	08AE-S	08AE	—	
	1500W	—	15AE-S	15AE	—	
up to 1,988in • lb	0.45kW	—	—	05AE	05DE	57, 97, 127, 153
	0.85kW	—	—	10AE	10DE	
	1.3kW	—	—	15AE	15DE	
	1.8kW	—	—	20AE	20DE	
	2.9kW	—	—	30AE	30DE	
	4.4kW	—	—	50AE	50DE	
	5.5kW	—	—	60AE	60DE	
	7.5kW	—	—	75AE	75DE	
	11kW	—	—	1AAE	1ADE	
	15kW	—	—	1EAE	1EDE	
up to 422in • lb	1.0kW	—	—	10AE	10DE	85, 97, 139, 153
	1.5kW	—	—	15AE	15DE	
	2.0kW	—	—	20AE	20DE	
	3.0kW	—	—	30AE	30DE	
	4.0kW	—	—	50AE	50DE	
	5.0kW	—	—	50AE	50DE	
up to 190in • lb	1.0 kW	—	—	—	10DE	139, 153
	3.0kW	—	—	—	30DE	
up to 6120in • lb	22kW	—	—	—	2BDE	153, 165
	30kW	—	—	—	3ZDE	
	37kW	—	—	—	3GDE	
	45kw	—	—	—	4EDE	
	55kW	—	—	—	5EDE	

Product Overview

Single-phase 30W to 1500W (230VAC)

Molded-case Circuit Breaker (MCCB)

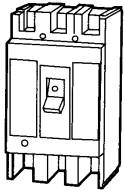

Protects the power line by shutting the circuit OFF when overcurrent is detected.

Noise Filter (optional)

Used to eliminate external noise from the power line.

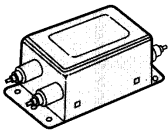

Magnetic Contactor

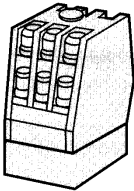

Turns the servo ON and OFF. Install a surge suppressor on the magnetic contactor.

Holding Brake Power Supply

(customer supplied)
Used only for SGM* servomotor with a holding brake.

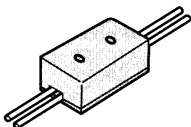

Power Supply
Single-phase, 230VAC

Molded-case
Circuit Breaker

Noise
Filter

Magnetic
Contactor

Brake
Power
Supply

Magnetic
Contactor

Required for servomotor
with a brake.

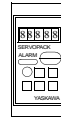

Digital Operator
(Type JUSP-OP02A-1)



Personal
Computer

Cable for
connecting to
servo amplifier
required.

Host Controller

Connect the SGD servo amplifier to a Yaskawa host controller or one made by other vendors. (Analog input, pulse train input available)



SGDH
Servo Amplifier
Type SGDH-A3AE
to -15AE-S



SGMPH Servomotor

Three-phase 0.5kW to 15kW (230VAC)

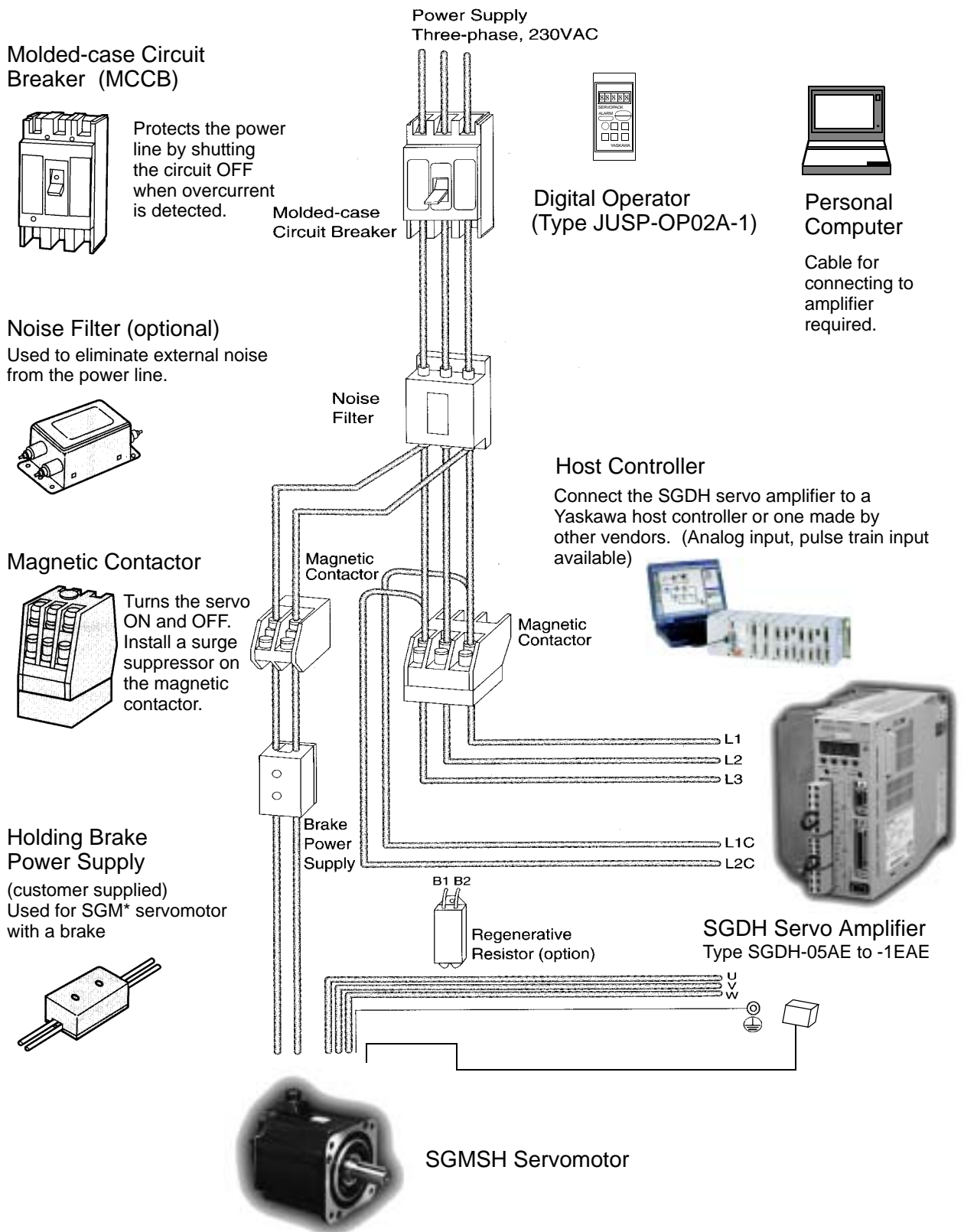

Three-phase 0.5kW to 55kW (480VAC)

Molded-case Circuit Breaker (MCCB)

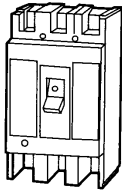

Protects the power line by shutting the circuit OFF when overcurrent is detected.

Molded-case Circuit Breaker

Noise Filter (optional)

Used to eliminate external noise from the power line.

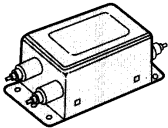

Noise Filter

Magnetic Contactor

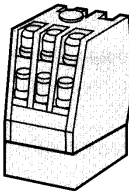

Turns the servo ON and OFF. Install a surge suppressor on the magnetic contactor.

Magnetic Contactor

Power Supply
Three-phase, 480VAC

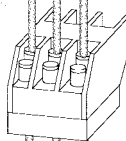
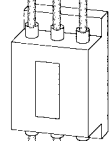
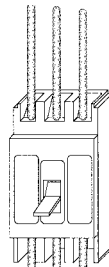

Control Power Supply

24V

0V

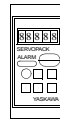
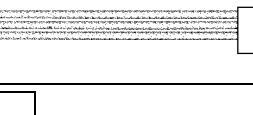

Digital Operator
(Type JUSP-OP02A-1)



Personal Computer

Cable for connecting to amplifier required.

Host Controller

Connect the SGD servo amplifier to a Yaskawa host controller or one made by other vendors. (Analog input, pulse train input available)



MP920



SGDH Servo Amplifier
Type SGDH-05DE to -5EDE



SGMGH Servomotor

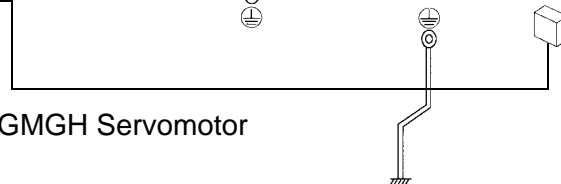

Selecting Your Sigma Servo System

For your convenience, each motor series in this selection guide includes a diagram to help you select and identify the components necessary for your system. Each item is letter-coded and cross-referenced in the option tables on the following pages.

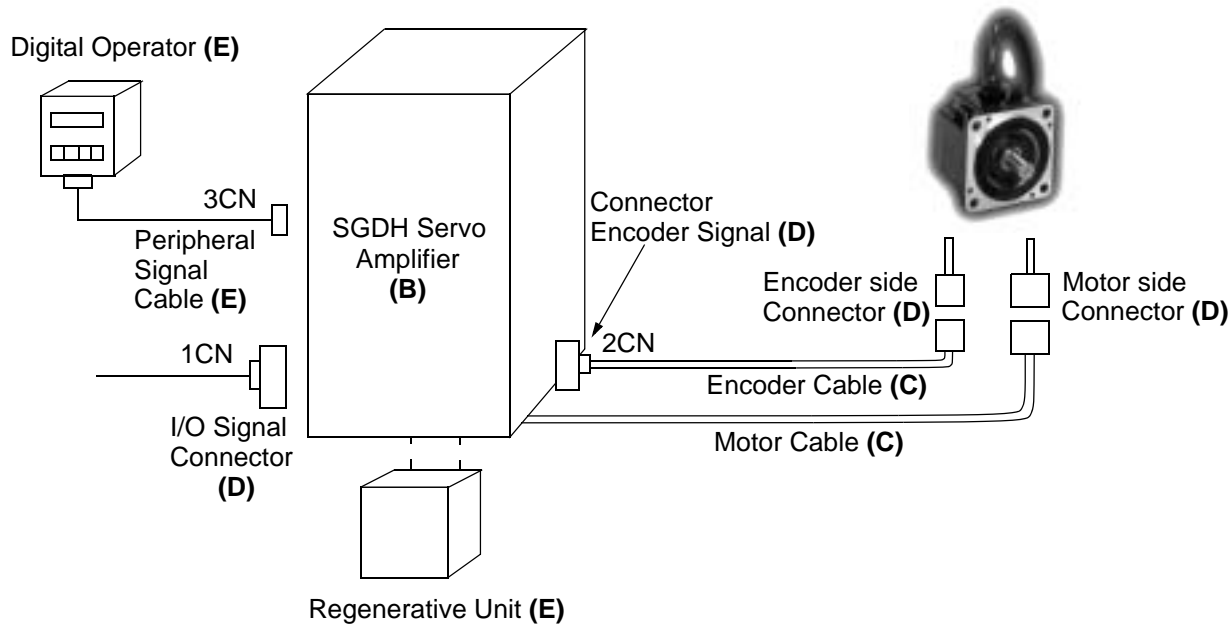

1. First, select the **Sigma servomotor** suited for your application using the Yaskawa Servomotor Sizing Software or the Sigma Servomotor Data Sheets. Using the tab indicators in this guide, locate the section describing the type of servomotor you selected.
2. Then select a compatible **amplifier** using the Sigma II Servo Amplifier Selection Table in the appropriate servomotor section of this guide.
3. Yaskawa offers **pre-wired power and encoder cables** with correctly matched, high quality connectors attached to permit correct interconnection. Refer to the Pre-wired Cable Selection Table to select the correct cable assembly from the list of standard cable lengths.
4. Solder-type **connectors** without cables are also available. Refer to the appropriate Servomotor Connector Selection Table to select the connector kit to be used with the selected servomotor or encoder (with or without brake).
5. Refer to the Peripheral Device Selection Table to select **peripheral equipment** to be used with the servo amplifier (i.e., digital operator, regenerative unit, software, etc.).
6. Specify technical product manual YEA-SIA-S800-32.2 on your Sigma II Servo System purchase order. One manual is available at no charge with each purchase order. The manual can also be downloaded at no charge from Yaskawa's Web site at www.yaskawa.com.

Each table includes a column labeled "Item Class," which classifies the availability of the specified option. Following are descriptions of the codes used:

Stock: Normally 3 to 5 days lead time for most order quantities. 3 to 5 weeks maximum if temporary outages occur. For critical lead times or requirements for larger quantity shipments, check with your Yaskawa inside sales representative.

Limited Stock: Typically, small quantities are available from stock. These items will likely change to stock items as the order demand increases. For critical lead times or requirements for larger quantity shipments, check with your Yaskawa inside sales representative.

Non-Stock: Normal delivery: 12 to 16 weeks.

NOTES:

Super High Power Rate Series SGMAH Servomotors - With Incremental / Absolute Encoder

Rated Output: 30W, 50W, 100W,
200W, 400W, 750W



For Additional Information	Page(s)
SGMAH Ratings & Specifications	12
SGMAH Speed/Torque Curves	13
SGMAH Dimensions	14 - 22
SGMAH Selection/Ordering Information	23 - 27
SGDH Ratings & Specifications	99 - 100
SGDH Dimensions	101 - 112

Design Features

1. Compact

- Small sized motor
Five frame sizes (including NEMA 23 and 34 flanges): up to 1,010oz •in peak torque
Smaller installation space for more compact machine designs.

2. High Speed

- High power rating
High power is achieved by minimizing the inertia of the motor
This increases the acceleration/deceleration rate and reduces positioning time
- Maximum rotation speed of 5000rpm
Increases maximum rotation speed and shortens positioning time
- Rated speed of 3,000rpm

3. Encoders (reduced wiring serial encoder)

- 13-bit (2048 ppr x 4) incremental encoder (standard)
- 16-bit (16384) absolute encoder (option)

4. Enclosure

- Totally enclosed, self-cooled IP55 (not including shaft)
- Optional shaft seals are available.

5. Application Emphasis

- Compact, high torque to inertia ratio
- Chip mounters
- PCB drilling machines
- Robots
- Conveyors
- Packaging

6. Low Noise

- Adopting the IGBT power element eliminates irritating “metallic” sounds

7. Certified International Standards

- UL, cUL recognized (File #: E165827), CE compliance

Servomotor Ratings and Specifications

Time Rating:	Continuous	Enclosure:	Totally-enclosed, self-cooled	Excitation:	Permanent magnet
Insulation:	Class B	Ambient Temperature:	0 to 40°C	Drive Method:	Direct drive
Vibration:	15µm or less	Ambient Humidity:	20 to 80%	Mounting:	Flange-mounted
Withstand Voltage:	1500V _{ac}		(non-condensing)	Applicable Encoder:	13-bit incremental or 16-bit absolute encoder
Insulation Resistance:	10MΩ minimum at 500V _{DC}	Rated Rotation Speed:	3000rpm		
		Maximum Rotation Speed:	5000rpm		

Specifications are the same for either absolute or incremental encoders.

System Voltage	MOTOR SGMAH-	Rated Output	Rated Torque*		Instantaneous Peak Torque*		Continuous Rated Current	Maximum Peak Current	Rated Angular Acceleration	Rated Power Rate*
		W (hp)	oz • in	N • m	oz • in	N • m	A _{rms}	A _{rms}	rad/s ²	kW/s
100V _{ac}	A3B	30 (0.04)	13.5	0.095	40.5	0.29	0.66	2.0	57500	3.49
	A5B	50 (0.07)	22.6	0.159	67.7	0.48	0.95	2.9	72300	11.5
	01B	100 (0.13)	45.1	0.318	135	0.96	2.4	7.2	87400	27.8
	02B	200 (0.27)	90.1	0.637	270	1.91	3.0	9.0	60100	38.2
	04A**	400 (0.53)	181	1.27	542	3.82	2.8	8.5	73600	93.7
200V _{ac}	A3A	30 (0.04)	13.5	0.095	40.5	0.29	0.44	1.3	57500	5.49
	A5A	50 (0.07)	22.6	0.159	67.7	0.48	0.64	2.0	72300	11.5
	01A	100 (0.13)	45.1	0.318	135	0.96	0.91	2.8	87400	27.8
	02A	200 (0.27)	90.1	0.637	270	1.91	2.1	6.5	60100	38.2
	04A	400 (0.53)	181	1.27	542	3.82	2.8	8.5	73600	93.7
	08A	750 (1.01)	338	2.39	1010	7.1	4.4	13.4	35600	85.1

* Values when the servomotor is combined with an SGD servo amplifier.

** When combined with an SGD-04FE servo amplifier.

System Voltage	MOTORS SGMAH-	Moment of Inertia				Holding Brake (at 20°C)				Allowable Load Inertia*
		Motor without Brake		Motor with Brake		Capacity	Torque	Coil Resistance	Rated Current	
		oz • in • s ² × 10 ⁻³	kg • m ² × 10 ⁻⁴	oz • in • s ² × 10 ⁻³	kg • m ² × 10 ⁻⁴					
100V _{ac}	A3B	0.235	0.0166	0.355	0.251	6	2.0	96	0.25	0.63
	A5B	0.312	0.0220	0.432	0.0305	6	2.0	96	0.25	0.78
	01B	0.515	0.0364	0.635	0.0449	6	3.5	96	0.25	1.20
	02B	1.50	0.106	2.321	0.164	6.5	15	89	0.27	3.69
	04A	2.45	0.173	3.271	0.231	6.5	15	89	0.27	3.82
200V _{ac}	A3A	0.235	0.0166	0.355	0.0251	6	2.0	96	0.25	0.63
	A5A	0.312	0.0220	0.432	0.0305	6	2.0	96	0.25	0.78
	01A	0.515	0.0364	0.635	0.0449	6	3.5	96	0.25	1.20
	02A	1.50	0.106	2.321	0.164	6.5	15	89	0.27	3.69
	04A	2.45	0.173	3.271	0.231	6.5	15	89	0.27	3.82
	08A	9.52	0.671	11.5	0.811	6	25	96	0.25	13.4

* Values apply to motors without brake.

• J_L (allowable load inertia) shows the range requiring no exterior regenerative unit. When these values are exceeded, application may be restricted or a regenerative unit may be required.

Speed / Torque Curves

200V

SGMAH-A3A

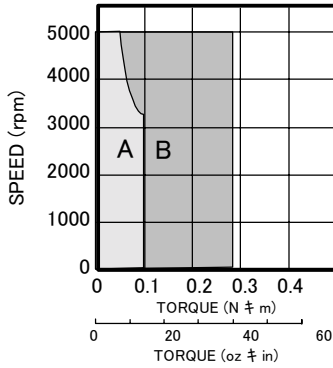

SGMAH-A5A

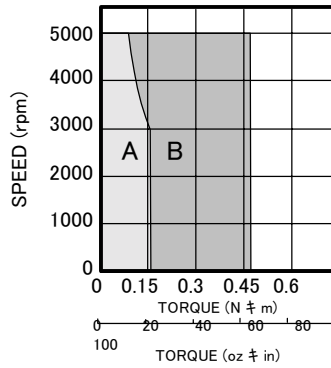

SGMAH-01A

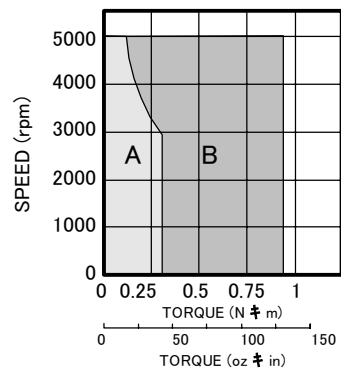

SGMAH-02A

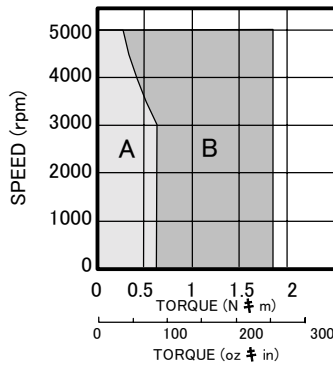

SGMAH-04A

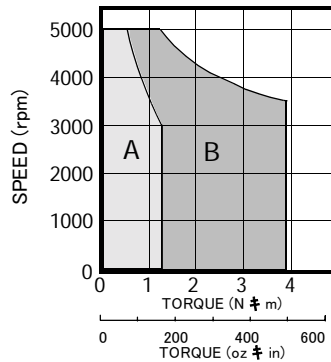

SGMAH08A

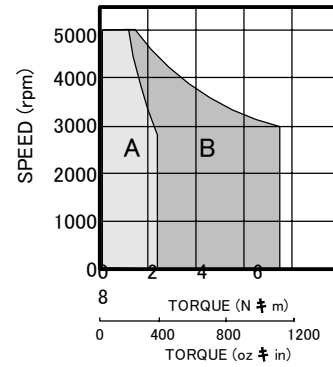

100V

SGMAH-A3B

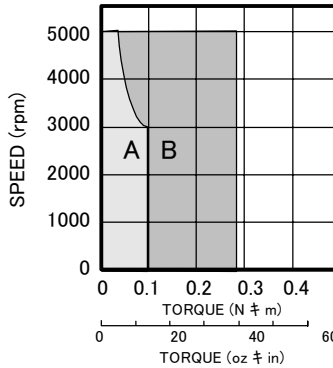

SGMAH-A5B

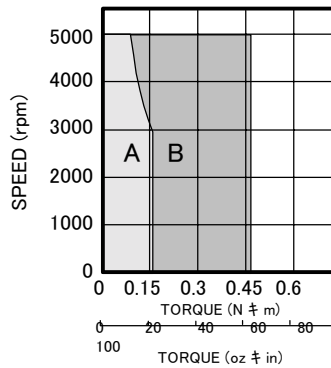

SGMAH-01B

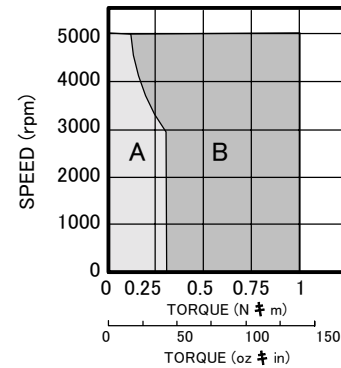

SGMAH-02B

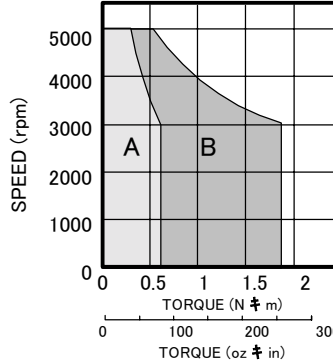

SGMAH-04A*

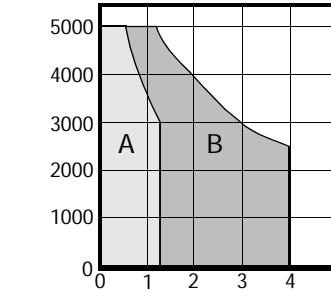

A : CONTINUOUS DUTY ZONE

B : INTERMITTENT DUTY ZONE

* When combined with SGD4 FE amp.

Dimensions in inches (mm)

(1) 13-Bit Incremental or 16-Bit Absolute Encoder, without Brake

- 30W (0.04hp), 50W (0.07hp), 100W (0.13hp)

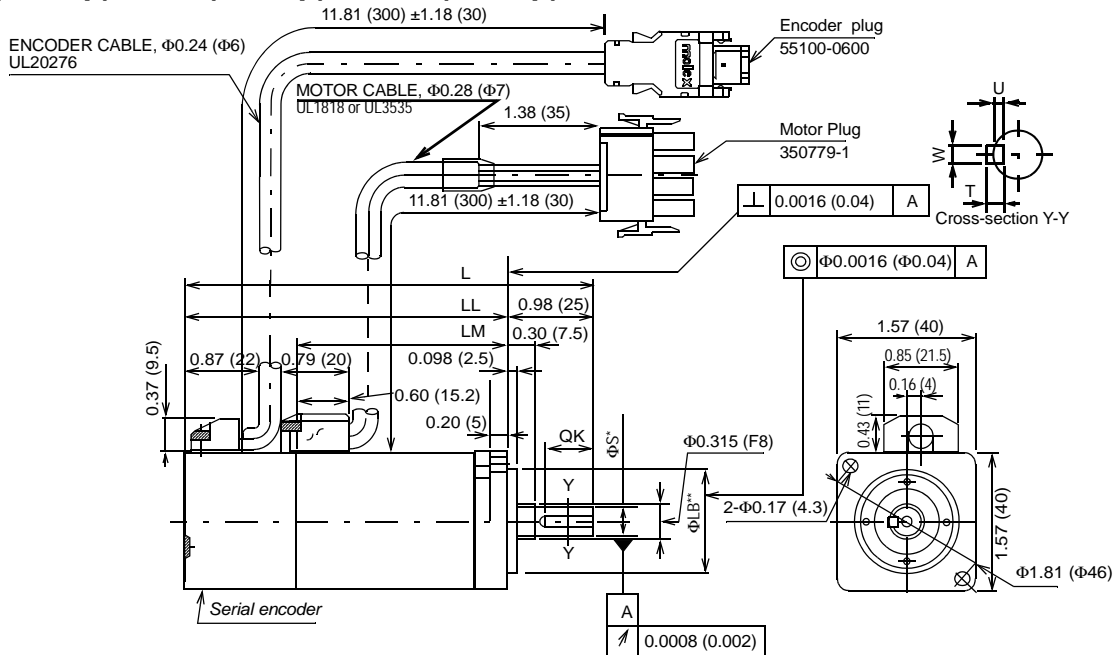

Type SGMAH-†	QK	U	W	T	L	LL	LM	ΦS*	ΦLB**	Output W (hp)	Approximate Mass lb (kg)	Allowable Radial Load lb (N)	Allowable Thrust Load lb (N)
A3□□F2□	Without Keyway				3.72 (94.5)	2.74 (69.5)	1.44 (36.5)	0.24 (6)	1.18 (30)	30 (0.04)	0.66 (0.3)	15 (68)	12 (54)
A3□□F4□	0.55 (14)	0.047 (1.2)	0.079 (2)	0.079 (2)									
A5□□F2□	Without Keyway				4.02 (102)	3.03 (77)	1.73 (44)			50 (0.07)	0.88 (0.4)		
A5□□F4□	0.55 (14)	0.047 (1.2)	0.079 (2)	0.079 (2)						100 (0.13)	1.10 (0.5)	17 (78)	
01□□F2□	Without Keyway				4.7 (119.5)	3.72 (94.5)	2.42 (61.5)	0.31 (8)					
01□□F4□	0.55 (14)	0.07 (1.8)	0.12 (3)	0.12 (3)									

†Some motor dimensions vary for motors with the optional shaft seal: See p.19 for details.

Connector Specifications

Specified Tolerances				
Dimension	*ΦS		**ΦLB	
Unit	Diameter	Tolerance	Diameter	Tolerance
in	0.2362	+0.0000-0.0003	1.181	+0.0000 -0.0008
	0.3150	+0.0000-0.0004		
mm	6.000	+0.000 -0.008	30.000	+0.000 -0.021
	8.000	+0.000 -0.009		

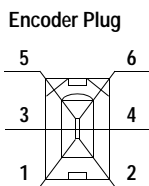

Encoder Connection		
Pin	Output	Wire Color
1	PG 5V	Red
2	PG 0V	Black
3	Battery +	Orange
4	Battery -	White/Orange
5	Data +	Light Blue
6	Data -	White/Light Blue

Note: Pins Number 3 and 4 are connectors used for 16-bit absolute encoder option only.

Plug: 55100-0600 (Molex)

Mating connector:

Socket: 54280-0600

Motor Plug

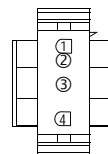

Motor Connection		
Pin	Output	Wire Color
1	Phase U	Red
2	Phase V	White
3	Phase W	Blue
4	FG (Frame Ground)	Green/Yellow

Plug: 350779-1 (AMP)

Pin: 350561-3 or 350690-3 (Nos. 1 to 3)

Ground pin: 770210-1 (No 4)

Mating connector:

Cap: 350780-1

Socket: 350570-3 or 350689-3

100/200V Single-phase Sigma II Servo Systems

- 200W (0.27hp), 400W (0.53hp), 750W (1.01hp)

SGMAH Servomotors

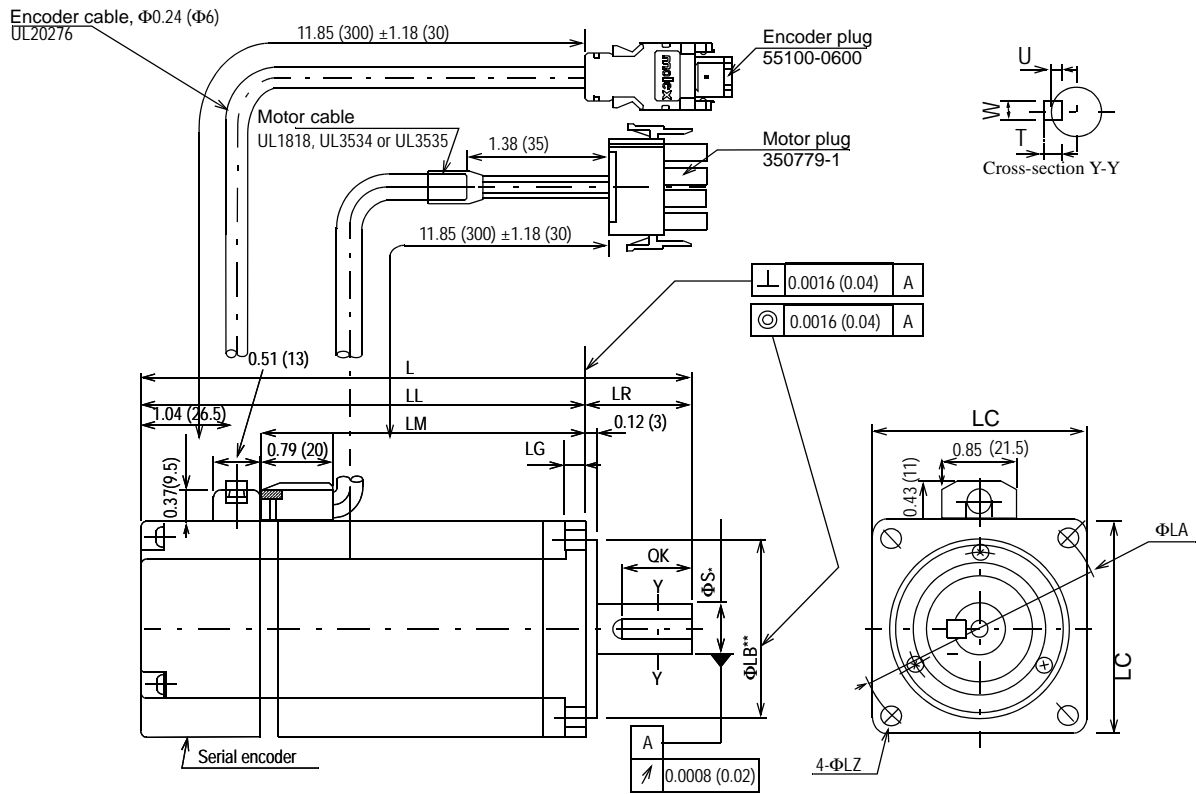

Type SGMAH-†	L	LL	LM	LR	LG	LC	ΦLA	ΦLZ	ΦS^*	ΦLB^{**}	QK	U	W	T	Output W (hp)	Approximate Mass lb (kg)	Allowable Radial Load lb (N)	Allowable Thrust Load lb (N)
02□□F4□	4.98 (126.5)	3.8 (96.5)	2.46 (62.5)	1.18 (30)	0.24 (6)	2.36 (60)	2.76 (70)	0.22 (5.5)	0.55 (14)	1.97 (50)	0.79 (20)	0.12 (3)	0.2 (5)	0.2 (5)	200 (0.27)	2.43 (1.1)	55 (245)	17 (74)
04A□F4□	6.08 (154.5)	4.9 (124.5)	3.56 (90.5)												400 (0.53)			
08A□F4□	7.28 (185)	5.71 (145)	4.37 (111)	1.57 (40)	0.31 (8)	3.15 (80)	3.54 (90)	0.28 (7)	0.63 (16)	2.76 (70)	1.18 (30)	0.12 (3)	0.2 (5)	0.2 (5)	750 (1.01)	7.5 (3.4)	88 (392)	33 (147)

*Please see the following table for dimension tolerances.

†Some motor dimensions vary for motors with the optional shaft seal: See p.20 for details.

Specified Tolerances				
Dimension	* ΦS		** ΦLB	
Unit	Diameter	Tolerance	Diameter	Tolerance
in	0.5512	+0.0000-0.0004	1.9685	+0.0000 -0.0010
	0.6299	+0.0000-0.0004	2.7559	+0.0000 -0.0012
mm	14.000	+0.000 -0.011	50.000	+0.000 -0.025
	16.000	+0.000 -0.011	70.000	+0.000 -0.030

(2) 13-Bit Incremental or 16-Bit Absolute Encoder, with Brake

- 30W (0.04hp), 50W (0.07hp), 100W (0.13hp)

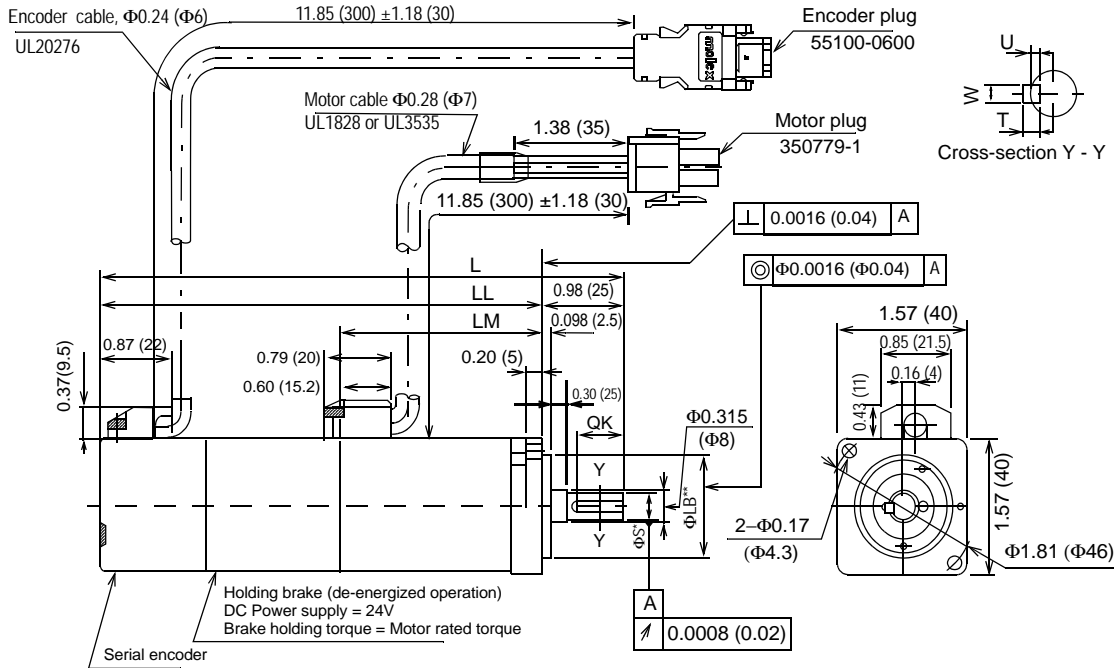

Type SGMAH [†]	U	W	T	L	LL	LM	ΦS*	ΦLB**	QK	Output W (hp)	Approximate Mass lb (kg)	Allowable Radial Load lb (N)	Allowable Thrust Load lb (N)
A3□□F2C	0.047 (1.2)	0.079 (2)		4.96 (126)	3.98 (101)	1.44 (36.5)	0.24 (6)	1.18 (30)	0.55 (14)	30 (0.04)	1.32 (0.6)	15 (68)	12 (54)
A3□□F4C				5.26 (133.5)	4.27 (108.5)	1.73 (44.0)				50 (0.07)	1.54 (0.7)		
A5□□F2C				6.3 (160)	5.31 (135)	2.42 (61.5)				100 (0.13)	1.76 (0.8)		
A5□□F4C				6.3 (160)	5.31 (135)	2.42 (61.5)				100 (0.13)	1.76 (0.8)		

[†]Some motor dimensions vary for motors with the optional shaft seal: See p.19 for details.

Specified Tolerances				
Dimension	*ΦS		**ΦLB	
Unit	Diameter	Tolerance	Diameter	Tolerance
in	0.2362	+0.0000-0.0003	1.181	+0.0000-0.0008
	0.3150	+0.0000-0.0004		
mm	6.000	+0.000-0.008	30.000	+0.000-0.021
	8.000	+0.000-0.009		

Connector Specifications:

Motor Plug

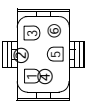

Motor Connection		
1	Phase U	Red
2	Phase V	White
3	Phase W	Blue
4	FG (Frame Ground)	Green/Yellow
5	Brake Terminal	Red
6	Brake Terminal	Black

Plug: 350715-1 (AMP)
 Pin: 350561-3 or 350690-3 (except No. 4)
 Ground pin: : 770210-1 (No. 4)
 Mating connector:
 Cap: 350781-1
 Socket: 350570-3 or 350689-3

Encoder Plug

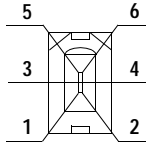

Encoder Connection		
1	PG 5V	Red
2	PG 0V	Black
3	Battery +	Orange
4	Battery -	White/Orange
5	Data +	Light Blue
6	Data -	White/Light Blue

Note: Pins number 3 and 4 are connectors used for 16-bit absolute encoder option only.

Plug: 55100-0600 (Molex)
 Mating connector:
 Socket: 54280-0600

100/200V Single-phase Sigma II Servo Systems

- 200W (0.27hp), 400W (0.53hp), 750W (1.01hp)

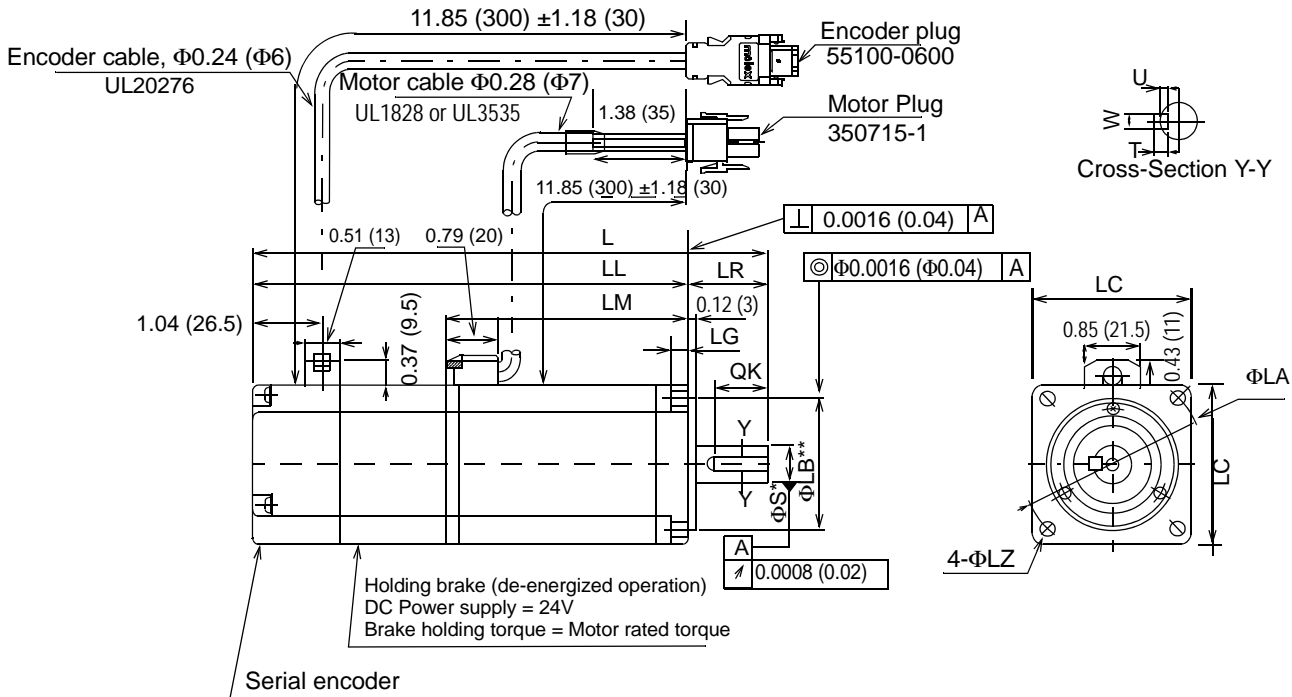

SGMAH Servomotors

Type SGMAH [†]	U	W	T	L	LL	LM	LR	LG	LC	ΦLA	ΦLZ	ΦS*	ΦLB**	QK	Output W (hp)	Approximate Mass lb (kg)	Allowable Radial Load lb (N)	Allowable Thrust Load lb (N)
02□□F4C	0.12 (3)	0.2 (5)		6.54 (166)	5.35 (136)	2.46 (62.5)	1.18 (30)	0.24 (6)	2.36 (60)	2.76 (70)	0.22 (5.5)	0.55 (14)	1.97 (50)	0.79 (20)	200 (0.27)	3.53 (1.6)	55 (245)	17 (74)
04A□F4C				7.64 (194)	6.46 (164)	3.56 (90.5)									400 (0.53)	4.85 (2.2)		
08A□F4C				9.04 (229.5)	7.46 (189.5)	4.37 (111)	1.57 (40)	0.31 (8)	3.15 (80)	3.54 (90)	0.28 (7)	0.64 (16)	2.76 (70)	1.18 (30)	750 (1.01)	9.48 (4.3)	88 (392)	33 (147)

[†]Some motor dimensions vary for motors with the optional shaft seal: See p.20 for details.

Specified Tolerances				
Dimension	*ΦS		**ΦLB	
Unit	Diameter	Tolerance	Diameter	Tolerance
in	0.5512	+0.0000-0.0004	1.9685	+0 -0.0010
	0.6299	+0.0000-0.0004	2.7558	+0 -0.0012
mm	14.000	+0.000 -0.011	50.000	+0 -0.025
	16.000	+0.000 -0.011	70.00	+0 -0.03

100/200V Single-phase Sigma II Servo Systems

SGMAH Servomotors

- 200W (0.27hp), 400W (0.54hp) with NEMA 23* Flange/Pilot

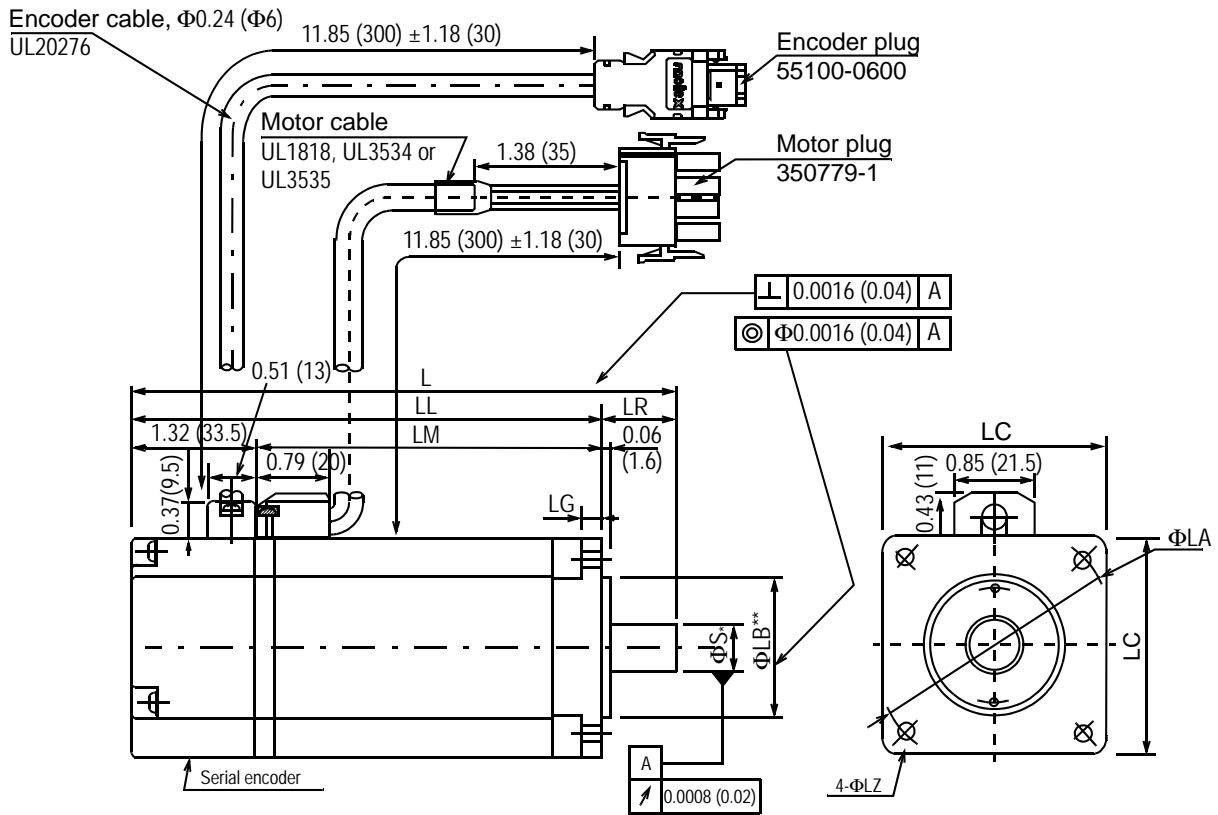

Type SGMAH-	L	LL	LM	LR	LG	LC	ΦLA	ΦLZ	ΦS*	ΦLB**	Output W (hp)	Approximate Mass lb (kg)	Allowable Radial Load lb (N)	Allowable Thrust Load lb (N)
02□AN21	4.67 (118.5)	3.9 (98.5)	2.56 (65)	0.79 (20)	0.24 (6)	2.36 (60)	2.63 (66.7)	0.18 (4.5)	0.50 (12.7)	1.5 (38.1)	200 (0.27)	2.43 (1.1)	55 (245)	17 (74)
04□AN21	5.77 (146.5)	5.0 (126.5)	3.66 (93)								400 (0.53)			

Specified Tolerances				
Dimension	*ΦS		**ΦLB	
Unit	Diameter	Tolerance	Diameter	Tolerance
in	0.5000	+0 -0.00043	1.5000	+0.0000 -0.00098
mm	12.7	+0 -0.011	38.1	+0.000 -0.025

*For servo application torques: shaft diameter is 0.5in (12.7mm) rather than 0.25 (6.35mm), as is in typical NEMA 23.

100/200V Single-phase Sigma II Servo Systems

SGMAH
Servomotors

- 750W (1.01hp) with NEMA 34* Flange/Pilot

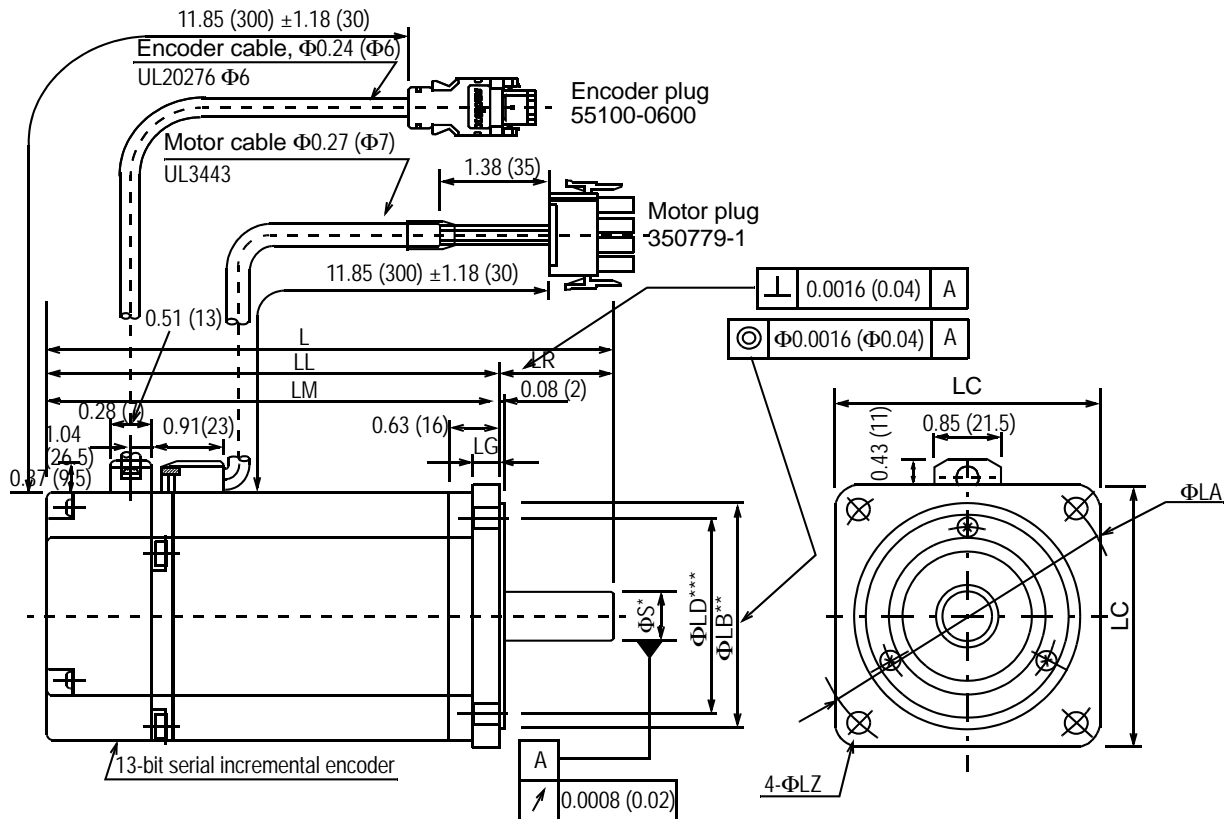

Type SGMAH-	L	LL	LM	LR	LG	LC	ΦLA	ΦLZ	ΦS*	ΦLB**	ΦLD***	Output W (hp)	Approx Mass lb (kg)	Allowable Radial Load lb (N)	Allowable Thrust Load lb (N)
08A□N21	7.20 (183)	5.75 (146)	4.43 (112.5)	1.46 (37)	0.31 (8)	3.35 (85)	3.87 (98.4)	0.28 (7)	0.63 (16)	2.87 (73)	2.60 (66)	750 (1.01)	7.5 (3.4)	88 (392)	33 (147)

Specified Tolerances						
Dimension	*ΦS		**ΦLB		**ΦLD	
Unit	Diameter	Tolerance	Diameter	Tolerance	Diameter	Tolerance
in	0.625	+0.0000-0.00043	2.874	+0.0000 -0.0012	2.598	+0.00012 -0
mm	15.875	+0.000 -0.011	73.000	+0.000 -0.030	66.000	+0.003 -0

*For servo application torques: shaft diameter is 0.625in (15.875mm) rather than 0.375 (9.525mm), as is in typical NEMA 34.

100/200V Single-phase Sigma II Servo Systems

SGMAH
Servomotors

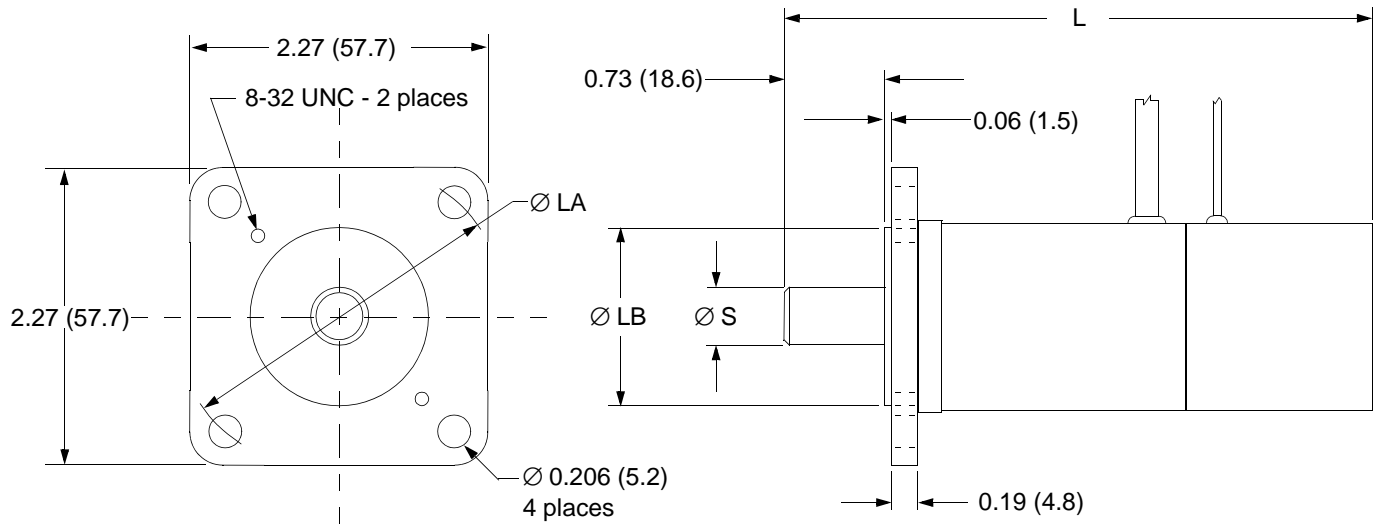

Motor type	*Dimensions - Inch (mm)			
	L	Ø S	Ø LB	Ø LA
SGMAH-A3 w/NEMA 23 Adaptor	3.72 (94.5)	0.2362 +.000 / -.0003 (6.0 +.000 / -.006)	1.500 +.002 / -.002 (38.1 +.05 / -.05)	2.625 (66.7)
SGMAH-A5 w/NEMA 23 Adaptor	4.02 (102)	0.2362 +.000 / -.0003 (6.0 +.000 / -.006)	1.500 +.002 / -.002 (38.1 +.05 / -.05)	2.625 (66.7)
SGMAH-01 w/NEMA 23 Adaptor	4.70 (119.5)	0.3150 +.000 / -.0004 (8.0 +.000 / -.009)	1.500 +.002 / -.002 (38.1 +.05 / -.05)	2.625 (66.7)

*Dimensions include a field installed SGM-N23 adaptor flange on the listed motor.

Dimension Modifications for Motors with Optional Shaft Seal

- 30W (0.04hp), 50W (0.07hp), 100W (0.13hp)

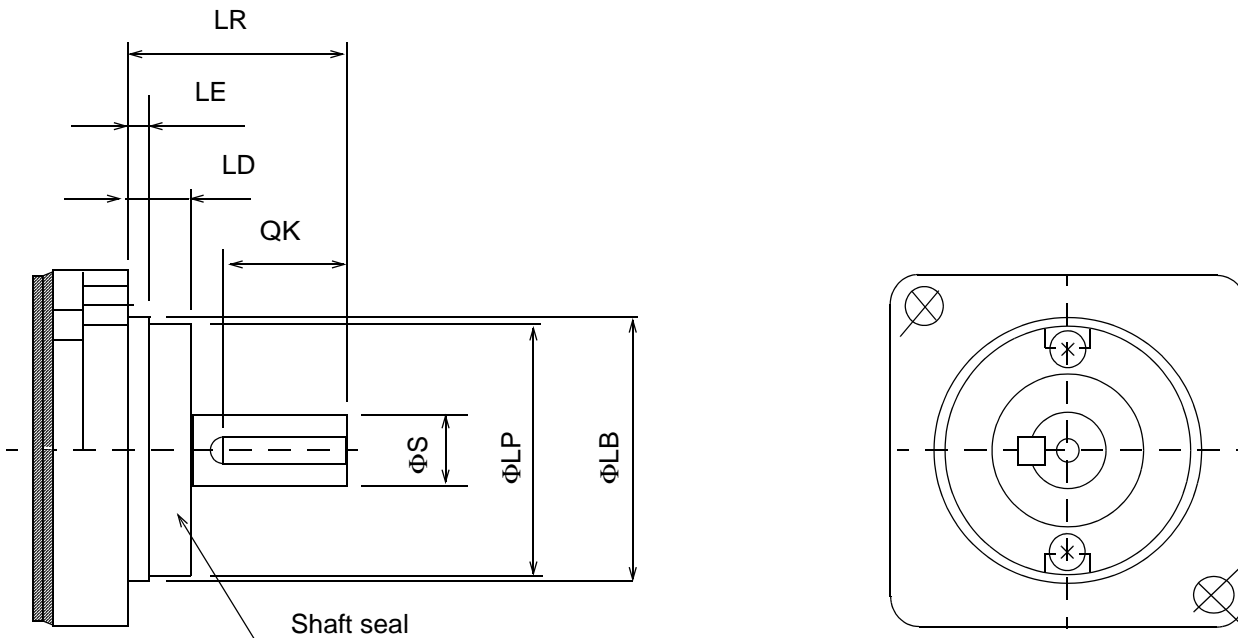

Type SGMAH-	QK	ϕLB^*	ϕS^*	LE	LR	LD	ϕLP
A3	0.55 (14)	1.18 (30)	0.236 (6)	0.10 (2.5)	0.98 (25)	0.30 (7.5)	1.14 (28)
A5			0.315 (8)				
01							

*Tolerances for diameters LB and S are the same as those for motors without shaft seals.

100/200V Single-phase Sigma II Servo Systems

- 200W (0.27hp), 400W (0.53hp), 750W (1.01hp)

SGMAH Servomotors

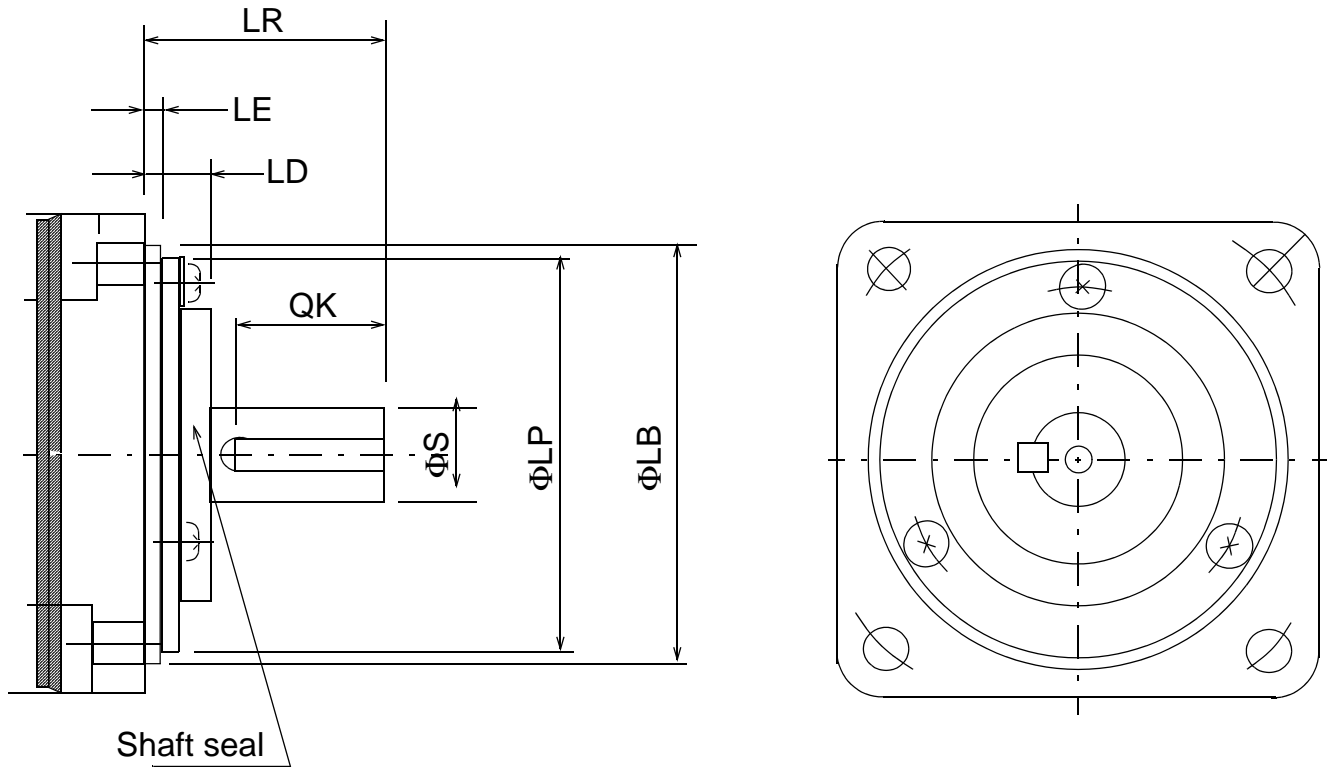

Type SGMAH-	QK	φLB*	φS*	LE	LR	LD	φLP
02	0.55 (14)	1.97 (50)	0.55 (14)	0.12 (3)	1.18 (30)	0.39 (10)	1.89 (48)
04							
08	0.98 (25)	2.76 (70)	0.63 (16)		1.57 (40)	0.43 (11)	2.60 (66)

*Tolerances for diameters LB and S are the same as those for motors without shaft seals.

Torque Reduction Factor for SGMAH motors equipped with a shaft seal:

Servo Motor Model	A3	A5	01	02	04	08
Torque Reduction Factor	70%	80%	90%	90%	95%	95%

For example: The SGMAH-A3 continuous and peak torque rating should be reduced to 70% of the listed catalog specification.

To specify a motor with a shaft seal, refer to the motor part number explanation on the following page.

Selecting Your SGMAH Sigma II Servo System

First, select the Sigma II servomotor suited for your application using SigmaSize: the Yaskawa servomotor sizing software, available at no charge. (Request SigmaSize software via e-mail, at: literature@yaskawa.com).

Use the diagram below to locate and identify the components of your system. Each item is letter-coded and cross-referenced in the option tables on the following pages.

System Configuration

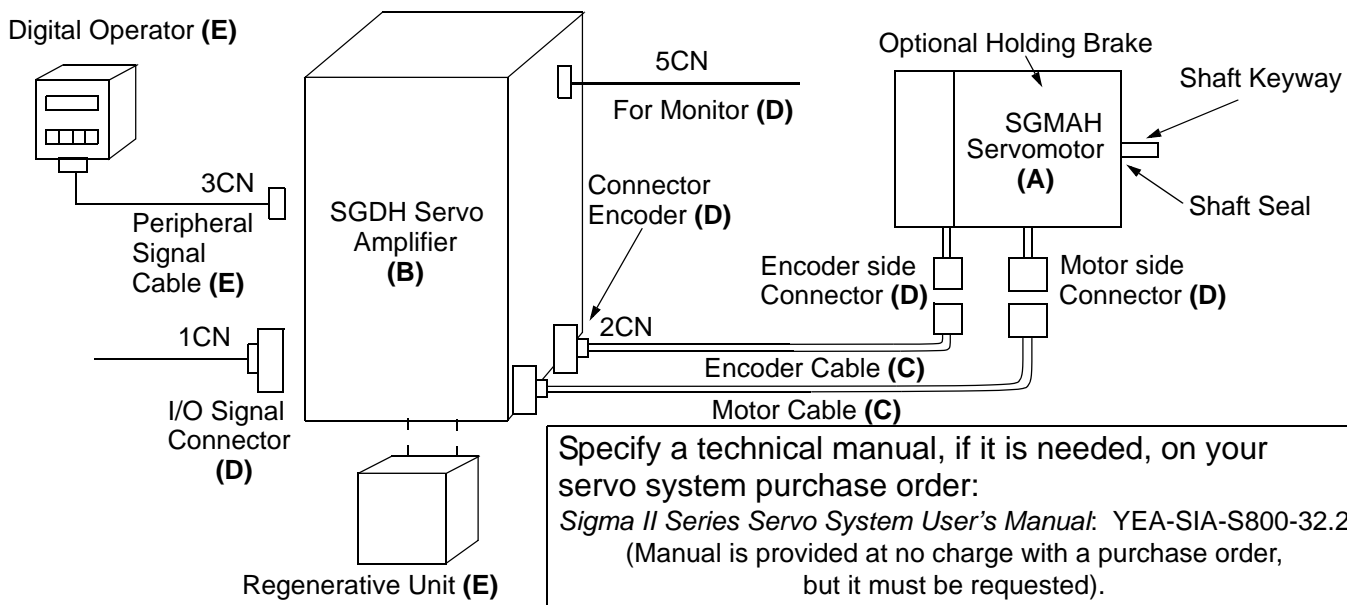

Model Number Designation

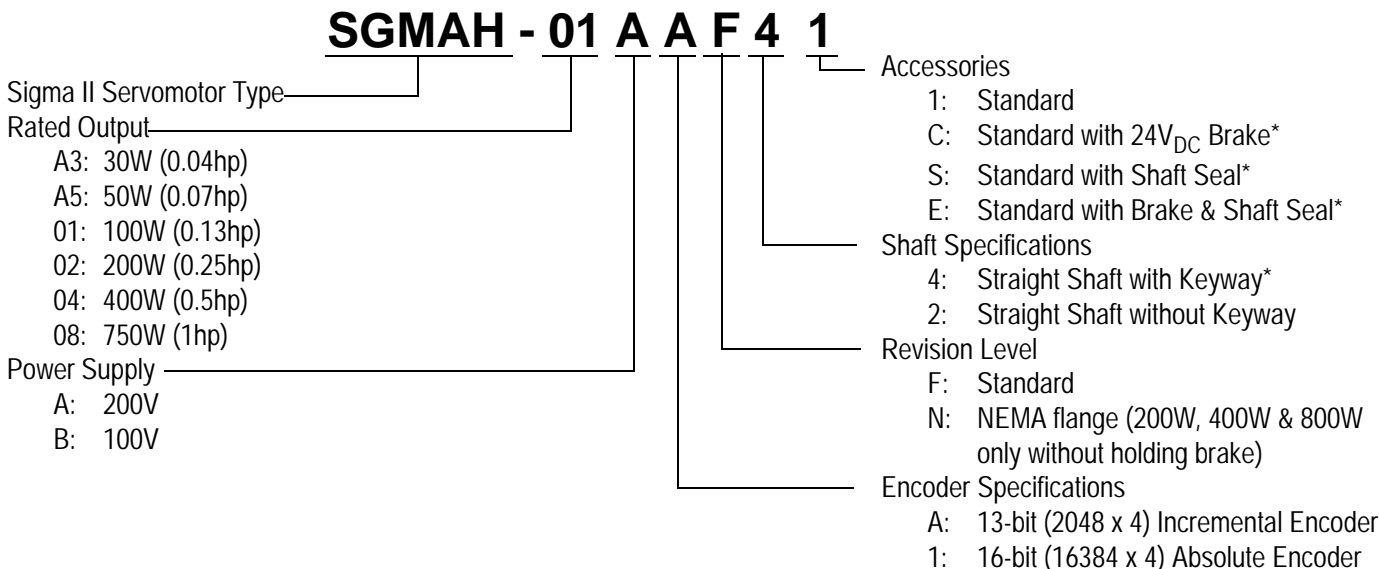

* Keyways, shaft seals, and holding brakes not available on motors with NEMA flanges (revision level = N).

Servomotor & Amplifier Selection

Use the table below to select the recommended SGMAH Sigma II servomotor and amplifier.
(Refer to the motor model # designation on the previous page specifying the available modification to motor construction/features.)

Motors Used with 13-bit Incremental Encoders (5000rpm Maximum)					Amplifier		
Description	Peak Torque (oz · in)	Rated Torque (oz · in)	Motor Inertia (oz · in · s ² × 10 ⁻³)	Motor MODEL NUMBER (A)	Amplifier MODEL NUMBER (B)*		Motor & Amplifier Item Class
					Single-Phase SGD H	3-Phase SGD H-	
200V, Single-Phase Straight Shaft without Keyway	40.5	13.5	0.235	SGMAH-A3AAF21	A3AE	-	Stock
			0.355	SGMAH-A3AAF2C			
	67.7	22.6	0.312	SGMAH-A5AAF21	A5AE	-	
			0.432	SGMAH-A5AAF2C			
	135	45.1	0.515	SGMAH-01AAF21	01AE	-	
			0.635	SGMAH-01AAF2C			
0.515			SGMAH-01AAF41	01AE			
0.635			SGMAH-01AAF4C				
200V, Single-Phase, Straight Shaft with Keyway	270	90.1	1.50	SGMAH-02AAF41	02AE	-	
			2.321	SGMAH-02AAF4C			
	542	181	2.45	SGMAH-04AAF41	04AE	-	
			3.271	SGMAH-04AAF4C			
1010	338	9.52	SGMAH-08AAF41	08AE-S	08AE		
		11.5	SGMAH-08AAF4C				
200V, Single-Phase, Straight Shaft without Keyway NEMA flange	135	45.1	0.515	SGMAH-01AAF21**	01AE	-	
			0.635	SGMAH-01AAF2C**			
	270	90.1	1.50	SGMAH-02AAN21***	02AE	-	
	542	181	2.45	SGMAH-04AAN21***			
1010	338	9.52	SGMAH-08AAN21****	08AE-S	08AE		
100V, Single-Phase, Straight Shaft without Keyway	40.5	13.5	0.235	SGMAH-A3BAF21	A3BE	-	
			0.355	SGMAH-A3BAF2C			
	67.7	22.6	0.312	SGMAH-A5BAF21	A5BE	-	
			0.432	SGMAH-A5BAF2C			
	135	45.1	0.515	SGMAH-01BAF21	01BE	-	
			0.635	SGMAH-01BAF2C			
0.515			SGMAH-01BAF41	01BE			
0.635			SGMAH-01BAF4C				
200V, Single-Phase, Straight Shaft with Keyway	270	90.1	1.50	SGMAH-02BAF41	02BE	-	
			2.321	SGMAH-02BAF4C			
	542	181	2.45	SGMAH-04AAF41	04FE	-	
			3.271	SGMAH-04AAF4C			
100V, Single-Phase, Straight Shaft without Keyway NEMA flange	135	45.1	0.515	SGMAH-01BAF21**	01BE	-	
			0.635	SGMAH-01BAF2C**			
	270	90.1	1.50	SGMAH-02BAN21***	02BE	-	
542	181	2.45	SGMAH-04AAN21***	04FE	-		

Notes: 24V_{DC} brakes for SGMAH Sigma II servomotors are standard. Contact a local source for 24V_{DC} power supplies.

Motor power and encoder cables are factory pre-wired with approximately 13" lead length with amplifier mating connectors.

Use the tables on the following pages to specify mating connectors or pre-wired cables available in various lengths.

For technical information, request Yaskawa manual number YEA-SIA-S800-32.2.

* For more detailed SGD H amplifier specifications and dimensions, refer to pages 95 to 110.





** NEMA 23 adapter flange (see "Peripheral Device Selection")

*** NEMA 23 flange and pilot (see "Dimensions in inches (mm)")

**** NEMA 34 flange and pilot (see "Dimensions in inches (mm)")

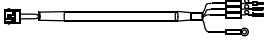
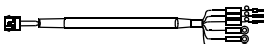
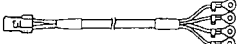
Pre-wired Cable Selection

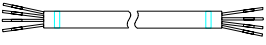

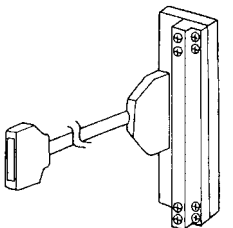
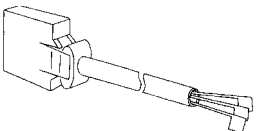
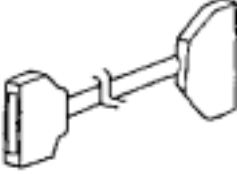
Use the table below to select pre-wired cables for your SGMAH Sigma II servomotor.

Cable Description (C)		Motor Size (kW)	Part Number*	Comments	Item Class
Power Cable without Brake		All	JZSP-CMM00-□□(A)	These cables are available in five lengths. Use two digits in the part number's last place: 03: 3m 05: 5m 10: 10m (standard) 15: 15m 20: 20m	Stock**
Power Cable with Brake			JZSP-CMM10-□□(A)		
Shielded Power Cable without Brake***			BAHCE-□□(A)		
Shielded Power Cable with Brake***			BAHBCE-□□(A)		
Encoder Cable (incremental and absolute)	—		JZSP-CMP00-□□(A)		—
Encoder Cable (for applications up to 20m) Only for Solder Connections			FR-RMCT-SB	These cables are available in any length. For example, to order one FR-RMCT-SB cable, 16m long, specify: quantity: 16 part no.: FR-RMCT-SB	Stock
Encoder Cable (for applications from >20 to <50m maximum) Only for Solder Connections			UL20276-SB		
Input/Output 1CN Cable & Transition Terminal Block			JUSP-TA50P	35mm DIN rail mountable; the cable length is 0.5 meters.	
Input/Output 1CN Cable with Pigtail Leads			JZSP-CKI01-□(A)	Use the following key to specify required cable length (last digit of part number): 1: 1m (standard) 2: 2m 3: 3m	
Input/Output 1CN Cable Cable with Female D-Sub output Connector****			JZSP-CKI0D-□□	Use the following key to specify required cable length (last two digits of the part number): D50: 0.5m 01: 1m (standard) 02: 2m 03: 3m	

* "(A)" at the end of the cable part number is the revision level. Revision level may be changed prior to this catalog reprinting.
 ** Standard cable lengths are Stock items; non-standard cable lengths are Limited Stock items.
 *** Use these power cables where it is important to meet CE (EMC) requirements.
 **** 50 Pin Female D-Sub output connector mates to customer supplied third party terminal block. (e.g., Wago #289-449, Weidmuller #919658, Phoenix #2283647, Amphenol/Sine #20-51039, and many others).

Connector Selection

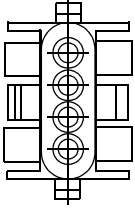
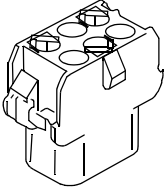
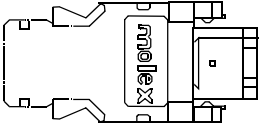
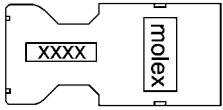
Use the table below to select mating connectors or kits for your SGMAH Sigma II servomotor.

Connector Description (D)		Motor Size (kW)	Part Number	Comments	Item Class
Motor Power Mating Connector (without Brake)		All	JZSP-CMM9-1	These connector kits include pin and socket. Requires use of Amp Crimp Tool (90548-1). (See below).	Stock
Motor Power Mating Connector (with Brake)			JZSP-CMM9-2		
Amp Crimp Tool	—		90548-1	Crimp tool for Motor Power Connector (JZSP-CMM9-□)	Limited Stock
2CN Amplifier Mating Connector			JZSP-CMP9-1	—	Stock
Motor Encoder Mating Connector			JZSP-CMP9-2	—	
1CN Mating Connector			JZSP-CKI9	for SGDh I/O 50-pin	
3CN Peripheral Mating Connector	—		YSC-1	—	
5CN Analog Monitor Connector	—		DE9404559	—	

Peripheral Device Selection

Use the table below to select peripheral devices for your SGMAH Sigma II servomotor.

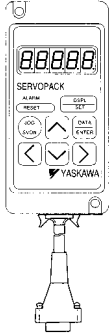
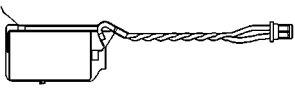
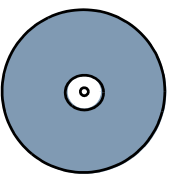
Component	Description (E)	Part Number	Comments	Item Class
Hand-held Digital Operator Panel		JUSP-OP02A-1 and JZSP-CMS00-1	Portable unit with 1m adapter cable for Sigma II	Stock
Absolute Encoder Battery		JZSP-BA01	3.6V, 1000mAh (lithium battery)	
Software Interface Cable	—	YS-12	Pre-wired 2.0m cable with 9-pin connector	
SigmaWin+ Software		JZSP-WP0001	Minimum Recommended System Requirements Pentium 200 MHz, 64MB RAM, 200MB hard drive, CDROM Drive, RS-232 or RS-422 port, Screen resolution 800x600 w/ 256 colors, and Windows 95,98,NT4.0,2000,ME. (Windows XP planned)	
DC Reactor (for suppressing harmonics in the power supply)	For 200V: SGDH-A3AE SGDH-A5AE SGDH-01AE SGDH-02AE SGDH-04AE SGDH-08AE SGDH-08AE-S	— — X5071 X5070 X5069 X5061 X5079	—	Limited Stock
	For 100V: SGDH-A3BE SGDH-A5BE SGDH-01BE SGDH-02BE	— — X5063 X5062	—	
Individual External Regenerative Unit	50 Ω, 70W for A3, A5, 01, 02, 04, AND 08 AMPS	RH120-50ohmJ	This is a general purpose regenerative unit.* Caution: Proper set-up is necessary to avoid equipment damage.	Stock
NEMA Flange Adapter	—	SGM-N23	For 30, 50, and 100W SGMAH motors only. Complies to NEMA 23 mounting standard.	

* Refer to the SGDh servo amplifier section of this catalog for additional specifications, and the *Sigma II Series Servo System User's Manual* (YEA-SIA-S800-32.2) for proper resistor sizing guidelines.

NOTES:



Flat Series SGMPH Servomotors - With Incremental / Absolute Encoder

Rated Output: 100W, 200W, 400W,
750W, 1500W



For Additional Information	Page(s)
SGMPH Ratings & Specifications	30
SGMPH Speed/Torque Curves	31
SGMPH Dimensions	32 - 40
SGMPH Selection/Ordering Information	41 - 45
SGDH Ratings & Specifications	99 - 100
SGDH Dimensions	101 - 112

Design Features

1. Compact

- The length is about 1/2 of conventional motors
- Enhanced withstand load since motor output shaft bearing size is upgraded
- Up to 5000rpm maximum speed

2. Enhanced Environmental Resistance

- Water resistance (not including the shaft), IP67 standard
- Optional shaft seals available
- Reinforced lead-out cable access

3. Encoders (reduced wiring serial encoder)

- 13-bit (2,048ppr x 4) incremental encoder (standard)
- 16-bit (16,384ppr x 4) absolute encoder (option)

4. Application Emphasis

- Chip mounters
- PCB drilling machines
- Robots
- Conveyor
- Packaging

5. Certified International Standards

- UL, cUL recognized, (File #: E165827), CE compliance

Servomotor Ratings and Specifications

Time Rating:	Continuous	Enclosure: Totally-enclosed, self-cooled	Excitation:	Permanent magnet
Insulation:	Class B	Ambient Temperature: 0 to 40°C	Drive Method:	Direct drive
Vibration:	15µm or less	Ambient Humidity: 20 to 80%	Mounting:	Flange-mounted
Withstand Voltage:	1500V _{ac}	(non-condensing)	Applicable Encoder:	13-bit Incremental and 16-bit Absolute encoder
Insulation Resistance:	500V _{DC} 10MΩ or more	Rated Rotation Speed: 3000rpm Maximum Rotation Speed:5000rpm		

SGMPH Servomotors

Applied Voltage	MOTORS: SGMPH-	Rated Output	Rated Torque		Instantaneous Peak Torque		Continuous Rated Current*	Maximum Peak Current*	Rated Angular Acceleration	Rated Power Rate
		W (hp)	oz · in	N · m	oz · in	N · m	A _{rms}	A _{rms}	rad/s ²	kW/s
200V _{ac}	01A	100 (0.13)	45.1	0.318	135	0.96	0.89	2.8	64800	20.4
	02A	200 (0.27)	90.1	0.637	270	1.91	2.0	6.0	33000	21.0
	04A	400 (0.54)	180	1.27	542	3.82	2.6	8.0	38500	49.0
	08A	750 (1.01)	338	2.39	1010	7.1	4.1	13.9	11400	27.0
	15A	1500 (2.01)	676	4.77	2027	14.3	7.5	23.0	11900	56.7
100V _{ac}	01B	100 (0.13)	45.1	0.318	135	0.96	2.2	7.1	64800	20.4
	02B	200 (0.27)	90.1	0.637	270	1.91	2.7	8.4	33000	21.0
	04A**	400 (0.54)	180	1.27	542	3.82	2.6	8.0	38500	49.0

* Values are calculated when the servomotor is combined with an SGDH servo amplifier.

** When combined with an SGDH-04FE

System Voltage	MOTORS SGMPH-	Moment of Inertia				Holding Brake (at 20°C)			Allowable Load Inertia *
		Motor without Brake		Motor with Brake		Capacity	Coil Resistance	Rated Current	
		oz · in · s ² × 10 ⁻³	KG · m ² × 10 ⁻⁴	oz · in · s ² × 10 ⁻³	KG · m ² × 10 ⁻⁴				
200V _{ac}	01A	0.695	0.0491	1.106	0.0781	6	96	0.25	1.20
	02A	2.73	0.193	4.274	0.302	5	115	0.21	3.69
	04A	4.69	0.331	6.234	0.44	7.6	76	0.32	3.82
	08A	29.7	2.10	42.09	2.975	7.5	77	0.31	13.4
	15A	56.9	4.02	69.29	4.895	10	58	0.42	24.1
100V _{ac}	01B	0.695	0.0491	1.106	0.0781	6	96	0.25	1.20
	02B	2.73	0.193	4.274	0.302	5	115	0.21	3.69
	04A	4.69	0.331	6.234	0.44	7.6	76	0.32	3.82

* Allowable load inertia (J_L) shows the range requiring no exterior regenerative unit. When these values are exceeded, application may be restricted or a regenerative unit may be required. Values are calculated when the servomotor is combined with an SGDH servo amplifier.

MOTORS SGMPH-	Servomotor Capacity W	Holding Brake	
		Holding Torque	
		oz-in	KG · cm
01□	100	69.5	5.0
02□	200	139	10
04A	400	279	20
08A	750	514	37
15A	1500	1015	73

Speed / Torque Curves

200V

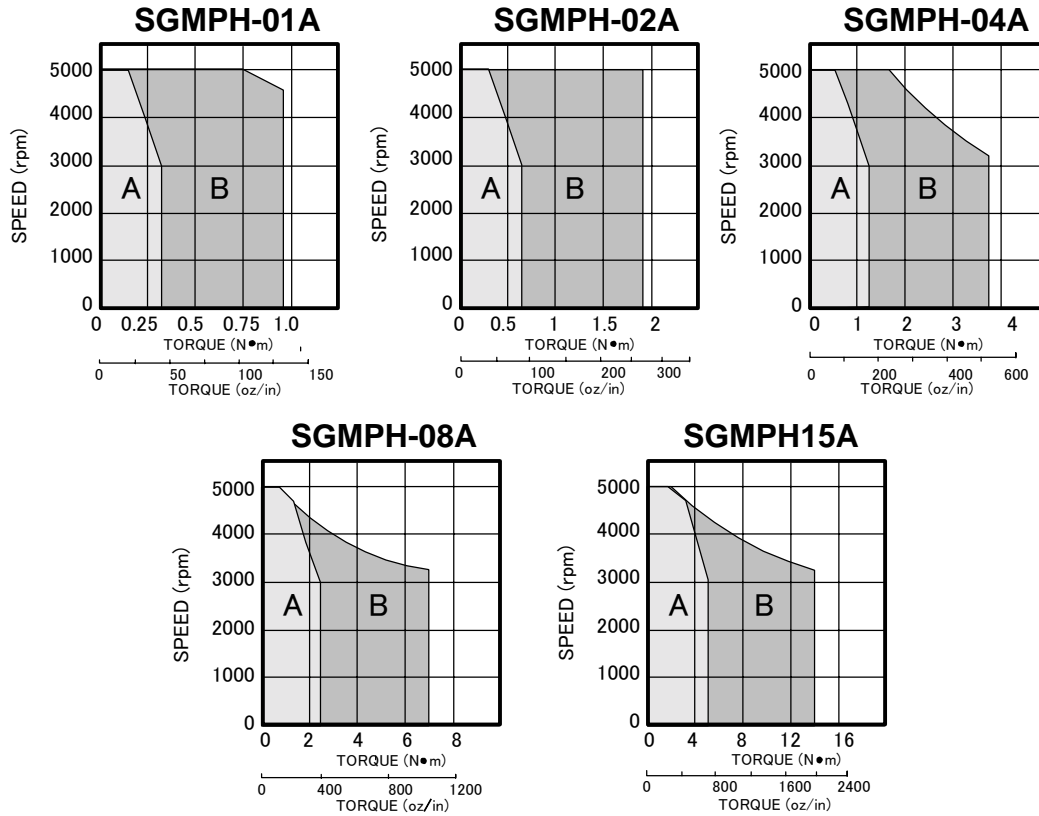

100V

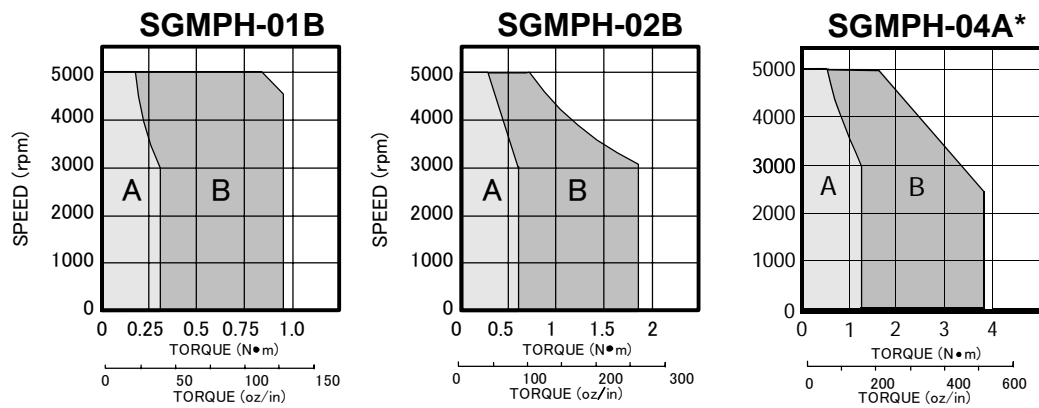

A : CONTINUOUS DUTY ZONE

B : INTERMITTENT DUTY ZONE

*When combined with SGD4FE amplifier.

Dimensions in inches (mm)

(1) 13-Bit Incremental or 16-Bit Absolute Encoder, w/o Brake

- Note:
1. The keyway complies with JIS B1301-1976 (precision). A straight key is supplied.
 2. Conforms to the IP67 enclosure, excluding the shaft (optional shaft seal available).
 3. The quoted allowable radial load is the value at a position 5mm (0.2in) from the shaft end.

• 100W (0.13hp)

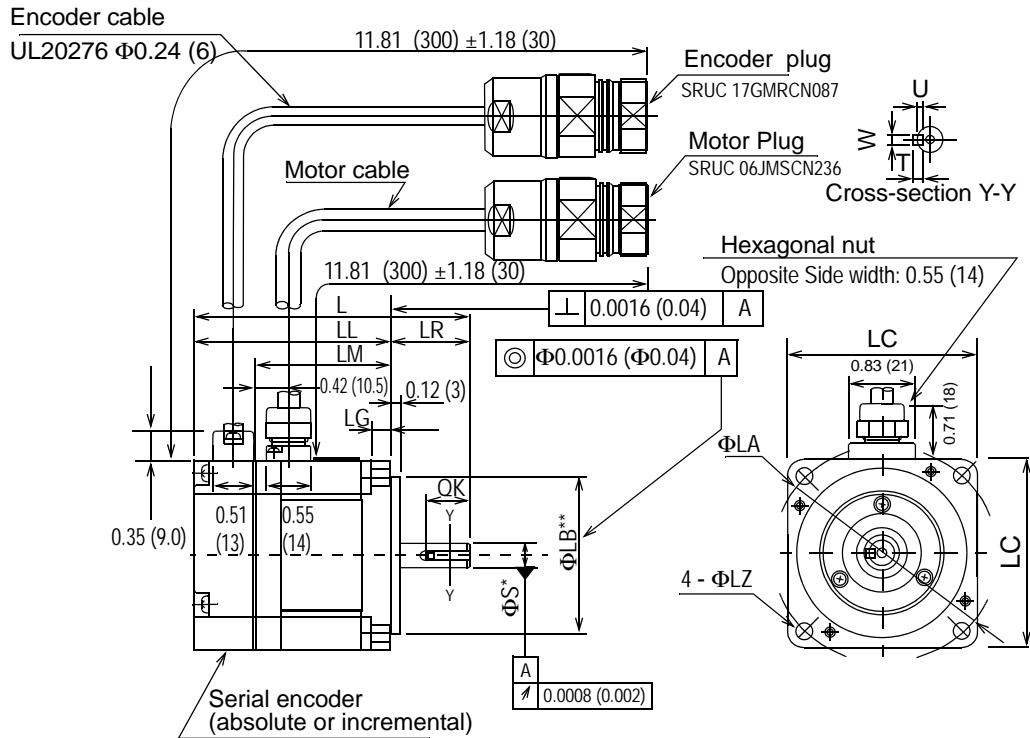

Type SGMPH-	L	LL	LM	LR	LG	LC	ΦLA	ΦLZ	ΦS*	ΦLB**	Key				Output W (hp)	Torque in-lb (N·m)	Time Rating	Rated Speed (rpm)	Approx Mass lb (kg)	Allowable Radial Load lb (N)	Allowable Thrust Load lb (N)
											OK	U	W	T							
01□□E41D	3.43	2.44	1.67	0.98	0.24	2.36	2.76	0.21	0.315	1.97	0.55	0.071	0.12	0.12	100	2.81	Continuous	3000	1.54	17.5	11.0
01□□E41D	(87)	(62)	(42.5)	(25)	(6)	(60)	(70)	(5.3)	(8)	(50)	(14)	(1.8)	(3)	(3)	(0.13)	(0.318)			(0.7)	(78)	(49)

Note: The quoted allowable radial load is the value at a position 0.79in (20mm.) from the mounting surface.

†Some motor dimensions vary for motors with the optional shaft seal: See p.38 for details.

Specified Tolerances				
Dimension	*ΦS		**ΦLB	
Unit	Diameter	Tolerance	Diameter	Tolerance
in	0.3150	+0.0000-0.0004	1.9685	+0.0000 -0.0010
mm	8.000	+0.000 -0.009	50.000	+0.000 -0.025

Encoder Plug

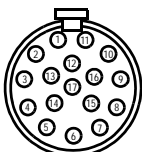

SRUC 17GMRCN087 (Interconnector)

Incremental Terminal Specifications

Pin No.	Description	Color
1*	Battery -	—
2*	Battery * (3.6V)	—
3	Data +	Blue
4	Data-	Blue/White
5 - 7, 10 - 17	Free	—
8	+5V (Power Supply)	Red
9	0V (Power Supply)	Black
Connector Case	FG (Frame Ground)	Shield wire

*Note: Incremental Terminal pins number 1 and 2 are connectors used for 16-bit absolute encoder option only.

Mating Connector: SPNA17HFRON16900E3 (Interconnector)

Motor Plug

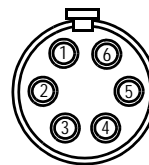

SRUC 06JM5CN236 (Interconnector)

Motor Wiring Specifications

Pin Number	Description	Color
1	Phase U	Red
2	Phase V	White
3	Phase W	Blue
6	FG (Frame Ground)	Green/Yellow

Mating Connector: SPNA06KFSDN169 (Interconnector)

100/200V Single-phase Sigma II Servo Systems

- 200W (0.27hp), 400W (0.53hp)

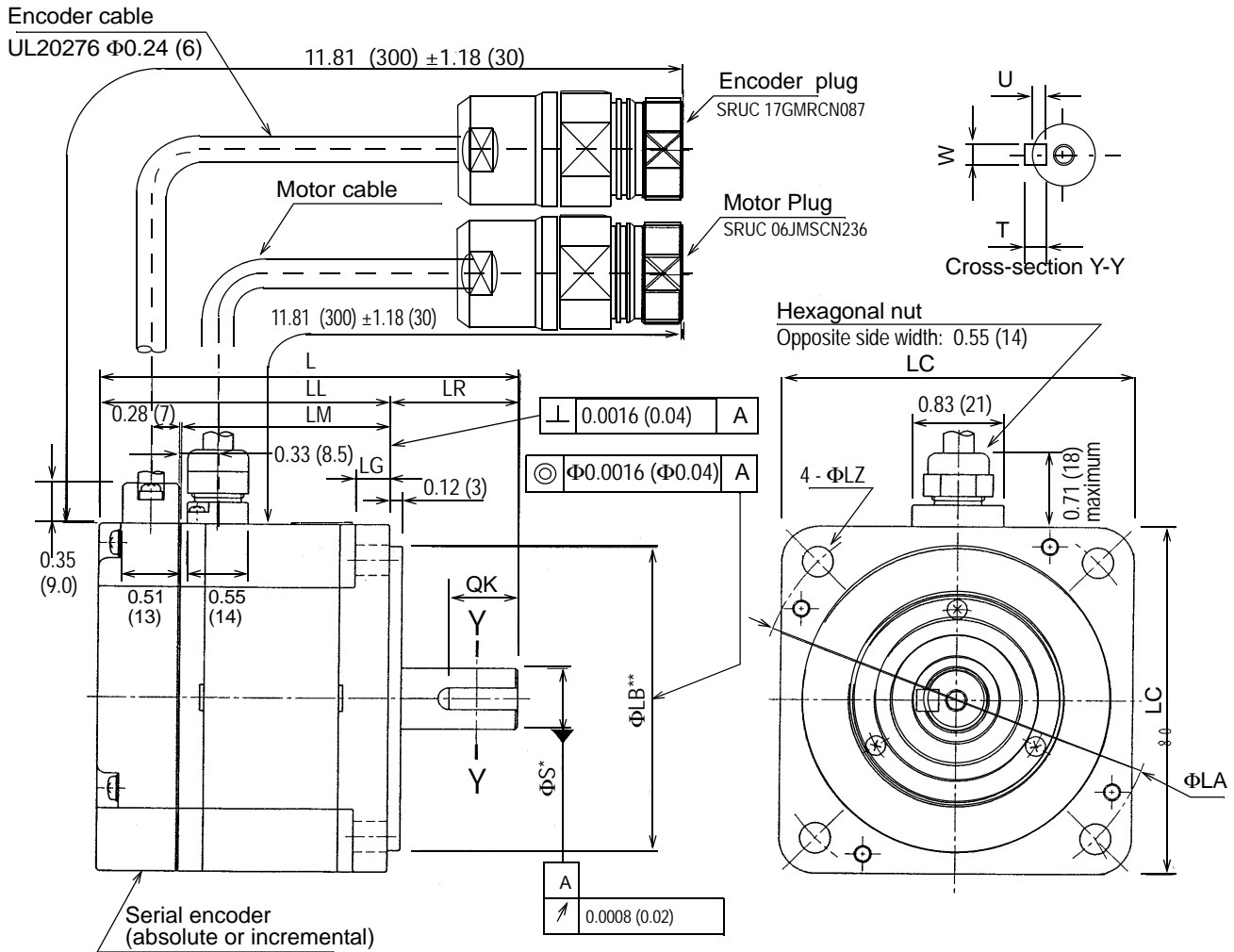

SGMPH Servomotors

Type SGMPH-	L	LL	LM	LR	LG	LC	ΦLA	ΦLZ	ΦS*	ΦLB**	Key				Voltage V	Output W (hp)	Torque in·lb (N·m)	Time Rating	Rated Speed (rpm)	Approx Mass lb (kg)	Allowable Radial Load lb (N)	Allowable Thrust Load lb (N)
											QK	U	W	T								
02□□E41D	3.82 (97)	2.64 (67)	1.89 (48.1)	1.18	0.31 (8)	3.15 (80)	3.54 (90)	0.28 (7)	0.551 (14)	2.76 (70)	0.63 (16)	0.12 (3)	0.20 (5)	0.20 (5)	200	200 (0.27)	5.64 (0.637)	Continuous	3000	3.09 (1.4)	55.1 (245)	15.4 (68)
04□□E41D	4.61 (117)	3.46 (87)	2.68 (68.1)	3.0	0.31 (8)	3.15 (80)	3.54 (90)	0.28 (7)	0.551 (14)	2.76 (70)	0.63 (16)	0.12 (3)	0.20 (5)	0.20 (5)		400 (0.53)	11.2 (1.27)			4.63 (2.1)		

Note: The quoted allowable radial load is the value at a position 0.98in (25mm) from the mounting surface.

†Some motor dimensions vary for motors with the optional shaft seal: See p.38 for details.

Specified Tolerances				
Dimension	*ΦS		**ΦLB	
Unit	Diameter	Tolerance	Diameter	Tolerance
in	0.5512	+0.0000-0.0004	2.7559	+0.0000 -0.0012
mm	14.000	+0.000 -0.011	70.000	+0.000 -0.030

Interconnection Connector Specifications: See p.30.

100/200V Single-phase Sigma II Servo Systems

- 750W (1.01hp)

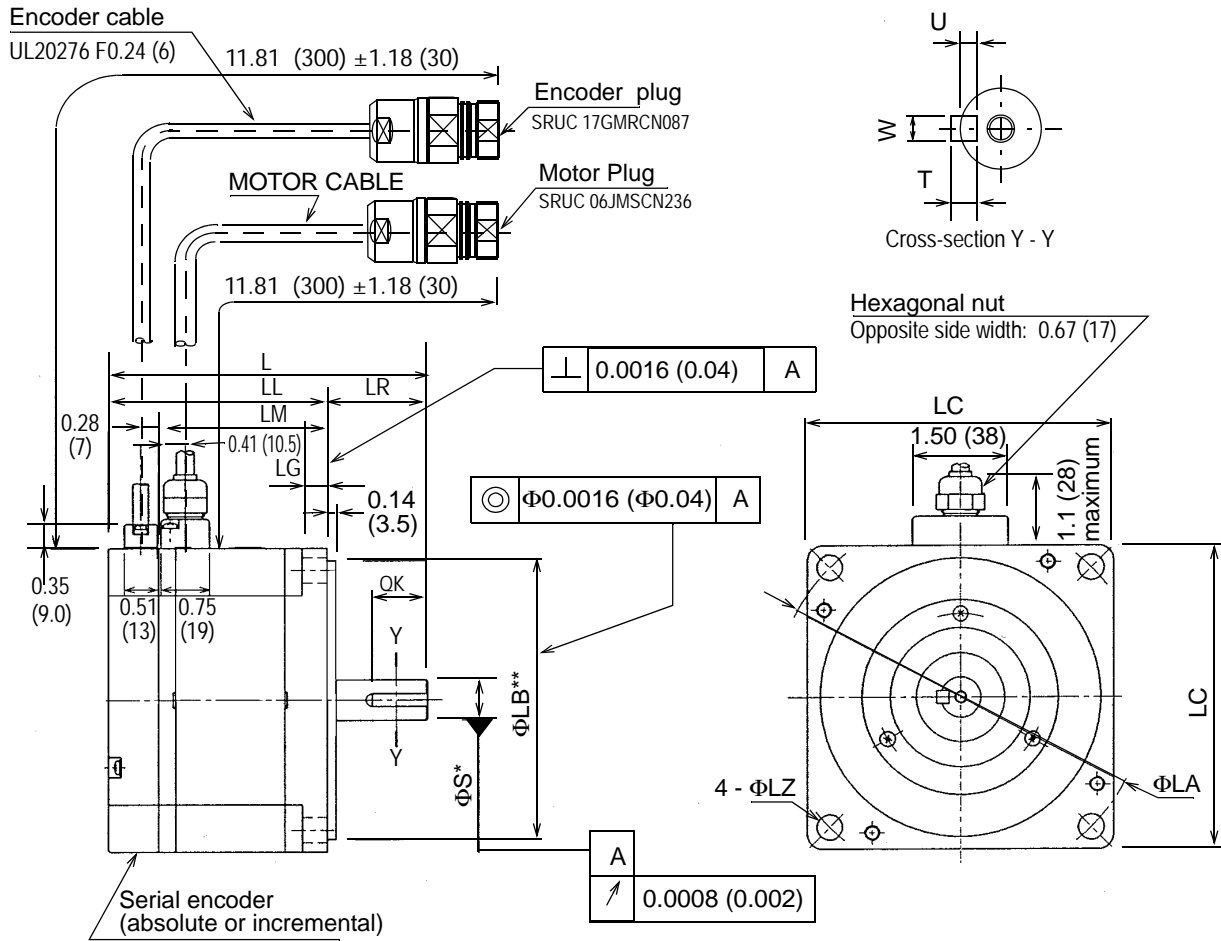

SGMPH Servomotors

Type SGMPH-	L	LL	LM	LR	LG	LC	ΦLA	ΦLZ	ΦS^*	ΦLB^{**}	Key				Voltage V	Output W (hp)	Torque in·lb (N·m)	Time Rating	Rated Speed (rpm)	Approx Mass/lb (kg)	Allowable Radial Load lb (N)	Allowable Thrust Load lb (N)
											OK	U	W	T								
08□□E41D	4.98 (126.5)	3.41 (86.5)	2.63 (66.7)	1.57 (40)	0.39 (10)	4.72 (120)	5.71 (145)	0.39 (10)	0.63 (16)	4.33 (110)	0.87 (22)	0.12 (3)	0.20 (5)	0.20 (5)	200	750 (1.01)	21.1 (2.39)	Continuous	3000	9.26 (4.2)	88.1 (392)	33.0 (147)

Note: The quoted allowable radial load is the value at a position 1.38in (35mm) from the motor mounting surface.

†Some motor dimensions vary for motors with the optional shaft seal: See p.38 for details.

Specified Tolerances				
Dimension	* ΦS		** ΦLB	
Unit	Diameter	Tolerance	Diameter	Tolerance
in	0.6299	+0.0000-0.0004	4.3307	+0.0000 -0.0014
mm	16.000	+0.000 -0.011	110.000	+0.000 -0.035

Interconnection Connector Specifications: See p.30.

100/200V Single-phase Sigma II Servo Systems

- 1500W (2.0hp)**

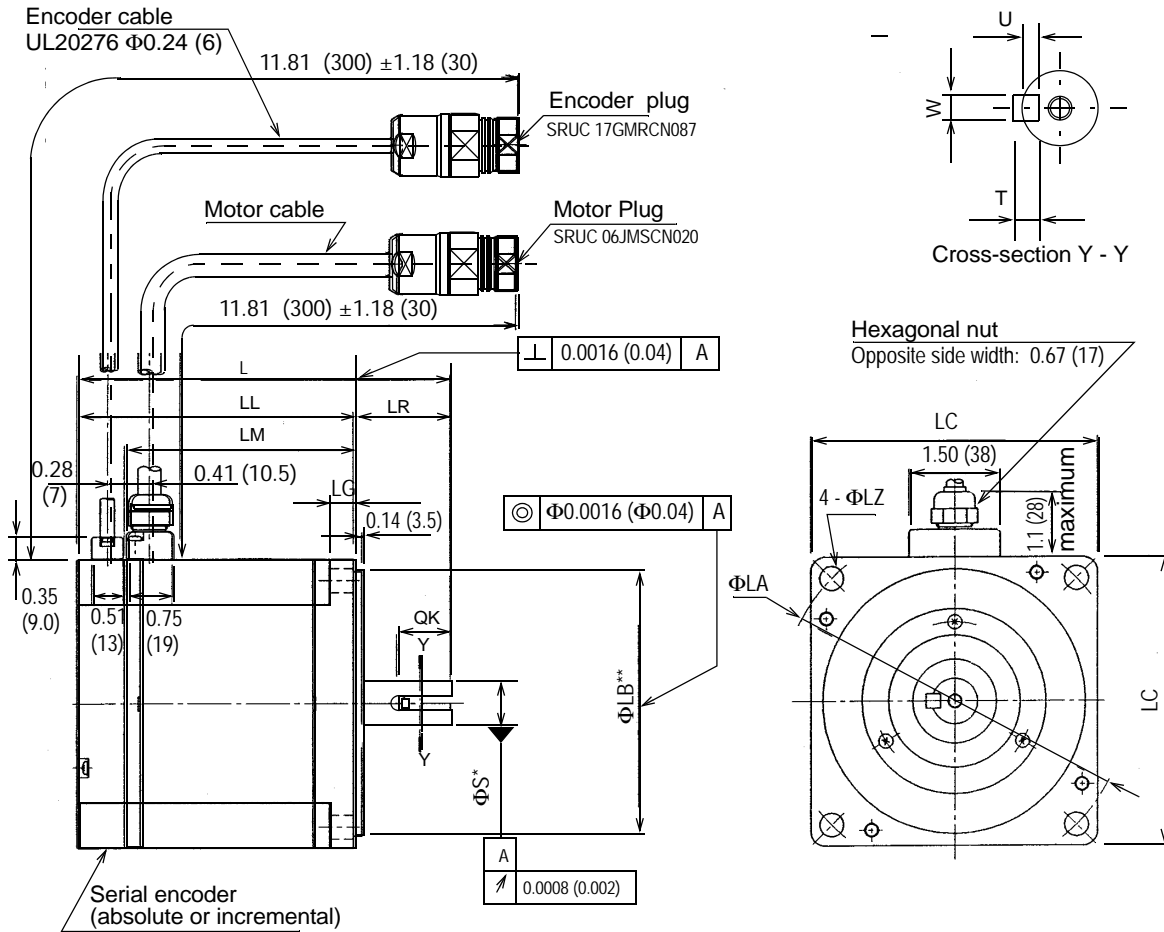

SGMPH
Servomotors

Type SGMPH-	L	LL	LM	LR	LG	LC	$\Phi L A$	$\Phi L Z$	ΦS^*	$\Phi L B^{**}$	Key				Voltage V	Output W (hp)	Torque in-lb (N-m)	Time Rating	Rated Speed (rpm)	Approx Mass lb (kg)	Allowable Radial Load lb (N)	Allowable Thrust Load lb (N)
											QK	U	W	T								
15□□E41D	6.08 (154.5)	4.51 (114.5)	3.73 (94.7)	1.57 (40)	0.39 (10)	4.72 (120)	5.71 (145)	0.39 (10)	0.75 (19)	4.33 (110)	0.87 (22)	0.14 (3.5)	0.24 (6)	0.24 (6)	200	1500 (2.0)	42.1 (4.77)	Continuous	3000	14.55 (6.6)	110 (490)	33.0 (147)

Note: The quoted allowable radial load is the value at a position 1.38in (35mm) from the motor mounting surface.

†Some motor dimensions vary for motors with the optional shaft seal: See p.38 for details.

Specified Tolerances				
Dimension	ΦS^*		$\Phi L B^{**}$	
Unit	Diameter	Tolerance	Diameter	Tolerance
in	0.7480	+0.0000-0.0005	4.3307	+0.0000-0.0014
mm	19.000	+0.000-0.013	110.000	+0.000-0.035

Interconnection Connector Specifications

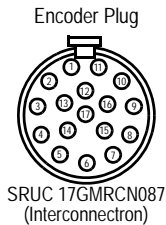

Incremental Terminal Specifications		
Pin Number	Description	Color
1*	Battery -	—
2*	Battery * (3.6V)	—
3	Data +	Blue
4	Data -	Blue/White
5 - 7, 10 - 17	Free	—
8	+5V (Power Supply)	Red
9	0V (Power Supply)	Black
Connector Case	FG (Frame Ground)	Shield wire

*Note: Incremental Terminal pins number 1 and 2 are connectors used for 16-bit absolute encoder option only.

Mating Connector: SPNA17HFRON16900E3
(Interconnector)

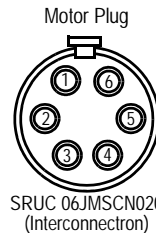

Motor Wiring Specifications		
Pin No.	Description	Color
1	Phase U	Red
2	Phase V	White
3	Phase W	Blue
6	FG (Frame Ground)	Green/Yellow

Mating Connector: SPNA06KFSDN169
(Interconnector)

(2) 13-Bit Incremental or 16-Bit Absolute Encoder, with Brake

- Note:
1. The keyway complies with JIS B1301-1976 (precision). A straight key is supplied.
 2. The electromagnetic brake is only to hold the load in position and cannot be used to stop the motor.
 3. Conforms to the IP67 enclosure, excluding the shaft (optional shaft seal available).

• 100W (0.13hp)

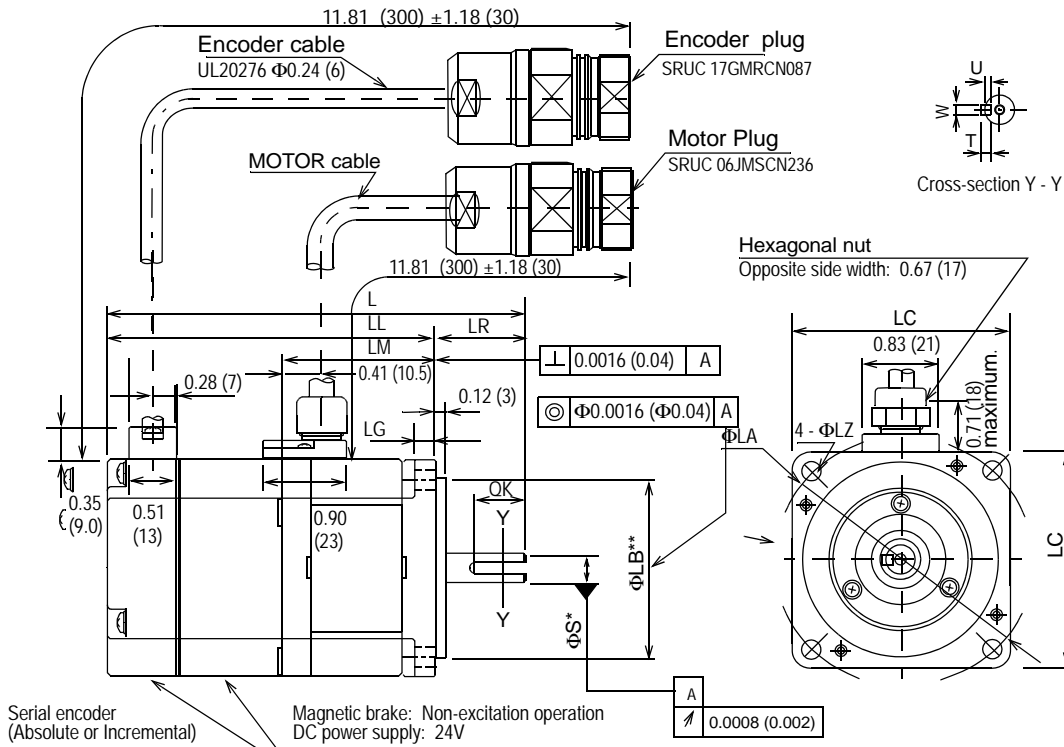

Type SGMPH-	L	LL	LM	LR	LG	LC	ΦLA	ΦLZ	ΦS*	ΦLB**	Key				Voltage (V)	Output W (hp)	Torque in-lb (N-m)	Time Rating	Rated Speed (rpm)	Approx Mass (kg)	Allowable Radial Load (lb (N))	Allowable Thrust (lb (N))
											QK	U	W	T								
01□E4CD	4.57 (116)	3.58 (91)	1.67 (42.5)	0.98 (25)	0.24 (6)	2.36 (60)	2.76 (70)	0.22 (5.5)	0.315 (8)	1.968 (50)	0.55 (14)	0.071 (1.8)	0.12 (3)	0.12 (3)	200	100 (0.13)	2.81 (0.318)	Continuous	3000	1.5 (0.7)	17.5 (78)	11.0 (49)

Note: The quoted allowable radial load is the value at a position 0.79in (20mm) from the motor mounting surface.

†Some motor dimensions vary for motors with the optional shaft seal: See p.38 for details.

Specified Tolerances				
Dimension	*ΦS		**ΦLB	
Unit	Diameter	Tolerance	Diameter	Tolerance
in	0.3150	+0.0000-0.0004	1.9685	+0.0000 -0.0010
mm	8.000	+0.000 -0.009	50.000	+0.000 -0.025

Interconnection Connector Specifications



Incremental Terminal Specifications		
Pin Number	Description	Color
1*	Battery -	-
2*	Battery * (3.6V)	-
3	Data +	Blue
4	Data-	Blue/White
5 - 7, 10 - 17	Free	-
8	+5V (Power Supply)	Red
9	0V (Power Supply)	Black
Connector Case	FG (Frame Ground)	Shield wire

*Note: Incremental Terminal pins number 1 and 2 are connectors used for 16-bit absolute encoder option only.

Mating Connector: SPNA17HFRON16900E3 (Interconnector)

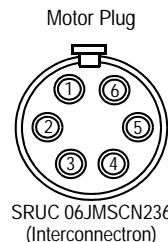

Motor Wiring Specifications		
Pin Number	Description	Color
1	Phase U	Red
2	Phase V	White
3	Phase W	Blue
4	Holding Brake	Black
5	Holding Brake	Black
6	FG (Frame Ground)	Green/Yellow

Mating Connector: SPNA06KFSDN169 (Interconnector)

100/200V Single-phase Sigma II Servo Systems

- 200W (0.27hp), 400W (0.53hp)

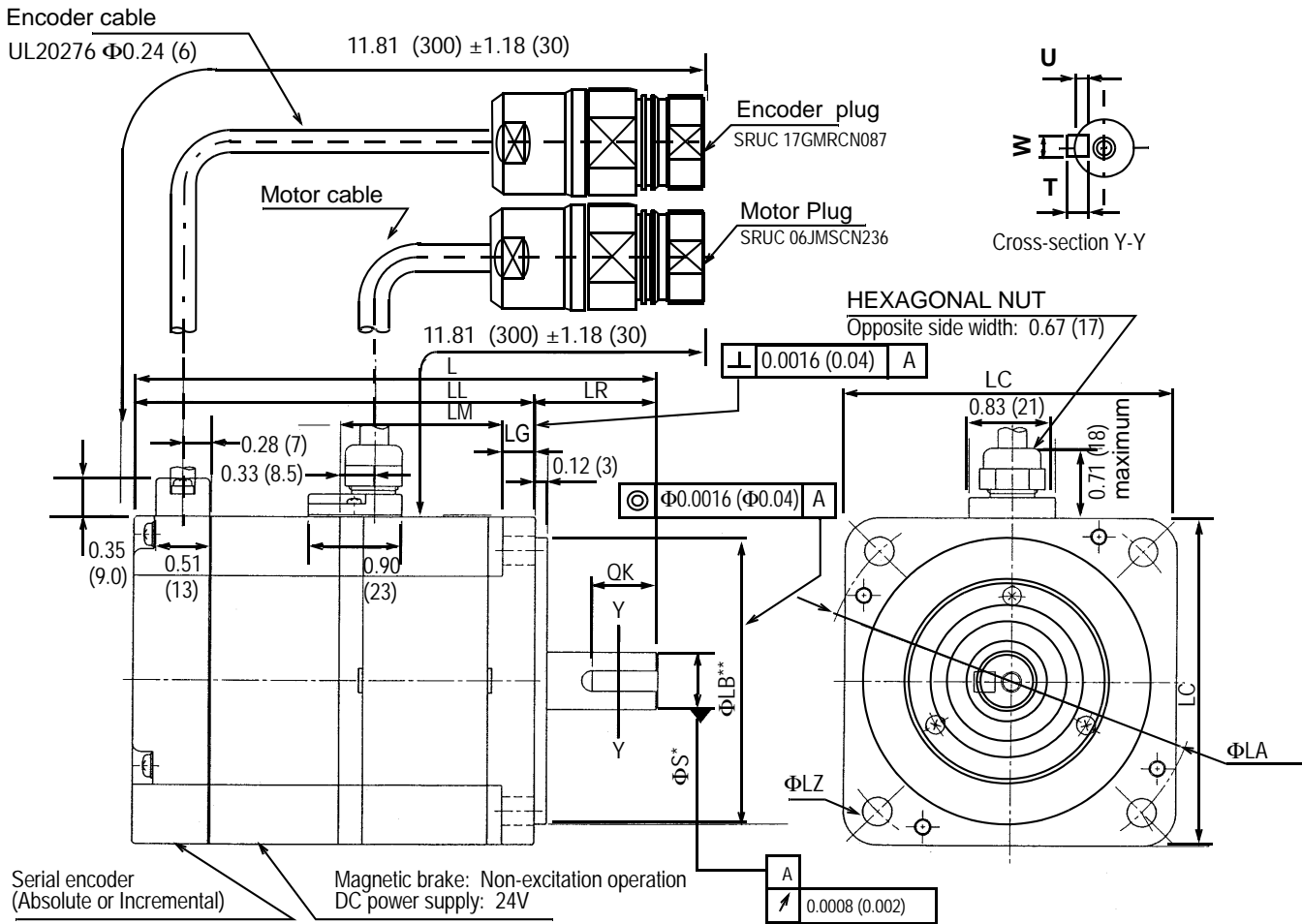

SGMPH Servomotors

Type SGMPH-	L	LL	LM	LR	LG	LC	ΦLA	ΦLZ	ΦS*	ΦLB**	Key				Voltage V	Output W (hp)	Torque in·lb (N·m)	Time Rating	Rated Speed (rpm)	Approx Mass lb (kg)	Allowable Radial Load lb (N)	Allowable Thrust Load lb (N)
											QK	U	W	T								
02□□E4CD	5.06 (128.5)	3.88 (98.5)	1.89 (48.1)	1.18 (30)	0.31 (8)	3.15 (80)	3.54 (90)	0.28 (7)	0.551 (14)	2.756 (70)	0.63 (16)	0.12 (3)	0.20 (5)	0.20 (5)	200	200 (0.27)	5.64 (0.637)	Continuous	3000	4.2 (1.9)	55.1 (245)	15.29 (68)
04□□E4CD	5.85 (148.5)	4.67 (118.5)	2.68 (68.1)											400	400 (0.53)	11.2 (1.27)			5.7 (2.6)			

Note: The quoted allowable radial load is the value at a position 0.98in (25mm) from the motor mounting surface.

†Some motor dimensions vary for motors with the optional shaft seal: See p.38 for details.

Specified Tolerances				
Dimension	*ΦS		**ΦLB	
Unit	Diameter	Tolerance	Diameter	Tolerance
in	0.5512	+0.0000-0.0004	2.7559	+0.0000 -0.0012
mm	14.000	+0.000 -0.011	70.000	+0.000 -0.030

Interconnection Connector Specifications: See p.33.

100/200V Single-phase Sigma II Servo Systems

- 750W (1.01hp)

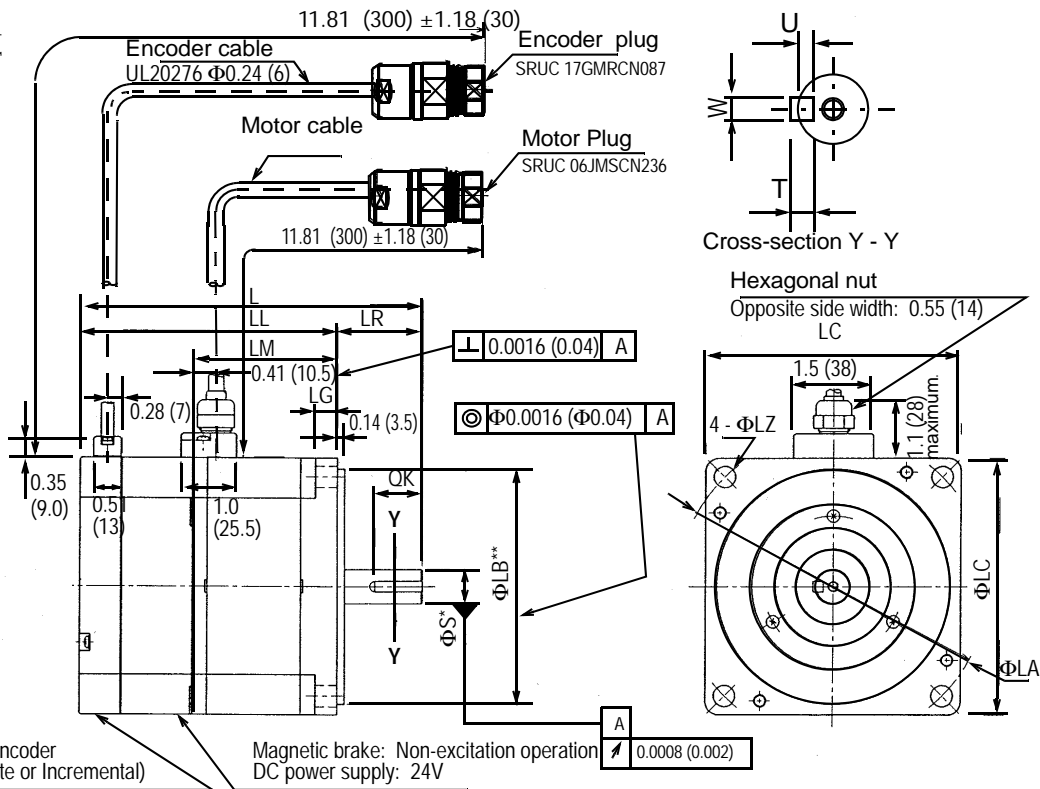

SGMPH Servomotors

Type SGMPH-	L	LL	LM	LR	LG	LC	ΦLA	ΦLZ	ΦS*	ΦLB**	Key				Voltage V	Output W (hp)	Torque in-lb (N·m)	Time Rating	Rated Speed (rpm)	Approx Mass lb (kg)	Allowable Radial Load lb (N)	Allowable Thrust Load lb (N)
											OK	U	W	T								
08□□E4CD	6.42 (163)	4.84 (123)	2.63 (66.7)	1.57 (40)	0.39 (10)	4.72 (120)	5.71 (145)	0.39 (10)	0.63 (16)	4.33 (110)	0.87 (22)	0.12 (3)	0.20 (5)	0.20 (5)	200	750 (1.01)	21.15 (2.39)	Continuous	3000	12.6 (5.7)	88.1 (392)	33.0 (147)

Note: The quoted allowable radial load is the value at a position 1.38in (35mm) from the motor mounting surface.

†Some motor dimensions vary for motors with the optional shaft seal: See p.38 for details.

Specified Tolerances				
Dimension	*ΦS		**ΦLB	
Unit	Diameter	Tolerance	Diameter	Tolerance
in	0.6299	+0.0000-0.0004	4.3307	+0.0000 -0.0014
mm	16.000	+0.000 -0.011	110.000	+0.000 -0.035

Interconnection Connector Specifications: See p.33.

100/200V Single-phase Sigma II Servo Systems

- 1500W (2.0hp)

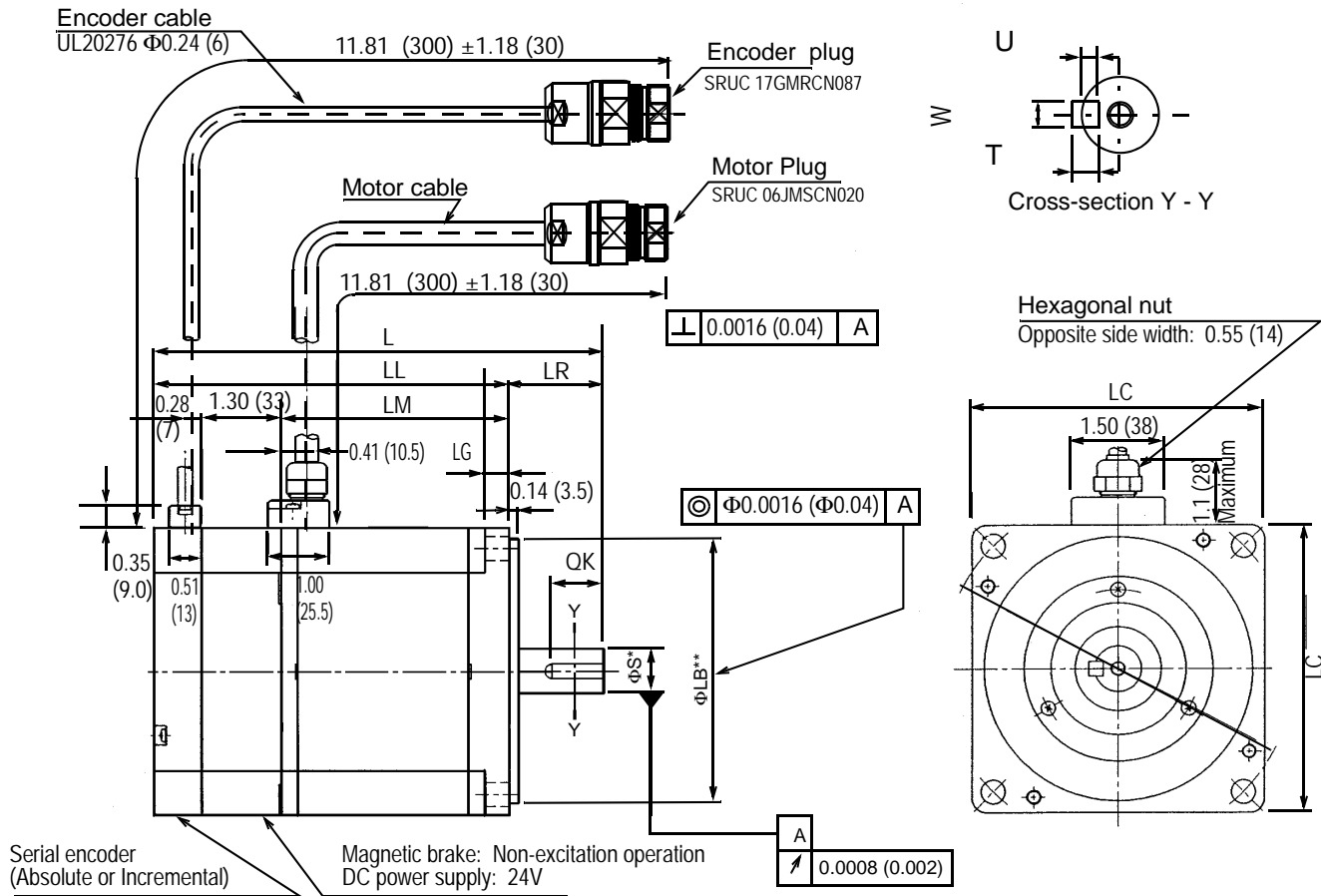

SGMPH Servomotors

Type SGMPH-	L	LL	LM	LR	LG	LC	ΦLA	ΦLZ	ΦS^*	ΦLB^{**}	Key				Voltage V	Output W (hp)	Torque in-lb (N·m)	Time Rating	Rated Speed (rpm)	Approx Mass lb (kg)	Allowable Radial Load lb (N)	Allowable Thrust Load lb (N)
											OK	U	W	T								
15□□E4CD	7.40 (188)	5.83 (148)	3.73 (94.7)	1.57 (40)	0.39 (10)	4.72 (120)	5.71 (145)	0.39 (10)	0.75 (19)	4.33 (110)	0.87 (22)	0.14 (3.5)	0.24 (6)	0.24 (6)	200	1500 (2.02)	42.1 (4.77)	Contin- uous	3000	17.9 (8.1)	110 (490)	33.0 (147)

Note: The quoted allowable radial load is the value at a position 1.38in (35mm) from the motor mounting surface.

†Some motor dimensions vary for motors with the optional shaft seal: See p.38 for details.

Specified Tolerances				
Dimension	$^*\Phi S$		$^{**}\Phi LB$	
Unit	Diameter	Tolerance	Diameter	Tolerance
in	0.7480	+0.0000-0.0005	2.7559	+0.0000 -0.0014
mm	19.000	+0.000 -0.013	70.000	+0.000 -0.035

Interconnection Connector Specifications

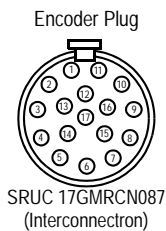

Incremental Terminal Specifications		
Pin Number	Description	Color
1*	Battery -	—
2*	Battery + (3.6V)	—
3	Data +	Blue
4	Data -	Blue/White
5 - 7, 10 - 17	Free	—
8	+5V (Power Supply)	Red
9	0V (Power Supply)	Black
Connector Case	FG (Frame Ground)	Shield wire

*Note: Incremental Terminal pins number 1 and 2 are connectors used for 16-bit absolute encoder option only.

Mating Connector: SPNA17HFRON16900E3
(Interconnector)

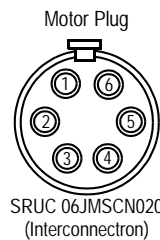

Motor Wiring Specifications		
Pin No.	Description	Color
1	Phase U	Red
2	Phase V	White
3	Phase W	Blue
4	Holding Brake	Black
5	Holding Brake	Black
6	FG (Frame Ground)	Green/Yellow

Mating Connector: SPNA06KFSDN169
(Interconnector)

Dimension Modifications for Motors with Optional Shaft Seal

SGMPH Servomotors

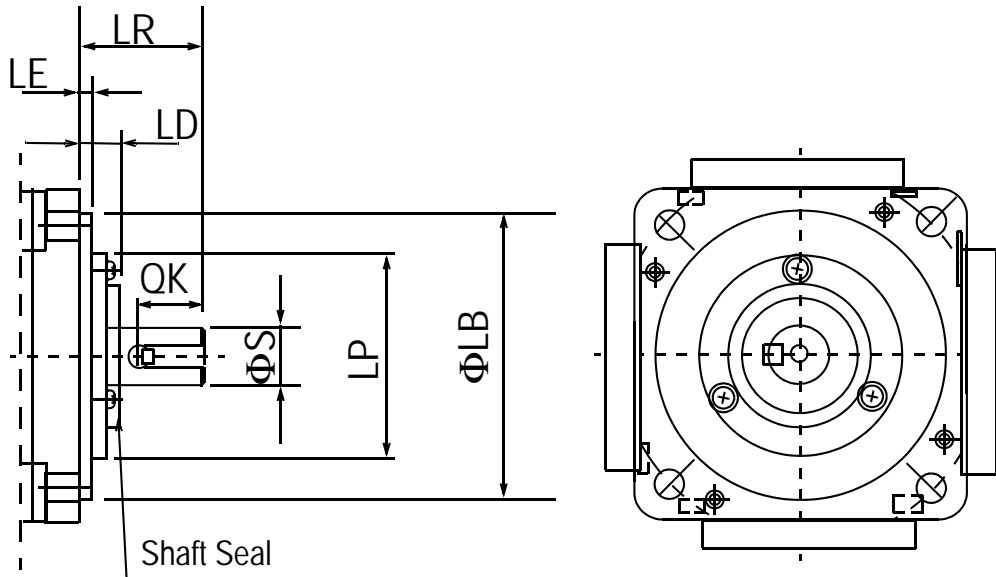

Type SGMPH-	QK	ΦLB*	ΦS*	LE	LR	LD	ΦLP
01	0.55 (14)	1.97 (50)	0.31 (8)	0.12 (3)	0.98 (25)	0.28 (7)	1.54 (39)
02	0.64 (16)	2.76 (70)	0.55 (14)		1.18 (30)	0.39 (10)	1.93 (49)
04				0.14 (3.5)	1.57 (40)	0.41 (10.5)	3.03 (77)
08	0.63 (16)						
15	0.75 (19)						

*Refer to the following table for tolerances for diameters LB and S.

Specified Tolerances				
Dimension	*ΦS		**ΦLB	
Unit	Diameter	Tolerance	Diameter	Tolerance
in	0.3150	+0.0000-0.0004	1.9685	+0.0000 -0.0010
	0.5512	+0.0000-0.0004	2.7559	+0.0000 -0.0014
	0.6299	+0.0000-0.0004	4.3307	+0.0000 -0.0014
	0.7480	+0.0000-0.0005		
mm	8.000	+0.000 -0.009	50.000	+0.000 -0.025
	14.000	+0.000 -0.011	70.000	+0.000 -0.035
	16.000	+0.000 -0.011	110.000	+0.000 -0.035
	19.000	+0.000 -0.013		

Torque Reduction Factor for SGMPH motors equipped with a shaft seal:

Servo Motor Model	01	02	04	08	15
Torque Reduction Factor	90%	90%	95%	95%	95%

For Example: The SGMPH-01 continuous and peak torque rating should be reduced to 90% of the listed catalog specification.

To specify a motor with a shaft seal, refer to the motor part number explanation on the following page.

Selecting Your SGMPH Sigma II Servo System

First, select the Sigma II servomotor suited for your application using SigmaSize: the Yaskawa servomotor sizing software, available at no charge. (Request SigmaSize software via e-mail, at: literature@yaskawa.com).

Use the diagram below to locate and identify the components of your system. Each item is letter-coded and cross-referenced in the option tables on the following pages.

System Configuration

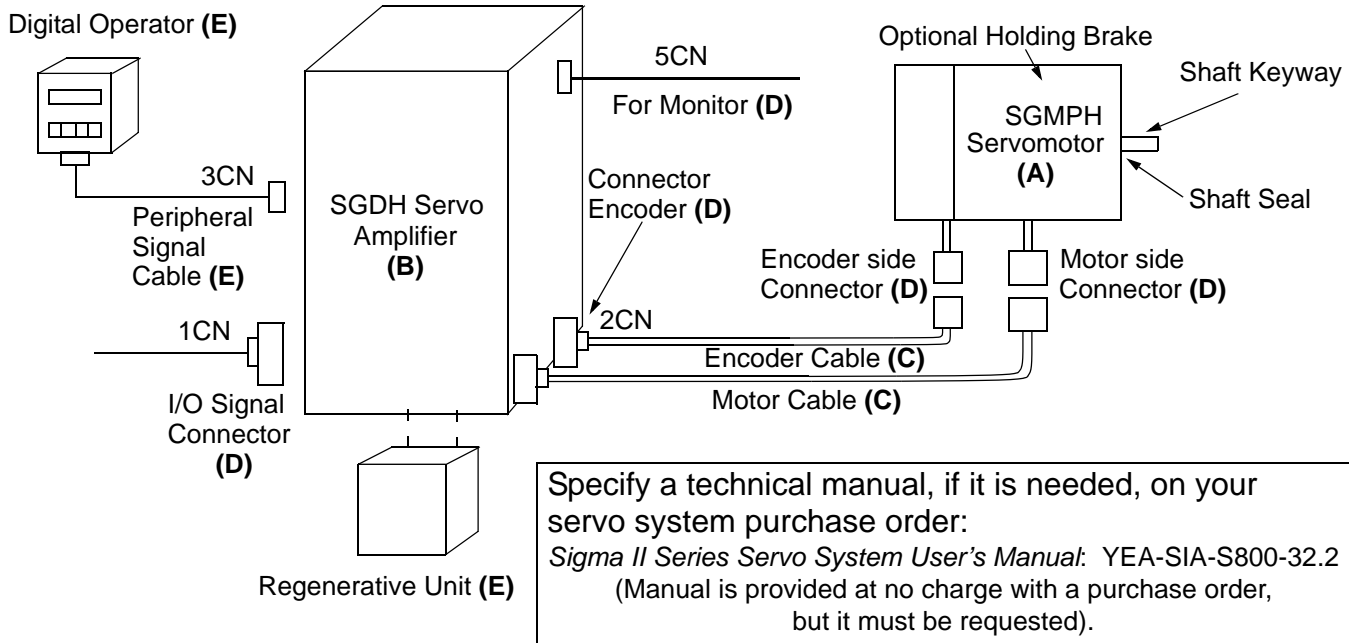

SGMPH
Servomotors

Model Number Designation

SGMPH - 01 A A E 4 1D

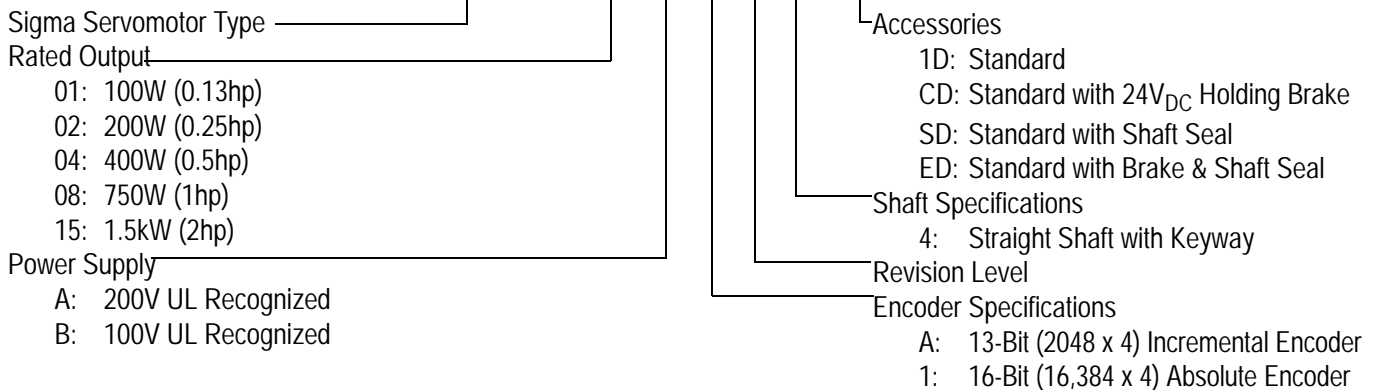

100/200V Single-phase Sigma II Servo Systems

Servomotor & Amplifier Selection

Use the table below to select the appropriate SGMPH Sigma II servomotor and amplifier.
(Refer to the motor model # designation on the previous page specifying the available modification to motor construction/features.)

Description	Peak Torque (oz · in)	Rated Torque (oz · in)	Motor Inertia (oz · in · s ² x10 ⁻³)	Motor MODEL # (A)	Amplifier MODEL # (B)*		Motor & Amplifier Item Class	
					1-Phase SGDH-	3-Phase SGDH-		
200V 13-Bit Incremental Encoder Straight Shaft with Keyway 5000rpm Pre-wired with Heavy Duty Connectors	135	45.1	0.917	SGMPH-01AAE41D	01AE	—	Stock	
			1.46	SGMPH-01AAE4CD				
	270	90.1	2.96	SGMPH-02AAE41D	02AE	—		
			4.35	SGMPH-02AAE4CD				
	542	181	4.92	SGMPH-04AAE41D	04AE	—		
			6.31	SGMPH-04AAE4CD				
	1010	338	29.9	SGMPH-08AAE41D	08AE-S	08AE		
			35.7	SGMPH-08AAE4CD				
	2027	676	57.1	SGMPH-15AAE41D	15AE-S	15AE		
			67.8	SGMPH-15AAE4CD				
	100V, 1-Phase 13-Bit Incremental Encoder Straight Shaft with Keyway 5000rpm Pre-wired with Heavy Duty Connectors	135	45.1	0.917	SGMPH-01BAE41D	01BE		—
				1.46	SGMPH-01BAE4CD			
270		90.1	2.96	SGMPH-02BAE41D	02BE	—		
			4.35	SGMPH-02BAE4CD				
542		181	4.92	SGMPH-04AAE41D	04FE	—		
			6.31	SGMPH-04AAE4CD				





Notes: 24V_{DC} brakes for SGMPH Sigma II servomotors are standard. Contact a local source for 24V_{DC} power supplies. Motor power and encoder cables are factory pre-wired with approximately 13" lead length with heavy duty mating connectors. Use the tables on the following page to specify mating connectors and/or various cable lengths. For technical information, request Yaskawa manual number YEA-SIA-S800-32.2.

* For more detailed SGDH amplifier specifications and dimensions, refer to pages 99 to 112.

SGMPH Servomotors

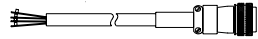
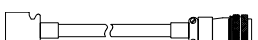
Pre-wired Cable Selection

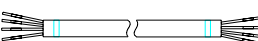
Use the table below to select pre-wired cables for your SGMPH Sigma II servomotor.

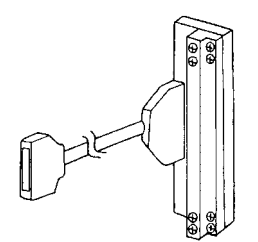
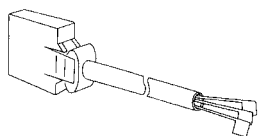
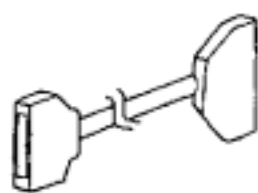
Cable Description (C)		Motor Size (kW)	Part Number*	Comments	Item Class		
Power Cable with Interconnectron Connectors (without Brake)		0.1, 0.2, 0.4, 0.8	B4ICE-□□(A)	These UL and CE compliant cables are available in five lengths. Use two digits in the part number's last place: 03: 3m 05: 5m 10: 10m (standard) 15: 15m 20: 20m	Stock**		
		1.5	B5ICE-□□(A)				
Power Cable with Interconnectron Connectors (with Brake) (IP67)		0.1, 0.2, 0.4, 0.8	B4IBCE-□□(A)				
		1.5	B5IBCE-□□(A)				
Encoder Cable with Interconnectron Connector (incremental or absolute) (IP67)		All	A1ICE-□□(A)			These cables are available in any length. For example, to order one FR-RMCT-SB cable, 16m long, specify: quantity: 16 part no.: FR-RMCT-SB	Stock**
Encoder Cable (for applications up to 20m) Only for Solder Connections			FR-RMCT-SB				
Encoder Cable (for applications from >20 to <50m) Only for Solder Connections			UL20276-SB				
Input/Output 1CN Cable & Transition Terminal Block			JUSP-TA50P	35mm DIN rail mountable; the cable length is 0.5 meters.			
Input/Output 1CN Cable with Pigtail Leads			JZSP-CKI01-□(A)	Use the following key to specify required cable length (last digit of part number): 1: 1m (standard) 2: 2m 3: 3m			
Input/Output 1CN Cable Cable with Female D-Sub output Connector***			JZSP-CKI0D-□□	Use the following key to specify required cable length (last two digits of the part number): D50: 0.5m 01: 1m (standard) 02: 2m 03: 3m			

* The "(A)" at the end of the cable part number is the revision level. Revision level may be changed prior to catalog reprinting.

** Standard cable lengths are Stock items; non-standard cable lengths are Limited Stock items.

*** 50 Pin Female D-Sub output connector mates to customer supplied third party terminal block. (e.g., Wago #289-449, Weidmuller #919658, Phoenix #2283647, Amphenol/Sine #20-51039, and many others)

Connector Selection

Use the table below to select mating connectors or kits for your SGMFH Sigma II servomotor.

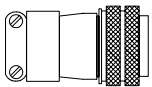
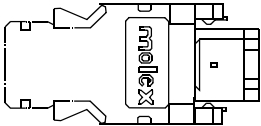
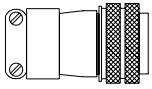
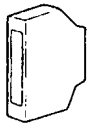
Connector Description (D)		Motor Size (kW)	Part Number	Comments	Item Class
Interconnectron Connector for Motor Power Cable (with or without Brake) (IP67)		0.1, 0.2, 0.4, 0.8, 1.5	FIN07S-B2	Solder Cup	Stock
2CN Amplifier Mating Connector			JZSP-CMP9-1	—	
Interconnectron Connector for Encoder Cable (incremental or absolute encoder) (IP67)			FIN17C-A2	Gauge: 24 - 18AWG Requires Crimp Tool B150 and positioner.	
1CN Mating Connector		All	JZSP-CKI9	—	
Interconnectron Crimp Tool	—		B150	—	Limited Stock
Positioner	—		B055/A	—	

Peripheral Device Selection

Use the table below to select peripheral devices for your SGMPH Sigma II servomotor.

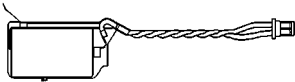
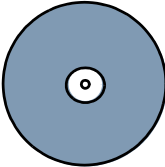
Component	Description (E)	Part Number	Comments	Item Class
Hand-held Digital Operator Panel		JUSP-OP02A-1 and JZSP-CMS00-1	Portable unit with 1m adapter cable for Sigma II	Stock
Absolute Encoder Battery		JZSP-BA01	3.6V, 1000mAh (lithium battery)	
Software Interface Cable	—	YS-12	Pre-wired 2.0m cable with 9-pin connector	
SigmaWin+ Software		JZSP-WP0001	Minimum Recommended System Requirements Pentium 200 MHz, 64MB RAM, 200MB hard drive, CDROM Drive, RS-232 or RS-422 port, Screen resolution 800x600 w/ 256 colors, and Windows 95,98,NT4.0,2000,ME. (Windows XP planned)	
Individual External Regenerative Unit	For: SGDH-01AE SGDH-02AE SGDH-04AE SGDH-08AE SGDF-08AE-S amps For: SGDH-15AE SGDH-15AE-S	RH12050ohmJ RH500N25_ohmK	These are general purpose regenerative units.* Caution: Proper set-up is necessary to avoid equipment damage.	
DC Reactor (for suppressing harmonics in the power supply)	For 200V: SGDH-01AE SGDH-02AE SGDH-04AE SGDH-08AE SGDF-08AE-S SGDH-15AE SGDH-15AE-S For 100V: SGDH-01BE SGDH-02BE	X5071 X5070 X5069 X5061 X5079 X5060 X5078 X5063 X5062	—	Limited Stock

* For an alternate solution, specify the individual resistor part number RH500N25_OHMK in necessary series or parallel connection. Refer to the SGDH servo amplifier section of this catalog for additional specifications, and the *Sigma II Series Servo System User's Manual* (YEA-SIA-S800-32.2) for proper resistor sizing guidelines.

NOTES:

SGMPH Gearmotors - With Incremental / Absolute Encoder

Rated Output : 100W, 200W, 400W,
750W, 1500W



For Additional Information	Page(s)
SGMPH Gearmotor Ratings & Specifications	48 - 49
SGMPH Gearmotor Dimensions	50 - 51
SGMPH Gearmotor Selection/Ordering Information	52 - 55
SGDH Ratings & Specifications	99 - 100
SGDH Dimensions	101 - 112

Design Features

1. Compact Construction

- Easy to install - pre-engineered and pre-assembled
- Ideal for cyclic and reversing applications
- Fits in limited mounting space
- Planetary gear geometry allowing high output torques in a compact package

2. Torque

- 40.9 to 3540in • lb peak torque
- Cost-effective solution for low speed and high torque applications
- Gear ratios - 5:1 to 100:1 in some sizes
- High torsional stiffness and low backlash
- Lubrication is self-replenishing to ensure long life

3. Encoders

- 13-Bit (2,048ppr x 4) incremental encoder (standard)
- 16-Bit (16,384ppr x 4) absolute encoder (option)

4. Enclosure

- Motor is totally enclosed, self-cooled IP67 (not including shaft)

5. Application Emphasis

- PCB drilling machines
- Robots
- Conveyors
- Packaging machines

6. Certified International Standards

- UL, cUL recognized (File #: E165827), CE compliance

Gearmotor Ratings and Specifications

GEARMOTOR Part Number	Rated Torque (in • lb)	Peak Torque (in • lb)	Rated Speed (rpm)	Maximum Speed (rpm)	Speed N1 (rpm)	Torque T1 (in • lb)	Torque T2 (in • lb)	Amplifier Model Number
								Analog Input SGDh-
SG05SA-PE01□□	13.67	40.93	600	1000	900	8.59	34.34	01□□
SG10SA-PE01□□	27.34	81.84	300	500	450	17.17	68.68	
SG25SA-PE01□□	66.95	200.39	120	200	180	42.04	168.16	
SG50SA-PE01□□	133.89	283.00	60	100	90	84.08	336.32	
SG1ASA-PE01□□	267.78	637.00	30	50	45	168.16	672.65	
SG05SA-PE02□□	27.34	81.84	600	1000	1000/600	17.17	81.8/36.2*	02□□
SG10SA-PE02□□	54.68	163.69	300	500	500/300	34.34	163.7/72.4*	
SG25SA-PE02□□	133.89	283.00	120	200	200/120	84.08	283/177*	
SG50SA-PE02□□	267.78	708.00	60	100	100/60	168.16	708/354.7*	
SG1ASAPE02□□	535.56	1593.00	26	48	50/30	336.32	1593/704.4*	
SG05SA-PE04□□	54.81	164.42	600	1000	640	34.34	77.27	04□□
SG10SA-PE04□□	109.61	283.00	300	500	320	68.68	154.53	
SG25SA-PE04□□	268.38	708.00	120	200	128	168.16	378.36	
SG50SA-PE04□□	536.75	1610.25	52	96	64	336.32	756.73	
SG1ASA-PE04□□	1073.50	2832.00	20	36	32	672.65	1513.45	
SG05SA-PE08□□	102.34	306.04	600	1000	640	51.51	51.51	08□□
SG10SA-PE08□□	204.67	612.07	300	500	320	103.02	103.02	
SG25SA-PE08□□	501.13	1498.63	104	192	128	252.24	252.24	
SG50SA-PE08□□	1002.25	2997.25	40	72	64	504.48	504.48	
SG05SA-PE15□□	205.16	614.50	520	960	640	103.02	103.02	15□□
SG10SA-PE15□□	410.31	1228.99	260	480	320	206.04	206.04	
SG25SA-PE15□□	1004.63	3009.13	80	144	128	504.48	504.48	
SG50SA-PE15□□	2009.25	3540.00	40	72	64	1008.97	1008.97	

* Values for 100V Gearmotor

- Note:
1. These performance ratings apply when duty cycles are 60% or less, and when the gearmotor runs for 1,000 cycles per hour or less. Contact your Yaskawa representative when duty cycles exceed 60%, and when the gearmotor runs for more than 1,000 cycles per hour.
 2. Rated Speed is at 20°C ambient temperature. Reduce Rated Speed by 20% at 40°C ambient temperature.
 3. For right-angle gearmotors, please consult the factory for availability.

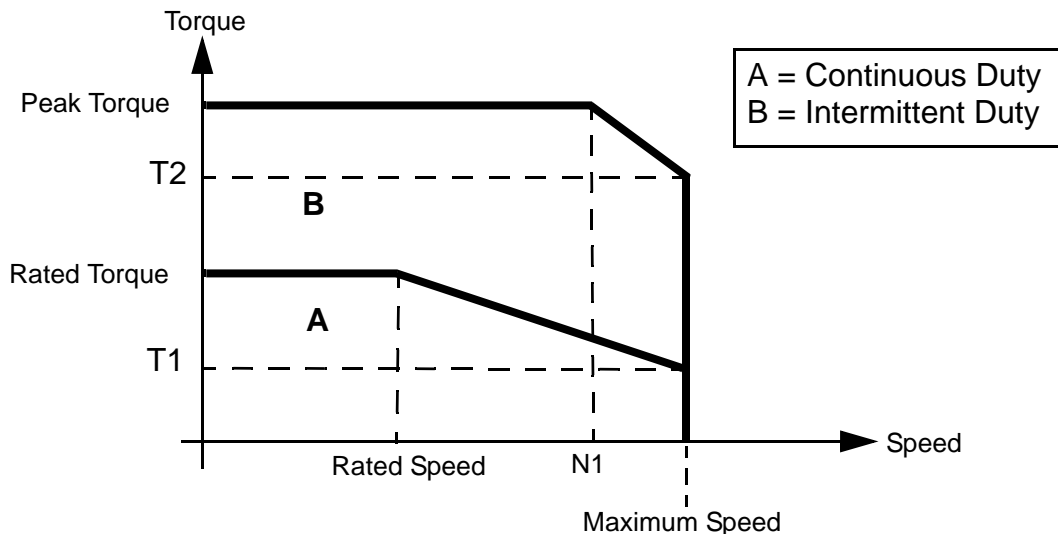

Gearmotor Mechanical Ratings

GEARMOTOR Part Number	Gearhead Backlash (arc min)	Gearhead Maximum Radial Load (lbf)	Gearhead Maximum Axial Load (lbf)	Gearhead Inertia (in • lb • s ²)	Gearmotor Weight (lb)	
SG05SA-PE01□□	<10	146	158	0.000052	3.24	
SG10SA-PE01□□						
SG25SA-PE01□□		326	349		0.00025	6.39
SG50SA-PE01□□						
SG1ASA-PE01□□						
SG05SA-PE02□□	<10	326	349	0.00025	7.28	
SG10SA-PE02□□						
SG25SA-PE02□□		540	428		0.0016	14.34
SG50SA-PE02□□						
SG1ASA-PE02□□						
SG05SA-PE04□□	<10	326	349	0.00025	8.82	
SG10SA-PE04□□						
SG25SA-PE04□□		540	428		0.0016	15.88
SG50SA-PE04□□						
SG1ASA-PE04□□						
SG05SA-PE08□□	<10	540	428	0.0016	19.18	
SG10SA-PE08□□						
SG25SA-PE08□□		1035	900		0.0049	34.84
SG50SA-PE08□□						
SG05SA-PE15□□	<10	1035	900	0.0048	34.40	
SG10SA-PE15□□						
SG25SA-PE15□□		1687	1350		0.0047	60.75
SG50SA-PE15□□						

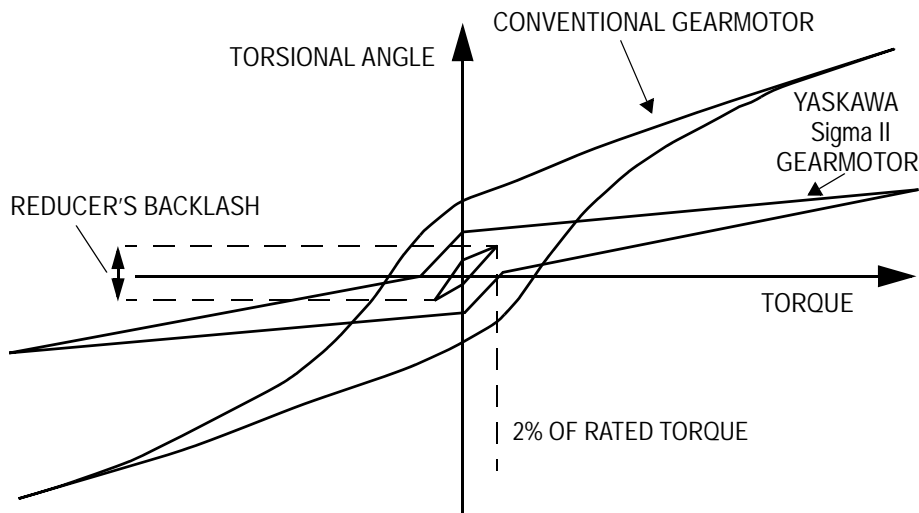

Dimensions in inches (mm)

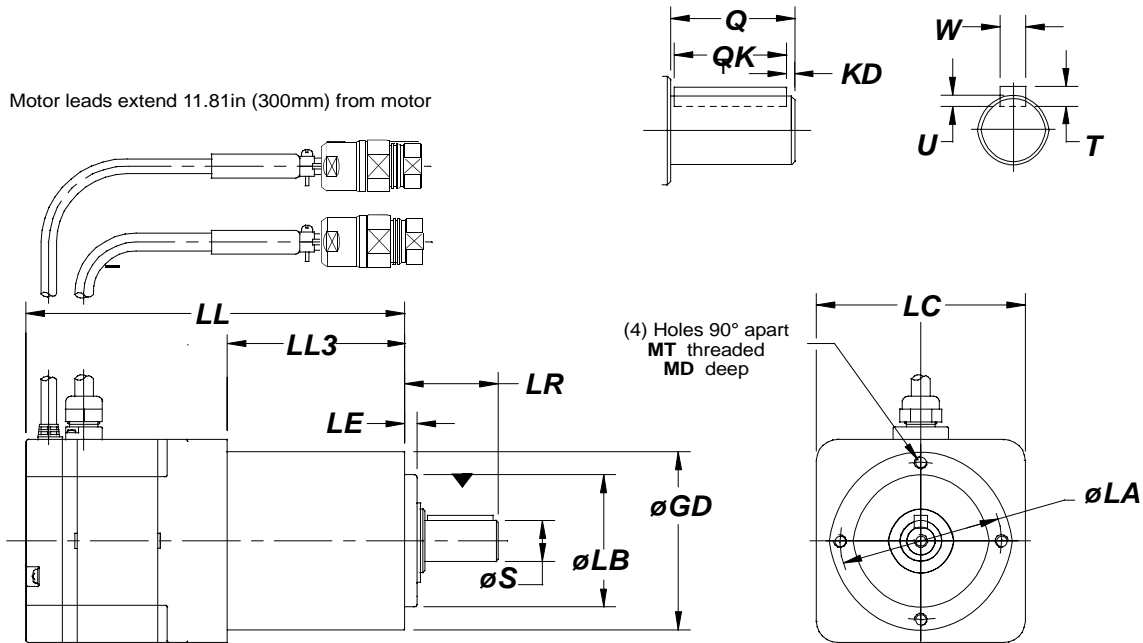

GEARMOTOR	LL3	LL	LE	LR	LB	GD	S	LC	LA	MT	MD	Q	QK	KD	W	T	U		
SG05SA-PE01□A	1.988 (50)	5.177 (131.5)	0.158 (4)	0.965 (24.5)	1.378 (35)	1.969 (50)	0.472 (12)	2.362 (60)	1.732 (44)	M4 x 0.7	0.315 (8)	0.709 (18)	0.551 (14)	0.079 (2)	0.158 (4)	0.158 (4)	0.098 (2.5)		
SG10SA-PE01□A																0.197 (5)	0.197 (5)	0.118 (3)	
SG25SA-PE01□A	3.465 (88)	6.858 (174.2)	0.197 (5)	1.417 (36)	2.047 (52)	2.756 (70)	0.630 (16)	2.756 (70)	2.441 (62)	M5 x 0.8	0.394 (10)	1.102 (28)	0.984 (25)			0.236 (6)	0.236 (6)	0.138 (3.5)	
SG50SA-PE01□A				1.811 (46)	2.677 (68)	3.543 (90)	0.866 (22)	3.543 (90)	3.150 (80)	M6 x 1.0	0.472 (12)	1.417 (36)	1.260 (32)						
SG1ASA-PE01□A	4.193 (106.5)	7.500 (190.5)		1.811 (46)	2.677 (68)	3.543 (90)	0.866 (22)	3.543 (90)	3.150 (80)	M6 x 1.0	0.472 (12)	1.417 (36)	1.260 (32)			0.236 (6)	0.236 (6)	0.138 (3.5)	
SG05SA-PE02□A	2.677 (68)	6.181 (157)		1.417 (36)	2.047 (52)	2.756 (70)	0.630 (16)	3.150 (80)	2.441 (62)	M5 x 0.8	0.394 (10)	1.102 (28)	0.984 (25)			0.197 (5)	0.197 (5)	0.118 (3)	
SG10SA-PE02□A				1.417 (36)	2.047 (52)	2.756 (70)	0.630 (16)	3.150 (80)	2.441 (62)	M5 x 0.8	0.394 (10)	1.102 (28)	0.984 (25)						
SG25SA-PE02□A	3.465 (88)	6.969 (177)		1.811 (46)	2.677 (68)	3.543 (90)	0.866 (22)	3.543 (90)	3.150 (80)	M6 x 1.0	0.472 (12)	1.417 (36)	1.260 (32)			0.236 (6)	0.236 (6)	0.138 (3.5)	
SG50SA-PE02□A	4.193 (106.5)	7.697 (195.5)		1.811 (46)	2.677 (68)	3.543 (90)	0.866 (22)	3.543 (90)	3.150 (80)	M6 x 1.0	0.472 (12)	1.417 (36)	1.260 (32)						
SG1ASA-PE02□A	5.295 (134.5)	9.036 (229.5)		0.236 (6)	2.756 (70)	3.543 (90)	4.724 (120)	1.260 (32)	4.724 (120)	4.252 (108)	M8 x 1.25	0.630 (16)	2.284 (58)		1.969 (50)	0.158 (4)	0.394 (10)	0.315 (8)	0.197 (5)
SG05SA-PE04□A	2.677 (68)	6.969 (177)		0.197 (5)	1.417 (36)	2.047 (52)	2.756 (70)	0.630 (16)	3.150 (80)	2.441 (62)	M5 x 0.8	0.394 (10)	1.102 (28)	0.984 (25)	0.079 (2)	0.197 (5)	0.197 (5)	0.118 (3)	
SG10SA-PE04□A					1.417 (36)	2.047 (52)	2.756 (70)	0.630 (16)	3.150 (80)	2.441 (62)	M5 x 0.8	0.394 (10)	1.102 (28)	0.984 (25)					
SG25SA-PE04□A	4.193 (106.5)	8.484 (215.5)	1.811 (46)		2.677 (68)	3.543 (90)	0.866 (22)	3.543 (90)	3.150 (80)	M6 x 1.0	0.472 (12)	1.417 (36)	1.260 (32)			0.236 (6)	0.236 (6)	0.138 (3.5)	
SG50SA-PE04□A	5.295 (134.5)	9.823 (249.5)	0.236 (6)		2.756 (70)	3.543 (90)	4.724 (120)	1.260 (32)	4.724 (120)	4.252 (108)	M8 x 1.25	0.630 (16)	2.284 (58)	1.969 (50)		0.158 (4)	0.394 (10)	0.315 (8)	0.197 (5)
SG1ASA-PE04□A	6.024 (153)	10.551 (268.0)	0.315 (8)	3.819 (97)	4.724 (120)	6.102 (155)	1.575 (40)	4.724 (120)	5.512 (140)	M10 x 1.5	0.787 (20)	3.228 (82)	2.756 (70)	0.236 (6)	0.472 (12)				
SG05SA-PE08□A	3.150 (80)	7.815 (198.5)	0.197 (5)	1.811 (46)	2.677 (68)	3.543 (90)	0.866 (22)	4.724 (120)	3.150 (80)	M6 x 1.0	0.472 (12)	1.417 (36)	1.260 (32)	0.079 (2)	0.236 (6)	0.236 (6)	0.138 (3.5)		
SG10SA-PE08□A			1.811 (46)	2.677 (68)	3.543 (90)	0.866 (22)	3.150 (80)		M6 x 1.0	0.472 (12)	1.417 (36)	1.260 (32)	0.079 (2)	0.236 (6)	0.236 (6)	0.138 (3.5)			
SG25SA-PE08□A	5.295 (134.5)	9.803 (249)	0.236 (6)	2.756 (70)	3.543 (90)	4.724 (120)	1.260 (32)		4.252 (108)	M8 x 1.25	0.630 (16)	2.284 (58)	1.969 (50)	0.158 (4)	0.394 (10)	0.315 (8)	0.197 (5)		
SG50SA-PE08□A	6.024 (153)	10.532 (267.5)	0.315 (8)	3.819 (97)	4.724 (120)	6.102 (155)	1.575 (40)		5.512 (140)	M10 x 1.5	0.787 (20)	3.228 (82)	2.756 (70)	0.236 (6)	0.472 (12)				
SG05SA-PE15□A	4.016 (102)	9.626 (244.5)	0.236 (6)	2.756 (70)	3.543 (90)	4.724 (120)	1.260 (32)		4.252 (108)	M8 x 1.25	0.630 (16)	2.284 (58)	1.969 (50)	0.158 (4)	0.394 (10)				
SG10SA-PE15□A			2.756 (70)	3.543 (90)	4.724 (120)	1.260 (32)	4.252 (108)		M8 x 1.25	0.630 (16)	2.284 (58)	1.969 (50)	0.158 (4)	0.394 (10)					
SG25SA-PE15□A	6.024 (153)	11.634 (295.5)	0.315 (8)	3.819 (97)	4.724 (120)	6.012 (155)	1.575 (40)		5.512 (140)	M10 x 1.5	0.787 (20)	3.228 (82)	2.756 (70)	0.236 (6)	0.472 (12)				
SG50SA-PE15□A			3.819 (97)	4.724 (120)	6.012 (155)	1.575 (40)	5.512 (140)		M10 x 1.5	0.787 (20)	3.228 (82)	2.756 (70)	0.236 (6)	0.472 (12)					

Tolerances for standard (SG) gearmotors

Dimension	ΦS		ΦLB		W	
Unit	Diameter	Tolerance	Diameter	Tolerance	Width	Tolerance
in	0.472, 0.630	+0.00047 +0.00004	1.378	+0.00000 -0.00063	0.158, 0.197, 0.236	+0.00000 -0.00118
	0.866	+0.00059 +0.00008	2.047, 2.677	+0.00000 -0.00075	0.39370	+0.00000 -0.00142
	1.25984, 1.57480	+0.00071 +0.00008	3.5433, 4.724	+0.00000 -0.00087	0.47244	+0.00000 -0.00169
mm	12, 26	+0.012 +0.001	35	+0.000 -0.016	4, 5, 6	+0.000 -0.030
	22	+0.015 +0.002	52, 68	+0.000 -0.019	10	+0.000 -0.036
	32, 40	+0.018 +0.002	90, 120	+0.000 -0.022	12	+0.000 -0.043

Selecting Your SGMPH Gearmotor System

First, select the Sigma II servomotor suited for your application using SigmaSize: the Yaskawa servomotor sizing software, available at no charge. (Request SigmaSize software via e-mail, at: literature@yaskawa.com).

Use the diagram below to locate and identify the components of your system. Each item is letter-coded and cross-referenced in the option tables on the following pages.

System Configuration

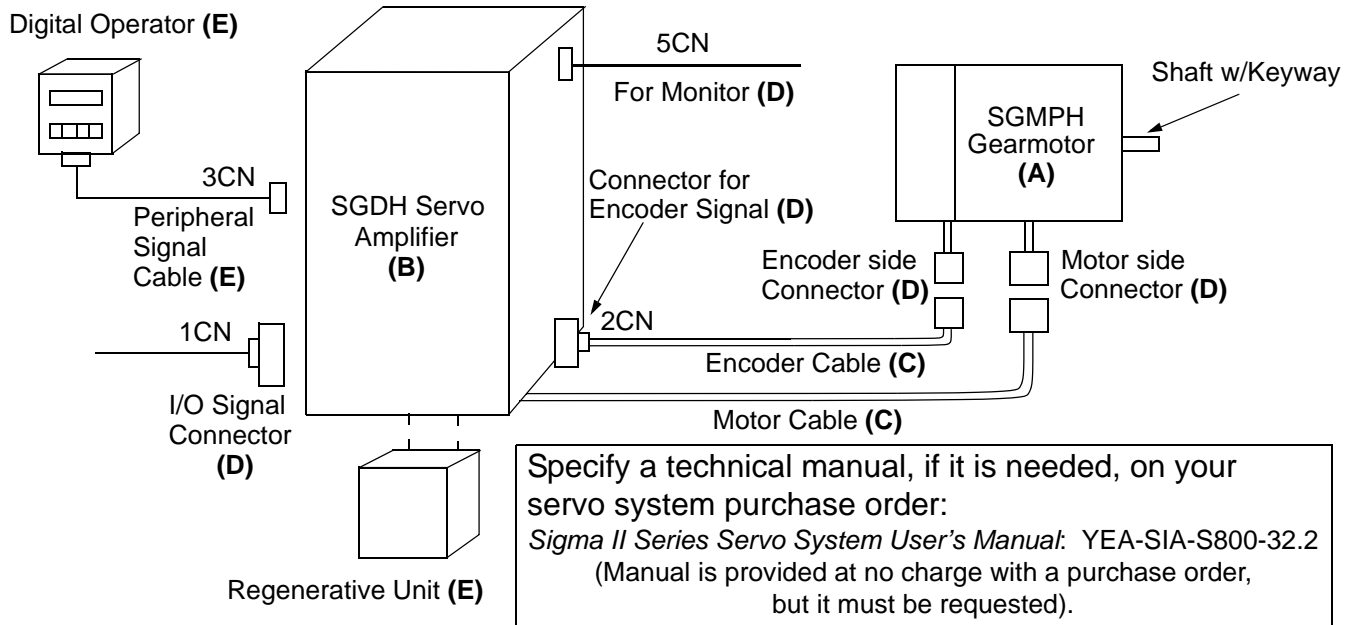

Model Number Designation

SG 05 S A-PE 02 A A [C]

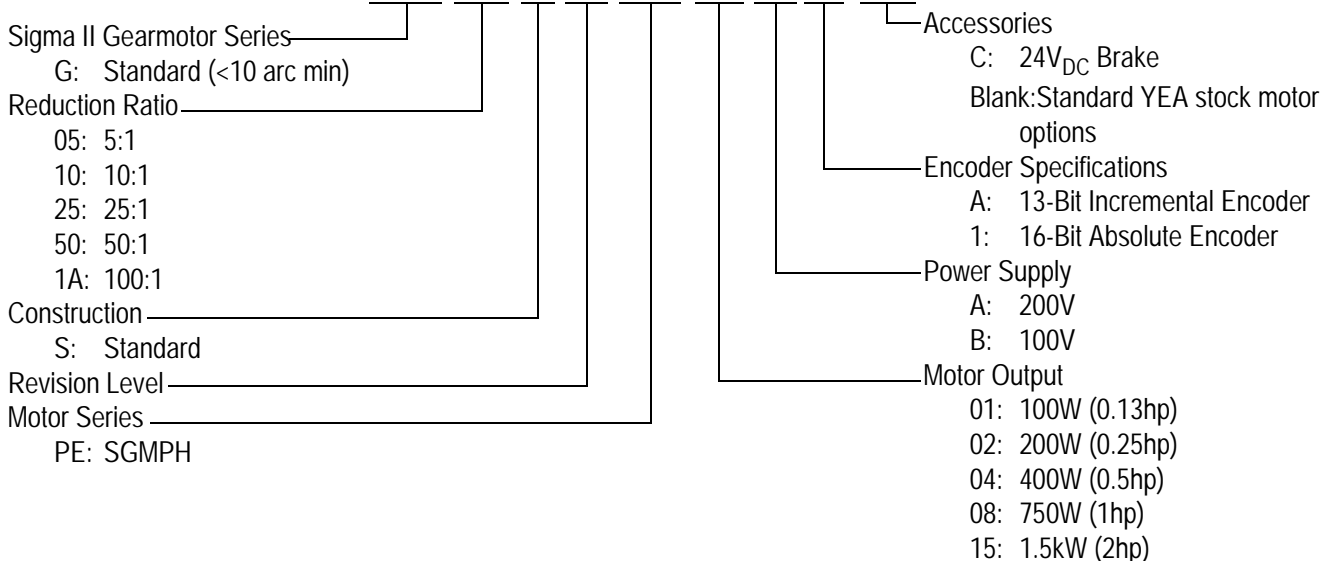

Gearmotor & Amplifier Selection

Use the table below to select the appropriate SGMPH Sigma II gearmotor and amplifier.

(Refer to the motor model # designation on the previous page specifying the available modification to motor construction/features.)

Gearmotor (A)					Gearhead only		Amplifier MODEL # (B)* SGDH-	Gear Motor Item Class	Amplifier Item Class	
MODEL #	Rated Torque (in • lb)	Peak Torque (in • lb)	Rated Speed (rpm)	Maximum Speed (rpm)	Inertia (in • lb • s ²)	Gear Ratio				
SG05SA-PE01AA	13.67	40.93	600	1000	0.000052	5:1	01A□	Normal leadtime 3 - 4 weeks for assembly	Stock	
SG10SA-PE01AA	27.34	81.84	300	500		10:1				
SG25SA-PE01AA	66.95	200.39	120	200	0.00025	25:1				
SG50SA-PE01AA	133.89	283.00	60	100		50:1				
SG1ASA-PE01AA	267.78	637.00	30	50	0.0016	100:1				
SG05SA-PE02AA	27.34	81.84	600	1000	0.00025	5:1				02A□
SG10SA-PE02AA	54.68	163.69	300	500		10:1				
SG25SA-PE02AA	133.89	283.00	120	200		25:1				
SG50SA-PE02AA	267.78	708.00	60	100		0.0016				
SG1ASA-PE02AA	535.56	1593.00	26	48	0.0049	100:1				
SG05SA-PE04AA	54.81	164.42	600	1000	0.00025	5:1				04A□
SG10SA-PE04AA	109.61	283.00	300	500		10:1				
SG25SA-PE04AA	268.38	708.00	120	200	0.0016	25:1				
SG50SA-PE04AA	536.75	1610.25	52	96		50:1				
SG1ASA-PE04AA	1073.50	2832.00	20	36	0.0047	100:1				
SG05SA-PE08AA	102.34	306.04	600	1000	0.0016	5:1				08A□
SG10SA-PE08AA	204.67	612.07	300	500		10:1				
SG25SA-PE08AA	501.13	1498.63	104	192	0.0049	25:1				
SG50SA-PE08AA	1002.25	2997.25	40	72	0.0047	50:1				
SG05SA-PE15AA	205.16	614.50	520	960	0.0048	5:1	15A□			
SG10SA-PE15AA	410.31	1228.99	260	480		10:1				
SG25SA-PE15AA	1004.63	3009.13	80	144	0.0047	25:1				
SG50SA-PE15AA	2009.25	3540.00	40	72	0.0047	50:1				
SG05SA-PE01BA	13.67	40.93	600	1000	0.000052	5:1	01B□			
SG10SA-PE01BA	27.34	81.84	300	500		10:1				
SG25SA-PE01BA	66.95	200.39	120	200	0.00025	25:1				
SG50SA-PE01BA	133.89	283.00	60	100		50:1				
SG1ASA-PE01BA	267.78	637.00	30	50	0.0016	100:1				
SG05SA-PE02BA	27.34	81.84	600	1000	0.00025	5:1	02B□			
SG10SA-PE02BA	54.68	163.69	300	500		10:1				
SG25SA-PE02BA	133.89	283.00	120	200		25:1				
SG50SA-PE02BA	267.78	708.00	60	100		0.0016		50:1		
SG1ASA-PE02BA	535.56	1593.00	26	48	0.0049	100:1				

SGMPH Gearmotors

Notes: 24V_{DC} Brakes for SGMPH Sigma II gearmotors are standard. Contact a local source for 24V_{DC} power supplies.

Use the tables on the following page to specify mating connectors or pre-wired cables in different lengths.

For technical information, request Yaskawa technical bulletin number YEA-TSA-S800-16.16 and Yaskawa manual number TSE-S800-15.

100/200V Single-phase Sigma II Servo Systems

* For more detailed 100/200V SGDh amplifier specifications and dimensions, refer to pages 99 - 112.

Pre-wired Cable Selection

Use the table below to select pre-wired cables for your SGMPH Sigma II gearmotor.

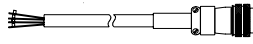
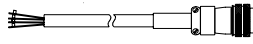
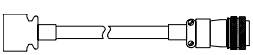
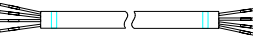
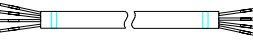
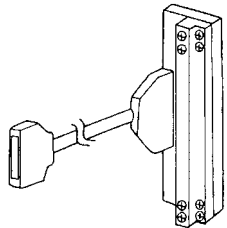
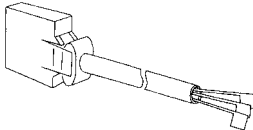
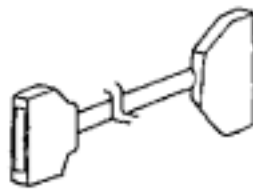
Cable Description (C)		Motor Size (kW)	Part Number*	Comments	Item Class	
Power Cable with Interconnectron Connectors (without Brake)		0.1, 0.2, 0.4, 0.8	B4ICE-□□(A)	These UL and CE compliant cables are available in five lengths. Use the following key to specify needed cable length (last two digits of the part number): 03: 3m 05: 5m 10: 10m (standard) 15: 15m 20: 20m	Stock**	
		1.5	B5ICE-□□(A)			
Power Cable with Interconnectron Connectors (with Brake)		0.1, 0.2, 0.4, 0.8	B4IBCE-□□(A)			
		1.5	B5IBCE-□□(A)			
Encoder Cable with Interconnectron Connector (incremental or absolute)		All	A1ICE-□□(A)			
Encoder Cable (for applications up to 20m) Only for Solder Connections			FR-RMCT-SB			These cables are available in any length.
Encoder Cable (for applications from >20 to <50m) Only for Solder Connections			UL20276-SB			For example, to order one FR-RMCT-SB cable, 16m long, specify: quantity: 16 part no.: FR-RMCT-SB
Input/Output 1CN Cable & Transition Terminal Block			JUSP-TA50P			35mm DIN rail mountable; the cable length is 0.5 meters.
Input/Output 1CN Cable with Pigtail Leads			JZSP-CKI01-□(A)	Use the following key to specify required cable length (last digit of part number): 1: 1m (standard) 2: 2m 3: 3m		
Input/Output 1CN Cable Cable with Female D-Sub output Connector***			JZSP-CKI0D-□□	Use the following key to specify required cable length (last two digits of the part number): D50: 0.5m 01: 1m (standard) 02: 2m 03: 3m		

* The "(A)" at the end of the cable part number indicates the revision level. Revision level may be subject to change prior to this catalog reprinting.

** Standard cable lengths are Stock items; non-standard cable lengths are Limited Stock items.

*** 50 Pin Female D-Sub output connector mates to customer supplied third party terminal block. (e.g., Wago #289-449, Weidmuller #919658, Phoenix #2283647, Amphenol/Sine #20-51039, and many others)

Connector Selection

Use the table below to select mating connectors or kits for your SGMPH Sigma II gearmotor.

Connector Description (D)	Motor Size (kW)	Part Number	Comments	Item Class
Interconnectron Connector for Motor Power Cable (with or without Brake)	0.1, 0.2, 0.4, 0.8, 1.5	FIN07S-B2	IP67 Mated Solder Cup	Stock
2CN Amplifier Mating Connector		JZSP-CMP9-1	—	
Interconnectron Connector for Encoder Cable (incremental or absolute encoder)		FIN17C-A2	IP67 Mated Gauge: 24 - 18 AWG Requires Crimp Tool B150 and positioner.	
1CN Mating Connector	All	JZSP-CKI9	—	
Interconnectron Crimp Tool		B150	—	
Positioner		B055/A	—	

100/200V Single-phase Sigma II Servo Systems

Peripheral Device Selection

Use the table below to select peripheral devices for your SGMPH Sigma II gearmotor.

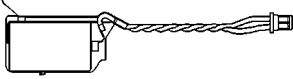
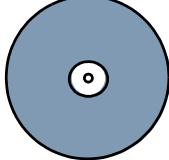
Component Description (E)	Part Number	Comments	Item Class	
Hand-held Digital Operator Panel 	JUSP-OP02A-1 and JZSP-CMS00-1	Portable unit with 1m adapter cable for Sigma II	Stock	
Absolute Encoder Battery 	JZSP-BA01	3.6V, 1000mAh (lithium battery)		
Software Interface Cable —	YS-12	Pre-wired 2.0m cable with 9-pin connector		
SigmaWin+ Software 	JZSP-WP0001	Minimum Recommended System Requirements Pentium 200 MHz, 64MB RAM, 200MB hard drive, CDROM Drive, RS-232 or RS-422 port, Screen resolution 800x600 w/ 256 colors, and Windows 95,98,NT4.0,2000,ME. (Windows XP planned)		
Individual External Regenerative Unit	For: SGDH-01AE SGDH-02AE SGDH-04AE SGDH-08AE SGDF-08AE-S amps	RH12050ohmJ		These are general purpose regenerative units.* Caution: Proper set-up is necessary to avoid equipment damage.
	For: SGDH-15AE SGDH-15AE-S	RH500N25_ohmK		
DC Reactor (for suppressing harmonics in the power supply)	For 200V: SGDH-01AE SGDH-02AE SGDH-04AE SGDH-08AE SGDF-08AE-S SGDH-15AE SGDH-15AE-S	X5071 X5070 X5069 X5061 X5079 X5060 X5078	— —	Limited Stock
	For 100V: SGDH-01BE SGDH-02BE	X5063 X5062		

* For an alternate solution, specify the individual resistor part number RH500N25_OHMK in necessary series or parallel connection. Refer to the SGDH servo amplifier section of this catalog (pages 97 to 126) for additional specifications, and the *Sigma II Series Servo System User's Manual* (YEA-SIA-S800-32.2) for proper resistor sizing guidelines.

General Purpose SGMGH Servomotors - With Incremental / Absolute Encoder

Rated Output: 0.45kW, 0.85kW,
1.3kW, 1.8kW, 2.9kW,
4.4kW, 5.5kW, 7.5kW,
11kW, 15kW.

SGMGH
Servomotors



For Additional Information	Page(s)
SGMGH Ratings & Specifications	58
SGMGH Speed/Torque Curves	59
SGMGH Dimensions	60 - 62
SGMGH Selection/Ordering Information	63 - 68
SGDH Ratings & Specifications	99 - 100
SGDH Dimensions	101 - 112

Design Features

1. Compact

- Small sized motor
 - Compatible with previous generation G series motors
 - Ten types of rated outputs ranging from 0.79 to 1988in • lb of peak torque
 - Optional built-in holding brake available

2. Higher Speed and acceleration

- Up to 3000rpm maximum
- High torque to inertia ratio

3. Encoders

- 17-bit (32,768 ppr x 4) incremental encoder (standard)
- 17-bit absolute encoder (optional)

4. Enhanced Environmental Resistance

- Totally enclosed, self-cooled IP67 (excluding shaft)
- Shaft seal (optional)

5. Application Emphasis

- Machine tools and woodworking machines
- Packaging machines
- Gantry Robots
- Press Automation
- Thermoforming

6. Certified International Standards

- UL, cUL recognized (File #: E165827) CE compliance

Servomotor Ratings and Specifications

Time Rating:	Continuous	Enclosure:	Totally-enclosed, self-cooled	Maximum Rotational Speed*:	
Insulation:	Class F		IP67 (except for shaft opening)	0.45 to 7.5kW: 3000rpm	
Vibration:	15µm or less	Ambient Temperature:	0 to 40°C	11 and 15kW: 2000rpm	
Withstand Voltage:	1500V _{ac}	Ambient Humidity:	20 to 80%	Excitation:	Permanent magnet
Insulation Resistance:	10MΩ minimum at 500V _{DC}		(non-condensing)	Drive Method:	Direct drive
		Rated Speed*:	1500rpm	Mounting:	Flange-mounted

* Values when the servomotor is combined with an SGD servo amplifier.

MOTORS: SGMGH-	Rated Output*	Rated Torque*		Instantaneous Peak Torque*		Rated Current*	Instantaneous Maximum Current*
	kW (hp)	N · m	lb _f · in (KG · cm)	N · m	lb _f · in (KG · cm)	A _{rms}	A _{rms}
05A□A	0.45 (0.6)	2.84	25 (29)	8.92	79 (91)	3.8	11
09A□A	0.85 (1.1)	5.39	48 (55)	13.8	122 (141)	7.1	17
13A□A	1.3 (1.7)	8.34	74 (85)	23.3	207 (238)	10.7	28
20A□A	1.8 (2.4)	11.5	102 (117)	28.7	254 (293)	16.7	42
30A□A	2.9 (3.9)	18.6	165 (190)	45.1	400 (460)	23.8	56
44A□A	4.4 (5.9)	28.4	252 (290)	71.1	629 (725)	32.8	84
55A□A	5.5 (7.4)	35.0	310 (357)	87.6	775 (894)	42.1	110
75A□A	7.5 (10)	48.0	425 (490)	119	1053 (1210)	54.7	130
1AA□A	11 (15)	70.0	620 (714)	175	1550(1790)	58.6	140
1EA□A	15 (20)	95.4	845 (974)	224	1988(2290)	78.0	170

* Values when the servomotor is combined with an SGD servo amplifier.

MOTORS SGMGH-	Torque Constant $\frac{lb_f \cdot in}{A_{rms}} \left(\frac{N \cdot m}{A_{rms}} \right)$	Moment of Inertia lb · in · s ² × 10 ⁻³ KG · m ² × 10 ⁻⁴		Holding Brake (at 20°C)					Allowable Load Inertia KG · m ² × 10 ⁻⁴	Rated Power Rate* kW/s	Rated Angular Acceleration* rad/s ²	Inertia Time Constant ms	Inductive Time Constant ms
				Capacity	Torque	Coil. Resistance	Rated Current	Additional Inertia					
				W	N · m	W	A	lb · in · s ² × 10 ⁻³					
05A□A	7.3 (0.82)	6.41	7.24	9.85	4.41	58.5	0.41	1.85	36.2	11.2	3930	5.0	5.1
09A□A	7.3 (0.83)	12.3	13.9		12.7				69.5	20.9	3880	3.1	5.3
13A□A	7.4 (0.84)	18.2	20.5		103				33.8	4060	2.8	6.3	
20A□A	6.5 (0.73)	28.1	31.7	18.5	43.1	31.1	0.77	7.75	159	41.5	3620	2.2	12.8
30A□A	7.3 (0.82)	40.7	46.0						230	75.3	4050	1.9	12.5
44A□A	8.0 (0.91)	59.8	67.5						338	120	4210	1.3	15.7
55A□A	7.8 (0.88)	78.8	89.0	23.5	72.6	24.5	0.98	7.75	445	137	3930	1.3	16.4
75A□A	8.2 (0.93)	111	125						625	184	3850	1.1	18.4
1AA□A	11 (1.25)	249	281	32.0	84.3	18.0	1.33	16.7	1405	174	2490	1.2	22.6
1EA□A	11.7 (1.32)	279	315	35.0	115	16.4	1.46	33.2	1575	289	3030	0.98	27.2

* Values when the servomotor is combined with an SGD servo amplifier at an armature winding temperature of 20°C.

** These characteristics can be obtained when the following heat sinks (steel plates) are used for cooling purposes:

Type 05A□A to 13A□A:	15.75 × 15.75 × 0.79 (in)	(400 × 400 × 20 (mm))
Type 20A□A to 75A□A:	21.65 × 21.65 × 1.18 (in)	(550 × 550 × 30 (mm))
Type 1AA□A to 1EA□A:	25.59 × 25.59 × 1.38 (in)	(650 × 650 × 35 (mm))

Speed / Torque Curves

200V

SGMGH
Servomotors

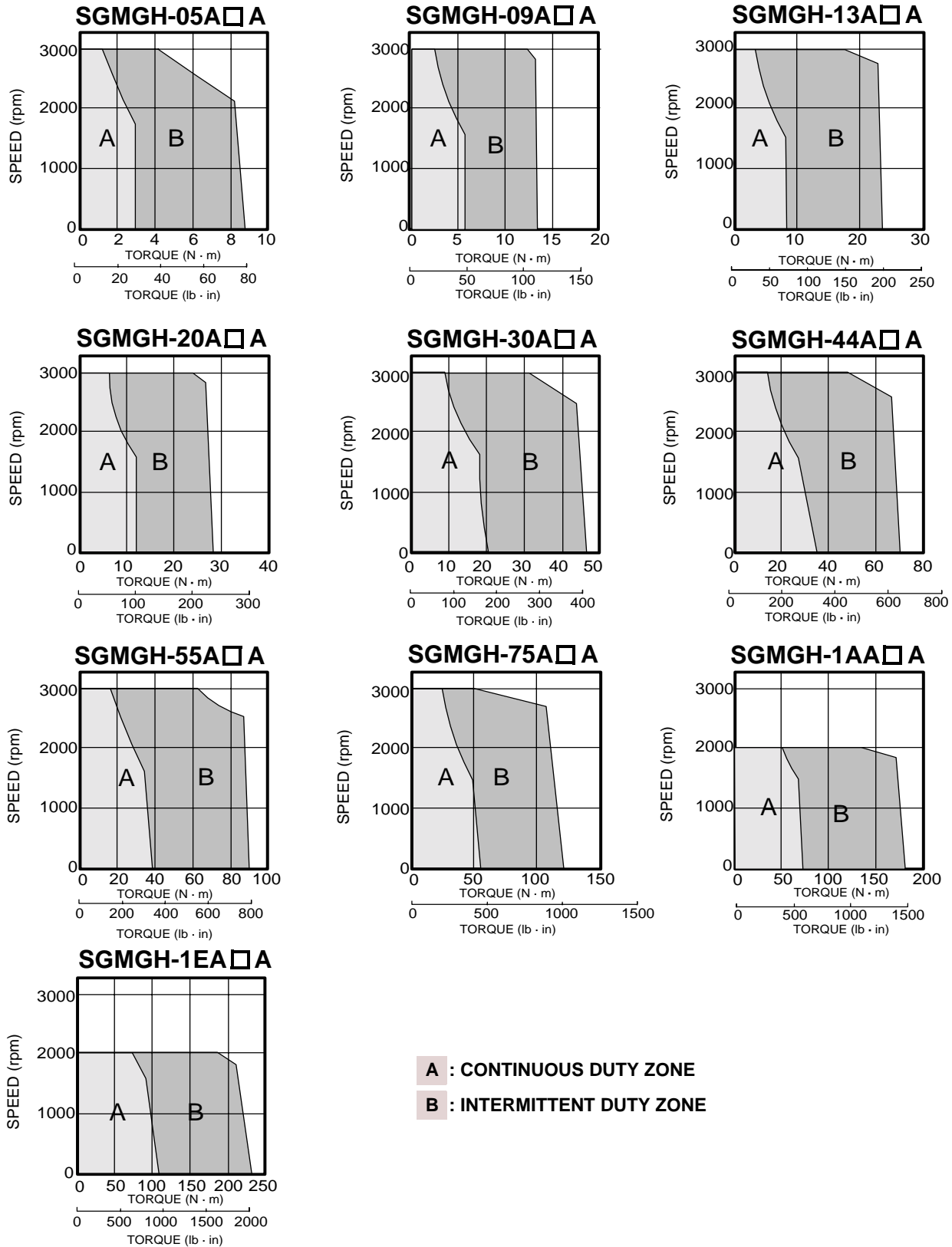

200V Three-phase Sigma II Servo Systems

Dimensions in inches (mm)

(1) 17-Bit Incremental/Absolute Encoder

SGMGH Servomotors

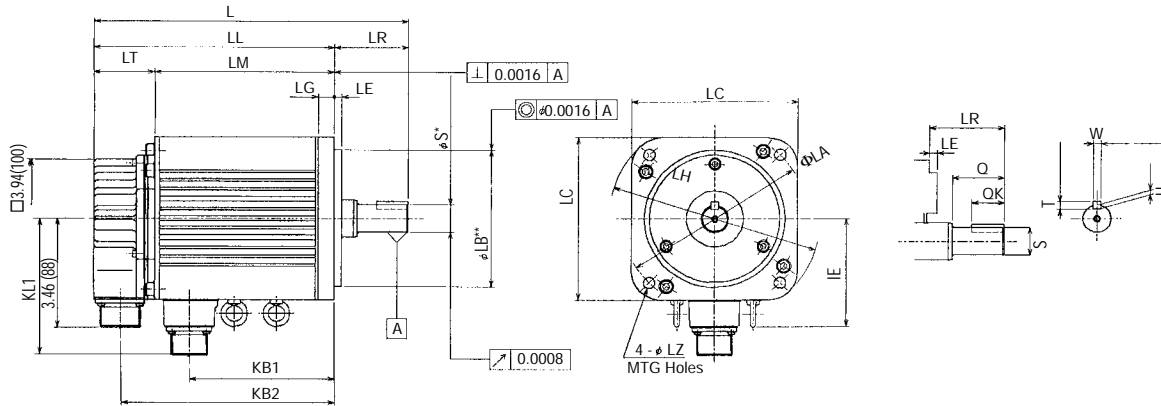

Type SGMGH-	L	LL	LM	LR	LT	KB1	KB2	IE	KL1	Flange Dimensions						Shaft End Dimension					Approximate Mass lb _r (kg)	Allowable Radial Load lb _r (N)	Allowable Thrust Load lb _r (N)			
										FLA	FLB**	LC	LE	LG	FLH	FLZ	FS*	Q	QK	W				T	U	
05A□A61	7.72 (196)	5.43 (138)	3.62 (92)			2.56 (65)	4.61 (117)											0.75 (19)	1.57 (40)	0.98 (25)	0.20 (5)	0.20 (5)	0.12 (3)	12.1 (5.5)	110 (490)	22 (98)
09A□A61	8.62 (219)	6.34 (161)	4.53 (115)	2.28 (58)	1.81 (46)	3.46 (88)	5.51 (140)		4.29 (109)	5.71 (145)	4.33 (110)	5.12 (130)	0.24 (6)	0.47 (12)	6.5 (165)	0.35 (9)								16.8 (7.6)		
13A□A61	9.57 (243)	7.28 (185)	5.47 (139)			4.41 (112)	6.46 (164)											0.87 (22)			0.24 (6)	0.24 (6)	0.14 (3.5)	21.2 (9.6)	154 (686)	77 (343)
20A□A61	9.65 (245)	6.54 (166)	4.69 (119)			3.5 (89)	5.71 (145)																	30.9 (14)	265 (1176)	
30A□A61	10.67 (271)	7.56 (192)	5.71 (145)	3.11 (79)	1.85 (47)	4.53 (115)	6.73 (171)		5.51 (140)									1.38 (35)	2.99 (76)	2.36 (60)	0.39 (10)			39.7 (18)	331 (1470)	110 (490)
44A□A61	12.01 (305)	8.9 (226)	7.05 (179)			5.87 (149)	8.07 (205)			7.87 (200)	4.5 (114.3)	7.09 (180)	0.13 (3.2)	0.71 (18)	9.06 (230)	0.53 (13.5)						0.31 (8)	0.20 (5)	50.7 (23)		
55A□A61	14.69 (373)	10.24 (260)	8.39 (213)	4.45 (113)		6.85 (174)	9.41 (239)	4.92 (125)	5.91 (150)															66.1 (30)		
75A□A61	17.6 (447)	13.15 (334)	11.3 (287)		1.85 (47)	9.76 (248)	12.32 (313)											1.65 (42)	4.33 (110)	3.54 (90)	0.47 (12)			88.2 (40)	397 (1764)	132 (588)
1AA□A61	17.87 (454)	13.31 (338)	11.46 (291)	4.57 (116)		9.88 (251)	12.48 (317)	5.59 (142)	6.61 (168)	9.25 (235)	7.87 (200)	8.66 (220)	0.16 (4)	0.79 (20)	10.63 (270)									127 (57.5)		
1EA□A61	22.56 (573)	17.99 (457)	15.28 (388)		2.72 (69)	13.50 (343)	17.13 (435)											2.17 (55)			0.63 (16)	0.39 (10)	0.24 (6)	189.6 (86)	1125 (4998)	485 (2156)

- Note: 1. SGMGH-05A□A to 44A□A do not contain eyebolts.
 2. Dimensions are the same when using either incremental or absolute encoders (with or without optional shaft seal).
 3. Tolerances on the dimensions of flange type LB and of shaft extensions S are based on JIS (Japanese Industrial Standard) B0401 "Limits and Fits for Engineering."

Specified Tolerances					
Dimension	*ΦS		**ΦLB		
	Unit	Diameter	Tolerance	Diameter	Tolerance
in		0.7480	0.8661	4.3307	+0.0000 -0.0014
		1.3780	+0.0004 -0.0000	4.5000	+0.0000 -0.0010
		1.6535	+0.0000 -0.0006		
		2.1700	+0.0012 +0.0004	7.8700	+0.0000 -0.0018
mm		19.000	22.000	110.000	+0.0000 -0.035
		35.000	+0.010 -0.000	114.300	+0.0000 -0.025
		42.000	+0.000 -0.016	200.000	+0.0000 -0.046
		55.000	+0.030 +0.011		

Encoder Plug

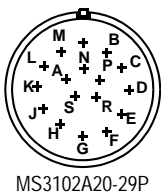

MS3102A20-29P

Connector Wiring on the Encoders			
A	—	K	—
B	—	L	—
C	Data +	M	—
D	Data -	N	—
E	—	P	—
F	—	R	—
G	0V	S	Battery - (Note*)
H	+5V _{dc}	T	Battery + (Note*)
J	FG (Frame Ground)		

*Note: Used with an absolute encoder only.
 Non-Environmental Mating Connector:
 MS3108B20-29S (L Type)
 MS3106B20-29S (Straight Type)

Motor Plug

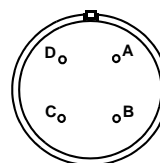

Connector Wiring on the Motor Side	
A	U Phase
B	V Phase
C	W Phase
D	Ground Terminal

(2) 17-Bit Incremental/Absolute Encoder. with Brake

- 0.5 to 4.4kW (0.7 to 5.9hp)

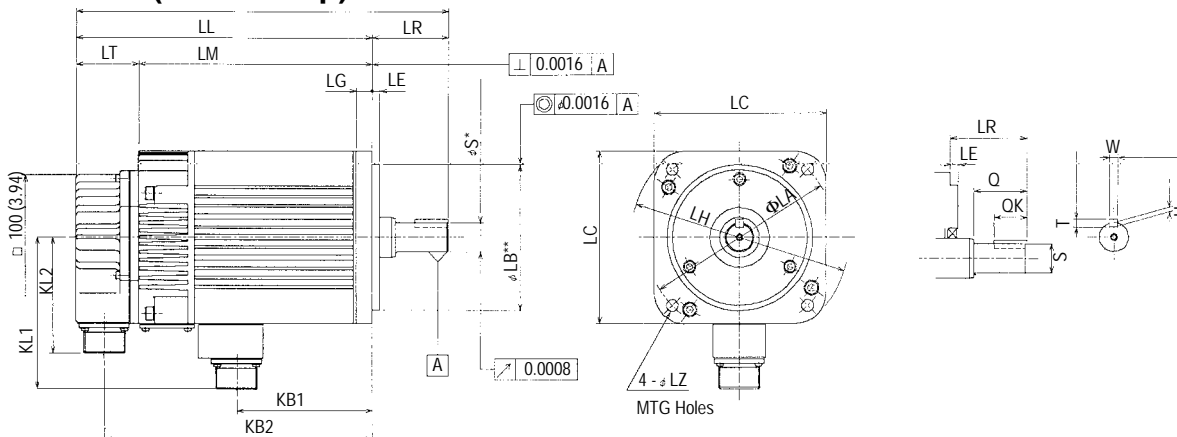

Type SGMGH-	L	LL	LM	LR	LT	KB1	KB2	KL1	KL2	Flange Dimensions				Shaft End Dimension					Approximate Mass lb _f (kg)	Allowable Radial Load lb _f (N)	Allowable Thrust Load lb _f (N)					
										ΦLA	ΦLB**	LC	LE	LG	ΦLH	ΦLZ	ΦS*	Q				QK	W	T	U	
05A□A6C	9.21 (234)	6.93 (176)	5.08 (129)			2.2 (56)	6.1 (155)									0.75 (19)			0.20 (5)	0.20 (5)	0.12 (3)	16.5 (7.5)	110 (490)	22 (98)		
09A□A6C	10.1 2 (257)	7.83 (199)	5.98 (152)	2.28 (58)		3.11 (79)	7.01 (178)	4.72 (120)		5.71 (145)	4.33 (110)	5.12 (130)	0.24 (6)	0.47 (12)	6.5 (165)	0.35 (9)	1.57 (40)	0.98 (25)				21.2 (9.6)				
13A□A6C	11.0 6 (281)	8.78 (223)	6.93 (176)		1.85 (47)	4.06 (103)	7.95 (202)									0.87 (22)			0.24 (6)	0.24 (6)	0.14 (3.5)	26.5 (12)	154 (686)	77 (343)		
20A□A6C	11.6 5 (296)	8.54 (217)	6.69 (170)			3.11 (79)	7.72 (196)		3.46 (88)													41.9 (19)	331 (1470)	110 (490)		
30A□A6C	12.6 8 (322)	9.57 (243)	7.72 (196)	3.11 (79)		4.13 (105)	8.74 (222)	5.75 (146)		7.87 (200)	4.5 (114.3)	7.09 (180)	0.13 (3.2)	0.71 (18)	9.06 (230)	0.53 (13.5)	1.38 (35)	2.99 (76)	2.36 (60)	0.39 (10)	0.31 (8)	51.8 (23.5)				
44A□A6C	14.0 2 (356)	10.9 1 (277)	9.06 (230)			5.47 (139)	10.0 8 (256)															62.8 (28.5)				

Note: 1. Dimensions are the same when using either incremental or absolute encoders (with or without optional shaft seal).
 2. Tolerances on the dimensions of flange type LB and of shaft extensions S are based on JIS (Japanese Industrial Standard) B0401 "Limits and Fits for Engineering."

Specified Tolerances					
Dimension	*ΦS		**ΦLB		
	Unit	Diameter	Tolerance	Diameter	Tolerance
in		0.7480, 0.8661	+0.0000-0.0005	4.3307	+0.0000 -0.0014
		1.3780	+0.0004-0.0000	4.5000	+0.0000 -0.0010
mm		19.000, 22.000	+0.000 -0.013	110.000	+0.000 -0.035
		35.000	+0.010 -0.000	114.300	+0.000 -0.025

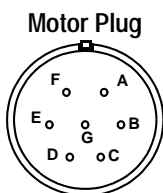

Connector Wiring on the Motor Side			
A	U Phase	E	Brake Terminal
B	V Phase	F	Brake Terminal
C	W Phase	G	—
D	FG (Frame Ground)		

200V Three-phase Sigma II Servo Systems

- 5.5 to 15kW (7.4 to 20hp)

SGMGH Servomotors

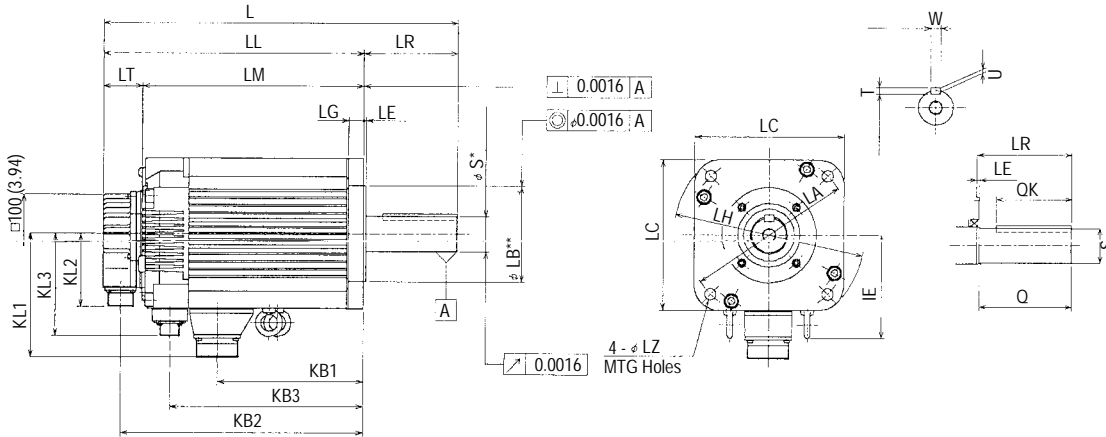

Type SGMGH-	L	LL	LM	LR	LT	KB1	KB2	KB3	IE	KL1	KL2	KL3	Flange Dimensions						Shaft End Dimension					Approximate Mass lb _r (kg)	Allowable Radial Load lb _r (N)	Allowable Thrust Load lb _r (N)				
													ΦLA	ΦLB**	LC	LE	LG	ΦLH	ΦLZ	ΦS*	Q	OK	W				T	U		
55A□A6C	16.69 (424)	12.24 (311)	10.39 (264)	4.45 (113)	1.85 (47)	6.85 (174)	11.42 (290)	9.09 (231)	4.92 (125)	5.91 (150)	3.46 (88)	4.84 (123)	7.87 (200)	4.5 (114.3)	7.09 (180)	0.13 (3.2)	0.71 (18)	9.06 (230)	0.53 (13.5)	1.65 (42)	4.33 (110)	3.54 (90)	0.47 (12)	0.31 (8)	0.20 (5)	77.2 (35)	397 (1764)	132 (588)		
75A□A6C	19.61 (498)	15.16 (385)	13.31 (338)	4.57 (116)	1.69 (43)	10.16 (258)	14.25 (362)	12.40 (315)	5.59 (142)	6.61 (168)		5.59 (142)	9.25 (235)	7.87 (200)	8.66 (220)	0.16 (4)	0.79 (20)	10.63 (270)		1.65 (42)						100.3 (45.5)				
1AA□A6C	19.65 (499)	15.08 (383)	13.39 (340)		1.81 (46)	13.50 (343)	19.57 (497)	16.34 (415)				5.59 (142)	6.61 (168)	5.59 (142)	9.25 (235)	7.87 (200)	8.66 (220)	0.16 (4)		0.79 (20)						10.63 (270)			1.65 (42)	145 (65.5)
1EA□A6C	25.00 (635)	20.43 (519)	18.62 (473)		1.81 (46)	13.50 (343)	19.57 (497)	16.34 (415)				5.59 (142)	6.61 (168)	5.59 (142)	9.25 (235)	7.87 (200)	8.66 (220)	0.16 (4)		0.79 (20)						10.63 (270)			2.17 (55)	189.6 (86)

Note: 1. Dimensions are the same when using either incremental or absolute encoders (with or without optional shaft seal).
2. Tolerances on the dimensions of flange type LB and of shaft extensions S are based on JIS (Japanese Industrial Standard) B0401 "Limits and Fits for Engineering."

Specified Tolerances					
Dimension	*FS		**FLB		
	Unit	Diameter	Tolerance	Diameter	Tolerance
in		1.6535	+0.0000-0.0006	4.5000	+0.0000 -0.0010
		2.1700	+0.0012+0.0004	7.8700	+0.0000 -0.0018
mm		42.000	+0.000 -0.016	114.300	+0.000 -0.025
		55.000	+0.030 +0.011	200.000	+0.0000 -0.046

Plug for Holding Brake

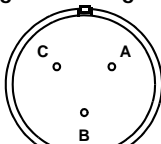

MS3102A1056-3P

Connector Wiring on the Brake, Motor Side

A	Brake Terminal
B	Brake Terminal
C	—

Non-Environmental Mating Connector:
MS3108A1056-3S (L Type)
MS3106A1056-3S (Straight Type)
Cable Clamp: MS3057-4A

Motor Plug

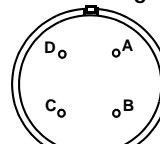

Connector Wiring on the Power, Motor Side

A	U Phase
B	V Phase
C	W Phase
D	Ground Terminal

Selecting Your SGMGH Sigma II Servo System

First, select the Sigma II servomotor suited for your application using SigmaSize: the Yaskawa servomotor sizing software, available at no charge. (Request SigmaSize software via e-mail, at: literature@yaskawa.com).

Use the diagram below to locate and identify the components of your system. Each item is letter-coded and cross-referenced in the option tables on the following pages.

System Configuration

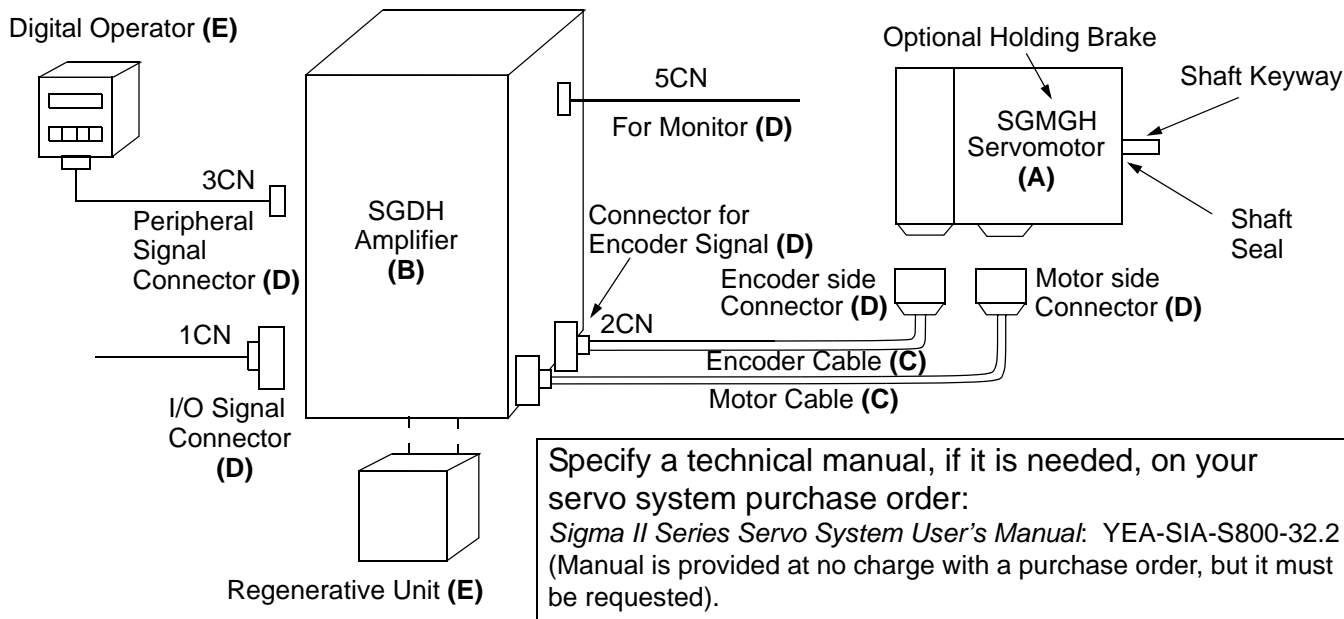

Model Number Designation

SGMGH - 09 A C A 6 [C]

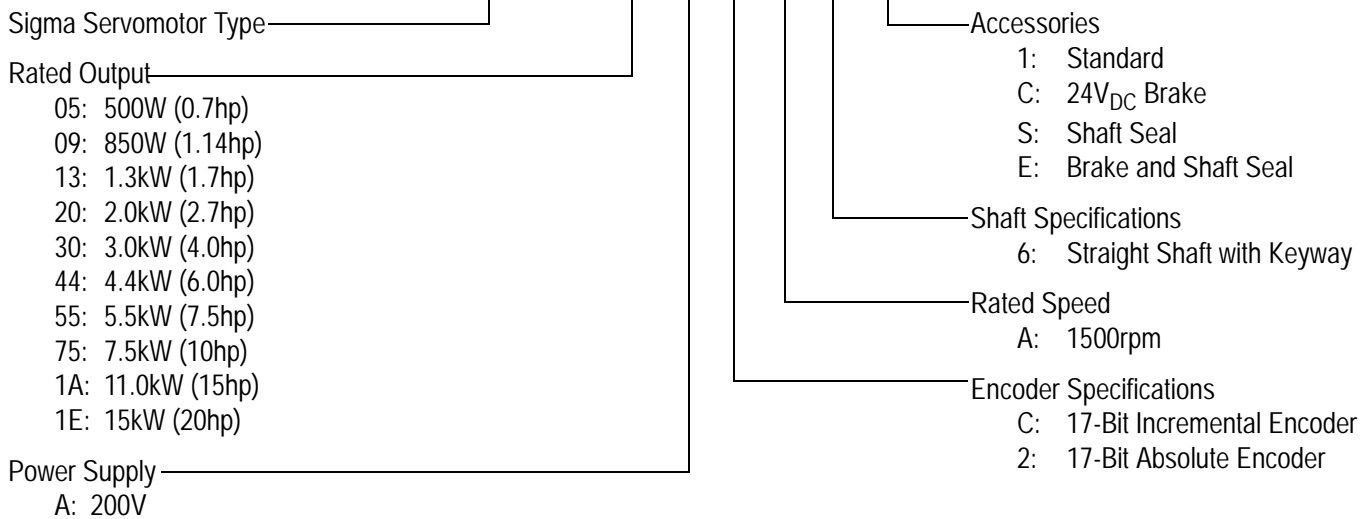

200V Three-phase Sigma II Servo Systems

Servomotor & Amplifier Selection

Use the table below to select the appropriate SGMGH Sigma II servomotor and amplifier.
(Refer to the motor model # designation on the previous page specifying the available modification to motor construction/features.)

SGMGH
Servomotors

Description	Peak Torque (in • lb)	Rated Torque (in • lb)	Motor Inertia (in • lb • s ² x 10 ⁻³)	Motor MODEL # (A)	Amplifier MODEL # (B)* Analog/Digital Input SGDH-	Motor & Amplifier Item Class	
200V Three-Phase 17-bit Incremental Encoder Straight Shaft with Keyway 3000rpm maximum** MS Connectors	79	25	6.41	SGMGH-05ACA61	05AE	Stock	
			8.26	SGMGH-05ACA6C			
	122	48	12.30	SGMGH-09ACA61	10AE		
			14.15	SGMGH-09ACA6C			
	207	74	18.2	SGMGH-13ACA61	15AE		
			20.1	SGMGH-13ACA6C			
	254	102	28.1	SGMGH-20ACA61	20AE		
			35.9	SGMGH-20ACA6C			
	404	165	40.7	SGMGH-30ACA61	30AE		
			48.5	SGMGH-30ACA6C			
	630	252	59.8	SGMGH-44ACA61	50AE		
			67.6	SGMGH-44ACA6C			
	776	310	78.8	SGMGH-55ACA61	60AE Requires Regenerative Unit (E)		
			86.6	SGMGH-55ACA6C			
	1050	425	111	SGMGH-75ACA61	75AE Requires Regenerative Unit (E)		
			119	SGMGH-75ACA6C			
	1550	620	249	SGMGH-1AACA61	1AAE Requires Regenerative Unit (E)		Limited Stock
			267	SGMGH-1AACA6C			Non-stock
1988	845	279	SGMGH-1EACA61	1EAE Requires Regenerative Unit (E)	Limited Stock		
		309	SGMGH-1EACA6C		Non-stock		

Note: 24V_{DC} brakes for SGMGH Sigma II servomotors are standard. Contact a local source for 24V_{DC} power supplies.
For technical information, request request Yaskawa manual number YEA-SIA-S800-32.2.

* For more detailed SGD amplifier specifications and dimensions, refer to pages 99 to 112.

**2000rpm maximum for 11 and 15kW systems only.

200V Three-phase Sigma II Servo Systems

Pre-wired Cable Selection

Use the table below to select pre-wired cables for your SGMGH Sigma II servomotor.

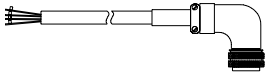
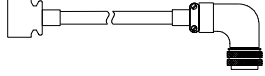
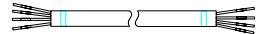
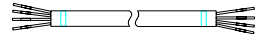
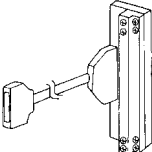
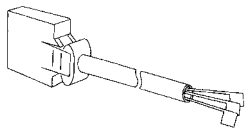
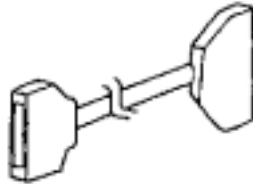
Cable Description (C)	Motor Size (kW)	Part Number*		Comments	Item Class
		without Brake	with Brake		
Power Cable with Connectors (IP67) 	0.5, 0.9, 1.3	B1E-□□(A)	B1BE-□□(A)	Use the following key to specify needed cable length (last two digits of the part number): 03: 3m 05: 5m 10: 10m (standard) 15: 15m 20: 20m	Stock***
	2.0, 3.0	B2E-□□(A)	B2BE-□□(A)		
	4.4	B3E-□□(A)	B3BE-□□(A)		
	5.5, 7.5**	B5E-□□(A)	B5E-□□(A) B7BCE-□□(A)		
	11, 15**	B6E-□□(A)	B6E-□□(A) B7BCE-□□(A)		
Encoder Cable (incremental or absolute) (IP67) 	All	JZSP-CMP02-□□(B)		These cables are available in five lengths. Use two digits in the part number's last place: 03: 3m 05: 5m 10: 10m (standard) 15: 15m 20: 20m	Stock***
Encoder Cable (for applications up to 20m) for solder connections 		FR-RMCT-SB		These cables are available in any length. For example, to order one FR-RMCT-SB cable, 16m long, specify: quantity: 16 part no.: FR-RMCT-SB	
Encoder Cable (for applications from >20 to <50m) for solder connections 		UL20276-SB			
Input/Output 1CN Cable & Transition Terminal Block 	All	JUSP-TA50P		35 mm DIN rail mountable; the cable length is 0.5m.	Stock***
Input/Output 1CN Cable with Pigtail Leads 		JZSP-CKI01-□(A)		Use the following key to specify needed cable length (last digit of part number): 1: 1m (standard) 2: 2m 3: 3m	
Input/Output 1CN Cable Cable with Female D-Sub output Connector**** 		JZSP-CKI0D-□□		Use the following key to specify required cable length (last two digits of the part number): D50: 0.5m 01: 1m (standard) 02: 2m 03: 3m	

* "(A)" at the end of the cable number is the revision level. The revision level may be changed prior to this catalog's reprinting.



** When ordering these cables for motors with brakes, order the standard power cable and the additional cable for the brake.

*** Standard cable lengths are Stock items; non-standard cable lengths are Limited Stock items.

**** 50 Pin Female D-Sub output connector mates to customer supplied third party terminal block. (e.g., Wago #289-449, Weidmuller #919658, Phoenix #2283647, Amphenol/Sine #20-51039, and many others).

Connector Selection

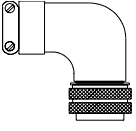
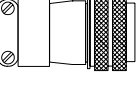
Use the table below to select mating connectors for each SGMGH Sigma II servomotor.

Connector Description (D)	Motor Size (kW)	Part Number		Comments	Item Class
		without Brake	with Brake		
MS Connector for Motor Power Cable* 	0.5, 0.9, 1.3	MS3106B18-10S	MS3106B20-15S	Straight-type connector	Stock
		MS3108B18-10S	MS3108B20-15S	L-type connector	
		MS3057-10A	MS3057-12A	Cable clamp	
	2.0, 3.0, 4.4	MS3106B22-22S	MS3106B24-10S	Straight-type connector	
		MS3108B22-22S	MS3108B24-10S	L-type connector	
		MS3057-12A	MS3057-16A	Cable clamp	
	5.5, 7.5, 1A, 1E	MS3106B32-17S	MS3106B32-17S and MS3106A10SL-3S	Straight-type connector	
		MS3108B32-17S	MS3108B32-17S and MS3108A10SL-3S	L-type connector	
		MS3057-20A	MS3057-20A MS3057-4A	Cable clamp	
MS Connector for Encoder Cable (incremental or absolute encoder) 	All	MS3106B20-29S		Straight-type connector	
		MS3108B20-29S		L-type connector	
		MS3057-12A		Cable clamp	
1CN Mating Connector 	All	JZSP-CKI9		—	
2CN Encoder Mating Connector 	All	JZSP-CMP9-1		—	
3CN Peripheral Mating Connector —	All	YSC-1		—	
5CN Connector and 1m Cable with Pig-tails —	All	DE9404559		Can use 5CN for analog speed and torque monitor service checks.	

* Choose either a straight or L-type connector and the associated cable clamp for a complete assembly. For example, L-type connector MS3108B18-10S is compatible with cable clamp MS3057-10A. MS connectors listed in the table are non-environmental.

Peripheral Device Selection

Use the table below to select peripheral devices for each SGMGH Sigma II servomotor.

Component (E)	Part Number	Description	Item Class
Hand-held Digital Operator Panel	JUSP-OP02A-1 and JZSP-CMS00-1	Portable unit with 1m adapter cable for Sigma II	Stock
Software Interface Cable	YS-12	Pre-wired 2.0m cable with 9-pin connector	
Absolute Encoder Battery	JZSP-BA01	3.6V, 1000mAh (Lithium Battery)	
	JZSP-BA01-1	For SGDH-60 and above (same as JZSP-BA01 with longer lead)	
SigmaWin+ Software	JZSP-WP0001	Minimum Recommended System Requirements Pentium 200 MHz, 64MB RAM, 200MB hard drive, CDROM Drive, RS-232 or RS-422 port, Screen resolution 800x600 w/ 256 colors, and Windows 95,98,NT4.0,2000,ME. (Windows XP planned)	
Regenerative Unit for 6.0kW amplifier (880W)	JUSP-RA04	These are general purpose regenerative units.* Order the Motion document: PI#99004 for setup instructions for this unit. Caution: Proper set-up is necessary to avoid equipment damage.	Limited Stock
Regenerative Unit for 7.5, 11, and 15kW amplifiers (1760W)	JUSP-RA05		
DC Reactor (for suppressing harmonics in the power supply)	For 200V: SGDH-05AE SGDH-08AE SGDH-10AE	X5061	
	SGDH-15AE SGDH-20AE	X5060	
	SGDH-30AE SGDH-50AE	X5059 X5068	

* For an alternate solution, specify the individual resistor part number RH500N25_OHMK in necessary series or parallel connection. Refer to the SGDH servo amplifier section of this catalog for additional specifications, and the *Sigma II Series Servo System User's Manual* (YEA-SIA-S800-32.2) for proper resistor sizing guidelines.

CE Pre-wired Cable Selection

Use the table below to select shielded pre-wired power cables for your SGMGH Sigma II servomotor.

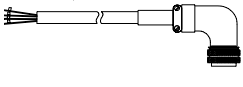
Cable Description (C)		Motor Size (kW)	Part Number*		Comments	Item Class
			without Brake	with Brake		
Power Cable with Connectors IP67		0.5, 0.9, 1.3	B1CE-□□(A)	B1BCE-□□(A)	Use the following key to specify needed cable length (last two digits of the part number): 03: 3m 05: 5m 10: 10m (standard) 15: 15m 20: 20m	Limited Stock
		2.0, 3.0	B2CE-□□(A)	B3BCE-□□(A)		
		4.4	B3CE-□□(A)			
		5.5, 7.5	B5CE-□□(A)	B5CE-□□(A) B7BCE-□□(A)		
		11, 15	B6CE-□□(A)	B6CE-□□(A) B7BCE-□□(A)		

* "(A)" at the end of the cable number is the revision level, which may be changed prior to this catalog's reprinting.

CE Connector Selection

Use the table below to select mating connectors for your SGMGH Sigma II servomotor.

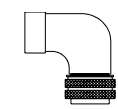
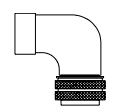
Connector Description (D)		Motor Size (kW)	Part Number		Comments**	Item Class
			without Brake	with Brake		
Connector for Motor Power Cable*		0.5, 0.9, 1.3	CE05-8A18-10SD-B-BAS CE3057-10A-1(D265)	CE05-8A20-15SD-B-BAS CE3057-12A-1(D265)	L-type connector Cable clamp	Limited Stock
		2.0, 3.0, 4.4	CE05-8A22-22SD-B-BAS CE3057-12A-1(D265)	CE05-8A24-10SD-B-BAS CE3057-16A-1(D265)	L-type connector Cable clamp	
		5.5, 7.5, 11, 15	CE05-8A32-17SD-B-BAS or CE05-6A32-17SD-B-BSS and CE3057-20A-1		L-type connector or Straight-type connector and Cable clamp (diameters 0.866 to 0.937in)	
Connector for Holding Brake		All	CE05-8A10SL-3SC-B-BAS and CE3057-4A-1 (D265)		L-type connector for holding brake and Cable clamp (diameters 0.142 to 0.220in)	
Connector for Encoder Cable (incremental or absolute encoder)		All	CE02-6A20-29NSW and CE20BA-S and CE3057-12A-3(D265)		L-type connector (plug and back shell) and Cable clamp (diameters 0.265 to 0.394in)	

* Choose the connector and the associated cable clamp for a complete assembly. Connectors listed in this table are environmentally sealed.

** Connectors are manufactured by DDK and listed here with the largest standard cable clamp available.

SGMGH Gearmotors (1500rpm) - With Incremental/Absolute Encoder

Rated Output: 0.45kW, 0.85kW,
1.3kW, 1.8kW, 2.9kW,
4.4kW, 5.5kW, 7.5kW



For Additional Information	Page(s)
SGMGH Gearmotor Ratings & Specifications	70 -73
SGMGH Gearmotor Dimensions	74 -76
SGMGH Gearmotor Selection/Ordering Information	77 -83

Design Features

- 1. Compact**
 - Fits in limited mounting space
 - High torque to inertia ratio
- 2. Torque**
 - 383 to 30,090in • lb peak torque
 - Uses time-proven, Sigma motor technology
- 3. Encoders**
 - 17-Bit (32,768 ppr x 4) incremental encoder (standard)
 - 17-Bit absolute encoder (option)
- 4. Enhanced Environmental Resistance**
 - Totally enclosed, self-cooled IP67 (not including shaft)
- 5. Application Emphasis**
 - Machine tools, woodworking machines, and thermoforming machines
 - Roll feeders
 - Press automation
 - Gantry robots
 - PCB drilling machines
 - Packaging machines
- 6. Certified International Standards**
 - cUL recognized (File #: E165827), CE compliance

Gearmotor Ratings and Specifications

GEARMOTOR Part Number	Rated Torque (in · lb)	Peak Torque (in · lb)	Rated Speed (rpm)	Maximum Speed (rpm)	Speed N1 (rpm)	Torque T1 (in · lb)	Torque T2 (in · lb)
Standard SGMGH Gearmotors							
SG05SA-GA05AC	122	383	300	600	440	61	206
SG10SA-GA05AC	244	637	150	300	220	122	412
SG25SA-GA05AC	597	1770	60	120	88	298	1009
SG50SA-GA05AC	1194	3540	30	60	44	597	2018
SG05SA-GA09AC	231	592	300	600	560	116	498
SG10SA-GA09AC	463	1,185	150	300	280	232	996
SG25SA-GA09AC	1133	2901	60	120	112	568	2438
SG50SA-GA09AC	2266	3540	30	60	60	1135	3540
SG05SA-GA13AC	358	1000	300	600	550	179	721
SG10SA-GA13AC	716	1593	150	300	275	358	1442
SG25SA-GA13AC	1753	3540	60	120	110	877	3531
SG05SA-GA20AC	494	1232	300	600	560	244	1052
SG10SA-GA20AC	987	2464	150	300	280	494	2103
SG05SA-GA30AC	798	1936	300	600	500	399	1361
SG05SA-GA44AC	1219	3052	300	600	470	610	1829
SG05SA-GA55AC	1502	3540	300	600	450	751	2314
SG05SA-GA75AC	2060	3540	300	600	500	1030	2374
Precision SGMGH Gearmotors							
SH04SA-GA05AC	98	306	375	750	550	49	165
SH05SA-GA05AC	122	383	300	600	440	61	206
SH07SA-GA05AC	171	536	214	429	314	85	288
SH10SA-GA05AC	244	708	150	300	220	122	412
SH16SA-GA05AC	378	885	94	188	138	189	639
SH20SA-GA05AC	473	1484	75	150	110	236	799
SH28SA-GA05AC	662	2,078	54	107	79	331	1118
SH40SA-GA05AC	945	2,213	38	75	55	473	1597
SH50SA-GA05AC	1,181	2,213	30	60	44	591	1997
SH70SA-GA05AC	1,654	4,425	21	43	31	827	2795
SH04SA-GA09AC	185	474	375	750	700	93	389
SH05SA-GA09AC	231	592	300	600	560	116	498
SH07SA-GA09AC	324	829	214	429	400	162	697
SH10SA-GA09AC	463	1185	150	300	280	232	996
SH16SA-GA09AC	717	1837	94	188	175	363	1561
SH20SA-GA09AC	897	2213	75	150	140	454	1951
SH28SA-GA09AC	1,256	2213	54	107	107	636	2213
SH40SA-GA09AC	1794	4425	38	75	70	908	3901
SH50SA-GA09AC	2242	4425	30	60	60	1135	4425
SH04SA-GA13AC	286	800	375	750	688	143	577
SH05SA-GA13AC	358	1000	300	600	550	179	721
SH07SA-GA13AC	501	1400	214	429	393	251	1010
SH10SA-GA13AC	716	1770	150	300	275	358	1442
SH16SA-GA13AC	1110	2213	94	188	188	555	2213
SH20SA-GA13AC	1388	3877	75	150	138	694	2795
SH28SA-GA13AC	1943	4425	54	107	98	971	3914
SH40SA-GA13AC	2775	7753	38	75	69	1388	5591
SH04SA-GA20AC	395	986	375	750	700	197	841
SH05SA-GA20AC	494	1232	300	600	560	247	1052
SH07SA-GA20AC	691	1725	214	429	400	346	1472
SH10SA-GA20AC	987	2464	150	300	280	494	2103
SH16SA-GA20AC	1531	3820	94	188	175	756	3261

200V Three-phase Sigma II Servo Systems

GEARMOTOR Part Number	Rated Torque (in · lb)	Peak Torque (in · lb)	Rated Speed (rpm)	Maximum Speed (rpm)	Speed N1 (rpm)	Torque T1 (in · lb)	Torque T2 (in · lb)
SH20SA-GA20AC	1913	4425	75	150	140	957	4077
SH28SA-GA20AC	2679	4425	54	107	107	1339	4425
SH40SA-GA20AC	3827	9550	38	75	70	1913	8153
SH50SA-GA20AC	4783	9735	30	60	60	2392	9735
SH04SA-GA30AC	639	1549	375	750	625	319	1089
SH05SA-GA30AC	798	1936	300	600	500	399	1361
SH07SA-GA30AC	1118	2710	214	429	357	559	1905
SH10SA-GA30AC	1597	3540	150	300	250	798	2721
SH16SA-GA30AC	2476	4425	94	188	156	1238	4220
SH20SA-GA30AC	3095	7504	75	150	125	1547	5275
SH28SA-GA30AC	4333	9735	54	107	89	2166	7384
SH40SA-GA30AC	6189	9735	38	75	75	3095	9735
SH04SA-GA44AC	975	2441	375	750	588	488	1463
SH05SA-GA44AC	1219	3052	300	600	470	610	1829
SH07SA-GA44AC	1707	4273	214	429	336	853	2560
SH10SA-GA44AC	2438	6104	150	300	235	1219	3657
SH16SA-GA44AC	3780	9464	94	188	147	1890	5671
SH20SA-GA44AC	4725	9735	75	150	118	2363	7088
SH04SA-GA55AC	1202	3008	375	750	563	601	1851
SH05SA-GA55AC	1502	3760	300	600	450	751	2314
SH07SA-GA55AC	2103	5264	214	429	321	1052	3239
SH10SA-GA55AC	3005	7520	150	300	225	1502	4627
SH04SA-GA75AC	1648	4086	375	750	625	824	1899
SH05SA-GA75AC	2060	5108	300	600	500	1030	2374
SH07SA-GA75AC	2884	7151	214	429	357	1442	3323
SH10SA-GA75AC	4121	7789	150	300	250	2060	4748

SGMGH
Gearmotors

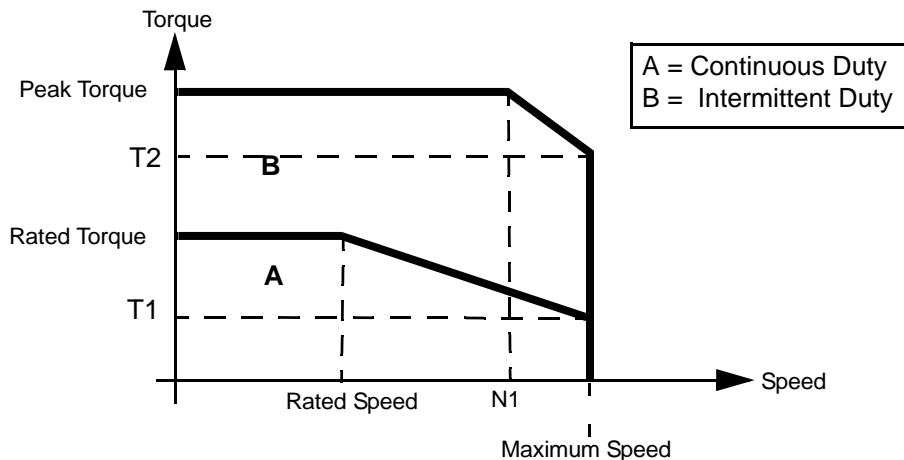

Gearmotor Mechanical Ratings

GEARMOTOR Part Number	Gearhead Backlash (arc min)	Gearhead Maximum Radial Load (lb _f)	Gearhead Maximum Axial Load (lb _f)	Gearhead Inertia (lb · n · s ²)	Approx. Gearmotor Weight (lb)		
Standard SGMGH Gearmotors							
SG05SA-GA05AC	<10	540	428	0.0016	21.14		
SG10SA-GA05AC							
SG25SA-GA05AC		1035	900	0.0049	36.80		
SG50SA-GA05AC		1687	1350	0.0047	58.30		
SG05SA-GA09AC		540	428	0.0016	25.84		
SG10SA-GA09AC		1035	900	0.0048	36.65		
SG25SA-GA09AC		1687	1350	0.0047	63.00		
SG50SA-GA09AC							
SG05SA-GA13AC		1035	900	0.0048	41.05		
SG10SA-GA13AC							
SG25SA-GA13AC		1687	1350	0.0047	67.40		
SG05SA-GA20AC		1687	1350	0.022	69.49		
SG10SA-GA20AC							
SG05SA-GA30AC		1687	1350	0.022	78.29		
SG05SA-GA44AC		1687	1350	0.022	89.29		
SG05SA-GA55AC		1687	1350	0.022	104.69		
SG05SA-GA75AC	1687	1350	0.022	126.71			
Precision SGMGH Gearmotors							
SH04SA-GA05AC	<6		720	0.000558	18.30		
SH05SA-GA05AC				0.000487	18.30		
SH07SA-GA05AC				0.000434	18.30		
SH10SA-GA05AC				0.000407	18.30		
SH16SA-GA05AC				0.000522	18.90		
SH20SA-GA05AC				1350	1215	0.00159	27.80
SH28SA-GA05AC		1350	1215	0.00159	27.80		
SH40SA-GA05AC				0.00106	27.80		
SH50SA-GA05AC				2025	2115	0.00239	44.10
SH70SA-GA05AC							
SH04SA-GA09AC		855	720	0.000558	23.00		
SH05SA-GA09AC				0.000487			
SH07SA-GA09AC				0.000434			
SH10SA-GA09AC				0.00115			
SH16SA-GA09AC		1350	1215	0.00159	30.50		
SH20SA-GA09AC							
SH28SA-GA09AC							
SH40SA-GA09AC	2025			2115	0.00239	48.80	
SH50SA-GA09AC							
SH04SA-GA13AC	<4	1350	1215	0.00239	34.90		
SH05SA-GA13AC				0.00212			
SH07SA-GA13AC				0.00186			
SH10SA-GA13AC				0.00177			
SH16SA-GA13AC				0.00221			
SH20SA-GA13AC	<6	2025	2115	0.004514	53.20		
SH28SA-GA13AC							
SH40SA-GA13AC		3150	3038	0.003098	85.10		
SH04SA-GA20AC	<4	2025	2115	0.007257	56.30		
SH05SA-GA20AC				0.006461			
SH07SA-GA20AC				0.005753			
SH10SA-GA20AC				0.00531			
SH16SA-GA20AC	<6	3150	3038	0.006726	62.90		
SH20SA-GA20AC							
SH28SA-GA20AC							
SH40SA-GA20AC							
SH50SA-GA20AC				0.00531	94.80		

200V Three-phase Sigma II Servo Systems

GEARMOTOR Part Number	Gearhead Backlash (arc min)	Gearhead Maximum Radial Load (lb _f)	Gearhead Maximum Axial Load (lb _f)	Gearhead Inertia (lb · in · s ²)	Approx. Gearmotor Weight (lb)			
Precision SGMGH Gearmotors								
SH04SA-GA30AC	<4	2025	2115	0.00726	65.10			
SH05SA-GA30AC				0.00646				
SH07SA-GA30AC				0.00575				
SH10SA-GA30AC				0.00531				
SH16SA-GA30AC	<6	3150	3038	0.006726	71.70			
SH20SA-GA30AC				0.00708	103.60			
SH28SA-GA30AC				0.0069				
SH40SA-GA30AC				0.00531				
SH04SA-GA44AC	<4	3150	3038	0.0281	110.20			
SH05SA-GA44AC				0.023				
SH07SA-GA44AC				0.0187				
SH10SA-GA44AC				0.0164				
SH16SA-GA44AC	<6	3150	3038	0.00726	114.60			
SH20SA-GA44AC				0.00708				
SH04SA-GA55AC				<4		3150	3038	0.03204
SH05SA-GA55AC								0.02699
SH07SA-GA55AC	0.02266							
SH10SA-GA55AC	0.02036							
SH04SA-GA75AC	<4	3150	3038	0.03204	147.62			
SH05SA-GA75AC				0.02699				
SH07SA-GA75AC				0.02266				
SH10SA-GA75AC				0.02036				

SGMGH Gearmotors

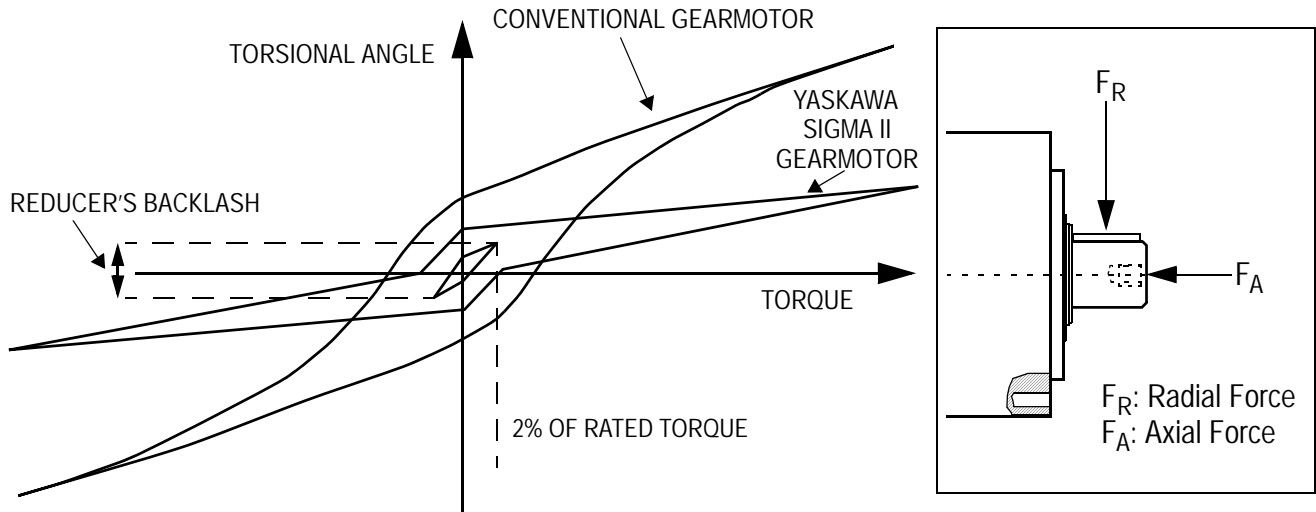

Dimensions in inches (mm)

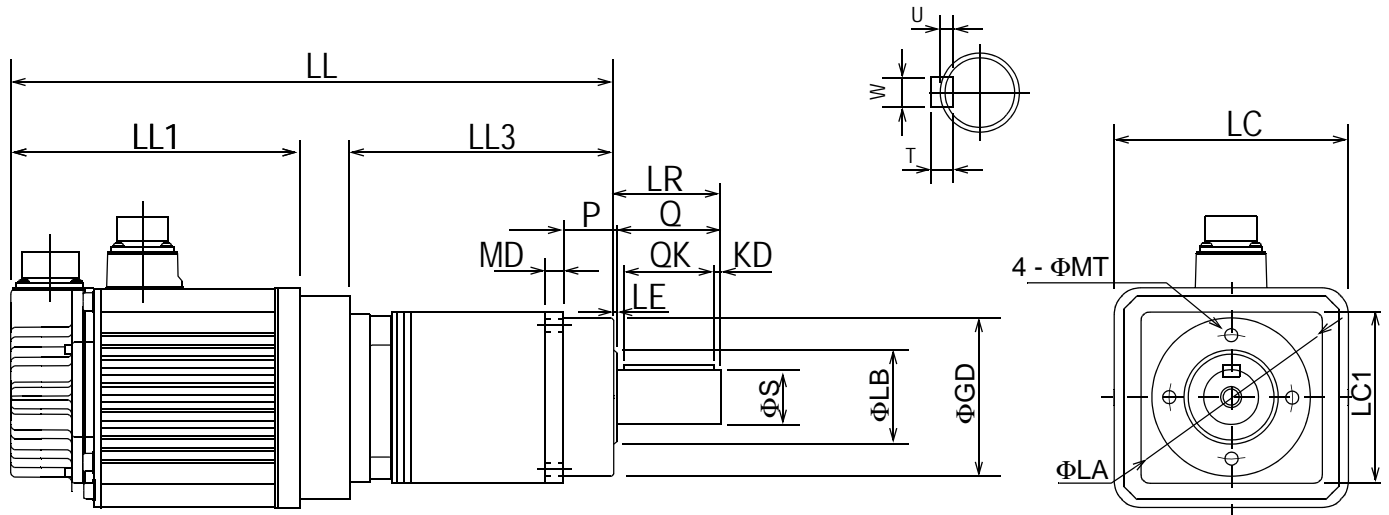

• Standard SGMGH Gearmotors

GEARMOTOR	LL1	LL3	LL	LE	LR	ΦLB	ΦGD	ΦS	P	LC	LC1	ΦLA	ΦMT*	MD*	Q	OK	KD	W	T	U		
SG05SA-GA05AC	5.43 (138)	3.15 (80)	10.83 (275)	0.20 (5)	1.81 (46)	2.68 (68)	3.54 (90)	0.87 (22)	N/A	5.12 (130)	N/A	3.15 (80)	M6 x 1.0	0.47 (12)	1.42 (36)	1.26 (32)	0.08 (2)	0.24 (6)	0.24 (6)	0.14 (3.5)		
SG10SA-GA05AC		5.30 (134.5)	12.62 (320.5)	0.24 (6)	2.76 (70)	3.54 (90)	4.72 (120)	1.26 (32)				4.25 (108)	M8 x 1.25	0.63 (16)	2.28 (58)	1.97 (50)	0.16 (4)	0.39 (10)	0.32 (8)	0.20 (5)		
SG25SA-GA05AC		6.02 (153)	13.35 (339)	0.32 (8)	3.82 (97)	4.72 (120)	6.10 (155)	1.58 (40)				5.51 (140)	M10 x 1.5	0.79 (20)	3.23 (82)	2.76 (70)	0.24 (6)	0.47 (12)				
SG50SA-GA05AC	3.15 (80)	11.73 (298)	0.20 (5)	1.81 (46)	2.68 (68)	3.54 (90)	0.87 (22)	N/A				7.48 (190)	N/A	3.15 (80)	M6 x 1.0	0.47 (12)	1.42 (36)	1.26 (32)	0.08 (2)	0.24 (6)	0.24 (6)	0.14 (3.5)
SG05SA-GA09AC	4.02 (102)	12.24 (311)	0.24 (6)	2.76 (70)	3.54 (90)	4.72 (120)	1.26 (32)							4.25 (108)	M8 x 1.25	0.63 (16)	2.28 (58)	1.97 (50)	0.16 (4)	0.39 (10)	0.32 (8)	0.20 (5)
SG10SA-GA09AC	6.02 (153)	14.25 (362)	0.32 (8)	3.82 (97)	4.72 (120)	6.10 (155)	1.58 (40)							5.51 (140)	M10 x 1.5	0.79 (20)	3.23 (82)	2.76 (70)	0.24 (6)	0.47 (12)		
SG25SA-GA09AC	4.02 (102)	13.19 (335)	0.24 (6)	2.76 (70)	3.54 (90)	4.72 (120)	1.26 (32)							N/A	N/A	N/A	4.25 (108)	M8 x 1.25	0.63 (16)	2.28 (58)	1.97 (50)	0.16 (4)
SG50SA-GA09AC	6.02 (153)	15.20 (386)	0.32 (8)	3.82 (97)	4.72 (120)	6.10 (155)	1.58 (40)	N/A				N/A	N/A				N/A	N/A	N/A	N/A	N/A	N/A
SG05SA-GA13AC	7.28 (185)	6.02 (153)												15.20 (386)	4.25 (108)	M8 x 1.25						
SG10SA-GA13AC	7.28 (185)	6.02 (153)	15.20 (386)	4.25 (108)	M8 x 1.25	0.63 (16)	2.28 (58)	1.97 (50)				0.16 (4)	0.39 (10)									
SG25SA-GA13AC	7.28 (185)	6.02 (153)	15.20 (386)	4.25 (108)	M8 x 1.25	0.63 (16)	2.28 (58)	1.97 (50)				0.16 (4)	0.39 (10)									
SG05SA-GA20AC	6.54 (166)	4.82 (122.5)	13.92 (353.5)	0.32 (8)	3.82 (97)	4.72 (120)	6.10 (155)	1.58 (40)				N/A	N/A	N/A	N/A	N/A	N/A	N/A	N/A	N/A	N/A	N/A
SG10SA-GA20AC	7.56 (192)		14.94 (379.5)						4.25 (108)	M8 x 1.25	0.63 (16)											
SG05SA-GA30AC	8.90 (226)	16.28 (413.5)	4.25 (108)	M8 x 1.25	0.63 (16)	2.28 (58)	1.97 (50)	0.16 (4)	0.39 (10)													
SG05SA-GA44AC	10.24 (260)	19.00 (482.5)	4.25 (108)	M8 x 1.25	0.63 (16)	2.28 (58)	1.97 (50)	0.16 (4)	0.39 (10)													
SG05SA-GA55AC	13.15 (334)	21.91 (556.5)	4.25 (108)	M8 x 1.25	0.63 (16)	2.28 (58)	1.97 (50)	0.16 (4)	0.39 (10)													
SG05SA-GA75AC	13.15 (334)	21.91 (556.5)	4.25 (108)	M8 x 1.25	0.63 (16)	2.28 (58)	1.97 (50)	0.16 (4)	0.39 (10)													

Note:* For Standard (SG) Gearmotors only: 4 x ΦMT threaded holes to a depth of dimension MD, set 90° apart.

Specified Tolerances for Standard (SG) Gearmotor Models:

Dimension	ΦS		ΦLB		W	
Unit	Diameter	Tolerance	Diameter	Tolerance	Width	Tolerance
in	0.472, 0.630	+0.00047 +0.00004	1.378	+0.00000 -0.00063	0.158, 0.197, 0.236	+0.00000 -0.00118
	0.866	+0.00059 +0.00008	2.047, 2.677	+0.00000 -0.00075	0.39370	+0.00000 -0.00142
	1.260, 1.575	+0.00071 +0.00008	3.54331, 4.72441	+0.00000 -0.00087	0.47244	+0.00000 -0.00169
mm	12, 16	+0.012 +0.001	35	+0.000 -0.016	4, 5, 6	+0.000 -0.030
	22	+0.015 +0.002	52, 68	+0.000 -0.019	10	+0.000 -0.036
	32, 40	+0.018 +0.002	90, 120	+0.000 -0.022	12	+0.000 -0.043

200V Three-phase Sigma II Servo Systems

• Precision SGMGH Gearmotors

GEARMOTOR	LL1	LL3	LL	LE	LR	ΦLB	ΦGD	ΦS	P	LC	LC1*	ΦLA	ΦMT**	MD**	Q	QK	KD	W	T	U																		
SH04SA-GA05AC	5.43 (138)	3.78 (96)	10.87 (276)	0.08 (2)	1.50 (38)	1.50 (38)	2.76 (70)	0.87 (22)	0.79 (20)	5.12 (130)	2.99 (76)	3.35 (85)	0.26 (6.6)	0.28 (7)	1.42 (36)	1.26 (32)	0.08 (2)	0.24 (6)	0.24 (6)	0.14 (3.5)																		
SH05SA-GA05AC																																						
SH07SA-GA05AC																																						
SH10SA-GA05AC																																						
SH16SA-GA05AC		4.82 (122.5)	11.91 (302.5)		2.36 (60)	2.17 (55)	3.54 (90)	1.26 (32)	1.18 (30)	3.98 (101)	4.72 (120)	0.35 (9)	0.39 (10)	2.28 (58)	1.97 (50)	0.16 (4)	0.39 (10)	0.32 (8)	0.20 (5)																			
SH20SA-GA05AC																																						
SH28SA-GA05AC		5.77 (146.5)	12.89 (327.5)		7.13 (181)	14.35 (364.5)	0.12 (3)	3.35 (85)	2.76 (70)	5.12 (130)	1.58 (40)	5.51 (140)	5.55 (141)	6.50 (165)	0.43 (11)	0.47 (12)	3.23 (82)	2.76 (70)	0.20 (5)	0.47 (12)																		
SH40SA-GA05AC																																						
SH50SA-GA05AC	7.13 (181)	14.35 (364.5)	6.34 (161)	0.08 (2)	2.36 (60)	2.17 (55)	3.54 (90)	1.26 (32)	0.79 (20)	5.12 (130)	2.99 (76)	3.35 (85)	0.26 (6.6)	0.28 (7)	1.42 (36)	1.26 (32)	0.08 (2)	0.24 (6)	0.24 (6)	0.14 (3.5)																		
SH04SA-GA09AC																																						
SH05SA-GA09AC																																						
SH07SA-GA09AC																																						
SH10SA-GA09AC	4.49 (114)	12.52 (318)																			7.13 (181)	15.26 (387.5)	0.12 (3)	3.35 (85)	2.76 (70)	5.12 (130)	1.58 (40)	5.51 (140)	5.55 (141)	6.50 (165)	0.43 (11)	0.47 (12)	3.23 (82)	2.76 (70)	0.20 (5)	0.47 (12)		
SH16SA-GA09AC																																						
SH20SA-GA09AC	5.77 (146.5)	13.80 (350.5)																			7.283 (185)	0.08 (2)	2.36 (60)	2.17 (55)	3.54 (90)	1.26 (32)	0.79 (20)	5.12 (130)	3.98 (101)	4.72 (120)	0.35 (9)	0.39 (10)	2.28 (58)	1.97 (50)	0.16 (4)	0.39 (10)	0.32 (8)	0.20 (5)
SH28SA-GA09AC																																						
SH40SA-GA09AC																																						
SH50SA-GA09AC																																						
SH04SA-GA13AC	4.49 (114)	13.47 (342)	7.13 (181)	16.20 (411.5)	0.12 (3)	3.35 (85)	2.76 (70)	5.12 (130)	1.58 (40)	5.51 (140)	5.55 (141)	6.50 (165)	0.43 (11)	0.47 (12)	3.23 (82)	2.76 (70)	0.20 (5)	0.47 (12)																				
SH05SA-GA13AC																																						
SH07SA-GA13AC	5.77 (146.5)	14.74 (374.5)	7.87 (200)	16.95 (430.5)	0.12 (3)	3.35 (85)	2.76 (70)	5.12 (130)	1.58 (40)	7.17 (182)	8.47 (215)	0.51 (13)	0.59 (15)	3.23 (82)	2.76 (70)	0.24 (6)	0.63 (16)	0.39 (10)	0.24 (6)																			
SH10SA-GA13AC																																						
SH16SA-GA13AC	7.13 (181)	16.40 (416.5)	7.87 (200)	17.42 (442.5)	0.12 (3)	3.35 (85)	2.76 (70)	5.12 (130)	1.58 (40)	7.17 (182)	8.47 (215)	0.51 (13)	0.59 (15)	3.23 (82)	2.76 (70)	0.24 (6)	0.63 (16)	0.39 (10)	0.24 (6)																			
SH20SA-GA13AC																																						
SH28SA-GA13AC	7.87 (200)	16.95 (430.5)	7.87 (200)	16.95 (430.5)	0.12 (3)	3.35 (85)	2.76 (70)	5.12 (130)	1.58 (40)	7.17 (182)	8.47 (215)	0.51 (13)	0.59 (15)	3.23 (82)	2.76 (70)	0.24 (6)	0.63 (16)	0.39 (10)	0.24 (6)																			
SH40SA-GA13AC																																						
SH04SA-GA20AC	6.535 (166)	5.55 (141)	14.08 (357.5)	0.12 (3)	3.35 (85)	2.76 (70)	5.12 (130)	1.58 (40)	1.18 (30)	7.48 (190)	5.55 (141)	6.50 (165)	0.43 (11)	0.47 (12)	3.23 (82)	2.76 (70)	0.20 (5)	0.47 (12)	0.32 (8)	0.20 (5)																		
SH05SA-GA20AC																																						
SH07SA-GA20AC																																						
SH10SA-GA20AC																																						
SH16SA-GA20AC		7.13 (181)	15.65 (397.5)																		7.87 (200)	16.40 (416.5)	0.12 (3)	3.35 (85)	2.76 (70)	5.12 (130)	1.58 (40)	7.17 (182)	8.47 (215)	0.51 (13)	0.59 (15)	3.23 (82)	2.76 (70)	0.24 (6)	0.63 (16)	0.39 (10)	0.24 (6)	
SH20SA-GA20AC																																						
SH28SA-GA20AC		7.87 (200)	16.40 (416.5)																		7.87 (200)	16.40 (416.5)	0.12 (3)	3.35 (85)	2.76 (70)	5.12 (130)	1.58 (40)	7.17 (182)	8.47 (215)	0.51 (13)	0.59 (15)	3.23 (82)	2.76 (70)	0.24 (6)	0.63 (16)	0.39 (10)	0.24 (6)	
SH40SA-GA20AC																																						
SH50SA-GA20AC	7.56 (192)	5.55 (141)	15.10 (383.5)	0.12 (3)	3.35 (85)	2.76 (70)	5.12 (130)	1.58 (40)	1.18 (30)	7.48 (190)	5.55 (141)	6.50 (165)	0.43 (11)	0.47 (12)	3.23 (82)	2.76 (70)	0.20 (5)	0.47 (12)	0.32 (8)	0.20 (5)																		
SH04SA-GA30AC																																						
SH05SA-GA30AC																																						
SH07SA-GA30AC																																						
SH10SA-GA30AC																																						
SH16SA-GA30AC		7.13 (181)	16.67 (423.5)																		7.87 (200)	17.42 (442.5)	0.12 (3)	3.35 (85)	2.76 (70)	5.12 (130)	1.58 (40)	7.17 (182)	8.47 (215)	0.51 (13)	0.59 (15)	3.23 (82)	2.76 (70)	0.24 (6)	0.63 (16)	0.39 (10)	0.24 (6)	
SH20SA-GA30AC																																						
SH28SA-GA30AC		7.87 (200)	17.42 (442.5)																		7.87 (200)	17.42 (442.5)	0.12 (3)	3.35 (85)	2.76 (70)	5.12 (130)	1.58 (40)	7.17 (182)	8.47 (215)	0.51 (13)	0.59 (15)	3.23 (82)	2.76 (70)	0.24 (6)	0.63 (16)	0.39 (10)	0.24 (6)	
SH40SA-GA30AC																																						

SGMGH Gearmotors

200V Three-phase Sigma II Servo Systems

• Precision SGMGH Gearmotors (Continued)

GEARMOTOR	LL1	LL3	LL	LE	LR	ΦLB	ΦGD	ΦS	P	LC	LC1*	ΦLA	ΦMT**	MD**	Q	QK	KD	W	T	U		
SH04SA-GA44AC	8.90 (226)	6.87 (174.5)	17.24 (438)	0.12 (3)	3.35 (85)	3.54 (90)	6.30 (160)	2.17 (55)	1.18 (30)	7.48 (190)	7.17 (182)	8.47 (215)	0.51 (13)	0.59 (15)	3.23 (82)	2.76 (70)	0.24 (6)	0.63 (16)	0.39 (10)	0.24 (6)		
SH05SA-GA44AC																						
SH07SA-GA44AC																						
SH10SA-GA44AC																						
SH16SA-GA44AC																						
SH20SA-GA44AC																						
SH04SA-GA55AC	10.24 (260)	6.87 (174.5)	19.96 (507)		0.12 (3)	3.35 (85)	3.54 (90)	6.30 (160)	2.17 (55)		1.18 (30)	7.48 (190)	7.17 (182)	8.47 (215)	0.51 (13)	0.59 (15)	3.23 (82)	2.76 (70)	0.24 (6)	0.63 (16)	0.39 (10)	0.24 (6)
SH05SA-GA55AC																						
SH07SA-GA55AC																						
SH10SA-GA55AC																						
SH04SA-GA75AC	13.15 (334)	6.87 (174.5)	22.87 (581)	0.12 (3)		3.35 (85)	3.54 (90)	6.30 (160)	2.17 (55)	1.18 (30)	7.48 (190)		7.17 (182)	8.47 (215)	0.51 (13)	0.59 (15)	3.23 (82)	2.76 (70)	0.24 (6)	0.63 (16)	0.39 (10)	0.24 (6)
SH05SA-GA75AC																						
SH07SA-GA75AC																						
SH10SA-GA75AC																						

Note: * LC1 may be greater than LC, despite the depiction on the gearmotor drawing.

** For Precision (SH) Gearmotors only: 4 x ΦMT "thru holes" at a depth of dimension MD, set 90° apart.

Specified Tolerances for Precision (SH) Gearmotor Models:

Dimension	ΦS		ΦGD		W	
	Diameter	Tolerance	Diameter	Tolerance	Width	Tolerance
in	0.86614	+0.00059 +0.00008	2.75591	-0.00039 -0.00114	0.1685, 0.23622	+0.00000 -0.00118
	1.25984, 1.57480	+0.00071 +0.00008	3.54331	-0.00047 -0.00134	0.39370	+0.00000 -0.00142
	2.16535, 2.95276	+0.00083 +0.00008	5.11811, 6.29921, 7.08661	-0.00055 -0.00154	0.47244, 0.62992	+0.00000 -0.00169
	3.34646	+0.00098, +0.00012	7.87402	-0.00059 -0.00173	0.787400, 0.86614	+0.00000 -0.00205
mm	22	+0.015 +0.002	70	-0.010 -0.029	5, 6	+0.000 -0.030
	32, 40	+0.018 +0.002	90	-0.012 -0.034	10	+0.000 -0.036
	55, 75	+0.021 +0.002	130, 160, 180	-0.014 -0.039	12, 16	+0.000 -0.043
	85	+0.025 +0.003	200	-0.015 -0.044	20, 22	+0.000 -0.052

Selecting Your SGMGH Gearmotor System

First, select the Sigma II servomotor suited for your application using SigmaSize: the Yaskawa servomotor sizing software, available at no charge. (Request SigmaSize software via e-mail, at: literature@yaskawa.com).

Use the diagram below to locate and identify the components of your system. Each item is letter-coded and cross-referenced in the option tables on the following pages.

System Configuration

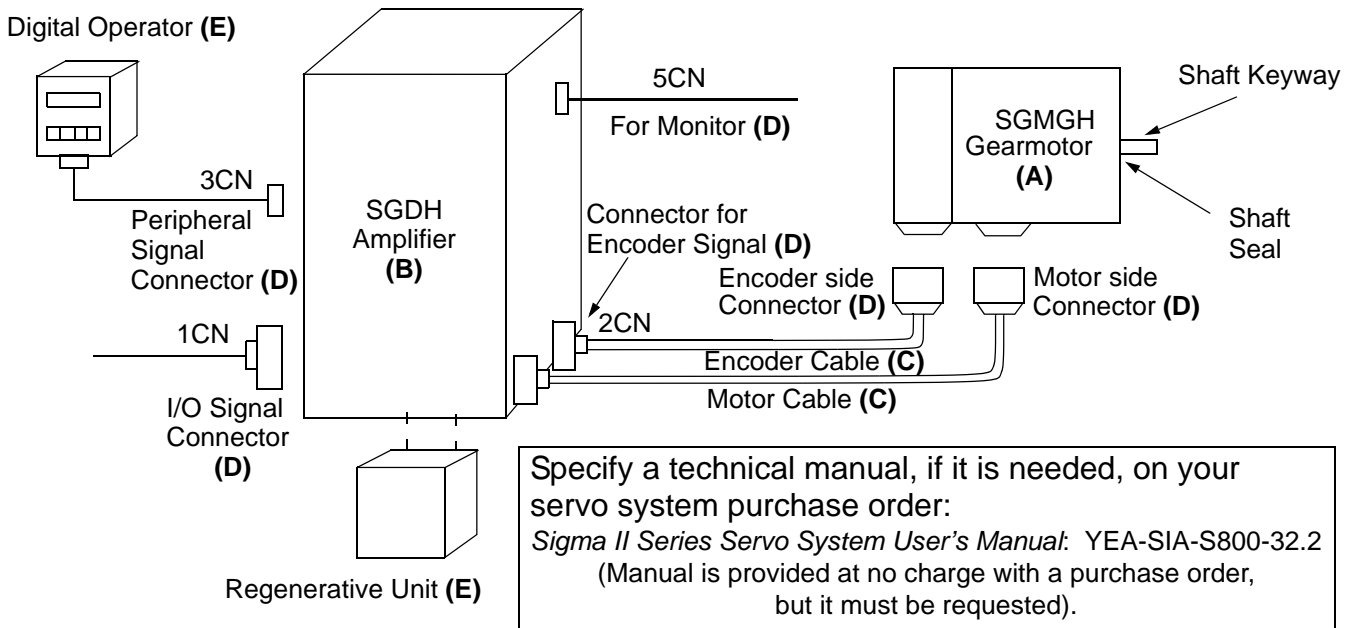

SGMGH Gearmotors

Model Number Designation

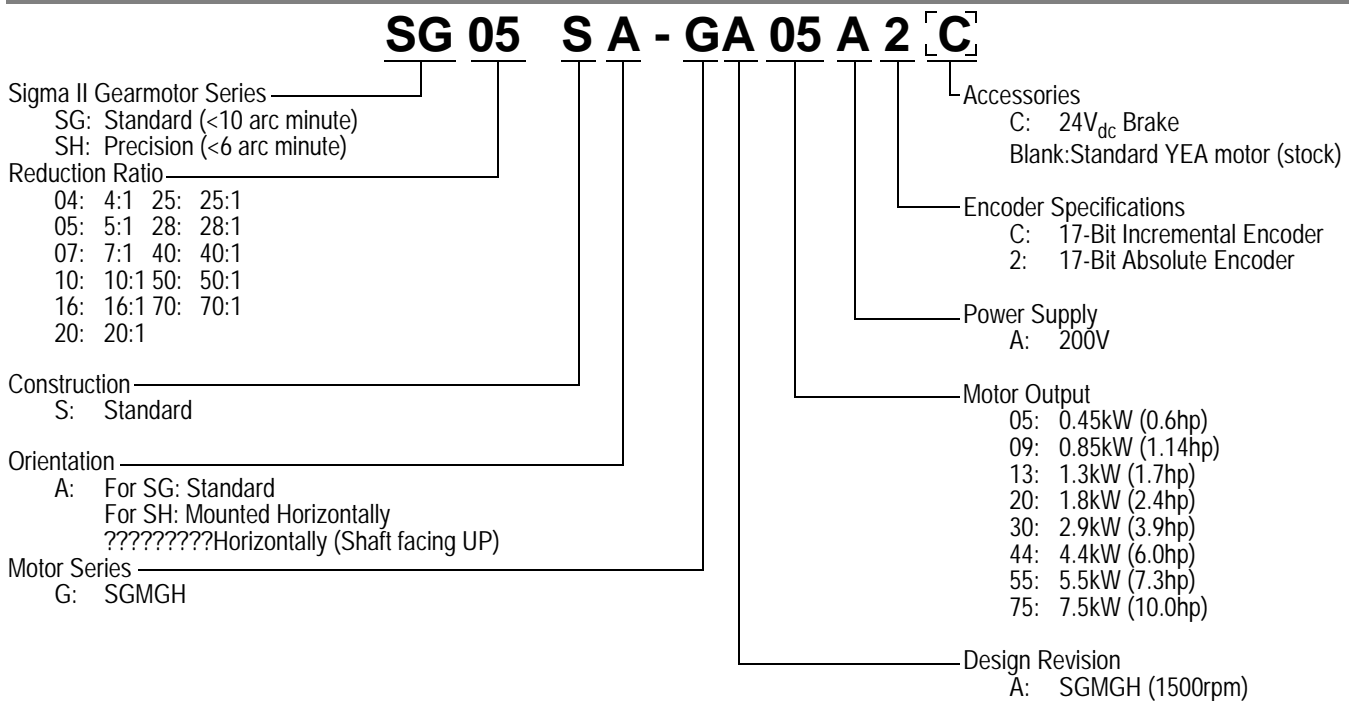

200V Three-phase Sigma II Servo Systems

Gearmotor & Amplifier Selection

Use this table below to select the appropriate SGMGH Sigma II gearmotor and amplifier. [See notes on page 77.](#)

Description	Rated Torque (in · lb)	Peak Torque (in · lb)	Rated Speed (rpm)	Maximum Speed (rpm)	Gear Ratio	Gearmotor Model Number* (A)	Amplifier MODEL # SGDH- (B)**	Motor and Amplifier Item Class
Standard SGMGH Gearmotors								
200V, 3-phase 17-bit Incremental Encoder Straight Shaft with Keyway MS connectors	122	383	300	600	5:1	SG05SA-GA05AC	05AE	Gear-motor: 3-4 weeks Amplifier: Stock
	244	637	150	300	10:1	SG10SA-GA05AC		
	597	1770	60	120	25:1	SG25SA-GA05AC		
	1194	3540	30	60	50:1	SG50SA-GA05AC		
	231	592	300	600	5:1	SG05SA-GA09AC	10AE	
	463	1185	150	300	10:1	SG10SA-GA09AC		
	1133	2901	60	120	25:1	SG25SA-GA09AC		
	2266	3540	30	60	50:1	SG50SA-GA09AC		
	358	1000	300	600	5:1	SG05SA-GA13AC	15AE	
	716	1593	150	300	10:1	SG10SA-GA13AC		
	1753	3540	60	120	25:1	SG25SA-GA13AC		
	494	1232	300	600	5:1	SG05SA-GA20AC	20AE	
	987	2464	150	300	10:1	SG10SA-GA20AC		
	798	1936	300	600	5:1	SG05SA-GA30AC	30AE	
	1219	3052	300	600	5:1	SG05SA-GA44AC	50AE	
1502	3540	300	600	5:1	SG05SA-GA55AC	60AE		
2060	3540	300	600	5:1	SG05SA-GA75AC	75AE		
Precision SGMGH Gearmotors								
200V, 3-phase 17-bit Incremental Encoder Straight Shaft with Keyway MS connectors	98	306	375	750	4:1	SH04S□-GA05AC	05AE	Gear-motor: 6-8 weeks Amplifier: Stock
	122	383	300	600	5:1	SH05S□-GA05AC		
	171	536	214	429	7:1	SH07S□-GA05AC		
	244	708	150	300	10:1	SH10S□-GA05AC		
	378	885	94	188	16:1	SH16S□-GA05AC		
	473	1484	75	150	20:1	SH20S□-GA05AC		
	662	2078	54	107	28:1	SH28S□-GA05AC		
	945	2213	38	75	40:1	SH40S□-GA05AC		
	1181	2213	30	60	50:1	SH50S□-GA05AC		
	1654	4425	21	43	70:1	SH70S□-GA05AC		
	185	474	375	750	4:1	SH04S□-GA09AC	10AE	
	231	592	300	600	5:1	SH05S□-GA09AC		
	324	829	214	429	7:1	SH07S□-GA09AC		
	463	1185	150	300	10:1	SH10S□-GA09AC		
	717	1837	94	188	16:1	SH16S□-GA09AC		
	897	2213	75	150	20:1	SH20S□-GA09AC		
	1256	2213	54	107	28:1	SH28S□-GA09AC		
	1794	4425	38	75	40:1	SH40S□-GA09AC		
	2242	4425	30	60	50:1	SH50S□-GA09AC		
	286	800	375	750	4:1	SH04S□-GA13AC		
	358	1000	300	600	5:1	SH05S□-GA13AC	15AE	
	501	1400	214	429	7:1	SH07S□-GA13AC		
	716	1770	150	300	10:1	SH10S□-GA13AC		
	1110	2213	94	188	16:1	SH16S□-GA13AC		
	1388	3877	75	150	20:1	SH20S□-GA13AC		
	1943	4425	54	107	28:1	SH28S□-GA13AC		
	2775	7753	38	75	40:1	SH40S□-GA13AC		
	395	986	375	750	4:1	SH04S□-GA20AC	20AE	
	494	1232	300	600	5:1	SH05S□-GA20AC		
	691	1725	214	429	7:1	SH07S□-GA20AC		
987	2464	150	300	10:1	SH10S□-GA20AC			
1531	3820	94	188	16:1	SH16S□-GA20AC			
1913	4425	75	150	20:1	SH20S□-GA20AC			

200V Three-phase Sigma II Servo Systems

Description	Rated Torque (in · lb)	Peak Torque (in · lb)	Rated Speed (rpm)	Maximum Speed (rpm)	Gear Ratio	Gearmotor Model Number (A)	Amplifier MODEL # SGDH- (B)*	Motor and Amplifier Item Class
200V, 3-phase 17-bit Incremental Encoder Straight Shaft with Keyway MS connectors	2679	4425	54	107	28:1	SH28S□-GA20AC	20AE	Motor: Non Stock Amplifier: Stock
	3827	9550	38	75	40:1	SH40S□-GA20AC		
	4783	9735	30	60	50:1	SH50S□-GA20AC		
	395	986	375	750	4:1	SH04S□-GA20AC		
	494	1232	300	600	5:1	SH05S□-GA20AC		
	691	1725	214	429	7:1	SH07S□-GA20AC		
	987	2464	150	300	10:1	SH10S□-GA20AC		
	1531	3820	94	188	16:1	SH16S□-GA20AC		
	1913	4425	75	150	20:1	SH20S□-GA20AC		
	2679	4425	54	107	28:1	SH28S□-GA20AC		
	3827	9550	38	75	40:1	SH40S□-GA20AC		
	4783	9735	30	60	50:1	SH50S□-GA20AC		
	639	1549	375	750	4:1	SH04S□-GA30AC	30AE	
	798	1936	300	600	5:1	SH05S□-GA30AC		
	1118	2710	214	429	7:1	SH07S□-GA30AC		
	1597	3540	150	300	10:1	SH10S□-GA30AC		
	2476	4425	94	188	16:1	SH16S□-GA30AC		
	3095	7504	75	150	20:1	SH20S□-GA30AC		
	4333	9735	54	107	28:1	SH28S□-GA30AC	50AE	
	6189	9735	38	75	40:1	SH40S□-GA30AC		
	975	2441	375	750	4:1	SH04S□-GA44AC		
	1219	3052	300	600	5:1	SH05S□-GA44AC		
	1707	4273	214	429	7:1	SH07S□-GA44AC		
	2438	6104	150	300	10:1	SH10S□-GA44AC		
	3780	9464	94	188	16:1	SH16S□-GA44AC	60AE**	
	4725	9735	75	150	20:1	SH20S□-GA44AC		
	1202	3008	375	750	4:1	SH04S□-GA55AC		
	1502	3760	300	600	5:1	SH05S□-GA55AC		
	2103	5264	214	429	7:1	SH07S□-GA55AC		
	3005	7520	150	300	10:1	SH10S□-GA55AC	75AE**	
1648	4086	375	750	4:1	SH04S□-GA75AC			
2060	5108	300	600	5:1	SH05S□-GA75AC			
2884	7151	214	429	7:1	SH07S□-GA75AC			
4121	7789	150	300	10:1	SH10S□-GA75AC			

SGMGH Gearmotors

Notes: 1. These performance ratings apply when duty cycles are 60% or less, and when the gearmotor runs for 1,000 cycles per hour or less. Contact your Yaskawa representative when duty cycles exceed 60%, and when the gearmotor runs for more than 1,000 cycles per hour.

- Rated Speed is at 20°C ambient temperature. Reduce Rated Speed by 20% at 40°C ambient temperature.
- For right-angle gearmotors, please consult the factory for availability.
- 24V_{DC} brakes for SGMGH Sigma II gearmotors are standard. Contact a local source for 24V_{DC} power supplies.
- For technical information, request Yaskawa manual number YEA-SIA-S800-32.2.

* To complete the model number in type SH gearmotors, please specify the shaft orientation as shown in the [Model Number Designation on page 75](#).

** For more detailed SGDH amplifier specifications and dimensions, refer to pages 99-112.

** Amplifier models SGDH-60AE and SGDH-75AE require a regenerative unit (see "Component (E)" on page 80).

200V Three-phase Sigma II Servo Systems

Use the table below to select pre-wired cables for your SGMGH Sigma II gearmotor.

Pre-wired Cable Selection

SGMGH Gearmotors

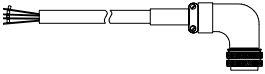
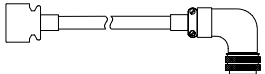
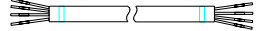
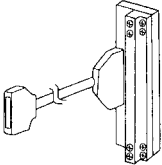
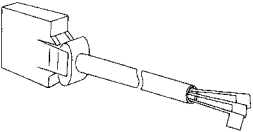
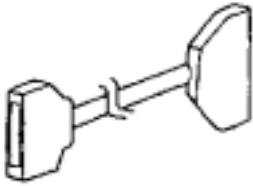
Cable Description (C)		Motor Size (kW)	Part Number*		Comments	Item Class
			without Brake	with Brake		
Power Cable with Connectors (IP67)		0.5, 0.9, 1.3	B1E-□□(A)	B1BE-□□(A)	Use the following key to specify needed cable length (last two digits of the part number): 03: 3m 05: 5m 10: 10m (standard) 15: 15m 20: 20m	
		2.0, 3.0	B2E-□□(A)	B2BE-□□(A)		
		4.4	B3E-□□(A)	B3BE-□□(A)		
		5.5, 7.5	B5E-□□(A)	B5E-□□(A) B7BCE-□□(A)**		
Encoder Cable (incremental or absolute)		All	JZSP-CMP02-□□(B)		Cables are available in five lengths. Use two digits in the part number's last place: 03: 3m 05: 5m 10: 10m (standard) 15: 15m 20: 20m	Stock***
Encoder Cable (for applications up to 20m) Only for Solder Connections			FR-RMCT-SB		These cables are available in any length. For example: to order one FR-RMCT-SB cable, 16m long, specify: quantity: 16 part no.: FR-RMCT-SB.	
Encoder Cable (for applications from >20 to <50m) Only for Solder Connections			UL20276-SB			
Input/Output 1CN Cable & Transition Terminal Block			JUSP-TA50P		35 mm DIN rail mountable; the cable length is 0.5m.	
Input/Output 1CN Cable with Pigtail Leads			JZSP-CKI01-□(A)		Use the following key to specify needed cable length (last digit of part number): 1: 1m (standard) 2: 2m 3: 3m	
Input/Output 1CN Cable Cable with Female D-Sub output Connector****			JZSP-CKI0D-□□		Use the following key to specify cable length (last two digits of the part number): D50: 0.5m 01: 1m (standard) 02: 2m 03: 3m	

* "(A)" at the end of the cable number indicates the revision level. The revision level may be changed prior to this catalog's reprinting.
 ** When ordering these cables for motors with brakes, order the standard B5E power cable and the additional cable for the brake.
 *** Standard cable lengths are Stock items; non-standard cable lengths are Limited Stock items.
 **** 50 Pin Female D-Sub output connector mates to customer supplied third party terminal block. (e.g., Wago #289-449, Weidmuller #919658, Phoenix #2283647, Amphenol/Sine #20-51039, and many others).

Connector Selection

Use the table below to select mating connectors for your SGMGH Sigma II gearmotor.

Connector Description (D)	Motor Size (kW)	Part Number		Comments	Item Class
		without Brake	with Brake		
MS Connector for Motor Power Cable *	0.5, 0.9, 1.3	MS3106B18-10S	MS3106B20-15S	Straight-type connector	Stock
		MS3108B18-10S	MS3108B20-15S	L-type connector	
		MS3057-10A	MS3057-12A	Cable clamp	
	2.0, 3.0, 4.4	MS3106B22-22S	MS3106B24-10S	Straight-type connector	
		MS3108B22-22S	MS3108B24-10S	L-type connector	
		MS3057-12A	MS3057-16A	Cable clamp	
	5.5, 7.5	MS3106B32-17S	MS3106B32-17S and MS3106A10SL-3S	Straight-type connector	
		MS3108B32-17S	MS3108B32-17S and MS3108A10SL-3S	L-type connector	
		MS3057-20A	MS3057-20A MS3057-4A	Cable clamp	
MS Connector for Encoder Cable (incremental or absolute encoder)		MS3106B20-29S		Straight-type connector	
		MS3108B20-29S		L-type connector	
		MS3057-12A		Cable clamp	
1CN Mating Connector		JZSP-CKI9		—	
2CN Encoder Mating Connector		JZSP-CMP9-1		—	
3CN Peripheral Mating Connector		YSC-1		—	
5CN Connector and 1m Cable with Pigtails		DE9404559		Can use 5CN for analog speed and torque monitor service checks.	

* Choose either a straight or L-type connector and the associated cable clamp for a complete assembly. For example, L-type connector MS3108B18-10S is compatible with cable clamp MS3057-10A.

SGMGH
Gearmotors

200V Three-phase Sigma II Servo Systems

Peripheral Device Selection

Use the table below to select peripheral devices for your SGMGH Sigma II gearmotor.

Component (E)	Part Number	Description	Item Class
Hand-held Digital Operator Panel	JUSP-OP02A-1 and JZSP-CMS00-1	Portable unit with 1m adapter cable for Sigma II	Stock
Software Interface Cable	YS-12	Pre-wired 2.0m cable with 9-pin connector	
Absolute Encoder Battery	JZSP-BA01 JZSP-BA01-1	3.6V, 1000mAh (Lithium Battery) For SGDH-60 and above (same as JZSP-BA01 with longer lead)	
SigmaWin+ Software	JZSP-WP0001	Minimum Recommended System Requirements Pentium 200 MHz, 64MB RAM, 200MB hard drive, CDROM Drive, RS-232 or RS-422 port, Screen resolution 800x600 w/ 256 colors, and Windows 95,98,NT4.0,2000,ME. (Windows XP planned)	
Regenerative Unit for 6.0kW amplifier (880W)	JUSP-RA04	These are general purpose regenerative units.*	
Regenerative Unit for 7.5, 11, and 15kW amplifiers (1760W)	JUSP-RA05	Order the Motion document: PI#99004 for setup instructions for this unit. Caution: Proper set-up is necessary to avoid equipment damage.	
DC Reactor (for suppressing harmonics in the power supply) [†]	For 200V: SGDH-05AE SGDH-08AE SGDH-10AE SGDH-15AE SGDH-20AE SGDH-30AE SGDH-50AE	X5061 X5060 X5059 X5068	

* For an alternate solution, specify the individual resistor part number RH500N25_OHMK in necessary series or parallel connection. Refer to the SGDH servo amplifier section of this catalog for additional specifications, and the *Sigma II Series Servo System User's Manual* (YEA-SIA-S800-32.2) for proper resistor sizing guidelines.

CE Pre-wired Cable Selection

Use the table below to select shielded pre-wired power cables for your SGMGH Sigma II gearmotor.

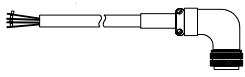
Cable Description (C)		Motor Size (kW)	Part Number*		Comments	Item Class
			without Brake	with Brake		
Power Cable with Connectors (IP67)		0.5, 0.9, 1.3	B1CE-□□(A)	B1BCE-□□(A)	Use the following key to specify needed cable length (last two digits of the part number): 03: 3m 05: 5m 10: 10m (standard) 15: 15m 20: 20m	Limited Stock
		2.0, 3.0	B2CE-□□(A)	B3BCE-□□(A)		
		4.4	B3CE-□□(A)			
		5.5, 7.5	B5CE-□□(A)	B7BCE-□□(A)		

* The "(A)" at the end of the cable number indicates the revision level. The revision level may be subject to change prior to this catalog's reprinting.

CE Connector Selection

Use the table below to select mating connectors for your SGMGH Sigma II gearmotor.

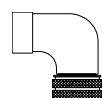
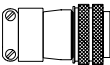
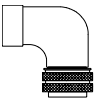
Connector Description (D)		Motor Size (kW)	Part Number		Comments**	Item Class
			without Brake	with Brake		
Connector for Motor Power Cable*		0.5, 0.9, 1.3	CE05-8A18-10SD-B-BAS	CE05-8A20-15SD-B-BAS	L-type connector	Limited Stock
			CE3057-10A-1(D265)	CE3057-12A-1(D265)	Cable clamp	
		2.0, 3.0, 4.4	CE05-8A22-22SD-B-BAS	CE05-8A24-10SD-B-BAS	L-type connector	
		5.5, 7.5	CE3057-12A-1(D265)	CE3057-16A-1(D265)	Cable clamp	
			CE05-8A32-17SD-B-BAS or CE05-6A32-17SD-B-BSS and CE3057-20A-1		L-type connector or Straight-type connector and Cable clamp (diameters 0.866 to 0.937in)	
Connector for Holding Brake		All	CE05-8A10SL-3SC-B-BAS and CE3057-4A-1 (D265)		L-type connector for holding brake and Cable clamp (diameters 0.142 to 0.220in)	
Connector for Encoder Cable (incremental or absolute encoder)			CE02-6A20-29NSW and CE20BA-S and CE3057-12A-3(D265)		L-type connector (plug and back shell) and Cable clamp (diameters 0.265 to 0.394in)	

* Choose the connector and the associated cable clamp for a complete assembly. The connectors listed in the table are suitable for IP67 environments.

** Connectors are manufactured by DDK and listed here with the largest standard cable clamp available.

NOTES:

Super High Power Rate Series **SGMSH Servomotors** - With Incremental / Absolute Encoder

Rated Output: 1.0kW, 1.5kW, 2.0kW,
3.0kW, 4.0kW, 5.0kW



For Additional Information	Page(s)
SGMSH Ratings & Specifications	86
SGMSH Speed/Torque Curves	87
SGMSH Dimensions	88 - 89
SGMSH Selection/Ordering Information	90 - 95
SGDH Ratings & Specifications	99 - 100
SGDH Dimensions	101 - 112

Design Features

1. Compact

- Small sized motor
- Six frame sizes: up to 422in • lb peak torque

2. High Speed

- Rated Speed: 3000rpm
- Maximum Speed: 5000rpm

3. Encoders

- 17-bit (32,768 ppr x 4) incremental encoder (standard)
- 17-bit absolute encoder (option)

4. Enclosure

- Totally enclosed, self-cooled IP67 (excluding shaft)
- IP67 with shaft seal (option)

5. Application Emphasis

- High torque to inertia ratio
- Chip mounters
- PCB drilling machines
- Robots
- Conveyors
- Packaging

6. Certified International Standards

- UL, cUL recognized (File #: E165827), CE compliance

Servomotor Ratings and Specifications

Time Rating:	Continuous	Enclosure:	Totally-enclosed, self-cooled	Maximum Rotational Speed:	5000rpm
Insulation:	Class F		IP67 (except for shaft opening)		
Vibration:	15 μ m or less	Ambient Temperature:	0 to 40°C	Excitation:	Permanent magnet
Withstand Voltage:	1500V _{ac}	Ambient Humidity:	20 to 80%	Drive Method:	Direct drive
Insulation Resistance:	10M Ω minimum at 500V _{DC}		(non-condensing)	Mounting:	Flange-mounted
		Rated Speed:	3000rpm	Painting Color:	Muncell notation N1.5

Amplifier System Voltage	MOTORS: SGM5H-	Rated Output*	Rated Torque*		Instantaneous Peak Torque*		Rated Current*	Instantaneous Maximum Current*
		kW (hp)	N · m	KG · cm (lb · in)	N · m	KG · cm (lb · in)	A _{rms}	A _{rms}
200V _{ac}	10A□A	1.0 (1.3)	3.18	32.4 (28.2)	9.54	97.2 (84.4)	5.7	17
	15A□A	1.5 (2.0)	4.9	50 (43.4)	14.7	150 (130)	9.7	28
	20A□A	2.0 (2.7)	6.36	65 (56.4)	19.1	195 (169)	12.7	42
	30A□A	3.0 (4.0)	9.8	100 (87)	29.4	300 (260)	18.8	56
	40A□A	4.0 (5.4)	12.6	129 (112)	37.8	387 (336)	25.4	77
	50A□A	5.0 (6.7)	15.8	161 (140)	47.6	486 (422)	28.6	84

MOTORS SGM5H-	Torque Constant	Moment of Inertia		Holding Brake (at 20°C)					Allowable Load Inertia	Rated Power Rate*	Rated Angular Acceleration*	Inertia Time Constant	Inductive Time Constant
				Capacity	Torque	Coil Resistance	Rated Current	Additional Inertia					
				W	N · m	Ω	A	lb _f · in · s ² · 10 ⁻³					
	$\frac{\text{lb}_f \cdot \text{in}}{\text{A}_{\text{rms}}}$ $\left(\frac{\text{N} \cdot \text{m}}{\text{A}_{\text{rms}}}\right)$	$\text{lb}_f \cdot \text{in} \cdot \text{s}^2 \cdot 10^{-3}$	$\text{KG} \cdot \text{m}^2 \cdot 10^{-4}$										
10A□A	5.6 (0.64)	1.54	1.74	7.0	7.84	82.0	0.29	0.289	8.7	57.9	18250	0.87	7.1
15A□A	5.0 (0.56)	2.19	2.47						12.4	97.2	19840	0.71	7.7
20A□A	4.8 (0.55)	2.82	3.19						16.0	127	19970	0.58	8.3
30A□A	5.1 (0.57)	6.20	7.00	9.85	20.0	58.5	0.41	1.89	35.0	137	14000	0.74	13.0
40A□A	4.9 (0.53)	8.50	9.60						48.0	166	13160	0.60	14.1
50A□A	5.4 (0.60)	10.9	12.3						61.5	202	12780	0.57	14.7

* These items and torque-speed characteristics quoted in combination with an SGD5H servo amplifier at an armature winding temperature of 20°C.

Note: These characteristics can be obtained when the following heat sinks (steel plates) are used for cooling purposes:

Type 10A□A to 20A□A: (11.81 × 11.81 × 0.47 (in)) (300 × 300 × 12 (mm))

Type 30A□A to 50A□A: (15.75 × 15.75 × 0.79 (in)) (400 × 400 × 20 (mm))

Speed / Torque Curves

200V

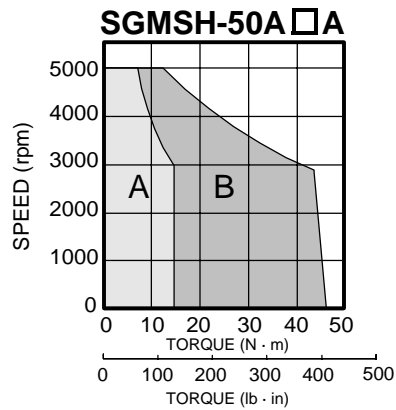
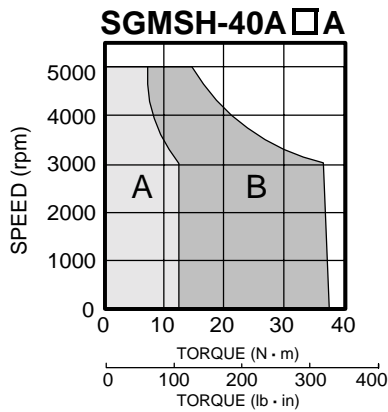
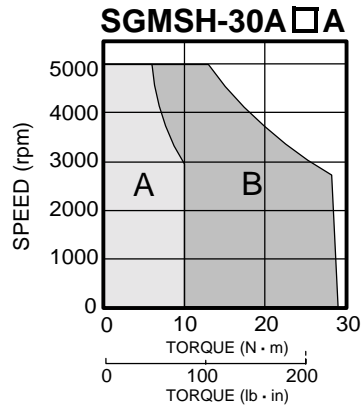
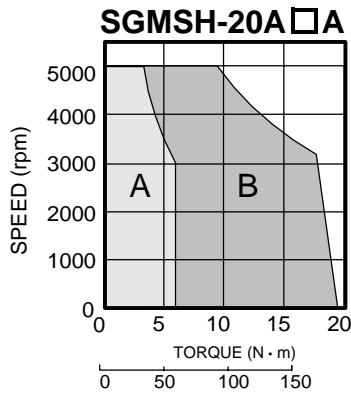
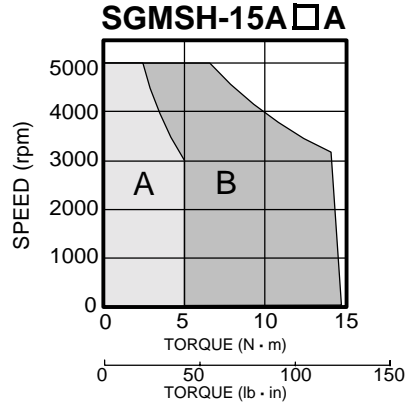
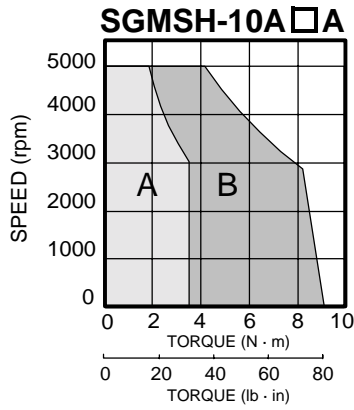

A : CONTINUOUS DUTY ZONE

B : INTERMITTENT DUTY ZONE

Dimensions in inches (mm)

(1) 17-bit Incremental or Absolute Encoder

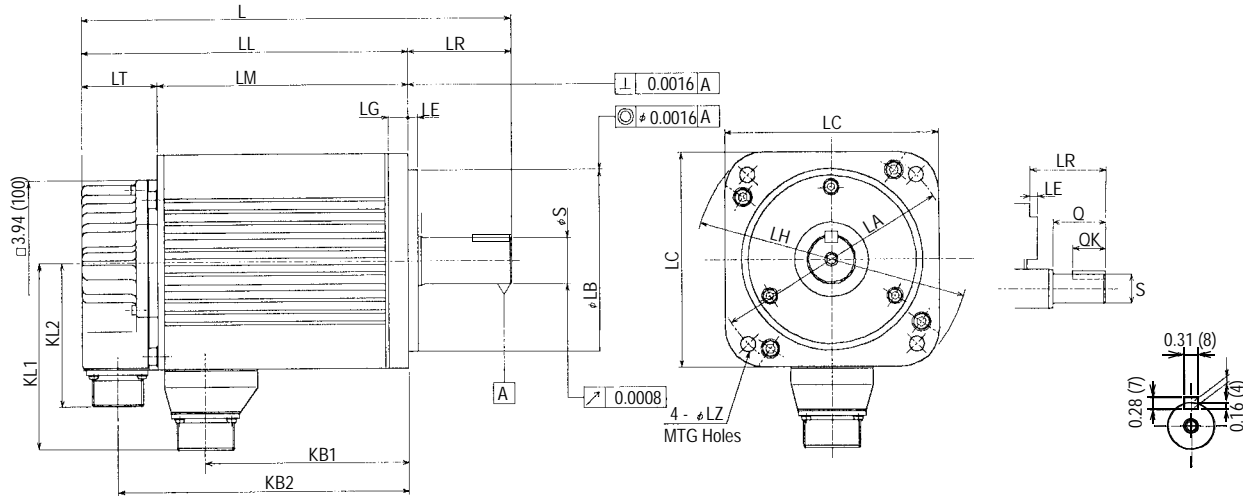

Type SGM SH-	L	LL	LM	LR	LT	KB1	KB2	KL1	KL2	Flange Dimensions				Shaft End Dimension			Approximate Mass lb _f (kg)	Allowable Radial Load lb _f (N)	Allowable Thrust Load lb _f (N)								
										ΦLA	ΦLB	LC	LE	LG	ΦLH	ΦLZ				ΦS	Q	OK					
10A□A61	7.64 (194)	5.87 (149)	4.06 (103)	1.77 (45)	1.81 (46)	2.99 (76)	5.04 (128)	3.78 (96)	3.43 (87)	4.53 (115)	3.74 (95)	3.94 (100)	0.12 (3)	0.39 (10)	5.12 (130)	0.28 (7)	0.94 (24)	1.57 (40)	1.26 (32)	10.1 (4.6)	154 (686)	44 (196)					
15A□A61	8.66 (220)	6.89 (175)	5.08 (129)			4.02 (102)	6.06 (154)			4.92 (125)	6.97 (177)	5.71 (145)	4.33 (110)	5.12 (130)	0.24 (6)	0.47 (12)	6.5 (165)	0.35 (9)	1.1 (28)	2.17 (55)			1.96 (50)	12.8 (5.8)			
20A□A61	9.57 (243)	7.8 (198)	5.98 (152)			4.8 (122)	7.01 (178)			6.26 (159)	8.46 (215)	7.83 (199)	10.04 (255)	8.46 (215)	7.83 (199)	10.04 (255)	4.49 (114)	3.43 (87)	5.71 (145)	4.33 (110)			5.12 (130)	0.24 (6)	0.47 (12)	6.5 (165)	0.35 (9)
30A□A61	10.31 (262)	7.83 (199)	6.02 (153)	4.8 (122)	7.01 (178)	6.26 (159)	8.46 (215)	7.83 (199)	10.04 (255)	4.49 (114)	3.43 (87)	5.71 (145)	4.33 (110)	5.12 (130)	0.24 (6)	0.47 (12)	6.5 (165)	0.35 (9)	1.1 (28)	2.17 (55)	1.96 (50)	24.3 (11)	220 (980)	30.9 (14)			
40A□A61	11.77 (299)	9.29 (236)	7.48 (190)	2.48 (63)	1.81 (46)	6.26 (159)	8.46 (215)	7.83 (199)	10.04 (255)	4.49 (114)	3.43 (87)	5.71 (145)	4.33 (110)	5.12 (130)	0.24 (6)	0.47 (12)	6.5 (165)	0.35 (9)	1.1 (28)	2.17 (55)	1.96 (50)	30.9 (14)	265 (1176)	88 (392)			
50A□A61	13.35 (339)	10.87 (276)	9.06 (230)	2.48 (63)	1.81 (46)	6.26 (159)	8.46 (215)	7.83 (199)	10.04 (255)	4.49 (114)	3.43 (87)	5.71 (145)	4.33 (110)	5.12 (130)	0.24 (6)	0.47 (12)	6.5 (165)	0.35 (9)	1.1 (28)	2.17 (55)	1.96 (50)	37.5 (17)	265 (1176)	88 (392)			

- Note: 1. Dimensions are the same when using either incremental or absolute encoders (with or without optional shaft seal).
2. Tolerances on the dimensions of flange type LB and shaft extensions S are based on JIS (Japanese Industrial Standard) B0401 "Limits and Fits for Engineering."

Specified Tolerances				
Dimension	*ΦS		**ΦLB	
Unit	Diameter	Tolerance	Diameter	Tolerance
in	0.9449, 1.1024	+0.0000-0.0005	3.7402, 4.3307	+0.0000 -0.0014
mm	24.000, 28.000	+0.000 -0.013	95.000, 110.000	+0.000 -0.035

Connector Wiring on the Incremental Encoders			
A	—	K	—
B	—	L	—
C	Data +	M	—
D	Data -	N	—
E	—	P	—
F	—	R	—
G	0V	S	Battery - (Note*)
H	+5V _{dc}	T	Battery + (Note*)
J	FG (Frame Ground)		*Note: Used with an absolute encoder only.

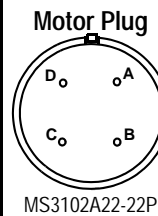
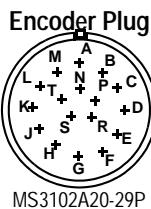

Connector Wiring on the Motor Side	
A	U Phase
B	V Phase
C	W Phase
D	Ground Terminal

Non-Environmental Mating Connector:
MS3108B20-29S (L Type)
MS3106B20-29S (Straight Type)
Cable Clamp: MS3057-12A

(2) 17-bit Incremental or Absolute Encoder, with Brake

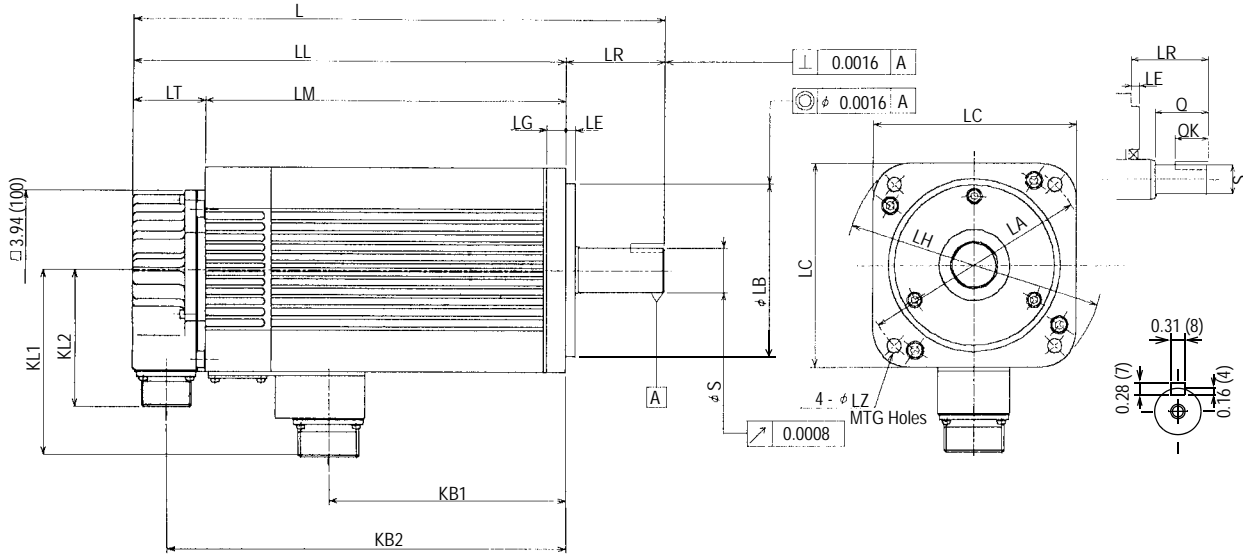

Type SGMSH-	L	LL	LM	LR	LT	KB1	KB2	KL1	KL2	Flange Dimensions						Shaft End Dimension			Approximate Mass lb _f (kg)	Allowable Radial Load lb _f (N)	Allowable Thrust Load lb _f (N)			
										ΦLA	ΦLB	LC	LE	LG	ΦLH	ΦLZ	ΦS	Q				QK		
10A□A6C	9.37 (238)	7.6 (193)	5.79 (147)	1.77 (45)	1.81 (46)	2.64 (67)	6.77 (172)	3.94 (100)	3.43 (87)	4.53 (115)	3.74 (95)	3.94 (100)	0.12 (3)	0.39 (10)	5.12 (130)	0.28 (7)	0.94 (24)	1.57 (40)	1.26 (32)	13.2 (6.0)	154 (686)	44 (196)		
15A□A6C	10.39 (264)	8.62 (219)	6.81 (173)	1.77 (45)		3.66 (93)	7.8 (198)			4.57 (116)	8.7 (221)	5.71 (145)	4.33 (110)	5.12 (130)	0.24 (6)	0.47 (12)	6.5 (165)	0.35 (9)	1.1 (28)	2.17 (55)			1.96 (50)	16.5 (7.5)
20A□A6C	11.3 (287)	9.53 (242)	7.72 (196)	1.77 (45)		4.45 (113)	8.5 (216)			5.91 (150)	9.96 (253)	4.33 (110)	5.12 (130)	0.24 (6)	0.47 (12)	6.5 (165)	0.35 (9)	1.1 (28)	2.17 (55)	1.96 (50)			18.7 (8.5)	
30A□A6C	11.81 (300)	9.33 (237)	7.52 (191)	2.48 (63)		4.45 (113)	8.5 (216)	5.91 (150)		9.96 (253)	4.69 (119)	5.71 (145)	4.33 (110)	5.12 (130)	0.24 (6)	0.47 (12)	6.5 (165)	0.35 (9)	1.1 (28)	2.17 (55)	1.96 (50)	30.9 (14)	220 (980)	88 (392)
40A□A6C	14.84 (377)	10.79 (274)	8.98 (228)	2.48 (63)		7.48 (190)	11.54 (293)	7.48 (190)		11.54 (293)	5.71 (145)	4.33 (110)	5.12 (130)	0.24 (6)	0.47 (12)	6.5 (165)	0.35 (9)	1.1 (28)	2.17 (55)	1.96 (50)	37.5 (17)	265 (1176)		
50A□A6C	12.36 (314)	10.55 (268)	7.48 (190)	2.48 (63)	7.48 (190)	11.54 (293)	7.48 (190)	11.54 (293)	5.71 (145)	4.33 (110)	5.12 (130)	0.24 (6)	0.47 (12)	6.5 (165)	0.35 (9)	1.1 (28)	2.17 (55)	1.96 (50)	44.1 (20)					

Note: 1. Dimensions are the same when using either incremental or absolute encoders (with or without optional shaft seal).
 2. Tolerances on the dimensions of flange type LB and of shaft extensions S are based on JIS (Japanese Industrial Standard) B0401 "Limits and Fits for Engineering."

Specified Tolerances					
Dimension	*ΦS		**ΦLB		
	Unit	Diameter	Tolerance	Diameter	Tolerance
	in	0.9449, 1.1024	+0.0000-0.0005	3.7402, 4.3307	+0.0000 -0.0014
	mm	24.000, 28.000	+0.000 -0.013	95.000, 110.000	+0.000 -0.035

Motor Plug

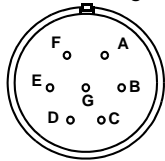

MS3102A20-15P

Connector Wiring on the Motor Side			
A	U Phase	E	Brake Terminal
B	V Phase	F	Brake Terminal
C	W Phase	G	—
D	FG (Frame Ground)		

Selecting Your SGM SH Sigma II Servo System

First, select the Sigma II servomotor suited for your application using SigmaSize: the Yaskawa servomotor sizing software, available at no charge. (Request SigmaSize software via e-mail, at: literature@yaskawa.com).

Use the diagram below to locate and identify the components of your system. Each item is letter-coded and cross-referenced in the option tables on the following pages.

System Configuration

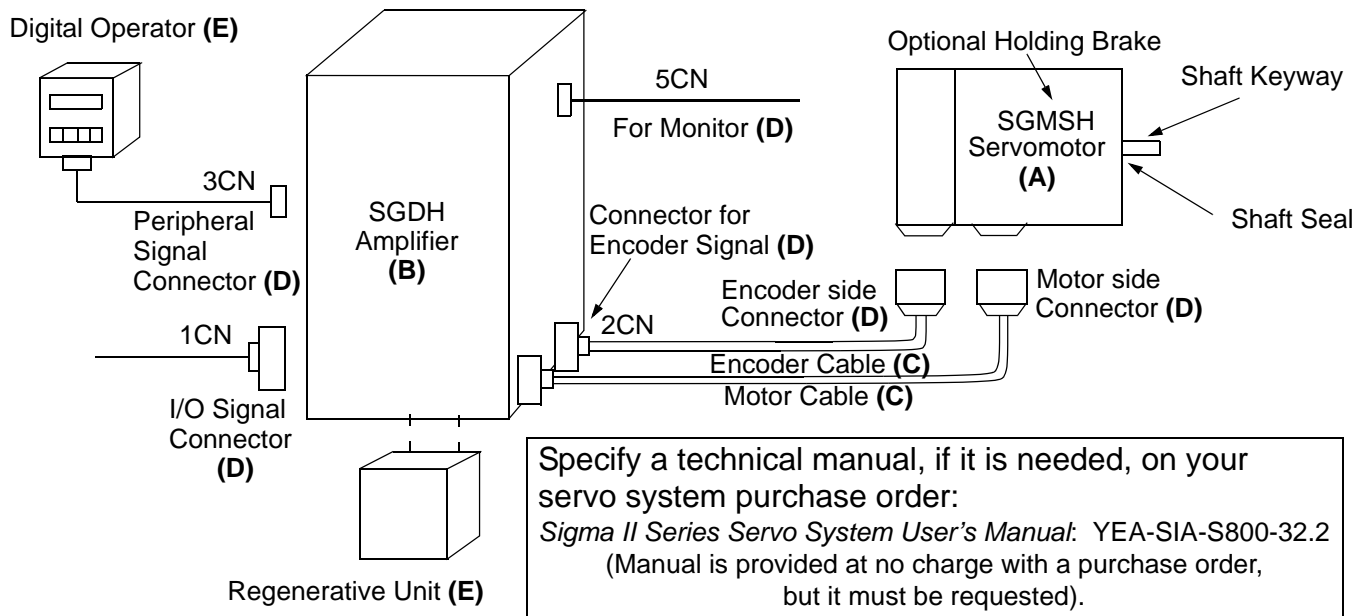

SGM SH Servomotors

Model Number Designation

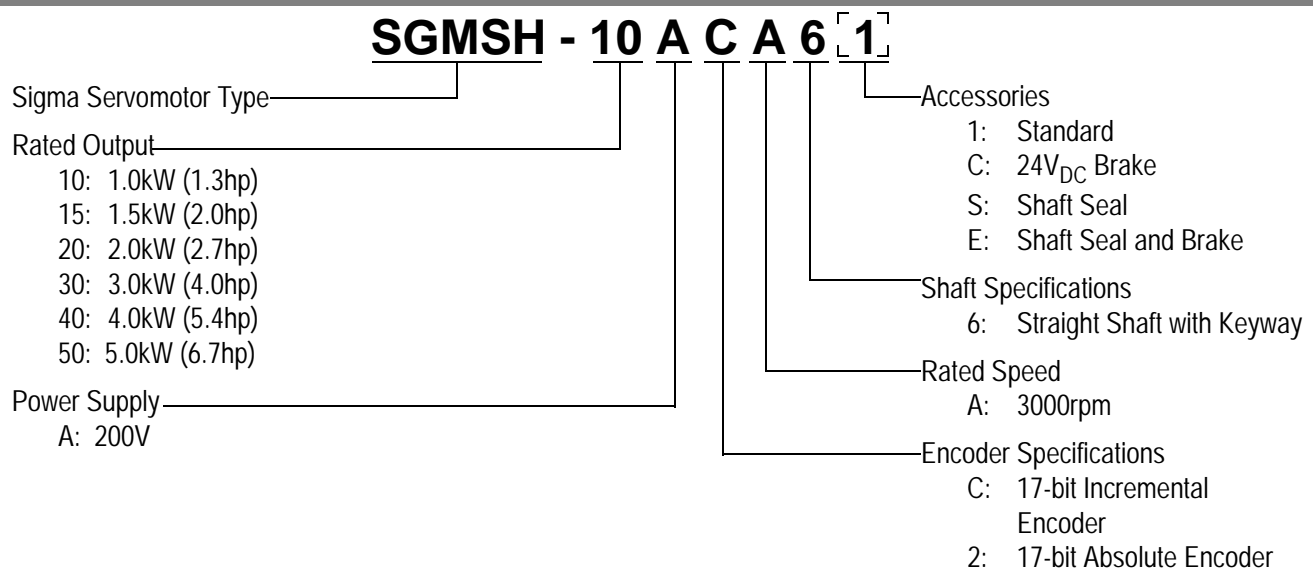

Servomotor & Amplifier Selection

Use the table below to select the appropriate SGMSH Sigma II servomotor and amplifier.
(Refer to the motor model # designation on the previous page specifying the available modification to motor construction/features.)

Description	Peak Torque (in • lb)	Rated Torque (in • lb)	Motor Inertia (in • lb • s ² X 10 ⁻³)	Motor MODEL # (A)	Amplifier MODEL # (B)* Analog/Digital Input SGDH-	Motor & Amplifier Item Class
200V, Three-Phase 17-bit Incremental Encoder Straight Shaft with Keyway 5000rpm maximum MS Connectors	84.4	28.2	1.54	SGMSH-10ACA61	10AE	Stock
			1.76	SGMSH-10ACA6C		
	130	43	2.19	SGMSH-15ACA61	15AE	
			2.41	SGMSH-15ACA6C		
	169	56.4	2.82	SGMSH-20ACA61	20AE	
			3.04	SGMSH-20ACA6C		
	260	87	6.2	SGMSH-30ACA61	30AE	
			8.1	SGMSH-30ACA6C		
	336	112	8.5	SGMSH-40ACA61	50AE	
			10.4	SGMSH-40ACA6C		
			10.9	SGMSH-50ACA61		
			12.8	SGMSH-50ACA6C		
422	140					

Note: 24V_{DC} brakes for SGMSH Sigma II servomotors are standard. Contact a local source for 24V_{DC} power supplies.
For technical information, request Yaskawa manual number YEA-SIA-S800-32.2.

* For more detailed SGDh amplifier specifications and dimensions, refer to pages 99 - 112.

Pre-wired Cable Selection

Use the table below to select pre-wired cables for your SGMSH Sigma II servomotor.

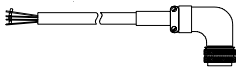
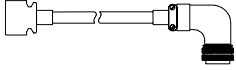
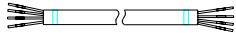
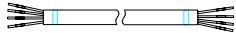
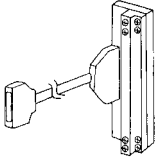
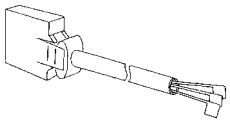
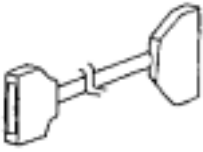
Cable Description (C)		Motor Size (kW)	Part Number*		Comments	Item Class
			without Brake	with Brake		
Power Cable with L-type Connectors (IP67)		1.0, 1.5, 2.0	B1E-□□(A)	B1BE-□□(A)	Use the following key to specify needed cable length (last two digits of the part number): 03: 3m 05: 5m 10: 10m (standard) 15: 15m 20: 20m	Stock**
		3.0	B2E-□□(A)	B2BE-□□(A)		
		4.0, 5.0	B3E-□□(A)	B3BE-□□(A)		
Encoder Cable (incremental or absolute) (IP67)		All	JZSP-CMP02-□□(B)		These cables are available in five lengths. Use two digits in the part number's last place: 03: 3m 05: 5m 10: 10m (standard) 15: 15m 20: 20m	
Encoder Cable (for applications up to 20m) Only for Solder Connections			FR-RMCT-SB		These cables are available in any length.	
Encoder Cable (for applications from >20 to <50m) Only for Solder Connections			UL20276-SB		For example, to order one FR-RMCT-SB cable, 16m long, specify: quantity: 16 part no.: FR-RMCT-SB	
Input/Output 1CN Cable & Transition Terminal Block			JUSP-TA50P		35mm DIN rail mountable; the cable length is 0.5m.	
Input/Output 1CN Cable with Pigtail Leads			JZSP-CKI01-□(A)**		Use the following key to specify required cable length (last digit of part number): 1: 1m (standard) 2: 2m 3: 3m	
Input/Output 1CN Cable with Female D-Sub output Connector***		JZSP-CKI0D-□□		Use the following key to specify cable length (last two digits of the part number): D50: 0.5m 01: 1m (standard) 02: 2m 03: 3m		

* "(A)" at the end of the cable number is the revision level. The revision level may be changed prior to this catalog's reprinting.

** Standard cable lengths are Stock items; non-standard cable lengths are Limited Stock items.

*** 50 Pin Female D-Sub output connector mates to customer supplied third party terminal block. (e.g., Wago #289-449, Weidmuller #919658, Phoenix #2283647, Amphenol/Sine #20-51039, and many others).

Connector Selection

Use the table below to select mating connectors for your SGMSH Sigma II servomotor.

Connector Description (D)	Motor Size (kW)	Part Number		Comments	Item Class
		without Brake	with Brake		
MS Connector for Motor Power Cable *	1.0, 1.5, 2.0	MS3106B18-10S	MS3106B20-15S	Straight-type connector	Stock
		MS3108B18-10S	MS3108B20-15S	L-type connector	
		MS3057-10A	MS3057-12A	Cable clamp	
	3.0, 4.0, 5.0	MS3106B22-22S	MS3106B24-10S	Straight-type connector	
		MS3108B22-22S	MS3108B24-10S	L-type connector	
		MS3057-12A	MS3057-16A	Cable clamp	
MS Connector for Encoder Cable (incremental or absolute encoder)	All	MS3106B20-29S		Straight-type connector	
		MS3108B20-29S		L-type connector	
1CN Mating Connector	All	MS3057-12A		Cable clamp	
		JZSP-CKI9		—	
2CN Encoder Mating Connector	All	JZSP-CMP9-1		—	
3CN Peripheral Mating Connector	All	YSC-1		—	
5CN Connector and 1m Cable with Pigtails	All	DE9404559		—	

* Choose either a straight or L-type connector and the associated cable clamp for a complete assembly.

Peripheral Device Selection

Use the table below to select peripheral devices for your SGMSH Sigma II servomotor.

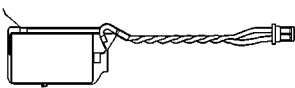
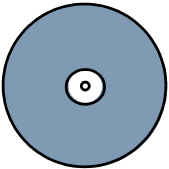
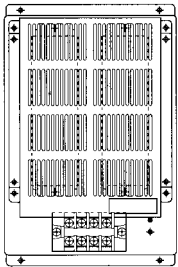
Component (E)	Part Number	Description	Item Class	
Hand-held Digital Operator Panel		JUSP-OP02A-1 and JZSP-CMS00-1	Portable unit with adapter cable for Sigma II	Stock
Absolute Encoder Battery		JZSP-BA01	3.6V, 1000mAh (lithium battery)	
SigmaWin+ Software		JZSP-WP0001	Minimum Recommended System Requirements Pentium 200 MHz, 64MB RAM, 200MB hard drive, CDROM Drive, RS-232 or RS-422 port, Screen resolution 800x600 w/ 256 colors, and Windows 95,98,NT4.0,2000,ME. (Windows XP planned)	
Software Interface Cable	—	YS-12	Pre-wired 2.0m cable with 9-pin connector	
External Regenerative Unit (Optional)		JUSP-RA04	These are general purpose regenerative units.* Order the Motion document: PI#99004 for setup instructions for this unit. Caution: Proper set-up is necessary to avoid equipment damage	
DC Reactor (for suppressing harmonics in the power supply)	SGDH-10AE	X5061	—	
	SGDH-15AE SGDH-20AE	X5060		
	SGDH-30AE SGDH-50AE	X5059 X5068		

* For an alternate solution, specify the individual resistor part number RH500N25_OHMK in necessary series or parallel connection. Refer to the SGDh servo amplifier section of this catalog for additional specifications, and the *Sigma II Series Servo System User's Manual* (YEA-SIA-S800-32.2) for proper resistor sizing guidelines.

CE Pre-wired Cable Selection

Use the table below to select shielded pre-wired cables for your SGMSH Sigma II servomotor. These are suitable for IP67 environments.

Use the standard encoder cable MS3057-12A listed on page 93.

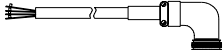
Cable Description (C)		Motor Size (kW)	Part Number*		Comments	Item Class
			without Brake	with Brake		
Power Cable with Connectors (IP67)		1.0, 1.5, 2.0	B1CE-□□(A)	B1BCE-□□(A)	Use the following key to specify required cable length (last digit of part number): 03: 3m 05: 5m 10: 10m (standard) 15: 15m 20: 20m	Limited Stock
		3.0	B2CE-□□(A)	B3BCE-□□(A)		
		4.0 5.0	B3CE-□□(A)			

* The "(A)" at the end of the cable number indicates the revision level. The revision level may be subject to change prior to this catalog's reprinting.

CE/IP67 Connector Selection

Use the table below to select mating connectors for your SGMSH Sigma II servomotor.

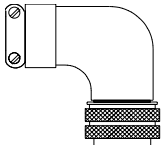
Connector Description (D)		Motor Size (kW)	Part Number*		Comments	Item Class
			without Brake	with Brake		
Connector for Motor Power Cable**		1.0, 1.5, 2.0	CE05-8A18-10SD-B-BAS CE3057-10A-1(D265)	CE05-8A20-15SD-B-BAS CE3057-12A-1(D265)	L-type connector Cable clamp	Limited Stock
		3.0, 4.0, 5.0	CE05-8A22-22SD-B-BAS CE3057-12A-1(D265)	CE05-8A24-10SD-B-BAS CE3057-16A-1(D265)	L-type connector Cable clamp	
Connector for Encoder Cable (incremental or absolute encoder)		All	CE02-6A20-29NSW and CE20BA-S CE3057-12A-3(D265)		L-type connector (plug and back shell) Cable clamp (for diameters 0.265 to 0.394in)	

* Connectors are manufactured by DDK and listed here with the largest standard cable clamp available.
** Choose the connector and the associated cable clamp for a complete assembly. The connectors listed in the table are suitable for IP67 environments.

NOTES:

SGDH Servo Amplifier - For Speed, Torque, & Position Control With Incremental or Absolute Encoder



Single-phase



Three-phase

For Additional Information	Page(s)
SGDH Ratings & Specifications	99 - 100
SGDH Dimensions	101 - 112
SGDH Internal Connections	113 - 114
Connection Diagram, Single Phase	115
Connection Diagram, Three Phase	116
Connector Terminal Block Unit	117
Terminal Block Pin Numbers	118
Amplifier/Encoder Connections	119
Cable Specs and Peripherals	121-125
SGMAH Sigma II Servo System	11 -28
SGMPH Sigma II Servo System	29 -46
SGMPH Gearmotor	47 -56
SGMGH Sigma II Servo System	57 -68
SGMGH Gearmotor	65 -84
SGMSH Sigma II Servo System	85 -96

Design Features

1. Improved Performance

- Higher bandwidth response (400Hz speed loop frequency response)
- Positioning settling time shortened to 1/2 to 1/3
- Smooth control at low rpm made possible by Sigma II servomotors' high resolution feedback

2. Easy Operation

- All-in-one model (speed, torque, and position control)
- PC monitoring function available including graphical tuning and file storage
- Adaptive-tuning function
 - Online auto-tuning
- Multi-axis communication provided as standard
 - One PC can communicate with up to 14 SGD units by parameter setting
- Built-in parameter setting device
- On-board storage of alarm history
- Automatic determination of motor settings at connection

3. Additional functionality with ready-to-install application modules

- Configurable single axis controls including serial networking capability
- Fieldbus connectivity (Devicenet™, Profibus™, etc.)
- Full closed loop (optional position feedback)
- Yaskawa MP940 single axis motion controller

4. Certified International Standards

- UL, cUL listed (File #: E147823), CE compliance

Model Number Designation

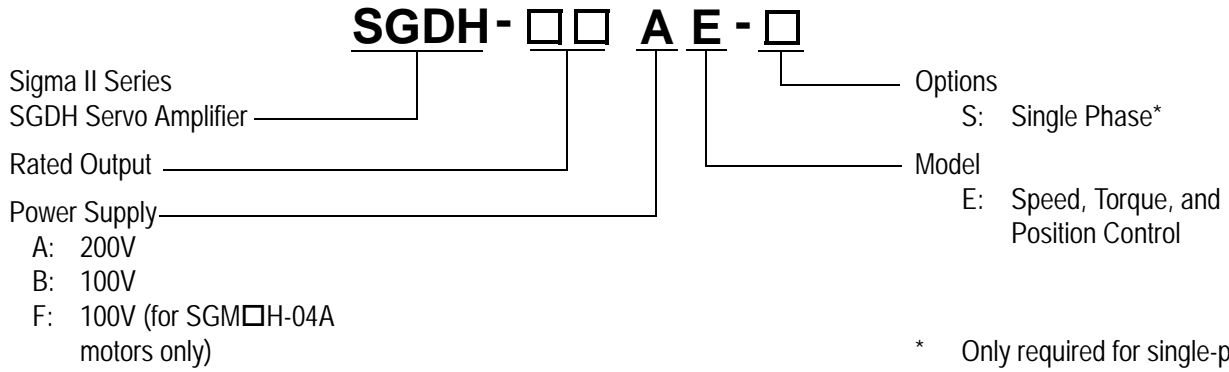

* Only required for single-phase sizes 08 and 15.

Amplifier Model	Capacity kW (HP)	AC Supply Phases
A3	0.03 (0.04)	1
A5	0.05 (0.07)	
01	0.10 (0.13)	
02	0.20 (0.27)	
04	0.40 (0.54)	
08	0.75 (1.0)	
15	1.5 (2.0)	
05	0.5 (6.7)	3
08	0.75 (1.0)	
10	1.0 (1.3)	
15	1.5 (2.0)	
20	2.0 (2.7)	
30	3.0 (4.0)	
50	5.0 (6.2)	
60	6.0 (8.0)	
75	7.5 (10)	
1A	11 (15)	
1E	15 (20)	

SGDH Amplifier Ratings and Specifications

Basic Specifications	Input Power Supply	Main Circuit*	Three-phase (or single-phase) 200 to 230V _{ac} +10% to -15%, 50/60 Hz, or single-phase 100 to 115V _{ac} +10% to -15%, 50/60 Hz	
		Control Circuit*	Single-phase 200 to 230V _{ac} (or 100 to 115V _{ac}) +10% to -15%, 50/60 Hz	
	Control Mode		Three-phase, full-wave rectification IGBT PWM (sinusoidal commutation)	
	Feedback		Serial incremental encoder, absolute encoder	
	Location	Ambient/Storage Temperature**		0 to 55°C / -20 to 85°C
		Ambient/Storage Humidity		90% or less (no-condensing)
		Vibration/Shock Resistance		4.9m/s ² /19.6m/s ²
Structure		Base mounted (duct ventilation available as option) and flat mount type		
Speed/Torque Control Mode	Performance	Speed Control Range		1 : 5000 (The lowest speed of the speed control range is the speed at which the servomotor will not stop with a rated torque load.)
		Speed Regulation***	Load Regulation	0% to 100%: 0.01% max. (at rated speed)
			Voltage Regulation	Rated voltage ±10% : 0% (at rated speed)
			Temperature Regulation	25 ± 25°C : 0.1% maximum (at rated speed)
		Frequency Characteristics		400Hz (at J _L = J _M)
	Accel/Decel Time Setting		0 to 10s (Can be set individually for acceleration and deceleration).	
	Input Signal	Speed Reference	Reference Voltage****	±6V _{DC} (variable setting range: ±2 to ±10V _{DC}) at rated speed (forward rotation with positive reference); input voltage: ±12V (maximum)
			Input Impedance	Approximately 14kΩ
			Circuit Time Constant	—
		Torque Reference	Reference Voltage****	±3V _{DC} (Variable setting range: ±1 to ±10V) at rated torque (forward rotation with positive reference), input voltage: ±12V _{DC} (maximum)
			Input Impedance	Approximately 14kΩ
			Circuit Time Constant	Approximately 47μs
		Contact Speed Reference	Rotation Direction Selection	Uses P control signal
	Speed Selection		Forward/reverse rotation current limit signals are used (1st to 3rd speed selection). When both signals are OFF, the motor stops or enters another control mode.	

Notes: * The power voltage must not exceed 230V +10% (253V). If it is likely that it will exceed this limit, use a step-down transformer. For types SGDh-08AE-S and SGDh-15AE-S, voltage is 200 to 230V + 10% -5%.

** Use the servo amplifier within the ambient temperature range. When enclosed, the temperatures inside the cabinet must not exceed the specified range.

*** Speed regulation is defined as follows:

$$\text{Speed regulation} = \frac{(\text{no-load motor speed} - \text{full-load motor speed})}{\text{rated motor speed}} \times 100\%$$

**** Forward is clockwise viewed from the non-load side of the servomotor, (counterclockwise viewed from the load and shaft end).

Ratings and Specifications (cont'd)

Positioning Control Mode	Performance	Bias Setting		0 to 450rpm (setting resolution: 1rpm)
		Feed-forward Compensation		0 to 100% (setting resolution: 1%)
		Position Complete Width Setting		0 to 250 reference units (setting resolution: 1 reference unit)
	Input Signal	Reference Signal	Type	Sign + pulse train, 90° phase difference 2-phase pulse (phase A + phase B), or CCW + CW pulse train
			Pulse Buffer	Line driver (+5V level), open collector (+5V or +12V level)
Pulse Frequency			Maximum 500/200kpps (line driver/open collector)	
Control Signal		CLEAR (input pulse form identical to reference pulse)		
Built-in Open Collector Power Supply *		+12V (With built-in 1kW resistor)		
I/O Signals	Position Output	Output Form	Phases A, B and C: Line driver output Phase S: Line driver output (Only when absolute encoder is used)	
		Frequency Dividing Ratio	Any	
	Sequence Input		Servo ON, P control (or forward/reverse rotation in contact input speed control mode), forward rotation prohibited (P-OT), reverse rotation prohibited (N-OT), alarm reset, forward rotation current limit, and reverse rotation current limit (or contact input speed control)	
	Sequence Output	—	Servo alarm, 3-bit alarm codes	
Configurable: (Any 3 of these signals)		Positioning complete (speed coincidence), servomotor rotating, servo ready, current limit, brake release, warning, and near position signals		
Built-in Functions	Dynamic Brake (DB)		Activated at main power OFF, servo alarm, servo OFF or overtravel	
	Regenerative Processing		Incorporated. For 60 to 1A types, external regenerative resistor must be mounted.	
	Overtravel (OT) Prevention		Motor decelerates or coasts to a stop, or is stopped by a dynamic brake.	
	Protection		Overcurrent, overload, regenerative error, main circuit voltage error, heat sink overheat, power open phase, overflow, overspeed, encoder error, encoder disconnected, overrun, CPU error, parameter error.	
	LED Display		POWER, CHARGE, five 7-segment LEDs (built-in digital operator functions)	
	Analog Monitor (5CN)		Built-in analog monitor connector to observe speed, torque, and other reference signals Speed:1V/1000rpm Torque:1V/rated torque Pulses remaining:0.05V/reference units or 0.05V/100 reference units	
	Communication	Interface		Digital operator (mount type or hand-held) RS422A port such as person computer (RS-232C port can be used if some conditions are met).
		1 : N Communication		N can be up to 14 when RS-422A port is used.
		Axis Address Setting		Set via user parameters
Functions		Status display, user constant setting, monitor display, alarm traceback display, jogging, autotuning, speed/torque reference signals, other graphing functions, etc.		
Others		Reverse rotation connection, home position search, automatic servomotor ID, DC reactor connection terminal for high power supply frequency control.		

Note: * The built-in open collector power supply is not electrically isolated from the control circuit in the servo amplifier.

Dimensions in inches (mm)

SGDH Servo Amplifier (Standard)

- **SGDH-A3AE to -02AE (200V Single-phase, 30 to 200W) and**
- **SGDH-A3BE to -01BE (100V Single-phase, 30 to 100W)**

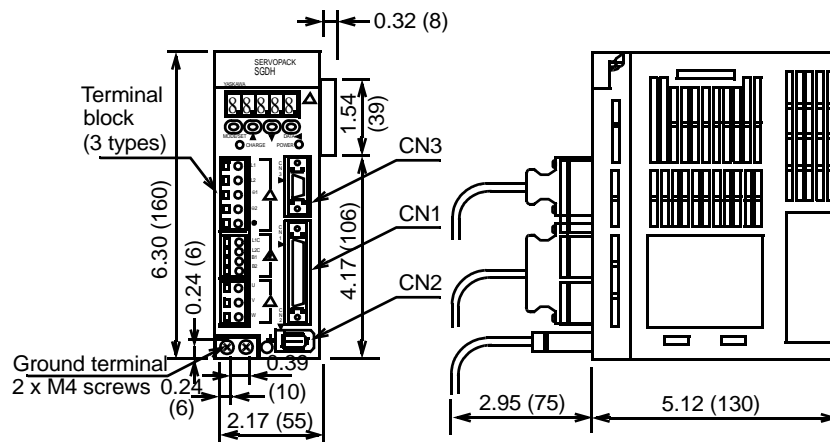

Mounting Hole Diagram

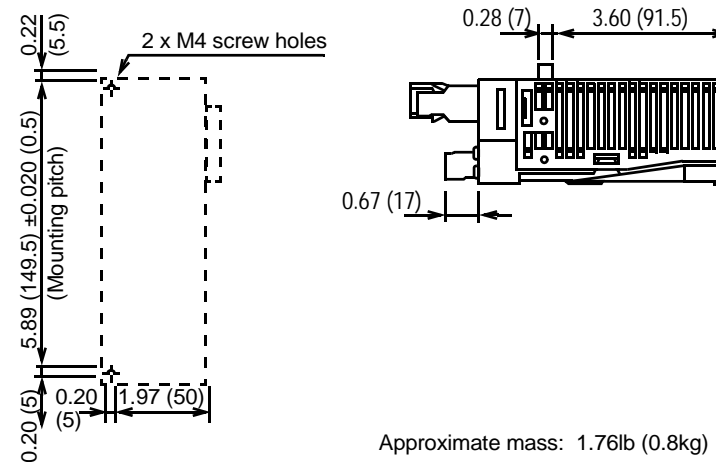

Approximate mass: 1.76lb (0.8kg)

Connectors on the amplifier (supplied):

Connector Symbol	Servo Amplifier Receptacle	Manufacturer
CN1	10250-52A2JL	3M Company
CN2	53460-0611	Molex Co.
CN3	10214-52A2JL	3M Company

User needs to obtain the following:

Connector Symbol	Mating Connector	Manufacturer
1CN	10150-3000VE connector 10350-52A0-008 case	3M Company
2CN	55100-0600	Molex Co.
3CN	JEZ-9S connector J-C9-2C case	JST Company

100/200V Sigma II Servo System

- SGDH-04AE (200V Single-phase, 400W) and
- SGDH-02BE (100V Single-phase, 200W) and
- SGDH-04FE (100V Single-phase, 400W)

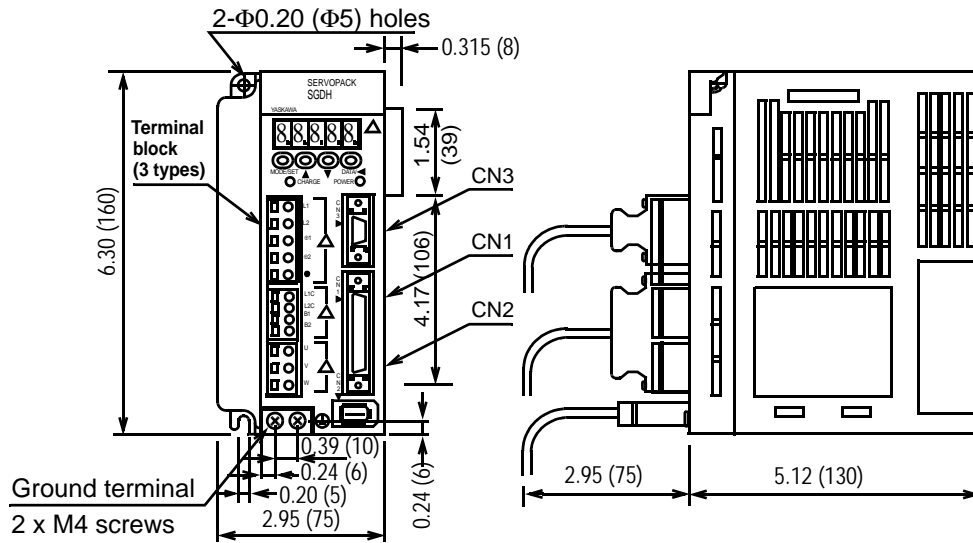

Mounting Hole Diagram

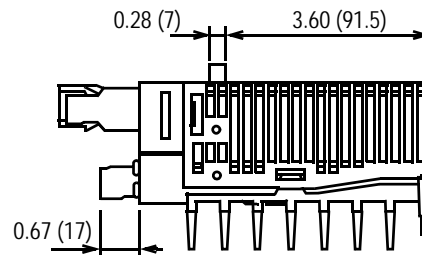
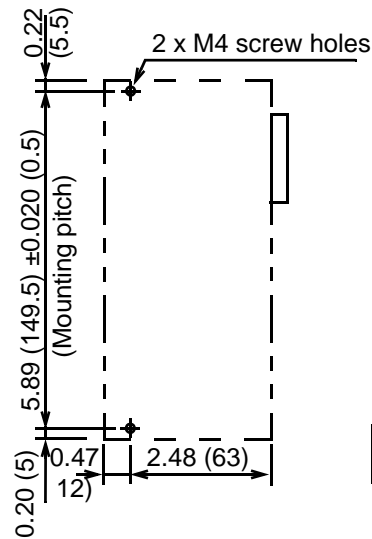

Mating connectors: [See page 99](#)

Approximate mass: 2.43lb (1.1kg)

100/200V Sigma II Servo Systems

- SGDH-05AE to 10AE (200V Three-phase, 0.5 to 1.0kW)
- SGDH-08AE-S (200V* Single-phase, 750W)

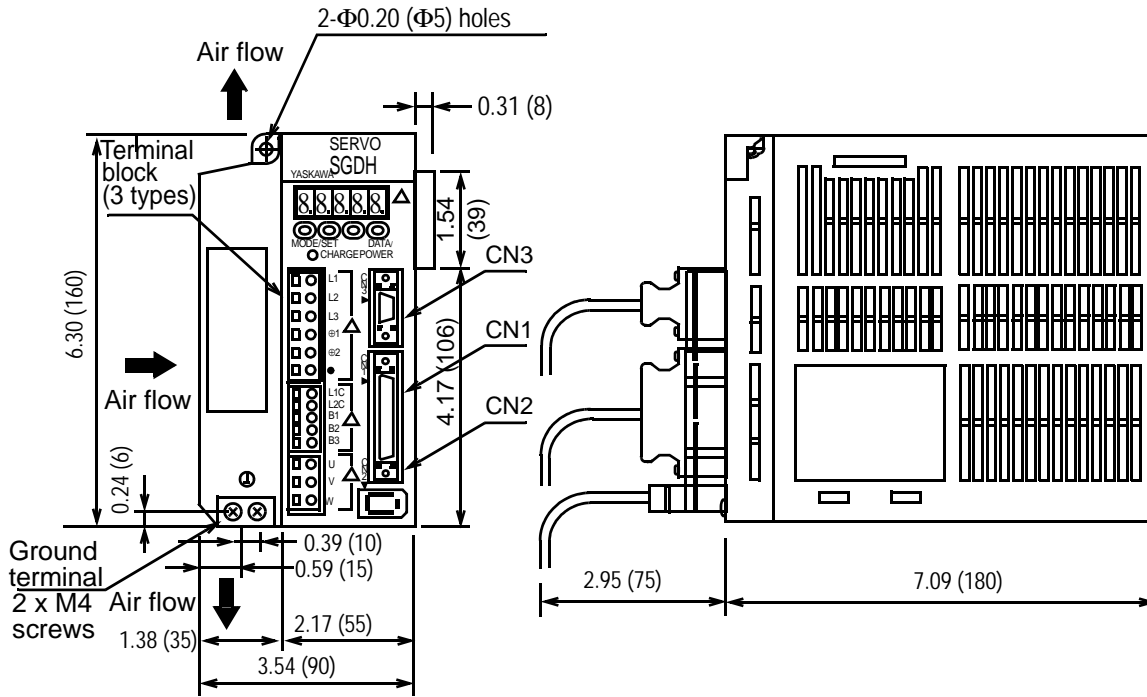

Mounting Hole Diagram

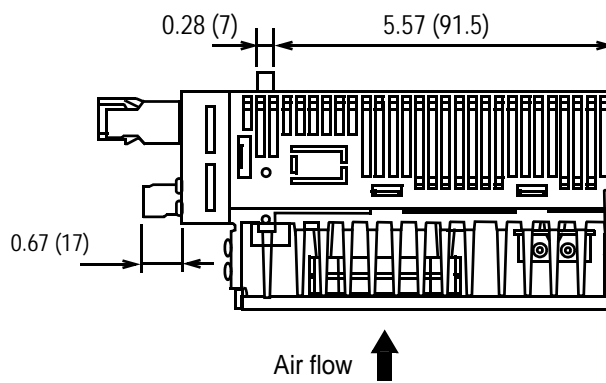
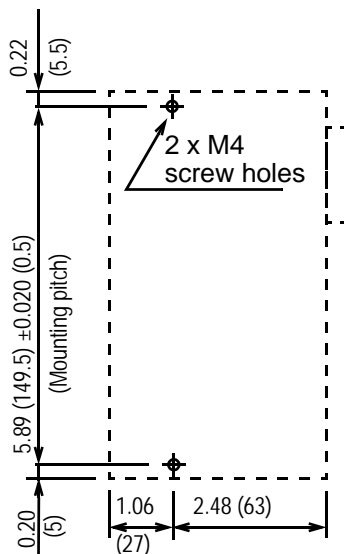

Approximate mass: 3.75lb (1.7kg)

Mating connectors: [See page 99](#)

* Rating 200 to 230V_{ac} +10% -5%

100/200V Sigma II Servo System

- **SGDH-15AE (200V Three-phase, 1.5kW)**

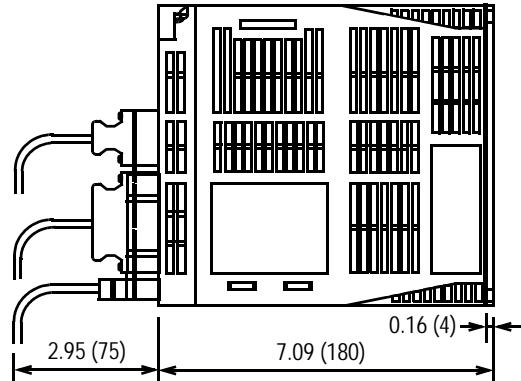
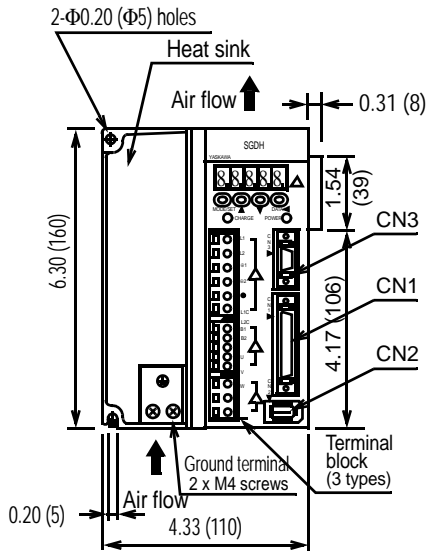

Mounting Hole Diagram

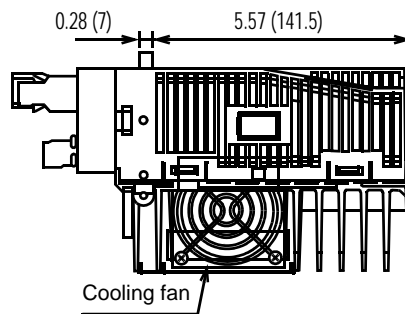
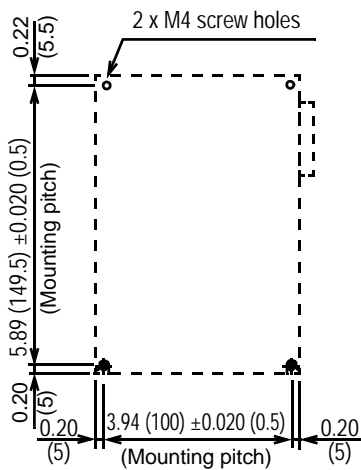

Approximate mass: 6.17lb (2.8kg)

Mating connectors: [See page 99](#)

100/200V Sigma II Servo Systems

- SGDH-20AE, 30AE (200V Three-phase, 2.0kW, 3.0kW)
- SGDH-15AE-S (200V Single-phase, 1.5 kW)*

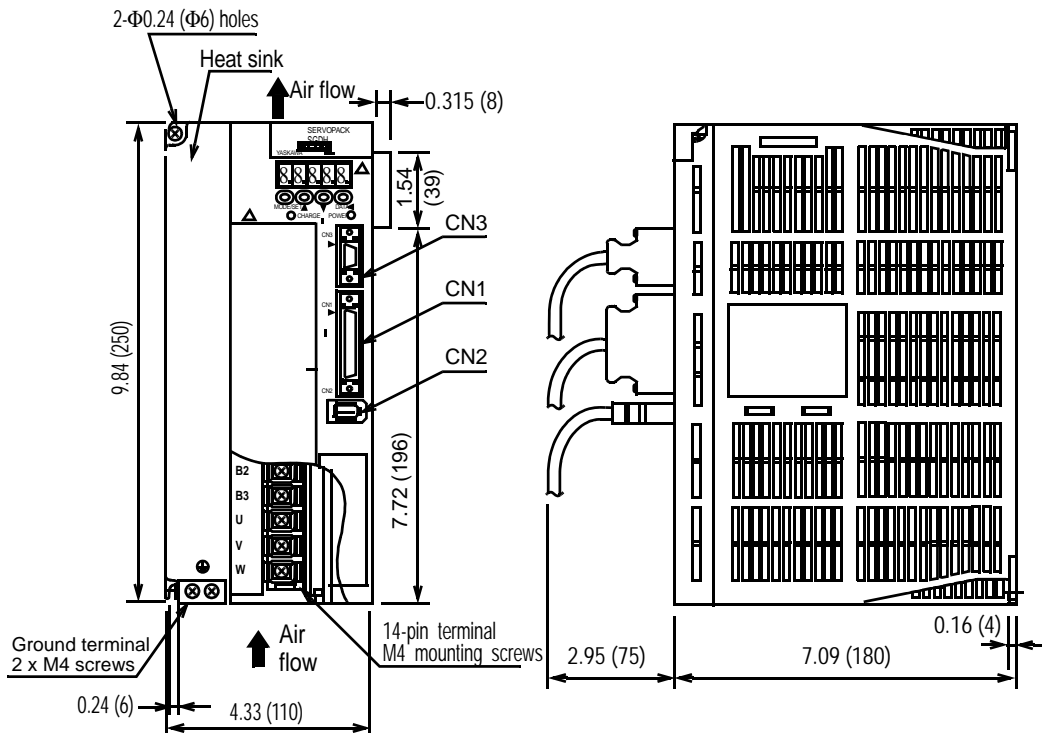

Mounting Hole Diagram

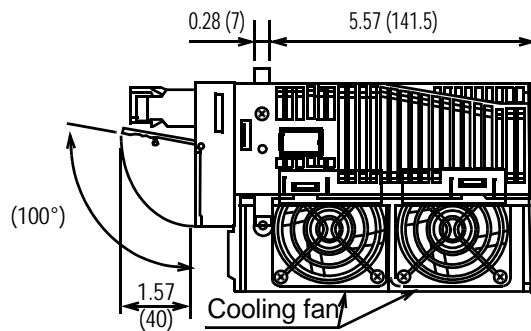
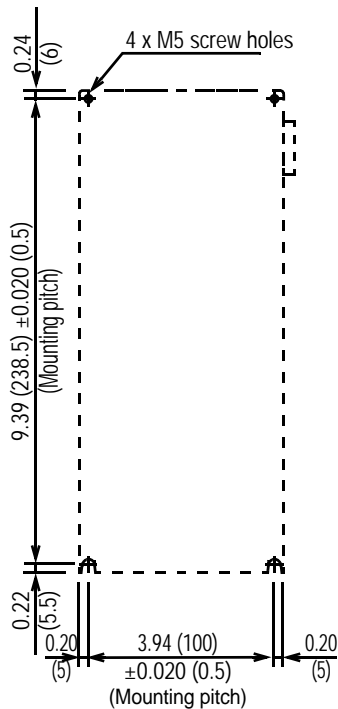

Approximate mass: 8.38lb (3.8kg)

Mating connectors: [See page 99](#)

* Rating: 200 to 230V_{ac} +10%, -5%

100/200V Sigma II Servo System

- **SGDH-50AE (200V Three-phase, 5.0kW)**

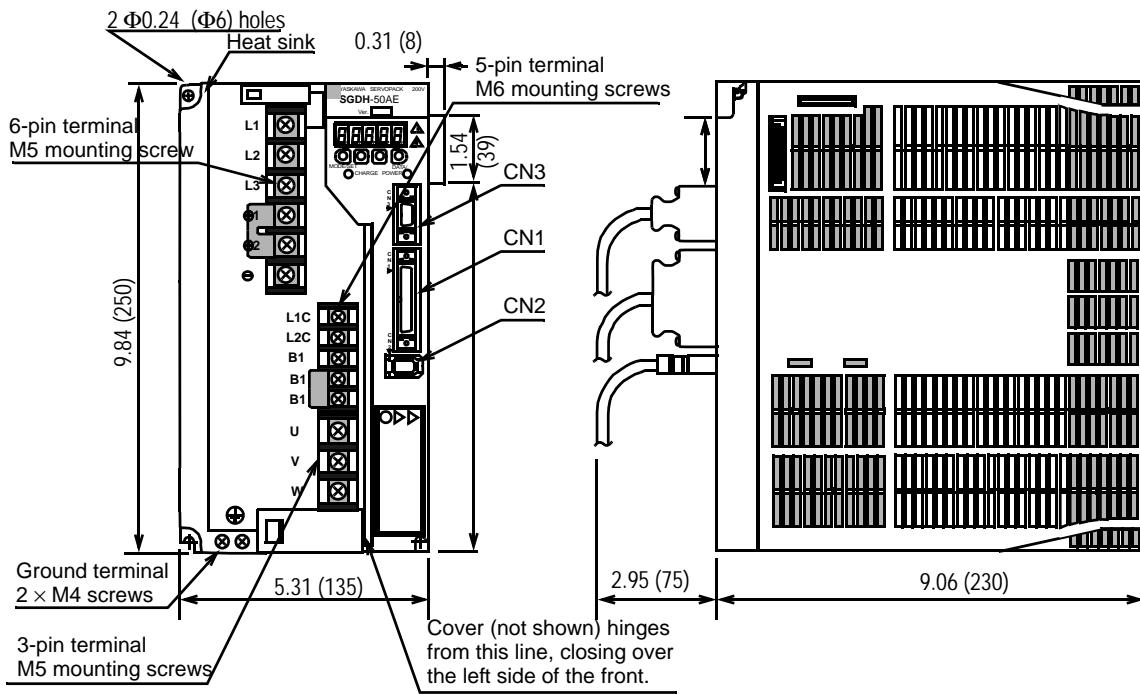

Mounting Hole Diagram

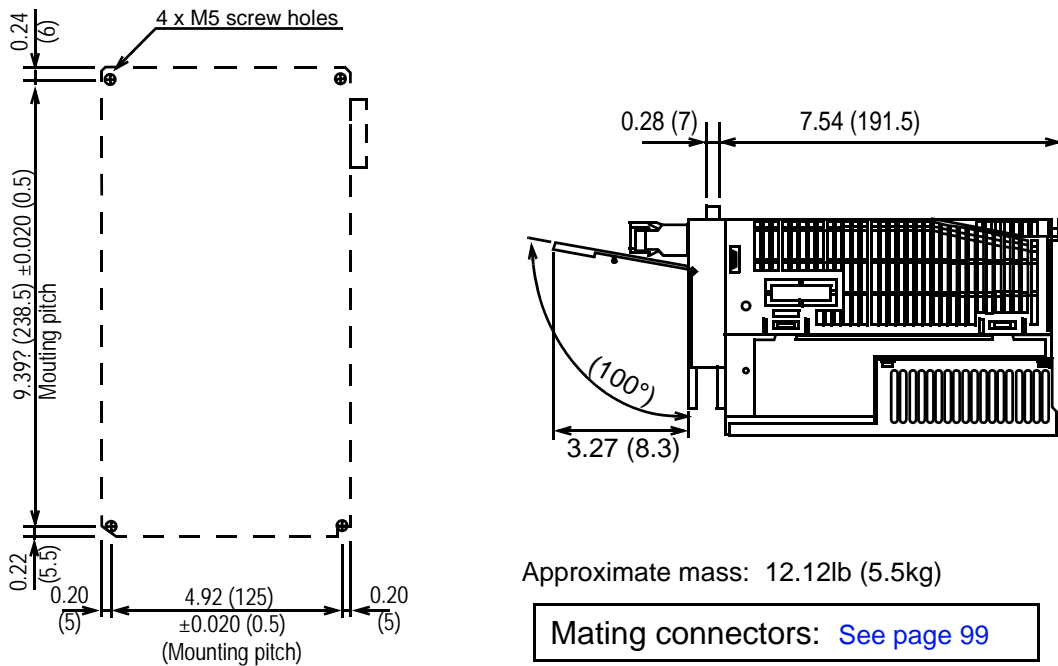

100/200V Sigma II Servo Systems

- SGDH-60AE, SGDH-75AE (200V Three-phase, 6.0kW, 7.5kW)

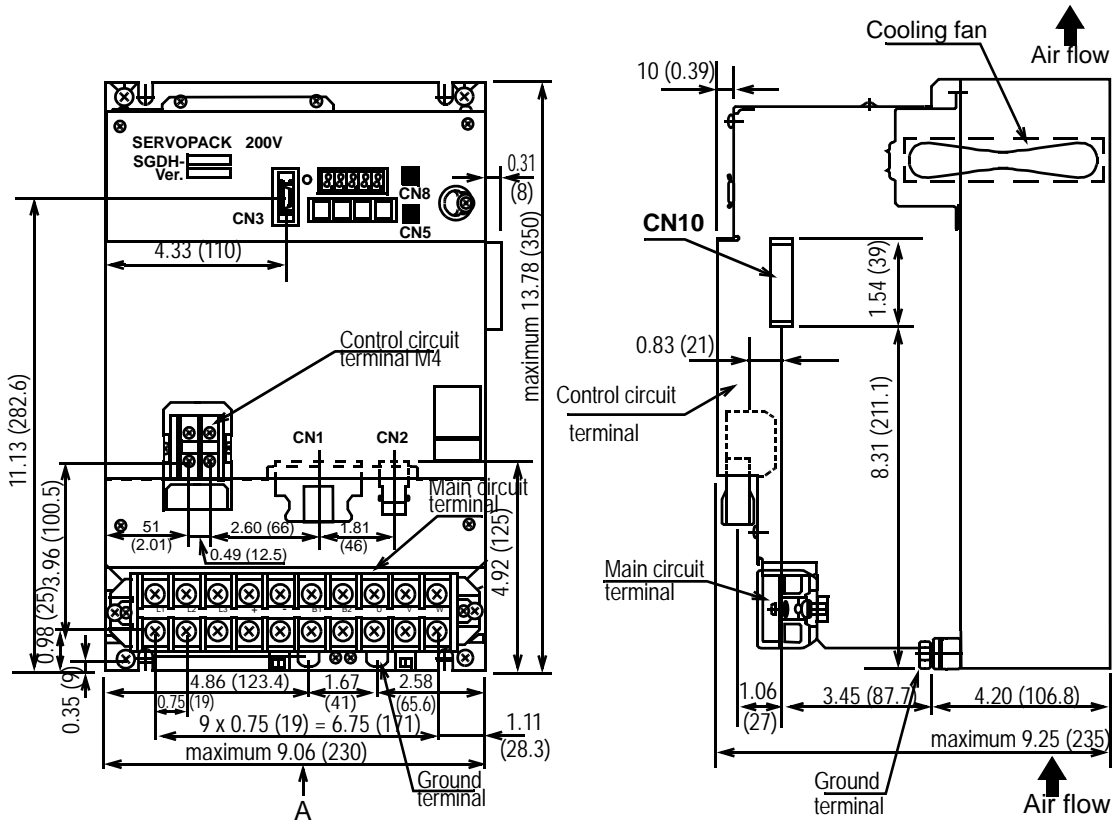

Mounting Hole Diagram

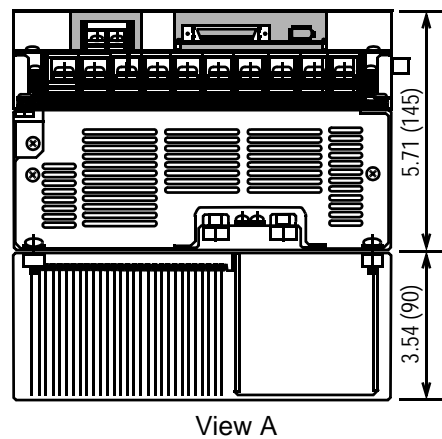
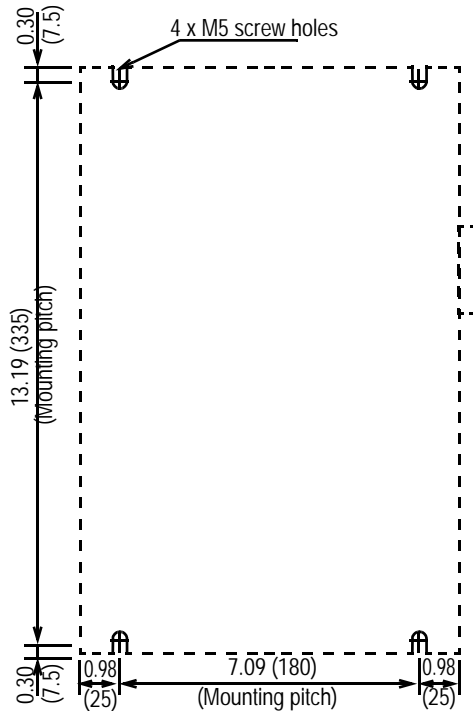

View A

Approximate Mass: 31.5lb (14.3kg)

Mating connectors: [See page 99](#)

100/200V Sigma II Servo System

- **SGDH-1AAE, SGDH-1EAE (200V Three-phase, 11.0kW, 15.0kW)**

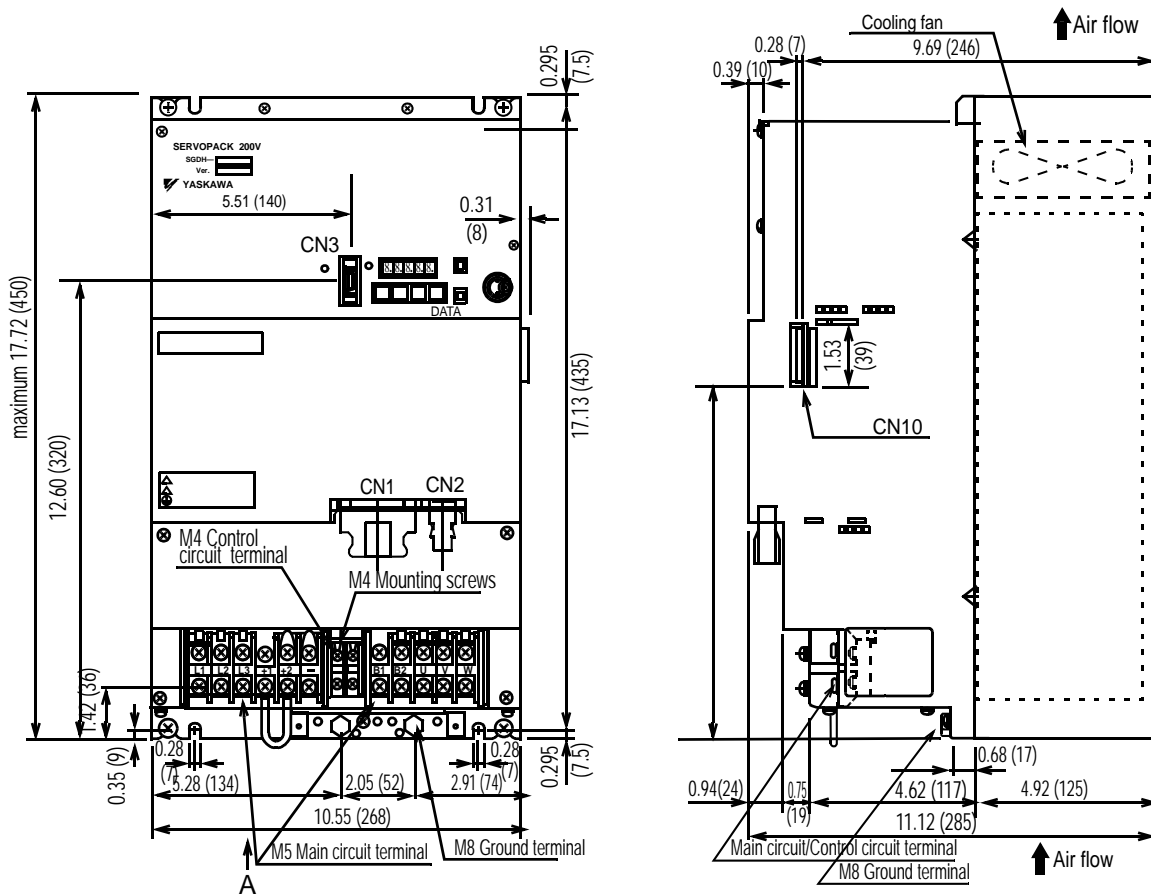

Mounting Hole Diagram

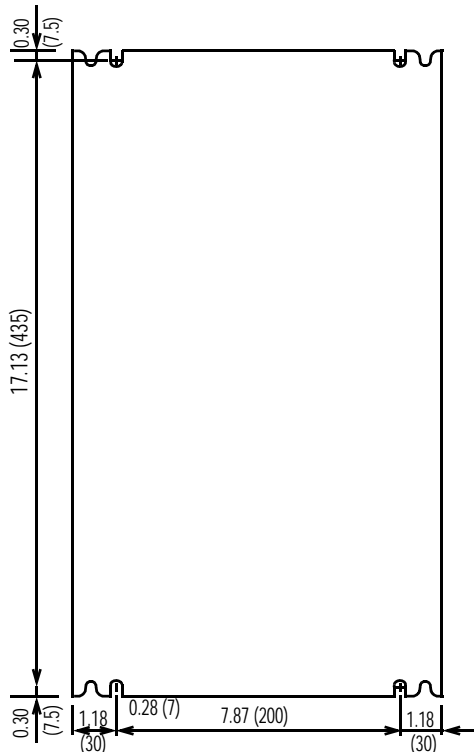

View A:

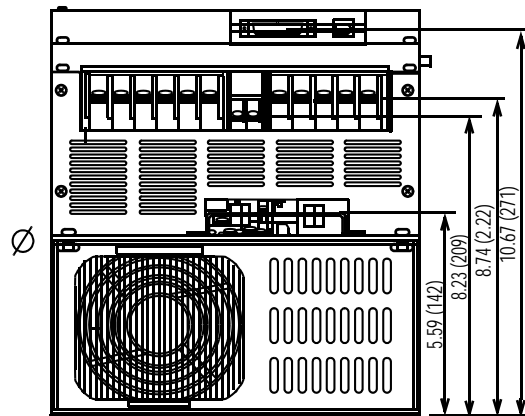

Approximate mass: 31.53lb (14.3kg)

Mating connectors: [See page 99](#)

Regenerative Resistor Units (JUSP-RA□□)

• Type JUSP-RA04

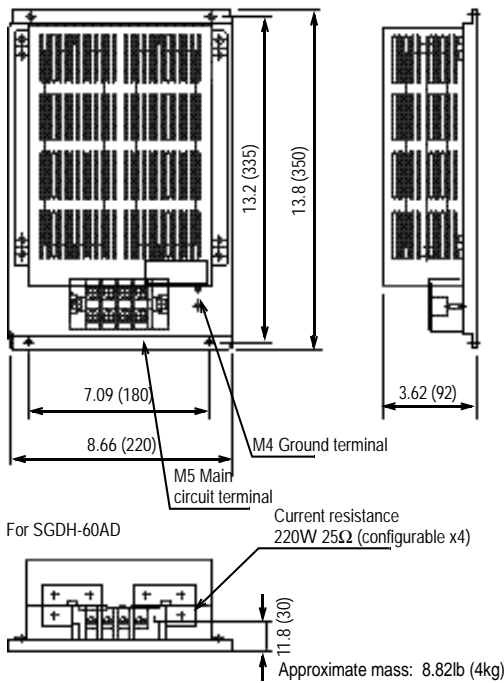

• Type JUSP-RA05

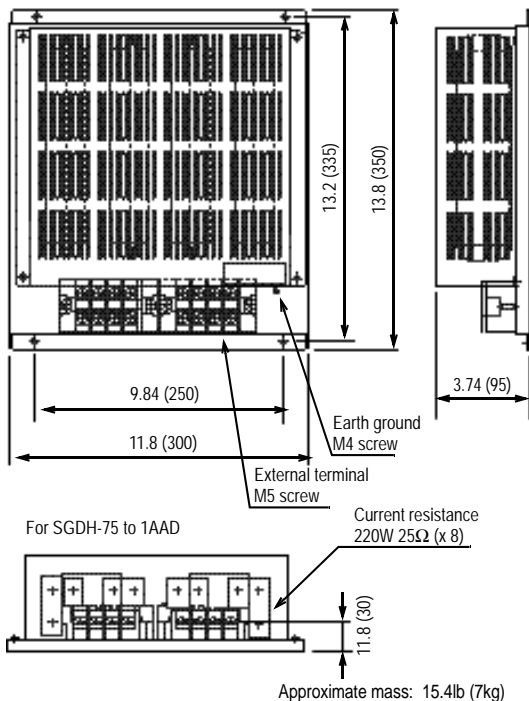

External Regenerative Resistors

Regenerative resistors for servo amplifiers are internally or externally mounted, as shown in the following table. They can be mounted externally on all servo amplifiers, but are especially effective when regenerative energy exceeds the servo amplifier's capacity.

When mounted externally, be sure to remove the jumper between B2 and B3, which deactivates the internal regenerative resistor.

Important: External regeneration resistor sizing and amplifier set-up will be important for proper operation.

Use Yaskawa's SigmaSize and the *Sigma II Series Servo System User's Manual: YEA-SIA-S800-32.2*

Applicable Servo Amplifier	Regenerative Resistor Mounted in a Servo Amplifier		Internal Regeneration Power Capacity (W)	Minimum Allowable Resistance (Ω)	
	Resistance (Ω)	Wattage* (W)			
200V Single-phase	SGDH-A3AE	—	—	40	
	SGDH-A5AE				
	SGDH-01AE				
	SGDH-02AE				
	SGDH-04AE				
	SGDH-08AE-S				
200V Three-phase	SGDH-15AE-S	50	60	12	20
	SGDH-05AE	50	60	12	40
	SGDH-08AE				
	SGDH-10AE				
	SGDH-15AE	30	70	14	20
	SGDH-20AE	25	140	28	12
	SGDH-30AE	12.5			
	SGDH-50AE	8	280	56	8
	SGDH-60AE	6.25**	880**	180	5.8
	SGDH-75AE	3.13***	1760***	350	2.9
	SGDH-1AAE				
	SGDH-1EAE				
100V Single-phase	SGDH-A3BE	—	—	40	
	SGDH-A5BE				
	SGDH-01BE				
	SGDH-02BE				

* Capacity prior to derating. If regeneration power requirements exceed internal capacity of the amp, install an external regeneration resistor (reference "Minimum Allowable Resistance". Be sure to derate wattage of external resistor to 20% or less (natural convection) and to 50% or less with forced air cooling.

** Provided externally by JUSP-RA04

*** Provided externally by JUSP-RA05

Single Regeneration Resistance Units

Consult the Design and Maintenance section of the Sigma II Series SGM□H/SGDH User's Manual (No. YEA-SIA-S800-32.2) for a more detailed description of the selection procedure.

Part#RH500N25_OHMK

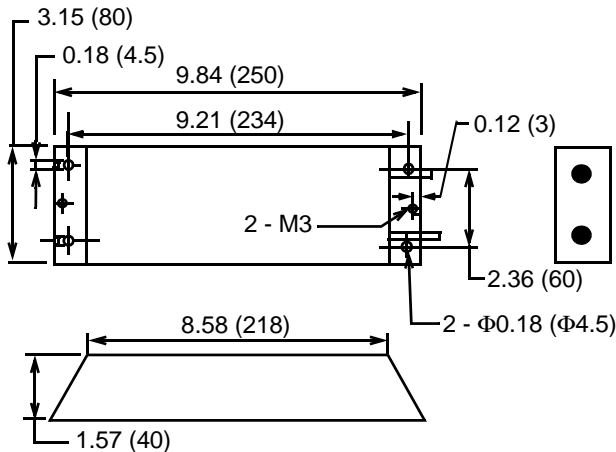

Lead wire:L = 17.72 (450)
 Rated power:300W
 Resistance value:25Ω

Part#RH120 50 OHMJ

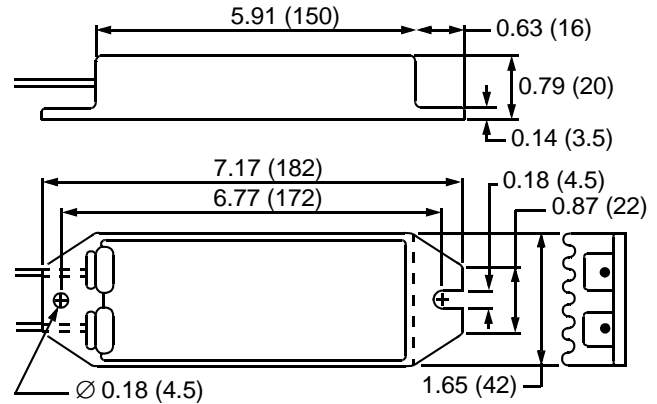

Lead wire:L = 11.81 (300)
 Rated power:70W
 Resistance value:50Ω

• Regenerative Resistor Specifications

Tolerance	J: ±7%, K: ±10%
Temperature Characteristics	±260PPM/°C (20Ω or higher)
Withstand Voltage	ΔR at 2000V _{ac} applied for one minute: ±(0.1% + 0.05Ω)
Insulation Resistance	20MΩ or higher at 500VDC
Short-term Overload	ΔR with ten times the rated power applied for five seconds (±2% + 0.05Ω)
Service Life	ΔR in 1000 hours at rated power 90 minutes ON and 30 minutes OFF (±5% + 0.05Ω)
Inflammability	Fire does not occur with 10 times the rated power applied for one minute.
Ambient Temperature Range	-25 to 150°C

Control of Harmonic Frequency in the Power Supply Circuit

If harmonic frequency control is needed in the power supply, connect a DC reactor between terminals (+) 1 and (+) 2 on the servo amplifier's main circuit. Use the following table as a guide for selection of the appropriate reactor.

Applicable Servo Amplifier		Reactor Specifications		Reactor Model
		Impedance (mH)	Rated Current (A)	
100V	SGDH-A3BE	—	—	—
	SGDH-A5BE	—	—	—
	SGDH-01BE	10.0	1.8	X5063
	SGDH-02BE	4.7	3.5	X5062
200V	SGDH-A3AE	—	—	—
	SGDH-A5AE	—	—	—
	SGDH-01AE	40.0	0.85	X5071
	SGDH-02AE	20.0	1.65	X5070
	SGDH-04AE	10.0	3.3	X5069
	SGDH-08AE-S	4.0	5.3	X5079
	SGDH-15AE-S	2.5	10.5	X5078
	SGDH-05AE	2.0	4.8	X5061
	SGDH-08AE			
	SGDH-10AE			
	SGDH-15AE	1.5	8.8	X5060
	SGDH-20AE	1.0	14.0	X5059
	SGDH-30AE			
	SGDH-50AE			
Larger size amplifiers	—	—	Consult factory for availability	

100/200V Sigma II Servo System

- DC Reactor Dimensional Drawings

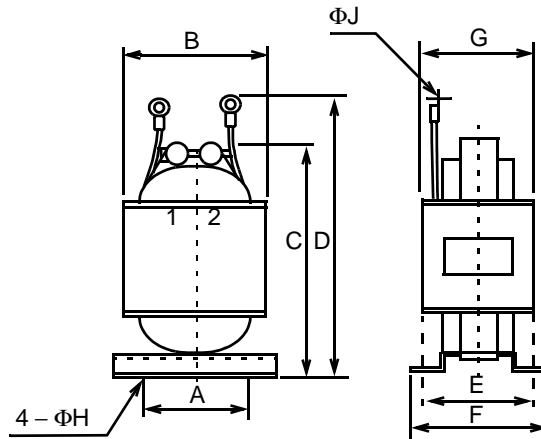

Reactor Model	Dimensions in (mm)									Approximate Mass lb (kg)
	A	B	C	D	E	F	G	ΦH	ΦJ	
X5063	1.38 (35)	2.05 (52)	3.54 (90)	4.13 (105)	1.38 (35)	1.77 (45)	1.97 (50)	0.16 (4)	0.17 (4.3)	1.323 (0.6)
X5062	1.57 (40)	2.32 (59)	3.94 (100)	4.72 (120)	1.57 (40)	1.97 (50)	2.17 (55)	0.16 (4)	0.17 (4.3)	1.984 (0.9)
X5061	1.38 (35)	2.05 (52)	3.15 (80)	3.73 (95)	1.38 (35)	1.77 (45)	1.97 (50)	0.16 (4)	0.17 (4.3)	1.102 (0.5)
X5060	1.57 (40)	2.32 (59)	4.13 (105)	4.92 (125)	1.77 (45)	2.36 (60)	2.56 (65)	0.16 (4)	0.17 (4.3)	2.21 (1.0)
X5059	1.97 (50)	2.91 (74)	4.92 (125)	5.51 (140)	1.38 (35)	1.77 (45)	2.36 (60)	0.20 (5)	0.21 (5.3)	2.43 (1.1)
X5068	1.97 (50)	2.91 (74)	4.92 (125)	6.1 (155)	2.09 (53)	2.6 (66)	2.95 (75)	0.20 (5)	0.25 (6.4)	4.19 (1.9)
X5069	1.25 (40)	2.32 (59)	4.13 (105)	4.92 (125)	1.77 (45)	2.36 (60)	2.56 (65)	0.16 (4)	0.21 (5.3)	2.205 (1.0)
X5070	1.57 (40)	2.32 (59)	3.94 (100)	4.72 (120)	1.38 (35)	1.77 (45)	1.97 (50)	0.16 (4)	0.17 (4.3)	1.764 (0.8)
X5071	1.38 (35)	2.05 (52)	3.15 (80)	3.74 (95)	1.18 (30)	1.57 (40)	1.77 (45)	0.16 (4)	0.17 (4.3)	1.102 (0.5)
X5078	1.97 (50)	2.91 (74)	4.92 (125)	6.1 (155)	2.36 (60)	2.76 (70)	3.15 (80)	0.20 (5)	0.21 (5.3)	4.41 (2.0)
X5079	1.97 (50)	2.91 (74)	4.92 (125)	5.51 (140)	1.38 (35)	1.77 (45)	2.36 (60)	0.20 (5)	0.17 (4.3)	2.65 (1.2)

Typical Internal Connection Diagrams

- 0.5kW to 1.5kW, 200V Models

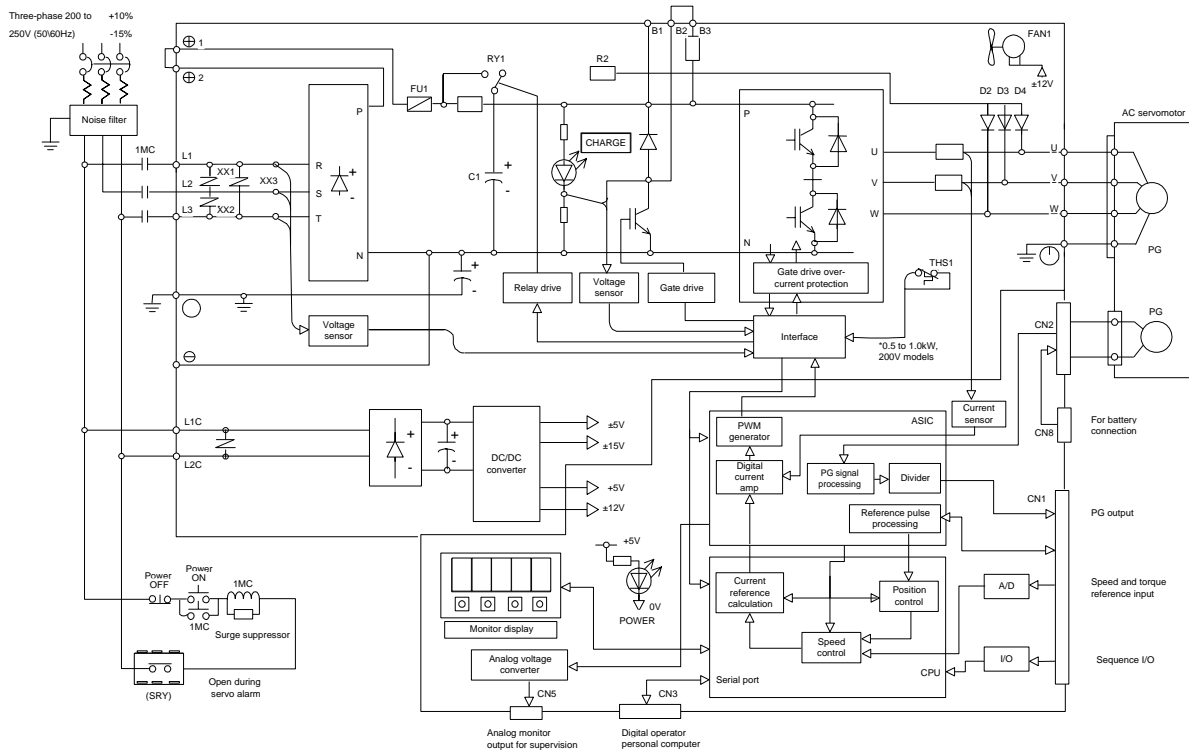

- 2.0kW to 5.0kW, 200V Models

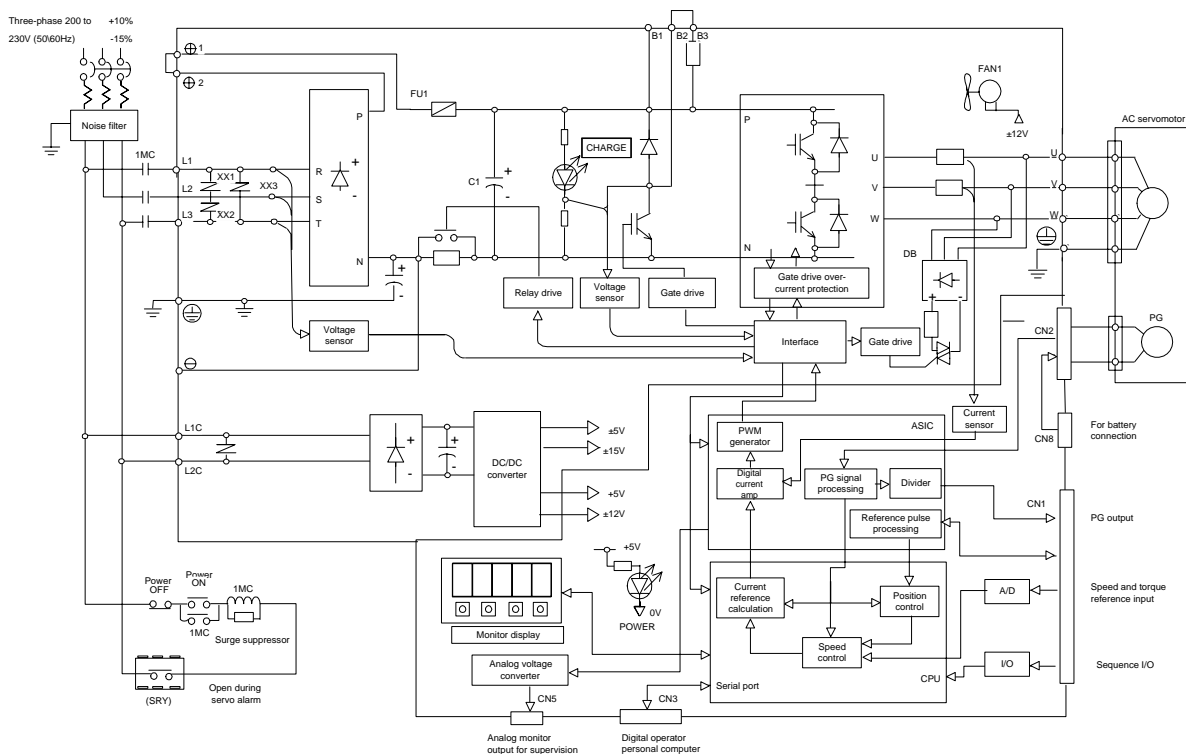

100/200V Sigma II Servo System

- 6.0kW to 7.5kW, 200V Models

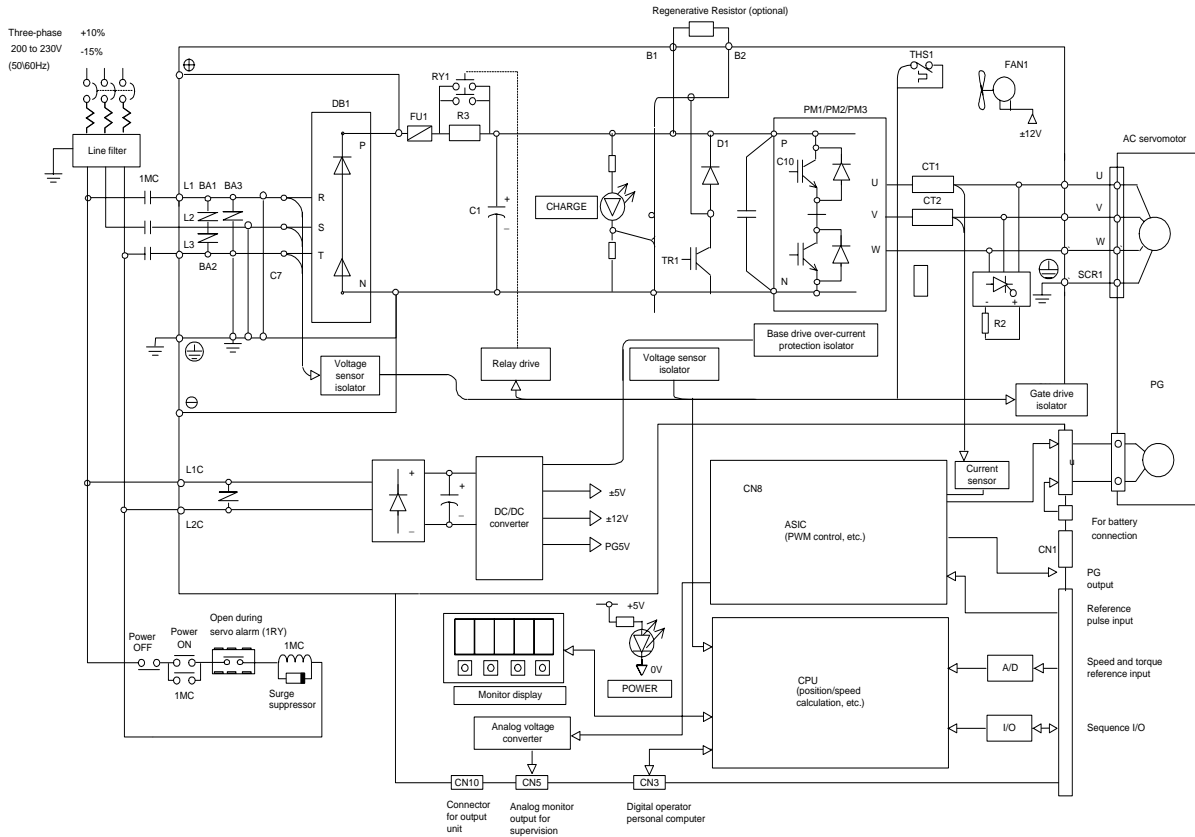

Connection Diagram, Single-phase

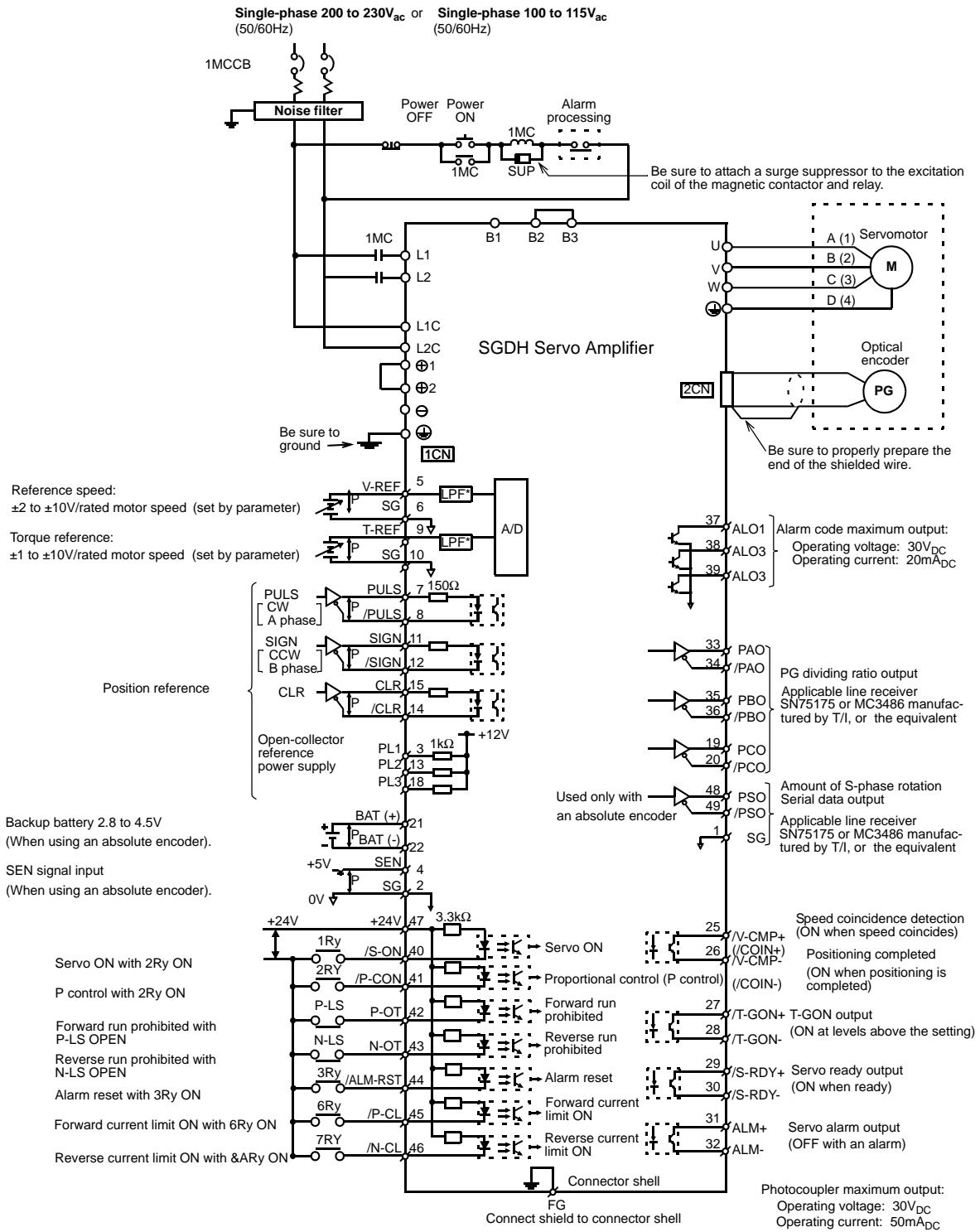

SGDH Servo Amplifiers

Connection Diagram, Three-phase

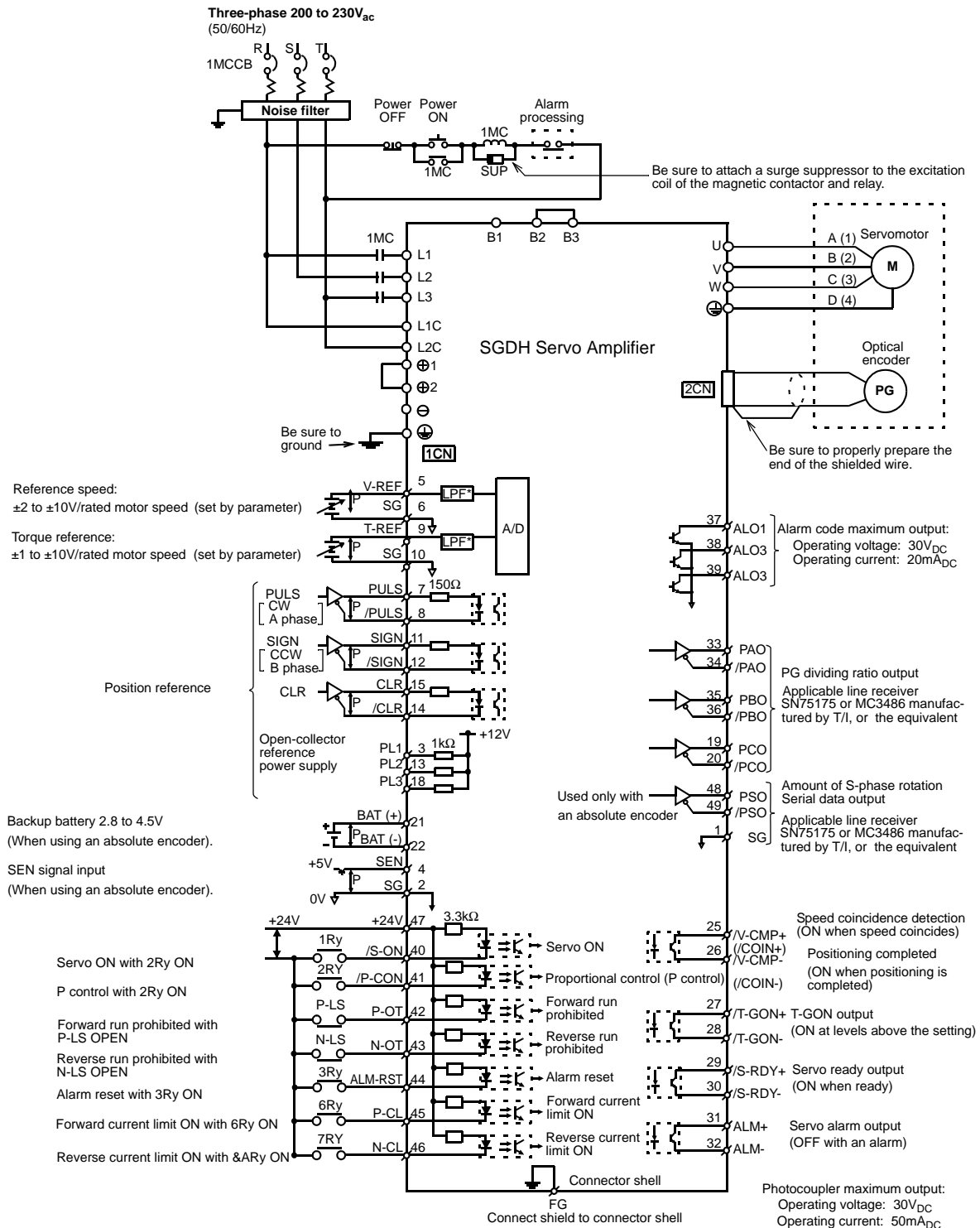

*The time constant for the primary filter is 47μs

⌋ P: Indicates twisted wire pairs.

Connector Terminal Block Converter Unit JUSP-TA50P

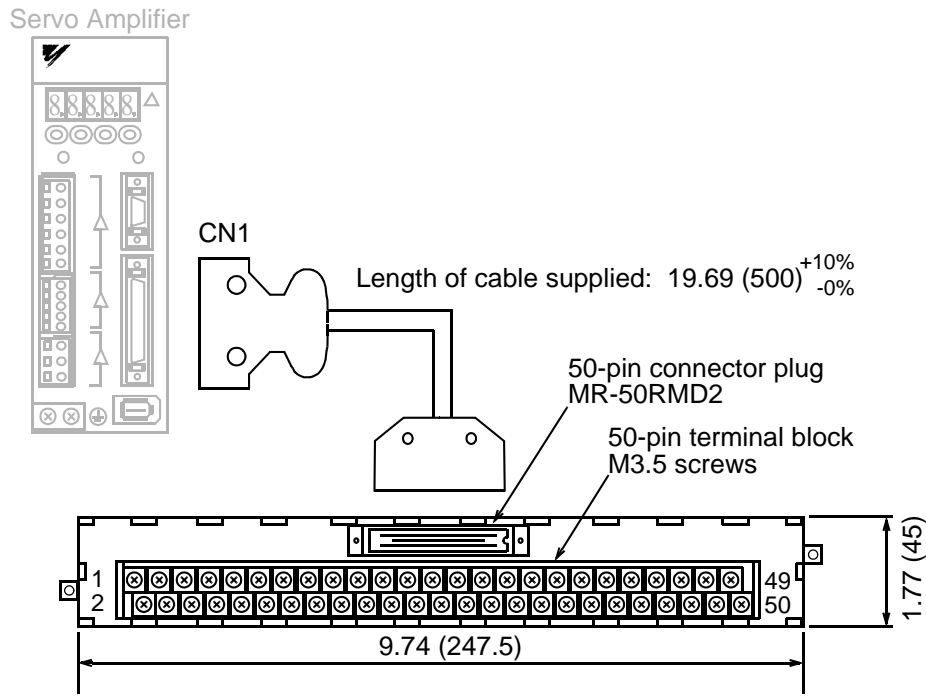

Connector Terminal Block Converter Unit
JUSP-TA50P* (cable included)

Mounting Hole Diagram

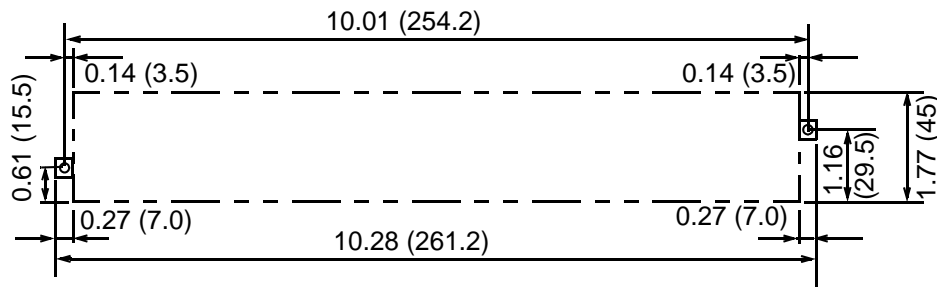

*Terminal specifications : See the following page

JUSP-TA50P Terminal Block Pin Numbers and Signal Names

SGDH Servo Amplifier			JUSP-TA50P Terminal Block Unit		
Signal Name*		CN1 Pin Number		Connector Number	Terminal Block Number
SG		1		A1	1
SG		2		B1	2
PL1		3		A2	3
SEN		4		B2	4
V-REF		5		A3	5
SG		6		B3	6
PULS		7		A4	7
/PULS		8		B4	8
T-REF		9		A5	9
SG		10		B5	10
SIGN		11		A6	11
/SIGN		12		B6	12
PL2		13		A7	13
/CLR		14		B7	14
CLR		15		A8	15
		16		B8	16
		17		A9	17
PL3		18		B9	18
PCO		19		A10	19
/PCO		20		B10	20
BAT (+)		21		A11	21
BAT (-)		22		B11	22
		23		A12	23
		24		B12	24
/V-CMP+		25		A13	25
/V-CMP-		26		B13	26
/TGON+		27		A14	27
/TGON-		28		B14	28
/S-RDY+		29		A15	29
/S-RDY-		30		B15	30
ALM+		31		A16	31
ALM-		32		B16	32
PAO		33		A17	33
/PAO		34		B17	34
BPO		35		A18	35
/PBO		36		B18	36
ALO1		37		A19	37
ALO2		38		B19	38
ALO3		39		A20	39
/S-ON		40		B20	40
/P-CON		41		A21	41
P-OT		42		B21	42
N-OT		43		A22	43
/ALM-RST		44		B22	44
/P-CL		45		A23	45
/N-CL		46		B23	46
+24V IN		47		A24	47
PSO		48		B24	48
/PSO		49		A25	49
		50		B25	50
Connector Case					

Cable: Supplied with the terminal block
 †P: Indicates twisted pair wires.

*Preconfigured amplifier inputs and outputs are listed above as they are designated when the unit is shipped from the factory. Use the connection diagrams on the previous pages for more functional details.

Amplifier to Encoder Connection Diagram

Connection Example

The following diagrams show the procedure for wiring a servo amplifier to an encoder.

Connecting an encoder (CN2) and output signals from the servo amplifier (CN1)

Incremental Encoders

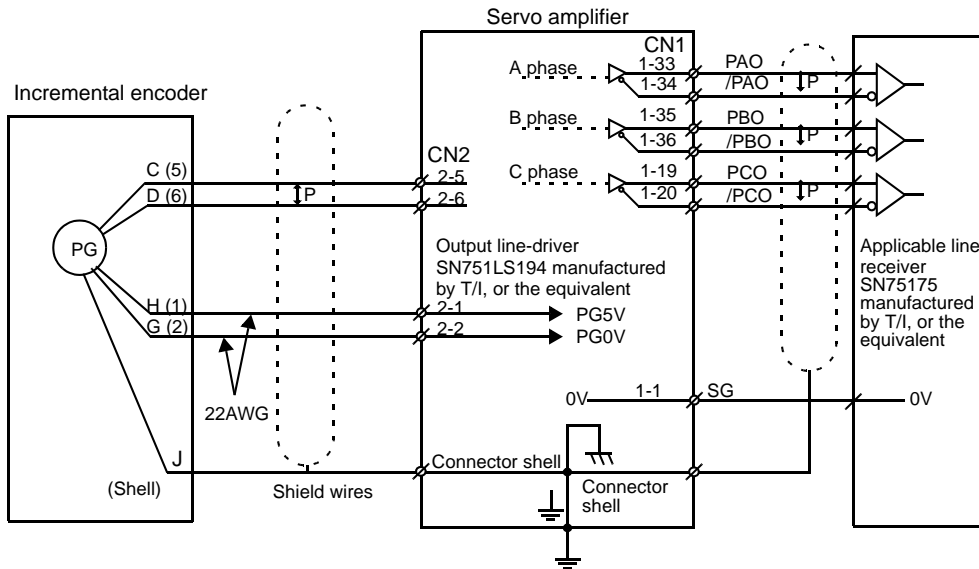

Absolute Encoders

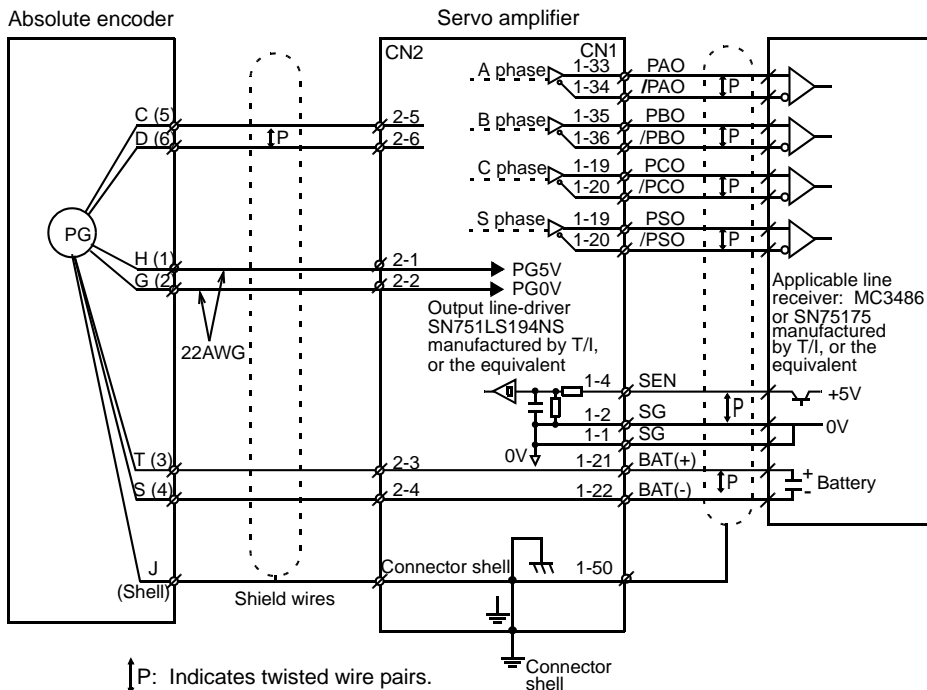

↑P: Indicates twisted wire pairs.

Overload Characteristics

Servo amplifiers have a built-in overload protection function that protects the servo amplifiers and servo motors from overload. Allowable power for the servo amplifiers is limited by the overload protective function, as shown in the figure below.

The overload detection level is set under hot start conditions at a servomotor ambient temperature of 40°C.

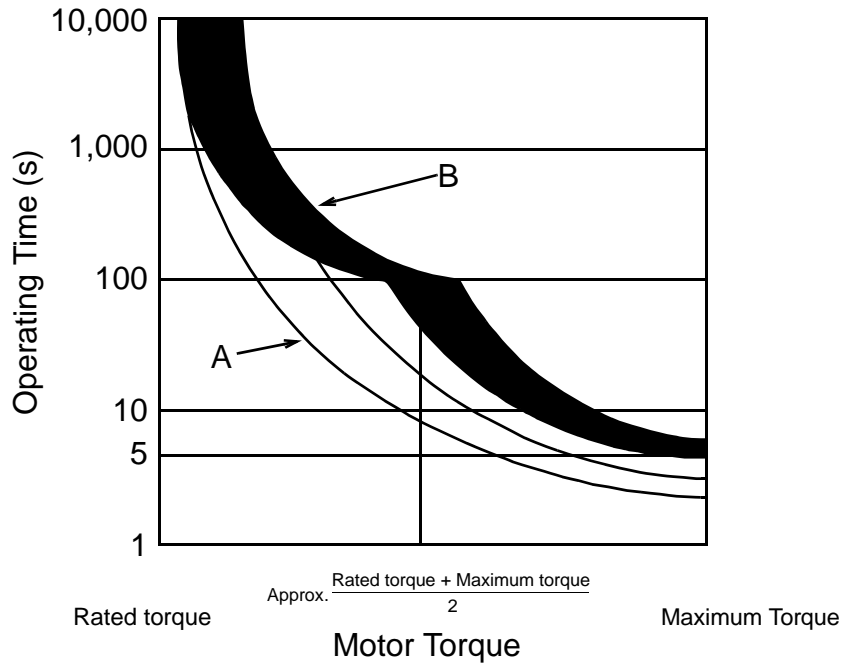

Note: The overload protection characteristics of A and B in the figure are applicable when the servo amplifier is combined with one of the following servomotors:

A: SGMAH or SGMPH servomotor with a maximum capacity of 400W.

B: Other servomotors similar to the SGMAH, SGMPH, SGMGH, and SGMSH.

Cable Specifications and Peripheral Devices

Ratings and specifications for peripheral devices, as well as cable specifications for servo amplifiers are summarized in the tables below.

 CAUTION
Wiring Precautions
<ul style="list-style-type: none"> • Do not bundle or run power and signal lines together in the same duct. Keep power and signal lines at least 11.81" (30cm) apart. • Use twisted pair or shielded multi-core twisted pair wires for signal and encoder (PG) feedback lines. • The maximum lengths for signal lines are as follows: <ul style="list-style-type: none"> • Maximum of 9.84ft (300cm) for reference input lines. • Maximum of 65.6ft (20m) for PG feedback lines. • Use a cable with 164 ft (50m) specifications for distances over 65.6ft (20m).

Cable Specifications

The following table provides wire size specifications:

External Terminal Name		SGDH Terminal Symbol	Wire Size AWG [in ² (mm ²)]				
			A3AE	A5AE	01AE	02AE	04AE
for 200V	Main circuit power input terminals	L1, L2 (Single Phase)	16 AWG [HIV 0.002 (1.25)]			14 AWG [0.003 (2.0)]	
	Servomotor connection terminals	U, V, W	16 AWG [HIV 0.002 (1.25)]				
	Control power supply terminals	L1C, L2C					
	Control I/O signal connector	CN1	Twisted pair or shielded twisted pair wires Core wire at least 28 AWG [0.0002 (0.12)], tinned, annealed copper twisted wires Finished cable dimensions: maximum Φ 0.63in (16mm) for CN1 and Φ 0.27in (6.8mm) for CN2.				
	PG signal connector	CN2					
	Ground terminal		14 AWG [HIV 0.003 (2.0)]				

External Terminal Name		SGDH Terminal Symbol	Wire Size AWG [in ² (mm ²)]	
			08AE-S	15AE-S
for 200V	Main circuit power input terminals	L1, L2 (Single Phase)	14 AWG [0.003 (2.0)]	12 AWG [0.0054 (3.5)]
	Servomotor connection terminals	U, V, W		
	Control power supply terminals	L1C, L2C	16 AWG [HIV 0.002 (1.25)]	14 AWG [0.003 (2.0)]
	Control I/O signal connector	CN1	Twisted pair or shielded twisted pair wires Core wire at least 28 AWG [0.0002 (0.12)], tinned, annealed copper twisted wires Finished cable dimensions: maximum Φ 0.63in (16mm) for CN1 and Φ 0.27in (6.8mm) for CN2.	
	PG signal connector	CN2		
	Ground terminal		14 AWG [HIV 0.003 (2.0)]	

Cable Specifications (cont'd)

External Terminal Name		SGDH Terminal Symbol	Wire Size AWG [in ² (mm ²)]				
			05AE	08AE	10AE	15AE	20AE
for 200V	Main circuit power input terminals	L1, L2, L3 (Three-phase)	14 AWG [HIV 0.003 (2.0)]				12 AWG [HIV 0.005 (3.5)]
	Servomotor connection terminals	U, V, W					
	Control power supply terminals	L1C, L2C	16 AWG [HIV 0.002 (1.25)]				
	Control I/O signal connector	CN1	Twisted pair or shielded twisted pair wires Core wire at least 28 AWG [0.0002 (0.12)], tinned, annealed copper twisted wires. See page 122 for details. Finished cable dimensions: maximum Φ 0.63in (16mm) for CN1 and Φ 0.27in (6.8mm) for CN2.				
	PG signal connector	CN2					
	Ground terminal		14 AWG [HIV 0.003 (2.0)]				

External Terminal Name		SGDH Terminal Symbol	Wire Size AWG [in ² (mm ²)]			
			30AE	50AE	60AE	75AE
for 200V	Main circuit power input terminals	L1, L2, L3 (Three-phase)	12 AWG [HIV 0.005 (3.5)]	10 AWG [HIV 0.009 (5.5)]	8 AWG [HIV 0.012 (8)]	6 AWG [HIV 0.022 (14)]
	Servomotor connection terminals	U, V, W	10 AWG [HIV 0.009 (5.5)]	8 AWG [HIV 0.012 (8)]	6 AWG [HIV 0.022 (14)]	
	Control power supply terminals	L1C, L2C	16 AWG [HIV 0.002 (1.25)]			
	Control I/O signal connector	CN1	Twisted pair or shielded twisted pair wires Core wire at least 28 AWG [0.0002 (0.12)] tinned, annealed copper twisted wires. See page 122 for details. Finished cable dimensions: maximum Φ 0.63in (16mm) for CN1 and Φ 0.27in (6.8mm) for CN2.			
	PG signal connector	CN2				
	Ground terminal		14 AWG [HIV 0.003 (2.0)]			

External Terminal Name		SGDH Terminal Symbol	Wire Size AWG [in ² (mm ²)]	
			1AAE	1EAE
for 200V	Main circuit power input terminals	L1, L2, L3 (Three-phase)	4 AWG. [HIV 0.022 (14)]	
	Servomotor connection terminals	U, V, W		
	Control power supply terminals	L1C, L2C	16 AWG [HIV 0.002 (1.25)]	
	Control I/O signal connector	CN1	Twisted pair or shielded twisted pair wires Core wire at least 28 AWG [0.0002 (0.12)], tinned, annealed copper twisted wires. See page 122 for details. Finished cable dimensions: maximum Φ 0.63in (16mm) for CN1 and Φ 0.27in (6.8mm) for CN2.	
	PG signal connector	CN2		
	Ground terminal		14 AWG [HIV 0.003 (2.0)]	

- Notes:
1. Wire sizes were selected for three cables per bundle at 40°C ambient temperature with the rated current.
 2. Use cables with a minimum withstand voltage of 600V for main circuits.
 3. If cables are bundled in PVC or metal ducts, consider the reduction ratio of the allowable current.
 4. Use heat-resistant cable under high ambient or panel temperatures where normal vinyl cable will rapidly deteriorate.

Cable Specifications (cont'd)

External Terminal Name		SGDH Terminal Symbol	Wire Size AWG [in^2 (mm^2)]			
			A3BE	A5BE	01BE	02BE
for 100V	Main circuit power input terminals	L1, L2 (Single Phase)	16 AWG [HIV 0.002 (1.25)]		14 AWG [0.003 (2.0)]	
	Servomotor connection terminals	U, V, W	16 AWG [HIV 0.002 (1.25)]			
	Control power supply terminals	L1C, L2C				
	Control I/O signal connector	CN1	Twisted pair or shielded twisted pair wires Core wire at least 28 AWG [0.0002 (0.12)], tinned, annealed copper twisted wires. See page 122 for details. Finished cable dimensions: maximum $\Phi 0.63\text{in}$ (16mm) for CN1 and $\Phi 0.27\text{in}$ (6.8mm) for CN2.			
	PG signal connector	CN2				
	Ground terminal					

The following table shows types of cables. It is used in conjunction with the preceding tables.

Cable Type		Temperature Rating of Conductor °C
Name	Composition	
PVC	Standard polyvinyl chloride cable	—
IV	600V PVC cable	60
HIV	Temperature-resistant vinyl cable	75

The following table specifies the appropriate cables for CN1 and CN2 servo amplifier connectors.

Wire sizes were selected with the expectation of three cables per bundle, at an ambient temperature of 40°C, at the rated current level.

Connector Name	Signal	Description	Specification
Control I/O Signal Connector	CN1	Cable	Use twisted pair or shielded twisted pair wire.
		Applicable wire	(AWG): 24, 26, 28
		Finished cable Dimension	$\Phi 0.63$ ($\Phi 16.0$) maximum
PG Signal Connector	CN2	Cable	Use Yaskawa cable, or shielded twisted pair wire.
		Applicable wire	(AWG): 22, 24, 26 Use 22 AWG [0.0005 in^2 (0.34 mm^2)] for the encoder power supply and 26 AWG [0.0002 in^2 (0.14 mm^2)] for other signals. These conditions permit wiring distances up to 65.6ft (20m).
		Finished cable Dimension	$\Phi 0.27$ ($\Phi 6.8$) maximum

Peripheral Device Types and Capacities

Main Circuit Power Supply	Amplifier Model		Control Power Required (W)	Applicable Servomotor	Power Supply				Recommended Noise Filter**		Motor Magnetic Contactor
	Capacity (kW)	SGDH-			Capacity per Servo Amplifier (kVA)	Rated Main Power (A _{rms})	Maximum Inrush Current (A _{rms})	MCCB or Fuse Capacity* (A _{rms})	Model	Specifications	
Single-phase 100V	0.03	A3BE	13	SGMAH-A3B	0.15	1.1	28	4	Fn2070-6/07 (or FS5827-4-07)	Single-phase 250V _{ac} 6A (4A)	(10A) or equivalent
	0.05	A5BE		SGMAH-A5B	0.25	1.8					
	0.10	01BE		SGMAH-01B	0.40	2.0					
				SGMPH-01B							
	0.20	02BE		SGMAH-02B	0.60	5.2					
				SGMPH-02B							
Single-phase 200V	0.03	A3AE	13	SGMAH-A3A	0.20	0.82	28	4	Fn2070-6/07 (or FS5827-4-07)	Single-phase 250V _{ac} 6A (4A)	(20A) or equivalent
	0.05	A5AE		SGMAH-A5A	0.25	1.1					
	0.10	01AE		SGMAH-01A	0.40	2.0					
				SGMPH-01A							
	0.20	02AE		SGMAH-02A	0.75	3.4					
				SGMPH-02A							
	0.40	04AE		SGMAH-04A	1.2	5.5					
				SGMPH-04A							
0.75	08AE-S	SGMAH-08 SGMPH-08	2.1	11.0	11	Fn2070-16/07 (or FS5827-15-07)	Single-phase 250V _{ac} 16A (15A)	(20A) or equivalent			
1.5	15AE-S	SGMPH-15	4.0	19.0	19	Fn350-30/33 (or FS5827-25-07)	Single-phase 250V _{ac} 30A (25A)	35A or equivalent			
Three-phase 200V	0.50	05AE	15	SGMGH-05AOA	1.4	4.0	56	4	Fn258L-16/07	Three-phase 480V _{ac} 16A	(20A) or equivalent
	0.75	08AE		SGMAH-08A	1.9	5.4					
				SGMPH-08A							
	1.0	10AE		SGMGH-09AOA	2.3	7.0					
				SGMSH-10A							
	1.5	15AE		SGMPH-15A	3.2	9.5					
				SGMGH-13AOA							
	2.0	20AE		SGMSH-15A	4.3	12.0					
				SGMGH-20AOA							
	3.0	30AE		SGMSH-20A	5.9	17.0					
				SGMGH-30AOA							
	5.0	50AE		SGMSH-30A	7.5	24					
SGMGH-44 SGMSH-50											
6.0	60AE	SGMGH-55	12.5	32	32	Fn258L-42/07	Three-phase 480V _{ac} 42A	(35A) or equivalent			
7.5	75AE	SGMGH-75	15.5	41	41	Fn258L-55/07	Three-phase 480V _{ac} 55A	50A or equivalent			
11.0	1AAE	SGMGH-1A	19.0	60	116	60	FS5559-150-35	Three-phase 250V _{ac} 150A	65A or equivalent		
15.0	1EAE	SGMGH-1E	30.0	80						80	

* Size per local code requirements . Typical fuse interrupting characteristics at 25°C: 200% for 2s minimum; 700% for 0.01s minimum.

** The Fn□□□□ noise filter is manufactured by Schaffner Corporation. Specifications are available at: www.schaffner.com .

Peripheral Device Manufacturers

J.S.T. Corporation

1957 South Lakeside Drive
Waukegan, Illinois 60085

Phone: (847) 473-1957
<http://www.jst.com>

Molex (Headquarters)

*(Note: not selling 2CN serial
encoder connector in the US)*
2222 Wellington Court
Lisle, Illinois 60532

Phone: (630) 527-4474
Fax: (630) 548-2897

(Connector information is not
available from Molex or Yaskawa)

For literature requests or Molex
support for the 2CN connector,
the Chicago area distributor isTTI.
Ask for the Yaskawa inside sales
representative.
1-800-CALLTTI
(1-800-225-5884)

Schaffner EMC Inc.

52 Mayfield Ave.
Edison, New Jersey 08837

Phone: 1-800 367-5566
(732) 225-9533
Fax: (732) 225-4789
<http://www.shaffner.com>

TDK Corporation of America

1600 Feehanville Dr.
Mount Prospect, Illinois 60056

Phone: (847) 803-6100
Fax: (847) 803-6296

Tokin America

32950 Alvarado-Niles Rd.
Suite 500
Union City, California 94507

Phone: (510) 324-4110
Fax: (510) 324-1762
<http://www.tokin.com>

NOTES:

General Purpose SGMGH Servomotors - With Incremental / Absolute Encoder

Rated Output: 0.45kW, 0.85kW,
1.3kW, 1.8kW, 2.9kW,
4.4kW, 5.5kW, 7.5kW,
11kW, 15kW.



For Additional Information	Page(s)
SGMGH Ratings & Specifications	128
SGMGH Speed/Torque Curves	129
SGMGH Dimensions	130 - 132
SGMGH Selection/Ordering Information	133 - 138
SGDH (400V) Ratings & Specifications	167 - 168
SGDH Dimensions	169 - 188

Design Features

1. Compact

- Small sized motor
 - Compatible with previous generation G series motors
 - Ten types of rated outputs ranging from 0.79 to 1988in •lb of peak torque
 - Optional built-in holding brake available

2. Higher Speed and acceleration

- Up to 3000rpm maximum
- High torque to inertia ratio

3. Encoders

- 17-bit (32,768 ppr x 4) incremental encoder (standard)
- 17-bit absolute encoder (optional)

4. Enhanced Environmental Resistance

- Totally enclosed, self-cooled IP67 (excluding shaft)
- Shaft seal (optional)

5. Application Emphasis

- Machine tools and woodworking machines
- Packaging machines
- Gantry robots
- Press automation
- Thermoforming

6. Certified International Standards

- UL, cUL recognized (File #: E165827) CE compliance

Servomotor Ratings and Specifications

Time Rating:	Continuous	Enclosure:	Totally-enclosed, self-cooled	Maximum Rotational Speed*:	
Insulation:	Class F		IP67 (except for shaft opening)	0.45 to 7.5kW: 3000rpm	
Vibration:	15µm or less	Ambient Temperature:	0 to 40°C	11 and 15kW: 2000rpm	
Withstand Voltage:	1500V _{ac}	Ambient Humidity:	20 to 80%	Excitation:	Permanent magnet
Insulation Resistance:	10MΩ minimum at 500V _{DC}	Rated Speed*:	1500rpm	Drive Method:	Direct drive
				Mounting:	Flange-mounted

* Values when the servomotor is combined with an SGDH servo amplifier.

Amplifier System Voltage	MOTORS: SGMGH-	Rated Output*	Rated Torque*		Instantaneous Peak Torque*		Rated Current*	Instantaneous Maximum Current*
		kW (hp)	N • m	lb _f • in (KG • cm)	N • m	lb _f • in (KG • cm)	A _{rms}	A _{rms}
400V _{ac}	05D□A	0.45 (0.6)	2.84	25 (29)	8.92	79 (91)	1.9	5.5
	09D□A	0.85 (1.1)	5.39	48 (55)	13.8	122 (141)	3.5	8.5
	13D□A	1.3 (1.7)	8.34	74 (85)	23.3	207 (238)	5.4	14.0
	20D□A	1.8 (2.4)	11.5	102 (117)	28.7	254 (293)	8.4	20.0
	30D□A	2.9 (3.9)	18.6	165 (190)	45.1	400 (460)	11.9	28.0
	44D□A	4.4 (5.9)	28.4	252 (290)	71.1	629 (725)	16.4	42.0
	55D□A	5.5 (7.4)	35.0	310 (357)	87.6	775 (894)	21.0	55.0
	75D□A	7.5 (10)	48.0	425 (490)	119	1053 (1210)	27.3	65.0
	1AD□A	11 (15)	70.0	620 (714)	175	1550(1790)	29.3	70.0
1ED□A	15 (20)	95.4	845 (974)	224	1988(2290)	39.0	85.0	

* Values when the servomotor is combined with an SGDH servo amplifier.

MOTORS SGMGH-	Torque Constant	Moment of Inertia		Holding Brake (at 20°C)					Allowable Load Inertia	Rated Power Rate*	Rated Angular Acceleration*	Inertia Time Constant	Inductive Time Constant
				Capacity	Torque	Coil. Resistance	Rated Current	Additional Inertia					
				W	N • m	W	A	lb • in • s ² × 10 ⁻³					
	$\frac{lb_f \cdot in}{A_{rms}} \left(\frac{N \cdot m}{A_{rms}} \right)$	$lb \cdot in \cdot s^2 \times 10^{-3}$	$KG \cdot m^2 \times 10^{-4}$					$KG \cdot m^2 \times 10^{-4}$	kW/s	rad/s ²	ms	ms	
05D□A	14.5 (1.64)	6.41	7.24	9.85	4.41	58.5	0.41	1.85	36.2	11.2	3930	5.6	4.5
09D□A	14.6 (1.65)	12.3	13.9		12.7				69.5	20.9	3880	3.1	5.3
13D□A	14.9 (1.68)	18.2	20.5		103				33.8	4060	2.9	6.1	
20D□A	12.9 (1.46)	28.1	31.7	18.5	43.1	31.1	0.77	7.75	159	41.5	3620	2.4	11.1
30D□A	14.7 (1.66)	40.7	46.0						230	75.3	4050	2.0	12.3
44D□A	16.0 (1.82)	59.8	67.5						338	120	4210	1.4	15.2
55D□A	15.6 (1.76)	78.8	89.0	23.5	72.6	24.5	0.98	7.75	445	137	3930	1.4	14.4
75D□A	16.4 (1.86)	111	125						625	184	3850	1.1	17.6
1AD□A	22.0 (2.5)	249	281						32.0	84.3	18.0	1.33	16.7
1ED□A	23.4 (2.64)	279	315	35.0	115	16.4	1.46	33.2	1575	289	3030	1.0	26.2

* Values when the servomotor is combined with an SGDH servo amplifier at an armature winding temperature of 20°C.

** These characteristics can be obtained when the following heat sinks (steel plates) are used for cooling purposes:

Type 05D□A to 13D□A:	15.75 × 15.75 × 0.79 (in)	(400 × 400 × 20 (mm))
Type 20D□A to 75D□A:	21.65 × 21.65 × 1.18 (in)	(550 × 550 × 30 (mm))
Type 1AD□A to 1ED□A:	25.59 × 25.59 × 1.38 (in)	(650 × 650 × 35 (mm))

Speed / Torque Curves

400V

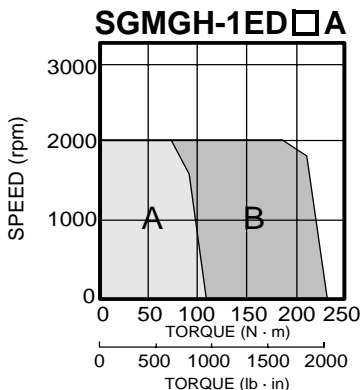
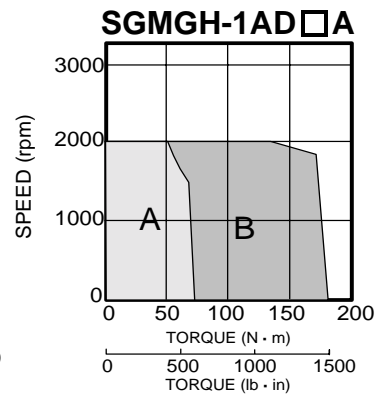
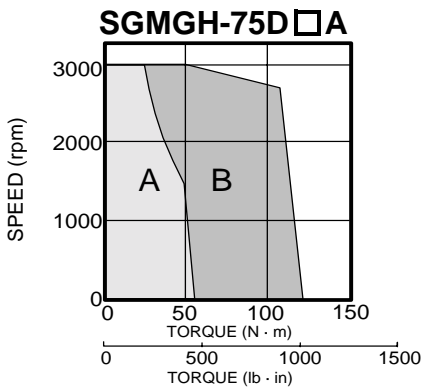
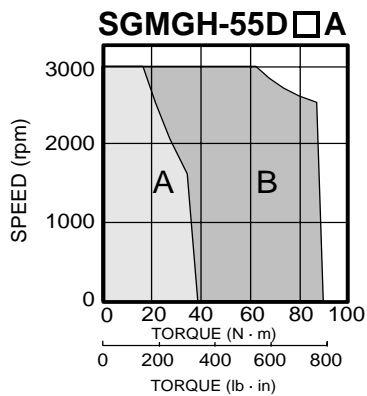
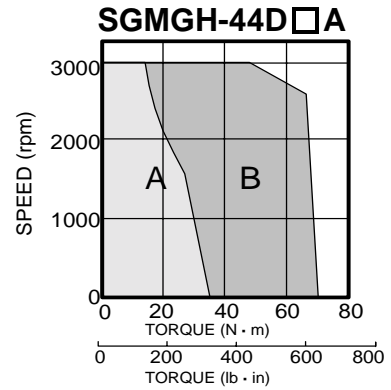
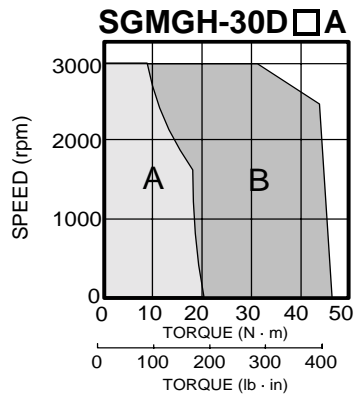
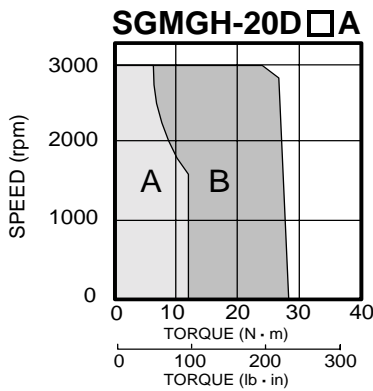
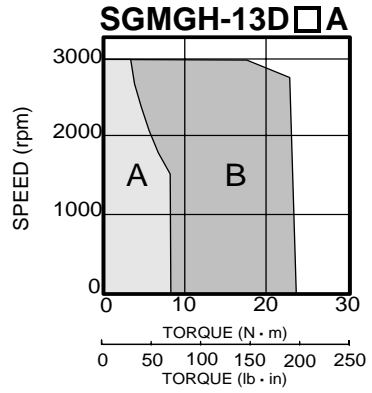
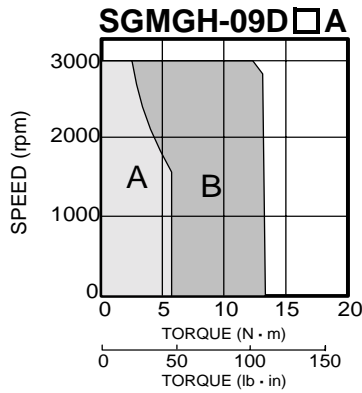
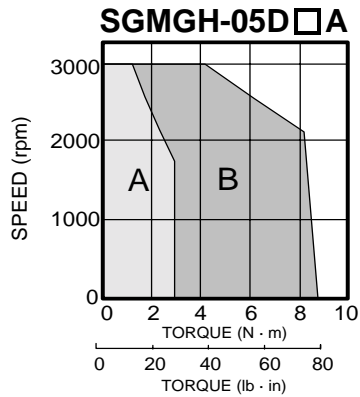

A : CONTINUOUS DUTY ZONE
B : INTERMITTENT DUTY ZONE

(2) 17-Bit Incremental/Absolute Encoder, With Brake

- 0.5 to 4.4kW (0.7 to 5.9hp)

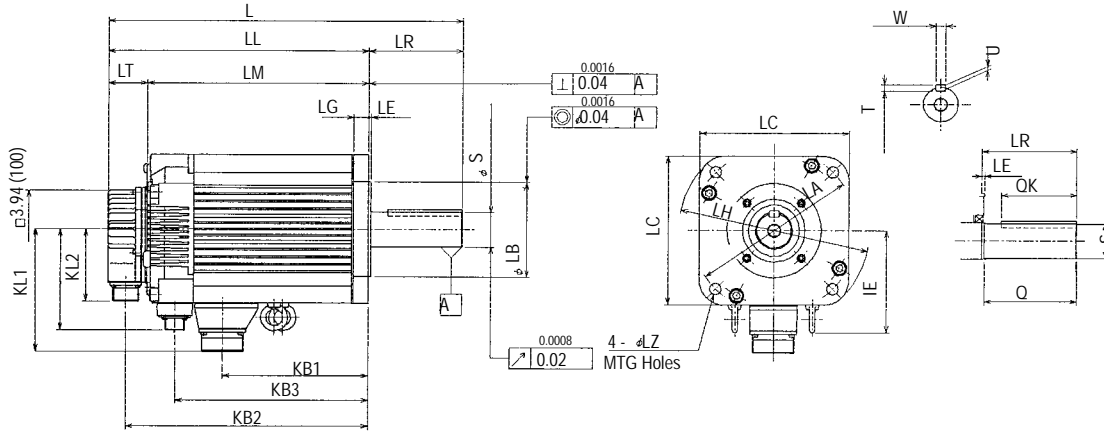

Type SGMGH-	L	LL	LM	LR	LT	KB1	KB2	KB3	KL1	KL2	Flange Dimensions						Shaft End Dimension					Approximate Mass lb _f (kg)	Allowable Radial Load lb _f (N)	Allowable Thrust Load lb _f (N)		
											phiLA	phiLB**	LC	LE	LG	LH	phiZ	phiS*	Q	OK	W				T	U
05D□A6C	9.21 (234)	6.93 (176)	5.08 (129)			2.56 (65)	6.1 (155)	4.29 (109)			5.71 (145)	4.33 (110)	5.12 (130)	0.24 (6)	0.47 (12)	6.5 (165)	0.35 (9)	0.75 (19)	1.57 (40)	0.98 (25)	0.20 (5)	0.20 (5)	0.12 (3)	16.5 (7.5)	110 (490)	22 (98)
09D□A6C	10.12 (257)	7.83 (199)	5.98 (152)	2.28 (58)		3.46 (88)	7.01 (178)	5.20 (132)	4.29 (109)		5.71 (145)	4.33 (110)	5.12 (130)	0.24 (6)	0.47 (12)	6.5 (165)	0.35 (9)	0.87 (22)	1.57 (40)	0.98 (25)	0.24 (6)	0.24 (6)	0.14 (3.5)	21.2 (9.6)	154 (686)	77 (343)
13D□A6C	11.06 (281)	8.78 (223)	6.93 (176)		1.85 (47)	4.41 (112)	7.95 (202)	6.14 (156)		3.46 (88)	7.87 (200)	4.5 (114.3)	7.09 (180)	0.13 (3.2)	0.71 (18)	9.06 (230)	0.53 (13.5)	1.38 (35)	2.99 (76)	2.36 (60)	0.39 (10)	0.31 (8)	0.20 (5)	26.5 (12)	154 (686)	77 (343)
20D□A6C	11.65 (296)	8.54 (217)	6.69 (170)			3.50 (89)	7.72 (196)	5.39 (137)			7.87 (200)	4.5 (114.3)	7.09 (180)	0.13 (3.2)	0.71 (18)	9.06 (230)	0.53 (13.5)	1.38 (35)	2.99 (76)	2.36 (60)	0.39 (10)	0.31 (8)	0.20 (5)	41.9 (19)	265 (1176)	
30D□A6C	12.68 (322)	9.57 (243)	7.72 (196)	3.11 (79)		4.53 (115)	8.74 (222)	6.42 (163)	5.51 (140)		7.87 (200)	4.5 (114.3)	7.09 (180)	0.13 (3.2)	0.71 (18)	9.06 (230)	0.53 (13.5)	1.38 (35)	2.99 (76)	2.36 (60)	0.39 (10)	0.31 (8)	0.20 (5)	51.8 (23.5)	331 (1470)	110 (490)
44D□A6C	14.02 (356)	10.91 (277)	9.06 (230)			5.87 (149)	10.08 (256)	7.72 (196)			7.87 (200)	4.5 (114.3)	7.09 (180)	0.13 (3.2)	0.71 (18)	9.06 (230)	0.53 (13.5)	1.38 (35)	2.99 (76)	2.36 (60)	0.39 (10)	0.31 (8)	0.20 (5)	62.8 (28.5)	331 (1470)	110 (490)

Note: 1. Dimensions are the same when using other incremental encoders (with or without optional shaft seal).
 2. Tolerances on the dimensions LB of flange type and S of shaft extensions are based on JIS (Japanese Industrial Standard) B0401 "Limits and Fits for Engineering."

Specified Tolerances					
Dimension	*phiS		**phiLB		
	Unit	Diameter	Tolerance	Diameter	Tolerance
in		0.7480, 0.8661	+0.0000-0.0005	4.3307	+0.0000 -0.0014
		1.3780	+0.0004-0.0000	4.5000	+0.0000 -0.0010
mm		19.000, 22.000	+0.000 -0.013	110.000	+0.000 -0.035
		35.000	+0.010 -0.000	114.300	+0.000 -0.025

Plug for Holding Brake

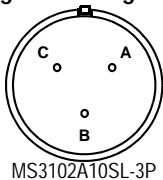

MS3102A10SL-3P

Connector Wiring on the Brake, Motor Side	
A	Brake Terminal
B	Brake Terminal
C	—

Non-Environmental Mating Connector:
 MS3108A10SL-3S (L Type)
 Cable Clamp: MS3057-4A

Plug for Motor

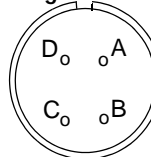

Connector Wiring on the Motor Side	
A	U Phase
B	V Phase
C	W Phase
D	FG (Frame Ground)

400V Three-phase Sigma II Servo Systems

- 5.5 to 15kW (7.4 to 20hp)

SGMGH Servomotors

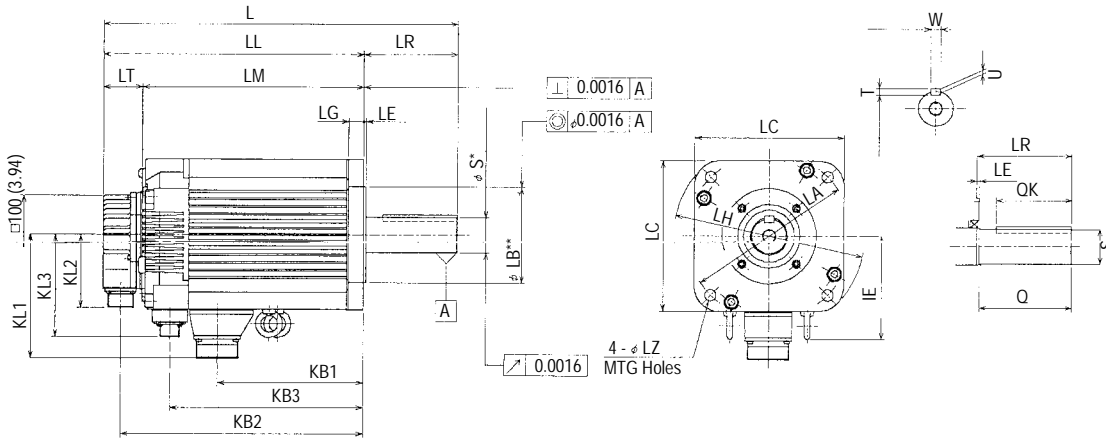

Type SGMGH-	L	LL	LM	LR	LT	KB1	KB2	KB3	IE	KL1	KL2	KL3	Flange Dimensions						Shaft End Dimension					Approximate Mass lb _f (kg)	Allowable Radial Load lb _f (N)	Allowable Thrust Load lb _f (N)			
													ΦLA	ΦLB**	LC	LE	LG	LH	ΦLZ	ΦS*	Q	OK	W				T	U	
55D□A6C	16.69 (424)	12.24 (311)	10.39 264	4.45	1.85 (47)	6.85 (174)	11.42 (290)	9.09 (231)	4.92 (125)	5.91 (150)			4.84 (123)	7.87 (200)	4.5 (114.3)	7.09 (180)	0.13 (3.2)	0.71 (18)	9.06 ((230))	0.53 (13.5)	1.65 (42)	4.33 (110)	3.54 (90)	0.47 (12)	0.31 (8)	0.20 (5)	77.2 (35)		
75D□A6C	19.61 (498)	15.16 (385)	13.31 (338)	(113)	(47)	9.76 (248)	14.33 (364)	12.01 (305)	(125)	(150)			5.91 (150)	7.87 (200)	4.5 (114.3)	7.09 (180)	0.13 (3.2)	0.71 (18)	9.06 ((230))	0.53 (13.5)	1.65 (42)	4.33 (110)	3.54 (90)	0.47 (12)	0.31 (8)	0.20 (5)	100.3 (45.5)	397 (1764)	132 (588)
1AD□A6C	19.65 (499)	15.08 (383)	13.39 (340)	(116)	(43)	10.16 (258)	14.25 (362)	12.40 (315)	(125)	(150)	3.46 (88)		5.91 (150)	7.87 (200)	4.5 (114.3)	7.09 (180)	0.16 (4)	0.79 (20)	10.63 (270)	0.53 (13.5)	1.65 (42)	4.33 (110)	3.54 (90)	0.47 (12)	0.31 (8)	0.20 (5)	145 (65.5)		
1ED□A6C	25.00 (635)	20.43 (519)	18.62 (473)	(116)	(46)	13.50 (343)	19.57 (497)	16.34 (415)	(142)	(168)			5.91 (150)	7.87 (200)	4.5 (114.3)	7.09 (180)	0.16 (4)	0.79 (20)	10.63 (270)	0.53 (13.5)	2.17 (55)	4.33 (110)	3.54 (90)	0.63 (16)	0.39 (10)	0.24 (6)	189.6 (86)	1125 (4998)	485 (2156)

Note: 1. Dimensions are the same when using either incremental or absolute encoders (with or without optional shaft seal).
 2. Tolerances on the dimensions of flange type LB and of shaft extensions S are based on JIS (Japanese Industrial Standard) B0401 "Limits and Fits for Engineering."

Specified Tolerances					
Dimension	*ΦS		**ΦLB		
	Unit	Diameter	Tolerance	Diameter	Tolerance
in		1.6535	+0.0000-0.0006	4.5000	+0.0000 -0.0010
		2.1700	+0.0012+0.0004	7.8700	+0.0000 -0.0018
mm		42.000	+0.000 -0.016	114.300	+0.000 -0.025
		55.000	+0.030 +0.011	200.000	+0.0000 -0.046

Plug for Holding Brake

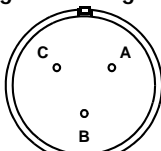

MS3102A10SL-3P

Connector Wiring on the Brake, Motor Side	
A	Brake Terminal
B	Brake Terminal
C	—

Non-Environmental Mating Connector:
 MS3108A10SL-3S (L Type)
 MS3106A10SL-3S (Straight Type)
 Cable Clamp: MS3057-4A

Motor Plug

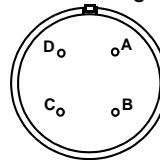

Connector Wiring on the Power, Motor Side	
A	U Phase
B	V Phase
C	W Phase
D	Ground Terminal

Selecting Your SGMGH Sigma II Servo System

First, select the Sigma II servomotor suited for your application using SigmaSize: the Yaskawa servomotor sizing software, available at no charge. (Request SigmaSize software via e-mail, at: literature@yaskawa.com).

Use the diagram below to locate and identify the components of your system. Each item is letter-coded and cross-referenced in the option tables on the following pages.

System Configuration

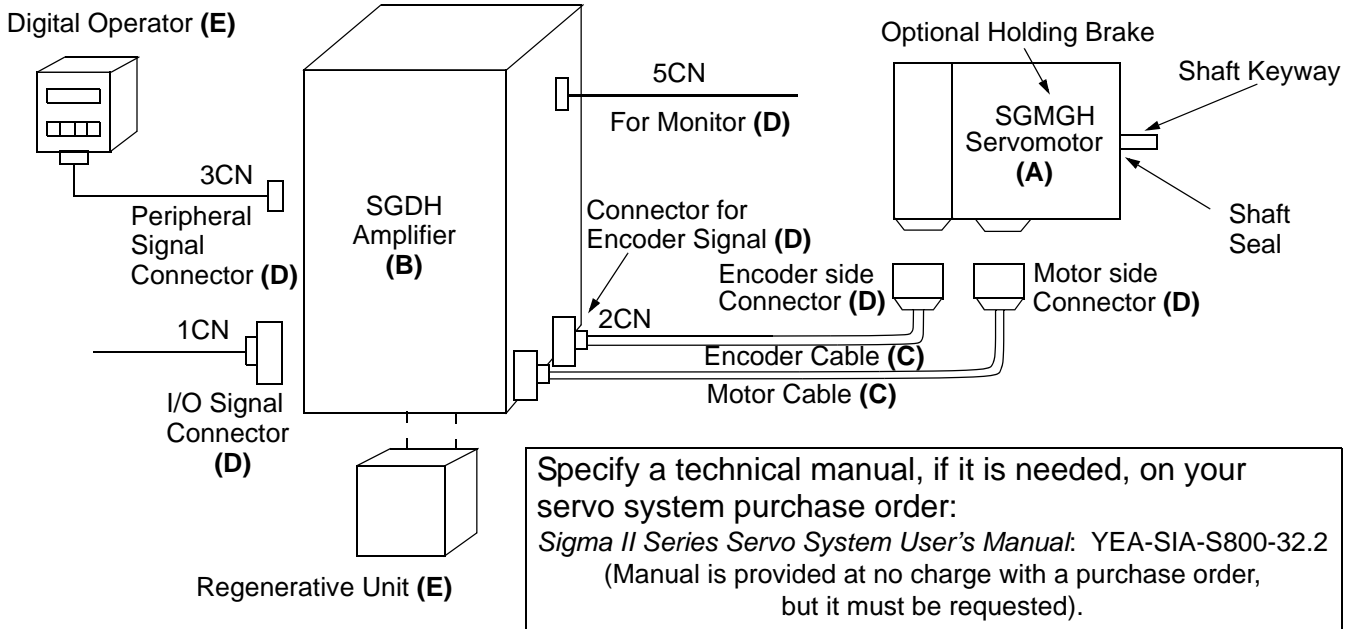

Model Number Designation

SGMGH - 09 D C A 6 [C]

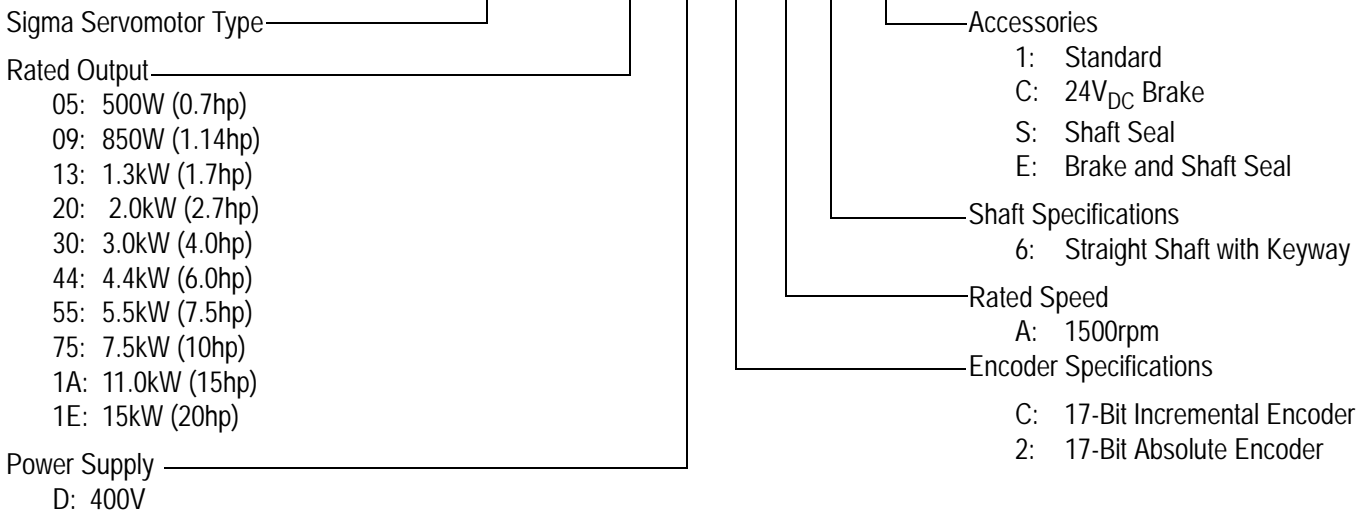

400V Three-phase Sigma II Servo Systems

Servomotor & Amplifier Selection

Use the table below to select the appropriate SGMGH Sigma II servomotor and amplifier.

(Refer to the motor model # designation on the previous page specifying the available modification to motor construction/features.)

Description	Peak Torque (in • lb)	Rated Torque (in • lb)	Motor Inertia (in • lb • s ² x 10 ⁻³)	Motor MODEL Number (A)	Amplifier MODEL # (B)* Analog/Digital Input SGDH-	Motor and Amplifier Item Class	
400V Three-Phase 17-bit Incremental Encoder Straight Shaft with Keyway 3000rpm maximum** MS Connectors	79	25	6.41	SGMGH-05DCA61	05DE	Stock	
			8.26	SGMGH-05DCA6C			
	122	48	12.30	SGMGH-09DCA61	10DE		
			14.15	SGMGH-09DCA6C			
	207	74	18.2	SGMGH-13DCA61	15DE		
			20.1	SGMGH-13DCA6C			
	254	102	28.1	SGMGH-20DCA61	20DE		
			35.9	SGMGH-20DCA6C			
	404	165	40.7	SGMGH-30DCA61	30DE		
			48.5	SGMGH-30DCA6C			
	630	252	59.8	SGMGH-44DCA61	50DE		
			67.6	SGMGH-44DCA6C			
	776	310	78.8	SGMGH-55DCA61	60DE Requires Regenerative Unit (E)		
			86.6	SGMGH-55DCA6C			
	1050	425	111	SGMGH-75DCA61	75DE Requires Regenerative Unit (E)		
			119	SGMGH-75DCA6C			
	1550	620	249	SGMGH-1ADCA61	1ADE Requires Regenerative Unit (E)		Limited Stock
			267	SGMGH-1ADCA6C			
1988	845	279	SGMGH-1EDCA61	1EDE Requires Regenerative Unit (E)	Stock		
		309	SGMGH-1EDCA6C			Limited Stock	

Note: 24V_{DC} brakes for SGMGH Sigma II servomotors are standard. Contact a local source for 24V_{DC} power supplies. For technical information, request Yaskawa manual number YEA-SIA-S800-32.2.

* For more detailed SGDH amplifier specifications and dimensions, refer to pages 167 - 188.

**2000rpm maximum for 11 and 15kW systems only.

Pre-wired Cable Selection

Use the table below to select pre-wired cables for your SGMGH Sigma II servomotor.

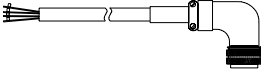
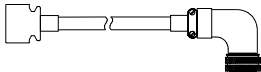
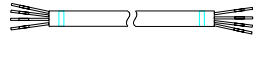
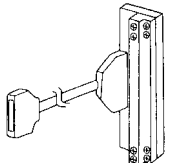
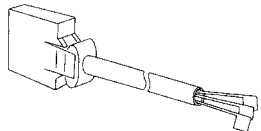
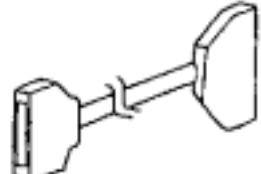
Cable Description (C)		Motor Size (kW)	Part Number*	Comments	Item Class
Power Cable with Connectors (IP67)		0.5, 0.9, 1.3	BAE-□□(A)	Use the following key to specify needed cable length (last two digits of the part number): 03: 3m 05: 5m 10: 10m (standard) 15: 15m 20: 20m	
		2.0, 3.0, 4.4	BBE-□□(A)		
		5.5, 7.5, 11	BDE-□□(A)		
		15	B5E-□□(A)		
Power Cable for Holding Brake (IP67)			B7BCE-□□(A)		
Encoder Cable (incremental or absolute) (IP67)			JZSP-CMP02-□□(B)	These cables are available in five lengths. Use two digits in the part number's last place: 03: 3m 05: 5m 10: 10m (standard) 15: 15m 20: 20m	Stock**
Encoder Cable (for applications up to 20m) Only for Solder Connections			FR-RMCT-SB	These cables are available in any length. For example, to order one FR-RMCT-SB cable, 16m long, specify: quantity: 16 part no.: FR-RMCT-SB	
Encoder Cable (for applications from >20 to <50m) Only for Solder Connections			UL20276-SB		
Input/Output 1CN Cable & Transition Terminal lock		All	JUSP-TA50P	35 mm DIN rail mountable; the cable length is 0.5m.	
Input/Output 1CN Cable with Pigtail Leads			JZSP-CKI01-□(A)	Use the following key to specify needed cable length (last digit of part number): 1: 1m (standard) 2: 2m 3: 3m	
Input/Output 1CN Cable Cable with Female D-Sub output Connector***			JZSP-CKI0D-□□	Use the following key to specify required cable length (last two digits of the part number): D50: 0.5m 01: 1m (standard) 02: 2m 03: 3m	



* (A)" at the end of the cable number is the revision level. The revision level may be changed prior to this catalog's reprinting.

** Standard cable lengths are Stock items; non-standard cable lengths are Limited Stock items.

*** 50 Pin Female D-Sub output connector mates to customer supplied third party terminal block. (e.g., Wago #289-449, Weidmuller #919658, Phoenix #2283647, Amphenol/Sine #20-51039, and many others).

Connector Selection

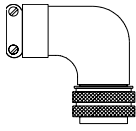
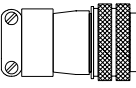
Use the table below to select mating connectors for each SGMGH Sigma II servomotor.

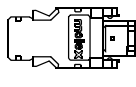
Connector Description (D)		Motor Size (kW)	Part Number	Comments	Item Class
MS Connector for Motor Power Cable*		0.5, 0.9, 1.3	MS3106B18-10S	Straight-type connector	Stock
			MS3108B18-10S	L-type connector	
			MS3057-10A	Cable clamp	
		2.0, 3.0, 4.4	MS3106B22-22S	Straight-type connector	
			MS3108B22-22S	L-type connector	
			MS3057-12A	Cable clamp	
		5.5, 7.5, 11, 15	MS3106B32-17S	Straight-type connector	
			MS3108B32-17S	L-type connector	
			MS3057-20A	Cable clamp	
MS Connector for Brake Power Cable		All	MS3108A10SL-3S MS3057-4A	L-type connector Cable clamp	
MS Connector for Encoder Cable (incremental or absolute encoder)			MS3106B20-29S	Straight-type connector	
			MS3108B20-29S	L-type connector	
			MS3057-12A	Cable clamp	
1CN Mating Connector			JZSP-CKI9	—	
2CN Encoder Mating Connector			JZSP-CMP9-1	—	
3CN Peripheral Mating Connector	—		YSC-1	—	
5CN Connector and 1m Cable with Pig-tails	—		DE9404559	Can use 5CN for analog speed and torque monitor service checks.	

* Choose either a straight or L-type connector and the associated cable clamp for a complete assembly. For example, L-type connector MS3108B18-10S is compatible with cable clamp MS3057-10A. MS connectors listed in the table are non-environmental.

400V Three-phase Sigma II Servo Systems

Peripheral Device Selection

Use the table below to select peripheral devices for each SGMGH Sigma II servomotor.

Component (E)	Part Number	Description	Item Class
Hand-held Digital Operator Panel	JUSP-OP02A-1 and JZSP-CMS00-1	Portable unit with 1m adapter cable for Sigma II	Stock
Software Interface Cable	YS-12	Pre-wired 2.0m cable with 9-pin connector	
Absolute Encoder Battery	JZSP-BA01 JZSP-BA01-1	3.6V, 1000mAh (Lithium Battery) For SGDH-60 and above (same as JZSP-BA01 with longer lead)	
SigmaWin+ Software	JZSP-WP0001	Minimum Recommended System Requirements Pentium 200 MHz, 64MB RAM, 200MB hard drive, CDROM Drive, RS-232 or RS-422 port, Screen resolution 800x600 w/ 256 colors, and Windows 95,98,NT4.0,2000,ME. (Windows XP planned)	
Regenerative Unit (880W) for 6.0 and 7.5kW amplifier	JUSP-RA18	These are general purpose regenerative units.	Limited Stock
Regenerative Unit (1760W) for 11 and 15kW amplifiers	JUSP-RA19	Order the Motion document: PI#99004 for setup instructions for this unit. Caution: Proper set-up is necessary to avoid equipment damage.	
DC Reactor (for suppressing harmonics in the power supply)	For 400V: SGDH-05DE	X5074	—
	For 400V: SGDH-10DE SGDH-15DE	X5075	
	For 400V: SGDH-20DE SGDH-30DE	X5076	
	For 400V: SGDH-50DE	X5077	
	Larger capacity amplifiers	Check factory for availability.	—

CE Pre-wired Cable Selection

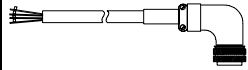

Use the table below to select shielded pre-wired power cables for your SGMGH Sigma II servomotor.

Cable Description (C)		Motor Size (kW)	Part Number*	Comments	Item Class
Power Cable with Connectors (IP67)		0.5, 0.9, 1.3	BACE-□□(A)	Use the following key to specify needed cable length (last two digits of the part number): 03: 3m 05: 5m 10: 10m (standard) 15: 15m 20: 20m	Limited Stock
		2.0, 3.0, 4.4	BBCE-□□(A)		
		5.5, 7.5, 11	BDCE-□□(A)		
		15	B5CE-□□(A)		
Power Cable for Holding Brake (IP67)	All	B7BCE-□□(A)	Limited Stock		

* The "(A)" at the end of the cable number indicates the revision level. The revision level may be subject to change prior to this catalog's reprinting.

CE Connector Selection

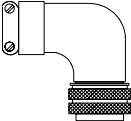
Use the table below to select mating connectors for your SGMGH Sigma II servomotor.

Connector Description (D)		Motor Size (kW)	Part Number	Comments**	Item Class
Connector for Motor Power Cable*		0.5, 0.9, 1.3	CE05-8A18-10SD-B-BAS CE3057-10A-1(D265)	L-type connector Cable clamp (for diameters 0.413 to 0.555in)	Limited Stock
		2.0, 3.0, 4.4	CE05-8A22-22SD-B-BAS CE3057-12A-1(D265)	L-type connector Cable clamp (for diameters 0.492 to 0.630in)	
		5.5, 7.5, 11, 15	CE05-8A32-17SD-B-BAS or CE05-6A32-17SD-B-BSS CE3057-20A-1	L-type connector or Straight-type connector Cable clamp (for diameters 0.866 to 0.937in)	
Connector for Holding Brake	CE05-8A10SL-3SC-B-BAS and CE3057-4A-1 (D265)		L-type connector for holding brake and Cable clamp (for diameters 0.142 to 0.220in)		
Connector for Encoder Cable (incremental or absolute encoder)		All	CE02-6A20-29NSW and CE20BA-S or CE3057-12A-3(D265)	L-type connector (plug and back shell) or Cable clamp (for diameters 0.265 to 0.394in)	

* Choose the connector and the associated cable clamp for a complete assembly. The connectors listed in the table are suitable for IP67 environments.

** Connectors are manufactured by DDK and listed here with the largest standard cable clamp available.

Higher rpm Power Rate Series

SGM_{SH}/U_H Servomotors - With Incremental / Absolute Encoder

Rated Output: 1.0kW, 1.5kW, 2.0kW,
3.0kW, 4.0kW, 5.0kW



For Additional Information	Page(s)
SGM _{SH} /U _H Ratings & Specifications	140
SGM _{SH} /U _H Speed/Torque Curves	141
SGM _{SH} Dimensions	142 - 143
SGM _{UH} Dimensions	144 - 145
SGM _{SH} /U _H Selection/Ordering Information	146 - 150
SGM _{SH} /U _H Optional CE Selection	151
SGDH Ratings & Specifications	167 - 168
SGDH Dimensions	169 - 188

SGM_{SH}/U_H
Servomotors

Design Features

- 1. Compact**
 - Small sized motor
 - Eight frame sizes: up to 422in •lb peak torque
- 2. Higher Speed**
 - Rated Speed: 3000rpm
 - Maximum Speed: Up to 6000rpm (SGM_{UH} only)
- 3. Encoders**
 - 17-bit (32,768 ppr x 4) incremental encoder (standard)
 - 17-bit absolute encoder (option)
- 4. Enclosure**
 - Totally enclosed, self-cooled IP67 (excluding shaft)
 - IP67 with shaft seal (option)
- 5. Application Emphasis**
 - High torque to inertia ratio
 - Chip mounters
 - PCB drilling machines
 - Robots
 - Conveyors
 - Packaging
- 6. Certified International Standards**
 - UL, cUL recognized (File #: E165827), CE compliance

Servomotor Ratings and Specifications

Time Rating:	Continuous	Enclosure:	Totally-enclosed, self-cooled	Maximum Rotational Speed:	
Insulation:	Class F		IP67 (except for shaft opening)		5000, 6000rpm*
Vibration:	15µm or less	Ambient Temperature:	0 to 40°C	Excitation:	Permanent magnet
Withstand Voltage:	1500V _{ac} , 1800V _{ac} *	Ambient Humidity:	20 to 80%	Drive Method:	Direct drive
Insulation Resistance:	10MΩ minimum at 500V _{DC}		(non-condensing)	Mounting:	Flange-mounted
		Rated Speed:	3000rpm, 6000rpm*	Painting Color:	Muncell notation N1.5

* SGMUH models only.

Amplifier Systems Voltage	MOTORS:		Rated Output*	Rated Torque*		Instantaneous Peak Torque*		Rated Current*	Instantaneous Maximum Current*
	Type	Number	kW (hp)	N•m	lb•in (KG•cm)	N•m	lb•in (KG•cm)	A (rms)	A (rms)
400V _{ac}	SGMSSH-	10D□A	1.0 (1.3)	3.18	28.2 (32.4)	9.54	84.4 (97.2)	2.8	8.5
		15D□A	1.5 (2.0)	4.9	43.4 (50)	14.7	130 (150)	4.7	14
		20D□A	2.0 (2.7)	6.36	56.4 (65)	19.1	169 (195)	6.2	19.5
		30D□A	3.0 (4.0)	9.8	87 (100)	29.4	260 (300)	8.9	28
		40D□A	4.0 (5.4)	12.6	112 (129)	37.8	336 (387)	12.74	38.5
		50D□A	5.0 (6.7)	15.8	140 (161)	47.6	422 (486)	14.3	42
	SGMUH-*	10D□A	1.0 (1.3)	1.59	14.1 (16.2)	6.5	57.6 (66.18)	2.7	8.5
		30D□A	3.0 (4.0)	4.9	43.4 (50)	21.5	190 (218.3)	8.1	28

** Only the Sigma II SGMUH models are available with a maximum speed of 6000rpm.

MOTORS:		Torque Constant	Moment of Inertia		Holding Brake (at 20°C)					Allowable Load Inertia	Rated Power Rate*	Rated Angular Acceleration*	Inertia Time Constant	Inductive Time Constant
Type	Number	$\frac{\text{lb}_f \cdot \text{in}}{\text{A}_{\text{rms}}}$	$\text{lb}_f \cdot \text{in} \cdot \text{s}^2 \times 10^{-3}$	$\text{KG} \cdot \text{m}^2 \times 10^{-4}$	Capacity	Torque	Coil Resistance	Rated Current	Additional Inertia					
					W	N•m	W	A	$\text{lb}_f \cdot \text{in} \cdot \text{s}^2 \times 10^{-3}$	$\text{KG} \cdot \text{m}^2 \times 10^{-4}$	kWs	rad/s^2	ms	ms
SGMSSH-	10D□A	11.2	1.54	1.74	7.0	7.84	82.0	0.29	0.219	8.7	57.9	18250	0.97	6.3
	15D□A	10.2	2.19	2.47						12.4	97.2	19840	0.80	6.8
	20D□A	9.9	2.82	3.19						16.0	127	19970	0.66	7.3
	30D□A	10.5	6.20	7.00	9.85	20.0	58.5	0.41	1.89	35.0	137	14000	0.76	16.3
	40D□A	9.38	8.50	9.60						48.0	166	13160	—	—
	50C□A	10.62	10.9	12.3						61.5	202	12780	—	—
SGMUH-	10D□A	7.2	1.54	1.74	—	—	—	—	—	8.7	14.5	9130	0.87	7.1
	30D□A	7.2	6.2	7.0	—	—	—	—	—	35	34.3	7000	0.72	17.3

* These items and torque-speed characteristics quoted in combination with an SGD servo amplifier at an armature winding temperature of 20°C.

Note: These characteristics can be obtained when the following heat sinks (steel plates) are used for cooling purposes:

Type 10D□A to 20D□A: (11.81 × 11.81 × 0.47 (in)) (300 × 300 × 12 (mm))

Type 30D□A to 50D□A: (15.75 × 15.75 × 0.79 (in)) (400 × 400 × 20 (mm))

Speed / Torque Curves

400V

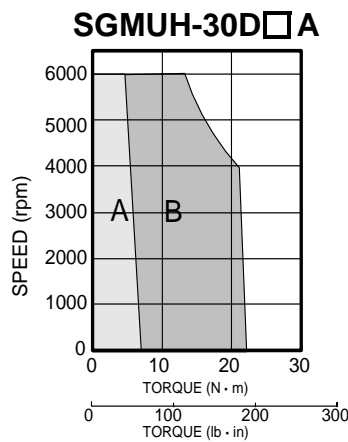
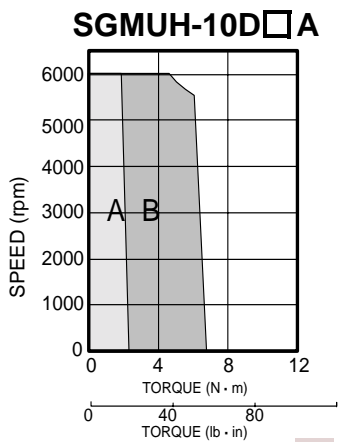
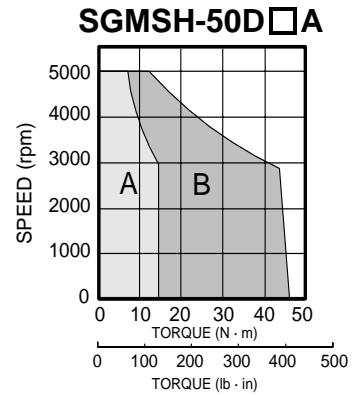
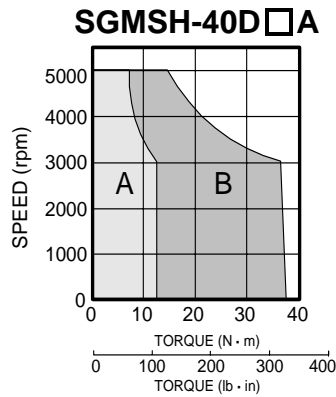
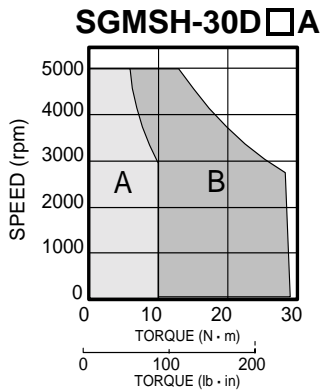
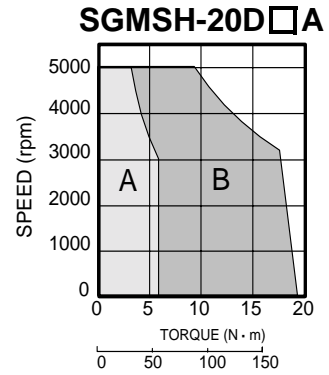
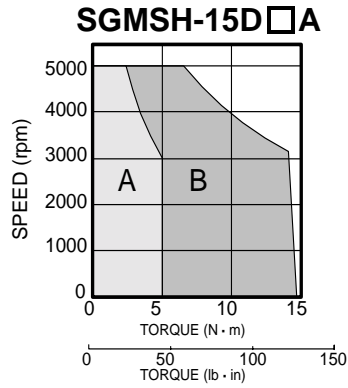
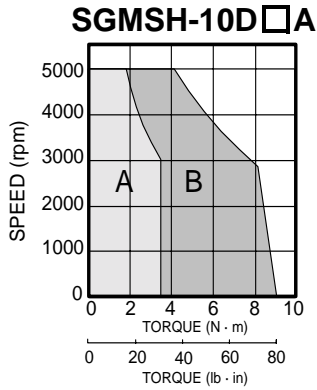

A : CONTINUOUS DUTY ZONE
B : INTERMITTENT DUTY ZONE

400V Three-phase Sigma II Servo Systems

(2) 17-bit Incremental or Absolute Encoder, with Brake

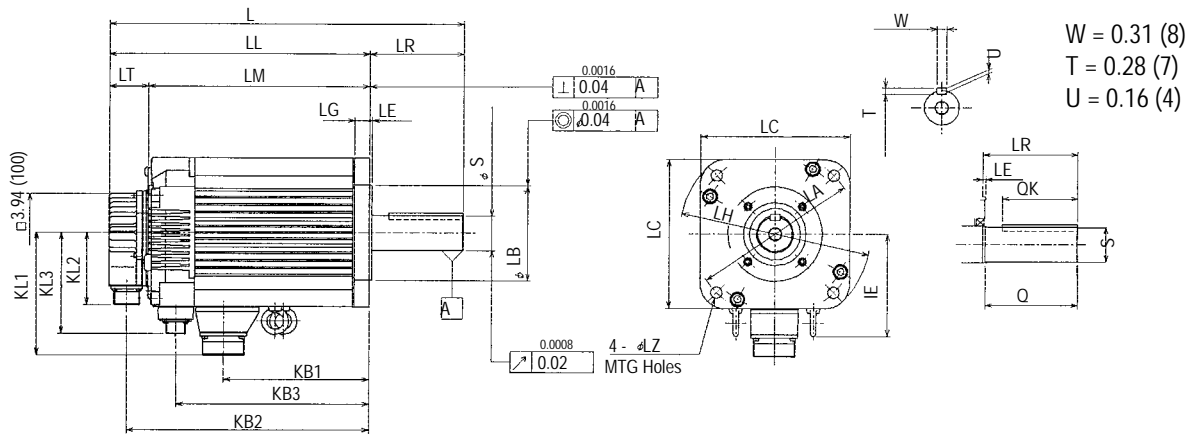

SGMSH
Servomotors

Type SGMSH-	L	LL	LM	LR	LT	KB1	KB2	KB3	KL1	KL2	KL3	Flange Dimensions						Shaft End Dimension			Approximate Mass lb _r (kg)	Allowable Radial Load lb _r (N)	Allowable Thrust Load lb _r (N)													
												ΦLA	ΦLB**	LC	LE	LG	ΦLH	ΦLZ	ΦS*	Q				QK												
10D□A6C	9.37 (238)	7.6 (193)	5.79 (147)	1.77 (45)	1.81 (46)	2.99 (76)	6.77 (172)	4.72 (120)	378 (96)	3.35 (85)	4.53 (115)	3.74 (95)	3.94 (100)	0.12 (3)	0.39 (10)	5.12 (130)	0.28 (7)	0.94 (24)	1.57 (40)	1.26 (32)	13.2 (6.0)	154 (686)	44 (196)													
15D□A6C	10.39 (264)	8.62 (219)	6.81 (173)	1.77 (45)		4.02 (102)	7.80 (198)	5.75 (146)													3.86 (98)			5.71 (145)	4.33 (110)	5.12 (130)	0.24 (6)	0.47 (12)	6.5 (165)	0.35 (9)	1.1 (28)	2.17 (55)	1.96 (50)	16.5 (7.5)		
20D□A6C	11.3 (287)	9.53 (242)	7.72 (196)	1.77 (45)		4.92 (125)	8.7 (221)	6.65 (169)													3.46 (88)			5.71 (145)	4.33 (110)	5.12 (130)	0.24 (6)	0.47 (12)	6.5 (165)	0.35 (9)	1.1 (28)	2.17 (55)	1.96 (50)	18.7 (8.5)		
30D□A6C	11.81 (300)	9.33 (237)	7.52 (191)	2.48 (63)		4.80 (122)	8.50 (216)	6.69 (170)													4.49 (114)			5.71 (145)	4.33 (110)	5.12 (130)	0.24 (6)	0.47 (12)	6.5 (165)	0.35 (9)	1.1 (28)	2.17 (55)	1.96 (50)	30.9 (14)	220 (980)	88 (392)
40D□A6C	13.27 (337)	10.79 (274)	8.98 (228)	2.48 (63)		—	—	—													—			5.71 (145)	4.33 (110)	5.12 (130)	0.24 (6)	0.47 (12)	6.5 (165)	0.35 (9)	1.1 (28)	2.17 (55)	1.96 (50)	37.5 (17)	265 (1176)	
50D□A6C	13.27 (337)	12.36 (314)	10.55 (268)	2.48 (63)	—	—	—	—	5.71 (145)	4.33 (110)	5.12 (130)	0.24 (6)	0.47 (12)	6.5 (165)	0.35 (9)	1.1 (28)	2.17 (55)	1.96 (50)	44.1 (20)																	

Note: 1. Dimensions are the same when using either incremental or absolute encoders (with or without optional shaft seal).
2. Tolerances on the dimensions of flange type LB and of shaft extensions S are based on JIS (Japanese Industrial Standard) B0401 "Limits and Fits for Engineering."

Specified Tolerances					
Dimension	*ΦS		**ΦLB		
	Unit	Diameter	Tolerance	Diameter	Tolerance
	in	0.9449, 1.1024	+0.0000-0.0005	3.7402, 4.3307	+0.0000 -0.0014
	mm	24.000, 28.000	+0.000 -0.013	95.000, 110.000	+0.000 -0.035

Plug for Holding Brake

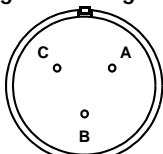

MS3102A10SL-3P

Connector Wiring on the Brake, Motor Side

A	Brake Terminal
B	Brake Terminal
C	—

Non-Environmental Mating Connector:
MS3108A10SL-3S (L Type)
MS3106A10SL-3S (Straight Type)
Cable Clamp: MS3057-4A

Motor Plug

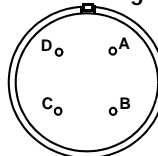

Connector Wiring on the Motor Side

A	U Phase
B	V Phase
C	W Phase
D	Ground Terminal

SGMUH Dimensions in inches (mm)

(1) 17-bit Incremental or Absolute Encoder

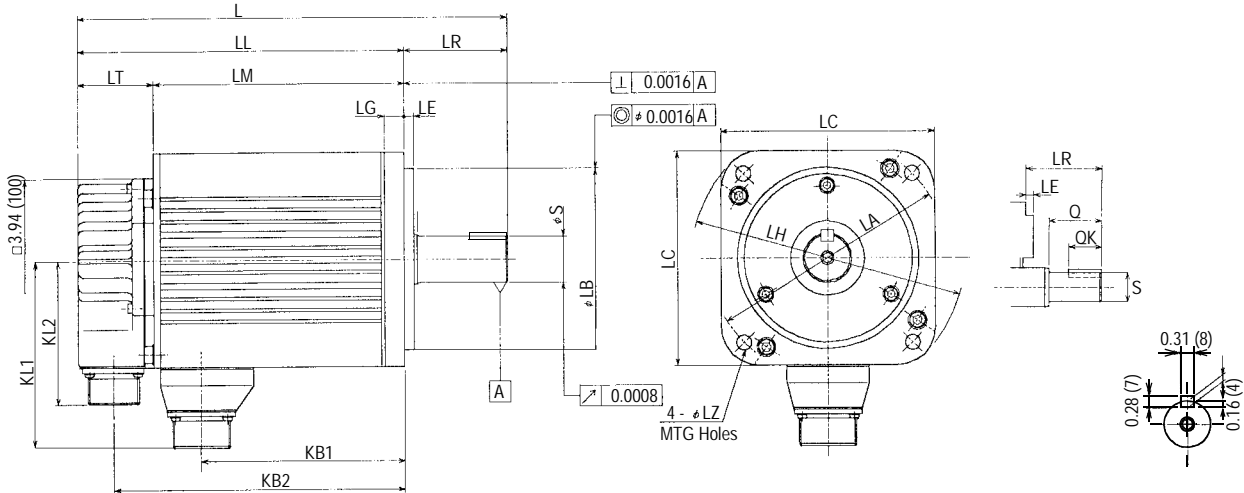

SGMUH Servomotors

Type SGMUH-	L	LL	LM	LR	LT	KB1	KB2	KL1	KL2	Flange Dimensions						Shaft End Dimension			Approximate Mass lb _f (kg)	Allowable Radial Load lb _f (N)	Allowable Thrust Load lb _f (N)	
										ΦLA	ΦLB**	LC	LE	LG	ΦLH	ΦLZ	ΦS*	Q				QK
10D□A61	7.64 (194)	5.87 (149)	4.06 (103)	1.77 (45)	1.81 (46)	2.99 (76)	5.04 (128)	3.78 (96)	3.46 (88)	5.12 (130)	4.33 (110)	4.57 (116)	0.14 (3.5)	0.39 (10)	5.91 (150)	0.35 (9)	0.94 (24)	1.57 (40)	1.26 (32)	10.1 (4.6)	110 (490)	22 (98)
15D□A61	8.66 (220)	6.89 (175)	5.08 (129)			4.02 (102)	6.06 (154)													12.8 (5.8)		
30D□A61	10.31 (262)	7.95 (202)	6.14 (156)	2.36 (60)		5.00 (127)	7.13 (181)	4.49 (114)		6.50 (165)	5.12 (130)	6.10 (155)		0.47 (12)	7.48 (190)	0.43 (11)	1.1 (28)	2.17 (55)	1.96 (50)	24.3 (11)	154 (686)	44.1 (196)

Note: 1. Dimensions are the same when using either incremental or absolute encoders (with or without optional shaft seal).
2. Tolerances on the dimensions of flange type LB and shaft extensions S are based on JIS (Japanese Industrial Standard) B0401 "Limits and Fits for Engineering."

Specified Tolerances				
Dimension	*ΦS		**ΦLB	
Unit	Diameter	Tolerance	Diameter	Tolerance
in	0.9449, 1.1024	+0.0000-0.0005	4.3307	+0.0005 -0.00035
			5.12	+0.00055 -0.00043
mm	24.000, 28.000	+0.000 -0.013	110.000	+0.013 -0.009
			130	+0.014 -0.011

Encoder Plug

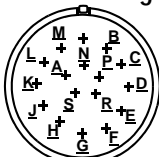

MS3102A20-29P

Connector Wiring on the Incremental Encoders			
A	—	K	—
B	—	L	—
C	Data +	M	—
D	Data -	N	—
E	—	P	—
F	—	R	—
G	0V	S	Battery - (Note*)
H	+5V _{dc}	T	Battery + (Note*)
J	FG (Frame Ground)		*Note: Used with an absolute encoder only.

Non-Environmental Mating Connector:
MS3108B20-29S (L Type)
MS3106B20-29S (Straight Type)
Cable Clamp: MS3057-12A

Motor Plug

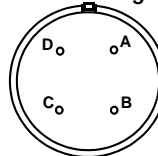

Connector Wiring on the Motor Side	
A	U Phase
B	V Phase
C	W Phase
D	Ground Terminal

(2) 17-bit Incremental or Absolute Encoder, with Brake

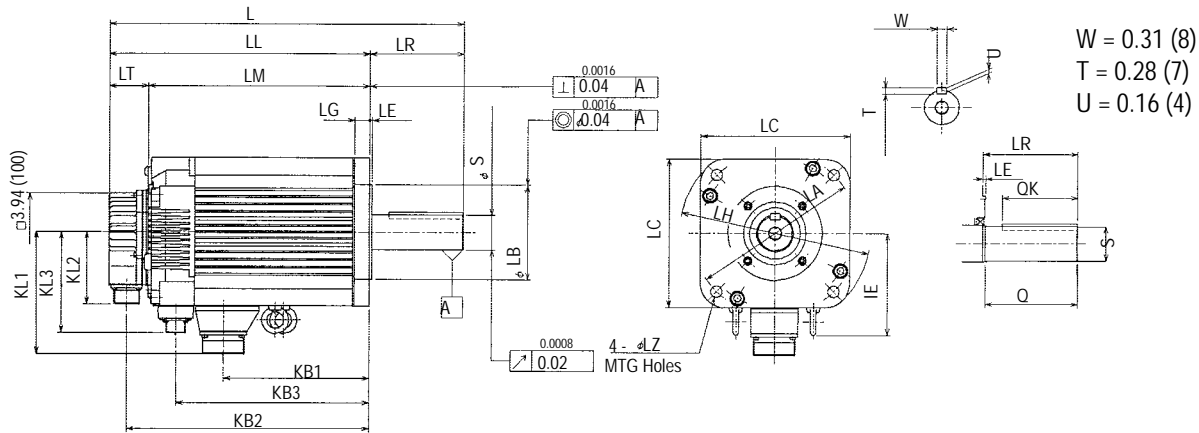

SGMUH
Servomotors

Type SGMUH-	L	LL	LM	LR	LT	KB1	KB2	KB3	KL1	KL2	KL3	Flange Dimensions						Shaft End Dimension			Approximate Mass lb _f (kg)	Allowable Radial Load lb _f (N)	Allowable Thrust Load lb _f (N)			
												ΦLA	ΦLB**	LC	LE	LG	ΦLH	ΦLZ	ΦS*	Q				OK		
10D□A6C	9.37 (238)	7.6 (193)	5.79 (147)	1.77 (45)	1.81 (46)	2.99 (76)	6.77 (172)	4.72 (120)	3.78 (96)	3.46 (88)	3.35 (85)	5.12 (130)	4.33 (110)	4.57 (116)	0.14 (3.5)	0.39 (10)	5.91 (150)	0.35 (9)	0.94 (24)	1.57 (40)	1.26 (32)	13.2 (6.0)	110 (490)	22 (98)		
15D□A6C	10.39 (264)	8.62 (219)	6.81 (173)			4.02 (102)	7.80 (198)	5.75 (146)				3.86 (98)	6.50 (165)	5.12 (130)	6.10 (155)	0.24 (6)	0.47 (12)	7.48 (190)	0.43 (11)	1.1 (28)	2.17 (55)				1.96 (50)	16.5 (7.5)
30D□A6C	11.81 (300)	9.33 (237)	7.52 (191)			4.80 (122)	8.50 (216)	6.69 (170)				4.49 (114)	6.50 (165)	5.12 (130)	6.10 (155)	0.24 (6)	0.47 (12)	7.48 (190)	0.43 (11)	1.1 (28)	2.17 (55)				1.96 (50)	30.9 (14)

Note: 1. Dimensions are the same when using either incremental or absolute encoders (with or without optional shaft seal).
2. Tolerances on the dimensions of flange type LB and of shaft extensions S are based on JIS (Japanese Industrial Standard) B0401 "Limits and Fits for Engineering."

Specified Tolerances				
Dimension	*ΦS		**ΦLB	
Unit	Diameter	Tolerance	Diameter	Tolerance
in	0.9449, 1.1024	+0.0000-0.0005	4.3307	+0.0005 -0.00035
			5.12	+0.00055 -0.00043
mm	24.000, 28.000	+0.000 -0.013	110.000	+0.013 -0.009
			130	+0.014 -0.011

Plug for Holding Brake

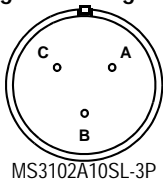

Connector Wiring on the Brake, Motor Side	
A	Brake Terminal
B	Brake Terminal
C	—

Non-Environmental Mating Connector:
MS3108A10SL-3S (L Type)
MS3106A10SL-3S (Straight Type)
Cable Clamp: MS3057-4A

Motor Plug

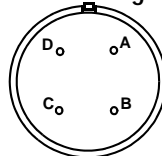

Connector Wiring on the Motor Side	
A	U Phase
B	V Phase
C	W Phase
D	Ground Terminal

Selecting Your SGMSH/UH Sigma II Servo System

First, select the Sigma II servomotor suited for your application using SigmaSize: the Yaskawa servomotor sizing software, available at no charge. (Request SigmaSize software via e-mail, at: literature@yaskawa.com).

Use the diagram below to locate and identify the components of your system. Each item is letter-coded and cross-referenced in the option tables on the following pages.

System Configuration

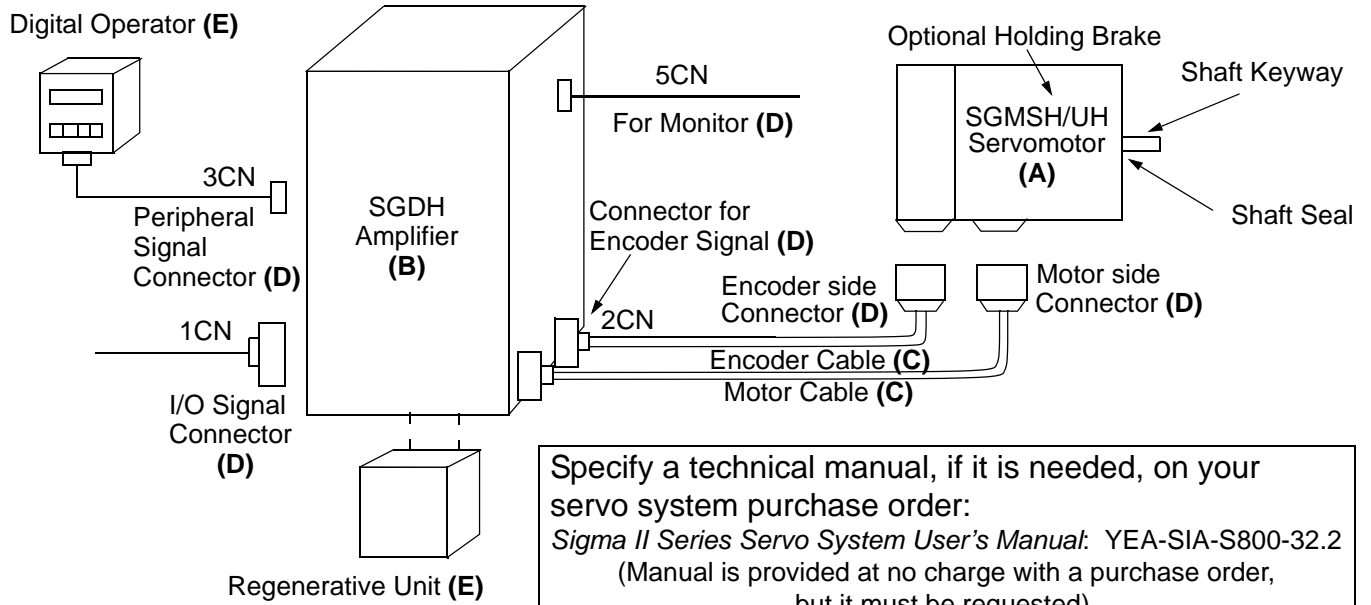

SGMSH/UH Servomotors

Model Number Designation

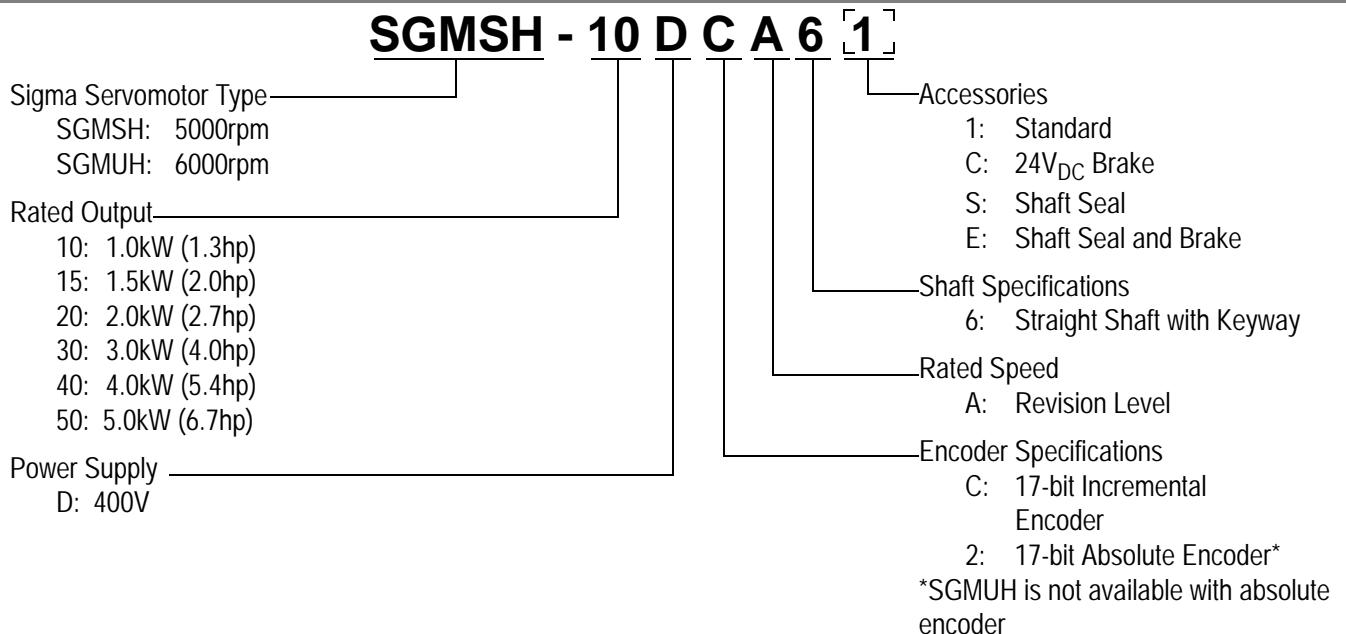

400V Three-phase Sigma II Servo Systems

Servomotor & Amplifier Selection

Use the table below to select the appropriate SGMSH or SGMUH Sigma II servomotor and amplifier. (Refer to the motor model # designation on the previous page specifying the available modification to motor construction/features.)

Description	Peak Torque (in • lb)	Rated Torque (in • lb)	Motor Inertia (in • lb • s ² X 10 ⁻³)	Motor MODEL # (A)	Amplifier MODEL # (B)* Analog/Digital Input SGDH-	Motor and Amplifier Item Class
400V, Three-Phase 17-bit Incremental Encoder Straight Shaft with Keyway 5000rpm maximum MS Connectors	84.4	28.2	1.54	SGMSH-10DCA61	10DE	Stock
			1.76	SGMSH-10DCA6C		
	130	43	2.19	SGMSH-15DCA61	15DE	
			2.41	SGMSH-15DCA6C		
	169	56.4	2.82	SGMSH-20DCA61	20DE	
			3.04	SGMSH-20DCA6C		
	260	87	6.2	SGMSH-30DCA61	30DE	
			8.1	SGMSH-30DCA6C		
	336	112	8.5	SGMSH-40DCA61	50DE	
			10.4	SGMSH-40DCA6C		
10.9			SGMSH-50DCA61			
12.8			SGMSH-50DCA6C			
422	140					
400V, Three-Phase 17-bit Incremental Encoder Straight Shaft with Keyway 6000rpm maximum MS Connectors	57.6	14.1	1.54	SGMUH-10DCA61	10DE	
190	43.4	6.2	SGMUH-30DCA61	30DE		

SGMSH/UH
Servomotors

Note: 24V_{DC} brakes for SGMUH and SGMSH Sigma II servomotors are standard. Contact a local source for 24V_{DC} power supplies. For technical information, request Yaskawa manual number YEA-SIA-S800-32.2.

* For more detailed SGD amplifier specifications and dimensions, refer to pages 167 - 188.

Pre-wired Cable Selection

Use the table below to select pre-wired cables for your SGMSH/UH-Series Sigma II servomotor.

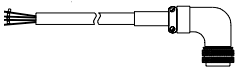
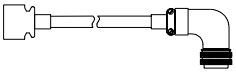
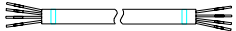
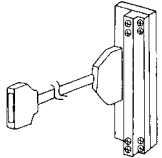
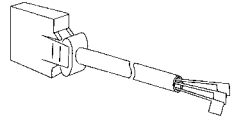
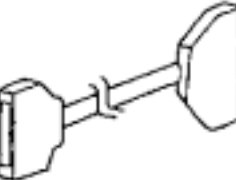
Cable Description (C)		Motor Size (kW)	Part Number*	Comments	Item Class
Power Cable with L-type Connectors (IP67)		1.0, 1.5, 2.0	BAE-□□(A)	Use the following key to specify needed cable length (last two digits of the part number): 03: 3m 05: 5m 10: 10m (standard) 15: 15m 20: 20m	
		3.0 4.0, 5.0	BBE-□□(A)		
Cable with Holding Brake (IP67)		1.0, 1.5 2.0, 3.0 4.0, 5.0	B7BCE-□□(A)		
Encoder Cable (incremental or absolute) (IP67)		All	JZSP-CMP02-□□(B)	These cables are available in five lengths. Use two digits in the part number's last place: 03: 3m 05: 5m 10: 10m (standard) 15: 15m 20: 20m	Stock**
Encoder Cable (for applications up to 20m) Only for Solder Connections			FR-RMCT-SB	These cables are available in any length.	
Encoder Cable (for applications from >20 to <50m) Only for Solder Connections			UL20276-SB	For example, to order one FR-RMCT-SB cable, 16m long, specify: quantity: 16 part no.: FR-RMCT-SB	
Input/Output 1CN Cable & Transition Terminal Block			JUSP-TA50P	35mm DIN rail mountable; the cable length is 0.5m.	
Input/Output 1CN Cable with Pigtail Leads			JZSP-CKI01-□(A)	Use the following key to specify required cable length (last digit of part number): 1: 1m (standard) 2: 2m 3: 3m	
Input/Output 1CN Cable with Female D-Sub output Connector***			JZSP-CKI0D-□□	Use the following key to specify required cable length (last two digits of the part number): D50: 0.5m 01: 1m (standard) 02: 2m 03: 3m	



* "(A)" at the end of the cable number is the revision level. The revision level may be changed prior to this catalog's reprinting.

** Standard cable lengths are Stock items; non-standard cable lengths are Limited Stock items.

*** 50 Pin Female D-Sub output connector mates to customer supplied third party terminal block. (e.g., Wago #289-449, Weidmuller #919658, Phoenix #2283647, Amphenol/Sine #20-51039, and many others).

Connector Selection

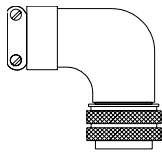
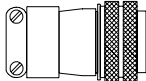
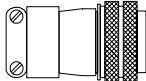
Use the table below to select mating connectors for your SGMSH/UH Sigma II servomotor.

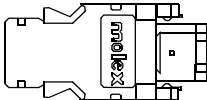
Connector Description (D)		Motor Size (kW)	Part Number	Comments	Item Class	
MS Connector for Motor Power Cable*		1.0, 1.5, 2.0	MS3106B18-10S	Straight-type connector	Stock	
			MS3108B18-10S	L-type connector		
			MS3057-10A	Cable clamp		
		3.0, 4.0, 5.0	MS3106B22-22S	Straight-type connector		
			MS3108B22-22S	L-type connector		
			MS3057-12A	Cable clamp		
MS Connector for Brake Power Cable		All	MS3108A-10SL-3S	L-type connector		
MS3057-4A			Cable clamp			
MS Connector for Encoder Cable (incremental or absolute encoder)			All	MS3106B20-29S		Straight-type connector
				MS3108B20-29S		L-type connector
		MS3057-12A		Cable clamp		
1CN Mating Connector				JZSP-CKI9		—
2CN Encoder Mating Connector		JZSP-CMP9-1		—		
3CN Peripheral Mating Connector	—	YSC-1		—		
5CN Connector and 1m Cable with Pig-tails	—	DE9404559		—		

SGMSH/UH
Servomotors

* Choose either a straight or L-type connector and the associated cable clamp for a complete assembly. For example, L-type connector MS3108B18-10S is compatible with cable clamp MS3057-10A. MS connectors listed in the table are non-environmental.

Peripheral Device Selection

Use the table below to select peripheral devices for your SGMSH/UH Sigma II servomotor.

Component (E)	Part Number	Description	Item Class
Hand-held Digital Operator Panel	JUSP-OP02A-1 and JZSP-CMS00-1	Portable unit with adapter cable for Sigma II	Stock
Absolute Encoder Battery	JZSP-BA01	3.6V, 1000mAh (lithium battery)	
SigmaWin+ Software	JZSP-WP0001	Minimum Recommended System Requirements Pentium 200 MHz, 64MB RAM, 200MB hard drive, CDROM Drive, RS-232 or RS-422 port, Screen resolution 800x600 w/ 256 colors, and Windows 95,98,NT4.0,2000,ME. (Windows XP planned)	
Software Interface Cable	YS-12	Pre-wired 2.0m cable with 9-pin connector	
External Regenerative Unit (Optional)	JUSP-RA04	These are general purpose regenerative units. Order the Motion document: PI#99004 for setup instructions for this unit. Caution: Proper set-up is necessary to avoid equipment damage.	
DC Reactor (for suppressing harmonics in the power supply)	SGDH-10DE SGDH-15DE SGDH-20DE SGDH-30DE	X5075 X5076	
Large Capacity Amplifiers	Check factory for availability	—	Limited Stock

CE Pre-wired Cable Selection

Use the table below to select shielded pre-wired cables for your SGMSH/UH Sigma II servomotor. These are suitable for IP67 environments.

Use the standard encoder cable listed on page 148.

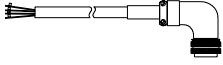
Cable Description (C)		Motor Size (kW)	Part Number*	Comments	Item Class
Power Cable with Connectors (IP67)		1.0, 1.5, 2.0	BACE-□□(A)	Use the following key to specify needed cable length (last two digits of the part number): 03: 3m 05: 5m 10: 10m (standard) 15: 15m 20: 20m	Limited Stock
		3.0, 4.0, 5.0	BBCE-□□(A)		
Power Cable for Holding Brake (IP67)		All	B7BCE-□□(A)		

* The "(A)" at the end of the cable number indicates the revision level. The revision level may be subject to change prior to this catalog's reprinting.

CE/IP67 Connector Selection

Use the table below to select mating connectors for your SGMSH/UH Sigma II servomotor.

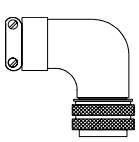
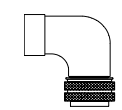
Connector Description (D)		Motor Size (kW)	Part Number	Comments**	Item Class
Connector for Motor Power Cable*		1.0, 1.5, 2.0	CE05-8A18-10SD-B-BAS CE3057-10A-1(D265)	L-type connector Cable clamp (for diameters 0.413 to 0.555in)	Limited Stock
		3.0, 4.0, 5.0	CE05-8A22-22SD-B-BAS CE3057-12A-1(D265)	L-type connector Cable clamp (for diameters 0.492 to 0.630in)	
Connector for Holding Brake		All	CE05-8A10SL-3SC-B-BAS and CE3057-4A-1 (D265)	L-type connector for holding brake Cable clamp (for diameters 0.142 to 0.220in)	
Connector for Encoder Cable (incremental or absolute encoder)			CE02-6A20-29NSW and CE20BA-S CE3057-12A-3(D265)	L-type connector (plug and back shell) Cable clamp (for diameters 0.265 to 0.394in)	

* Choose the connector and the associated cable clamp for a complete assembly. The connectors listed in the table are suitable for IP67 environments.

** Connectors are manufactured by DDK and listed here with the largest standard cable clamp available.

NOTES:

General Purpose

Large Capacity Servomotors (1500rpm) -With

Incremental / Absolute Encoder

Rated Output: 22kW, 30kW, 37kW,
45kW, and 55kW

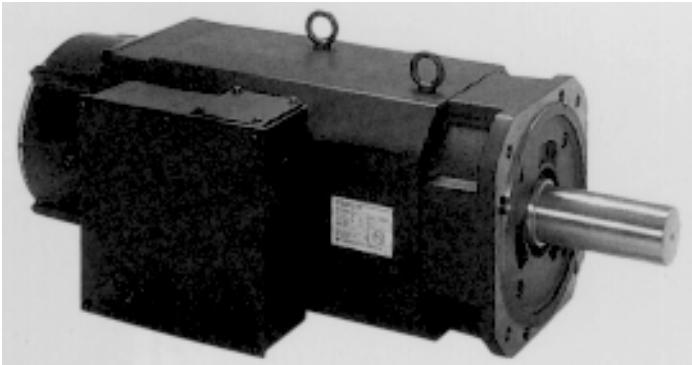

For Additional Information	Page(s)
SGMBH Ratings & Specifications	154
SGMBH Speed/Torque Curves	155
SGMBH Dimensions	156 -159
SGMBH Selection/Ordering Information	160 -164
SGDH Ratings & Specifications	167 -168
SGDH Dimensions	169 -188

Design Features

1. Compact Size

- Smaller sized motor
 - Five types of rated outputs ranging from 2480 to 6120in-lb of peak torque
 - Optional built-in holding brake available
- Brushless Permanent Magnet (PM) design
 - Smaller size
 - Lower rotor inertia
 - Neodymium Internal Permanent Magnet (IPM) construction

2. Lower Maintenance Requirements

- Clean, energy-efficient replacement for hydraulic power systems
- Quieter, cleaner operation (no noisy pumps or leaky hoses)

3. Higher Speed and Acceleration

- Up to 2000rpm (maximum)
- High torque to inertia ratio

4. Rugged, Industrially-Designed Feedback

- 17-Bit (32,768 ppr x 4) incremental encoder (standard)
- 17-Bit absolute encoder (optional)

5. Enhanced Environmental Resistance

- Totally enclosed, self-cooled IP44 (including shaft)
- Shaft seal (optional)

6. Application Emphasis

- Machine tools
- Packaging machines
- Press Automation
- Thermoforming
- All-Electric Injection Molding Machines

7. •UL, cUL recognized (File #: E165827), CE compliance

Servomotor Ratings and Specifications

Time Rating:	Continuous	Enclosure:	Totally-enclosed, self-cooled	Instantaneous Maximum Speed*:	2000rpm
Insulation:	Class F		IP44 (including shaft)	Excitation:	Permanent magnet
Vibration:	15 μ m or less	Ambient Temperature:	0 to 40°C	Drive Method:	Direct drive
Withstand Voltage:	1500V _{ac}	Ambient Humidity:	20 to 80%	Mounting:	Flange-mounted
Insulation Resistance:	500V _{dc}	(non-condensing)			Foot Mount (55kW only)
	10M Ω or more	Rated Speed*:	1500rpm	Thermal Protection:	Built-in

MOTORS: SGMBH--	Rated Output*	Rated Torque*		Instantaneous Peak Torque*		Rated Current*	Instantaneous Maximum Current*
	kW (hp)	N · m	lb _f · in (KG · cm)	N · m	lb _f · in (KG · cm)	A _{rms}	A _{rms}
2BD A	22 (30)	140	1240 (1430)	280	2480 (2855)	58	120
3ZD A	30 (40)	191	1690 (1947)	382	3380 (3895)	80	170
3GD A	37 (50)	236	2090 (2400)	471	4170 (4803)	100	210
4ED A	45 (60)	286	2530 (2920)	572	5060 (5837)	127	260
5ED A	55 (74)	350	3100 (3570)	700	6120 (7143)	150	310

MOTORS SGMBH-	Torque Constant	Moment of Inertia		24VDC Holding Brake			Allowable Load Inertia	Rated Power Rate*	Rated Angular Acceleration*	Inertia Time Constant	Inductive Time Constant
				Torque	Additional Inertia	Watts					
	$\frac{\text{lb}_f \cdot \text{in}}{\text{A}_{\text{rms}}}$ $\left(\frac{\text{N} \cdot \text{m}}{\text{A}_{\text{rms}}}\right)$	$\text{lb} \cdot \text{in} \cdot \text{s}^2 \times 10^{-3}$	$\text{kg} \cdot \text{m}^2 \times 10^{-4}$	$\text{lb}_f \cdot \text{in} \times 10^{-3}$	$\text{in} \cdot \text{lb}_f \cdot \text{s}^2 \times 10^{-3}$		$\text{kg} \cdot \text{m}^2 \times 10^{-4}$	kW/s	rad/s^2	ms	ms
2BD A	22.1 (2.50)	525	592	2106	604	54	2960	331	2360	2.6	53
3ZD A	21.2 (2.39)	685	773	2106	604	54	3865	472	2470	2.3	57
3GD A	21.8 (2.46)	1230	1390	—	—	—	6950	401	1700	3.6	67
4ED A	21.0 (2.37)	1336	1510	—	—	—	8400	542	1890	2.8	72
5ED A	21.2 (2.40)	1750	1970	—	—	—	9850	622	1780	2.7	78

* These specifications and torque-speed characteristics are quoted with the motor used in combination with an SGDH servo amplifier at an armature winding temperature of 20°C.

Note: These characteristics can be obtained when the following heat sinks (steel plates) are used for cooling purposes:

Type 2BD□A to 3ZD□A: 25.59 × 25.59 × 1.38 (in) (650 × 650 × 35 (mm))

Type 3GD□A to 5ED□A: 29.53 × 29.53 × 1.38 (in) (750 × 750 × 45 (mm))

Speed / Torque Curves

SGMBH 400V Servomotors

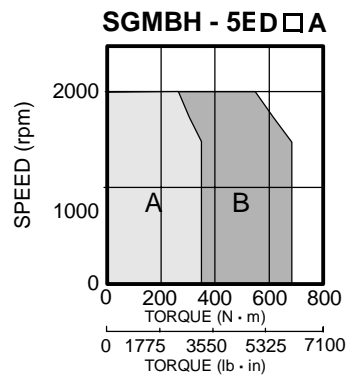
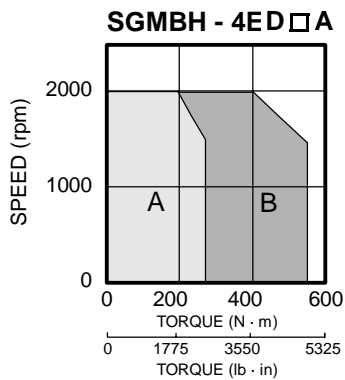
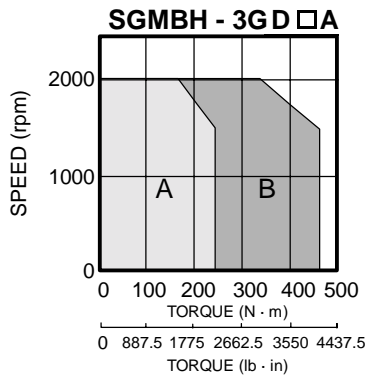
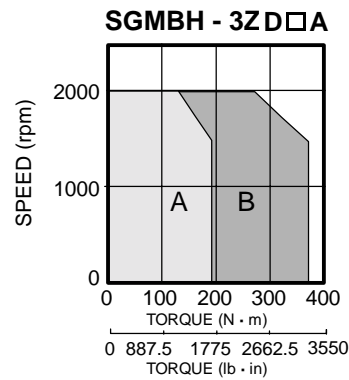
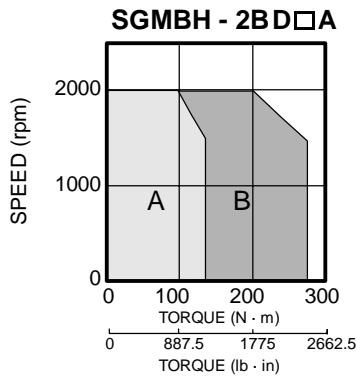

A : CONTINUOUS DUTY ZONE

B : INTERMITTENT DUTY ZONE

Dimensions in inches (mm)

(1) 17 Bit Incremental / Absolute Encoder

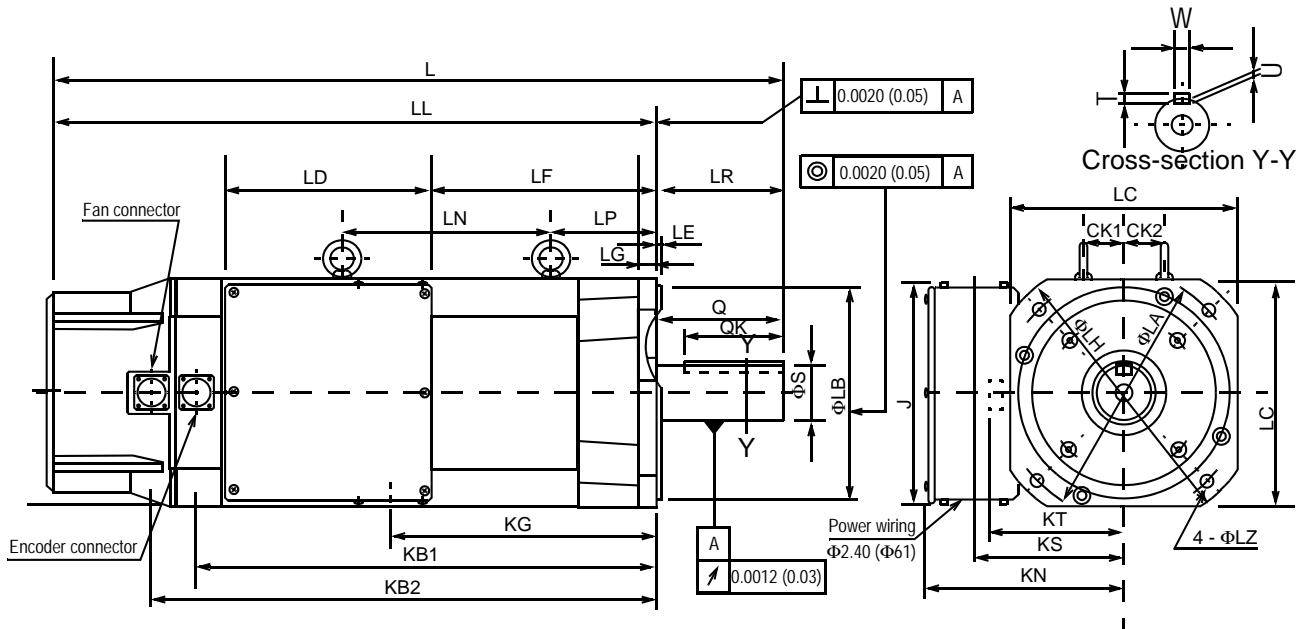

Type SGBMH	Motor Body Dimensions														Flange Dimensions				Shaft End Dimension										
	L	LL	LR	LD	LF	LN	LP	KB1	KB2	KG	KN	KS	KT	CK1	CK2	J	ΦLA	ΦLB**	LC	LE	LG	ΦLH	ΦLZ	ΦS*	Q	QK	W****	T***	U
2BD A61	29.13 (740)	23.62 (600)	5.51 (140)	9.06 (230)	6.97 (177)	6.30 (160)	4.57 (116)	17.17 (436)	19.06 (484)	8.82 (224)	8.66 (220)	6.42 (163)	5.87 (149)	1.77 (45)	1.77 (45)	9.84 (250)	10.43 (265)	9.06 (230)	9.84 (250)	0.20 (5)	0.79 (20)	11.81 (300)	0.53 (13.5)	2.36 (60)	5.51 (140)	4.33 (110)	0.71 (18)	0.43 (11)	0.28 (7)
3ZD A61	31.91 (810)	26.38 (670)			9.65 (245)	9.06 (230)		19.86 (504)	21.75 (552)	11.50 (292)																			

Type SGBMH-	Approximate Mass lb (kg)	Allowable Radial Load lb (N)	Allowable Thrust Load lb (N)
2BD A61	264.5 (120)	1323 (5880)	485 (2156)
3ZD A61	308.7 (140)	1410 (6272)	

Specified Tolerances									
Dimension	*ΦS		**ΦLB		***T		****W		
	Unit	Diameter	Tolerance	Diameter	Tolerance	Length	Tolerance	Length	Tolerance
	in	2.362	+0.00118 -0.00043	9.055	+0.0000 -0.00181	0.433	+0.0000 -0.00043	0.709	+0.0000 -0.00169
	mm	60	+0.030 -0.011	230	+0.000 -0.046	11	+0.000 -0.1103	18	+0.000 -0.043

Note: 1. Dimensions are the same when using either incremental or absolute encoders (with or without optional shaft seal).
 2. Tolerances on the dimensions of flange type LB, of shaft extensions S, and of keyway width and depth are based on JIS (Japanese Industrial Standard) B0401 "Limits and Fits for Engineering."

Encoder Plug

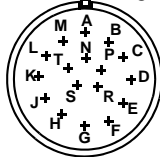

Connector Wiring on the Encoders			
A	—	K	—
B	—	L	—
C	Data +	M	—
D	Data -	N	—
E	—	P	—
F	—	R	—
G	0V	S	Battery - (Note*)
H	+5V _{dc}	T	Battery + (Note*)
J	FG (Frame Ground)		

*Note: Used with an absolute encoder only.

Non-Environmental Mating Connector:
 MS3108B20-29S (L Type)
 MS3106B20-29S (Straight Type)
 Cable Clamp: MS3057-12A

Fan Connector

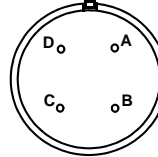

Fan Connector	
A	U Phase
B	V Phase
C	W Phase
D	—

Receptacle: CE05-2A18-10PD-B
 Non-environmental mating connector:
 MS3108B18-10S (L-Type)
 Cable Clamp: MS3057-10A

Power Wiring Terminal Box

Terminal	Connection	Screw Size
U, V, W	Motor	M10
⊕	Ground	

400V Large Capacity Sigma II Servo System

(2) 17 Bit Incremental/Absolute Encoder, with Brake

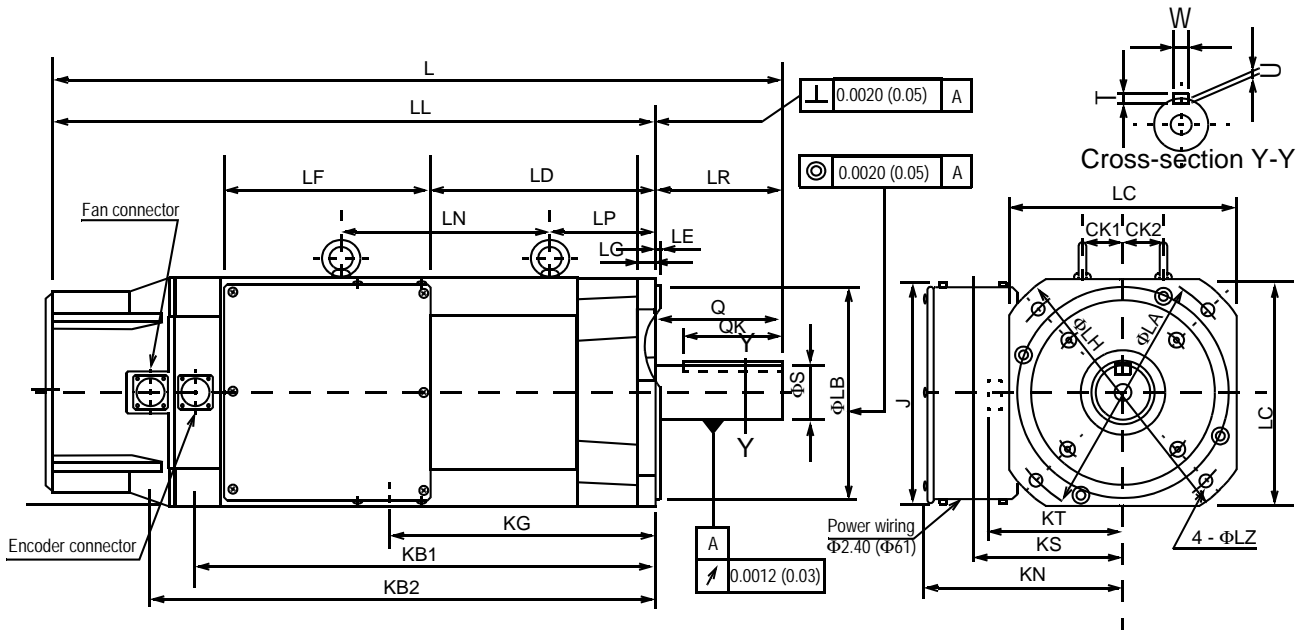

Type SGMBH-	Motor Body Dimensions														Flange Dimensions						Shaft End Dimension								
	L	LL	LR	LD	LF	LN	LP	KB1	KB2	KG	KN	KS	KT	CK1	CK2	J	ΦLA	ΦLB**	LC	LE	LG	ΦLH	ΦLZ	ΦS*	Q	QK	W****	T***	U
2BD A6C	33.86 (860)	28.35 (720)	5.51 (140)	6.97 (177)	9.06 (230)	15.47 (393)	4.57 (116)	21.89 (556)	23.78 (604)	8.82 (224)	8.66 (220)	6.42 (163)	5.87 (149)	1.77 (45)	0.98 (25)	9.84 (250)	10.43 (265)	9.06 (230)	9.84 (250)	0.20 (5)	0.79 (20)	11.81 (300)	0.53 (13.5)	2.36 (60)	5.51 (140)	4.33 (110)	0.71 (18)	0.43 (11)	0.28 (7)
3ZD A6C	36.64 (930)	31.13 (790)		9.65 (245)		18.16 (461)		24.57 (624)	26.46 (672)	11.5 (292)																			

Type SGMBH-	Approximate Mass lb (kg)	Allowable Radial Load lb (N)	Allowable Thrust Load lb (N)	Specified Tolerances								
				*ΦS		**ΦLB		***T		****W		
Dimension	Unit	Diameter	Tolerance	Diameter	Tolerance	Length	Tolerance	Length	Tolerance			
2BD A6C	331 (150)	1323 (5880)	485 (2156)	in	2.362	+0.00118 -0.00043	9.055	+0.0000 -0.00181	0.433	+0.0000 -0.00043	0.709	+0.0000 -0.00169
3ZAD A6C	375 (170)	1410 (6272)		mm	60	+0.030 -0.011	230	+0.000 -0.046	11	+0.000 -0.1103	18	+0.000 -0.043

- Note:
- Dimensions are the same when using either incremental or absolute encoders (with or without optional shaft seal).
 - Tolerances on the dimensions of flange type LB, of shaft extensions S, and of keyway width and depth are based on JIS (Japanese Industrial Standard) B0401 "Limits and Fits for Engineering."

Power Wiring Terminal Box		
Terminal	Connection	Screw Size
U, V, W	Motor	M10
	Ground	
A, B	Brake	M4

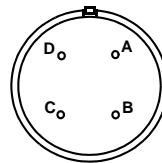

Fan Connector	
A	U Phase
B	V Phase
C	W Phase
D	Ground Terminal

Receptacle: CE05-2A18-10PD-B
 Non-environmental mating connector:
 MS3108B18-10S (L-Type)
 Cable Clamp: MS3057-10A

400V Large Capacity Sigma II Servo System

(3) 17 Bit Incremental/Absolute Encoder

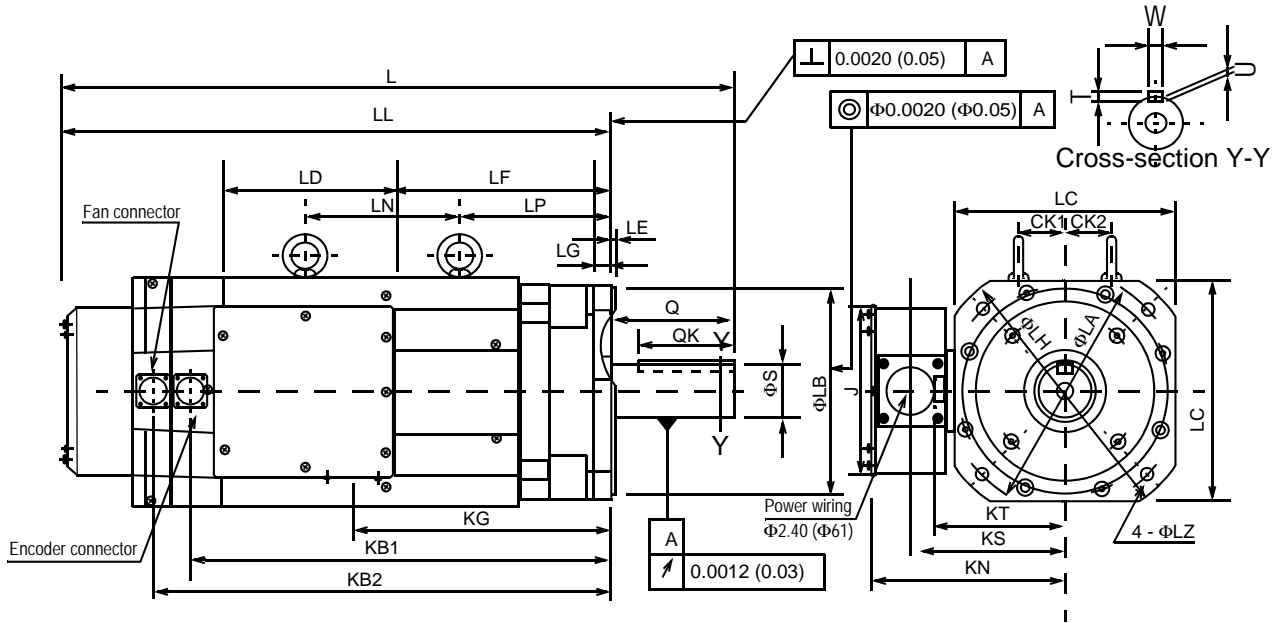

Type SGMBH-	Motor Body Dimensions														Flange Dimensions					Shaft End Dimension								
	L	LL	LD	LF	LN	LP	KB1	KB2	KG	KN	KS	KT	CK1	CK2	J	φLA	φLB**	LC	LE	LG	φLH	φLZ	φS*	Q	QK	W****	T***	U
3GD A61	32.0 (814)	26.5 (674)	9.29 (236)	9.45 (240)	5.91 (150)	7.87 (200)	20.1 (510)	22.0 (558)	11.6 (295)	8.66 (220)	7.91 (201)	6.85 (174)	2.36 (60)	2.36 (60)	8.66 (220)	11.8 (300)	9.84 (250)	11.8 (300)	0.20 (5)	1.38 (35)	13.8 (350)	0.69 (17.5)	2.76 (70)	5.51 (140)	4.33 (110)	0.79 (20)	0.47 (12)	0.29 (7.5)
4ED A61	33.7 (855)	28.1 (715)		11.1 (281)	7.87 (200)	21.7 (551)	23.6 (599)	13.2 (336)																				

Type SGMBH-	Approximate Mass lb (kg)	Allowable Radial Load lb (N)	Allowable Thrust Load lb (N)
3GD A61	507.1 (230)	1674 (7448)	485 (2156)
4ED A61	551.1 (250)	1762 (7840)	

Dimension	Specified Tolerances								
	*φS		**φLB		***T		****W		
	Unit	Diameter	Tolerance	Diameter	Tolerance	Length	Tolerance	Length	Tolerance
in	2.76	+0.0012	-0.004	9.84	+0.0000 -0.0018	0.47	+0.0000 -0.00433	0.79	+0.0000 -0.00204
mm	70	+0.030	+0.011	250	+0.000 -0.046	12	+0.000 -0.110	20	+0.000 -0.052

- Note:
- Dimensions are the same when using either incremental or absolute encoders (with or without optional shaft seal).
 - Tolerances on the dimensions of flange type LB, of shaft extensions S, and of keyway width and depth are based on JIS (Japanese Industrial Standard) B0401 "Limits and Fits for Engineering."

Encoder Plug

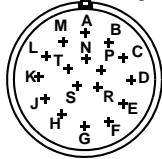

Connector Wiring on the Encoders			
A	—	K	—
B	—	L	—
C	Data +	M	—
D	Data -	N	—
E	—	P	—
F	—	R	—
G	0V	S	Battery - (Note*)
H	+5V _{dc}	T	Battery + (Note*)
J	FG (Frame Ground)		

Non-Environmental Mating Connector:
MS3108B20-29S (L Type)
MS3106B20-29S (Straight Type)
Cable Clamp: MS3057-12A

Fan Connector

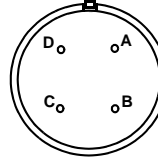

Fan Connector	
A	U Phase
B	V Phase
C	W Phase
D	—

Receptacle: CE05-2A18-10PD-B

Non-environmental mating connector:

MS3108B18-10S (L-Type)

Cable Clamp: MS3057-10A

Power Wiring Terminal Box

Terminal	Connection	Screw Size
U, V, W	Motor	M10
	Ground	

400V Large Capacity Sigma II Servo System

(4) 17 Bit Incremental/Absolute Encoder

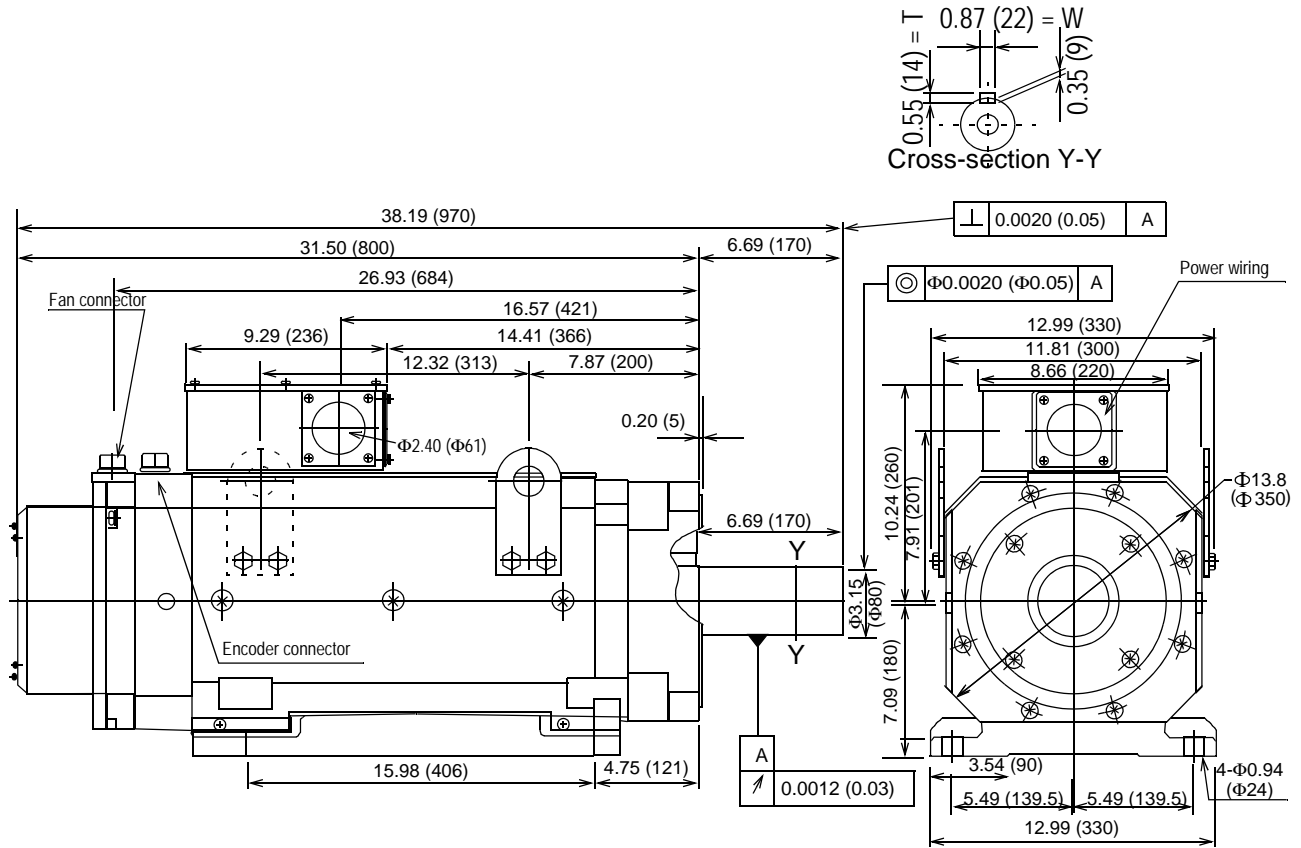

Type SGBMH	Approximate Mass lb (kg)	Allowable Radial Load lb (N)	Allowable Thrust Load lb (N)
5ED AL1	772 (350)	1895 (8428)	485 (2156)

- Note:
- Dimensions are the same when using either incremental or absolute encoders (with or without optional shaft seal).
 - Tolerances on the dimensions of flange type LB, of shaft extensions S, and of keyway width and depth are based on JIS (Japanese Industrial Standard) B0401 "Limits and Fits for Engineering."

Dimension	Specified Tolerances			
		*T		*W
Unit	Length	Tolerance	Length	Tolerance
in	0.55	+0.0000 -0.00433	0.87	+0.0000 -0.00204
mm	14	+0.000 -0.110	22	+0.000 -0.052

SGBMH Servomotor

Encoder Plug

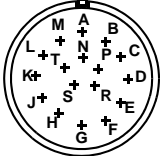

Connector Wiring on the Encoders			
A	—	K	—
B	—	L	—
C	Data +	M	—
D	Data -	N	—
E	—	P	—
F	—	R	—
G	0V	S	Battery - (Note*)
H	+5V _{dc}	T	Battery + (Note*)
J	FG (Frame Ground)		

*Note: Used with an absolute encoder only.
Non-Environmental Mating Connector:
MS3108B20-29S (L Type)
MS3106B20-29S (Straight Type)
Cable Clamp: MS3057-12A

Fan Connector

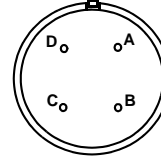

Fan Connector	
A	U Phase
B	V Phase
C	W Phase
D	—

Receptacle: CE05-2A18-10PD-B
Non-environmental mating connector:
MS3108B18-10S (L-Type)
CableClamp: MS3057-10A

Power Wiring Terminal Box		
Terminal	Connection	Screw Size
U, V, W	Motor	M10
⊕	Ground	

Selecting Your SGMBH Sigma Servo System

First, select the Sigma servomotor suited for your application using SigmaSize: the Yaskawa servomotor sizing software, available at no charge. (Request SigmaSize software via e-mail, at: literature@yaskawa.com).

Use the diagram below to locate and identify the components of your system. Each item is letter-coded and cross-referenced in the option tables on the following pages.

System Configuration

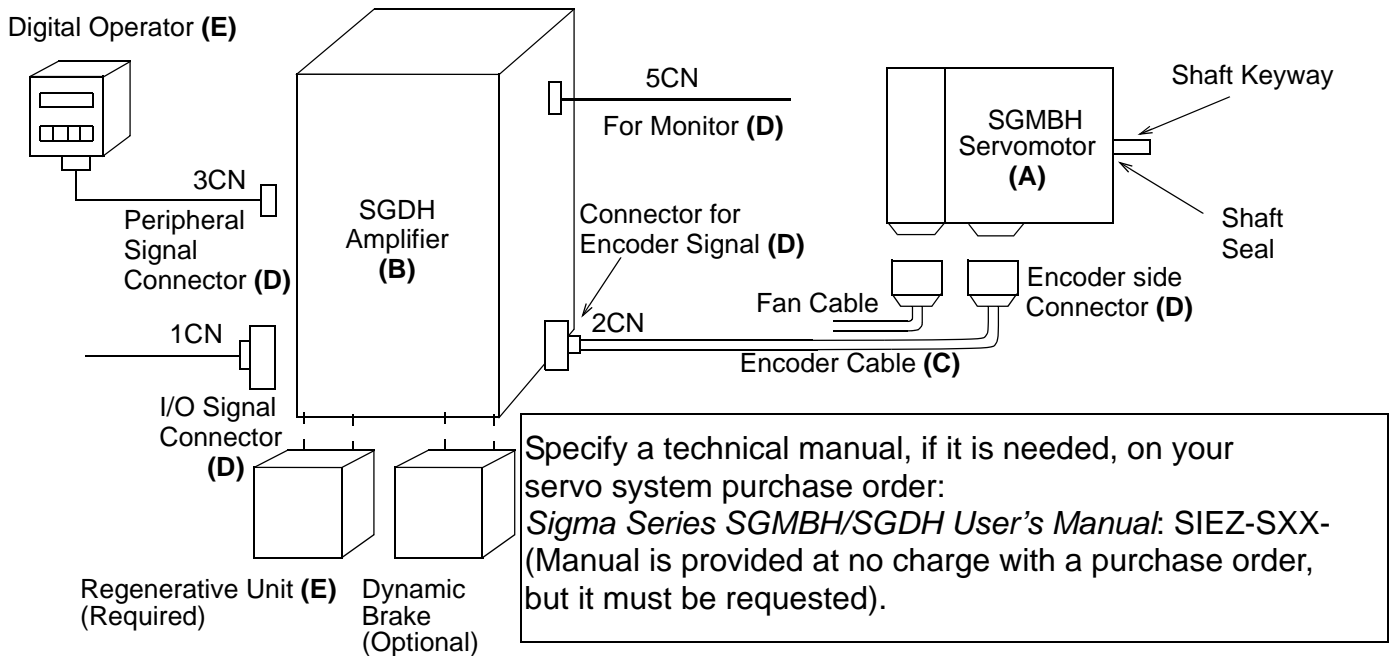

Model Number Designation

SGMBH - 2B D C A 6 1

<p>Sigma Servomotor Type SGMBH</p> <p>Rated Output</p> <p>2B: 22.0kW (30hp) 3Z: 30.0kW (40hp) 3G: 37.0kW (50hp) 4E: 45.0kW (60hp) 5E: 55.0kW (74hp)</p> <p>Power Supply</p> <p>D: 400 VAC Series</p> <p>Encoder Specifications</p> <p>C: 17-Bit Incremental Encoder 2: 17-Bit Absolute Encoder</p>	<p>Accessories</p> <p>1: None C: 24V_{DC} Brake (22+30 Kw Only) S: Shaft Seal E: Brake and Shaft Seal</p> <p>Specifications</p> <p>6: Flange, straight shaft with key and tap (Up to 45kW) L: Foot mount, straight shaft with key and tap (55kW only)</p> <p>Design</p> <p>A: Standard (Revision)</p>
---	---

Servomotor & Amplifier Selection

Use the table below to select the appropriate SGMBH Sigma servomotor and amplifier
(Refer to the motor model # designation on the previous page specifying the available modification to motor construction/features.).

Description	Peak Torque (in·lb)	Rated Torque (in·lb)	Motor Inertia (in·lb·s ² x 10 ⁻³)	Motor MODEL # (A)	Amplifier MODEL # (B)* Analog/Digital Input SGDH-	Regenerative Unit	Motor and Amplifier Item Class
400V 3-Phase 17-Bit Incremental Encoder	2480	1240	525	SGMBH-2BDCA61	2BDE	JUSP-RA12	Non-Stock
				SGMBH-2BDCA6C			
Straight Shaft with Keyway 2000rpm maximum	3380	1690	685	SGMBH-3ZDCA61	3ZDE	JUSP-RA13	
				SGMBH-3ZDCA6C			
MS Connectors	4170	2090	1230	SGMBH-3GDCA61	3GDE	JUSP-RA14	
	5060	2530	1336	SGMBH-4EDCA61	4EDE	JUSP-RA15	
	6120	3100	1750	SGMBH-5EDCAL1	5EDE	JUSP-RA16	

Note: 24V_{DC} brakes for SGMBH Sigma servomotors are standard. Contact a local source for 24V_{DC} power supplies.

* External regenerative units are required. For detailed SGDH amplifier specifications and dimensions, refer to pages 165 -188. Consult factory for availability of 37KW, 45KW, and 55KW motors with holding brakes.

400V Large Capacity Sigma II Servo System

Pre-wired Cable Selection

Use the table below to select pre-wired cables for your SGMBH Sigma servomotor.

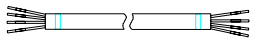
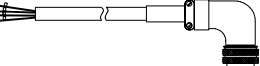
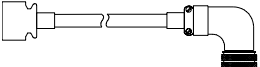
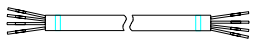
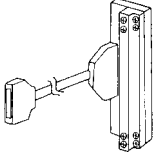
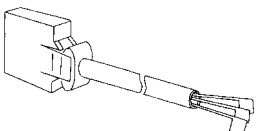
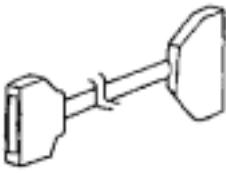
Cable Description (C)		Motor Size (kW)	Part Number		Comments	Item Class
			Without Brake	With Brake		
Recommended Power Cable ***		22	4×6AWG	4×6AWG 2×14AWG	Based on 30°C ambient temperature — —	Source Locally
		30	4×4AWG	4×4AWG 2×14AWG		
		37	4×2AWG	4×2AWG 2×14AWG		
		45, 55	4×1AWG	4×1AWG 2×12AWG		
SGMBH Fan Power Cable		All	B1E-□□(A)**		Use following key to specify cable length (last digit of part #): 03: 3m 05: 5m 10: 10m 15: 15m 20: 20m	Stock*
B1CE-□□(A)**						
Encoder Cable (incremental or absolute)			JZSP-CMP22-□□(A)**		Use following key to specify cable length (last digit of part #): 03: 3m 05: 5m 10: 10m (standard) 15: 15m 20: 20m	
Encoder Cable Only for solder connections (up to 50m)			JZSP-CMP29 - _ _		Use following key to specify cable length (last digit of part #): 20: 20m 50: 50m	
Input/Output 1CN Cable & Transition Terminal lock			JUSP-TA50P		35mm DIN rail mountable; the cable length is 0.5m.	
Input/Output 1CN Cable with Pigtail Leads			JZSP-CKI01-□(A)**		Use following key to specify cable length (last digit of part #): 1: 1m (standard) 2: 2m 3: 3m	
Input/Output 1CN Cable with Female D-Sub output Connector****			JZSP-CKI0D-□□		Use following key to specify cable length (last two digits of the part number): D50: 0.5m 01: 1m (standard) 02: 2m 03: 3m	

* Standard cable lengths are Stock items; non-standard cable lengths are Limited Stock items.





** This part of the cable number is the revision level. Cable revision can change and is independent of this catalog's reprinting.

*** Connectors for power cable should be ring terminals sourced locally by the customer, based on the motor power terminal block screw size given in the dimension pages.

**** 50 Pin Female D-Sub output connector mates to customer supplied third party terminal block. (e.g., Wago #289-449, Weidmuller #919658, Phoenix #2283647, Amphenol/Sine #20-51039, and many others).

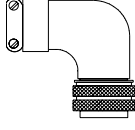
Connector Selection

Use the table below to select mating connectors for your SGMBH Sigma servomotor.

Connector Description (D)		Motor Size (kW)	Part Number	Comments	Item Class
MS Connector for Motor Fan*		All	MS3106B18-10S	Straight-type connector	Stock
			MS3108B18-10S	L-type connector	
			MS3057-10A	Cable clamp	
MS Connector for Encoder Cable (incremental or absolute encoder)			MS3106B20-29S	Straight-type connector	
			MS3108B20-29S	L-type connector	
			MS3057-12A	Cable clamp	
1CN Mating Connector			JZSP-CKI9	Can use 1CN for analog speed and torque monitor service checks.	
2CN Encoder Mating Connector			JZSP-CMP9-1	—	
3CN Peripheral Mating Connector	—		YSC-1	—	
5CN Connector and 1m Cable with Pigtails	—	DE9404559	—		

* Choose either a straight or L-type connector and the associated cable clamp for a complete assembly. For example, L-type connector MS3108B18-10S is compatible with cable clamp MS3057-10A. MS connectors listed in this table are non-environmental.

400V Large Capacity Sigma II Servo System

Peripheral Device Selection

Use the table below to select peripheral devices for your SGMBH Sigma servomotor.

Component (E)	Part Number	Description	Item Class
Hand-held Digital Operator Panel	JUSP-OP02A-1 and JUSP-CM500-1	Portable unit with 1m adapter cable for Sigma II.	Stock
SigmaWin+ Software	JZSP-WP0001	Minimum Recommended System Requirements Pentium 200 MHz, 64MB RAM, 200MB hard drive, CDROM Drive, RS-232 or RS-422 port, Screen resolution 800x600 w/ 256 colors, and Windows 95,98,NT4.0,2000,ME. (Windows XP planned)	
Absolute Encoder Battery	JZSP-BA01	3.6V, 1000mAh (Lithium Battery)	
Software Interface Cable	YS-12	Pre-wired 2.0m cable with 9-pin connector	
Optional Dynamic Brake Unit for 22kW and 30kW amplifiers	JUSP-DB03	—	Non-Stock
Optional Dynamic Brake Unit for 37kW amplifier	JUSP-DB04		
Optional Dynamic Brake Unit for 45kW amplifiers	JUSP-DB05		
Dynamic Brake Resistor Unit for 55kW amplifiers	JUSP-DB06		

SGDH Servo Amplifier- For Speed, Torque, & Position Control With Incremental or Absolute Encoder



400V

Three-phase

For Additional Information	Page(s)
SGDH Ratings & Specifications	167 - 168
SGDH Dimensions	169 - 188
SGDH Connections	189 - 197
Peripherals	198 - 200
SGMGH Sigma II Servo System	127 - 138
SGMSH/UH Sigma II Servo System	139 - 152
SGMBH sigma II Servo System	153 - 164

Design Features

1. Improved Performance

- Higher bandwidth response (up to 400Hz speed loop frequency response)
- Positioning settling time shortened to 1/2 to 1/3
- Smooth control at low rpm
made possible by Sigma II servomotors' high resolution feedback

2. Easy Operation

- All-in-one model (speed, torque, and position control)
- PC monitoring function available including graphical tuning and file storage
- Adaptive-tuning function
Online auto-tuning
- Multi-axis communication provided as standard
One PC can communicate with up to 14 SGDH units by parameter setting
- Built-in parameter setting device
- On-board storage of alarm history
- Automatic determination of motor settings at connection

3. Additional functionality with ready-to-install application modules

- Configurable single axis controls including serial communication capability
- Fieldbus connectivity (Devicenet™, Profibus™, etc.)
- Full closed loop (optional position feedback)
- Single axis motion controller

4. Certified International Standards

- UL, cUL listed (File #: E147823), CE compliance

Model Number Designation

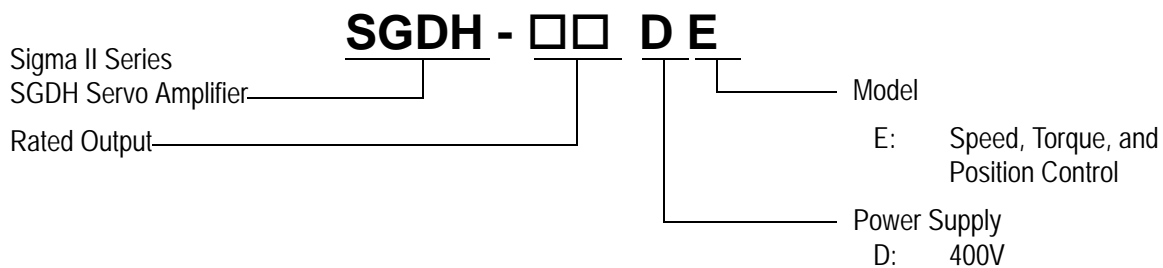

Amplifier Model	Capacity kW (HP)	AC Supply Phases
05	0.5 (.67)	3
10	1.0 (1.3)	
15	1.5 (2.0)	
20	2.0 (2.7)	
30	3.0 (4.0)	
50	5.0 (6.7)	
60	6.0 (8.0)	
75	7.5 (10)	
1A	11 (15)	
1E	15 (20)	
2B	22 (30)	
3Z	30 (40)	
3G	37 (50)	
4E	45 (60)	
5E	55 (74)	

SGDH Amplifier Ratings and Specifications

Basic Specifications	Input Power Supply	Main Circuit	Three-phase 380 to 480V _{ac} +10% to -15%, 50/60 Hz.		
		Control Circuit	1. 24V _{DC} ±10% to ±15%, 1A (maximum) 2. 24V _{DC} ±10%, 40W for 22 to 55kW units Note: For 22 to 55kW units only, the power supply for the optional dynamic brake (DB) contactor is made from the control circuit power supply. If DB operation is necessary when the power interruption occurs, maintain the DC24V while the DB operates. If 5 times inertia is attached and a standard DB resistor is used, DB operation time is approximately 2 to 5 seconds.		
	Control Mode		Three-phase, full-wave rectification IGBT PWM (sinusoidal commutation)		
	Feedback		Serial incremental encoder, absolute encoder		
	Location	Ambient/Storage Temperature *		0 to 55°C / -20 to 85°C	
		Ambient/Storage Humidity		90% or less (no-condensing)	
		Vibration/Shock Resistance		1. 4.9m/s ² / 19.6m/s ² for 500W to 15kW units 2. 9.8m/s ² (1G) / 49m/s ² (5G) for 22 to 55kW units Cyclic shock resistance is 29m/s ² (3G)	
	Structure		Base mounted (duct ventilation available as option) and flat mount type		
	Speed/Torque Control Mode	Performance	Speed Control Range		1 : 5000 (The lowest speed of the speed control range is the speed at which the servomotor will not stop with a rated torque load.)
			Speed Regulation **	Load Regulation	0% to 100%: 0.01% max. (at rated speed)
Voltage Regulation				Rated voltage ±10% : 0% (at rated speed)	
Temperature Regulation				25 ± 25°C : 0.1% maximum (at rated speed)	
Frequency Characteristics			400Hz (at J _L = J _M) Note: 100 Hz (J _L = J _M) for 22 to 55kW systems		
Accel/Decel Time Setting		0 to 10s (Can be set individually for acceleration and deceleration).			
Input Signal		Speed Reference	Reference Voltage ***	±6V _{DC} (variable setting range: ±2 to ±10V _{DC}) at rated speed (forward rotation with positive reference); input voltage: ±12V (maximum)	
			Input Impedance	Approximately 14kΩ	
			Circuit Time Constant	—	
		Torque Reference	Reference Voltage ***	±3V _{DC} (Variable setting range: ±1 to ±10V) at rated torque (forward rotation with positive reference), input voltage: ±12V _{DC} (maximum)	
	Input Impedance		Approximately 14kΩ		
	Circuit Time Constant		Approximately 47μs		
	Contact Speed Reference	Rotation Direction Selection	Uses P control signal		
Speed Selection		Forward/reverse rotation current limit signals are used (first to third speed selection). When both signals are OFF, the motor stops or enters another control mode.			

Notes: * Use the servo amplifier within the ambient temperature range. When enclosed, the temperatures inside the cabinet must not exceed the specified range.

** Speed regulation is defined as follows:

$$\text{Speed regulation} = \frac{(\text{no-load motor speed} - \text{full-load motor speed})}{\text{rated motor speed}} \times 100\%$$

*** Forward is clockwise viewed from the non-load side of the servomotor, (counterclockwise viewed from the load and shaft end).

Ratings and Specifications (cont'd)

Positioning Control Mode	Performance	Bias Setting		0 to 450rpm (setting resolution: 1rpm)	
		Feed-forward Compensation		0 to 100% (setting resolution: 1%)	
		Position Complete Width Setting		0 to 250 reference units (setting resolution: 1 reference unit)	
	Input Signal	Reference Signal	Type	Sign + pulse train, 90° phase difference 2-phase pulse (phase A + phase B), or CCW + CW pulse train	
			Pulse Buffer	Line driver (+5V level), open collector (+5V or +12V level)	
			Pulse Frequency	Maximum 500/200kpps (line driver/open collector)	
Control Signal		CLEAR (input pulse form identical to reference pulse)			
Built-in Open Collector Power Supply *		+12V (With built-in 1kW resistor)			
I/O Signals	Position Output	Output Form		Phases A, B and C: Line driver output Phase S: Line driver output (Only when absolute encoder is used)	
		Frequency Dividing Ratio		Any	
	Sequence Input		Servo ON, P control (or forward/reverse rotation in contact input speed control mode), forward rotation prohibited (P-OT), reverse rotation prohibited (N-OT), alarm reset, forward rotation current limit, and reverse rotation current limit (or contact input speed control)		
	Sequence Output	—		Servo alarm, 3-bit alarm codes	
		Configurable: (Any 3 of these signals)		Positioning complete (speed coincidence), servomotor rotating, servo ready, current limit, brake release, warning, and near position signals	
Built-in Functions	Dynamic Brake (DB)		Activated at main power OFF, servo alarm, servo OFF or overtravel		
	Regenerative Processing		Incorporated. For 6 to 55 kW units, external regenerative resistor must be mounted.		
	Overtravel (OT) Prevention		Motor decelerates or coasts to a stop, or is stopped by a dynamic brake. This requires optional dynamic brakes for 22 to 55kW units.		
	Protection		Overcurrent, overload, regenerative error, main circuit voltage error, heat sink overheat, power open phase, overflow, overspeed, encoder error, encoder disconnected, overrun, CPU error, parameter error.		
	LED Display		POWER, CHARGE, five 7-segment LEDs (built-in digital operator functions)		
	Analog Monitor (5CN)		Built-in analog monitor connector to observe speed, torque, and other reference signals Speed: 1V/1000rpm Torque 1V/rated torque Pulses remaining: 0.05V/reference units or 0.05V/100 reference units		
	Communication	Interface		Digital operator (mount type or hand-held) RS422A port such as person computer (RS-232C port can be used if some conditions are met).	
		1 : N Communication		N can be up to 14 when RS-422A port is used.	
		Axis Address Setting		Set via user parameters	
	Functions		Status display, user constant setting, monitor display, alarm traceback display, jogging, autotuning, speed/torque reference signals, other graphing functions, etc.		
Others		Reverse rotation connection, home position search, automatic servomotor ID, DC reactor connection terminal for high power supply frequency control.			

Note: * The built-in open collector power supply is not electrically isolated from the control circuit in the servo amplifier.

Dimensions in inches (mm)

SGDH Servo Amplifier

- SGDH-05DE, -10DE, -15DE (400V Three-phase, 0.5kW to 1.5kW)

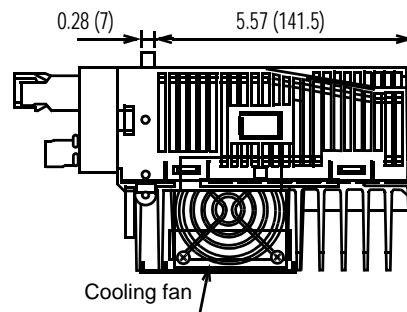
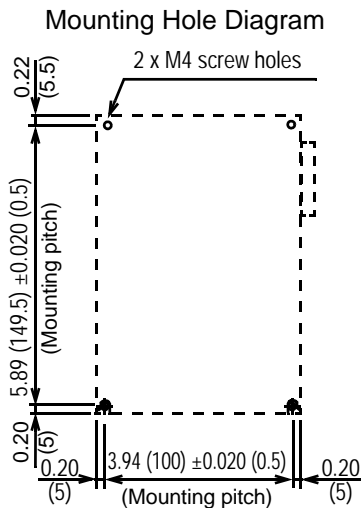
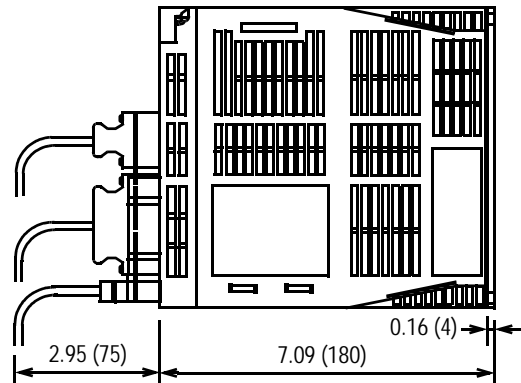
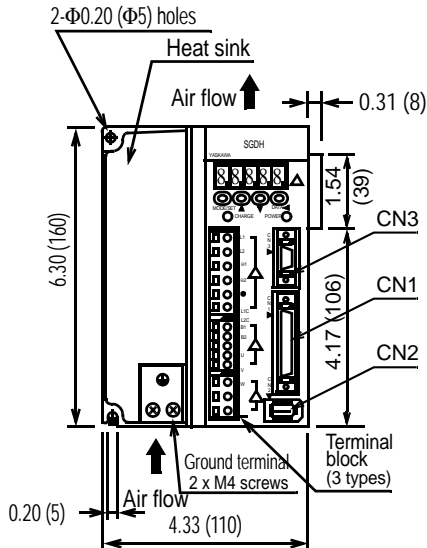

Approximate mass: 6.17lb (2.8kg)

Connectors on the amplifier (supplied):

Connector Symbol	Servo Amplifier Receptacle	Manufacturer
CN1	10250-52A2JL	3M Company
CN2	53460-0611	Molex Co.
CN3	10214-52A2JL	3M Company

User needs to obtain the following:

Connector Symbol	Mating Connector	Manufacturer
1CN	10150-3000VE connector 10350-52A0-008 case	3M Company
2CN	55100-0600	Molex Co.
3CN	JEZ-9S connector J-C9-2C case	JST Company

400V Sigma II Servo Systems

- SGDH-20DE, 30DE (400V Three-phase, 2.0kW, 3.0kW)

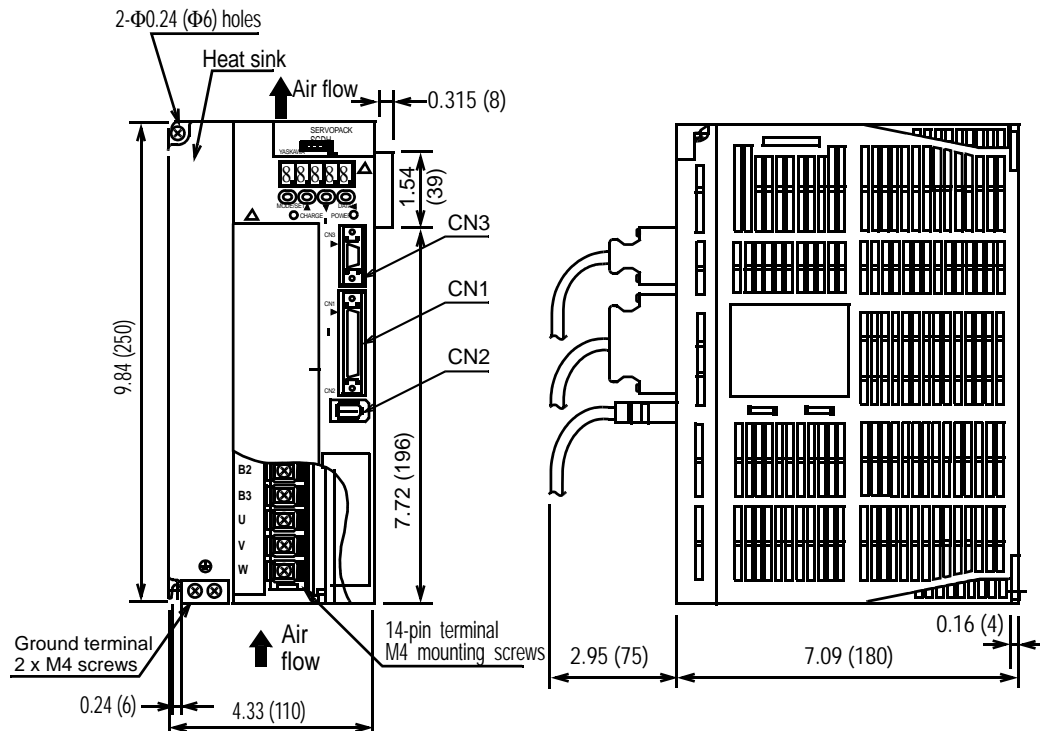

Mounting Hole Diagram

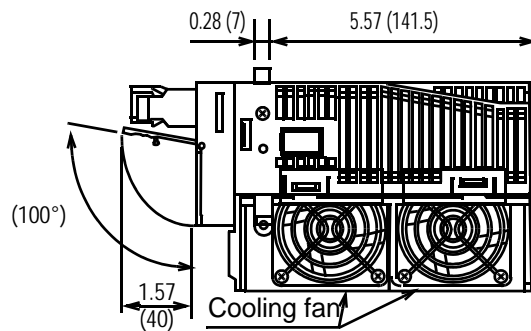
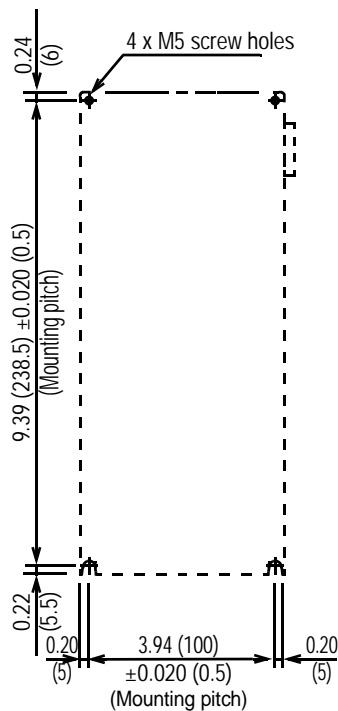

Approximate mass: 8.38lb (3.8kg)

Mating connectors: [See page 167](#)

- **SGDH-50DE (400V Three-phase, 5.0kW)**

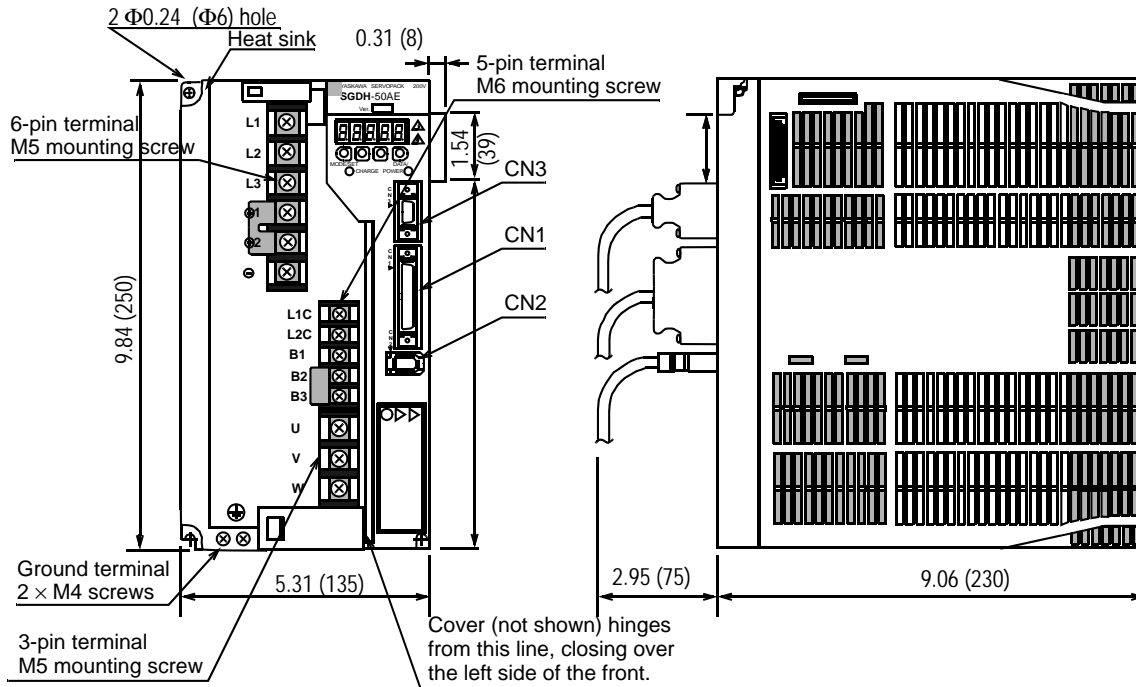

Mounting Hole Diagram

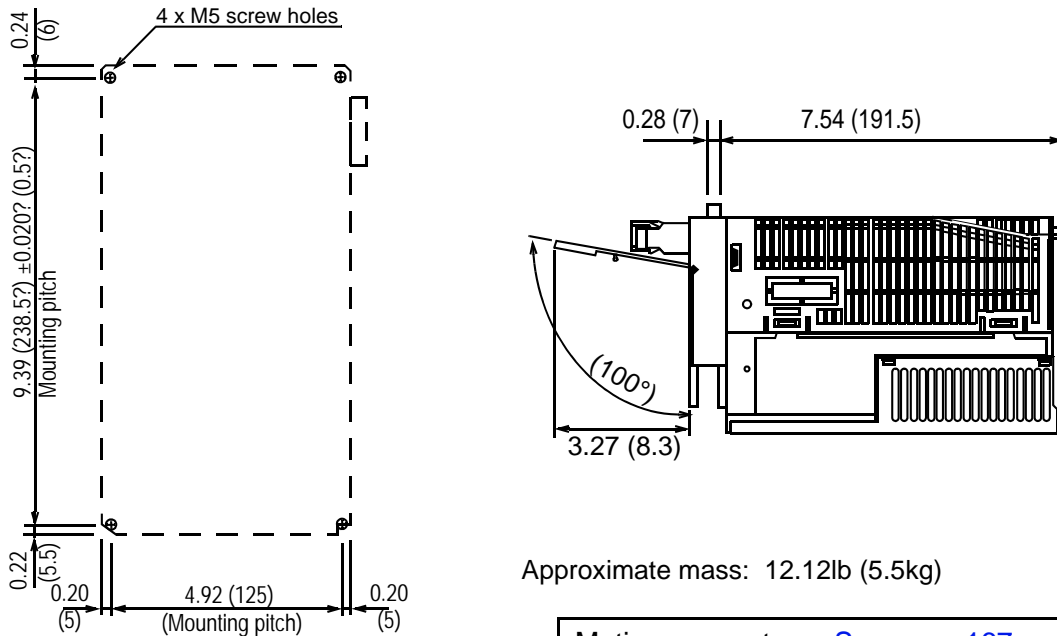

Approximate mass: 12.12lb (5.5kg)

Mating connectors: [See page 167](#)

400V Sigma II Servo Systems

- SGDH-60DE, SGDH-75DE (400V Three-phase, 6.0kW, 7.5kW)

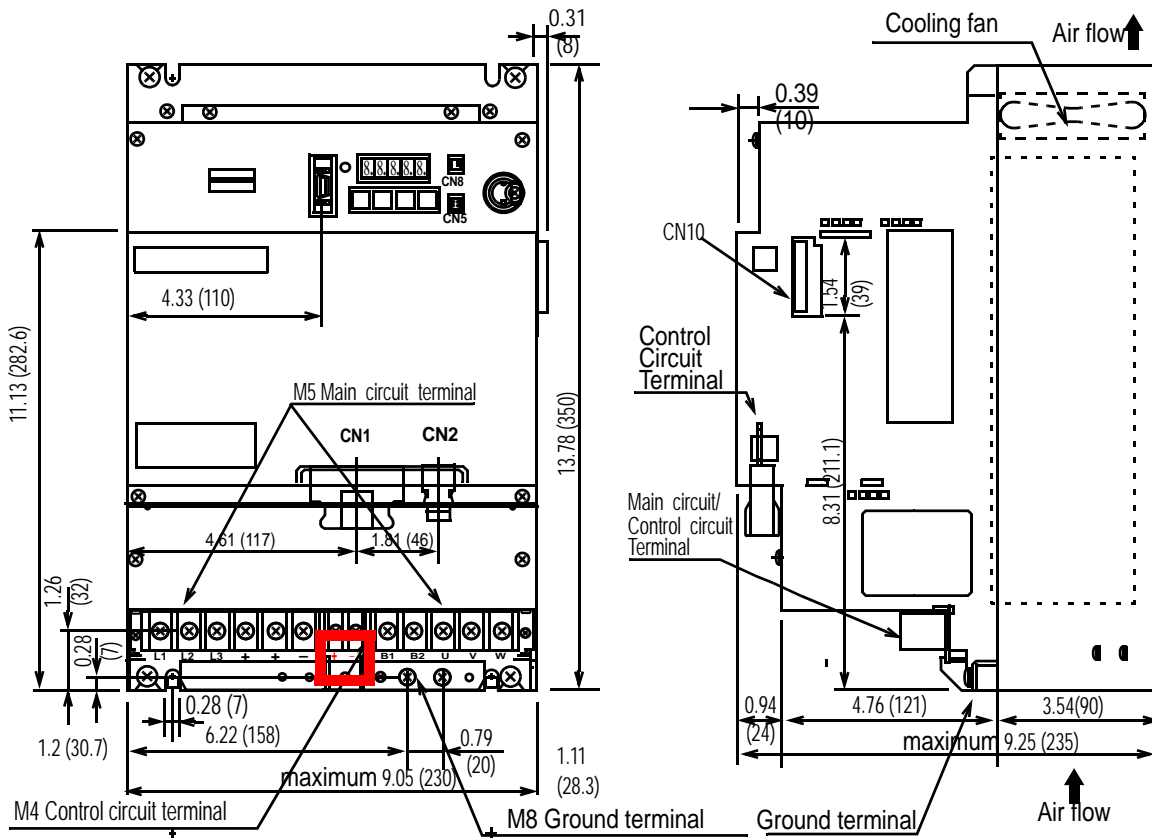

Mounting Hole Diagram::

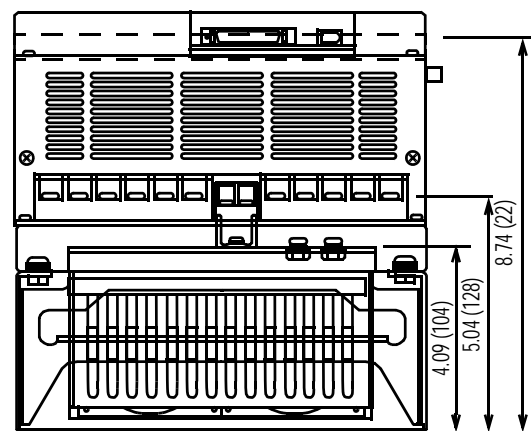
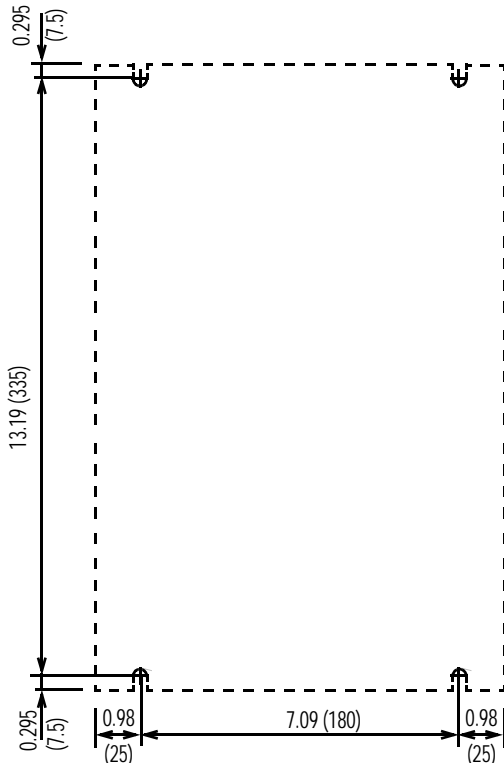

Approximate mass: 29.8lb (13.5kg)

Mating connectors: [See page 167](#)

- **SGDH-1ADE, SGDH-1EDE (400V Three-phase, 11.0kW, 15.0kW)**

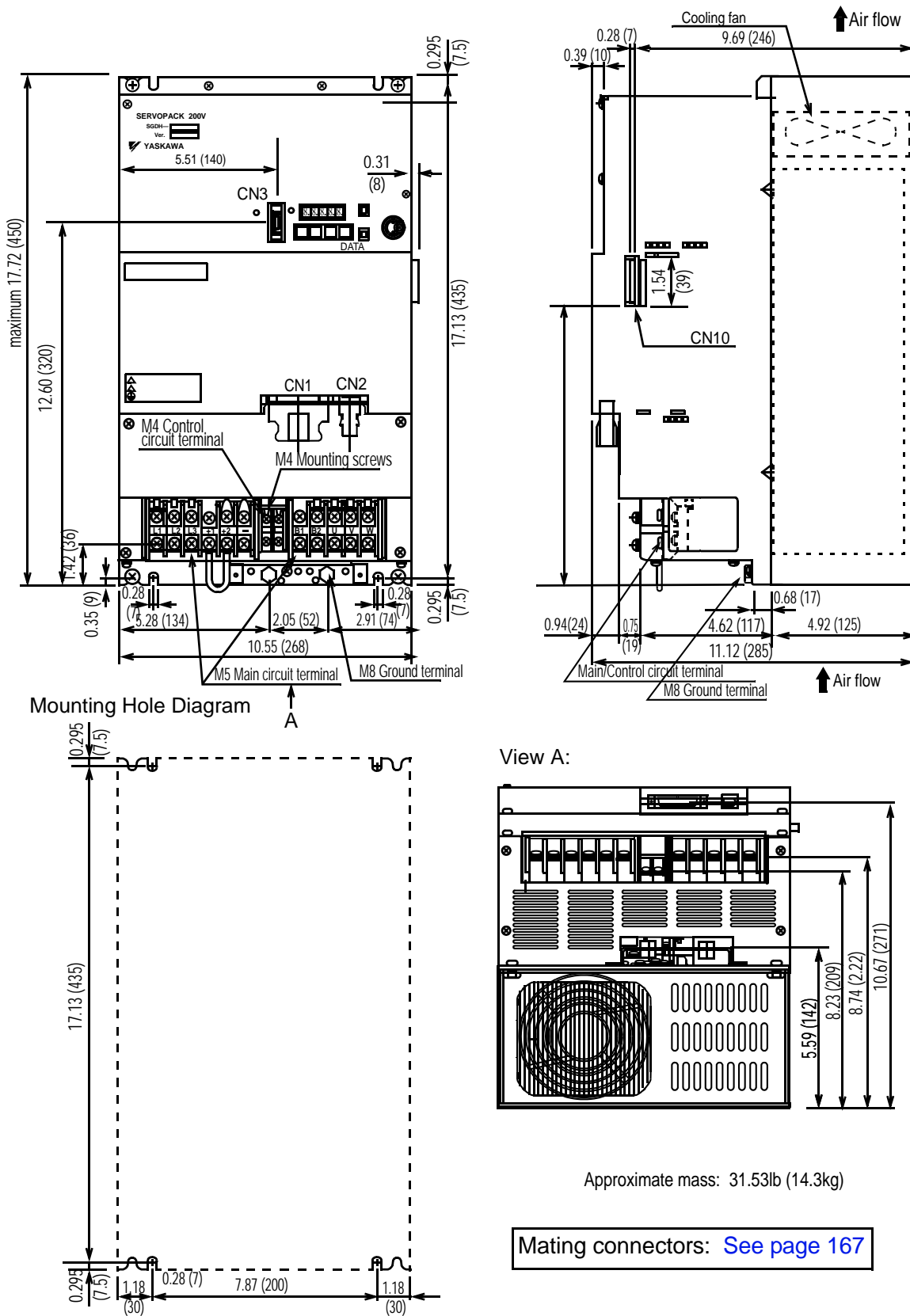

Approximate mass: 31.53lb (14.3kg)

Mating connectors: [See page 167](#)

400V Sigma II Servo Systems

- **SGDH-2BDE (400V Three-phase, 22kW)**

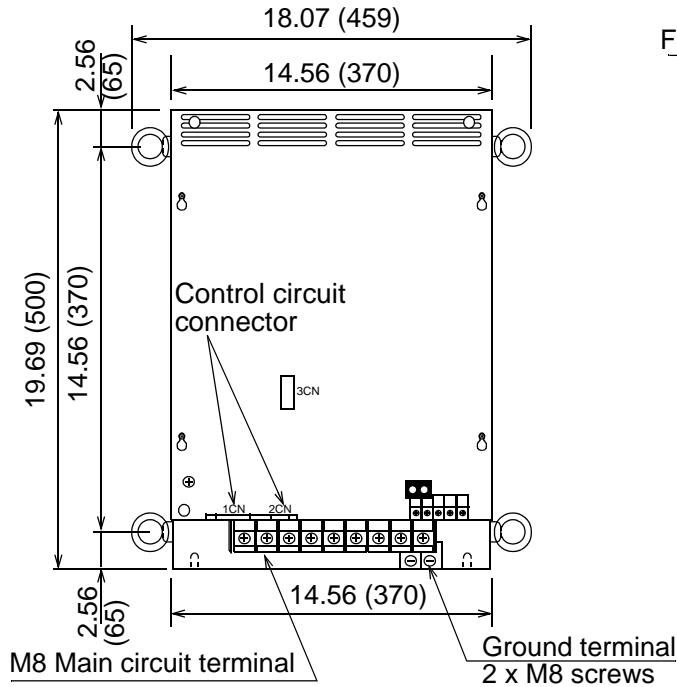

Mounting Hole Diagram

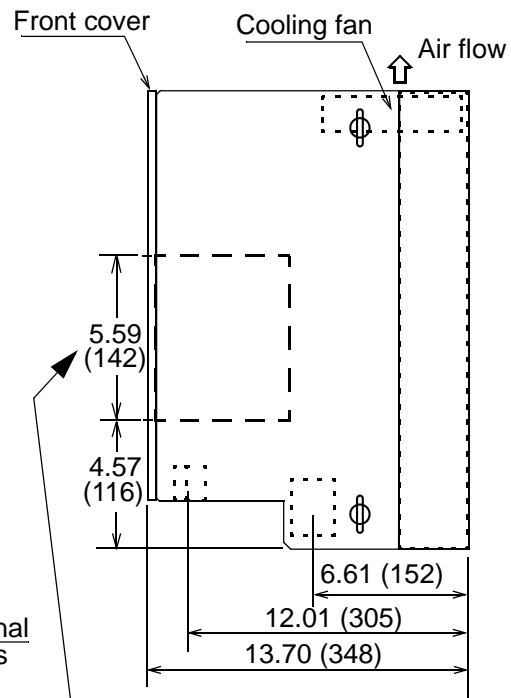
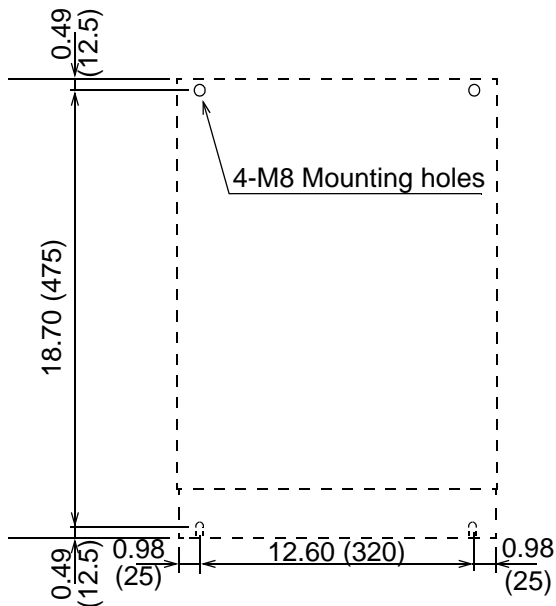

Note: Dimensions are for positioning of application module. Unlike other Sigma II amplifiers, the male connector is inset into the amplifier so that it does not protrude past the outside edge.

Approximate Mass: 88.2lb (40kg)

Mating connectors: [See page 167](#)

- **SGDH-3ZDE(400V Three-phase, 30kW)**

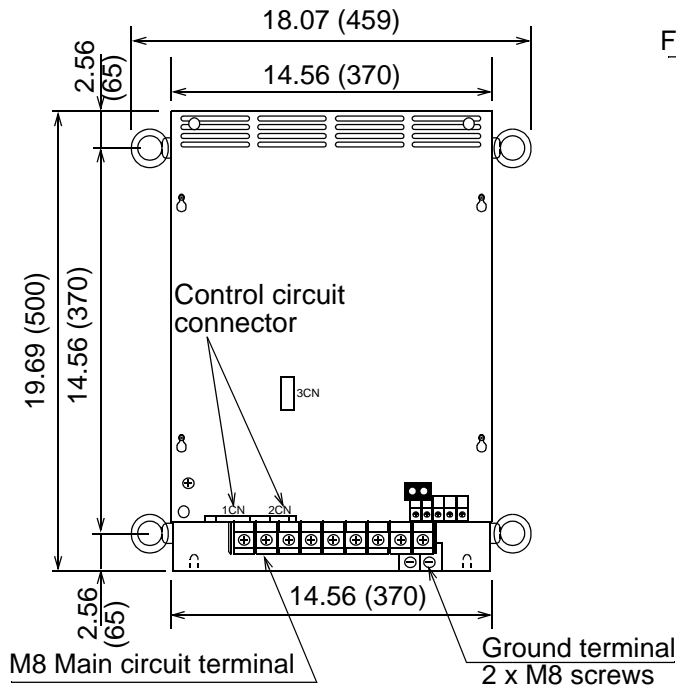

Mounting Hole Diagram

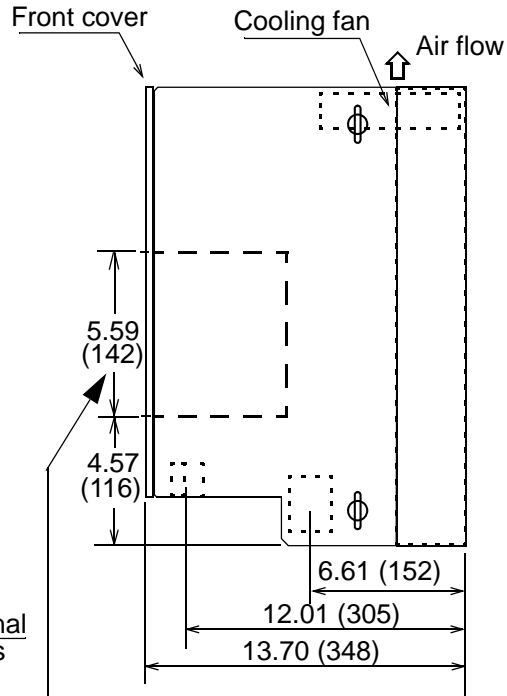
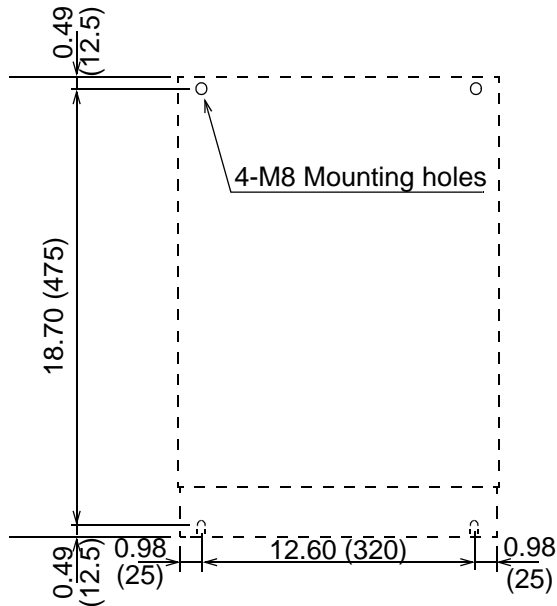

Note: Dimensions are for positioning of application module. Unlike other Sigma II amplifiers, the male connector is inset into the amplifier so that it does not protrude past the outside edge.

Approximate Mass: 82.2lb (40kg)

Mating connectors: [See page 167](#)

400V Sigma II Servo Systems

- **SGDH-3GDE (400V Three-phase, 37kW)**

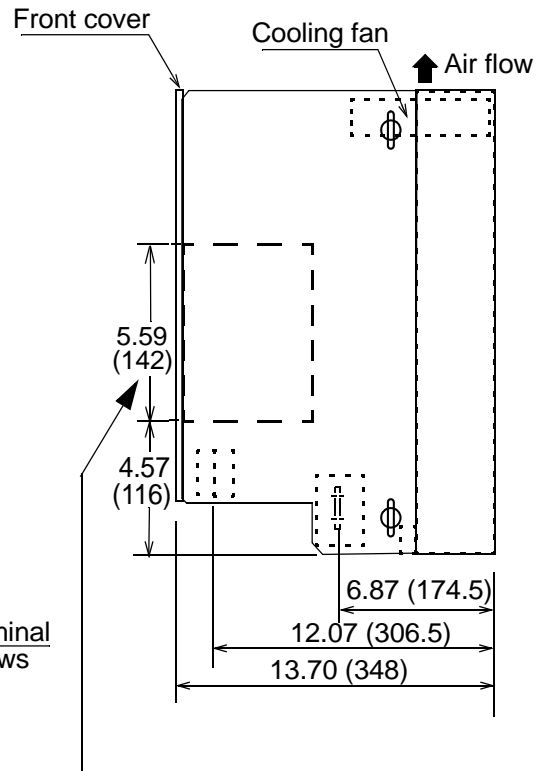
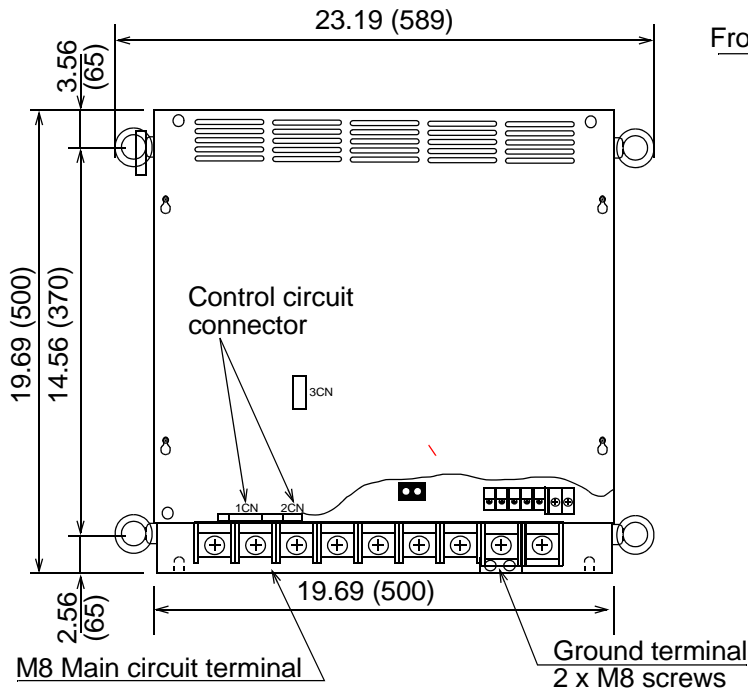

Mounting Hole Diagram

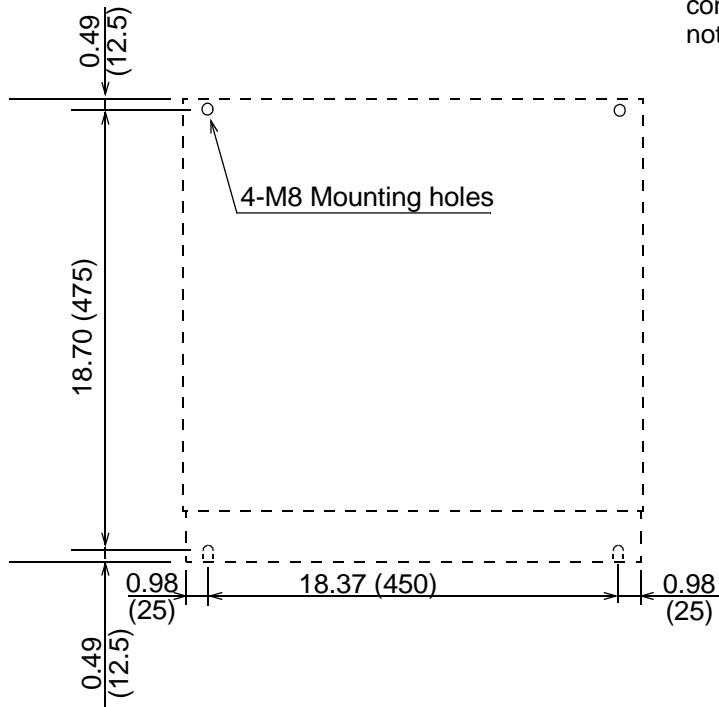

Note: Dimensions are for positioning of application module. Unlike other Sigma II amplifiers, the male connector is inset into the amplifier so that it does not protrude past the outside edge.

Approximate Mass: 132.3lb (60kg)

Mating connectors: [See page 167](#)

- **SGDH-4EDE (400V Three-phase, 45kW)**
- **SGDH-5EDE (400V Three-phase, 55kW)**

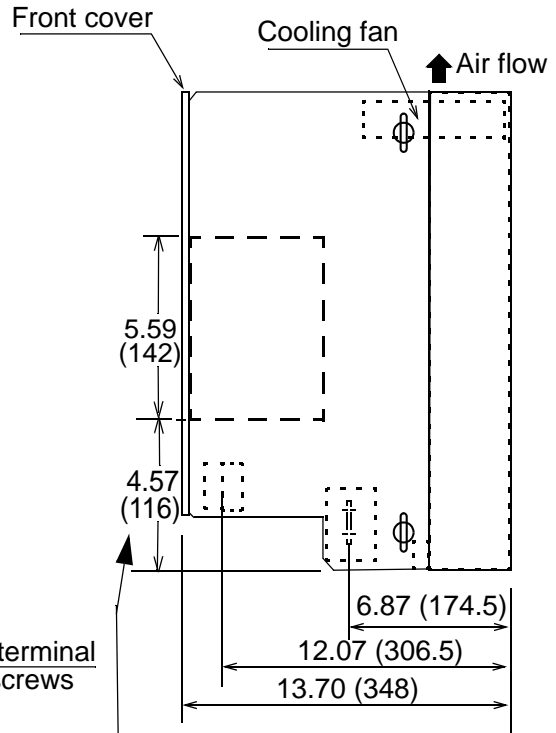
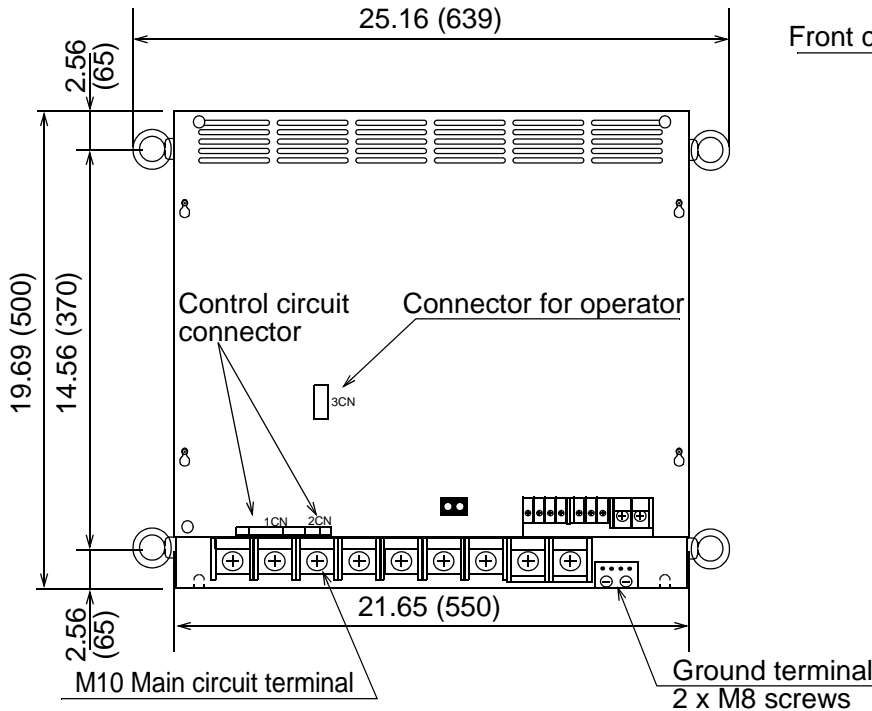

Mounting Hole Diagram

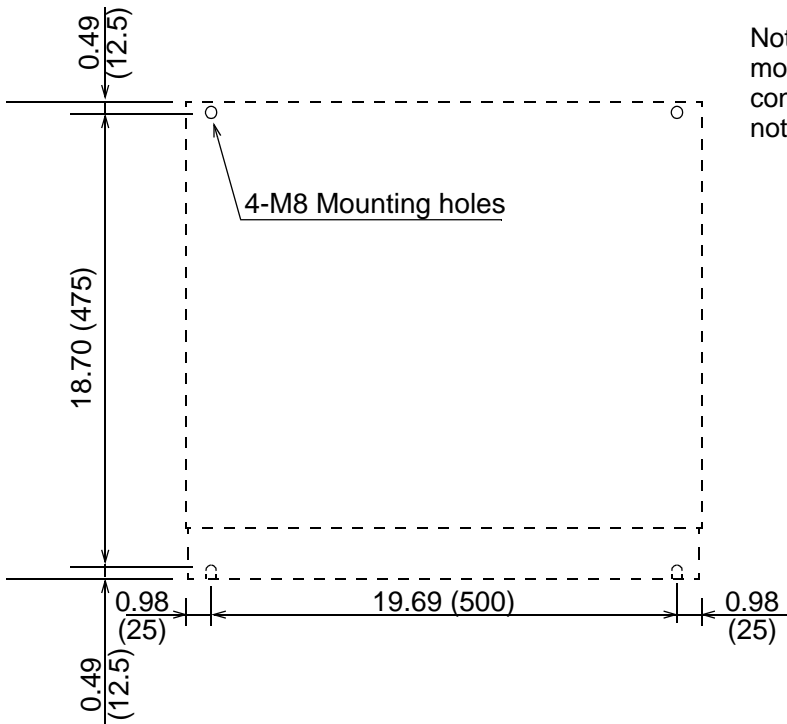

Note: Dimensions are for positioning of application module. Unlike other Sigma II amplifiers, the male connector is inset into the amplifier so that it does not protrude past the outside edge.

Approximate Mass: 143.3lb (65kg)

Mating connectors: [See page 167](#)

Regenerative Resistor Units (JUSP-RA□□)

Externally attach a regenerative resistor to the servopack. This resistor is used for dissipating regenerative energy.

Use one of the following regenerative resistor units according to the servopack model.

Servopack Model SDGH-	2BDE	3ZDE	3GDE	4EDE	5EDE
Regenerative Resistor Unit JUSP-	RA12	RA13	RA14	RA15	RA16
Resistance	9Ω	6.7Ω	5Ω	4Ω	3.8Ω
Resistance Capacity	3600W	3600W	4800W	6000W	7200W
Allowable Load Moment of Inertia	5 times the load moment of inertia at motor shaft.				
Allowable Duty	2% ED at maximum speed and torque deceleration.				

• JUSP-RA12

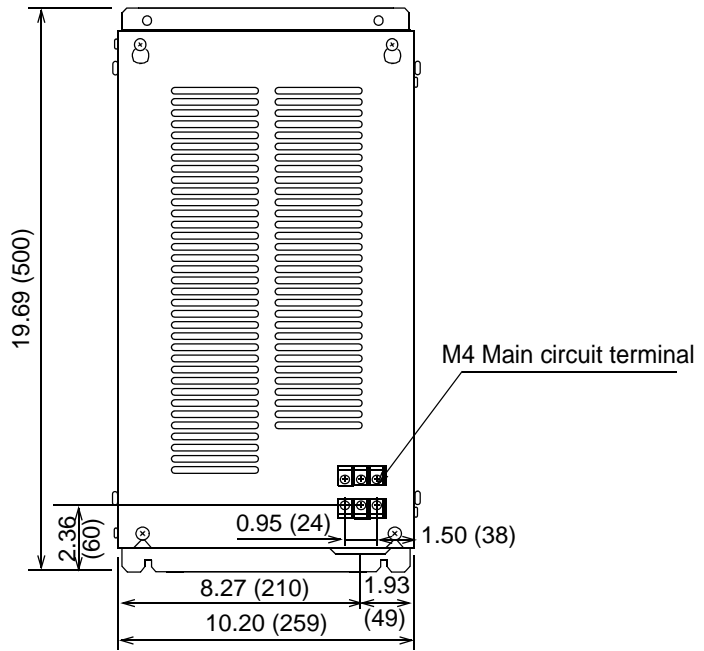
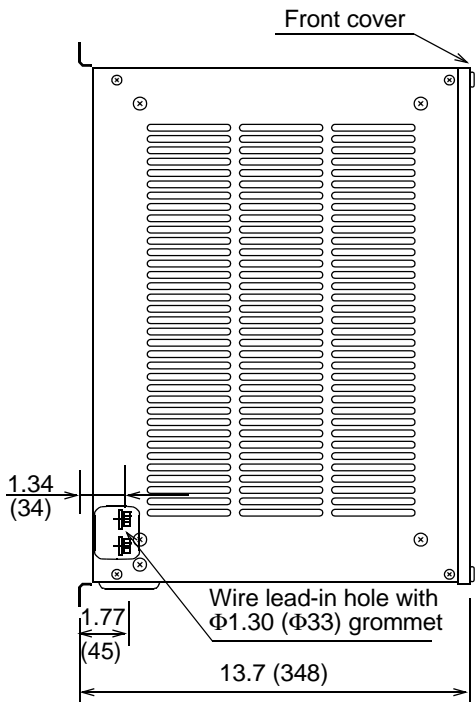

Mounting Hole Diagram

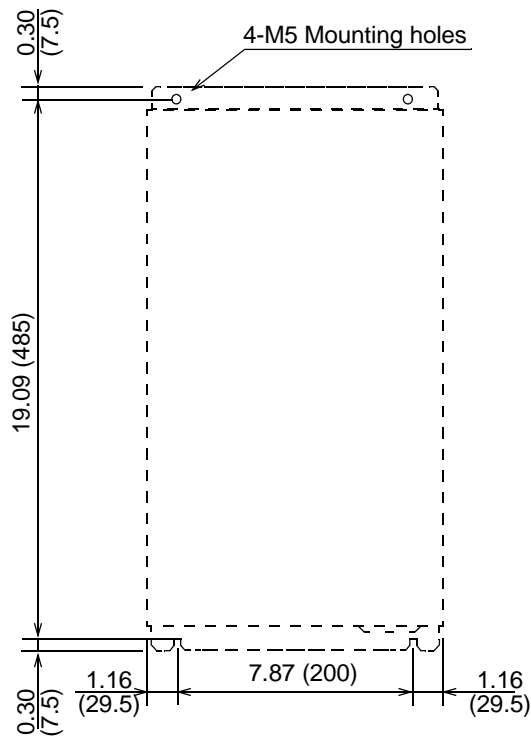

Approximate Mass: 30.9lb (14kg)

400V Sigma II Servo Systems

- JUSP-RA13

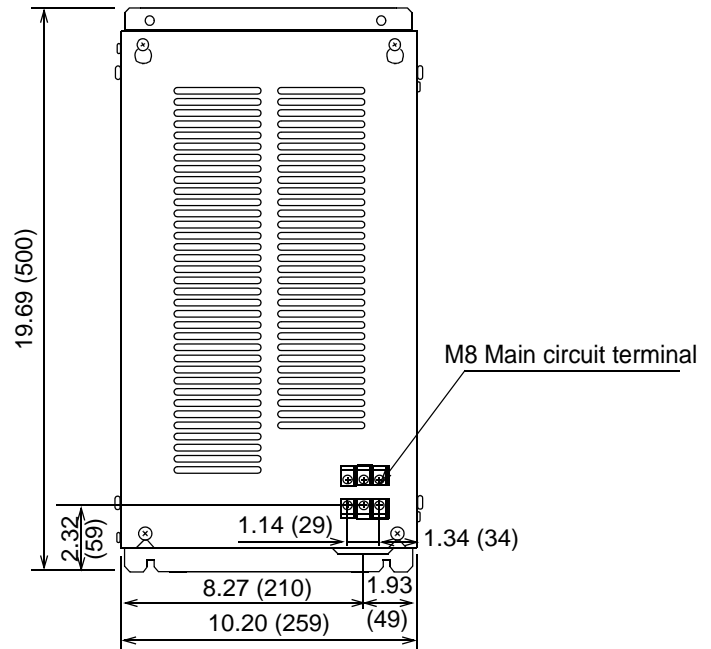
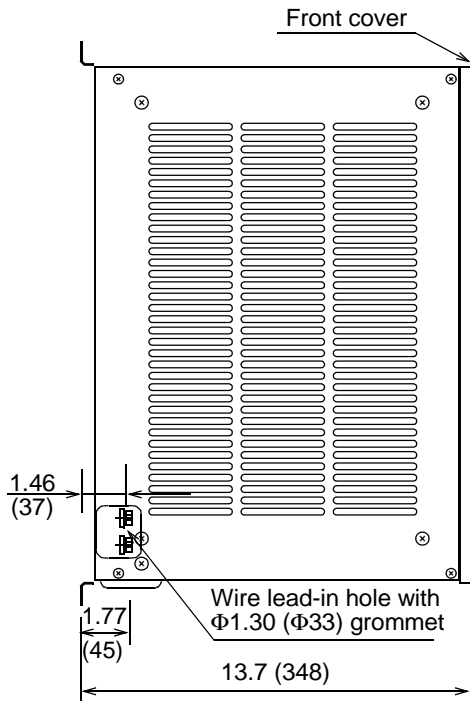

Mounting Hole Diagram

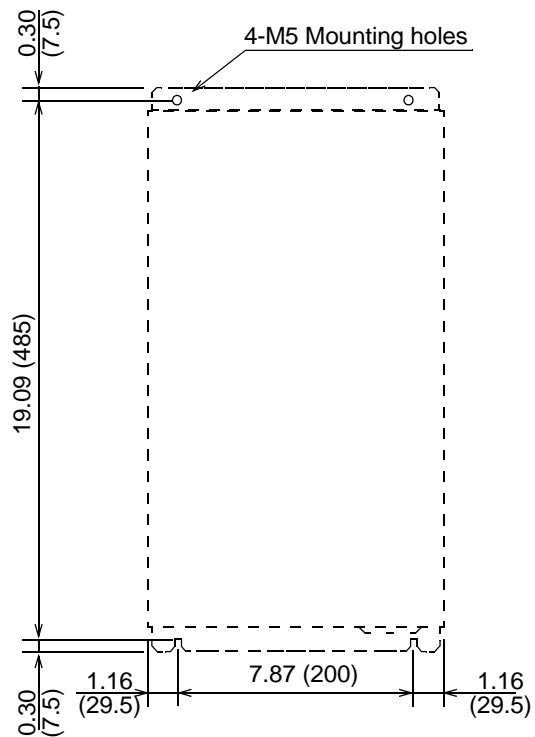

Approximate Mass: 30.9lb (14kg)

- JUSP-RA14

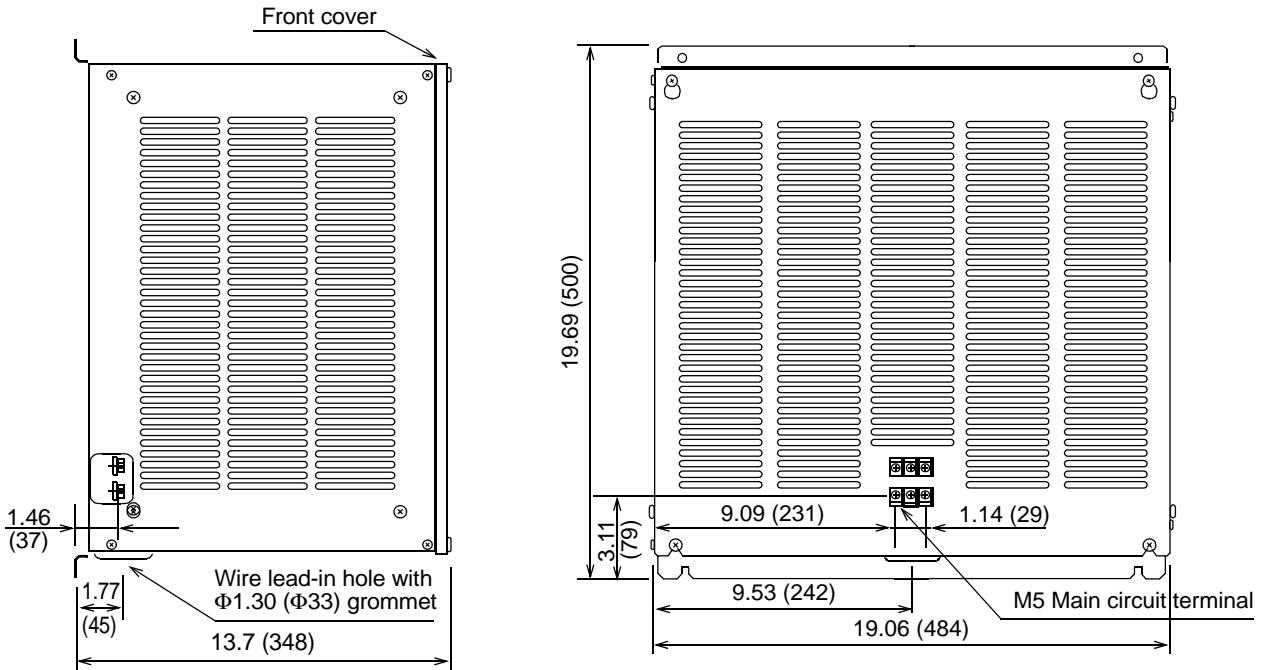

Mounting Hole Diagram

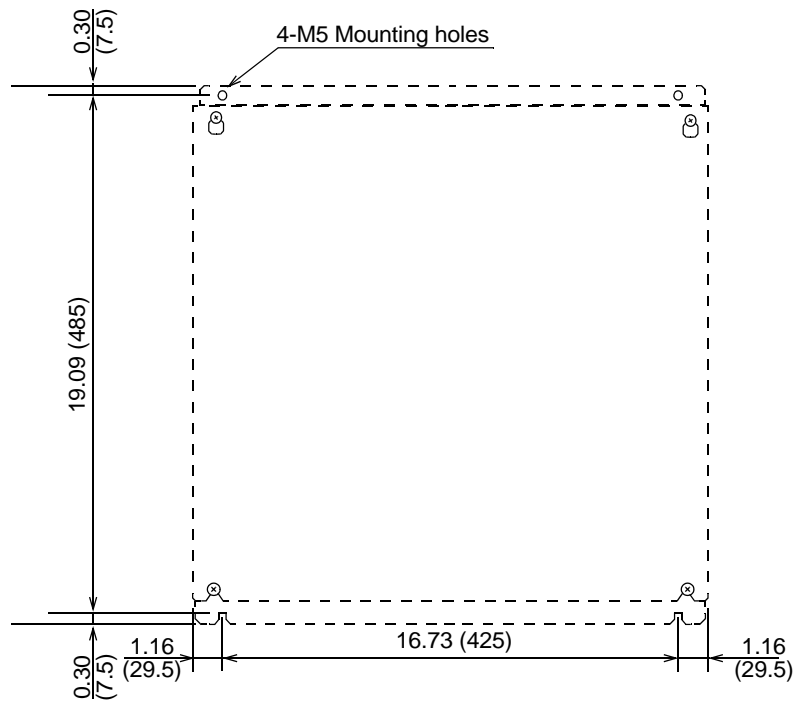

Approximate Mass: 44.1lb (20kg)

400V Sigma II Servo Systems

- JUSP-RA15

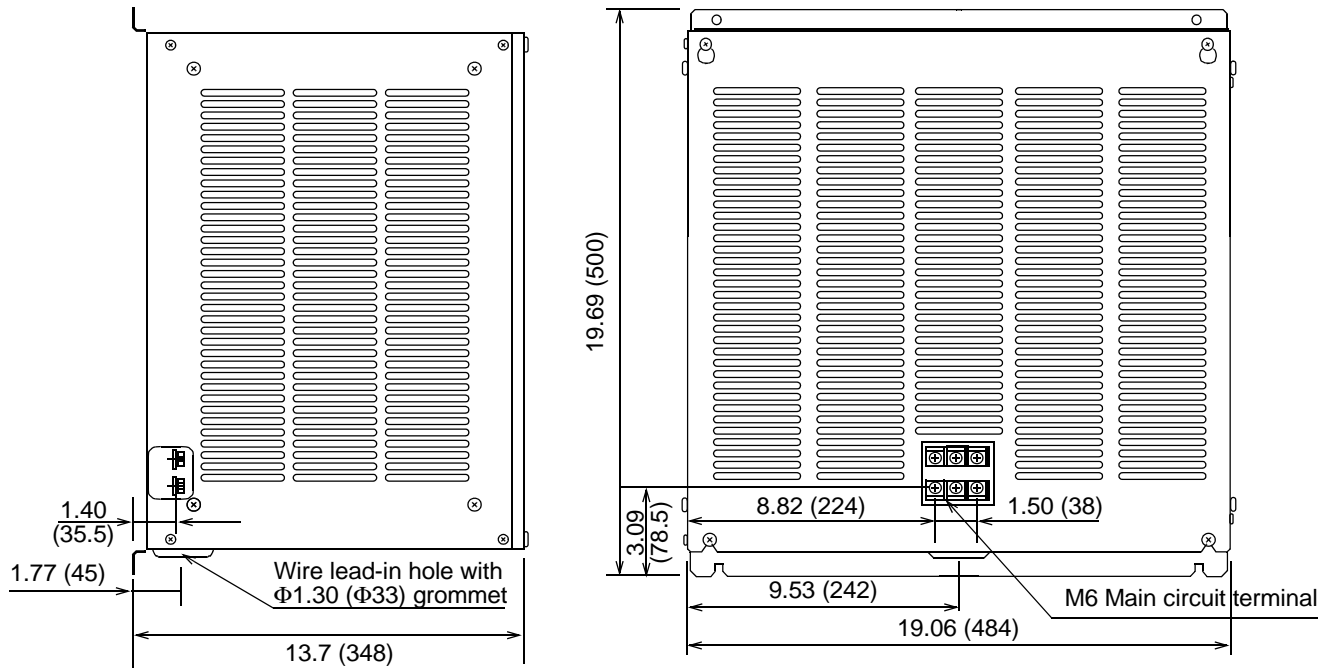

Mounting Hole Diagram

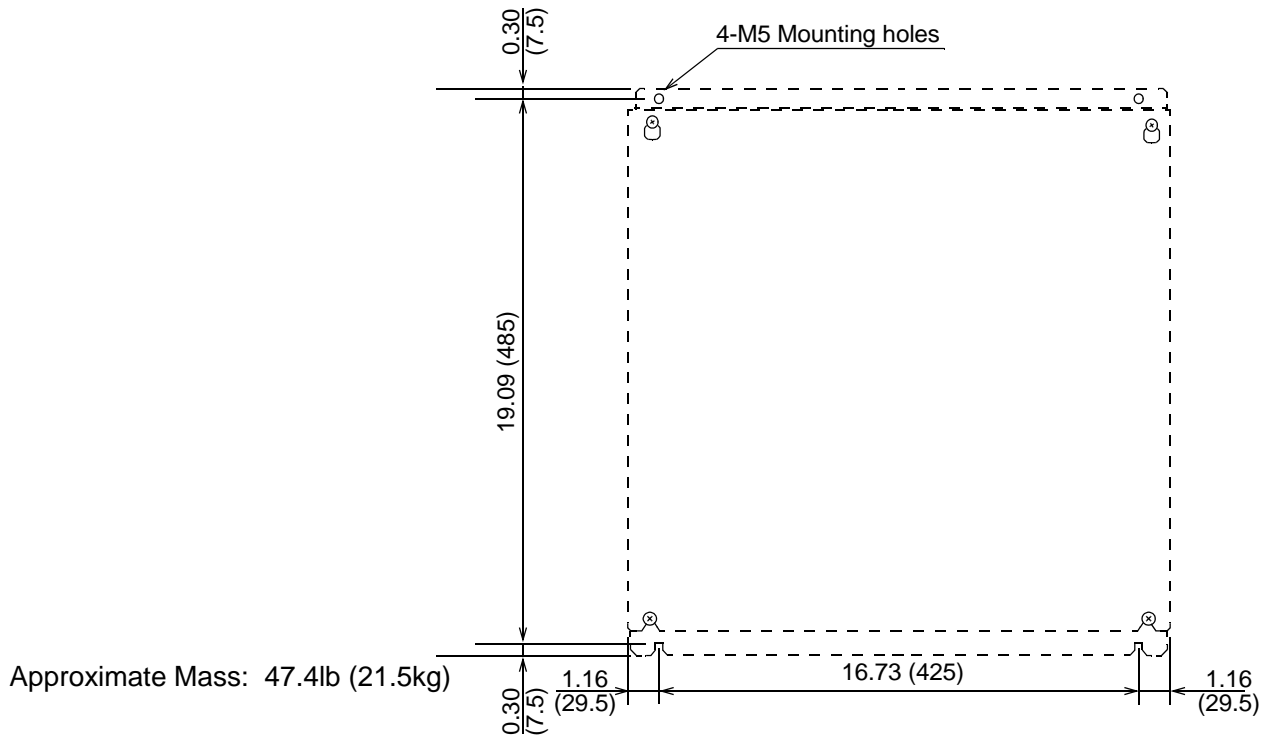

- JUSP-RA16

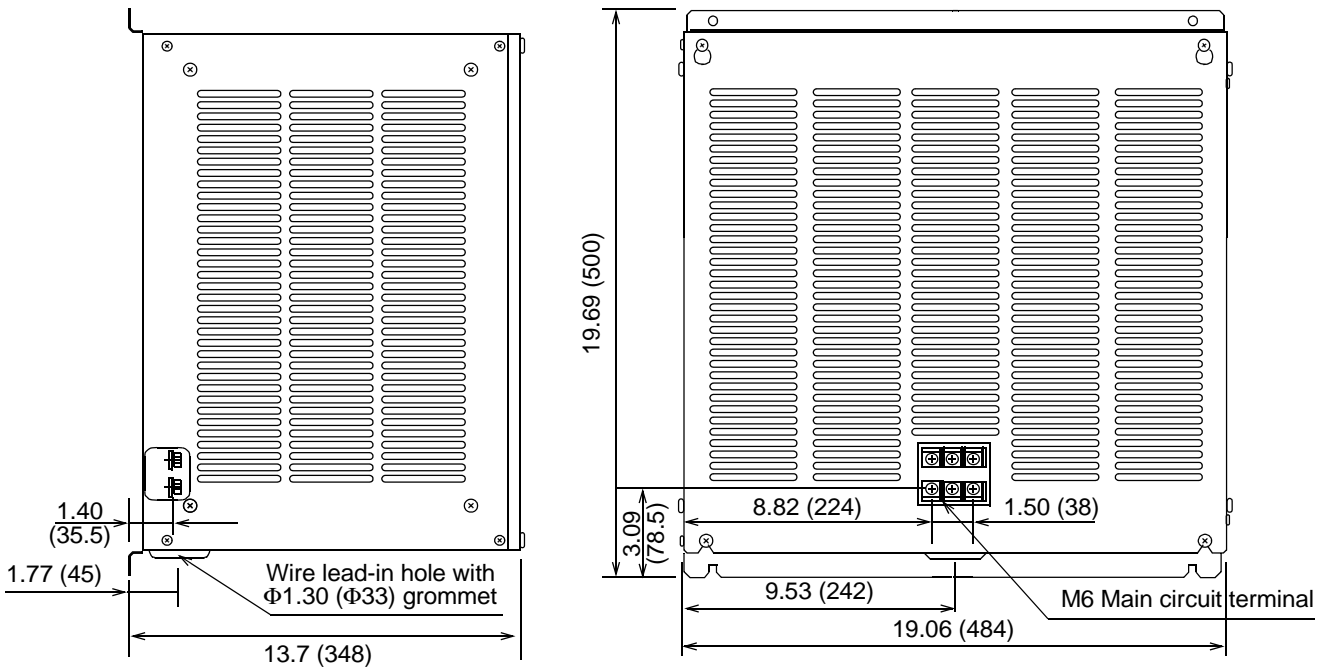

Mounting Hole Diagram

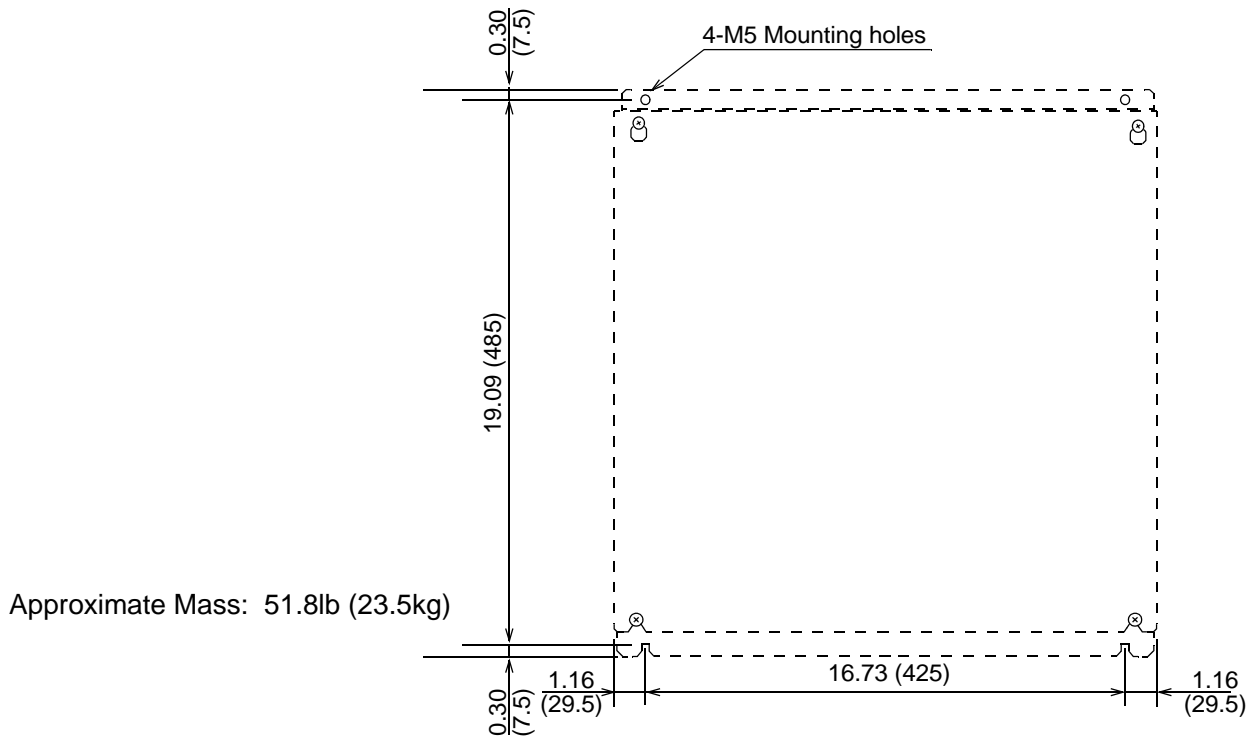

400V Sigma II Servo Systems

• Type JUSP-RA18

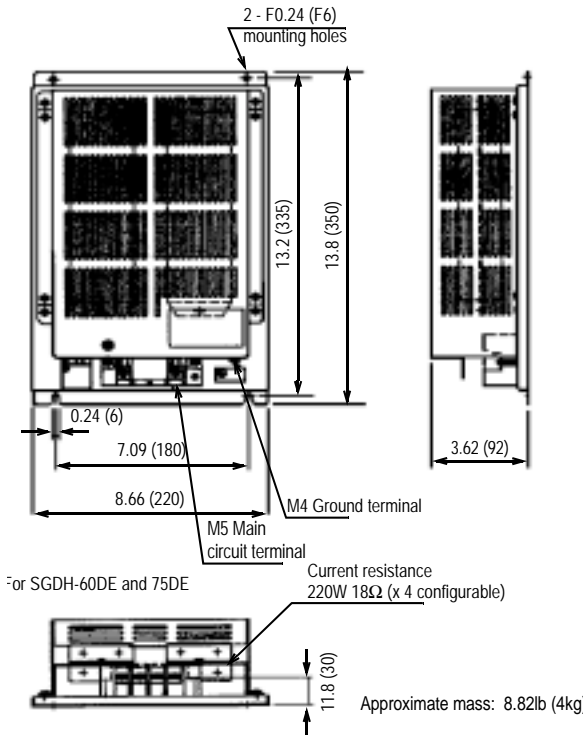

External Regenerative Resistors

Regenerative resistors for servo amplifiers are internally or externally mounted, as shown in the following table. They can be mounted externally on all servo amplifiers, but are especially effective when regenerative energy exceeds the servo amplifier's capacity.

When mounted externally, be sure to remove the jumper between B2 and B3, which deactivates the internal regenerative resistor.

Important: External regeneration resistor sizing and amplifier set-up will be important for proper operation.

Use Yaskawa's SigmaSize and the *Sigma II Series Servo System User's Manual: YEA-SIA-S800-32.2*

• Type JUSP-RA19

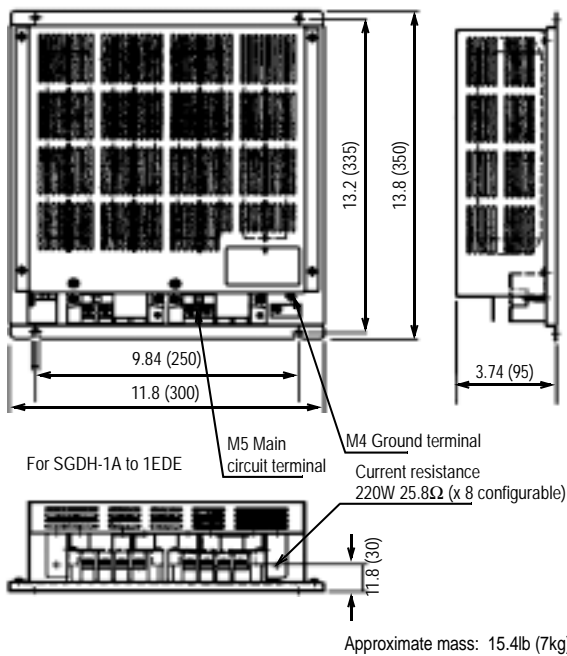

Applicable Servo Amplifier	Regenerative Resistor Mounted in a Servo Amplifier		Internal Regeneration Power Capacity (W)	Minimum Allowable Resistance (Ω)	
	Resistance (Ω)	Wattage* (W)			
400V Three-phase	SGDH-05DE	108	70	14	
	SGDH-10DE				
	SGDH-15DE				
	SGDH-20DE	45	140	28	44
	SGDH-30DE				
	SGDH-50DE	32	180	36	28
	SGDH-60DE	18**	880**	180	18
	SGDH-75DE				
	SGDH-1ADE	14.25***	1760***	350	14.2
SGDH-1EDE					

* Capacity prior to derating. If regeneration power requirements exceed internal capacity of the amp, install an external regeneration resistor (reference: Minimum allowable resistance). Be sure to derate wattage of external resistor to 20% or less (natural convection) and of 50% or less with forced air cooling.

** Provided externally by JUSP-RA18

*** Provided externally by JUSP-RA19

DB Units (For large capacity servo systems)

Externally attach a DB unit to the servopack.

This DB unit is used for dissipating motor EMF energy.

The DB unit does not need to be installed if the dynamic brake function is not required.

- **Specifications**

Use one of the following DB units according to the servopack model.

Servopack Model SDGH-	2BDE	3ZDE	3GDE	4EDE	5EDE
Regenerative DB Unit JUSP-	DB03		DB04	DB05	DB06
DB contactor and surge absorption unit	Built into servopack		Built into DB unit		
Resistance	0.8Ω				
Resistance Capacity	180W				300W
Allowable Load Moment of Inertia	5 times the load moment of inertia at motor shaft.				
Allowable Duty	Less than 1 time/H at maximum speed DB operation.				

- JUSP-DB03 Dynamic Brake Unit

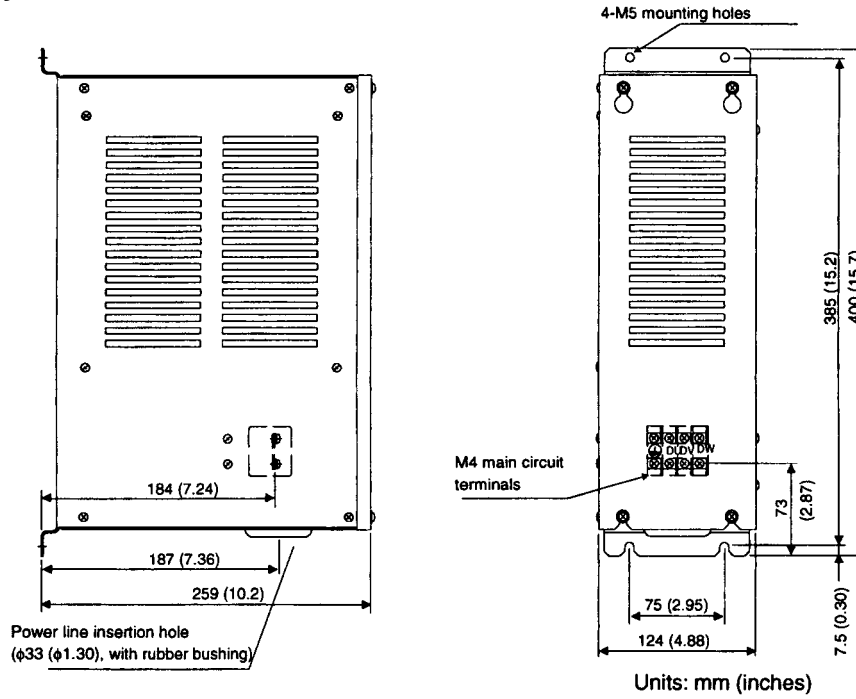

- JUSP-DB04 Dynamic Brake Unit

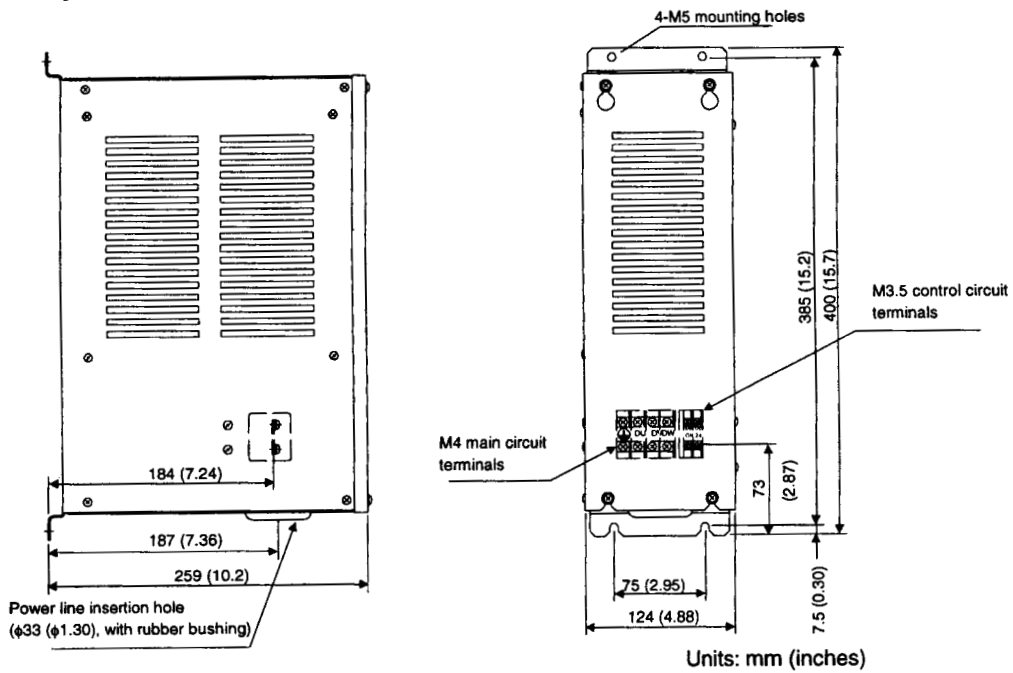

- JUSP-DB05 Dynamic Brake Unit

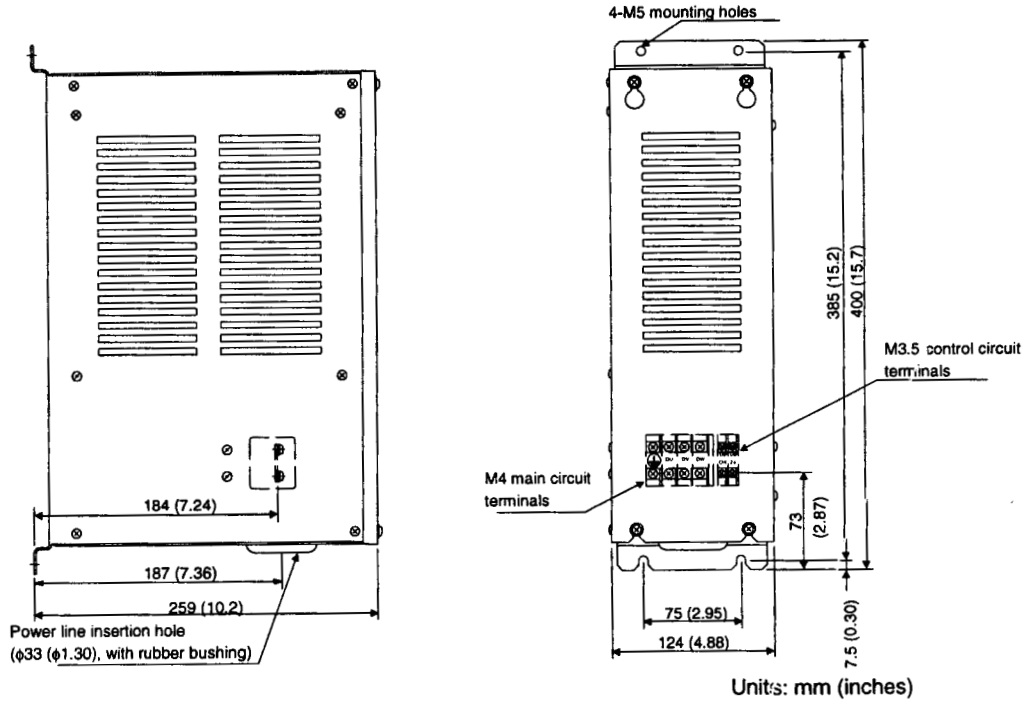

- JUSP-DB06 Dynamic Brake Unit

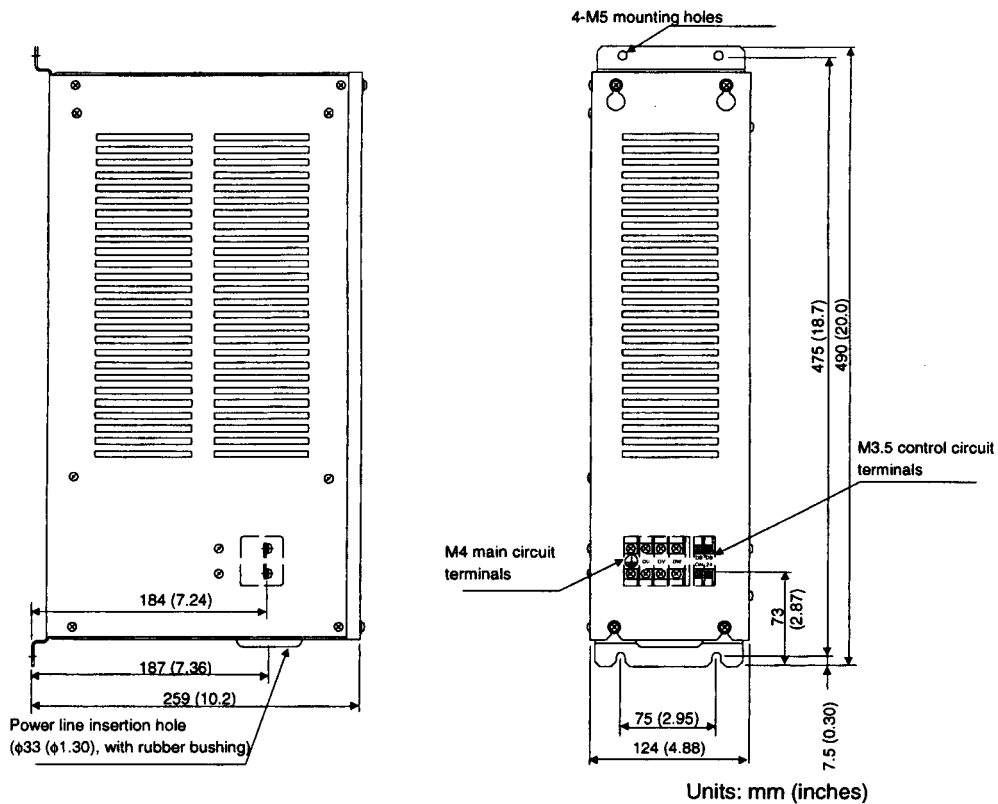

Control of Harmonic Frequency in the Power Supply Circuit

If harmonic frequency control is needed in the power supply, connect a DC reactor between terminals (+) 1 and (+) 2 on the servo amplifier's main circuit. Use the following table as a guide for selection of the appropriate reactor.

Applicable Servo Amplifier		Reactor Specifications		Reactor Model
		Impedance (mH)	Rated Current (A)	
400V	SGDH-05DE	4.7	1.5	X5074
	SGDH-10DE	3.3	4.5	X5075
	SGDH-15DE			
	SGDH-20DE	2.2	8.6	X5076
	SGDH-30DE			
	SGDH-50DE	1.5	14.1	X5077
	Larger size amplifiers	—	—	Consult factory for availability

• DC Reactor Dimensional Drawings

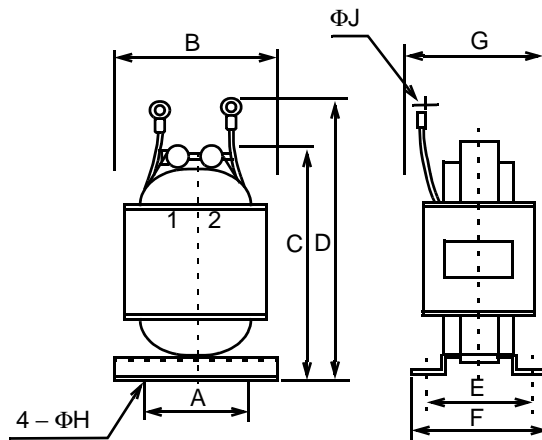

Reactor Model	Dimensions in (mm)									Approximate Mass lb (kg)
	A	B	C	D	E	F	G	ΦH	ΦJ	
X5074	1.18 (30)	1.85 (47)	2.76 (70)	3.35 (85)	1.10 (28)	1.50 (38)	1.77 (45)	0.16 (4)	0.17 (4.3)	0.661 (0.3)
X5075	1.57 (40)	2.32 (59)	3.94 (100)	4.72 (120)	1.57 (40)	1.97 (50)	2.17 (55)			1.984 (0.9)
X5076	1.97 (50)	2.91 (74)	4.92 (125)	5.51 (140)	1.38 (35)	1.77 (45)	2.36 (60)	0.20 (5)		2.43 (1.1)
X5077	Consult factory									

Typical Internal Connection Diagrams

• 400V, 0.5kW to 3.0kW Models

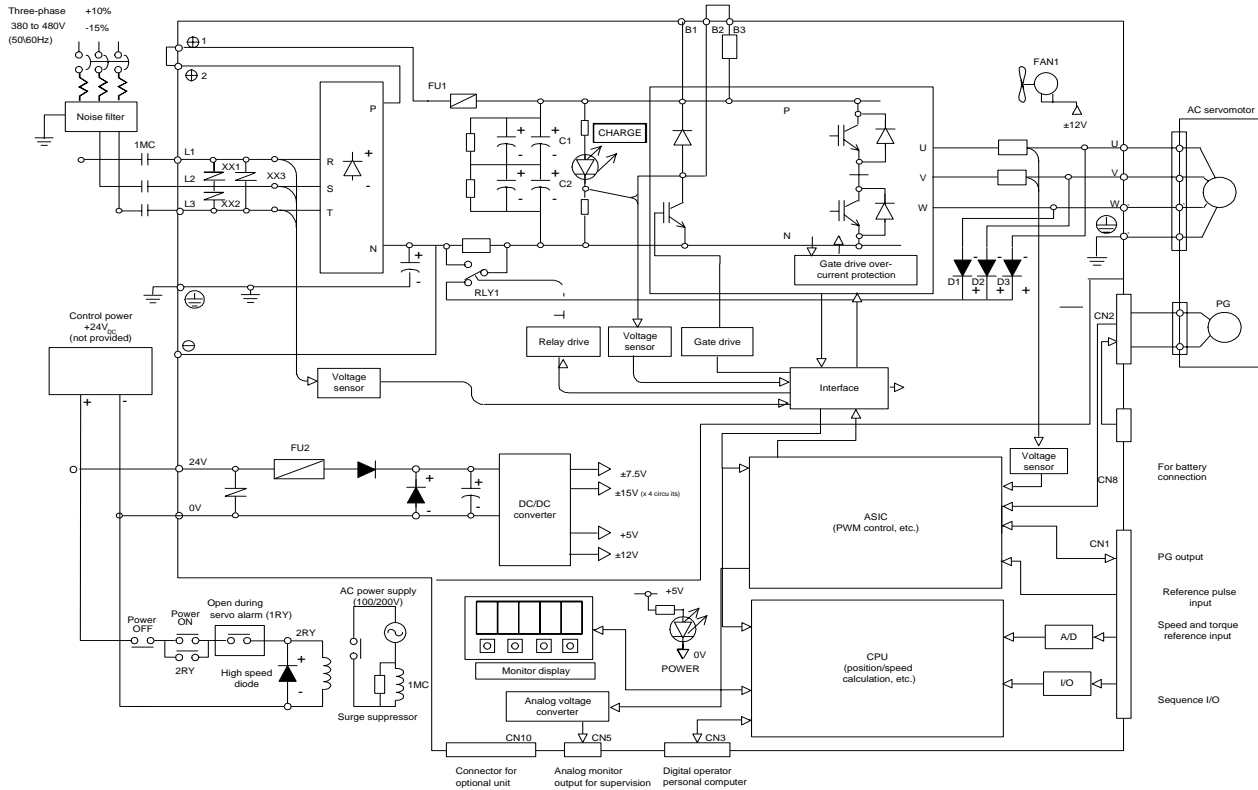

• 400V, 5.0kW Models

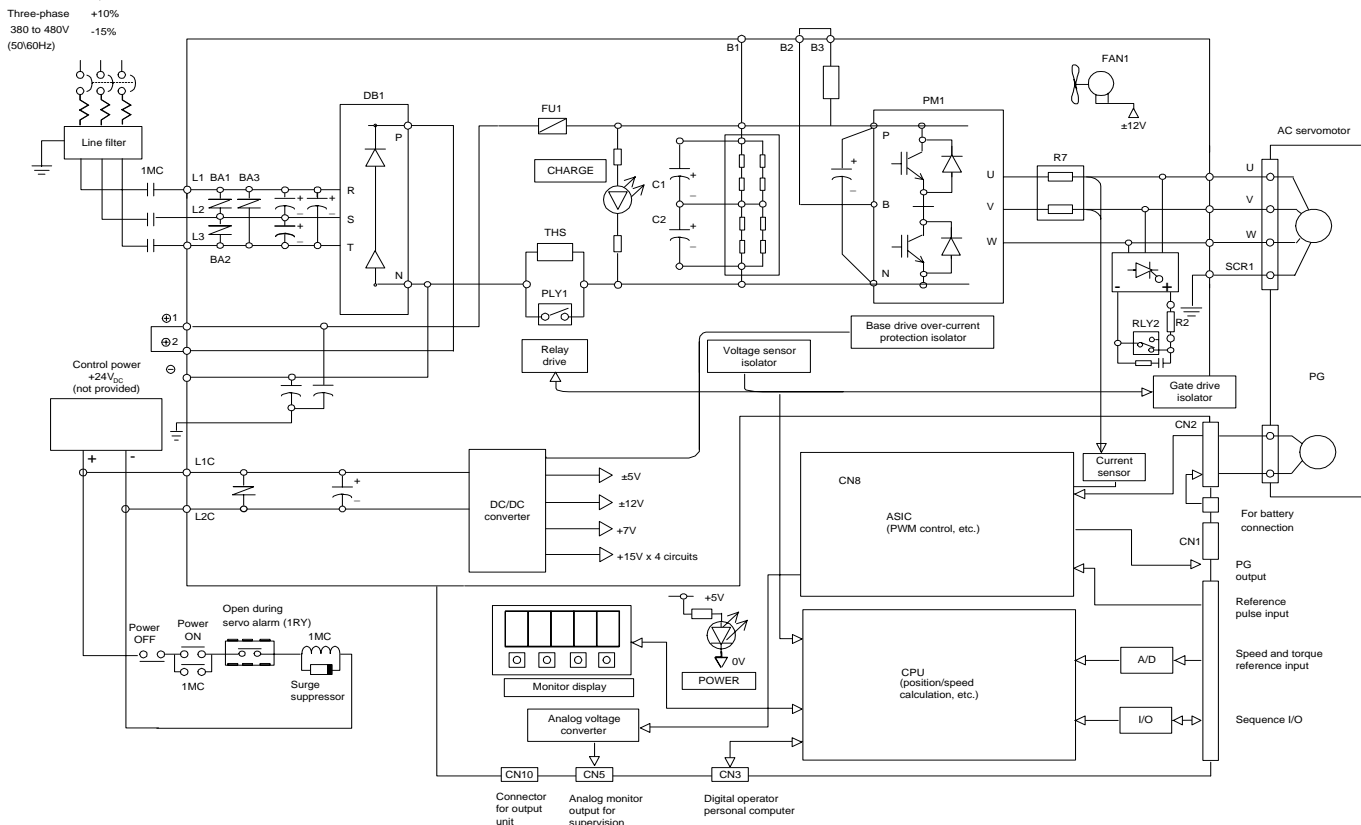

SGDH
Servo Amplifiers

400V Sigma II Servo Systems

- 400V, 6.0W to 7.5kW Models

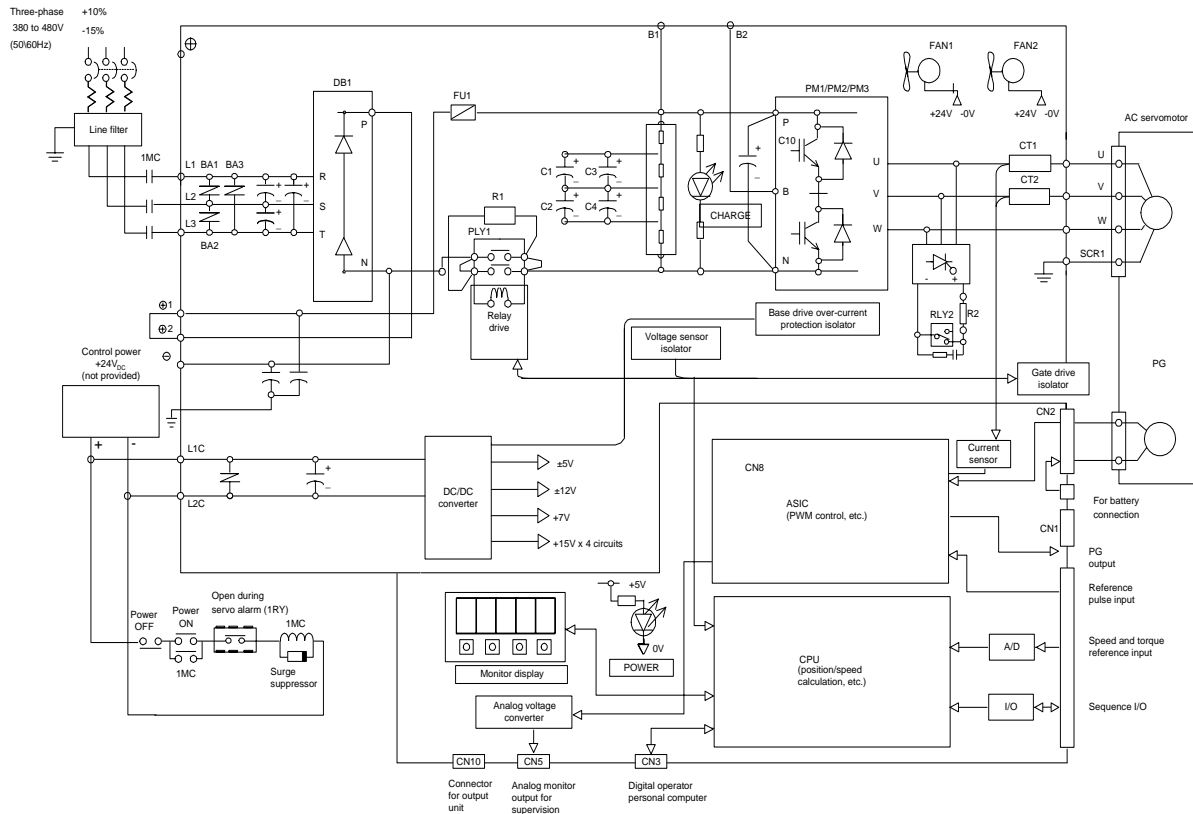

- 400V, 500W to 15kW Models

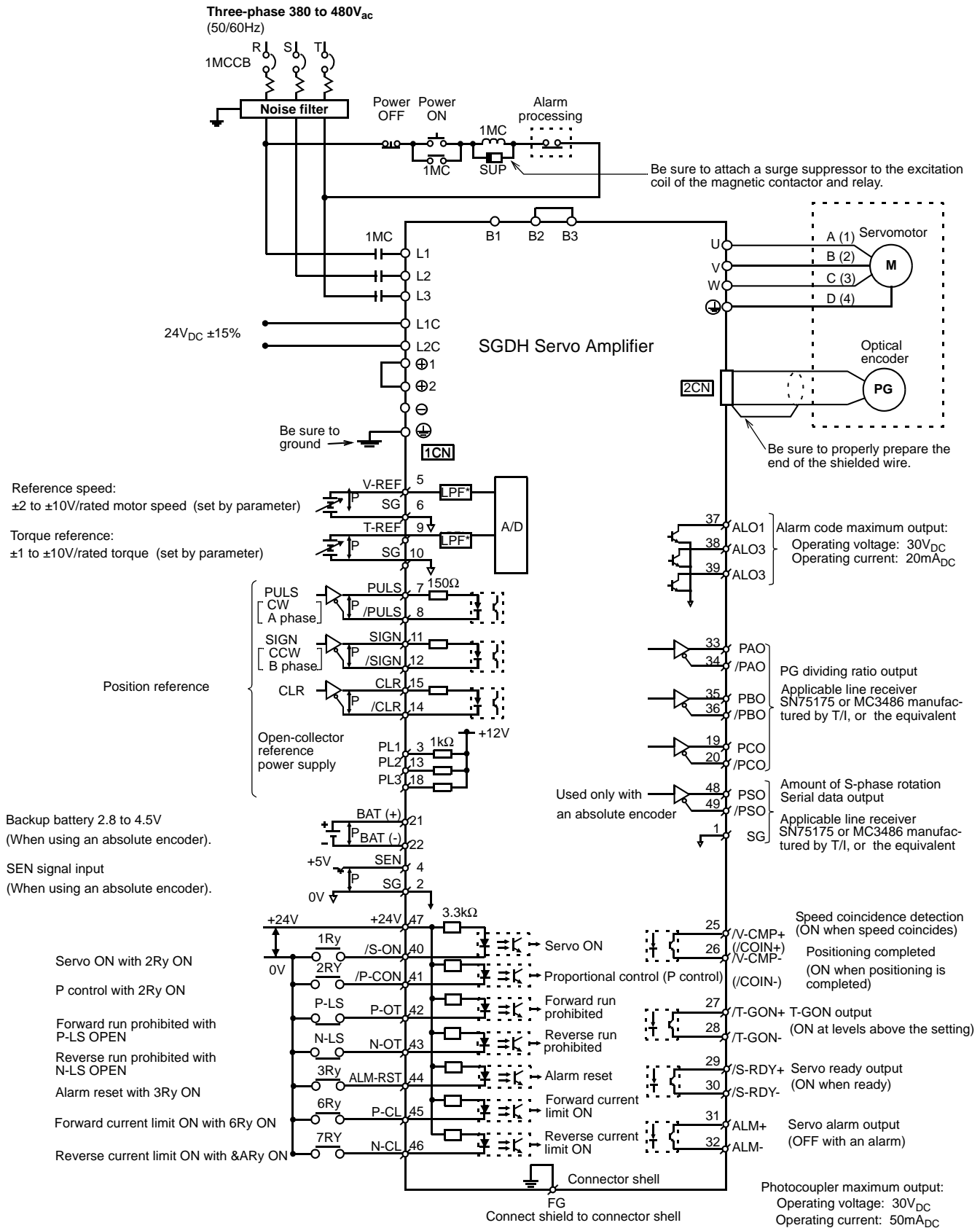

*The time constant for the primary filter is 47μs

†P: Indicates twisted wire pairs.

SGDH Servo Amplifiers

400V Sigma II Servo Systems

- 400V, 22kW to 30kW Models

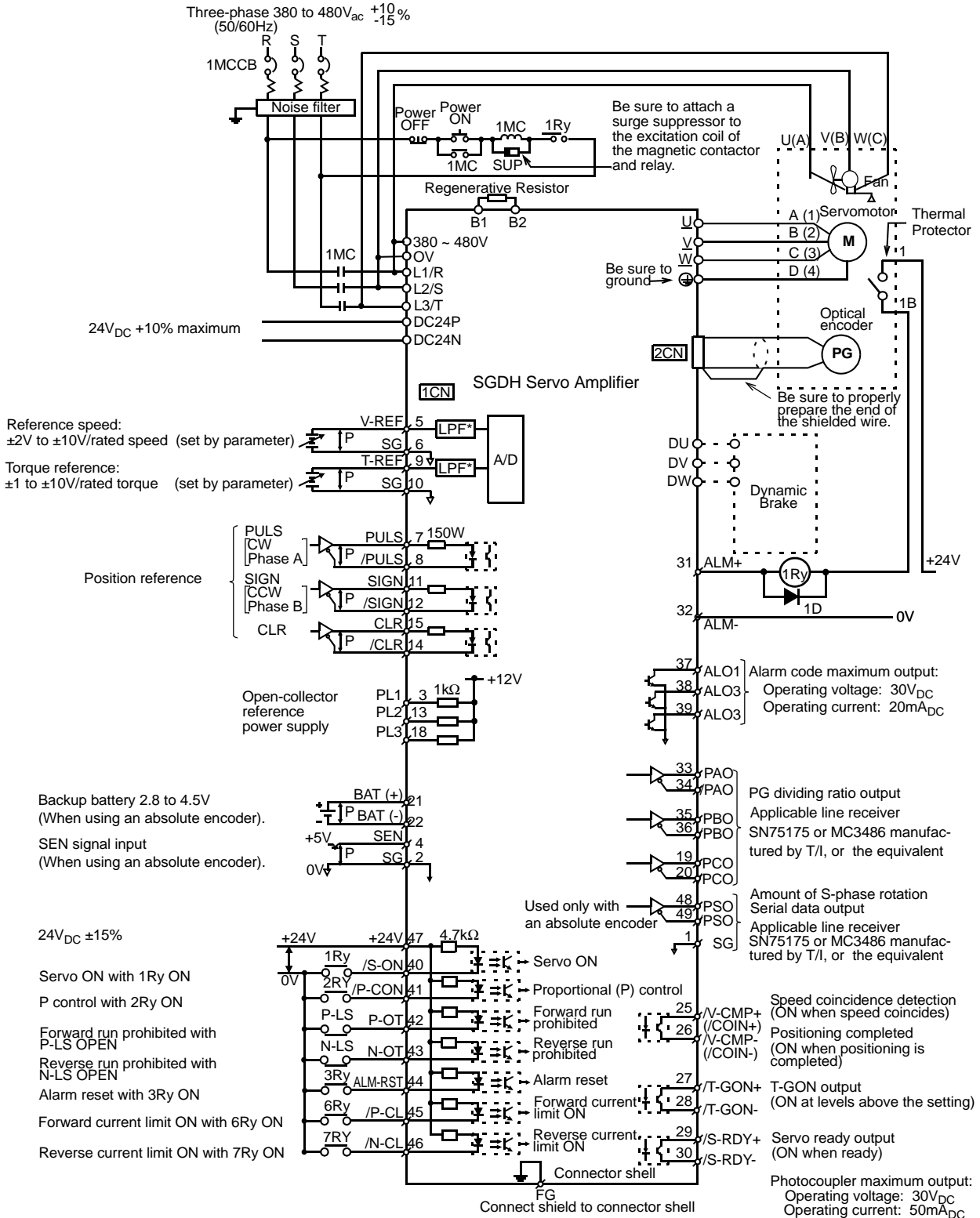

*The time constant for the primary filter is 47μs

⌋P: Indicates twisted wire pairs.

- 400V, 37kW to 55kW Models

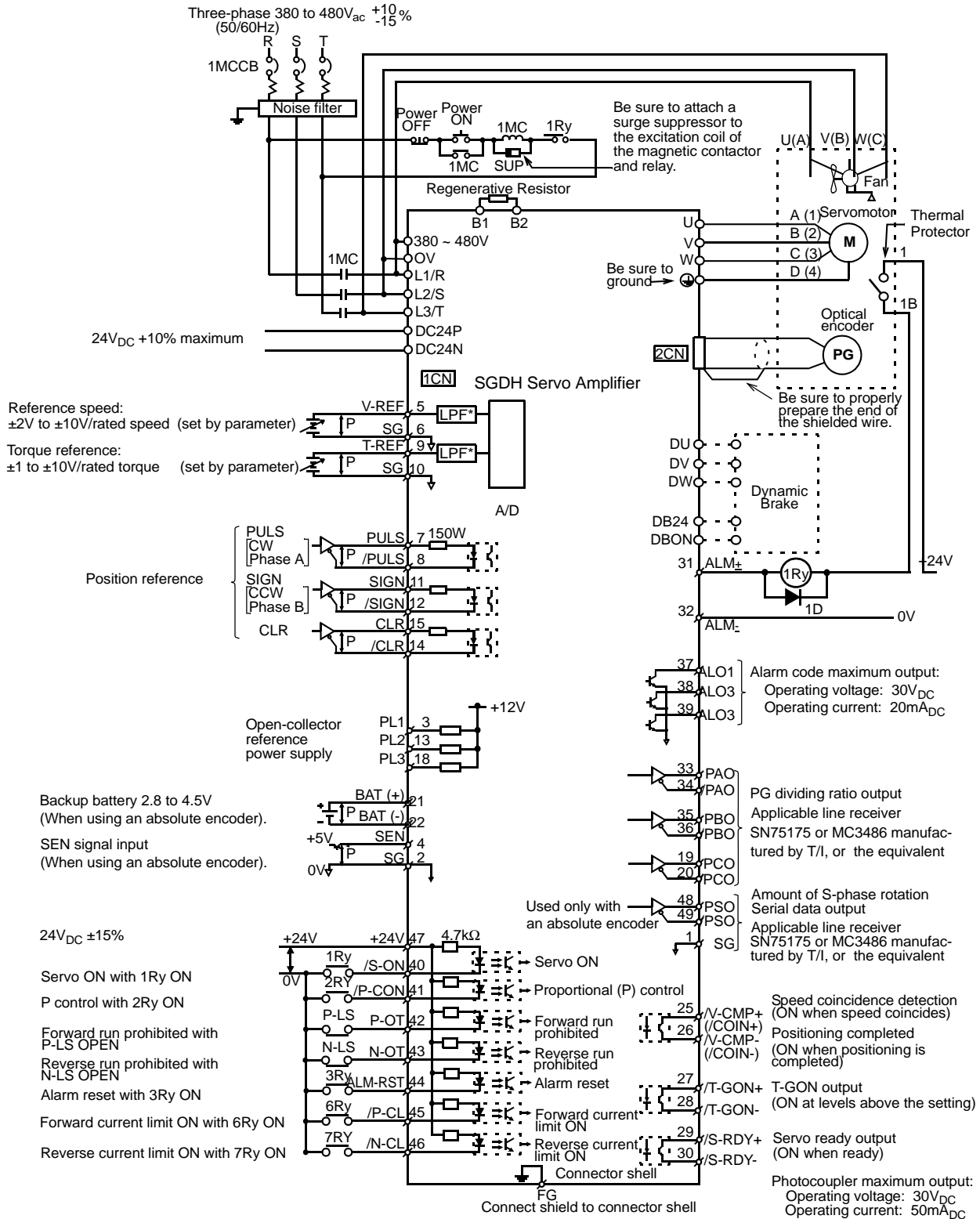

*The time constant for the primary filter is 47 μ s

⌈P: Indicates twisted wire pairs.

SGDH Servo Amplifiers

Connector Terminal Block Converter Unit JUSP-TA50P

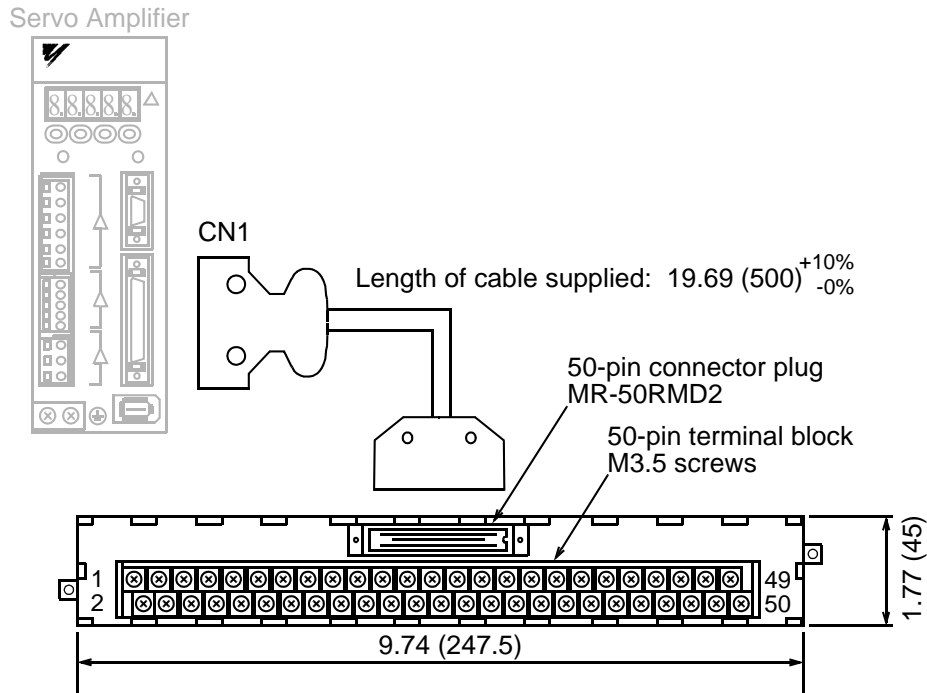

Connector Terminal Block Converter Unit
JUSP-TA50P* (cable included)

Mounting Hole Diagram

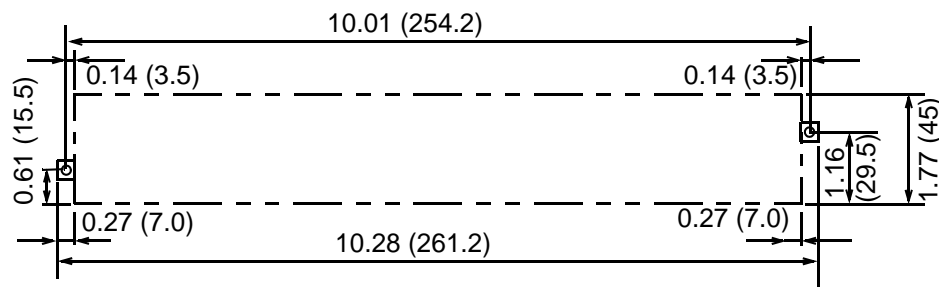

*terminal specifications : see the following page

JUSP-TA50P Terminal Block Pin Numbers and Signal Names

SGDH Servo Amplifier			JUSP-TA50P Terminal Block Unit		
Signal Name*		CN1 Pin Number		Connector Number	Terminal Block Number
SG		1		A1	1
SG		2		B1	2
PL1		3		A2	3
SEN		4		B2	4
V-REF		5		A3	5
SG		6	↑P	B3	6
PULS		7		A4	7
/PULS		8	↑P	B4	8
T-REF		9		A5	9
SG		10	↑P	B5	10
SIGN		11		A6	11
/SIGN		12	↑P	B6	12
PL2		13		A7	13
/CLR		14		B7	14
CLR		15	↑P	A8	15
		16		B8	16
		17		A9	17
PL3		18		B9	18
PCO		19		A10	19
/PCO		20	↑P	B10	20
BAT (+)		21		A11	21
BAT (-)		22	↑P	B11	22
		23		A12	23
		24		B12	24
V-CMP+		25		A13	25
V-CMP-		26	↑P	B13	26
/TGON+		27		A14	27
/TGON-		28	↑P	B14	28
/S-RDY-		29		A15	29
/S-RDY-		30	↑P	B15	30
ALM+		31		A16	31
ALM-		32	↑P	B16	32
PAO		33		A17	33
/PAO		34	↑P	B17	34
PBO		35		A18	35
/PBO		36	↑P	B18	36
ALO1		37		A19	37
ALO2		38		B19	38
ALO3		39		A20	39
S-ON		40		B20	40
/P-CON		41		A21	41
P-OT		42		B21	42
N-OT		43		A22	43
/ALM-RST		44		B22	44
/P-CL		45		A23	45
/N-CL		46		B23	46
+24V IN		47		A24	47
PSO		48		B24	48
/PSO		49	↑P	A25	49
		50		B25	50

Cable: Supplied with the terminal block

↑P: Indicates twisted pair wires.

* Preconfigured amplifier inputs and outputs are listed above as they are designated when the unit is shipped from the factory. Use the connection diagrams on the previous pages for more functional details.

Amplifier to Encoder Connection Diagram

Connection Example

The following diagrams show the procedure for wiring a servo amplifier to an encoder.

Connecting an encoder (CN2) and output signals from the servo amplifier (CN1)

Incremental Encoders

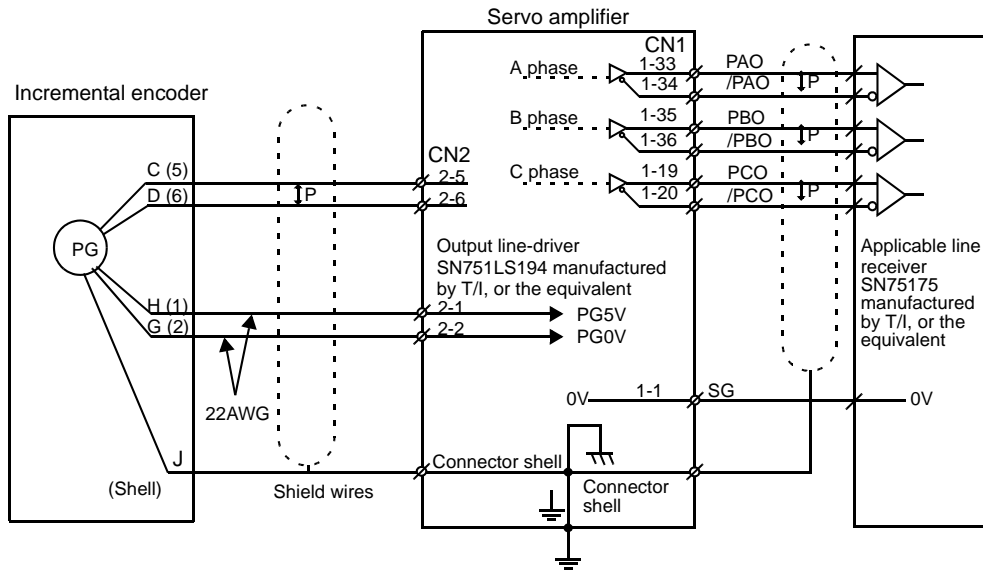

Absolute Encoders

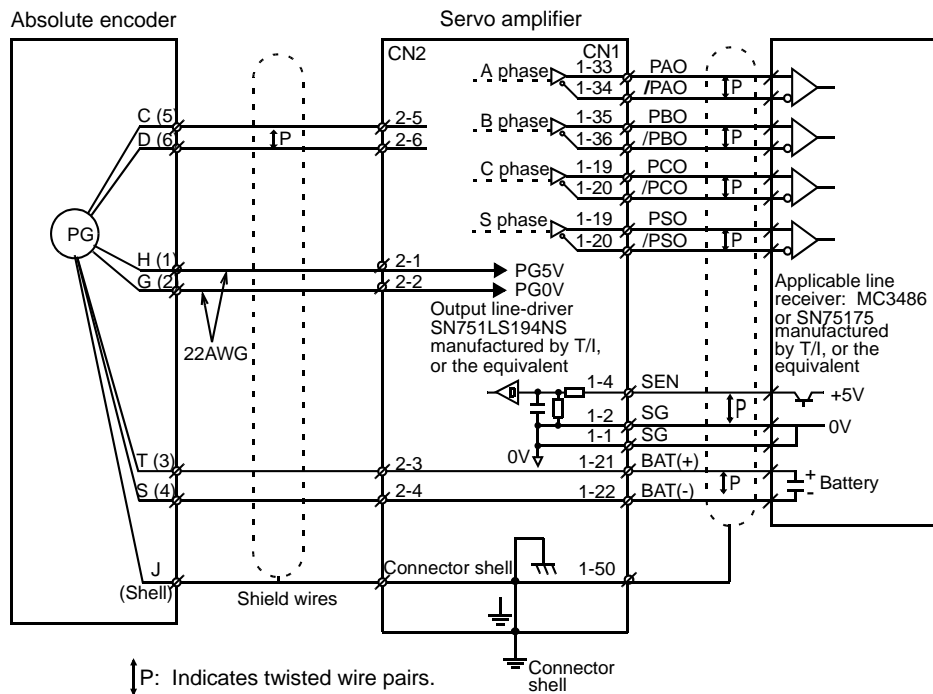

↑P: Indicates twisted wire pairs.

Overload Characteristics

Servo amplifiers have a built-in overload protection function that protects the servo amplifiers and servo motors from overload. Allowable power for the servo amplifiers is limited by the overload protective function, as shown in the figure below.

The overload detection level is set under hot start conditions at a servomotor ambient temperature of 40°C.

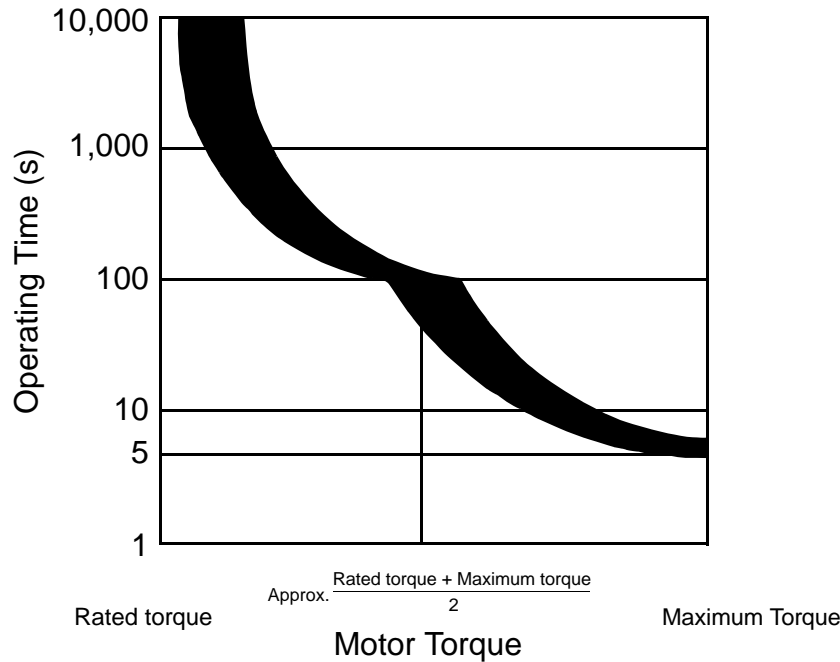

Note: The overload protection characteristics in the figure are applicable when the servo amplifier is combined with one of the following servomotors:

SGMGH
SGMSH
SGMUH
SGMBH

Cable Specifications and Peripheral Devices

Ratings and specifications for peripheral devices, as well as cable specifications for servo amplifiers are summarized in the tables below.



CAUTION

Wiring Precautions

- **Do not bundle or run power and signal lines together in the same duct.**
Keep power and signal lines at least 11.81" (30cm) apart.
- **Use twisted pair or shielded multi-core twisted pair wires for signal and encoder (PG) feedback lines.**
- **The maximum lengths for signal lines are as follows:**
 - Maximum of 9.84ft (300cm) for reference input lines.
 - Maximum of 65.6ft (20m) for PG feedback lines.

Cable Specifications

The following table provides wire size specifications:

External Terminal Name		SGDH Terminal Symbol	Wire Size AWG [in ² (mm ²)]				
			05DE	10DE	15DE	20DE	30DE
for 400V	Main circuit power input terminals	L1, L2, L3 (Three-phase)	16 AWG [HIV 0.0019 (1.25)]			14 AWG [0.003 (2.0)]	
	Servomotor connection terminals	U, V, W					
	Control power supply terminals	L1C, L2C	16 AWG [HIV 0.0019 (1.25)]				
	Control I/O signal connector	CN1	Twisted pair or shielded twisted pair wires Core wire at least 28 AWG [0.0002 (0.12)], tinned, annealed copper twisted wires. See page 198 for details. Finished cable dimensions: maximum Φ 0.63in (16mm) for CN1 and Φ 0.27in (6.8mm) for CN2.				
	PG signal connector	CN2					
	Ground terminal		14 AWG [HIV 0.003 (2.0)]				

External Terminal Name		SGDH Terminal Symbol	Wire Size AWG [in ² (mm ²)]				
			50DE	60DE	75DE	1A DE	1E DE
for 400V	Main circuit power input terminals	L1, L2, L3 (Three-phase)	HIV 3.5 (0.005)		HIV 5.5 (0.009)	HIV 8 (0.012)	HIV 14 (0.022)
	Servomotor connection terminals	U, V, W	HIV 3.5 (0.005)	HIV 5.5 (0.009)	HIV 5.5 (0.009)	HIV 8 (0.012)	HIV 14 (0.022)
	Control power supply terminals	L1C, L2C	16 AWG [HIV 0.0019 (1.25)]				
	Control I/O signal connector	CN1	Twisted pair or shielded twisted pair wires Core wire at least 28 AWG [0.0002 (0.12)], tinned, annealed copper twisted wires. See page 198 for details. Finished cable dimensions: maximum Φ 0.63in (16mm) for CN1 and Φ 0.27in (6.8mm) for CN2.				
	PG signal connector	CN2					
	Ground terminal		14 AWG [HIV 0.003 (2.0)]				

External Terminal Name		SGDH Terminal Symbol	Wire Size AWG [in ² (mm ²)]				
			2BDE	3ZDE	3GDE	4EDE	5EDE
for 400V	Main circuit power input terminals	⊕ L1/R, L2/S, L3/T	6AWG [HIV 0.022 (14)]		4AWG [HIV 0.034 (22)]	2AWG [HIV 0.046 (30)]	1AWG [HIV 0.059 (38)]
	Servomotor connection terminals	⊕ U, V, W	6AWG [HIV 0.022 (14)]	4AWG [HIV 0.034 (22)]	2AWG [HIV 0.046 (30)]	1AWG [HIV 0.059 (38)]	1AWG [HIV 0.077 (50)]*
	Control power supply terminals	DC24P, DC24N	18 AWG [HIV 0.0015 (1.0)]				
	Heatsink fan power	380~480V, OV	18 AWG [HIV 0.0015 (1.0)]				
	Fan power terminals	⊕ U(A), V(B), W(C)	18 AWG [HIV 0.0015 (1.0)]				
	Regenerative resistor connector	B1, B2	14 AWG [HIV 0.003 (2.0)]				
	Dynamic brake power connector	DU, DV, DW	16 AWG [HIV 0.002 (1.25)]				
	Dynamic brake control power	DB24, DBON	16 AWG [HIV 0.002 (1.25)]				

*The larger dimension falls within the limits of 1AWG.

- Notes:
1. Wire sizes were selected for three cables per bundle at 40°C ambient temperature with the rated current.
 2. Use cables with a minimum withstand voltage of 600V for main circuits.
 3. If cables are bundled in PVC or metal ducts, consider the reduction ratio of the allowable current.
 4. Use heat-resistant cable under high ambient or panel temperatures where normal vinyl cable will rapidly deteriorate.

The following table shows types of cables. It is used in conjunction with the preceding tables.

Cable Type		Temperature Rating of Conductor °C
Name	Composition	
PVC	Standard polyvinyl chloride cable	-
IV	600V PVC cable	60
HIV	Temperature-resistant vinyl cable	75

400V Sigma II Servo Systems

The following table specifies the cables for CN1 and CN2 servo amplifier connectors.

Wire sizes were selected with the expectation of three cables per bundle, at an ambient temperature of 40°C, at the rated current level.

Connector Name	Signal	Description	Specification
Control I/O Signal Connector	CN1	Cable	Use twisted pair or shielded twisted pair wire.
		Applicable wire	(AWG): 24, 26, 28
		Finished cable Dimension	Φ0.63 (Φ16.0) maximum
PG Signal Connector	CN2	Cable	Use Yaskawa cable, or shielded twisted pair wire.
		Applicable wire	(AWG): 22, 24, 26 Use 22 AWG [0.0005 (0.34)] for the encoder power supply and 26 AWG [0.0002 (0.14)] for other signals. These conditions permit wiring distances up to 65.6ft (20m).
		Finished cable Dimension	Φ0.27 (Φ6.8) maximum

Peripheral Device Types and Capacities

Main Circuit Power Supply	Amplifier Model		Control Power Required (W)	Applicable Servomotor	Power Supply				Recommended Noise Filter**		Motor Magnetic Contactor
	Capacity (kW)	SGDH-			Capacity per Servo Amplifier (kVA)	Rated Input (A _{rms})	Maximum Inrush Current (A _{rms})	MCCB or Fuse Capacity* (A _{rms})	Model	Specifications	
Three-phase 400V	0.45	05DE	15	SGMGH-05D□A	1.2	2.0	28	1.7	Fn258L-7/07 (or FS5826-6-07)	Three-phase 480V _{ac} 7A (6A)	10A or equivalent
	1.0	10DE		SGMGH-09D□A	2.3	3.5		3.4			
				SGMSH-10D							
	1.5	15DE		SGMUH-10D	3.2	4.8	4.6				
				SGMGH-13D□A							
	2.0	20DE		SGMGH-20D□A	4.9	6.0	7.1				
				SGMSH-20D							
	3.0	30DE		SGMGH-30D□A	6.8	8.5	9.8				
				SGMSH-30D							
				SGMUH-30D							
	5.0	50DE		SGMGH-44D	10.3	14.9	58	14.9	FS5559-35/33 (or FS5827-30-07)	Three-phase 480V _{ac} 35A (30A)	40A or equivalent
	6.0	60DE		SGMSH-50D	12.4	17.8	93	17.8			
	7.5	75DE	SGMGH-75D	15.4	22.3	22.3					
	11.0	1ADE	SGMGH-1AD	22.6	32.7	116	32.7	FS5559-80/34 (or FS5826-55-07)	Three-phase 480V _{ac} 80A (55A)	75A or equivalent	
			15.0	1EDE	SGMGH-1ED		30.9				44.6
22.0	2BDE	150	SGMBH-2B	36.7	53	162	100	Fn258L-75-34	Three-phase 480V _{ac}	100A or equivalent	
30.0	3ZDE		SGMBH-3Z	50.1	72	650	150	Fn258L-100-35	Three-phase 480V _{ac}	150A or equivalent	
37.0	3GDE		SGMBH-3G	61.8	89			Fn258L-130-35			
45.0	4EDE		SGMBH-4E	75.2	109	1300	225	Fn258L-180-7	Three-phase 480V _{ac}	225A or equivalent	
55.0	5EDE		SGMBH-5E	91.9	133						

* Size per local code requirements . Typical fuse interrupting characteristics at 25°C: 200% for 2s minimum; 700% for 0.01s minimum.

** The Fnzzzz noise filter is manufactured by Schaffner Corporation. Specifications are available at: www.schaffner.com

Peripheral Device Manufacturers

J.S.T. Corporation

1957 South Lakeside Drive
Waukegan, Illinois 60085

Phone: (847) 473-1957
<http://www.jst.com>

Molex (Headquarters)

(Note: not selling 2CN serial
encoder connector in the US)
2222 Wellington Court
Lisle, Illinois 60532

Phone: (630) 527-4474
Fax: (630) 548-2897

(Connector information is not
available from Molex or Yaskawa)

For literature requests or Molex
support for the 2CN connector,
the Chicago area distributor is TTI
Ask for the Yaskawa inside sales
representative.

1-800-CALLTTI
(1-800-225-5884)

Schaffner EMC Inc.

52 Mayfield Ave.
Edison, New Jersey 08837

Phone: 1-800 367-5566
(732) 225-9533
Fax: (732) 225-4789
<http://www.shaffner.com>

TDK Corporation of America

1600 Feehanville Dr.
Mount Prospect, Illinois 60056

Phone: (847) 803-6100
Fax: (847) 803-6296

Tokin America

32950 Alvarado-Niles Rd.
Suite 500
Union City, California 94507

Phone: (510) 324-4110
Fax: (510) 324-1762
<http://www.tokin.com>

NOTES:



Yaskawa . . . A World of Automation Solutions



Yaskawa Electric America, Inc.
Chicago-Corporate Headquarters
2121 Norman Drive South
Waukegan, Illinois 60085
1-800-YASKAWA
<http://www.yaskawa.com>

Yaskawa Electric Europe
Am Kronberger Hang 2, 65824
Schwalbach, Germany
49-6196-569-300
<http://www.yaskawa.de>

Yaskawa Electric Corporation
New Pier Takeshiba
South Tower, 1-16-1 Kaigan
Minatoku, Tokyo 105 Japan
81-3-5402-4511
<http://www.yaskawa.co.jp>