

2008/2009

Fans and Blowers

GENERAL CATALOGUE

DC Axial Fans

DC Centrifugal Blowers

Variable-speed Fans and Blowers

Customized Fans and Blowers

AC Fans and Blowers

TEMPORARY





Fans & Blowers



CONTENTS

Contents	G-1
Catalog Information	G-2
Product Features of NIDEC SERVO Co.	G-3
Motor Selection Guide	G-4
Technical Data	G-6
DC Axial Fans	G-16
Gentelyphoon™ (NEW)	G-20, G-23
Fixed Blade Type DC Axial Fans (NEW)	G-31
(For a high static pressure region Fans G series)	
DC Centrifugal Blowers	G-37
Variable-speed Fans and Blowers	G-51
Customized Fans and Blowers	G-52
AC Fans and Blowers	G-55
Guards, Filters and Plug Cords (Options)	G-64

- Please visit our website for any technical inquiries or information.
- For non-technical inquiries, contact our local NIDEC SERVO sales office or distributor in your area.
- This catalog contains only the latest standard products in the inventory and semi-standard products.
Contact your NIDEC SERVO sales office or distributor for details about customized and semi-customized products.
- Please visit our website for specifications and other information on former products release.
- The dimensions, specifications, and components contained in this catalog are subject to change without prior notice due to further product improvements.
- Contact NIDEC SERVO Co. or a distributor if you wish to obtain product samples.

■ Catalog Information Guide

The descriptions of the AC and DC fans and blowers appear on the product pages as shown below. Contact NIDEC SERVO if clarification or further information is desired.

Lineup of standard products and basic characteristics.

Fan/blower noise in free air state. (Static pressure 0 Pa)
(This value is sometimes considerably higher when the fan or blower is installed in your equipment. See pages G-8 to G-10)

Operable voltage range. (PQ characteristics vary depending on the operating voltage. See page G-7)

Startup current value. (Use to select the power source)

Current value in free air state. (The current at the operating point will be an increment of 20 % or less of the rating with fans and will be below the rating with blowers. See page G-13)

Important notes regarding the basic characteristics.

List of products which do not meet the standard life.

Flange shape. (Select ribbed specification when screws are used)

External dimensions, lead wire specifications.

Mounting hole dimensions as examples for fan mounting. (Recommended shapes to maximize fan performance characteristics)

Customizing, safety standards, 3D data.

Product photo, maximum performance, weight.

List of model codes. (Product codes for which orders are accepted)

Materials used, carton specification.

PQ characteristics chart. (Drawing an estimated ventilating resistance curve will determine the airflow at the operating point)

Wiring connection to the power source. (See page G-15 for the wiring connection to the sensors)

List of fans and blowers with sensors.

Brushless DC Fans & Blowers **KUDC Series** 92 × 25 mm

DC Axial Fans **KUDC**

Standard specification (Lead wire type)

Max. airflow m³/min	CFM	Max. static pressure Pa	Max. static pressure inH ₂ O	Noise dB	Speed r/min	Input W	Voltage spec. Rated	Voltage spec. Use	Current mA	Model code	Operating temp. range °C
1.8	64	70	0.28	41.5	3450	4.2	12	7.2-13.8	350	KUDC12U7	-20 ~ +60
4.8	24	12-27.6	200	66	600	3.2	12	7.2-13.8	270	KUDC24U7	
1.66	59	60	0.24	39	3200	3.6	24	12-27.6	150	KUDC12H7	
3.6	24	12-27.6	140	320	320	3.0	12	7.2-13.8	250	KUDC12Z7	
3.3	24	12-27.6	140	320	320	3.3	24	12-27.6	140	KUDC24Z7	
1.55	55	52	0.21	37	2950	3.5	48	24-55.2	70	KUDC48Z7	-20 ~ +70
12	7.2-13.8	230	480			1.4	12	7.2-13.8	130	KUDC12B4	
12	7.2-13.8	130	240			2.9	24	12-27.6	60	KUDC24B4	
48	24-55.2	60	130			4.8	24	12-27.6	110	KUDC12D4	
1.4	49	43	0.17	34	2750	1.4	12	8.4-13.8	110	KUDC12D4	
1.3	24	14.4-27.6	60	110		1.3	24	14.4-27.6	60	KUDC24D4	
35	24	0.10	26	1950							

General specification

Materials used: Venturi: ABS and PBT synthetic resins
Propeller: ABS and PBT synthetic resins
Bearing: Both side shielded ball bearing

Motor: Brushless DC motor, Protection type: Current shut off by detecting lock state, automatically reset

Common elec. spec.: See pages G-11 and 12.

Standard crate: 70 to a crate of (450 × 380 × 300) mm, mass 7 kg

Standard airflow and static pressure characteristics (At rated voltage)
[By double chamber method]

Wiring connection diagram

axial fan with sensor

Rated vol.	Model code
12V	KUDC12D4S
	KUDC12B4S
	KUDC12Z7S
	KUDC12H7S
24V	KUDC24D4S
	KUDC24B4S
	KUDC24Z7S
	KUDC24H7S
48V	KUDC48B4S
	KUDC48B4S
	KUDC48B4S
	KUDC48Z7S

External dimensions in mm (inches)

Lead wire type: Lead wire spec. AWG24 UL1007 or UL3266
Color: (1) Red (2) Black (KUDC12H, 12Z, 12B, 12H)
(3) Blue (KUDC24H, 24Z, 24B, 24H)

Mounting hole dimensions in mm (inches)
[example]

Options (sold separately):
- Guard: F30LE guard
- Filter: F30 filter
- Spacer: Flange spacer KUDC

Notes:
- Japan Servo will gladly respond to customizing requirements, including connector processing to lead wire terminals, models with a sensor other than those listed above and variable-speed specification. Contact Japan Servo during the product planning/development stage.
- The listed products are registered in the following overseas standards files: UL, ENEC, CSA, IEC60950, TUV, RoHS1500.
- A further electronic catalog of Japan Servo Co. that will be forwarded upon request, and the "web2-CAD site" (<http://www.web2cad.co.jp/>) contain 3D data.

G-2

www.nidec-servo.com 2008/2009

High customer satisfaction achieved thanks to our quiet and energy efficient products with unsurpassed reliability and customizability.

Focusing on product development for computer related equipment, the compact axial fans from NIDEC SERVO are the result of technological innovations that minimize noise to the greatest possible extent.

NIDEC SERVO's product designs incorporate several industry firsts, including specially molded 3-dimensional blades, and GentleTyphoon fans with a unique blade shape. Market requirements are always researched and catered to in advance; meaning customers always receive products that perform well ahead of market rivals.

**● Versatile lineups of axial fans and centrifugal blowers
Fans for high static pressure applications are also supplied as standard products.**

The aerodynamic characteristics required for fan motors differ depending on the equipment in which they are installed, but may roughly be grouped into airflow focus and pressure focus types respectively. The axial fans and centrifugal blowers (also called "centrifugal fans" and "sirocco fans"), as fan motors of NIDEC SERVO, fall into both the former and latter categories. Recently, NIDEC SERVO has also developed pressure focus type axial fans, suitable for use in high static pressure regions, in response to diverse customer requirements.

As its name implies, an axial fan generates airflow in the motor axial direction. Airflow can be generated cylindrically by the propeller from the entire diameter of the fan, allowing considerable airflow generation. The axial fan sucks in air and pushes it out through the propeller blades, without large pressure (static pressure) output.

The centrifugal blower, on the other hand, recovers the airflow released by the impeller blades in a centrifugal direction from the motor shaft center via the scroll casing (also called a "housing" or "frame") and discharges it unidirectionally. This system effectively converts a centrifugal force into pressure, increasing the pressure (static pressure) to blow the air. However, only a limited airflow passes through the impeller, preventing a large airflow from being obtained.

NIDEC SERVO refers to the former as fans and the latter as blowers, to easily distinguish the differences between the two types.

In addition to these two types, NIDEC SERVO has recently released axial fans with features resembling those of the blower (high static pressure region fans, e.g. the G1751M series). These fans are attracting the attention of the IT industry and are highly rated as quiet products, capable of saving energy with high-impedance equipment, with which conventional axial fans have not been efficient.

● Our ceaseless quest to reduce noise

NIDEC SERVO continues to introduce a never ending series of quiet products to the market. People know to talk to NIDEC SERVO if low noise is a priority, and that reputation has grown over many years. Day and night, NIDEC SERVO is active in the research and development of low noise technology. NIDEC SERVO also swiftly introduced computational fluid dynamics (CFD) to deliver quiet fans and blowers that customers can use without worrying about designing noise reduction measures into their application.

● Versatile lineup of energy saving products

The power consumption of fans may be problematic with some high airflow products and with large fans and blowers. When several units are used, a high capacity power source must be installed. NIDEC SERVO markets a large variety of high-efficiency fan motors that can reduce the power capacity required for such machines.

● Only highly reliable products are delivered to customers

With product liability in mind, it is the logical responsibility of manufacturers to supply highly reliable products that can be used by customers without any product safety worries. Products with new designs are only supplied to the market after their viability has been verified by subjecting them to various reliability tests and proving that they are problem-free. Moreover, only high-reliability parts are used in the drive circuits of DC fans and blowers. NIDEC SERVO develops and designs products by specifying the strictest derating level in the industry.

● Customized and semi-customized product specifications

Products are supplied in optimum customized form for bulk purchases. NIDEC SERVO is capable of swiftly accomplishing optimum designs by fully exploiting CFD technology. NIDEC SERVO will propose optimum semi-customized fans and blowers by combining its large variety of customized parts. Let NIDEC SERVO devise a suitable solution to meet your requirements.

● All NIDEC SERVO catalog products conform to the EU RoHS Directive

All NIDEC SERVO products conform to the EU RoHS Directive by restricting the contents of six specified hazardous substances (lead, mercury, cadmium, hexavalent chromium, PBD and PBDE) to below tolerable values. (All products produced from the beginning of January 2006 meet the RoHS Directive. Certain standard inventory products may include those produced in and before December 2005. Please specify in your purchase orders that only RoHS-compliant products should be shipped.)

NIDEC SERVO is also active in reducing another 18 hazardous substances.



● AC and DC fans

One of the prominent advantages of AC fans is the fact that they can be directly connected to an AC power supply. The DC fan boasts high motor efficiency and is power-saving, as well as generating less heat, allowing the weight of the motor and venturi case to be reduced.

AC fans and blowers use AC induction motors and are suitable for constant speed operation. DC fans and blowers, meanwhile, use DC brushless motors and can have highly variable airflow. By varying the voltage supply, the speed is also easily adjustable. Standard DC fans and blowers regulated by variable-speed control are also available. See pages G-51 for further details.

[Principal applications]

- Computers and peripheral terminal equipment ● Servers
- Personal computers ● Copiers ● Audio equipment
- Broadcasting equipment ● Communication equipment
- Industrial equipment ● Medical equipment ● Game machines

<p>Fans</p> 	<p>Fan Characteristics</p> <ul style="list-style-type: none"> ● Large airflow ● Linear intake and outlet ● Suitable for equipment with small ventilation resistance
<p>Blowers</p> 	<p>Blower Features</p> <ul style="list-style-type: none"> ● High static pressure ● Right angle intake and outlet ● Suitable for equipment requiring local cooling and with large ventilation resistance.

Selection from external dimensions and max. airflow

● See 3D data of DC fans and blowers in the electronic catalog distributed separately or at the web2-CAD site (<http://www.web2cad.co.jp/>).

AC/DC	External Dimensions mm (inch)	Series	Page in Catalog	Max. airflow (m ³ /min)															
				1	2	3	4	5	6	7	8	9	10	11	12	13	14		
DC	□40 x 13 (□1.6" x 0.5")	EUDC	G-16	■															
DC	□40 x 28 (□1.6" x 1.1")	G0428C (G series)	G-31	■	■														
DC	□60 x 25 (□2.4" x 1.0")	TUDC	G-17	■	■														
DC	□60 x 38 (□2.4" x 1.5")	G0638B (G series)	G-32	■	■	■													
DC	□80 x 25 (□3.2" x 1.0")	PUDC	G-18	■	■	■													
DC	□80 x 38 (□2.4" x 1.5")	G0838C	G-33	■	■	■	■												
DC	□92 x 25 (□3.6" x 1.0")	KUDC	G-19	■	■	■	■												
DC	□92 x 25 (□3.6" x 1.0")	D0925C (Gentle Typhoon)	G-20	■	■	■	■	■											
DC	□92 x 32 (□3.6" x 1.3")	KLDC	G-21	■	■	■	■	■											
DC	□92 x 38 (□3.6" x 1.5")	G0938B	G-34	■	■	■	■	■	■										
DC	□120x 25 (□4.7" x 1.0")	CUDC	G-22	■	■	■	■	■	■										
DC	□119 x 25 (□4.7" x 1.0")	D1225C (Gentle Typhoon)	G-23	■	■	■	■	■	■										
DC	□120 x 38 (□4.7" x 1.5")	CNDC	G-24	■	■	■	■	■	■	■									
DC	□120 x 38 (□4.7" x 1.5")	D1238T	G-25	■	■	■	■	■	■	■									
DC	□120 x 38 (□4.7" x 1.5")	G1238B	G-34/G-26	■	■	■	■	■	■	■	■								
DC	□119 x 38 (□4.7" x 1.5")	D1238B (G series)	G-35	■	■	■	■	■	■	■	■								
DC	□127 x 38 (□5.0" x 1.5")	D1338B	G-27	■	■	■	■	■	■	■	■								
DC	□127 x 38 (□5.0" x 1.5")	D1338S	G-28	■	■	■	■	■	■	■	■								
DC	φ 172[x150]x51(6.8[6.0]x2.0")	D1751M/D1751S	G-29/G-30	■	■	■	■	■	■	■	■	■	■	■	■	■	■	■	■
DC	φ 172[x150]x51(6.8[6.0]x2.0")	G1751M	G-36	■	■	■	■	■	■	■	■	■	■	■	■	■	■	■	■
AC	□80 x 25 (□3.2" x 1.0")	VE	G-55	■	■														
AC	□92 x 25 (□3.6" x 1.0")	WE	G-56	■	■														
AC	□92x 38 (□3.6" x 1.5")	KA	G-57	■	■	■													
AC	□120 x 25 (□4.7" x 1.0")	SCUA/CU	G-53/G-58	■	■	■													
AC	□120 x 38 (□4.7" x 1.5")	SCNA/CN	G-54/G-59	■	■	■	■												
AC	φ 172[x150]x51(6.8[6.0]x2.0")	MA/PA	G-60/G-61	■	■	■	■	■	■	■	■	■	■	■	■	■	■	■	■
AC	□180 x 90 (□7.1" x 3.5")	PL	G-62	■	■	■	■	■	■	■	■	■	■	■	■	■	■	■	■

■ Model code for DC fans and blowers (15-digit code)

■ Manufacturing lot No.

D 12 38 B 24 B 5 A Z - 00

9 A 25

- Customized code
 - 00: Standard type
 - A01: Standard type (Model change product)
 - 04: 4P Terminal type
- Rotation sensor
 - S: Lock detection type
 - Q: Speed detection type
 - R: Speed detection type (Output reversion type)
 - P: Pulse output type
 - Z: No sensor (Standard type)
- Special code
 - A: Standard type
 - C: Higher moisture resistance
 - Y,Z: Variable speed
- Speed 1.2 ~ 9.A.B.C: Low ↔ High
- Bearings B: Ball bearing
- Voltage: 05: DC5 V 12: DC12 V 24: DC24 V 48: DC48 V
- Frame type
 - B: Square metal venturi
 - C: Square resin venturi with ribs
 - D: Square resin venturi without ribs
 - E: Black painted type B
 - S: Round metal venturi
 - T: Round plastic venturi
- Thickness (as mm)
- Frame dimensions (as cm)
- Category
 - D: DC fan
 - E: DC blower
 - G: High static pressure DC fan

- Date manufactured
- Month manufactured: A ~ L = January ~ December
- Year manufactured (Last digit of year)
- U: Black painted type S
- M: Round side cut venturi
- P: Black painted type M
- H: Spiral casing (1)
- L: Spiral casing (2)
- K: Reverse rotation spiral casing

Selection from external dimensions and max. airflow

AC/DC	External Dimensions mm (inch)	Series	Page in Catalog	Max. Airflow (m ³ /min)																
				0.2	0.4	0.6	0.8	1.0	1.2	1.4	1.6	1.8	2.0	18	19					
DC	□48×25 (□1.9"×1.0")	E0525H/E0525K	G-37																	
DC	□51×53×15 (□2.0"×2.1"×0.6")	E0515H	G-38																	
DC	□70×76×20 (□2.8"×3.0"×0.8")	E0720L	G-39																	
DC	□72×75×20 (□2.8"×3.0"×0.8")	E0720L	G-40																	
DC	□76×25 (□3.0"×1.0")	SMBD	G-41																	
DC	□76×30 (□3.0"×1.2")	MBDC	G-42																	
DC	□87×18 (□3.4"×0.7")	E0818K	G-43																	
DC	□94×30 (□3.7"×1.2")	SFBD	G-44																	
DC	□97×95×25 (□3.8"×3.7"×1.0")	E1027H	G-45																	
DC	□97×95×33 (□3.8"×3.7"×1.3")	E1033H/Y	G-46																	
DC	□119×117×32 (□4.7"×4.6"×1.3")	E1232L	G-47																	
DC	□126×127×31 (□5.0"×5.0"×1.2")	E1331K	G-48																	
DC	□150×152×40 (□5.9"×6.0"×1.6")	E1540H	G-49																	
DC	φ220×71 (φ8.7"×2.8")	E2271Z	G-50																	
AC	□125×126×41 (□4.9"×5.0"×1.6")	CB	G-63																	

Model code for DC axial fans and blowers (Previous Axial Flow Fans and Blowers)

CNDC 12 B 7 R S

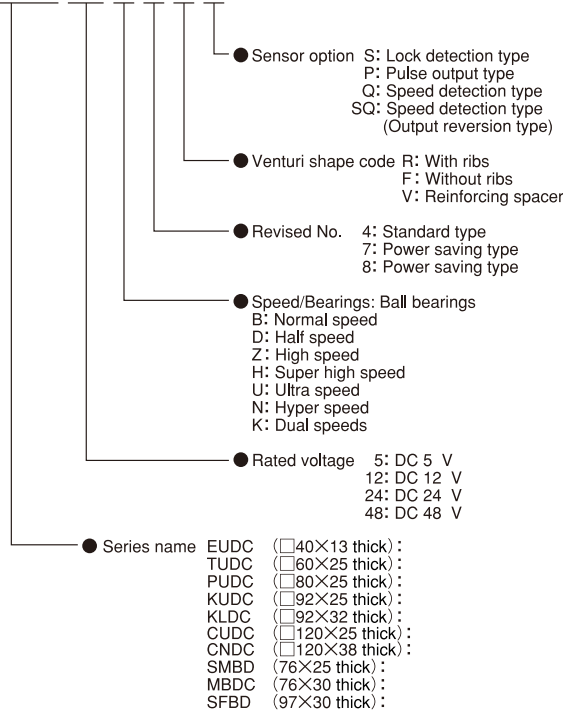

Model code for AC axial fans and blowers (Previous Axial Flow Fans and Blowers)

CN J 55 B 5 1 □

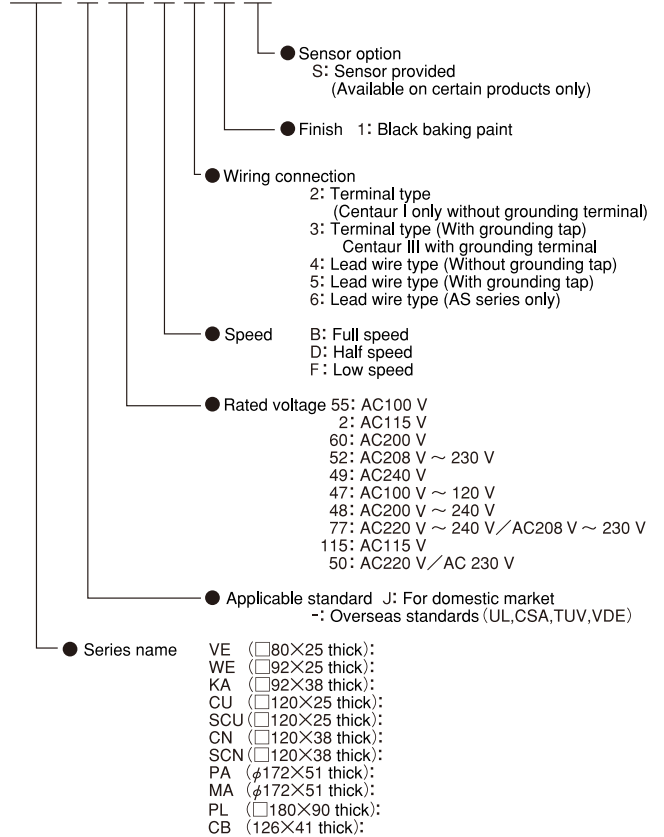

Characteristics of Fans and Blowers

Airflow - static pressure characteristics (PQ characteristics)

1. Pressure loss (Ventilating resistance)

A force to obstruct the flow of air (pressure loss) is generated when air is channeled onto equipment, due to the parts layout and the shape of the air stream inside the equipment. This phenomenon is called ventilating resistance (also called "system impedance" and "channel resistance"). Air meets only modest resistance when it moves straight ahead within a wide space. (Fig. 1) When air passes through a narrow space or when the direction of an airflow changes, the ventilating resistance increases. (Fig. 2) The ventilating resistance increases further unless an outlet path (or a circulation path) is provided because an airflow cannot be created.

Ventilating resistance is small

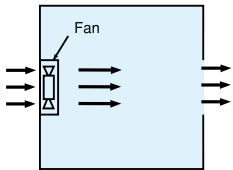

Fig. 1

Ventilating resistance is large

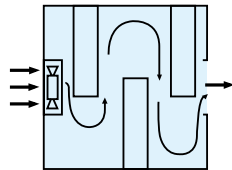

Fig. 2

2. Differences in PQ characteristics of fans and blowers

As illustrated in Fig. 3, the PQ characteristics exhibit characteristic trends when a motor of equivalent power is used. The fan has a large airflow and its static pressure is 1/2 to 1/5 that of the blower. The blower has large static pressure and its airflow is 1/2 to 1/5 that of the fan.

In the absence of a ventilating resistance (0 Pa), the max. airflow (QFmax) flows, under circumstances where there are no objects located around the fan (This free air condition is the x-axis). However, this condition does not exist as long as a fan is assembled in equipment. The state showing considerable ventilating resistance and a lack of airflow corresponds to the y-axis in Fig. 3 and the airflow is zero because the air does not move. In this condition, there are obstacles in front and to the rear of a fan that prevent airflow or that shut off the circulation path of the air. This operating condition cannot be considered when a fan is used for cooling or ventilation purposes. (Continuing operation in this condition may damage the fan.)

The actual operating conditions vary between the two aforementioned extremes. Fig. 3 plots four ventilating resistances (plotted via quadratic curves). Units of equipment containing either a fan or a blower have varying ventilating resistances, of which these four curves show typical examples. The airflow flowing into the equipment is at the intersection between the ventilating resistance curve and the PQ characteristics of the fan or the blower. The curve of Ventilating Resistance 1, which has the smallest inclination, is assumed to be the ventilating resistance of ordinary equipment. At this ventilating resistance, there are no large obstacles in front and to the rear of the fan and an adequate circulation path is provided. The fan can be operated most efficiently at this Ventilating Resistance 1, where about 80 % of the maximum fan airflow is possible. (Airflow of QF2 with a fan and of QB2 with a blower respectively)

Of the four curves, the airflow of any equipment that has Ventilating Resistance Curve 4, with the largest inclination, will be a fraction of the max. airflow, even though a high performance fan or blower is installed. In this condition, the airflow will be QB1 with a blower and QF1 with a fan, the airflow of the blower being larger.

The airflows of Ventilating Resistance Curves 2 and 3, in between, will also be airflows at the intersection with the respective PQ characteristics. NIDEC SERVO supplies fans dedicated to a high static pressure region, with fan motors optimally designed for intermediate ventilating resistances. As Fig. 4 explains, quieter and energy saving operations are more feasible in the high static pressure region compared with ordinary axial fans. (See page G-36)

By minimizing the ventilating resistance of the equipment and by using power-saving fans and blowers, both cost and noise reduction can be achieved, resulting in an ideal cooling solution. (Actual example: Ventilating resistance was reduced and quiet operation achieved by changing the thickness of a 92 square fan from 32 to 25 with equipment having densely mounted parts (Ventilating Resistance 3 in Fig. 4).

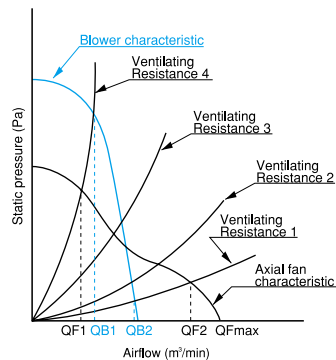

Fig. 3

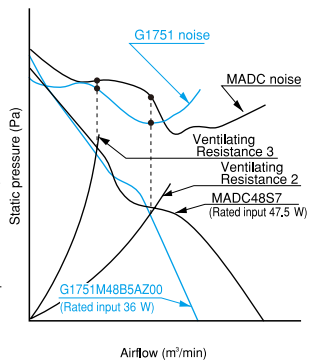

Fig. 4

3. Method for calculating the required fan airflow

The method to calculate the required airflows (ventilation rates) is described for the cooling of equipment which generates heat.

The airflow (ventilation rate) necessary for internal equipment cooling is calculated as follows: (Note: the entire heat is exhausted by ventilation airflow and heat from radiation or conduction is not taken into consideration)

$$Q = \frac{W}{\rho \times C \times \Delta T}$$

Q : Required airflow [m³/s]
 W : Heat generation rate [W]
 ρ : Specific weight of air [kg / m³]
 C : Specific heat of air [J / kg°C]
 ΔT : temperature rise of air [°C]

(ρ and C are values at 25 °C. Use the value 1100 instead of 1200 at 50 °C)

Example: When wishing to limit the air temperature rise inside equipment that generates 100 W of heat, the following calculation formula is used:

$$Q = \frac{100}{1200 \times 10} = 8.3 \times 10^{-3} \text{ m}^3/\text{s} = 0.50 \text{ m}^3/\text{min}$$

An airflow of 0.50 m³ / min or more is required. This calculation formula for the required airflows (ventilation rate) can be translated into a graph as shown in Fig. 5.

Air temperature rise and required airflow

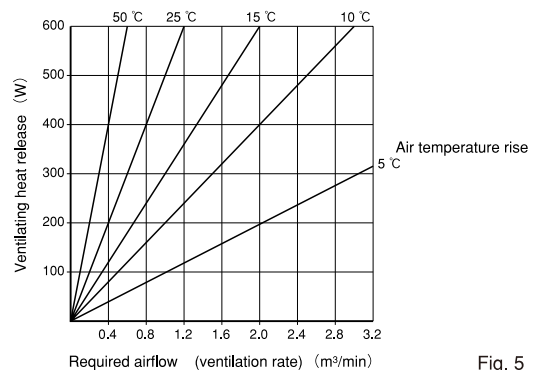

Fig. 5

4. Fan and blower selection

The required airflow and ventilating resistance of equipment must be determined when selecting a fan or a blower. However, accurate determination of a ventilating resistance is difficult. In general you can select a fan's max. airflow by multiplying the required airflow by 1.3 to 1.5. (The following figure [Fig. 6] shows the case of an air channel with an area approximately equal to that of the fan.)

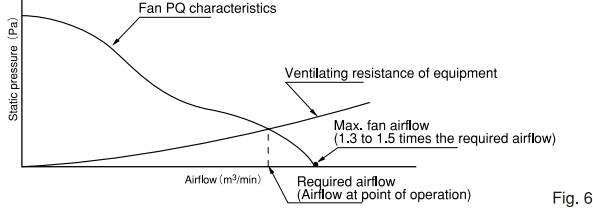

Fig. 6

If an adequate air channel is not available due to a high density of mounted parts, a fan with a max. airflow of more than two times the required airflow is sometimes needed. In this case, a special fan for a high static pressure region or a blower is recommended.

The following methods are used to accurately determine the ventilating resistance of equipment:

- 1) Send the equipment to a fan manufacturer and ask them to measure the ventilating resistance.
- 2) If 3D data of the equipment is available, ask the fan manufacturer to calculate the resistance.
- 3) Install a fan or a blower, whose relationship between the PQ characteristics and speed is already known, within the equipment and determine the ventilating resistance by measuring the speed.

5. PQ characteristics via the parallel or serial operations of axial fans Parallel operation of 2 fans

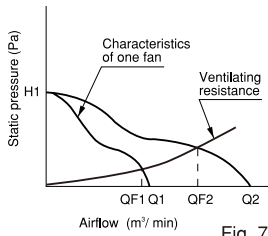

Fig. 7

When two fans are operated in parallel, only the max. airflow will double. Intersections QF1 and QF2 with ventilating resistance curves of the equipment will be the airflow actually flowing. This mode is advantageous when wishing to increase the airflow of equipment with only modest ventilation resistance.

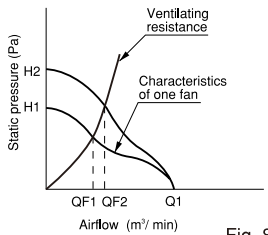

Fig. 8

Serial operation of 2 fans
When two fans are operated in series (stacked), only the maximum static pressure will increase by 1.5 times. Intersections QF1 and QF2 with ventilating resistance curves of the equipment will be the airflow actually flowing.

This mode is advantageous when wishing to increase the airflow of equipment with high ventilation resistance.

(Note: A fan specially designed for a high static pressure region will be further advantageous for equipment that has high ventilating resistance. [See Fig. 9.]

Serial operation of 2 fans with stationary blades for a high static pressure region

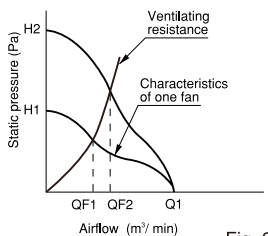

Fig. 9

When two fans are run in series (stacked), only the maximum static pressure will increase by 1.8 to 2 times. NIDEC SERVO special fans for high static pressure regions have stationary blades and achieve a lower reduction in static pressure during serial operation. The intersections QF1 and QF2 with ventilating resistance curves of the equipment will be the airflows actually flowing.

6. Voltage imposed to fan and blower and PQ characteristics

DC powered fans and blowers have the following relationship between the imposed voltage and the PQ characteristics. The following information will be useful when fine tuning performance or when using a fan or a blower for experimental purposes:

(Note: Only test operation is allowed to be used outside of the specified voltage range. Note that this information is not applicable to AC powered fans, nor to certain DC fans. [Example: SADC fans] Please check the product information pages.)

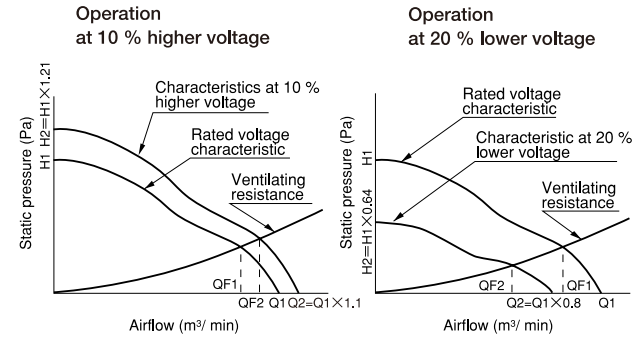

Fig. 10

Fig. 11

The speeds of fans and blowers vary in proportion of the voltage. Varying the voltage $\pm 10\%$ will also cause the speed to vary by $\pm 10\%$. The speed affects the static pressure and airflow as follows. The static pressure varies based on the square of the speed and the airflow varies in proportion of the speed. Varying voltage $\pm 10\%$ will cause the maximum static pressure to vary -19 to $+21\%$, and the max. airflow to vary $\pm 10\%$. (See Fig. 10.)

An understanding of these relationships will allow free adjustment of the PQ characteristics during fan and blower operation.

7. Performance degradation of PQ characteristics when options are installed

Options such as a fan guard and filter are sometimes installed for safety. These options, however, increase the ventilation resistance and noise. A fan guard has slight ventilation resistance and degrades the PQ characteristics only negligibly. However, when tightly fitted onto a fan, the noise level increases by about $+1$ to $+5$ dB. In particularly, options should be installed more than 10 mm away from the fan to minimize the increase in noise.

Using a $120\text{ mm} \times 38\text{ mm}$ AC fan (CN55B3) as an example, fluctuations of the PQ characteristics when options are installed are plotted in Figs. 12 and 13.

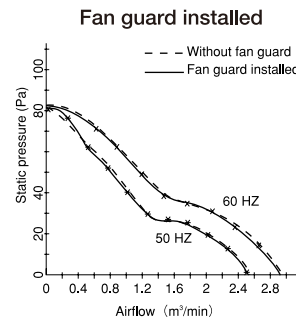

Fig. 12

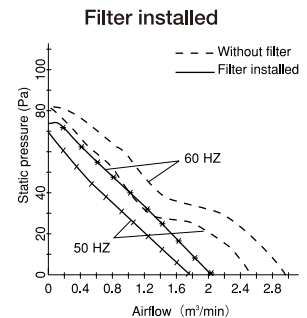

Fig. 13

8. Unit conversion tables of PQ characteristics

At present, the PQ characteristics are expressed in Japan by Pa (static pressure) and m³/min (airflow). Use the following conversion tables for conversion between CFM, which is used in some countries, and between the units previously used in Japan.

Table 1 Static pressure conversion table

Pa=N/m ²	mmHzO	inHzO	kgf/cm ²	atm	bar	lbf/in ²
1	1.02×10 ⁻¹	4.02×10 ⁻³	1.02×10 ⁻⁵	9.87×10 ⁻⁶	1.00×10 ⁻²	1.45×10 ⁻⁴
9.81	1	3.94×10 ⁻²	1.00×10 ⁻⁴	9.68×10 ⁻⁵	9.80×10 ⁻⁵	1.42×10 ⁻³
2.49×10 ²	25.4×10 ¹	1	2.54×10 ⁻³	2.46×10 ⁻³	2.49×10 ⁻³	3.61×10 ⁻²
9.81×10 ⁴	1.00×10 ⁴	3.94×10 ²	1	9.68×10 ⁻¹	9.81×10 ⁻¹	14.2×10 ¹
1.01×10 ⁵	1.03×10 ⁴	4.07×10 ²	1.03	1	1.01	14.7×10 ¹
1.00×10 ⁵	1.02×10 ⁴	4.02×10 ²	1.02	9.87×10 ⁻¹	1	14.5×10 ¹
6.9×10 ⁵	7.03×10 ²	2.77×10 ¹	7.03×10 ⁻²	6.81×10 ⁻²	6.90×10 ⁻²	1

Table 2 Airflow conversion table

m ³ /s	m ³ /min	l/S	l/min	m ³ /h	ft ³ /S	CFM
1	6.00×10 ¹	1.00×10 ³	6.00×10 ⁴	3.60×10 ³	3.53×10 ¹	2.12×10 ³
1.67×10 ⁻²	1	1.67×10 ¹	1.00×10 ³	6.00×10 ¹	5.89×10 ⁻¹	3.53×10 ¹
1.00×10 ⁻³	6.00×10 ⁻²	1	6.00×10 ¹	3.60	3.53×10 ⁻²	2.12
1.67×10 ⁻⁴	1.00×10 ⁻³	1.67×10 ⁻²	1	6.00×10 ⁻²	5.89×10 ⁻³	3.53×10 ⁻²
2.78×10 ⁻⁴	1.67×10 ⁻²	2.78×10 ⁻¹	1.67×10 ¹	1	9.81×10 ⁻³	5.88×10 ⁻¹
2.83×10 ⁻²	1.7	2.83×10 ¹	1.70×10 ³	1.02×10 ²	1	6.00×10 ¹
4.72×10 ⁻⁴	2.83×10 ⁻²	4.72×10 ⁻¹	2.83×10 ¹	1.70	1.67×10 ⁻²	1

9. Measurement method of PQ characteristics

The aerodynamic characteristic measuring apparatus is illustrated in Fig. 14. This apparatus conforms to the ANSI/AMCA Standard 210-85, as well as JIS B 8330 (Testing methods for turbo-fans).

It is very difficult to measure PQ performance with high accuracy and the various measuring equipment used by fan manufacturers feature a wide range of accuracy. For this reason, simultaneous acquisition of comparable data obtained by the same measuring apparatus is recommended when verification of strict variation in performance is desired. (NIDEC SERVO also measures the comparative data of fans manufactured by other fan manufacturers as a customer service - please make use of this.)

Aerodynamic test apparatus (Double chamber type)

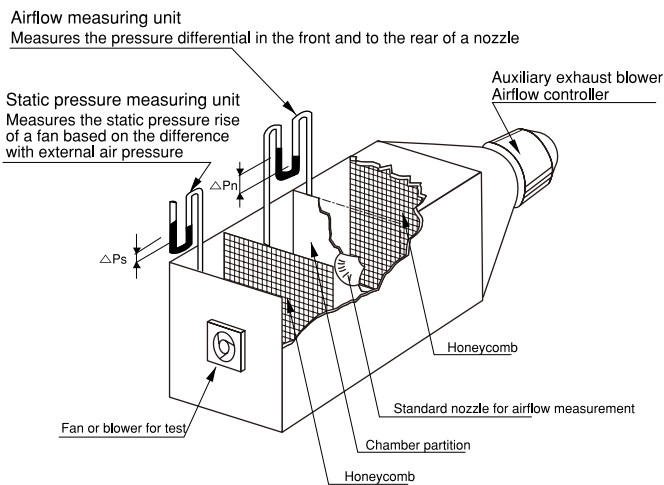

Fig. 14

■ Noise

1. Types of noise

Noise is generated by the combination of various conditions. Measures to eliminate or reduce noise can be taken more easily by analyzing the details of the noise.

When reducing the noise of your equipment, take into account the following factors that contribute toward noise generation:

Aerodynamic noise	Noise of rotation	Propeller sound · · · Sound emitted by the revolutions of blades Periodic flow fluctuations of flow · · · · · Interference and air separation with stationary blades, strut and venturi.
	Eddy flow sound	Turbulence in inflow flow, random eddy discharge from the eddy flow boundary layer on blade surfaces and air separation.
Mechanical noise	Vibration sound	Mechanical motor vibration sound · · · Imbalanced revolutions, resonance and vibration transfer sound. Electromagnetic sound of motor · · · · · Vibration sound by phase change (switching).
Cavity noise		Air column resonance and other sounds

2. Noise of fan

The noise of the fan itself (catalog noise) is measured in a small anechoic room, in which background noise is adequately low, in a free-air state with no objects surrounding the fan. The aerodynamic noise (blade sound) and motor sound are the principal noise sources.

3. Noise after installation in equipment

After installing the fan in your equipment the noise level sometimes increases drastically (up 8 dB to 15 dB) compared with the noise emitted by the fan itself. This is caused by the resonance of the fan vibration within the equipment, an obstacle in front of the intake (the fan guard may also become an obstacle), an increase in load noise due to ventilating resistance, the use of a fan with excessively large power, an insufficient circulation path, and other causes.

Noise can be reduced significantly by reducing the factors that increase noise. (In the best case scenario, only the noise level of the fan itself is generated)

NIDEC SERVO provides a service to analyze customers' equipment noise. Please contact NIDEC SERVO with your requirements.

4. Noise measurement

Noise is measured in accordance with the test method specified in JIS C 9603 Ventilating fans in Range A measurement, placed in a position 1 m in front of the intake side of fans and blowers. (Background noise 15 dB (A))

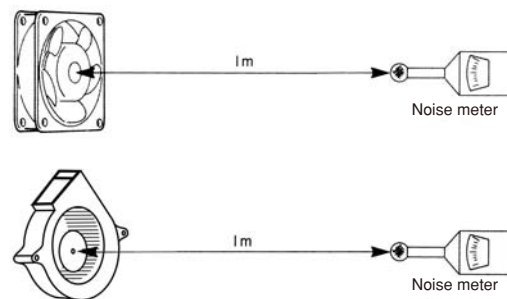

Fig. 15

5. Noise calculation

Noise is a sound pressure value measured in a position where the energy of a sound source arrives. It is called a sound pressure level (SPL) and is expressed in dB.

If the sound energy increases 10 times, the sound level increases 10 dB and 60 dB represents sound pressure energy that is 1000 times that of 30 dB and 10000 times that of 20 dB.

The total noise of several fans is calculated as follows:

$$\text{Total noise (L)} = 10 \log (10^{L_1/10} + 10^{L_2/10} + \dots + 10^{L_n/10})$$

(Noise values of individual values are L1, L2 Ln)

Example: If four fans individually emit noise of 30 dB, 35 dB, 40 dB and 45 dB,

the total noise of the four fans will be:

$$L = 10 \log (10^{30/10} + 10^{35/10} + 10^{40/10} + 10^{45/10}) = 46.6 \text{ dB}$$

If all three fans emit 40dB, their total noise will be:

$$L = 10 \log (10^{40/10} + 10^{40/10} + 10^{40/10}) = 40 + 10 \log 3 = 44.8 \text{ dB}$$

The noise can be calculated from the following graph in Fig. 16 if the noise difference between two fans is 13 dB or less:

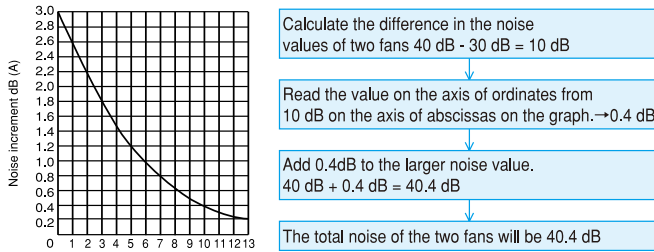

Fig. 16

6. Speed and noise value

A fan's noise value is the total of the aerodynamic and motor noise. Most noise is aerodynamic in nature, except in products with a low speed.

The speed and noise value vary in proportion to the sixth power and the noise value increases when the speed increases. (Some people say that they vary in proportion to the fifth power.) Increasing the speed will double the max. airflow and quadruple the maximum static pressure. Noise increases 18.1 dB (+15 dB at the fifth power).

$$dB2 = dB1 + 60 \log (N2/N1)$$

dB1: Noise value when the speed is N1

dB2: Noise value when the speed is N2

Speed	2000 min ⁻¹ (Standard)	2200 min ⁻¹	2600 min ⁻¹	3000 min ⁻¹	4000 min ⁻¹
Noise value	0	+2.5 dB	+6.8 dB	+10.6 dB	+18.1 dB

7. Propeller diameter and noise level

The fan noise is strongly linked to the propeller size. Comparing the noise of fans with equivalent speed, the noise theoretically varies to the seventh power of the propeller diameter as follows:

In reality, the propeller shape is not symmetric and calculations cannot be performed as explained in the theory. However, the noise value with equivalent airflow rate will be as shown in the following table, indicating that a larger fan will reduce noise. (Value calculated based on the theory that the airflow varies to the third power of the propeller diameter)

$$dB2 = dB1 + 70 \log (D2/D1)$$

dB1: Noise value when the speed is D1

dB2: Noise value when the speed is D2

Propeller diameter	55 mm	75 mm	86 mm	114 mm (Standard)	121 mm	142 mm
Noise value with equivalent speed	-22.2 dB	-12.7 dB	-8.6 dB	0	+1.8 dB	+6.7 dB
Noise value with equivalent airflow	+34.8 dB	+20.0 dB	+13.5 dB	0	-2.8 dB	-10.5 dB

8. Object distance and noise value

The noise value (SPL) decreases as the sound source becomes distant while the fan noise value varies in proportion to the square of the distance and can be expressed by the following formula: (When the reflection sound to nearby walls is ignored)

$$dB2 = dB1 - 20 \log (L2/L1)$$

dB1: Noise value when the distance from the sound source is L1

dB2: Noise value when the distance from the sound source is L2

Distance from sound	50 cm	1 m (Standard)	150 cm
source Noise value	+6 dB	0	-3.5 dB

9. Ventilating resistance and noise value

Fan manufacturers note the noise values in their catalogs assuming a free air condition (ventilating resistance 0). When fans are physically assembled in equipment, the ventilating resistance cannot be zero and the noise values listed in catalogs are for reference purposes only. A method used to estimate sound values when fans are assembled in equipment is described below.

A noise value at each point of the PQ characteristics is called "load noise" and fans and blowers have their own characteristics. (See Figs. 17 and 18.)

The load noise is the noise of the fan itself at the point of operation. Fan characteristics include a "neck" (dip) in the plotted curves. This dip is caused by turbulence in the airflow on the propeller surfaces and noise increases steeply between this part and a low airflow region.

The fan has an area where noise becomes lowest (region of higher airflow than the neck). The circulation path should be designed such as to reduce ventilating resistance. However, if the ventilating resistance cannot be reduced with any equipment after trying various ideas, the study of fans for a high static pressure region is recommended. These are fans that have been developed and designed to emit low noise in a high static pressure region compared with ordinary fans. (See Fig. 4 on pages G-6 and G-31 to G-36.)

As plotted in Fig. 18, the load noise of blowers generally varies only slightly, while trends in load noise differ from one product to another of the blower manufacturers. Even if the catalog values are the same, noise invariably varies at the same operating point.

The blowers manufactured by NIDEC SERVO are designed to emit the lowest noise at customers' operating points so that the customers can base catalog load noise values reliably as actual blower noise.

Load noise of fan (CNDC24B7)

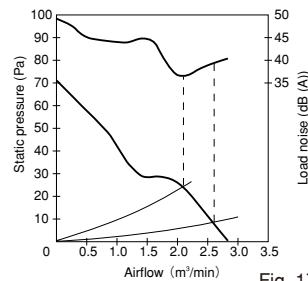

Fig. 17

Load noise of blower (E1331K and SCBD [former model])

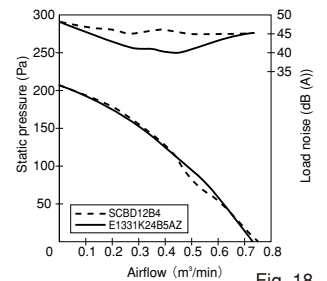

Fig. 18

10. Fan guards increase noise

When mounted directly onto a fan, a fan guard increases noise by about +1 to +5 dB. Install a fan guard more than 10 mm from equipment to reduce the increase in noise.

11. Equipment resonance with fan

The fan contains a motor that causes mechanical vibration and electrical vibration, which sometimes causes equipment containing a fan to resonate. This problem can be solved by combining the following three methods:

- 1) Cut off the vibration transfer route to equipment by providing a rubber vibration isolator or other cushioning.
- 2) Change the natural frequency of equipment by changing the board thickness or by other means.
- 3) Change to a low-vibration fan (customized product), in which case consult NIDEC SERVO for more information.

12. Quiet operation by Silent Fan

The rotating sound (blade sound) is the principal factor generating the noise of ordinary square axial fans.

The frequency characteristic of these fans peaks at the number of blades x speed and the related high frequency component. This is mainly caused by periodical fluctuations of blade lift due to non-uniform airflow (turbulence), caused by an object on the upstream side of the fan and attributed to the shape of the fan venturi.

The NIDEC SERVO Silent Fans, part of the range of axial fans with a unique venturi shape, are renowned for their particular quietness. To prevent non-uniform airflow on the upstream side of the fan, the venturi mounting flange has a single flange on the outlet side only, as illustrated in Fig. 19. The intake flow velocity and direction of the fan are made constant through analysis of the air intake flow to prevent separation of flow from the peripheral parts of the venturi, thereby achieving exceptional quietness. Thanks to the design preventing flow disturbance on the intake side when a fan is mounted, a premium silence effect unrivalled by conventional square fans is achieved.

Comparison of noise generating sources

● **Silent Fan**

Intake air flows in a fixed direction and at a constant flow velocity along the arc on the edge, hardly producing any noisy eddy turbulence.

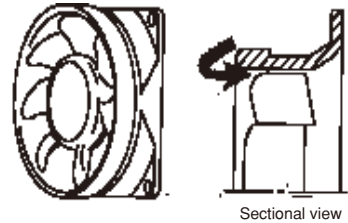

Fig. 19

● **Square Venturi Fan**

The airflow on the intake side is not constant. Differences in flow velocity and direction cause shear flow and trigger periodic lift fluctuations, leading to noise generation.

The air separation phenomenon occurs in the edge part, which is the thinnest part of the square venturi and round intake side, generating many eddy turbulences and increasing propeller resistance, thereby causing noise.

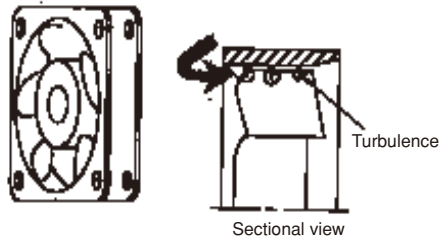

Fig. 20

13. The low-noise benefits you can get from our Gentle Typhoon. It has the perfect noise performance !

We at NIDEC Servo enhanced our Silent Fan Technology to bring you a brand new series called Gentle Typhoon in 2008. Designers can expect drastic noise reductions when building products with this fan.

Our Gentle Typhoon works to dampen noise in your products based on the combination of the propeller blades, which brings to mind spinning vortices of air and the square venturi which deters the occurrence of turbulence. Not only is the acoustic level improved, but so is overall noise quality.

The square shape offers compatibility conventional fans currently used by designers. Replace your current use fan for the Gentle Typhoon and experience a tranquil quieting of your next device. (20 and G-23)

Life of fans and blowers

The life of fans is solely dependent on bearings. The bearing load P in relation to the basic rated load C is $P \ll C$, (meaning P is a great deal smaller than C). Therefore we can say that grease life determines the fan life.

Grease life is significantly affected by ambient temperature. The fans of NIDEC SERVO feature a special design that minimizes grease temperature rises as illustrated below.

● AC fan

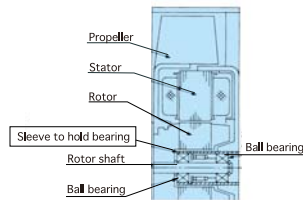

Fig. 21

● DC fan

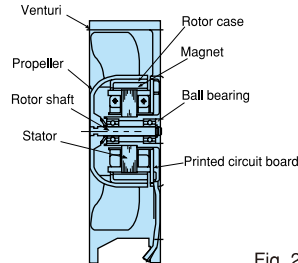

Fig. 22

■ Long-life structure

The fan motor contains two parts which generate heat, namely, the stator and rotor.

The AC fan holds a bearing in a dedicated sleeve to help retard the transfer of heat generated by the rotor, and limit the temperature rises of the bearing.

The DC fan has an external rotor structure and the temperature of the bearing is significantly affected by stator temperature. When the speed rank rises, the motor temperature also rises, thereby increasing the heat transfer to the bearing. NIDEC SERVO fans feature a high-efficiency circuit and low motor losses to keep the bearing temperature below the preset temperature, thereby ensuring a long life.

The bearing temperature differs depending on the structure, materials and other factors and life varies to some extent. However, the life expectancy as illustrated in Fig. 23 is the basic data.

NIDEC SERVO accepts inquiries and orders for semi-customized products (long life products) featuring a reduction in bearing temperature increase. Please contact NIDEC SERVO for further information.

The life expectancy curve that is common to AC and DC fans is plotted in Fig. 23. (The curve represents the life expectancy based on a survival rate of 90 % and is not the guaranteed life. NIDEC SERVO will provide the MTTF (mean time to failure) data upon request.)

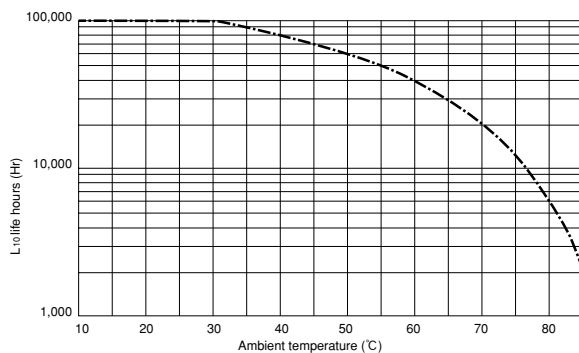

Fig. 23 Life expectancy curve (Survival rate 90 %)

(Note: This life expectancy curve has been prepared based on the results of life tests conducted at a rated voltage in a free air condition in an environmental test room with a negligible amount of dust. When using the fans in your application please take into consideration the actual operating conditions and safety factors. Some of the products contained in the catalogs do not meet the foregoing life expectancy data. [Products which do not meet the standard life are listed on the product information pages.]

(Definition of life: End of life is defined when the speed or noise of a product deteriorates by 20 %)

Applicable standards

NIDEC SERVO fans and blowers have been accepted in certification tests for Japanese and overseas safety standards for use in various applications. (Please inquire to NIDEC SERVO for standards that are not included in the following.)

◆ Electrical Appliance and Material Safety Law (Japan)

The AC fans that fall under the scope of the Electrical Appliance and Material Safety Law are manufactured in compliance with its technical standard. AC fans are classified as fans and blowers in one of 480 electrical appliance item categories other than specified electrical appliances. The marking of the (PS)E mark is a legal obligation. See page G-53 and subsequent pages for NIDEC SERVO products with the (PS)E mark. Power plug cords are classified as specified electrical appliances and the marking of the <PS>E mark is a legal obligation. (See page G-66.)

◆ Certification test by the UL Standard

NIDEC SERVO fans and blowers have been accepted in certification tests under the fan and blower safety test standard UL-507,73 of UNDERWRITERS LABORATORIES INC., the electrical appliance safety inspection organization of the United States. Products that are accepted in certification tests are marked with the mark on their nameplates and model names are registered, to attest that they are certified products.

The registration No. of NIDEC SERVO is

E 48889: Fans and blowers

E 78112: Plugs and cords

(Category Nos. W1007, W1008)

Non-regular factory audits by UL are conducted in connection with the production of certified products and safety verification is performed by ensuring the materials used, electrical characteristics and other items pass strict factory test inspections.

◆ Certification test by the CSA Standard

NIDEC SERVO fans and blowers have been accepted in certification tests, based on general specification requirements and rules to prevent overheating inside motors under fan and blower safety test standard CSA STANDARDS C22.2 Nos. 113 and 0.077 of the CANADIAN STANDARDS ASSOCIATION, the electrical appliance safety inspection organization of Canada. Products that are accepted in certification tests are marked with the mark on their nameplates and model names are registered, to attest that they are certified products under the CSA standards.

The registration No. of NIDEC SERVO is

LR49399: Made in Japan

LR108118: Made in Indonesia

As with the UL standards, safety verification is performed by ensuring non-regular factory audits are performed by CSA.

(Some products are certified by the mark.)

◆ Certification test by TUV

NIDEC SERVO fans and blowers have been accepted in safety certification tests based on the Business-Use Electrical Equipment Standard EN60950 and the VDE Standard No. 0806/08.81 of T RHEINLAND e.V, the industrial electrical appliance safety inspection organization of Germany. Products that are accepted in certification tests are marked with the mark on their nameplates and model names are registered, to attest that they are certified products under the TUV standards.

The registration Nos. of NIDEC SERVO are:

LICENCE No.:R60299, R60300, R60301, R60302, R9451586

:R9750695, R9750455, R9650662, R2-50004410

REPORT No.:E61087, E61088, E61089, E61090

As under the UL and CSA standards, safety verification is performed by clearing non-regular factory audits by TUV.

◆ Certification test by VDE

NIDEC SERVO fans and blowers have been accepted in safety certification tests based on the Fan and Blower Safety Inspection Standard DIN VDE0700 of VERBAND DEUTSCHER ELEKTROTECHNIKER e.V., an electrical appliance safety inspection organization of Germany with the highest authority. Products that are accepted in certification tests are marked with the  mark on their nameplates and model names are registered, to attest that they are certified products under the VDE standards.

The registration No. of NIDEC SERVO is 3019.

As under the UL, CSA and TUV standards, safety verification is performed by clearing non-regular factory audits by VDE.

Common electrical specifications (Operational cautions)**● Insulation class**

The insulation class of AC and DC fans and the blowers of NIDEC SERVO meet the heat resistance performance of Class E (120 °C) under JIS C 4004 (Rotating electrical machines - General), CLASS A (105 °C) under the UL-703 standard, CLASS A (105 °C) under the CSA-C22.2 standard, and DIN IEC950/VDE0806 standard and CLASS E (90 °C) under the VDE0700 standard.

● Dielectric strength

The AC fans and blowers of NIDEC SERVO satisfy 1500 V 50 Hz for one minute or 1800 V 50 Hz for one second. Dielectric strength tests under JIS C 4004 specify a voltage impression of "2 x rated voltage + 1000 V."

The DC fans and blowers of NIDEC SERVO are accepted in withstand voltage tests of 500 V 50 Hz for one minute or 600 V 50 Hz for one second. The interrupting current of 5 mA is set for the dielectric strength testers.

Dielectric strengths are tested between the power terminal of the fan/blower or lead wire conductor (two lead wires tied together) and metal frame (or other metal part) using a dielectric strength tester.

● Insulation resistance

The insulation resistance of the AC and DC fans and blowers of NIDEC SERVO is 10 MΩ or higher at 500 V DC between the power terminal or lead wire conductor and frame. Insulation resistance tests are conducted between the power terminal of the fan/blower or lead wire conductor (two lead wires tied together) and metal frame (or other metal part) using an insulation resistance tester.

● Electrical performance

The values described in the catalog are average values. Please request NIDEC SERVO to send a product drawing or delivery specification for products when wishing to confirm standard values.

● Temperature protection

Two methods are used to protect the temperature of the windings of AC fans and blowers, namely, impedance protection and thermal protection. These two methods are used differently depending on the type of motor used.

Impedance protection method

This method is generally used with shaded pole induction motors. Temperature increase is limited below a preset value by impedance (AC resistance) natural to the motor windings. In particular, the UL standard specifies that motors must not burn out when the rotor is operated for 18 days at normal temperature (24 °C). NIDEC SERVO fans and blowers meet this standard. Those products that are controlled by the Electrical Appliance and Material Safety Law of Japan are designed to limit coil temperature rises to less than 75 K.

The impedance protection method is effective only within the usage range. Note that smoke will be generated and ignition caused if a high voltage is imposed.

Thermal protection method

This method is used with motors of a capacitor phase advancing type or triple-phase induction motors. Embedding a bimetal switch with a contact in the motor winding part, the current is shut off when the preset winding temperature is exceeded, to prevent burning caused by abnormal overheating of the motor.

The windings of DC fans and blowers are protected against abnormal temperature rises by automatic reset, by shutting off the current if it detects a locked state or by current limiting automatic reset. This method involves the energizing circuit being turned off by a lock detection function inside the motor drive circuit when the fan is locked, shutting off (or limiting) the current.

Operation is reactivated automatically after the locking is reset. Note that this protection system does not function properly if used with duty (PWM) control power supply. NIDEC SERVO supplies variable-speed fans whose speed can be variably controlled by a PWM signal. (See pages G-31 to G-36, and G-51.)

Vital Precautions for DC Fans and Blowers

● Reverse connection protection

The DC fans and blowers embed a reverse connection protection circuit. Fans or blowers will not fail, even if connected in reverse within the usage range. (The fans or blowers will not activate, as no current flows to the circuit.)

● Yield strength to electrical noise

Yield strength to static noise: The yield strength between the lines or between a frame and line is 5 kV.

Yield strength to induced noise: Yield strength by an induced noise test apparatus is 2 kV.

Note 1: Malfunction of the sensor alarms will result if the induced noise exceeds 1 kV. Insert a 0.1 μF capacitor between the sensor line and ground as a precaution.

Note 2: Some of the products without a 15-digit product code cannot guarantee these yield strengths. Contact NIDEC SERVO for further information.

● Static electricity control

A static electricity measure is needed if a terminal trailing from the fan motor is touched, otherwise the circuit is prone to damage by static electricity.

● Handling of the alarm output lead wires

Inadvertently using a tester or other apparatus with a sensor lead wire will cause overcurrent to flow to the sensor circuit inside the motor, potentially causing a circuit fault. Pay attention to the permissible current and prevent any overcurrent from flowing. Contact NIDEC SERVO if it becomes necessary to connect an LED or relay directly to a sensor lead wire. (There are products that allow a current larger than the permissible current described on page G-15 depending on conditions.)

● Power supply selection for DC fans and blowers

Select a power source that supplies smooth power (ripples within ±5 %, peak within operating voltage). Significant line noise (including surge voltage) causes circuit faults. Make it a point to check line noise after assembling a fan.

Select a power source remembering that a current 2 to 5 times the rated current flows at startup. (If an inrush current [normally less than 10 μs] poses a problem, measure it and take action accordingly.)

The operating current peaks when the motor load is largest (at maximum static pressure for fans and in free air condition for blowers). When assembled, the current sometimes exceeds the rated current (fans) or smaller (blowers). (See the diagrams below.)

When current is flowing, connect all terminals from the fan motor before turning it on. Imperfect wiring connection or a wiring change while the power is turned on will damage the circuit inside the fan or cause it to deteriorate.

● Power ON and OFF of DC fans and blowers

Always perform ON-OFF control on the + side. ON - OFF control on the ground level causes circuit failure. ON-OFF control directly before a DC fan or a blower (between a fan and power supply) increases the risk of failures due to the counter-electromotive force from the motor coil. In this case, be sure to insert a diode or other device in parallel.

Surge voltage can sometimes be generated with DC fans and blowers due to a wiring condition or other reason, even if the power is turned off. Insert a diode or other device in parallel to the power lead wire when the equipment requires very high reliability.

(Recommended diode: With a capacity to withstand reverse voltage and a starting current 3 times the rated voltage)

● DUTY (PWM) control of DC fans and blowers

The locking protection circuit does not function properly if variable-speed operation is performed through DUTY (PWM [pulse width modulation]) control of the power lead wire using a speed controller sold on the market or other device. The alarm output does not function properly with fans that are installed with sensors. As mentioned earlier, caution should also be exercised with surge voltage that occurs during ON-OFF switching in DUTY control (out of guarantee.) Please note that this operating method increases fan vibration, increasing the likelihood of abnormal sounds due to vibration. Dedicated fans and blowers are recommended for variable-speed operations. (See pages G-31 to G-36 and G-51.)

● Connect multiple DC fans and blowers in parallel

Connect multiple fans and blowers in parallel to the power supply. A serial connection (example: two 12 V products connected serially to a 24 V power supply) will cause the voltage for each product to fluctuate, resulting in a drastic excess of the usage range and circuit failure.

Please direct your questions or inquiries to NIDEC SERVO Sales or to the NIDEC SERVO website.

Example of fan operating current (SCNDM12B4)

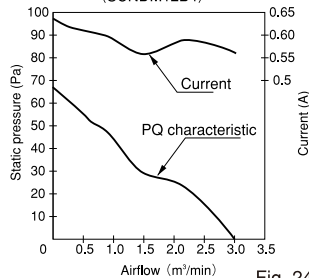

Fig. 24

Example of blower operating current (E1331K)

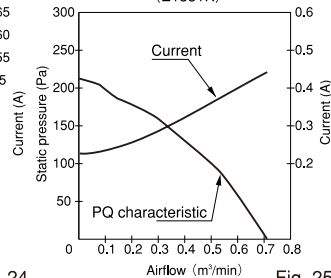

Fig. 25

Operational and handling precautions

Operational precautions

The products of NIDEC SERVO are designed and manufactured to be as versatile as possible. Nevertheless, exercise caution with the following:

1. Operating environment

- 1) Only highly durable flame-retardant resin is used. Nevertheless, avoid the presence of petroleum oil, such as cutting fluid and toxic gas from contact with resin sections of fans and blowers where such oil or gas is frequently used in operation by installing a filter or other apparatus. (If the operating environment cannot be improved, NIDEC SERVO will be glad to conduct a yield strength verification test upon receipt of fluid and other item/s. Consult NIDEC SERVO for more information.)
- 2) Open-type motors are used. The use of a fan or blower in a dusty place will adversely affect the circuit and ball bearings.
- 3) Avoid operating a fan or a blower in relative humidity exceeding 90 %.
- 4) The maximum storage temperature is normally 70 °C. Products with an operating temperature of 70 °C or higher can be operated only up to the specified temperature. Check the operating temperature range on the product information pages.
- 5) Exercise reasonable care with condensation when returning to an environment higher than 0 °C from storage or operating conditions below freezing point. Condensation results in failure and shortens the life.
- 6) The life may shorten considerably if a fan or a blower is installed in equipment that vibrates prominently. NIDEC SERVO products conform to JIS C 0040 (Vibration testing methods for small motors) and withstand a maximum vibration acceleration of 9.1 G maximum (10 Hz to 55 Hz, amplitude 1.5 mm, sweep 1 minute/cycle, two hours each in X, Y and Z directions). However, operation at 5 G or less is recommended.
- 7) AC and DC fans and blowers cannot be operated while the intake side is tightly closed. This will shorten the motor life and result in circuit failure.
- 8) Operation near a high frequency power source may on rare occasions cause inflow of an induced current into the inside of a fan, shortening the life (and increasing noise due to BB galvanic corrosion). If an induced current flows, measures to prevent such inflow are needed.

2. Imposed voltage and frequency

- 1) The permissible range of AC fans and blowers is ±10 % of the rated voltage. Operations outside of the rated frequency result in considerable fluctuations in performance and life. Operations in serial connection (example: two 100 V products connected serially to a 200 V power supply) will increase the imposed voltage beyond the permissible range and should be avoided.
- 2) Use a sufficiently smooth power supply with DC fans and blowers. (Ripples of ±5 % or less, and peak within the usage range) The usage range differs from one product to another. Check it on the product information pages.

3. Installation orientation

There are no installation orientation limitations for products containing ball bearings. Operate fans and blowers in compliance with the operating environment temperature and other conditions. Contact NIDEC SERVO for further information or if clarification is needed.

Handling precautions

The fan motors of NIDEC SERVO contain double side shielded precision ball bearings. Dropping the product could result in abnormal noise (Brinell dent) of ball bearings during operation. Exercise care when handling the products as follows:

1. Product falling: Avoid dropping the product from a height of 5 cm or higher.
2. Falling of crated product: Avoid dropping a crated product from a height of 30 cm or higher.
3. Storage and stacking of crated products: Crated products may be stacked up to seven layers. Take sufficient precautionary measures to prevent

getting them wet.

4. Do not apply a load of 2 kgf or more to the connecting part of the lead wire of a DC fan.

5. Fan installation: Exercise caution as follows when installing a fan on a panel or elsewhere.

- 1) Clamping of both flanges: The permissible tightening torque of M4 screws is 8 kgf · cm with an AC fan that has a metal venturi and up to 10 kgf · cm with a DC fan that has fan ribs. Through screws are not acceptable for the DC flange type. Use reinforcing spacers (for the KUDC and CNDC series) to tighten the double flanges on these products. (See page G-65.)
- 2) Clamping of single flange: The permissible tightening torque of screws when the installation surface is flat is 10 kgf · cm to 14 kgf · cm for both AC and DC fans.
- 3) Avoid contact with a propeller or impeller when mounting the intake side of fans and blowers. Excessive screw tightening will result in contact with a deformed venturi or housing.

Fan operational precautions

- Strive to ensure the channel shape is as smooth as possible to avoid stagnation in the airflow.
- Make the flow velocity larger around the object for which cooling is desired.
- Place the fan on the downstream side when wishing to cool the entire space inside the equipment.
- An upward flow in conjunction with the ascension of heated air is recommended for airflow inside equipment.
- Take actions to mitigate the impacts of fans and for reverse flow in the event of failure where multiple fans are installed.

1. When placing an object on the fan intake side, try to maintain a distance of more than half a blade diameter.

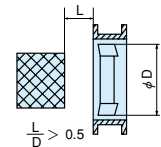

2. The pressure varies on the fan intake and outlet sides. The leakage of air from the outlet side causes noise. Minimize air leakage from the outlet side when installing a fan.

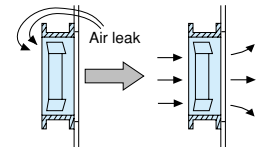

3. Design the channel (circulation path) selecting a good flow direction in terms of both noise and PQ characteristics.

• Ventilating resistance can be expressed by the following formula:

$$P = 0.000243Q^2 \sum_{i=1}^N \frac{1}{A_i^2}$$

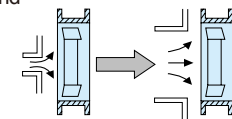

A reduction of A_i (the channel cross sectional area) is critical. Avoid any sharp change in the cross sectional area in the flow direction.

• Avoid any sharp change in flow direction.

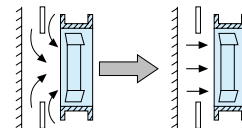

• Avoid placing a printed circuit board and other parts orthogonal to the flow direction.

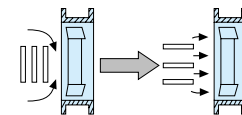

4. Drill fan mounting holes to ensure the smooth flow of air to reduce noise by referring to the recommended dimensions for fan mounting holes on the fan or blower's catalog page.

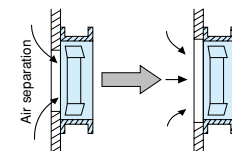

DC axial fans & blowers with sensors

The DC fans and blowers of NIDEK SERVO have a function to send an alarm signal when the fan motor revolutions slow down. Several systems are used to cut off the system power supply by this alarm signal, with three types of sensors available. Select the right type of sensor in accordance with the purpose of use. The lead wire for the sensor is yellow. The output type is an open collector output for all three types.

■ Sensor type

1. Lock detection type (Product code: S)

The output signal indicates an [L] state (transistor is ON) while the propeller is rotating, changing to an [H] state (transistor is OFF) less than five seconds after the propeller stops rotating. The propeller automatically restarts operation within five seconds when the lock is unlocked. ([H] → [L] 5 s). If the pull-up voltage is live, the [H] state (transistor is OFF) will engage in less than five seconds, even when the power is turned off.

- Specification: $V_{CE} = 28\text{ V max}$
(55.2 V max for 48 V products)
 $I_C = 5\text{ mA max}$
($V_{CE(SAT)} = 0.4\text{ V max}$)
- Output waveform

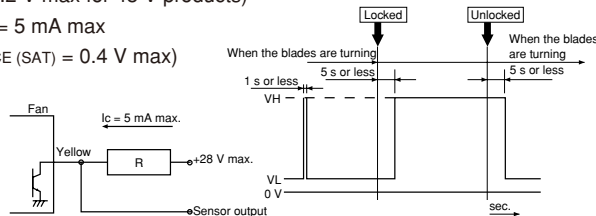

※When the power is turned on, the state sometimes becomes high [H] for several hundred ms.

2. Pulse output type (Product code: P)

A rectangular wave of two pulses will be output for each turn of the propeller while the propeller is rotating, outputting two types of signal depending on the propeller position when the propeller is locked. (See the note below ※)

- Specification: $V_{CE} = 28\text{ V max}$
(55.2 V max for 48 V products)
 $I_C = 5\text{ mA max}$
($V_{CE(SAT)} = 0.4\text{ V max}$)
- Output waveform

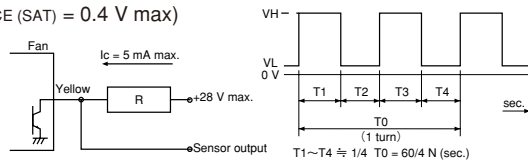

※Output signal waveform when the fan is stopped: The following two types of waveform are output, depending on the blade position when the propeller is stopped:
Pulse outputs of High - constant or restart timing (0.05 Hz to 2 Hz).

3. Speed detection type (Product code: Q)

The output signal indicates the [H] state when the propeller revolutions are slower than the preset speed, changing to the [L] state when the propeller revolutions exceed the reset speed. [Products with a reversed output waveform are also available, suitable for a wired OR connection when several fans are installed. Contact NIDEK SERVO for further information. {Former code: SQ, new code (15 - digit code products): R}]

- Specification: $V_{CE} = 28\text{ V max}$
(55.2 V max for 48 V products)
 $I_C = 5\text{ mA max}$
($V_{CE(SAT)} = 0.4\text{ V max}$)
- Output waveform

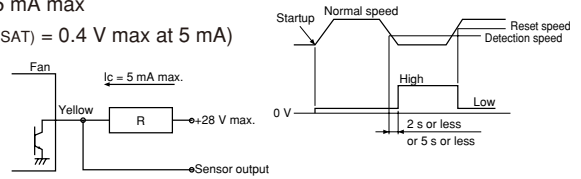

Note: The output waveform for type SQ (R) will be reversed. The speed setting for the alarm output is about half the rated speed. For more detailed information, please request a product delivery specification from NIDEK SERVO.

AC fans with sensors

By equipping the motor with a rotation detection function, the AC fans of NIDEK SERVO have a system to send an alarm signal when the fan motor revolutions slow down and to cut off the system power supply. In 1980, NIDEK SERVO developed a system to output an alarm signal by detecting the lowering of generated voltage by installing a tachometer generator with the cooling fan and this system has since been incorporated in NIDEK SERVO products. The output type of the alarm signal is an open collector output.

Type	Tachometer generator type			
Sensor output operation	Open collector transistor, permissible sync Current: 50 mA max. Permissible imposed voltage: DC 40 V max. Permissible power consumption: 1.5 W max. (at 25 °C)			
Sensor output operation	AC power supply	Speed	Output transistor operation	Output state
	OFF		OPEN	HIGH (Abnormal)
	ON	Below detection speed	OPEN	HIGH (Abnormal)
	ON	Above detection speed	CLOSE	LOW (Normal)
Detection speed RD	1500 ~ 2200 rpm			
Detection delay time TD	2 s or less 17 Type			
Type	Standard speed			
Insulation resistance	10 M Ω or higher by a DC 500 V: Between the sensor lead and venturi			
Dielectric strength	Between the sensor lead and venturi		No anomaly allowed after applying AC 500 V 50 Hz for 1 minute	

■ Sensor specification

■ Operational and handling precautions

Operate fans and blowers at an ambient temperature of between -10 °C and 60 °C and relative humidity of less than 90 %. Latch output is not used so malfunction by electrical noise can be ruled out. However, note that the semiconductor devices in the internal circuitry may be damaged by electrical noise and high voltage. No delay circuit is provided so a trouble signal is output on startup. As when operating and handling the fan, exercise caution to avoid dropping and exposing the blower to shock and vibration.

■ Sensor connection

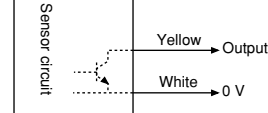

1. LED Display

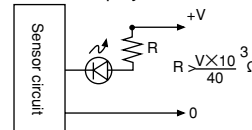

2. Relay operation

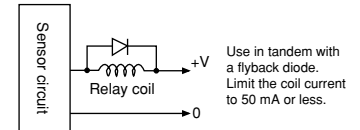

※ A sensor is available with the AS ad PL series only.

DC Axial Fan

EUDC



□ 40 × 13 (□ 1.6" × 0.5")

Max. airflow: 0.23 m³/min
Max. static pressure: 79 Pa
Mass: 26 g

Fan model code

EUDC12B8

EUDC12B8S

EUDC12D8

EUDC12D8S

EUDC12Z8

EUDC12Z8P

EUDC24B8

EUDC24B8S

Standard specification

Max. Airflow m ³ /min	Max. Static Pressure CFM	Max. Static Pressure Pa	Noise inH ₂ O	Noise dB	Speed min ⁻¹	Input W	Voltage Spec. V		Current mA		Model Code	Operating Temp. Range °C
							Rating	Operating Range	Rating	Starting		
0.23	8.1	79	0.32	37	9000	1.5	12	7.2-13.8	130	270	EUDC12Z8	-20 ~ +70
							12	7.2-13.8	75	190		
0.18	6.4	59	0.24	30	7200	0.9	12	14.4-27.6	50	100	EUDC24B8	-20 ~ +80
							12	14.4-27.6	50	100		
0.12	4.2	30	0.12	26	5200	0.5	12	8.4-13.8	40	90	EUDC12D8	

- Figures in the table are average measured values. Please request the product delivery specification when preparing a purchase specification.
- The characteristics are the values at rated voltage (12 V or 24 V), and normal temperature and humidity.
- The life expectancy of EUDC12Z8 at rated voltage and in continuous operation is 30,000 hours at 60 °C. (40,000 hours for other products at 60 °C)

General specification

Materials Used	Venturi: ABS and PBT synthetic resins Propeller: ABS and PBT synthetic resins Bearing: Both side shielded ball bearing
Motor	Brushless DC motor, Protection type: Current shut off by detecting lock state, automatically reset
Common Elec. Spec.	See pages G-11, G-12, G-13.
Standard Carton	400 to a carton of (450 x 380 x 300) mm, mass 12 kg

Standard airflow and static pressure characteristics (At rated voltage)

[By double chamber method]

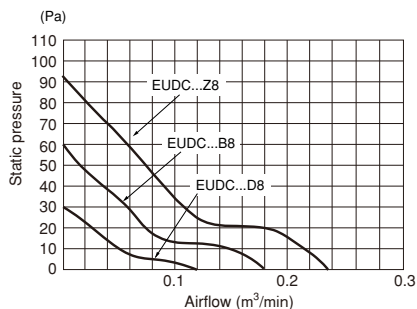

External dimensions in mm (inches)

● Lead wire type

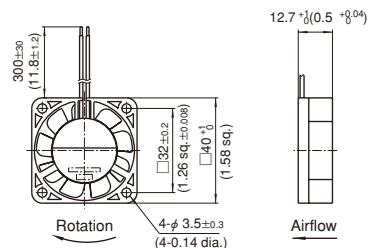

Lead wire spec. AWG24 UL1007 or UL3266
Color (+) Red
(-) Black

Wiring connection diagram

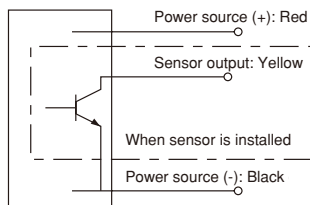

Mounting hole dimensions in mm (inches)
[Recommendation]

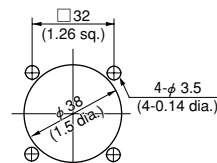

DC axial fan with sensor

Rated Voltage	Model Code		
12 V	EUDC12D8S	EUDC12B8S	EUDC12Z8P
24 V		EUDC24B8S	

- NIDEC SERVO can meet many of your requirements for customization, such as special connectors, other sensors not listed above, variable speed specifications, and other modifications. Please contact NIDEC SERVO during your product planning and development stage.
- The listed products are registered in the following overseas standards files, UL: E48889, CSA: LR49399, TUV: R9451586
- 3D data is also available at our web2-CAD site (www.cadenas.co.jp).

Fans & Blowers

Axial

DC fans

Centrifugal

Silent

AC fans

Centrifugal

Option

DC Axial Fan

TUDC



□ 60 × 25 (□ 2.4" × 1.0")
Max. airflow: 0.87 m³/min
Max. static pressure: 130 Pa
Mass: 75 g

Fan model code

- TUDC12B4
- TUDC12B4F
- TUDC12B4P
- TUDC12B4S
- TUDC12D4
- TUDC12D4F
- TUDC12D4Q
- TUDC12D4S
- TUDC12H4
- TUDC12H4P
- TUDC12H4S
- TUDC12H4SQ
- TUDC12N7
- TUDC12N7F
- TUDC12N7P
- TUDC12N7S
- TUDC12U7
- TUDC12U7P
- TUDC12U7S
- TUDC12Z4
- TUDC12Z4F
- TUDC12Z4FS
- TUDC12Z4P
- TUDC12Z4Q
- TUDC12Z4S
- TUDC24B4
- TUDC24B4F
- TUDC24B4S
- TUDC24D4
- TUDC24D4F
- TUDC24D4S
- TUDC24H4
- TUDC24H4F
- TUDC24H4P
- TUDC24H4S
- TUDC24N7
- TUDC24N7F
- TUDC24N7P
- TUDC24N7S
- TUDC24Z4
- TUDC24Z4F
- TUDC24Z4FS
- TUDC24Z4P
- TUDC24Z4Q
- TUDC24Z4S
- TUDC48B4
- TUDC48B4P
- TUDC48B4S
- TUDC48H4
- TUDC48H4P
- TUDC48Z4
- TUDC48Z4FS
- TUDC48Z4P

Standard specification

Max. Airflow m ³ /min	Max. Static Pressure CFM	Max. Static Pressure Pa	Noise inH ₂ O	Noise dB	Speed min ⁻¹	Input W	Voltage Spec. V		Current mA		Model Code		Operating Temp. Range °C	
							Rating	Operating Range	Rating	Starting	Open Flange	Ribbed Flange		
0.87	31	130	0.52	46	6800	4.2	12	7.2-13.8	350	1430	TUDC12N7F	TUDC12N7	-20 ~ +60	
							24	12-27.6	170	700	TUDC24N7F	TUDC24N7		
0.74	26	100	0.40	39	5700	2.5	12	6-13.8	210	790		TUDC12U7		-20 ~ +70
							12	7.2-13.8	220	710		TUDC12H4		
0.65	23	75	0.30	37	5000	2.6	24	12-27.6	110	360	TUDC24H4F	TUDC24H4		
							2.5	48	24-55.2	50		TUDC48H4		
0.55	19	59	0.24	32	4300	1.8	12	7.2-13.8	140	550	TUDC12Z4F	TUDC12Z4		
							24	12-27.6	80	270	TUDC24Z4F	TUDC24Z4		
0.47	17	39	0.16	27	3650	1.4	12	7.2-13.8	130	380	TUDC12B4F	TUDC12B4		
							24	12-27.6	70	190	TUDC24B4F	TUDC24B4		
0.35	12	24	0.10	20	2750	0.9	48	24-55.2	40			TUDC48B4		
							12	8.4-13.8	80	210	TUDC12D4F	TUDC12D4		
							24	14.4-27.6	40	110	TUDC24D4F	TUDC24D4		

- Figures in the table are average measured values. Please request the product delivery specification when preparing a purchase specification.
- The characteristics are the values at rated voltage (12 V, 24 V or 48 V), and normal temperature and humidity.

General specification

Materials Used	Venturi: ABS and PBT synthetic resins Propeller: ABS and PBT synthetic resins Bearing: Both side shielded ball bearing
Motor	Brushless DC motor, Protection type: Current shut off by detecting lock state, automatically reset
Common Elec. Spec.	See pages G-11, G-12, G-13.
Standard Carton	100 to a carton of (450 x 380 x 160) mm, mass 9 kg

● Venturi shape

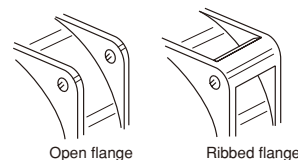

Specify no suffix symbol in your ordering information when the venturi is mounted with screws. Suffix 'F' for an open flange venturi.

Standard airflow and static pressure characteristics (At rated voltage)

[By double chamber method]

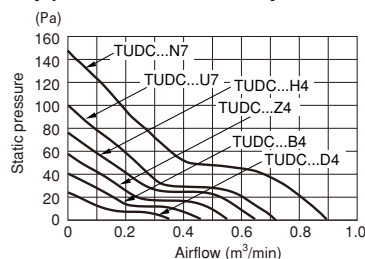

External dimensions in mm (inches)

● Lead wire type

Lead wire spec. AWG24 UL1007 or UL3266
Color (+) Red
(-) Black (TUDC□D4: Blue)

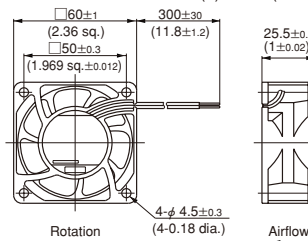

Wiring connection diagram

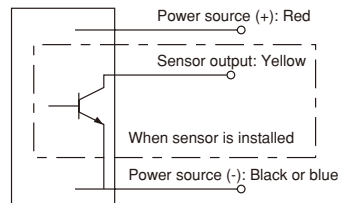

Mounting hole dimensions in mm (inches)
[Recommendation]

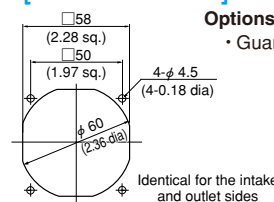

Options (sold separately)

- Guard: F60UL guard
- P60P guard

DC axial fan with sensor

Rated Vol.	Model Code					
12 V	TUDC12D4S	TUDC12B4S	TUDC12Z4S	TUDC12H4S	TUDC12U7S	TUDC12N7S
	TUDC12D4Q		TUDC12Z4FS	TUDC12H4P		
		TUDC12B4P	TUDC12Z4P	TUDC12H4SQ		
24 V	TUDC24D4S	TUDC24B4S	TUDC24Z4S	TUDC24H4S	TUDC12U7P	TUDC12N7P
			TUDC24Z4SQ			TUDC24N7S
			TUDC24Z4FS			TUDC24N7P
48 V		TUDC48B4S	TUDC48Z4S	TUDC48H4S		
		TUDC48B4P	TUDC48Z4Q	TUDC48H4P		
			TUDC48Z4P			

- NIDEC SERVO can meet many of your requirements for customization, such as special connectors, other sensors not listed above, variable speed specifications, and other modifications. Please contact NIDEC SERVO during your product planning and development stage.
- The listed products are registered in the following overseas standards files, UL: E48889, CSA: LR49399, TUV: R9451586
- Customizing to the sleeve bearing specification also accepted depending on the intended purchase quantity. Contact NIDEC SERVO for further information.
- 3D data is also available at our web2-CAD site (www.cadenas.co.jp).

DC Axial Fan

PUDC



□ 80 × 25 (□ 3.2" × 1.0")
Max. airflow: 1.58 m³/min
Max. static pressure: 100 Pa
Mass: 85 g

Fan model code

- PUDC12B4
- PUDC12B4P
- PUDC12B4R
- PUDC12B4RS
- PUDC12B4S
- PUDC12D4
- PUDC12D4R
- PUDC12D4RS
- PUDC12D4S
- PUDC12H4
- PUDC12H4P
- PUDC12H4R
- PUDC12H4RS
- PUDC12H4S
- PUDC12U7
- PUDC12U7P
- PUDC12U7R
- PUDC12U7RP
- PUDC12U7RS
- PUDC12U7S
- PUDC12Z4
- PUDC12Z4P
- PUDC12Z4Q
- PUDC12Z4R
- PUDC12Z4RP
- PUDC12Z4RS
- PUDC12Z4S
- PUDC24B4
- PUDC24B4R
- PUDC24B4RQ
- PUDC24B4RS
- PUDC24B4S
- PUDC24D4
- PUDC24D4Q
- PUDC24D4R
- PUDC24D4RS
- PUDC24D4S
- PUDC24H4
- PUDC24H4R
- PUDC24H4RS
- PUDC24H4S
- PUDC24U7
- PUDC24U7R
- PUDC24U7RS
- PUDC24Z4
- PUDC24Z4P
- PUDC24Z4R
- PUDC24Z4RQ
- PUDC24Z4RS
- PUDC24Z4S
- PUDC48B4
- PUDC48B4P
- PUDC48H4
- PUDC48H4P
- PUDC48Z4
- PUDC48Z4P
- PUDC48Z4S

Standard specification

Max. Airflow		Max. Static Pressure		Noise	Speed	Input	Voltage Spec. V		Current mA		Model Code		Operating Temp. Range °C	
m ³ /min	CFM	Pa	inH ₂ O	dB	min ⁻¹	W	Rating	Operating Range	Rating	Starting	Open Flange	Ribbed Flange		
1.58	56	100	0.40	47	4560	4	12	7.2-13.8	340	1080	PUDC12U7	PUDC12U7R	-20 ~ +60	
							4.3	24	12-27.6	180	510	PUDC24U7		PUDC24U7R
1.32	47	74	0.30	40	3900	3.8	12	7.2-13.8	320	730	PUDC12H4	PUDC12H4R		-20 ~ +70
							24	12-27.6	160	340	PUDC24H4	PUDC24H4R		
						3.2	48	24-55.2	70		PUDC48H4			
1.2	42	59	0.24	35	3500	2.4	12	7.2-13.8	160	520	PUDC12Z4	PUDC12Z4R		-20 ~ +70
							24	12-27.6	100	200	PUDC24Z4	PUDC24Z4R		
						2.6	48	24-55.2	60		PUDC48Z4			
0.94	33	38	0.15	30	2800	1.5	12	7.2-13.8	140	320	PUDC12B4	PUDC12B4R	-20 ~ +70	
							24	12-27.6	70	180	PUDC24B4	PUDC24B4R		
0.73	26	25	0.10	23	2150	1	12	8.4-13.8	80	180	PUDC12D4	PUDC12D4R	-20 ~ +70	
							24	14.4-27.6	40		PUDC24D4	PUDC24D4R		

● Figures in the table are average measured values. Please request the product delivery specification when preparing a purchase specification.
● The characteristics are the values at rated voltage (12 V, 24 V or 48 V), and normal temperature and humidity.

General specification

Materials Used	Venturi: ABS and PBT synthetic resins Propeller: ABS and PBT synthetic resins Bearing: Both side shielded ball bearing
Motor	Brushless DC motor, Protection type: Current shut off by detecting lock state, automatically reset
Common Elec. Spec.	See pages G-11, G-12, G-13.
Standard Carton	120 to a carton of (450 x 380 x 300) mm, mass 10 kg

● Venturi shape

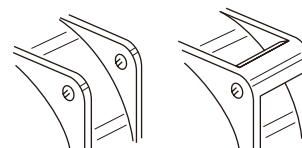

Open flange Ribbed flange

Use ribbed venturi with a reinforced corner when the venturi is mounted with screws. (The spacer is indicated in the model code by the letter 'R'.)

Standard airflow and static pressure characteristics (At rated voltage)

[By double chamber method]

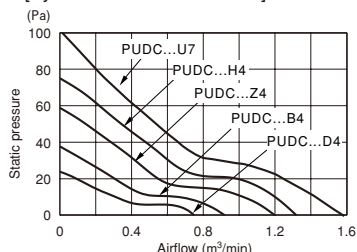

External dimensions in mm (inches)

● Lead wire type

Lead wire spec. AWG24 UL1007 or UL3266
Color (+) Red
(-) Black (PUDC□D4: Blue)

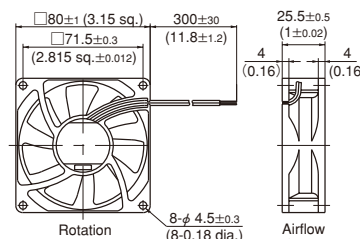

Wiring connection diagram

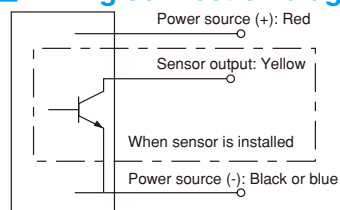

Mounting hole dimensions in mm (inches) [Recommendation]

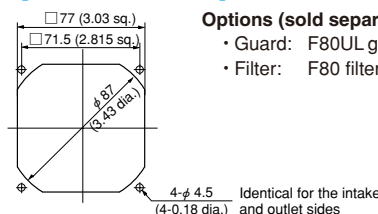

Options (sold separately)

- Guard: F80UL guard
- Filter: F80 filter

DC axial fan with sensor

Rated Vol.	Model Code				
12 V	PUDC12D4S	PUDC12B4S	PUDC12Z4S	PUDC12H4S	PUDC12U7S
	PUDC12D4RS	PUDC12B4RS	PUDC12Z4RS	PUDC12H4RS	PUDC12U7RS
24 V	PUDC24D4S	PUDC24B4S	PUDC24Z4Q	PUDC24H4S	PUDC24U7RS
	PUDC24D4RS	PUDC24B4RS	PUDC24Z4RS	PUDC24H4RS	
48 V		PUDC48B4P	PUDC48Z4S	PUDC48H4P	
			PUDC48Z4P		

- NIDEC SERVO can meet many of your requirements for customization, such as special connectors, other sensors not listed above, variable speed specifications, and other modifications. Please contact NIDEC SERVO during your product planning and development stage.
- The listed products are registered in the following overseas standards files, UL: E48889, CSA: LR49399, TUV: R9451586
- Customized fans with sleeve bearings are also available depending on the intended purchase quantity. Contact NIDEC SERVO for further information.
- 3D data is also available at our web2-CAD site (www.cadenas.co.jp).

DC Axial Fan
KUDC



□92×25 (□3.6"×1.0")
Max. airflow: 1.8 m³/min
Max. static pressure: 70 Pa
Mass: 100 g

Fan model code

- KUDC12B4
- KUDC12B4P
- KUDC12B4V
- KUDC12B4VS
- KUDC12D4
- KUDC12D4V
- KUDC12H7
- KUDC12H7S
- KUDC12H7V
- KUDC12U7
- KUDC12U7P
- KUDC12U7S
- KUDC12U7V
- KUDC12Z7
- KUDC12Z7P
- KUDC12Z7S
- KUDC12Z7V
- KUDC12Z7VP
- KUDC12Z7VS
- KUDC24B4
- KUDC24B4S
- KUDC24B4V
- KUDC24D4
- KUDC24D4S
- KUDC24D4V
- KUDC24H7
- KUDC24H7S
- KUDC24H7V
- KUDC24U7
- KUDC24U7V
- KUDC24U7VS
- KUDC24Z7
- KUDC24Z7P
- KUDC24Z7S
- KUDC24Z7V
- KUDC24Z7VS
- KUDC48B4
- KUDC48B4P
- KUDC48B4VS
- KUDC48Z7
- KUDC48Z7P

Standard specification

Max. Airflow m ³ /min	Max. Static Pressure CFM	Pa	inH ₂ O	Noise dB	Speed min ⁻¹	Input		Voltage Spec. V		Current mA		Model Code		Operating Temp. Range °C
						W	Rating	Rating	Operating Range	Rating	Starting	Open Flange	With Spacer	
1.8	64	70	0.28	41.5	3450	4.2	12	7.2-13.8	350	880	KUDC12U7	KUDC12U7V	-20 ~ +60	
						4.8	24	12-27.6	200	460	KUDC24U7	KUDC24U7V		
1.66	59	60	0.24	39	3200	3.2	12	7.2-13.8	270	690	KUDC12H7	KUDC12H7V	-20 ~ +70	
						3.6	24	12-27.6	150	350	KUDC24H7	KUDC24H7V		
1.55	55	52	0.21	37	2950	3.0	12	7.2-13.8	250	550	KUDC12Z7	KUDC12Z7V	-20 ~ +70	
						3.3	24	12-27.6	140	320	KUDC24Z7	KUDC24Z7V		
1.4	49	43	0.17	34	2750	12	7.2-13.8	230	480	KUDC12B4	KUDC12B4V	-20 ~ +70		
						48	24-55.2	60	130	KUDC48B4	KUDC24B4V			
1	35	24	0.10	26	1950	1.4	12	8.4-13.8	110	240	KUDC12D4	KUDC12D4V	-20 ~ +70	
						1.3	24	14.4-27.6	60	110	KUDC24D4	KUDC24D4V		

- Figures in the table are average measured values. Please request the product delivery specification when preparing a purchase specification.
- The characteristics are the values at rated voltage (12 V, 24 V, or 48 V), and normal temperature and humidity.
- The life expectancy of KUDC-U speed products at rated voltage and in continuous operation is 30,000 hours at 60 °C. (40,000 hours for other products)

General specification

Materials Used	Venturi: ABS and PBT synthetic resins Propeller: ABS and PBT synthetic resins Bearing: Both side shielded ball bearing
Motor	Brushless DC motor, Protection type: Current shut off by detecting lock state, automatically reset
Common Elec. Spec.	See pages G-11, G-12, G-13.
Standard Carton	70 to a carton of (450 x 380 x 300) mm, mass 7 kg

● Venturi shape

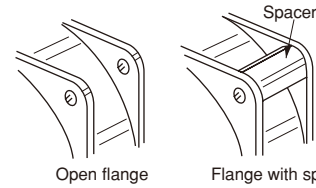

Use the reinforced product with spacer when the venturi is mounted with screws. (The spacer is indicated in the model code by the letter 'V'.)

Standard airflow and static pressure characteristics (At rated voltage)

[By double chamber method]

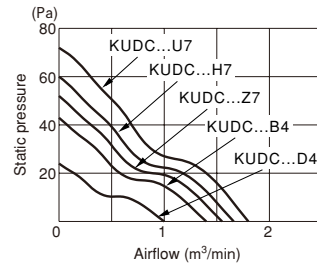

External dimensions in mm (inches)

- Lead wire type Lead wire spec. AWG24 UL1007 or UL3266
Color (+) Red
(-) Black (KUDC□D4: Blue)

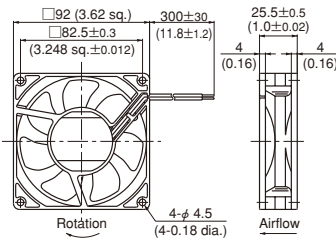

Wiring connection diagram

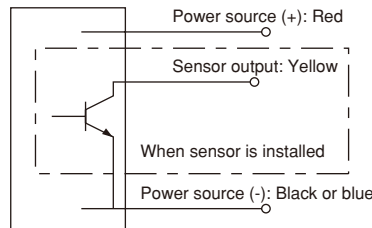

Mounting hole dimensions in mm (inches)
[Recommendation]

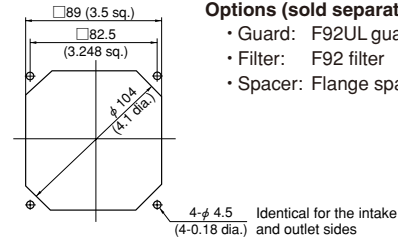

Options (sold separately)

- Guard: F92UL guard
- Filter: F92 filter
- Spacer: Flange spacer PUDC

DC axial fan with sensor

Rated Vol.	Model Code				
12 V		KUDC12B4VS KUDC12B4P	KUDC12Z7S KUDC12Z7VS KUDC12Z7P KUDC12Z7VP	KUDC12H7S	KUDC12U7S KUDC12U7P
	24 V	KUDC24D4S	KUDC24B4S KUDC24Z7S KUDC24Z7VS KUDC24Z7P	KUDC24H7S	KUDC24U7VS
48 V		KUDC48B4S KUDC48B4VS KUDC48B4P	KUDC48Z7P		

- NIDEC SERVO can meet many of your requirements for customization, such as special connectors, other sensors not listed above, variable speed specifications, and other modifications. Please contact NIDEC SERVO during your product planning and development stage.
- The listed products are registered in the following overseas standards files, UL: E48889, CSA: LR49399, TUV: R9451586
- 3D data is also available at our web2-CAD site (www.cadenas.co.jp).

GentleTyphoon™
D0925C



□ 90 × 25

Max. airflow: 2.0m³/min
Max. static pressure: 67Pa
Mass: 100 g

Fan model code

D0925C12B4AS-00

D0925C12B4AZ-00

D0925C12B6AS-00

D0925C12B6AZ-00

D0925C12B8AS-00

D0925C12B8AZ-00

D0925C12B8ZP-00

D0925C24B4AS-00

D0925C24B4AZ-00

D0925C24B6AS-00

D0925C24B6AZ-00

D0925C24B7AS-00

D0925C24B7AZ-00

D0925C24B8ZP-00

Features

- Wider low-noise operating range (50% increase)
- Significant vibration reduction using two methods.
- Energy efficiency (30% less input power than previous models)
- New design improves quality of sound.
- Sensor (lock, pulse) can be installed
- Variable speed (PWM, voltage, resistance) available

Standard specification

Max. Airflow m³/min	Max. Static Pressure CFM	Max. Static Pressure Pa	Max. Static Pressure inH ₂ O	Noise dB	Speed r/min	Voltage Spec. V		Current mA		Model Code	Operating Temp. Range °C
						Rating	Operating Range	Rating	Starting		
2.0	71	67	0.27	40*	4450	12	10.2-13.2	330	850	D0925C12B8AZ-00	-20 ~ +60
1.84	65	55	0.22	38*	4000	24	12.0-26.4	140	430	D0925C24B7AZ-00	-20 ~ +65
1.66	59	48	0.19	35*	3750	12	10.2-13.2	200	650	D0925C12B6AZ-00	-20 ~ +70
				36*		24	12.0-26.4	110	360	D0925C24B6AZ-00	
1.5	53	40	0.16	32*	3400	12	10.2-13.2	150	530	D0925C12B4AZ-00	
				34*		24	12.0-26.4	90	280	D0925C24B4AZ-00	

* (as shown in the noise graph below).

- Figures in the table are average measured values. Please request the product delivery specification when preparing a purchase specification.
- The characteristics are the values at rated voltage (12 V or 24 V), and normal temperature and humidity.
- the only venturi shape available for these products is ribbed flange.
- This fan is specially designed for long life. At rated voltage and in continuous operation the expected life is 60,000 hours at 60°C, (100,000 hours at 40°C), (7.8 speed model: 55,000 hours at 60°C)

General specification

Materials Used	Venturi: SPS synthetic resins Propeller: SPS synthetic resins Bearing: Both side shielded ball bearing
Motor	Brushless DC motor, Protection type: Current shut off by detecting lock state, automatically reset
Common Elec. Spec.	See pages G-11, G-12, G-13.
Standard Carton	70 to a carton of (450 x 380 x 300) mm, mass 7 kg

Standard airflow and static pressure characteristics [At rated voltage]

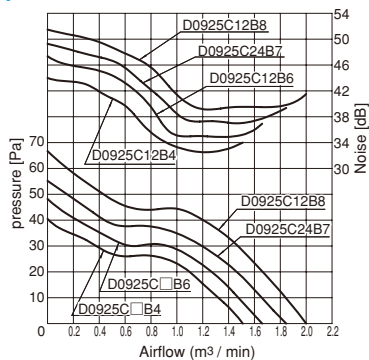

External dimensions in mm

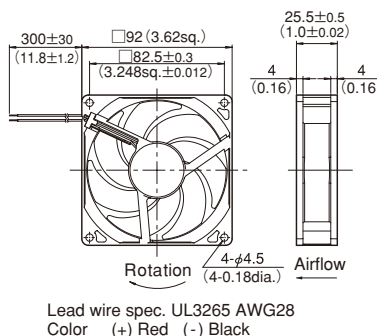

Wiring connection diagram

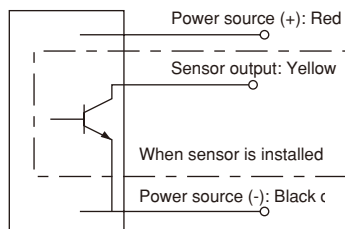

Mounting Hole Dimensions

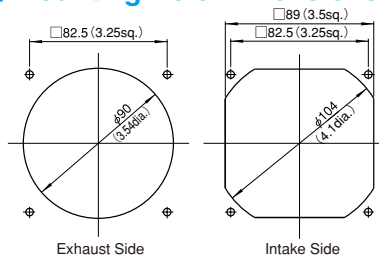

Options (sold separately)

- Guard: F92UL guard
- Filter: F92 filter

DC axial fan with sensor

Rated Voltage	Model Code			
12 V	D0925C12B4AS-00	D0925C12B6AS-00		D0925C12B8AS-00 D0925C12B8ZP-00
24 V	D0925C24B4AS-00	D0925C24B6AS-00	D0925C24B7AS-00	D0925C24B8ZP-00

- PWM (pulse width modulation) allowing for variable speed control is available in some models (reference the G-51 spec).
- NIDEC SERVO can meet many of your requirements for customization, such as special connectors, other sensors not listed above, variable speed specifications, and other modifications. Please contact NIDEC SERVO during your product planning and development stage.
- The listed products are registered in the following overseas standards files, UL/cUL:4889, TUV:R50004410:

DC Axial Fan
KLDC



□92×32 (□3.6"×1.3")
Max. airflow: 2.1 m³/min
Max. static pressure: 140 Pa
Mass: 145 g

Fan model code

KLDC12B4

KLDC12B4F

KLDC12B4S

KLDC12U7

KLDC12Z7

KLDC12Z7FP

KLDC12Z7FS

KLDC12Z7P

KLDC12Z7S

KLDC24B4

KLDC24B4F

KLDC24B4S

KLDC24H7

KLDC24H7F

KLDC24U7

KLDC24Z7

KLDC24Z7F

KLDC24Z7S

Standard specification

Max. Airflow		Max. Static Pressure		Noise dB	Speed min ⁻¹	Input W	Voltage Spec. V		Current mA		Model Code		Operating Temp. Range °C
m ³ /min	CFM	Pa	inH ₂ O				Rating	Operating Range	Rating	Starting	Open Flange	Ribbed Flange	
2.1	74	140	0.56	48	4600	5.7	12	6-13.8	470	1700		KLDC12U7	-20 ~ +60
						6.2	24	12-27.6	260	870		KLDC24U7	
1.9	67	115	0.46	45	4150	4.6	24	12-27.6	190	690	KLDC24H7F	KLDC24H7	-20 ~ +70
1.7	60	86	0.35	43	3800	4	12	7.2-13.8	340	960		KLDC12Z7	
						3.6	24	12-27.6	150	480	KLDC24Z7F	KLDC24Z7	
1.5	53	65	0.26	39	3200	12	12	7.2-13.8	280	570	KLDC12B4F	KLDC12B4	-20 ~ +70
						24	12	12-27.6	140		KLDC24B4F	KLDC24B4	

- Figures in the table are average measured values. Please request the product delivery specification when preparing a purchase specification.
- The characteristics are the values at rated voltage (12 V or 24 V), and normal temperature and humidity.

General specification

Materials Used	Venturi: ABS and PBT synthetic resins Propeller: ABS and PBT synthetic resins Bearing: Both side shielded ball bearing
Motor	Brushless DC motor, Protection type: Current shut off by detecting lock state, automatically reset
Common Elec. Spec.	See pages G-11, G-12, G-13.
Standard Carton	60 to a carton of (450 x 380 x 220) mm, mass 9 kg

● Venturi shape

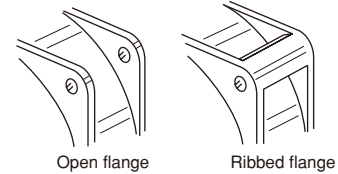

Specify no suffix symbol in your ordering information when the venturi is mounted with screws. Suffix 'F' for an open flange venturi.

Standard airflow and static pressure characteristics [At rated voltage]

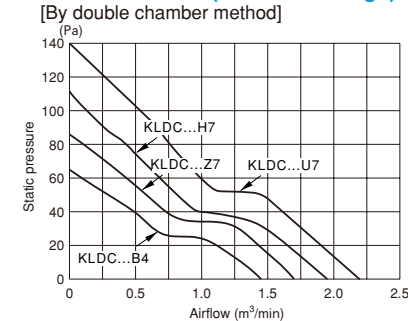

External dimensions in mm (inches)

- Lead wire type: Lead wire spec. AWG24 UL1007 or UL3266
Color (+) Red, (-) Black

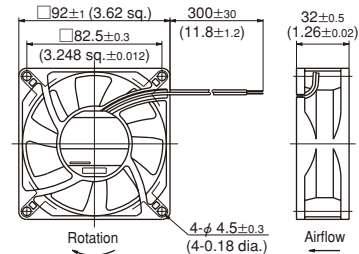

Wiring connection diagram

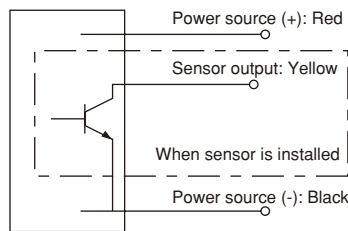

Mounting hole dimensions in mm (inches)
[Recommendation]

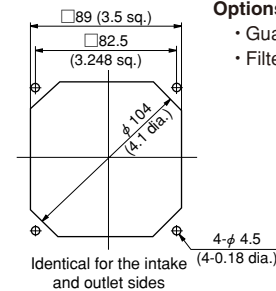

Options (sold separately)

- Guard: F92UL guard
- Filter: F92 filter

DC axial fan with sensor

Rated Voltage	Model Code	
12 V	KLDC12B4S	KLDC12Z7S
		KLDC12Z7FS
		KLDC12Z7P
		KLDC12Z7FP
24 V	KLDC24B4S	KLDC24Z7S

- NIDEC SERVO can meet many of your requirements for customization, such as special connectors, other sensors not listed above, variable speed specifications, and other modifications. Please contact NIDEC SERVO during your product planning and development stage.
- The listed products are registered in the following overseas standards files, UL: E48889, CSA: LR49399, TUV: R9451586
- 3D data is also available at our web2-CAD site (www.cadenas.com.jp).

DC Axial Fan

CUDC



□ 120 × 25 (□ 4.7" × 1.0")
Max. airflow: 3.25 m³/min
Max. static pressure: 125 Pa
Mass: 180 g

- Fan model code
- CUDC12B4Q
 - CUDC12B4QS
 - CUDC12B7
 - CUDC12B7P
 - CUDC12B7R
 - CUDC12B7RS
 - CUDC12B7S
 - CUDC12D4
 - CUDC12D4P
 - CUDC12D4Q
 - CUDC12D4R
 - CUDC12D4RQ
 - CUDC12D4RS
 - CUDC12D4S
 - CUDC12H7
 - CUDC12H7P
 - CUDC12H7S
 - CUDC24B7
 - CUDC24B7P
 - CUDC24B7Q
 - CUDC24B7R
 - CUDC24B7RS
 - CUDC24B7S
 - CUDC24B7SQ
 - CUDC24D4
 - CUDC24D4Q
 - CUDC24D4R
 - CUDC24D4RQ
 - CUDC24D4RS
 - CUDC24D4S
 - CUDC24D4SQ
 - CUDC24H7
 - CUDC24H7P
 - CUDC24H7S
 - CUDC48H7

Standard specification

Max. Airflow m ³ /min	Max. Static Pressure CFM	Max. Static Pressure Pa	Max. Static Pressure inH ₂ O	Noise dB	Speed min ⁻¹	Input W	Voltage Spec. V		Current mA		Model Code		Operating Temp. Range °C
							Rating	Operating Range	Rating	Starting	Open Flange	Ribbed Flange	
3.25	115	125	0.50	50	3700	6.5	12	8.4-13.8	540	2120	CUDC12H7		-20 ~ +70
							24	19.2-27.6	270	1180	CUDC24H7		
							6.7	40.8-55.2	140	450	CUDC48H7		
2.4	85	60	0.24	42	2650	3.4	12	6-13.8	280	740	CUDC12B7	CUDC12B7R	
						3.8	24	12-27.6	160	390	CUDC24B7	CUDC24B7R	
1.7	60	36	0.14	34	1950	2	12	8.4-13.8	160	380	CUDC12D4	CUDC12D4R	
							24	14.4-27.6	90		CUDC24D4	CUDC24D4R	

- Figures in the table are average measured values. Please request the product delivery specification when preparing a purchase specification.
- The characteristics are the values at rated voltage (12 V or 24 V), and normal temperature and humidity.
- The life expectancy of CUDC12B4Q and CUDC12B4SQ products at rated voltage and in continuous operation is 20,000 hours at 60°C. (40,000 hours for other products).

General specification

Materials Used	Venturi: ABS and PBT synthetic resins Propeller: ABS and PBT synthetic resins Bearing: Both side shielded ball bearing
Motor	Brushless DC motor, Protection type: Current shut off by detecting lock state, automatically reset
Common Elec. Spec.	See pages G-11, G-12, G-13.
Standard Carton	60 to a carton of (450 x 380 x 300) mm, mass 12 kg

● Venturi shape

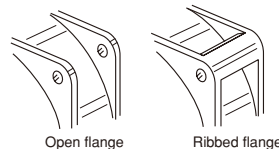

Use ribbed venturi with a reinforced corner when the venturi is mounted with screws. (The spacer is indicated in the model code by the letter 'R'.)

Standard airflow and static pressure characteristics (At rated voltage)

[By double chamber method]

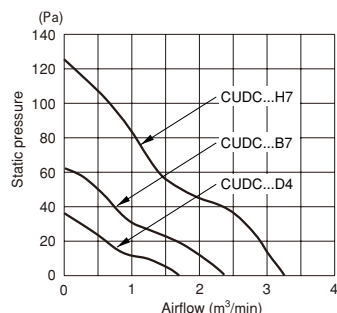

External dimensions in mm (inches)

● Lead wire type

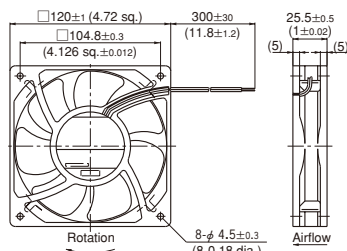

Wiring connection diagram

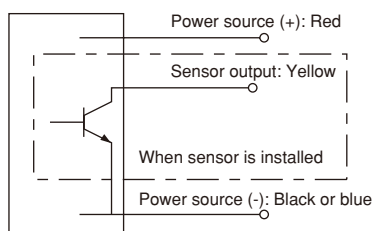

Mounting hole dimensions in mm (inches) [Recommendation]

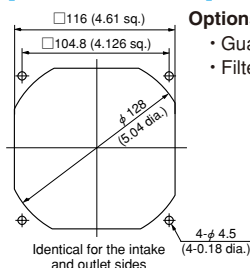

Options (sold separately)

- Guard: F120UL guard
- Filter: F120 filter

DC axial fan with sensor

Rated Voltage	Model Code		
12 V	CUDC12D4S	CUDC12B7S	CUDC12H7S
	CUDC12D4RS	CUDC12B7RS	CUDC12H7P
	CUDC12D4P	CUDC12B7P	
	CUDC12D4Q	CUDC12B4Q	
	CUDC12D4RQ	CUDC12B47Q	
24 V	CUDC24D4S	CUDC24B7S	CUDC24H7S
	CUDC24D4RQ	CUDC24B7RS	CUDC24H7P
	CUDC24D4Q	CUDC24B7P	
	CUDC24D4SQ	CUDC24B7Q	

- NIDEC SERVO can meet many of your requirements for customization, such as special connectors, other sensors not listed above, variable speed specifications, and other modifications. Please contact NIDEC SERVO during your product planning and development stage.
- The listed products are registered in the following overseas standards files, UL/CUL:48889, CSA:LR49399 (only available in D speed), TUV:R9451586
- 3D data is also available at our web2-CAD site (www.cadenas.co.jp).

GentleTyphoon™
D1225C



□ 120 × 25 (□ 4.7" × 1.0")

Max. airflow: 1.65 m³/min
Max. static pressure: 20 Pa
Mass: 200g

Fan model code

D1225C12B4AZ-00

D1225C12B5AZ-00

D1225C12B6AP-00

D1225C12B6AS-00

D1225C12B6AZ-00

D1225C24B4AZ-00

D1225C24B5AZ-00

Features

- Wide low-noise range (noise reduced in high density devices)
- 2-way vibration reduction (lowers resonant noise of entire device)
- Energy Efficient (wide reduction compared to previous model)
- Design to improve sound (for low speed applications)
- Sensors Available (lock, pulse)
- Variable speed available (PWM, voltage resistance)

Standard specification

Max. Airflow		Max. Static Pressure		Noise	Speed	Voltage Spec. V		Current mA		Model Code	Operating Temp. Range °C
m ³ /min	CFM	Pa	inH ₂ O	dB	r/min	Rating	Operating Range	Rating	Starting		
1.95	69	28	0.113	30*	2150	12	5.0-13.2	123	530	D1225C12B6AZ-00	-10 ~ +60
1.65	58	20	0.081	26*	1850	12	5.0-13.2	83	360	D1225C12B5AZ-00	
						24	12.0-26.4	45	190	D1225C24B5AZ-00	
1.30	46	13	0.051	19*	1450	12	7.0-13.2	49	210	D1225C12B4AZ-00	
						24	12.0-26.4	29	100	D1225C24B4AZ-00	

*Noise values shown (at 1m) were converted as follows subtract 12dB from actual noise measurements taken at 25cm (as shown in the noise graph below).

- Figures in the table are average measured values. Please request the product delivery specification when preparing a purchase specification.
- The characteristics are the values at rated voltage (12 V or 24 V), and normal temperature and humidity.
- the only venturi shape available for these products is ribbed flange.
- Depending on quantities, Nidec Servo can meet many of your requirements for customization, such as special connectors, sensors, variable speed specifications and other modifications. Please contact Nidec Servo for more information.
- This fan is specially designed for long life. At rated voltage and in continuous operation the expected life is 60,000 hours at 60° C, (100,000 hours at 35° C), (5,6 speed model ; 55,000 hours at 60° C).

General specification

Materials Used	Venturi: PBT-ABS synthetic resins Propeller: PBT-ABS synthetic resins Bearing: Both side shielded ball bearing
Motor	Brushless DC motor, Protection type: Current shut off by detecting lock state, automatically reset
Common Elec. Spec.	See pages G-11, G-12, G-13.
Standard Carton	60 to a carton of (450 x 380 x 300) mm, mass 13 kg

- 8 pockets (2 each provided in 4 places on flanged ribs) hold the M4 nuts (not included), and make for easy attachment.

Standard airflow and static pressure characteristics (At rated voltage)

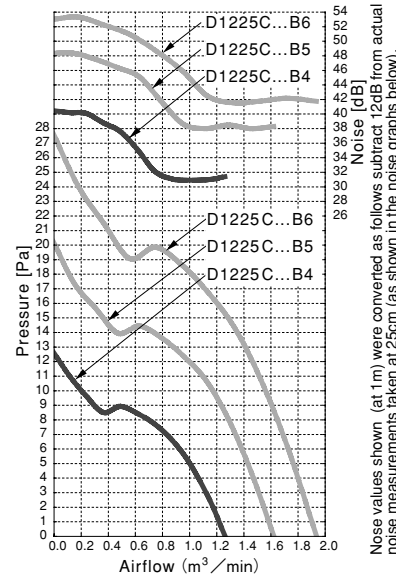

Wiring connection diagram

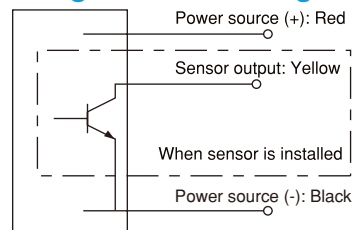

DC axial fan with sensor

Rated Voltage	Model Code
12 V	D1225C12B6AP-00
	D1225C12B6AS-00

- NIDEC SERVO can meet many of your requirements for customization, such as special connectors, other sensors not listed above, variable speed specifications, and other modifications. Please contact NIDEC SERVO during your product planning and development stage.
- The listed products are registered in the following overseas standards files, UL/cUL: E48889, TUV: R50004410

External dimensions in mm (inches)

● Lead wire type

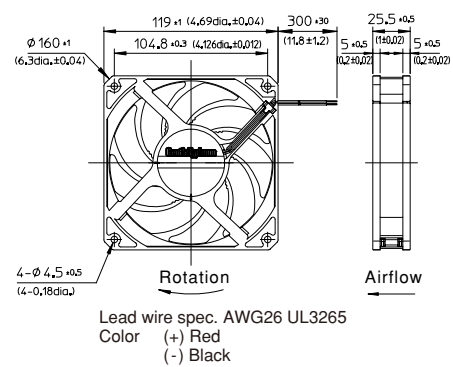

Mounting hole dimensions in mm (inches)
[Recommendation]

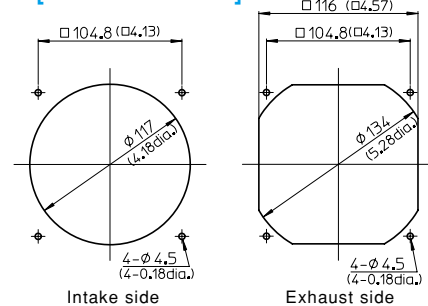

Options (sold separately)

- Guard: F120UL guard
- Filter: F120 filter

DC Axial Fan

CNDC



□ 120 × 38 (□ 4.7" × 1.5")
Max. airflow: 4.4 m³/min
Max. static pressure: 160 Pa
Mass: 250 g

Fan model code

- CNDC12B7
- CNDC12B7P
- CNDC12B7S
- CNDC12D7
- CNDC12D7P
- CNDC12D7V
- CNDC12H7
- CNDC12U7
- CNDC12Z7
- CNDC12Z7P
- CNDC12Z7Q
- CNDC12Z7S
- CNDC24B7
- CNDC24B7P
- CNDC24B7Q
- CNDC24B7S
- CNDC24B7SQ
- CNDC24B7V
- CNDC24B7VS
- CNDC24D7
- CNDC24D7Q
- CNDC24D7S
- CNDC24H7
- CNDC24U7
- CNDC24Z7
- CNDC24Z7P
- CNDC24Z7Q
- CNDC24Z7S
- CNDC24Z7V
- CNDC48B7
- CNDC48B7P
- CNDC48B7S
- CNDC48Z7
- CNDC48Z7P
- CNDC48Z7S
- CNDC48Z7V

Standard specification

Max. Airflow m ³ /min	Max. Static Pressure CFM Pa	Noise inH ₂ O dB	Speed min ⁻¹	Input W	Voltage Spec. V		Current mA		Model Code		Operating Temp. Range °C		
					Rating	Operating Range	Rating	Starting	Open Flange	With Spacer			
4.4	155	160	0.64	52	3800	12	8.4-13.8	930	2100	CNDC12U7	-20 ~ +70		
						10.8	24	19.2-27.6	450	2000		CNDC24U7	
4.0	141	140	0.56	51	3550	12	8.4-13.8	760	2080	CNDC12H7			
						9.4	24	19.2-27.6	390	1970		CNDC24H7	
3.5	124	105	0.42	49	3200	12	7.2-13.8	710	2350	CNDC12Z7			
						9.0	24	12-27.6	370	1200		CNDC24Z7	CNDC24Z7V
						10.0	48	24-55.2	210	530		CNDC48Z7	CNDC48Z7V
2.8	99	70	0.28	40	2650	12	7.2-13.8	380	1330	CNDC12B7			
						4.8	24	12-27.6	200	640		CNDC24B7	CNDC24B7V
						6	48	24-55.2	120	340		CNDC48B7	
2.1	74	44	0.18	32	1950	12	8.4-13.8	200		CNDC12D7		CNDC12D7V	
						2.6	24	14.4-27.6	110			CNDC24D7	

- Figures in the table are average measured values. Please request the product delivery specification when preparing a purchase specification.
- The characteristics are the values at rated voltage (12 V, 24 V or 48 V), and normal temperature and humidity.
- The life expectancy of CNDC-Z speed products at rated voltage and in continuous operation is 30,000 hours at 60°C. (40,000 hours for other products)

General specification

With Spacer	Venturi: ABS and PBT synthetic resins Propeller: ABS and PBT synthetic resins Bearing: Both side shielded ball bearing
Motor	Brushless DC motor, Protection type: Current shut off by detecting lock state, automatically reset
Common Elec. Spec.	See pages G-11, G-12, G-13.
Standard Carton	40 to a carton of (450 x 380 x 300) mm, mass 12 kg

● Venturi shape

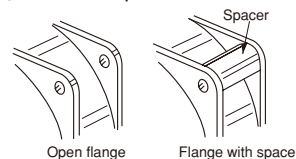

Use the reinforced product with spacer when the venturi is mounted with screws. (The spacer is indicated in the model code by the letter 'V'.)

Standard airflow and static pressure characteristics (At rated voltage)

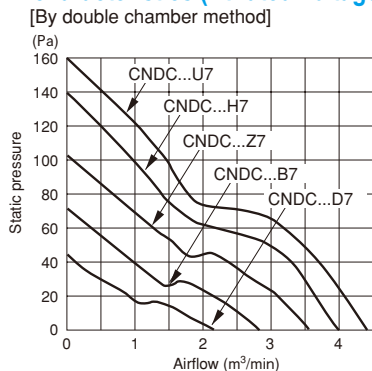

External dimensions in mm (inches)

- Lead wire type Lead wire spec. AWG24 UL1007 or UL3266
Color (+) Red (-) Black (CNDC□D7: Blue)

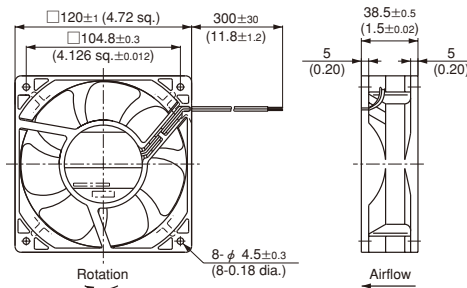

Wiring connection diagram

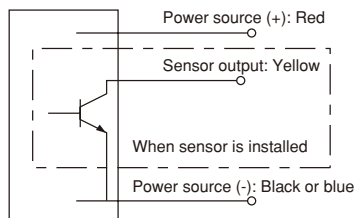

Mounting hole dimensions in mm (inches)
[Recommendation]

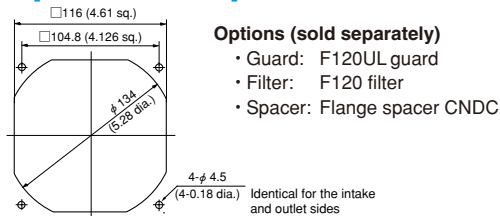

DC axial fan with sensor

Rated Vol.	Model Code		
12 V	CNDC12D7P	CNDC12B7S CNDC12B7P	CNDC12Z7S CNDC12Z7Q
	CNDC24D7S CNDC24D7Q	CNDC24B7S CNDC24B7VS CNDC24B7P CNDC24B7Q CNDC24B7SQ	CNDC24Z7S CNDC24Z7P CNDC24Z7Q
24 V		CNDC48B7S CNDC48B7P	CNDC48Z7S CNDC48Z7P

- NIDEC SERVO can meet many of your requirements for customization, such as special connectors, other sensors not listed above, variable speed specifications, and other modifications. Please contact NIDEC SERVO during your product planning and development stage.
- The listed products are registered in the following overseas standards files, UL/cUL: E48889 (Excep H, U speed models), CSA: LR49399 (H, U speed model only), TUV: R9451586
- 3D data is also available at our web2-CAD site (www.cadenas.co.jp).

DC Axial Fan
D1238T



□ 120 × 38 (□ 4.7" × 1.5")
Max. airflow: 4.4 m³/min
Max. static pressure: 160 Pa
Mass: 290 g

■ **Features**

- Power saving
- Low noise
- High airflow models, featuring an aerodynamic design inheriting the design concept of Silent Fans and incorporating a newly developed high-efficiency motor.
- Interchangeable with currently installed box fans.

Fan model code

- D1238T12B6AZ-00
- D1238T12B7AP-00
- D1238T12B7AZ-00
- D1238T24B7AS-00
- D1238T24B7AZ-00
- D1238T48B6AP-00
- D1238T48B6AS-00
- D1238T48B6AZ-00
- D1238T48B7AP-00
- D1238T48B7AS-00
- D1238T48B7AZ-00
- D1238T48B7CZ-00

■ **Standard specification**

Max. Airflow m ³ /min	Max. Static Pressure CFM	Max. Static Pressure Pa	Noise inH ₂ O	Noise dB	Speed r/min	Voltage Spec. V		Current mA		Model Code	Operating Temp. Range °C	
						Rating	Operating Range	Rating	Starting			
4.4	155	160	0.64	50	4000	10.0	12	8.4-13.8	830	1500	D1238T12B7AZ-00	-20 ~ +70
						11.7	24	18.0-27.6	490	1040	D1238T24B7AZ-00	
						11.0	48	33.6-55.2	230	350	D1238T48B7AZ-00	
4.0	141	130	0.52	47.5	3600	7.5	12	8.4-13.8	630	1050	D1238T12B6AZ-00	
						8.5	48	33.6-55.2	180	330	D1238T48B6AZ-00	

- Figures in the table are average measured values. Please request the product delivery specification when preparing a purchase specification.
- The characteristics are the values at rated voltage (12V, 24V or 48V), and normal temperature and humidity.

■ **General specification**

Materials Used	Venturi: ABS and PBT synthetic resins Propeller: ABS and PBT synthetic resins Bearing: Both side shielded ball bearing
Motor	Brushless DC motor, Protection type: OverCurrent detection and automatic resetting by current limiting
Common Elec. Spec.	See pages G-11, G-12, G-13.

● **Fan mounting**

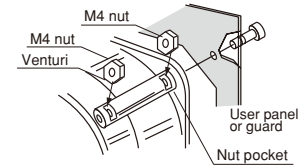

M4 nut pockets (2 each) provided in 4 places for easy mounting. (The customer is to provide nuts)
Front guard can be mounted easily.

■ **Standard airflow and static pressure characteristics (At rated voltage)**

[By double chamber method]

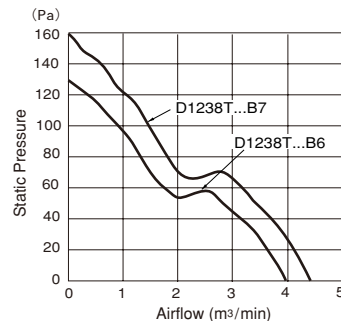

■ **External dimensions in mm (inches)**

● **Lead wire type**

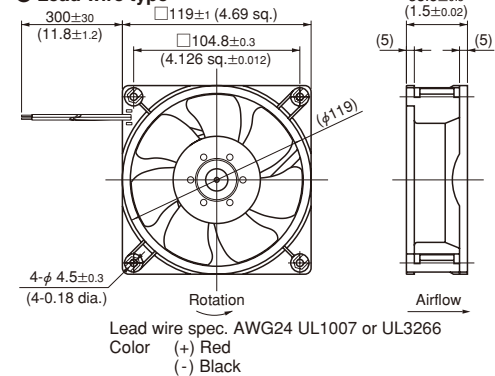

■ **Wiring connection diagram**

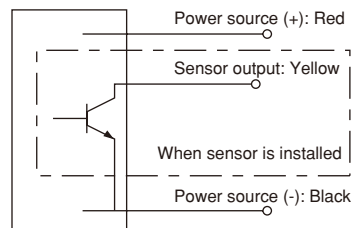

■ **Mounting hole dimensions in mm (inches)**
[Recommendation]

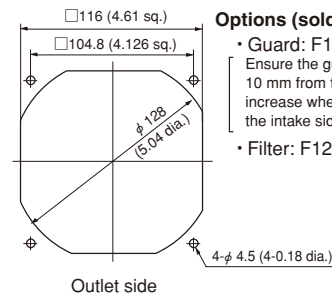

Options (sold separately)

- Guard: F120UL guard
Ensure the guard is situated more than 10 mm from the fan to minimize noise increase when mounting a guard on the intake side. See page G-9.
- Filter: F120 filter

DC axial fan with sensor

Rated Vol.	Model Code
12 V	D1238T12B7AP-00
24 V	D1238T24B7AS-00
48 V	D1238T48B6AS-00
	D1238T48B6AP-00

- NIDEC SERVO can meet many of your requirements for customization, such as special connectors, other sensors not listed above, variable speed specifications, and other modifications. Please contact NIDEC SERVO during your product planning and development stage.
- The listed products are registered in the following overseas standards files, UL/cUL: E48889, TUV: R50004410 (The 7 speed is only available in the 24 V ver).
- An electronic version of the NIDEC SERVO catalog can be forwarded upon request. 3D data is also available at our web2-CAD site (www.cadenas.co.jp).

DC Axial Fan

D1238B



□ 120 × 38 (□ 4.7" × 1.5")

Max. airflow: 6.2 m³/min
Max. static pressure: 300 Pa
Mass: 430 g

Fan model code

- D1238B12B7AZ-00
- D1238B12B8AP-00
- D1238B12B8AZ-00
- D1238B12B9AP-00
- D1238B12B9AZ-00
- D1238B24B7AP-00
- D1238B24B7AZ-00
- D1238B24B8AS-00
- D1238B24B8AZ-00
- D1238B24B9AP-00
- D1238B24B9AS-00
- D1238B24B9AZ-00
- D1238B24BAAZ-00
- D1238B48B7AP-00
- D1238B48B7AZ-00
- D1238B48B8AP-00
- D1238B48B8AS-00
- D1238B48B8AZ-00
- D1238B48B9AP-00
- D1238B48B9AS-00
- D1238B48B9AZ-00
- D1238B48BAAP-00
- D1238B48BAAS-00
- D1238B48BAAZ-00

Standard specification

Max. Airflow m ³ /min	Max. Static Pressure CFM	Max. Static Pressure Pa	Noise inH ₂ O	Noise dB	Speed min ⁻¹	Input W		Voltage Spec. V		Current mA		Model Code	Operating Temp. Range °C
						Rating	Operating Range	Rating	Starting	Rating	Starting		
6.2	219	300	1.21	62	5500	26.4	24	18-27.6	1100	2700	D1238B24BAAZ-00	-20 ~ +70	
						26.4	48	36-55.2	560		D1238B48BAAZ-00		
5.25	185	250	1.01	59	4900	19.8	12	8.4-13.8	1650	5200	D1238B12B9AZ-00		
						19.7	24	16.8-27.6	820	2600	D1238B24B9AZ-00		
						19.2	48	36-55.2	400	950	D1238B48B9AZ-00		
						14.4	12	8.4-13.8	1200		D1238B12B8AZ-00		
4.8	169	185	0.74	56	4400	13.9	24	16.8-27.6	580	1850	D1238B24B8AZ-00		
						15.4	48	36-55.2	320		D1238B48B8AZ-00		
4.4	155	160	0.64	54	4000	14.4	12	8.4-13.8	1200		D1238B12B7AZ-00		
						14.4	24	16.8-27.6	600	1600	D1238B24B7AZ-00		
						12.0	48	36-55.2	250	1600	D1238B48B7AZ-00		

● Figures in the table are average measured values. Please request the product delivery specification when preparing a purchase specification.
● The characteristics are the values at rated voltage (12 V, 24 V or 48 V), and normal temperature and humidity.

General specification

Materials Used	Venturi: Aluminum alloy die castings Propeller: ABS and PBT synthetic resins Bearing: Both side shielded ball bearing
Motor	Brushless DC motor, Protection type: Overcurrent detection and automatic resetting by current limiting
Common Elec. Spec.	See pages G-11, G-12, G-13.

Standard airflow and static pressure characteristics (At rated voltage)

[By double chamber method]

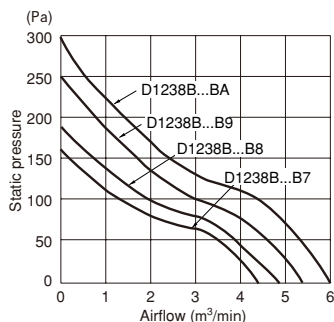

External dimensions in mm (inches)

Lead wire type

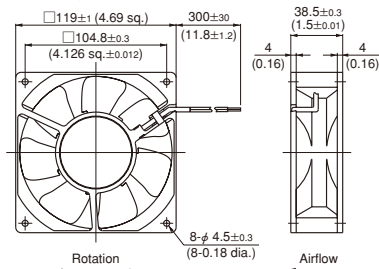

Lead wire spec. AWG24 UL1007 or UL3266
Color (+) Red
(-) Black

Wiring connection diagram

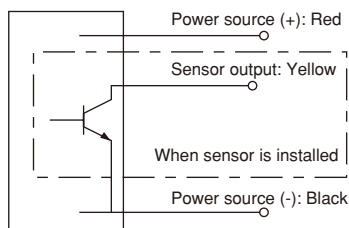

Mounting hole dimensions in mm (inches)
[Recommendation]

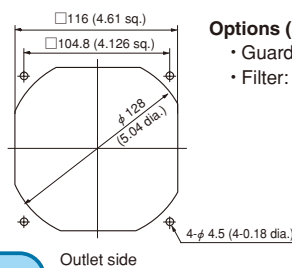

Options (sold separately)
• Guard: F120UL guard
• Filter: F120 filter

Customized fans with a higher airflow are also available.
Please contact NIDEC SERVO for more information.

DC axial fan with sensor

Rated Vol.	Model Code			
12 V		D1238B12B8AP-00	D1238B12B9AP-00	
		D1238B24B8AS-00	D1238B24B9AS-00	
24 V	D1238B24B7AP-00		D1238B24B9AP-00	
		D1238B48B8AS-00	D1238B48B9AS-00	D1238B48BAAS-00
48 V	D1238B48B7AP-00	D1238B48B8AP-00	D1238B48B9AP-00	D1238B48BAAP-00

● NIDEC SERVO can meet many of your requirements for customization, such as special connectors, other sensors not listed above, variable speed specifications, and other modifications. Please contact NIDEC SERVO during your product planning and development stage.
● The listed products are registered in the following overseas standards files, UL: E129458, CSA: LR49399, TUV: R50004410
● 3D data is also available at our web2-CAD site (www.cadenas.co.jp).

DC Axial Fan
D1338B



□ 127 × 38 (□ 5.0" × 1.5")
Max. airflow: 5.8 m³/min
Max. static pressure: 185 Pa
Mass: 410 g

Fan model code

- D1338B12B6AZ-00
- D1338B12B7AZ-00
- D1338B12B8AZ-00
- D1338B24B6AZ-00
- D1338B24B7AS-00
- D1338B24B7AZ-00
- D1338B24B8AP-00
- D1338B24B8AS-00
- D1338B24B8AZ-00
- D1338B48B6AP-00
- D1338B48B6AZ-00
- D1338B48B7AP-00
- D1338B48B7AS-00
- D1338B48B7AZ-00
- D1338B48B8AP-00
- D1338B48B8AS-00
- D1338B48B8AZ-00

Standard specification

Max. Airflow		Max. Static Pressure		Noise dB	Speed min ⁻¹	Input W	Voltage Spec. V		Current mA		Model Code	Operating Temp. Range °C
m ³ /min	CFM	Pa	inH ₂ O				Rating	Operating Range	Rating	Starting		
5.8	205	185	0.74	58	4500	19.8	12	8.4-13.8	1650		D1338B12B8AZ-00	-20 ~ +70
						19.7	24	16.8-27.6	820	2500	D1338B24B8AZ-00	
						21.1	48	36-55.2	440	940	D1338B48B8AZ-00	
5	177	150	0.60	54	3900	16.2	12	8.4-13.8	1350		D1338B12B7AZ-00	
						15.6	24	16.8-27.6	650		D1338B24B7AZ-00	
						16.8	48	36-55.2	350		D1338B48B7AZ-00	
4.6	162	130	0.52	51	3400	12	8.4-13.8	1000			D1338B12B6AZ-00	
						24	16.8-27.6	500	1600		D1338B24B6AZ-00	
						48	36-55.2	250	1150		D1338B48B6AZ-00	

- Figures in the table are average measured values. Please request the product delivery specification when preparing a purchase specification.
- The characteristics are the values at rated voltage (12 V, 24 V or 48 V), and normal temperature and humidity.

General specification

Materials Used	Venturi: Aluminum alloy die castings Propeller: ABS and PBT synthetic resins Bearing: Both side shielded ball bearing
Motor	Brushless DC motor, Protection type: Overcurrent detection and automatic resetting by current limiting
Common Elec. Spec.	See pages G-11, G-12, G-13.

Standard airflow and static pressure characteristics (At rated voltage)
[By double chamber method]

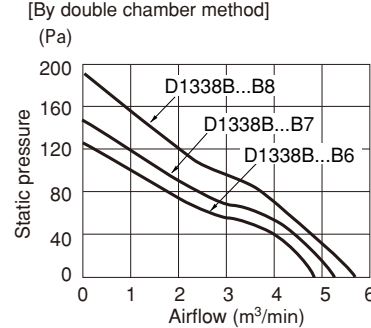

External dimensions in mm (inches)

● Lead wire type

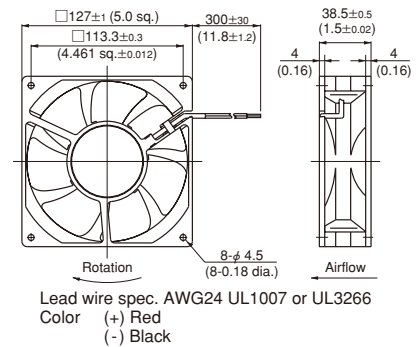

Wiring connection diagram

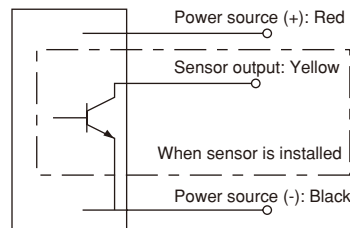

Mounting hole dimensions in mm (inches)
[Recommendation]

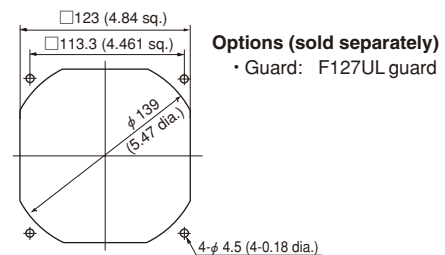

DC axial fan with sensor

Rated Vol.	Model Code		
24 V	D1338B24B7AS-00	D1338B24B8AS-00	D1338B24B8AP-00
	D1338B48B7AS-00	D1338B48B8AS-00	D1338B48B8AP-00
48 V	D1338B48B6AP-00	D1338B48B7AP-00	D1338B48B8AP-00

- NIDEC SERVO can meet many of your requirements for customization, such as special connectors, other sensors not listed above, variable speed specifications, and other modifications. Please contact NIDEC SERVO during your product planning and development stage.
- The listed products are registered in the following overseas standards files, UL: E48889, CSA: LR49399, TUV: 50004410
- 3D data is also available at our web2-CAD site (www.cadenas.co.jp).

DC Axial Fan
D1338S



□ 127 × 38 (□ 5.0" × 1.5")
Max. airflow: 5.1 m³/min
Max. static pressure: 185 Pa
Mass: 495 g

Fan model code

- D1338S48B7AP-00
- D1338S48B7AS-00
- D1338S48B7AZ-00

Standard specification

Max. Airflow		Max. Static Pressure		Noise	Speed	Input	Voltage Spec. V		Current mA		Model Code	Operating Temp. Range °C
m ³ /min	CFM	Pa	inH ₂ O	dB	min ⁻¹	W	Rating	Operating Range	Rating	Starting		
5.1	180	185	0.74	53	4300	16.8	48	36-55.2	350	950	D1338S48B7AZ-00	-20 ~ +70

- Figures in the table are average measured values. Please request the product delivery specification when preparing a purchase specification.
- The characteristics are the values at rated voltage (48 V), and normal temperature and humidity.

General specification

Materials Used	Venturi: Aluminum alloy die castings Propelle: ABS and PBT synthetic resins Bearing: Both side shielded ball bearing
Motor	Brushless DC motor, Protection type: Overcurrent detection and automatic resetting by current limiting
Common Elec. Spec.	See pages G-11, G-12, G-13.

Standard airflow and static pressure characteristics (At rated voltage)

[By double chamber method]

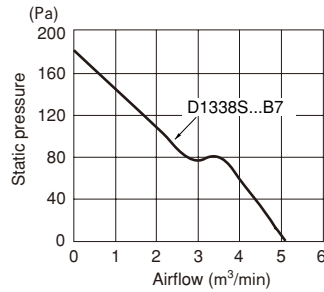

External dimensions in mm (inches)

● Lead wire type

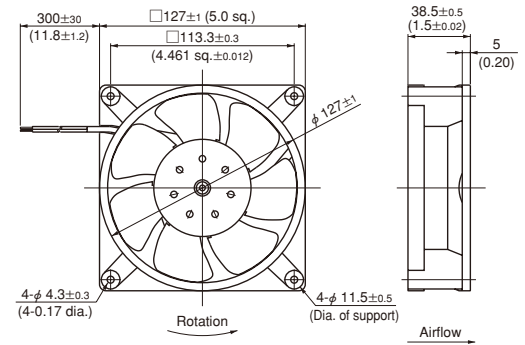

Lead wire spec. AWG24 UL1007 or UL3266
Color (+) Red
(-) Black

Wiring connection diagram

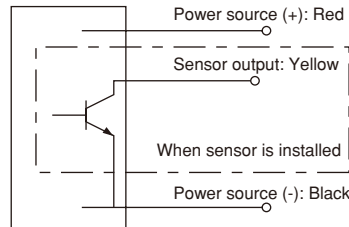

Mounting hole dimensions in mm (inches)
[Recommendation]

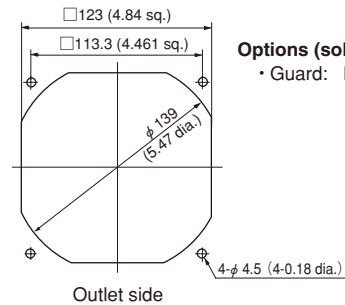

Options (sold separately)
• Guard: F127UL guard

DC axial fan with sensor

Rated Vol.	Model Code
48 V	D1338S48B7AS-00
	D1338S48B7AP-00

- NIDEC SERVO can meet many of your requirements for customization, such as special connectors, other sensors not listed above, variable speed specifications, and other modifications. Please contact NIDEC SERVO during your product planning and development stage.

DC Axial Fan
D1751M



$\phi 172 \times 150 \times 51$
($\phi 6.8" \times 6.0" \times 2.0"$)
Max. airflow : 14.2 m³/min
Max. static pressure : 580 Pa
Mass : 780 g

Fan model code

- D1751M12B1AS-00
- D1751M12B1AZ-00
- D1751M12B2AP-00
- D1751M12B2AS-00
- D1751M12B2AZ-00
- D1751M12B3AP-00
- D1751M12B3AS-00
- D1751M12B3AZ-00
- D1751M12B4AP-00
- D1751M12B4AS-00
- D1751M12B4AZ-00
- D1751M24B1AP-00
- D1751M24B2AP-00
- D1751M24B2AS-00
- D1751M24B2AZ-00
- D1751M24B3AP-00
- D1751M24B3AS-00
- D1751M24B3AZ-00
- D1751M24B4AP-00
- D1751M24B4AS-00
- D1751M24B4AZ-00
- D1751M24B7AP-00
- D1751M24B7AZ-00
- D1751M24B7ZP-00
- D1751M24B8ZP300
- D1751M48B2AP-00
- D1751M48B2AS-00
- D1751M48B2AZ-00
- D1751M48B3AP-00
- D1751M48B3AS-00
- D1751M48B3AZ-00
- D1751M48B4AP-00
- D1751M48B4ZP-00
- D1751M48B5ZP-00
- D1751M48B6AP-00
- D1751M48B6ZP-00
- D1751M48B7ZP-00
- D1751M48B8ZP-00
- D1751M48B9ZP-00

Standard specification

Max. airflow m ³ /min	CFM	Max. static pressure		Noise dB	Speed min ⁻¹	Voltage spec. V		Current mA		Model code	Operating temp. range C	
		Pa	inH ₂ O			Rating	Operating Range	Rating	Starting			
14.2	501	580	2.33	75	6800	24	16-28	4600	6900	D1751M24B9ZP300 D1751M48B9ZP-00	-20 ~ +60	
						48	36-60	2300	6000			
12.7	448	510	2.05	72	6100	24	16-28	3400	4800	D1751M24B8ZP300 D1751M48B8ZP-00		
						48	36-60	1650	3500			
11.4	402	410	1.65	69	5400	24	12-27.6	2450	5600	D1751M24B7ZP-00 D1751M48B7ZP-00		
						48	36-60	1200	2350			
10.2	360	315	1.27	64	4800	24	12-27.6	1800	3200	D1751M24B6ZP-00 D1751M48B6ZP-00		
						48	36-60	820	1800			
9	318	260	1.04	61	4200	24	12-27.6	1200	2200	D1751M24B5AP-00 D1751M48B5ZP-00		
						48	36-60	600	1150			
8	282	205	0.82	57	3800	12	8.4-13.8	1840	3800	D1751M12B4AZ-00 D1751M24B4ZP-00		-20 ~ +70
						24	12-27.6	900	2200			
6.8	240	155	0.62	54	3200	48	36-60	450	860	D1751M48B4ZP-00 D1751M12B3AZ-00		
						12	8.4-13.8	1200	3400			
5.8	205	120	0.48	49	2800	24	12-27.6	600	2400	D1751M24B3AZ-00 D1751M48B3AZ-00		
						48	28.8-55.2	310	900			
4.2	148	67	0.27	41	2000	12	8.4-13.8	800	2900	D1751M12B2AZ-00 D1751M24B2AZ-00		
						24	12-27.6	400	1900			
						48	28.8-55.2	210	700	D1751M48B2AZ-00 D1751M12B1AZ-00		
						12	8.4-13.8	390	2200			
						24	12-27.6	200	1150	D1751M24B1AP-00		

- Figures in the table are average measured values. Please request the product delivery specification when preparing a purchase specification.
- The characteristics are the values at rated voltage (12 V, 24 V, 48 V), and normal temperature and humidity.

General specification

Materials Used	Venturi: Aluminum alloy die castings Propelle: ABS and PBT synthetic resins Bearing: Both side shielded ball bearing
Motor	Brushless DC motor, Protection type: Overcurrent detection and automatic resetting by current limiting
Common Elec. Spec.	See pages G-11, G-12, G-13.
Standard Carton	12 to a carton of (450 x 380 x 220)mm, mass 10kg

Mouting hole dimensions in mm (inches)[Recommendation]

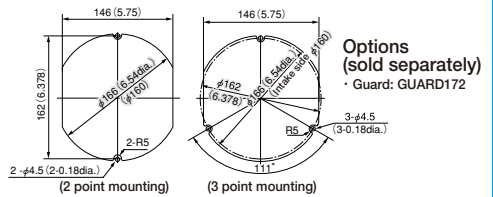

Standard airflow and static pressure characteristics (At rated voltage)

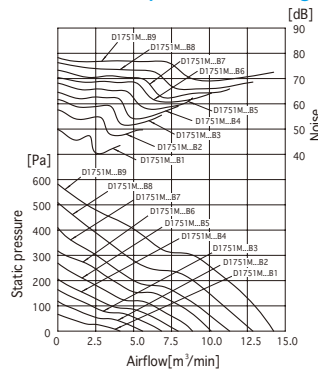

PWM speed control specification

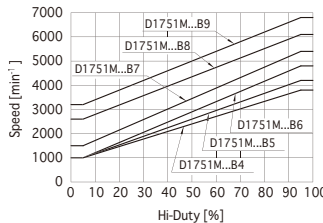

External dimensions in mm (inches)

● Lead wire type

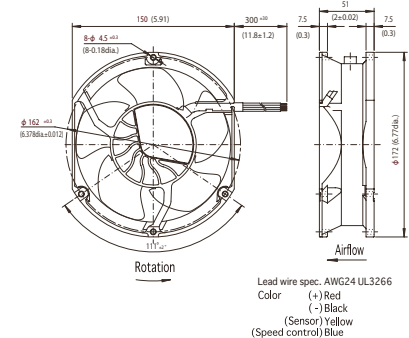

Speed performance (At rated vol., Air specification (Room temperature))

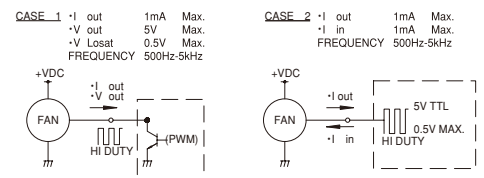

DC axial fan with sensor

Rated Vol.	Model Code									
12 V	D1751M12B1AS-00	D1751M12B2AP-00	D1751M12B3AP-00	D1751M12B4AP-00						
		D1751M12B2AS-00	D1751M12B3AS-00	D1751M12B4AS-00						
24V	D1751M24B1AP-00	D1751M24B2AP-00	D1751M24B3AP-00	D1751M24B4AP-00	D1751M24B5ZP-00	D1751M24B6ZP-00	D1751M24B7AP-00	D1751M24B8ZP300	D1751M24B9ZP300	
		D1751M24B2AS-00	D1751M24B3AS-00	D1751M24B4ZP-00			DD1751M24B7ZP-00			
48V		D1751M48B2AP-00	D1751M48B3AP-00	D1751M48B4AP-00	D1751M48B5ZP-00	D1751M48B6AP-00	D1751M48B7ZP-00	D1751M48B8ZP-00	D1751M48B9ZP-00	
		D1751M48B2AS-00	D1751M48B3AS-00	D1751M48B4ZP-00		D1751M48B6ZP-00				

- NIDEC SERVO can meet many of your requirements for customization, such as special connectors, other sensors not listed above, variable speed specifications, and other modifications. Please contact NIDEC SERVO during your product planning and development stage.
- PWM (pulse width modulation) allowing for variable speed control is available in some models (reference the G-51 spec.)
- The listed products are registered in the following overseas standards files, UL/cUL: E48889, TUV: R50004410

DC Axial Fan
D1751S



$\phi 172 \times 51$
($\phi 6.8" \times 2.0"$)
Max. airflow : 14.2 m³/min
Max. static pressure : 640 Pa
Mass : 830 g

Fan model code

D1751S12B1AP-00

D1751S12B1AS-00

D1751S12B1AZ-00

D1751S12B2AP-00

D1751S12B2AS-00

D1751S12B2AZ-00

D1751S12B3AP-00

D1751S12B3AS-00

D1751S12B3AZ-00

D1751S12B4AP-00

D1751S12B4AS-00

D1751S12B4AZ-00

D1751S24B1AP-00

D1751S24B1AS-00

D1751S24B1AZ-00

D1751S24B2AP-00

D1751S24B2AS-00

D1751S24B2AZ-00

D1751S24B3AP-00

D1751S24B3AS-00

D1751S24B3AZ-00

D1751S24B4ZP-00

D1751S24B5ZP-00

D1751S24B6AP-00

D1751S24B6ZP-00

D1751S24B7AP-00

D1751S24B7AZ-00

D1751S24B7ZP-00

D1751S24B8ZP300

D1751S24B9ZP300

D1751S48B2AP-00

D1751S48B2AS-00

D1751S48B2AZ-00

D1751S48B3AP-00

D1751S48B3AS-00

D1751S48B3AZ-00

D1751S48B4ZP-00

D1751S48B5ZP-00

D1751S48B6ZP-00

D1751S48B7ZP-00

D1751S48B8AZ-00

D1751S48B8ZP-00

D1751S48B9ZP-00

Standard specification

Max. airflow m ³ /min	CFM	Max. static pressure		Noise dB	Speed min ⁻¹	Voltage spec. V		Current mA		Model code	Operating temp. range °C	
		Pa	inH ₂ O			Rating	Operating Range	Rating	Starting			
14.2	501	640	2.75	68	6800	24	16-28	4600	6900	D1751S24B9ZP300	-20 ~ +60	
						48	36-60	2300	6000			D1751S48B9ZP-00
12.7	448	520	2.09	65	6100	24	16-28	3400	4800	D1751S24B8ZP300		
						48	36-60	1650	3500			D1751S48B8AZ-00
11.4	402	435	1.75	62	5400	24	12-27.6	2450	5600	D1751S24B7AZ-00		
						48	36-60	1200	2350			D1751S48B7ZP-00
10.2	360	335	1.35	59	4800	24	12-27.6	1800	3200	D1751S24B6AZ-00		
						48	36-60	820	1800			D1751S48B6ZP-00
9	318	270	1.08	56	4200	24	12-27.6	1200	2200	D1751S24B5ZP-00		
						48	36-60	600	1150			D1751S48B5ZP-00
8	282	220	0.88	53.5	3800	12	8.4-13.8	1840	3800	D1751S12B4AZ-00		-20 ~ +70
						24	12-27.6	900	2200			
6.8	240	165	0.66	48	3200	48	36-60	450	860	D1751S48B4ZP-00		
						12	8.4-13.8	1200	3400		D1751S12B3AZ-00	
5.8	205	125	0.50	44	2800	24	12-27.6	600	2400	D1751S24B3AZ-00		
						48	28.8-55.2	310	900		D1751S48B3AZ-00	
4.2	148	70	0.28	36	2000	12	8.4-13.8	800	2900	D1751S12B2AZ-00		
						24	12-27.6	400	1900		D1751S24B2AZ-00	
						48	28.8-55.2	210	700	D1751S48B2AZ-00		
						12	8.4-13.8	390	2200		D1751S12B1AZ-00	
						24	12-27.6	200	1150	D1751S24B1AZ-00		

● Figures in the table are average measured values. Please request the product delivery specification when preparing a purchase specification.
● The characteristics are the values at rated voltage (12 V, 24 V, 48 V), and normal temperature and humidity.

General specification

Materials Used	Venturi: Aluminum alloy die castings Propelle: ABS and PBT synthetic resins Bearing: Both side shielded ball bearing
Motor	Brushless DC motor, Protection type: Overcurrent detection and automatic resetting by current limiting
Common Elec. Spec.	See pages G-11, G-12, G-13.
Standard Carton	12 to a carton of (450 x 380 x 220)mm, mass 10.5kg

Standard airflow and static pressure characteristics (At rated voltage)

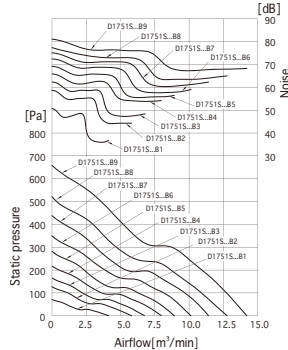

PWM speed control specification

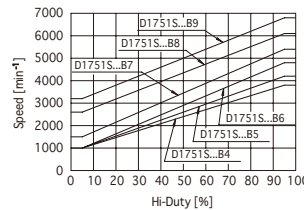

Mouting hole dimensions in mm (inches)[Recommendation]

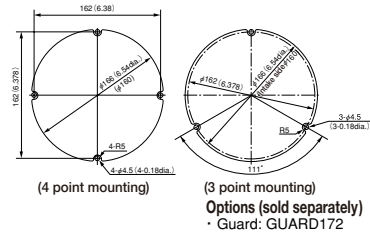

External dimensions in mm (inches)

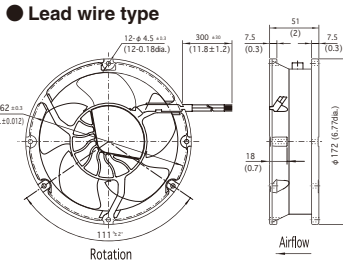

Speed Performance (At rated vol.Air) Specification (Room temperature)

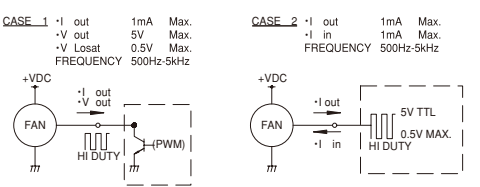

DC axial fan with sensor

Rated Vol.	Model Code									
12 V	D1751S12B1AP-00	D1751S12B2AP-00	D1751S12B3AP-00	D1751S12B4AP-00						
	D1751S12B1AS-00	D1751S12B2AS-00	D1751S12B3AS-00	D1751S12B4AS-00						
24V	D1751S24B1AP-00	D1751S24B2AP-00	D1751S24B3AP-00	D1751S24B4ZP-00	D1751S24B5ZP-00	D1751S24B6AP-00	D1751S24B7AP-00	D1751S24B8ZP300	D1751S24B9ZP300	
	D1751S24B1AS-00	D1751S24B2AS-00	D1751S24B3AS-00	D1751S24B4ZR-13		D1751S24B6ZP-00	D1751S24B7ZP-00			
48V		D1751S48B2AP-00	D1751S48B3AP-00	D1751S48B4ZP-00	D1751S48B5ZP-00	D1751S48B6ZP-00	D1751S48B7ZP-00	D1751S48B8ZP-00	D1751S48B9ZP-00	
		D1751S48B2AS-00	D1751S48B3AS-00							

● NIDEC SERVO can meet many of your requirements for customization, such as special connectors, other sensors not listed above, variable speed specifications, and other modifications. Please contact NIDEC SERVO during your product planning and development stage.
● PWM (pulse width modulation) allowing for variable speed control is available in some models (reference the G-51 spec.)
● The listed products are registered in the following overseas standards files, UL/cUL: E48889, TUV: R50004410

DC Axial Fan
Fixed Blade Type
G0428C



□40×28 (□1.6"×1.1")
Max. airflow: 0.65 m³/min
Max. static pressure: 435 Pa
Mass: 50 g

Fan model code
G0428C12BAZP-00

Standard specification

Max. Airflow		Max. Static Pressure		Noise	Speed min ⁻¹		Voltage Spec. V		Current mA		Model Code	Operating Temp. Range °C
m ³ /min	CFM	Pa	inH ₂ O	dB	Max.	Min.	Rating	Operating Range	Rating	Starting		
0.65	22.9	435	1.75	55	16500	3000	12	7-13.2	570	1200	G0428C12BAZP-00	-20 ~ +60

- Figures in the table are average measured values. Please request the product delivery specification when preparing a purchase specification.
- The characteristics are the values at rated voltage (12 V), and normal temperature and humidity.
- Max. CFM and max static pressure points conclude at max rotational speed.

General specification

Materials Used	Venturi: ABS and PBT synthetic resins Propeller: ABS and PBT synthetic resins Bearing: Both side shielded ball bearing
Motor	Brushless DC motor, Protection type: Current shut off by detecting lock state, automatically reset
Common Elec. Spec.	See pages G-11, G-12, G-13.

Standard airflow and static pressure characteristics (At rated voltage)

[By double chamber method]

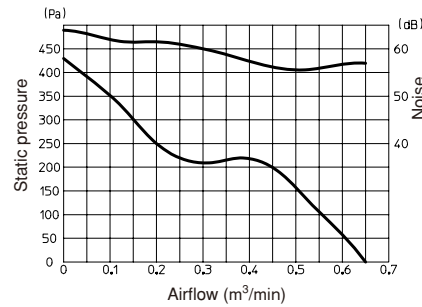

PWM speed control specification

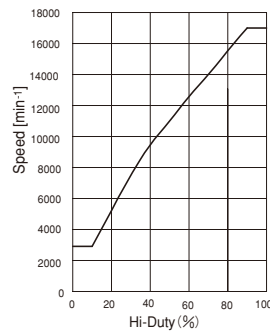

Mounting hole dimensions in mm (inches)
[Recommendation]

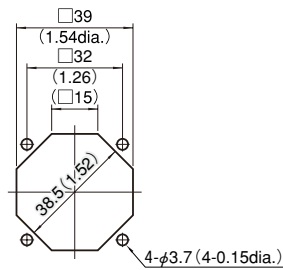

Identical for the intake and outlet sides

External dimensions in mm (inches)

● Lead wire type

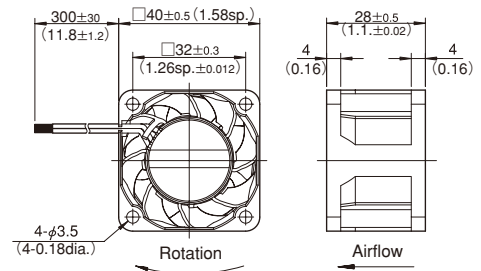

Lead wire spec. AWG26 UL3265
Color (+) Red
(-) Black
(Sensor) Yellow
(Speed Control) Blue

Speed performance (At rated vol., Air specification (Room temperature))

CASE 1 ·I out 1mA Max.
·V out 5V Max.
·V Losat 0.4V Max.
FREQUENCY 25kHz-30kHz

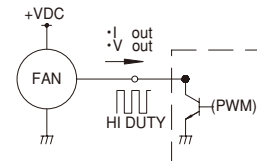

CASE 2 ·I out 1mA Max.
·I in 1mA Max.
FREQUENCY 25kHz-30kHz

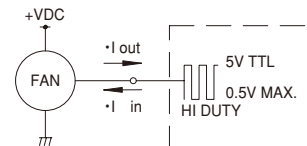

- NIDEC SERVO can meet many of your requirements for customization, such as special connectors, other sensors not listed above, variable speed specifications, and other modifications. Please contact NIDEC SERVO during your product planning and development stage.
- The listed products are registered in the following overseas standards files, UL/cUL: E48889, TUV: R50004410

DC Axial Fan
Fixed Blade Type
G0638D



□ 60×38 (□ 2.4"×1.5")
Max. airflow: 1.81 m³/min
Max. static pressure: 470 Pa
Mass: 130 g

Fan model code

G0638D12B7ZP-00

G0638D12B8ZP-00

G0638D12B9ZP-00

G0638D12BAZP-00

Standard specification

Max. airflow m ³ /min	Max. static pressure CFM	Pa	Noise inHzO	dB	Speed min ⁻¹		Voltage spec. V		Current mA		Model code	Operating Temp. Range°C
					Max.	Min.	Rating	Operating Range	Rating	Starting		
1.81	63.9	470	1.89	63	12000	3000	12	8.4-13.8	1660	2450	G0638D12BAZP-00	-20 ~ +60
1.60	56.5	365	1.47	59	10600	2500	12	8.4-13.8	1060	1800	G0638D12B9ZP-00	
1.40	49.4	290	1.17	56	9600	2200	12	8.4-13.8	800	1500	G0638D12B8ZP-00	
1.20	42.4	210	0.84	52	8250	1900	12	8.4-13.8	540	1100	G0638D12B7ZP-00	

- Figures in the table are average measured values. Please request the product delivery specification when preparing a purchase specification.
- The characteristics are the values at rated voltage (12 V), and normal temperature and humidity.
- Max. CFM and max static pressure points conclude at max rotational speed.

General specification

Materials Used	Venturi: ABS and PBT synthetic resins Propeller: ABS and PBT synthetic resins Bearing: Both side shielded ball bearing
Motor	Brushless DC motor, Protection type: Current shut off by detecting lock state, automatically reset
Common Elec. Spec.	See pages G-11, G-12, G-13.

● Venturi Shape



Open Flange

Standard airflow and static pressure characteristics (At rated voltage)

[By double chamber method]

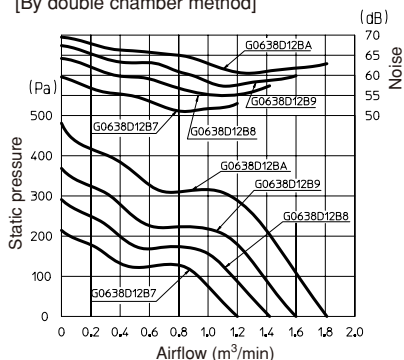

External dimensions in mm (inches)

● Lead wire type

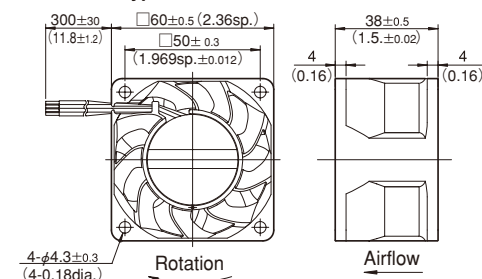

PWM speed control specification

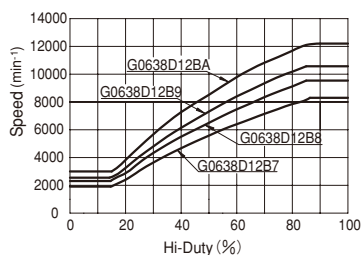

Speed performance (At rated vol., Air) specification (Room temperature)

CASE 1
-I out 1mA Max.
-V out 5V Max.
-V Losat 0.5V Max.
FREQUENCY 500kHz-5kHz

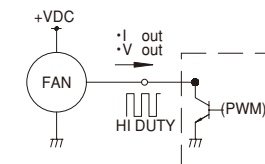

CASE 2
-I out 1mA Max.
-I in 1mA Max.
FREQUENCY 500kHz-5kHz

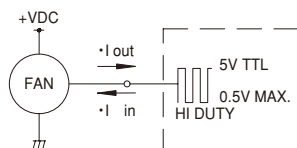

Mounting hole dimensions in mm (inches)
[Recommendation]

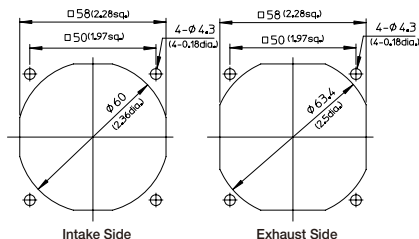

Options (sold separately)

- Guard: F60UL guard
- Filter: F60P filter

● NIDEC SERVO can meet many of your requirements for customization, such as special connectors, other sensors not listed above, variable speed specifications, and other modifications. Please contact NIDEC SERVO during your product planning and development stage.

Fans & Blowers

Axial

DC fans

Axial/centrifugal

Silent

AC fans

Axial

Centrifugal

Option

DC Axial Fan
Fixed Blade Type
G0838C



□ 80 × 38 (□ 3.2" × 1.5")
Max. airflow: 2.83 m³/min
Max. static pressure: 470 Pa
Mass: 230 g

Fan model code

G0838C12B7ZP-00

G0838C12B8ZP-00

G0838C12B9ZP-00

G0838C12BAZP-00

G0838C24B7ZP-00

G0838C24B8ZP-00

G0838C24B9ZP-00

G0838C24BAZP-00

Standard specification

Max. airflow m ³ /min	Max. static pressure CFM	Pa	inH ₂ O	Noise dB	Speed min ⁻¹		Voltage spec. V		Current mA		Model code	Operating Temp. Range°C
					Max.	Min.	Rating	Operating Range	Rating	Starting		
2.83	100	470	1.89	60	8000	1800	12	8.4-13.8	1700	3750	G0838C12BAZP-00	-20 ~ +70
							24	16.8-27.6	800	1650	G0838C24BAZP-00	
2.5	88	360	1.45	57	7200	1700	12	8.4-13.8	1200	3300	G0838C12B9ZP-00	
							24	16.8-27.6	600	1500	G0838C24B9ZP-00	
2.25	79	290	1.17	54	6400	1500	12	8.4-13.8	900	2900	G0838C12B8ZP-00	
							24	16.8-27.6	420	1300	G0838C24B8ZP-00	
2.0	71	220	0.88	50	5600	1200	12	8.4-13.8	600	2500	G0838C12B7ZP-00	
							24	16.8-27.6	300	1200	G0838C24B7ZP-00	

- Figures in the table are average measured values. Please request the product delivery specification when preparing a purchase specification.
- The characteristics are the values at rated voltage (12 V, or 24V), and normal temperature and humidity.
- Max. CFM and max static pressure points conclude at max rotational speed.

General specification

Materials Used	Venturi: ABS and PBT synthetic resins Propeller: ABS and PBT synthetic resins Bearing: Both side shielded ball bearing
Motor	Brushless DC motor, Protection type: Current shut off by detecting lock state, automatically reset
Common Elec. Spec.	See pages G-11, G-12, G-13.

Standard airflow and static pressure characteristics (At rated voltage)

[By double chamber method]

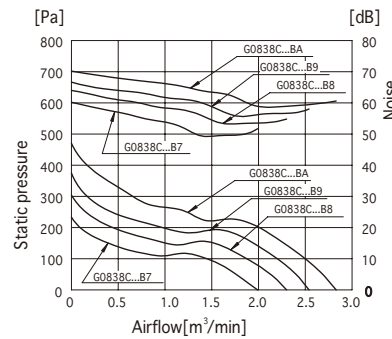

External dimensions in mm (inches)

● Lead wire type

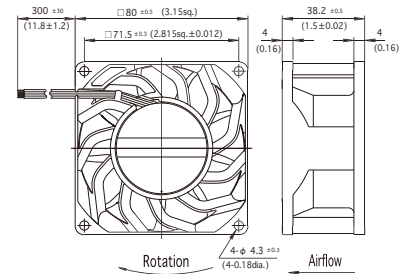

Lead wire spec. AWG24 UL3266
Color (+) Red
(-) Black
(Sensor) Yellow
(Speed control) Blue

PWM speed control specification

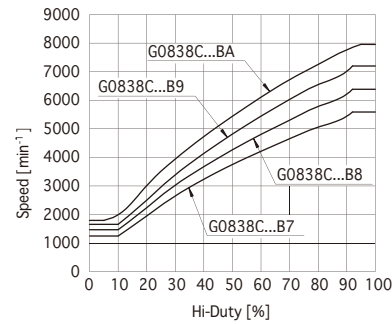

Speed performance (At rated vol., Air specification (Room temperature))

CASE 1 ·I out 1mA Max.
·V out 5V Max.
·V Losat 0.5V Max.
FREQUENCY 500kHz-5kHz

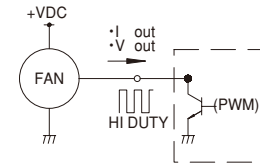

CASE 2 ·I out 1mA Max.
·I in 1mA Max.
FREQUENCY 500kHz-5kHz

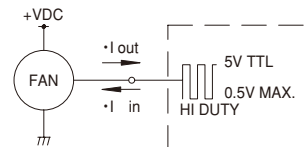

Mounting hole dimensions in mm (inches)
[Recommendation]

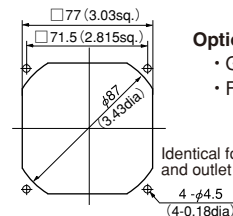

Options (sold separately)

- Guard: F80UL guard
- Filter: F80 filter

Identical for the intake and outlet sides.

- NIDEC SERVO can meet many of your requirements for customization, such as special connectors, other sensors not listed above, variable speed specifications, and other modifications. Please contact NIDEC SERVO during your product planning and development stage.
- The listed products are registered in the following overseas standards files, UL/ cUL: E48889, TUV: R50004410
- 3D data is also available at our web2-CAD site (www.web2cad.co.jp).

DC Axial Fan
Fixed Blade Type
G0938B



□ 92 × 38 (□ 3.6" × 1.5")
Max. airflow : 3.9 m³/min
Max. static pressure : 490 Pa
Mass : 320 g

Fan model code

- G0938B12B8ZP-00
- G0938B12B9ZP-00
- G0938B12BAZP-00
- G0938B24B8ZP-00
- G0938B24B9ZP-00
- G0938B24BAZP-00
- G0938B48B8ZP-00
- G0938B48B9ZP-00
- G0938B48BAZP-00

Standard specification

Max. airflow		Max. static pressure		Noise dB	Speed min ⁻¹		Voltage spec. V		Current mA		Model code	Operating Temp. Range°C
m ³ /min	CFM	Pa	inH ₂ O		Max.	Min.	Rating	Operating Range	Rating	Starting		
3.9	138	490	1.97	63	7500	2100	12	8.4-13.2	2600	4900	G0938B12BAZP-00	-20 ~ +60
							24	16.8-26.4	1300	2700	G0938B24BAZP-00	
							48	36-52.8	610	1360	G0938B48BAZP-00	
3.6	127	440	1.77	61	7000	2000	12	8.4-13.8	2000	4600	G0938B12B9ZP-00	
							24	16.8-27.6	1000	2600	G0938B24B9ZP-00	
							48	36-55.2	520	1100	G0938B48B9ZP-00	
3.2	113	350	1.41	58	6300	1600	12	8.4-13.8	1500	3800	G0938B12B8ZP-00	-20 ~ +70
							24	16.8-27.6	700	2000	G0938B24B8ZP-00	
							48	36-55.2	360	840	G0938B48B8ZP-00	

- Figures in the table are average measured values. Please request the product delivery specification when preparing a purchase specification.
- The characteristics are the values at rated voltage (12 V, 24 V, or 48 V), and normal temperature and humidity.
- Max. CFM and max static pressure points conclude at max rotational speed.

General specification

Materials Used	Venturi: Aluminum alloy die castings Propeller: ABS and PBT synthetic resins Bearing: Both side shielded ball bearing
Motor	Brushless DC motor, Protection type: Current shut off by detecting lock state, automatically reset
Common Elec. Spec.	See pages G-11, G-12, G-13.

Standard airflow and static pressure characteristics (At rated voltage)
[By double chamber method]

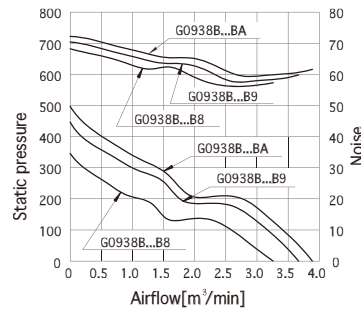

PWM speed control specification (At rated voltage)

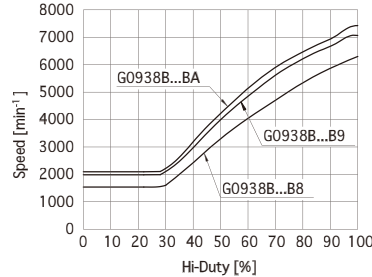

Mounting hole dimensions in mm (inches)
[Recommendation]

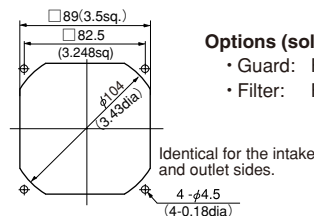

External dimensions in mm (inches)

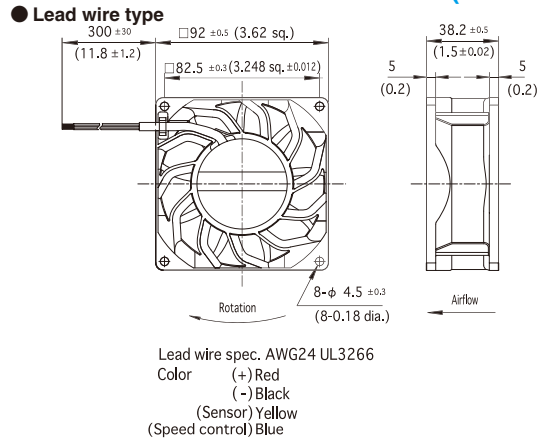

Speed performance (At rated vol., Air) specification (Room temperature)

CASE 1
 • I_{out} 1mA Max.
 • V_{out} 5V Max.
 • V_{Losat} 0.5V Max.
 FREQUENCY 500kHz-5kHz

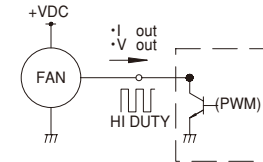

CASE 2
 • I_{out} 1mA Max.
 • I_{in} 1mA Max.
 FREQUENCY 500kHz-5kHz

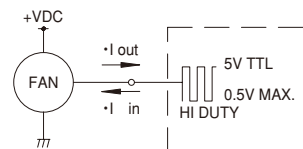

- NIDEC SERVO can meet many of your requirements for customization, such as special connectors, other sensors not listed above, variable speed specifications, and other modifications. Please contact NIDEC SERVO during your product planning and development stage.
- The listed products are registered in the following overseas standards files, UL/cUL: E48889, TUV: R50004410

DC Axial Fan
Fixed Blade Type
G1238B



□ 119 × 38 (□ 4.7" × 1.5")
Max. airflow : 7.4 m³/min
Max. static pressure : 520 Pa
Mass : 480 g

Fan model code

G1238B12BAZP-00

G1238B12BBZP-00

G1238B24BAZP-00

G1238B24BBZP-00

G1238B48BAZP-00

G1238B48BBZP-00

Standard specification

Max. airflow m ³ /min	Max. static pressure CFM	Max. static pressure Pa	Noise inH ₂ O	Noise dB	Speed min ⁻¹		Voltage spec. V		Current mA		Model code	Operating temp. range °C
					Max.	Min.	Rating	Operating Range	Rating	Starting		
7.4	261	520	2.09	67	6300	1000	12	9.6-13.8	4450	6100	G1238B12BBZP-00	-20 ~ +60
							24	16.8-27.6	2200	3100	G1238B24BBZP-00	
							48	36-55.2	1100	1600	G1238B48BBZP-00	
6.3	223	415	1.67	64	5300	1000	12	9.6-13.8	2800	3900	G1238B12BAZP-00	-20 ~ +70
							24	16.8-27.6	1300	2000	G1238B24BAZP-00	
							48	36-55.2	660	970	G1238B48BAZP-00	

- NIDEC SERVO can meet many of your requirements for customization, such as special connectors, other sensors not listed above, variable speed specifications, and other modifications. Please contact NIDEC SERVO during your product planning and development stage.
- The listed products are registered in the following overseas standards files, UL/cUL: E48889, TUV: R50004410

General specification

Materials Used	Venturi: Venturi: Aluminum alloy die castings. Propeller: ABS and PBT synthetic resins Bearing: Both side shielded ball bearing
Motor	Brushless DC motor, Protection type: Current shut off by detecting lock state, automatically reset
Common Elec. Spec.	See pages G-11, G-12, G-13.

Standard airflow and static pressure characteristics (At rated voltage)
[By double chamber method]

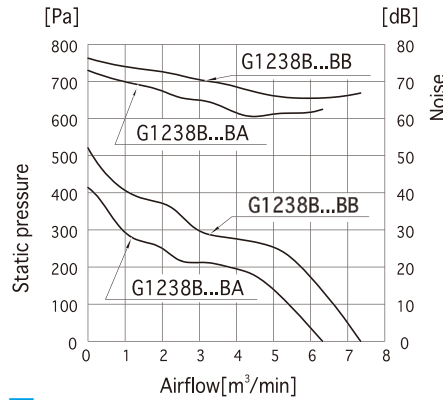

PWM speed control specification (At rated voltage)

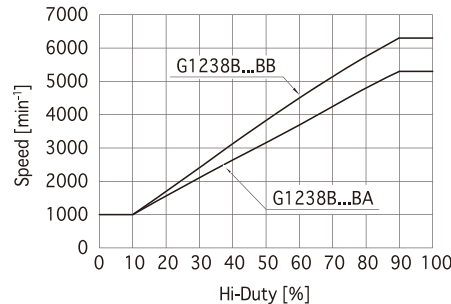

Mounting hole dimensions in mm (inches)
[Recommendation]

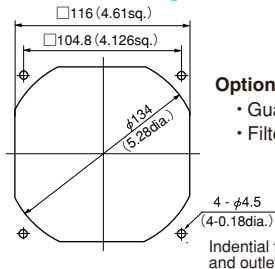

- Options (sold separately)**
- Guard: F120UL guard
 - Filter: F120 filter

Intidental for the intake and outlet sides.

- NIDEC SERVO can meet many of your requirements for customization, such as special connectors, other sensors not listed above, variable speed specifications, and other modifications. Please contact NIDEC SERVO during your product planning and development stage.
- The listed products are registered in the following overseas standards files, UL/cUL: E48889, TUV: R50004410

External dimensions in mm (inches)

● Lead wire type

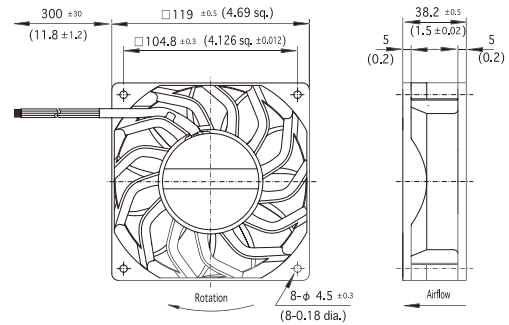

Lead wire spec. AWG22 UL3266
Color (+) Red
(-) Black
(Sensor) Yellow
(Speed control) Blue

Speed performance (At rated vol., Air) specification (Room temperature)

CASE 1

- I out 1mA Max.
- V out 5V Max.
- V Losat 0.5V Max.
- FREQUENCY 500kHz-5kHz

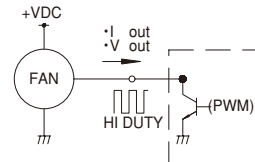

CASE 2

- I out 1mA Max.
- I in 1mA Max.
- FREQUENCY 500kHz-5kHz

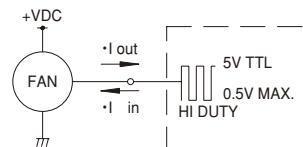

For a High Static Pressure Region
DC Axial Fan
Fixed Blade Type
G1751M



$\phi 172 \times 150 \times 51$
($\phi 6.8'' \times 6.0'' \times 2.0''$)
Max. airflow: 11.2 m³/min
Max. static pressure: 840 Pa
Mass: 820 g

Fan model code

- G1751M24B5ZP-00
- G1751M24B6ZP-00
- G1751M24B7ZP-00
- G1751M24B8ZP300
- G1751M24B9ZP300
- G1751M48B5ZP-00
- G1751M48B6ZP-00
- G1751M48B7ZP-00
- G1751M48B8ZP-00
- G1751M48B9ZP-00

High static pressure fans suitable for cooling densely assembled equipment.

Standard specification

Max. airflow		Max. static pressure		Noise	Speed min ⁻¹		Voltage spec. V		Current mA		Model code	Operating temp. range °C
m ³ /min	CFM	Pa	inH ₂ O	dB	Max.	Min.	Rating	Operating Range	Rating	Starting		
11.2	395	780	3.13	74(7.9m ³ /min)	6800	3200	24	16-28	4800	6900	G1751M24B9ZP300	-20 ~ +60
		840	3.37				48	36-60	2500	6000	G1751M48B9ZP-00	
10	353	710	2.85	71(9m ³ /min)	6200	2600	24	16-28	3600	5100	G1751M24B8ZP300	
							48	36-60	1800	3500	G1751M48B8ZP-00	
9.2	325	580	2.33	69(6.7m ³ /min)	5600	2000	24	12-27.6	2850	6100	G1751M24B7ZP-00	
							48	36-60	1360	2650	G1751M48B7ZP-00	
8.3	293	490	1.97	66.5(6.1m ³ /min)	5100	1500	24	12-27.6	2250	3800	G1751M24B6ZP-00	
							48	36-60	1040	2100	G1751M48B6ZP-00	
7.3	258	360	1.45	63(5.3m ³ /min)	4500	1500	24	12-27.6	1500	2800	G1751M24B5ZP-00	
							48	36-60	700	1400	G1751M48B5ZP-00	

- Figures in the table are average measured values. Please request the product delivery specification when preparing a purchase specification.
- The characteristics are the values at rated voltage (12 V), and normal temperature and humidity.
- Max. CFM and max static pressure points conclude at max rotational speed.

General specification

Materials Used	Venturi: Aluminum alloy die castings Propeller: ABS and PBT synthetic resins Bearing: Both side shielded ball bearing
Motor	Brushless DC motor, Protection type: Overcurrent detection and automatic resetting by current limiting
Common Elec. Spec.	See pages G-11, G-12, G-13.
Standard Carton	12 to a carton of (450 x 380 x 220) mm, mass 11 kg

Standard airflow and static pressure characteristics (At rated voltage)
[By double chamber method]

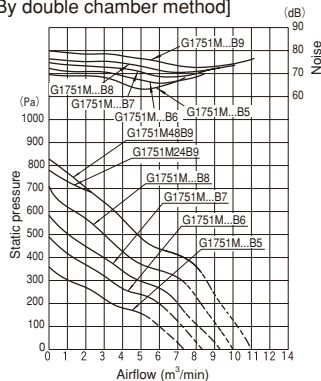

External dimensions in mm (inches)

● Lead wire type

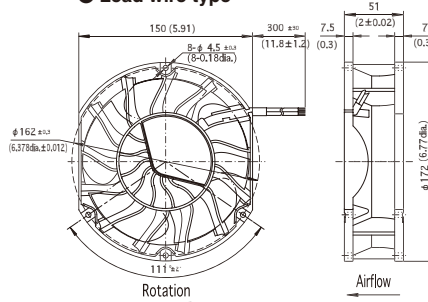

Lead wire spec. AWG24 UL3266
Color (+) Red (-) Black (Sensor) Yellow (Speed control) Blue

PWM speed control specification

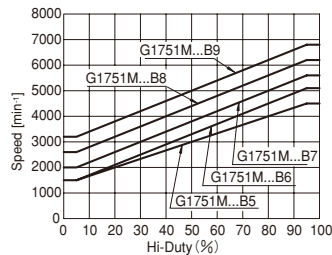

Speed performance (At rated vol., Air specification (Room temperature))

CASE 1
· I out 1mA Max.
· V out 5V Max.
· V Losat 0.5V Max.
FREQUENCY 500kHz-5kHz

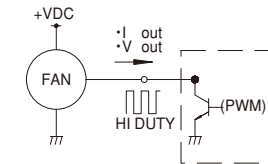

CASE 2
· I out 1mA Max.
· I in 1mA Max.
FREQUENCY 500kHz-5kHz

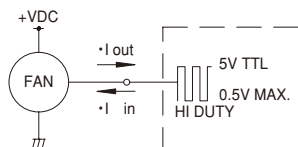

Mounting hole dimensions in mm (inches)
[Recommendation]

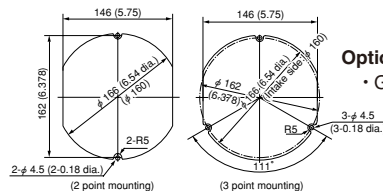

Options (sold separately)
· Guard: GUARD172

- NIDEC SERVO can meet many of your requirements for customization, such as special connectors, other sensors not listed above, variable speed specifications, and other modifications. Please contact NIDEC SERVO during your product planning and development stage.
- The listed products are registered in the following overseas standards files, UL/cUL: E48889, TUV: R50004410

Fans & Blowers

Axial

DC fans

Centrifugal

Silent

AC fans

Axial

Centrifugal

Option

Super Silent Blowers

E0525H/K



□48×25 (□1.9"×1.0")
Max. airflow: 0.22 m³/min
Max. static pressure: 220 Pa
Mass: 50 g

■ Features

- The smaller 48 mm square blower gives as much airflow output as a larger 70 mm square blower while maintaining the same low noise level.
- Both clockwise and counterclockwise discharge (mirror-image) versions are available.

Fan model code

- E0525H12B7AP-00
- E0525H12B7AS-00
- E0525H12B7AZ-00
- E0525H24B7AZ-00
- E0525K12B7AP-00
- E0525K12B7AS-00
- E0525K12B7AZ-00
- E0525K24B7AZ-00

■ Standard specification

Max. Airflow m ³ /min	Max. Static Pressure CFM	Max. Static Pressure		Noise dB	Speed min ⁻¹	Voltage Spec. V		Current mA		Model Code	Operating Temp. Range °C
		Pa	inH ₂ O			Rating	Operating Range	Rating	Starting		
0.22	7.8	220	0.88	42.5	6700	12	4.5-13.8	230	530	E0525H12B7AZ-00	-20 ~ +70
										E0525K12B7AZ-00	
						24	9.6-27.6	110	280	E0525H24B7AZ-00	
										E0525K24B7AZ-00	

- Figures in the table are average measured values. Please request the product delivery specification when preparing a purchase specification.
- The characteristics are the values at rated voltage (12 V or 24 V), and normal temperature and humidity.

■ General specification

Materials Used	Venturi: ABS and PBT synthetic resins Impeller: ABS and PBT synthetic resins Bearing: Both side shielded ball bearing
Motor	Brushless DC motor, Protection type: Current shut off by detecting lock state, automatically reset
Common Elec. Spec.	See pages G-11, G-12, G-13.

■ Standard airflow and static pressure characteristics (At rated voltage)

[By double chamber method]

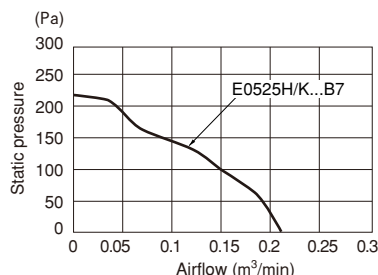

■ External dimensions in mm (inches)

● Lead wire type (E0525H)

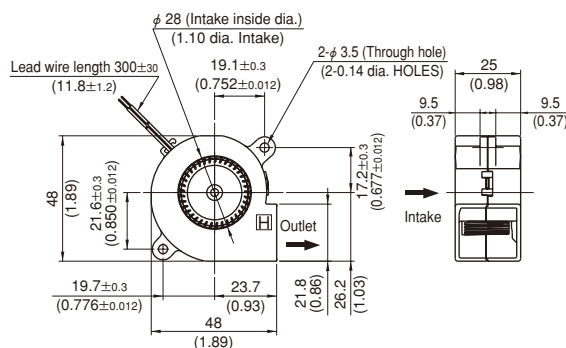

Lead wire spec. AWG26 UL3265
Color (+) Red
(-) Black

■ Wiring connection diagram

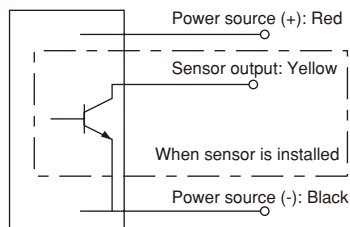

● Lead wire type (E0525K)

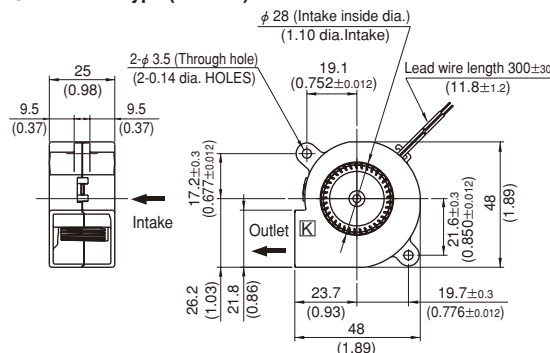

Lead wire spec. AWG26 UL3265
Color (+) Red
(-) Black

Super silent blower with sensor

Rated Vol.	Model Code
12 V	E0525H12B7AS-00
	E0525K12B7AS-00
	E0525H12B7AP-00
	E0525K12B7AP-00

- NIDEC SERVO can meet many of your requirements for customization, such as special connectors, other sensors not listed above and other modifications. Please contact NIDEC SERVO during your product planning and development stage.
- The listed products are registered in the following overseas standards files, UL: cUL E48889, TUV: R50004410

DC Centrifugal
Blowers

E0515H



51×53×15

(2.0"×2.1"×0.6")

Max. airflow: 0.125 m³/min

Max. static pressure: 210 Pa

Mass: 30 g

Fan model code

E0515H12B3AZ-00

E0515H12B5AS-00

E0515H12B5AZ-00

E0515H12B7APA01

E0515H12B7ASA01

E0515H12B7AZA01

E0515H12B8APA01

E0515H12B8ASA01

E0515H12B8AZA01

E0515H24B5AP-01

E0515H24B5AS-01

E0515H24B5AZ-00

E0515H24B7APA01

E0515H24B7AZA01

E0515H24B8ASA01

E0515H24B8AZA01

Standard specification

Max. Airflow m ³ /min	Max. Static Pressure CFM	Max. Static Pressure Pa	Noise inH ₂ O	Noise dB	Speed min ⁻¹	Input W	Voltage Spec. V		Current mA		Model Code	Operating Temp. Range °C
							Rating	Operating Range	Rating	Starting		
0.125	4.4	210	0.84	42	6100	2.3	12	6-13.8	190	320	E0515H12B8AZA01	-20 ~ +60
						2.4	24	12-27.6	100	160	E0515H24B8AZA01	
0.11	3.9	165	0.66	40	5500	1.7	12	6-13.8	140	225	E0515H12B7AZA01	-20 ~ +80
						1.9	24	12-27.6	80	130	E0515H24B7AZA01	
0.1	3.5	135	0.54	37	5000	1.4	12	9.6-13.8	120	190	E0515H12B5AZ-00	-20 ~ +60
						1.4	24	16.8-27.6	60	110	E0515H24B5AZ-00	
0.09	3.2	110	0.44	34	4500	1.1	12	9.6-13.8	90	150	E0515H12B3AZ-00	

- Figures in the table are average measured values. Please request the product delivery specification when preparing a purchase specification.
- The characteristics are the values at rated voltage (12 V or 24 V), and normal temperature and humidity.
- The life expectancy of E0515H-8 speed products at rated voltage and in continuous operation is 20,000 hours at 60°C. (30,000 hours for other products)

General specification

Materials Used	Venturi: ABS and PBT synthetic resins Impeller: ABS and PBT synthetic resins Bearing: Both side shielded ball bearing
Motor	Brushless DC motor, Protection type: Current shut off by detecting lock state, automatically reset
Common Elec. Spec.	See pages G-11, G-12, G-13.

Standard airflow and static pressure characteristics (At rated voltage)

[By double chamber method]

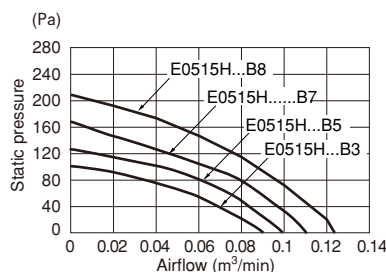

External dimensions in mm (inches)

Lead wire type

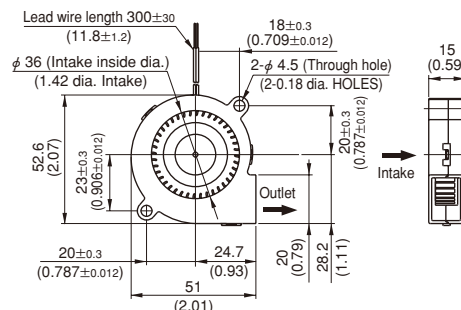

Lead wire spec. UL1061 AWG26 or UL3265 AWG26
Color (+) Red
(-) Black

Wiring connection diagram

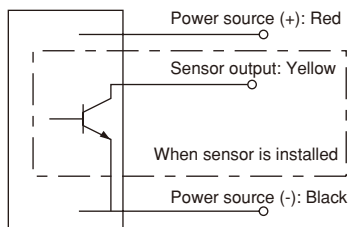

DC centrifugal blower with sensor

Rated Vol.	Model Code		
12 V	E0515H12B5AS-00	E0515H12B7ASA01	E0515H12B8ASA01
		E0515H12B7APA01	E0515H12B8APA01
24 V	E0515H24B5AS-00		E0515H24B8ASA01
	E0515H24B5AP-00	E0515H24B7APA01	

- NIDEC SERVO can meet many of your requirements for customization, such as special connectors, other sensors not listed above and other modifications. Please contact NIDEC SERVO during your product planning and development stage.
- The listed products are registered in the following overseas standards files, UL: E48889, CSA: LR49399, TUV: R9451586
- 3D data is also available at our web2-CAD site (www.cadenas.co.jp).

Super Silent Blowers

E0720H



70×76×20
(2.8"×3.0"×0.8")
Max. airflow: 0.29 m³/min
Max. static pressure: 300 Pa
Mass: 50 g

Fan model code

- E0720H12B5AP-00
- E0720H12B5AS-00
- E0720H12B5AZ-00
- E0720H12B7AP-00
- E0720H12B7AS-00
- E0720H12B7AZ-00
- E0720H12B7CZ-00
- E0720H12B8AP-00
- E0720H12B8AS-00
- E0720H12B8AZ-00
- E0720H24B5AP-00
- E0720H24B5AZ-00
- E0720H24B7AZ-00
- E0720H24B8AP-00
- E0720H24B8AS-00
- E0720H24B8AZ-00

Standard specification

Max. Airflow		Max. Static Pressure		Noise dB	Speed min ⁻¹	Voltage Spec. V		Current mA		Model Code	Operating Temp. Range °C
m ³ /min	CFM	Pa	inH ₂ O			Rating	Operating Range	Rating	Starting		
0.29	10.2	300	1.21	44	4750	12	5-13.8	300	580	E0720H12B8AZ-00	-20 ~ +70
						24	10-27.6	140	270	E0720H24B8AZ-00	
0.27	9.5	250	1.01	42	4400	12	5-13.8	240	480	E0720H12B7AZ-00	
						24	10-27.6	120	240	E0720H24B7AZ-00	
0.25	8.8	210	0.84	40	4050	12	5.5-13.8	200	390	E0720H12B5AZ-00	
						24	10-27.6	100	200	E0720H24B5AZ-00	

- Figures in the table are average measured values. Please request the product delivery specification when preparing a purchase specification.
- The characteristics are the values at rated voltage (12 V or 24 V), and normal temperature and humidity.
- Life expectancy of the E0720H-8 series in continuous operation at rated voltage is 20,000 hours at an operating temperature of 60°C. (25,000 hours for other products)

General specification

Materials Used	Venturi: ABS and PBT synthetic resins Impeller: ABS and PBT synthetic resins Bearing: Both side shielded ball bearing
Motor	Brushless DC motor, Protection type: Current shut off by detecting lock state, automatically reset
Common Elec. Spec.	See pages G-11, G-12, G-13.
Standard Carton	150 to a carton of (450 x 380 x 295) mm, mass 8 kg

Standard airflow and static pressure characteristics (At rated voltage)

[By double chamber method]

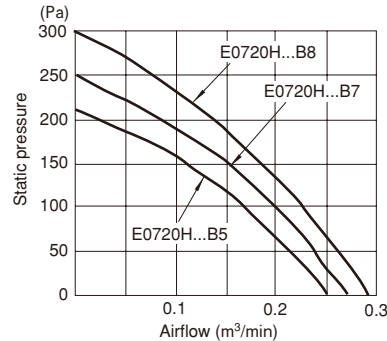

External dimensions in mm (inches)

● Lead wire type

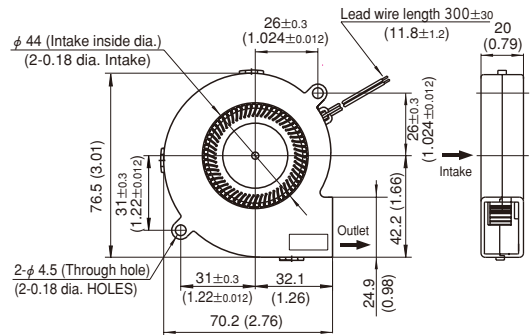

Lead wire spec. AWG26 UL3265
Color (+) Red
(-) Black

Wiring connection diagram

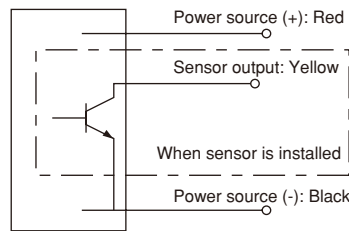

Super silent blower with sensor

Rated Vol.	Model Code		
12 V	E0720H12B5AS-00	E0720H12B7AS-00	E0720H12B8AS-00
	E0720H12B5AP-00	E0720H12B7AP-00	E0720H12B8AP-00
24 V	E0720H24B5AP-00		E0720H24B8AS-00
			E0720H24B8AP-00

- NIDEC SERVO can meet many of your requirements for customization, such as special connectors, other sensors not listed above, variable speed specifications, and other modifications. Please contact NIDEC SERVO during your product planning and development stage.
- The listed products are registered in the following overseas standards files, UL: E48889, CSA: LR49399, TUV: R50004410

Super Silent Blowers

E0720L



72×75×20

(2.8"×3.0"×0.8")

Max. airflow: 0.31 m³/min

Max. static pressure: 265 Pa

Mass: 50 g

Features

- Dimensions almost equivalent to those of E0720H, yet features higher airflow and lower noise.
- Suitable for equipment that prioritizes high airflow over high static pressure.

Fan model code

E0720L12B5AZ-00

E0720L12B7AZ-00

E0720L12B8AP-00

E0720L12B8AS-00

E0720L12B8AZ-00

E0720L12B8CZ-00

Standard specification

Max. Airflow		Max. Static Pressure		Noise dB	Speed min ⁻¹	Voltage Spec. V		Current mA		Model Code	Operating Temp. Range °C	
m³/min	CFM	Pa	inH ₂ O			Rating	Operating Range	Rating	Starting			
0.31	10.9	265	1.07	41	4200	12	4.5-12.8	300	620	E0720L12B8AZ-00	-20 ~ +70	
0.30	10.6	245	0.98	40.5	4050		4.5-13.8	260	520			E0720L12B7AZ-00
0.27	9.5	190	0.76	38	3700		4.5-13.8	190	390			E0720L12B5AZ-00

- Figures in the table are average measured values. Please request the product delivery specification when preparing a purchase specification.
- The characteristics are the values at rated voltage (12 V), and normal temperature and humidity.
- The life expectancy of E0720L-8 speed products at rated voltage and in continuous operation is 18,000 hours at 60 °C. (25,000 hours for other products)

General specification

Materials Used	Venturi: ABS and PBT synthetic resins Impeller: ABS and PBT synthetic resins Bearing: Both side shielded ball bearing
Motor	Brushless DC motor, Protection type: Current shut off by detecting lock state, automatically reset
Common Elec. Spec.	See pages G-11, G-12, G-13.
Standard Carton	150 to a carton of (450 x 380 x 295) mm, mass 8 kg

Standard airflow and static pressure characteristics (At rated voltage)

[By double chamber method]

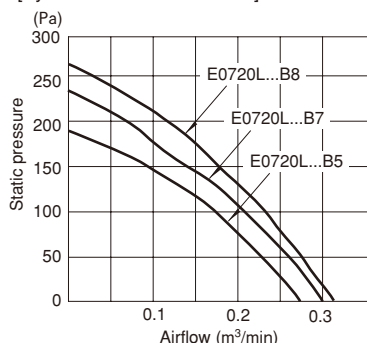

External dimensions in mm (inches)

Lead wire type

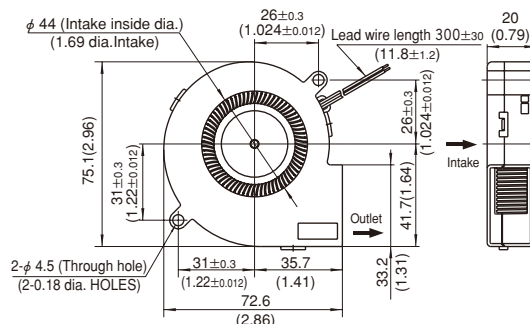

Lead wire spec. AWG26 UL3265
Color (+) Red
(-) Black

Wiring connection diagram

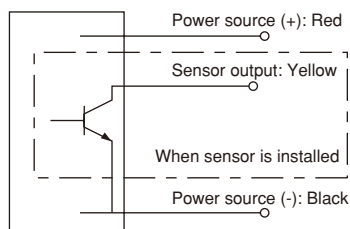

Super silent blower with sensor

Rated Vol.	Model Code
12 V	E0720L12B8AS-00
	E0720L12B8AP-00

- NIDEC SERVO can meet many of your requirements for customization, such as special connectors, other sensors not listed above, variable speed specifications, and other modifications. Please contact NIDEC SERVO during your product planning and development stage.
- The listed products are registered in the following overseas standards files, UL/cUL: E48889, TUV: R50004410

DC Centrifugal
Blowers
SMBD



□ 76 × 25 (□ 3.0" × 1.0")
Max. airflow: 0.33 m³/min
Max. static pressure: 180 Pa
Mass: 95 g

Fan model code

SMBD12B4

SMBD12H4

SMBD12H4C

SMBD12H4P

SMBD12H4S

SMBD12Z4

SMBD12Z4S

SMBD24B4

SMBD24B4S

SMBD24H4

SMBD24H4P

SMBD24H4S

SMBD24Z4

SMBD24Z4P

SMBD24Z4S

Standard specification

Max. Airflow		Max. Static Pressure		Noise dB	Speed min ⁻¹	Input W	Voltage Spec. V		Current mA		Model Code	Operating Temp. Range °C
m ³ /min	CFM	Pa	inH ₂ O				Rating	Operating Range	Rating	Starting		
0.33	11.6	180	0.72	48	4500	4.0	12	7.2-13.8	330	820	SMBD12H4	-20 ~ +60
						4.4	24	12-27.6	190	440	SMBD24H4	
0.27	9.5	118	0.47	43	3800	2.7	12	7.2-13.8	230	550	SMBD12Z4	
							24	12-27.6	120	350	SMBD24Z4	
0.24	8.5	88	0.35	41	3400	2.2	12	7.2-13.8	180	450	SMBD12B4	
							24	12-27.6	90	250	SMBD24B4	

- Figures in the table are average measured values. Please request the product delivery specification when preparing a purchase specification.
- The characteristics are the values at rated voltage (12 V or 24 V), and normal temperature and humidity.

General specification

Materials Used	Venturi: ABS and PBT synthetic resins Impeller: ABS and PBT synthetic resins Bearing: Both side shielded ball bearing
Motor	Brushless DC motor, Protection type: Current shut off by detecting lock state, automatically reset
Common Elec. Spec.	See pages G-11, G-12, G-13.
Standard Carton	120 to a carton of (450 x 380 x 300) mm, mass 9 kg

Standard airflow and static pressure characteristics (At rated voltage)

[By double chamber method]

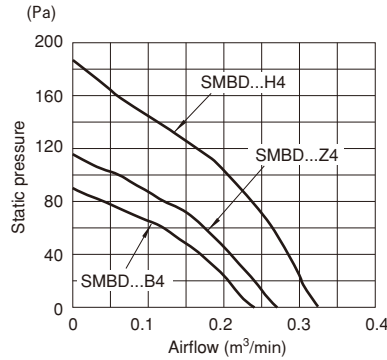

Wiring connection diagram

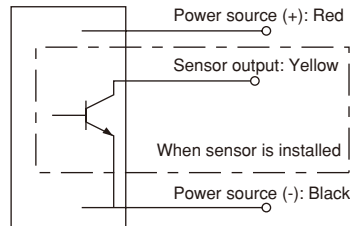

DC centrifugal blower with sensor

Rated Vol.	Model Code		
12 V		SMBD12Z4S	SMBD12H4S SMBD12H4P
24 V	SMBD24B4S	SMBD24Z4S SMBD24Z4P	SMBD24H4S SMBD24H4P

- NIDEC SERVO can meet many of your requirements for customization, such as special connectors, other sensors not listed above, variable speed specifications, and other modifications. Please contact NIDEC SERVO during your product planning and development stage.
- The listed products are registered in the following overseas standards files, UL: E48889, CSA: LR49399, TUV: R9451586
- 3D data is also available at our web2-CAD site (www.cadenas.jp).

External dimensions in mm (inches)

● Lead wire type

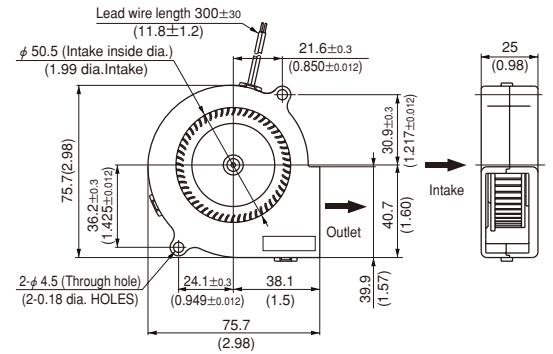

Lead wire spec. AWG24 UL1007 or UL3266
Color (+) Red
(-) Black

DC Centrifugal
Blowers
MBDC



□76×30 (□3.0"×1.2")
Max. airflow: 0.33 m³/min
Max. static pressure: 172 Pa
Mass: 105 g

Fan model code

- MBDC12B4
- MBDC12H4
- MBDC12H4S
- MBDC12Z4
- MBDC12Z4S
- MBDC24B4
- MBDC24B4S
- MBDC24Z4

■ Standard specification

Max. Airflow m ³ /min	Max. Static Pressure CFM	Noise Pa	Speed inH ₂ O	Noise dB	Speed min ⁻¹	Input W	Voltage Spec. V		Current mA		Model Code	Operating Temp. Range °C
							Rating	Operating Range	Rating	Starting		
0.33	11.6	172	0.69	47	4200	4.6	12	7.2-13.8	380	820	MBDC12H4	-20 ~ +60
							12	7.2-13.8	250	600	MBDC12Z4	
0.29	10.2	117	0.47	41	3400	3.1	24	12-27.6	140	300	MBDC24Z4	
							12	7.2-13.8	200	450	MBDC12B4	
0.25	8.8	83	0.33	38	3000	2.5	24	12-27.6	110	250	MBDC24B4	

- Figures in the table are average measured values. Please request the product delivery specification when preparing a purchase specification.
- The characteristics are the values at rated voltage (12 V or 24 V), and normal temperature and humidity.

■ General specification

Materials Used	Venturi: ABS and PBT synthetic resins Impeller: ABS and PBT synthetic resins Bearing: Both side shielded ball bearing
Motor	Brushless DC motor, Protection type: Current shut off by detecting lock state, automatically reset
Common Elec. Spec.	See pages G-11, G-12, G-13.
Standard Carton	120 to a carton of (450 x 380 x 300) mm, mass 13 kg

■ Standard airflow and static pressure characteristics (At rated voltage)

[By double chamber method]

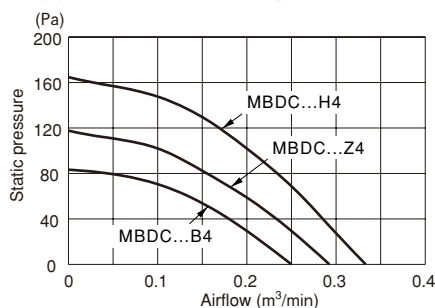

■ External dimensions in mm (inches)

● Lead wire type

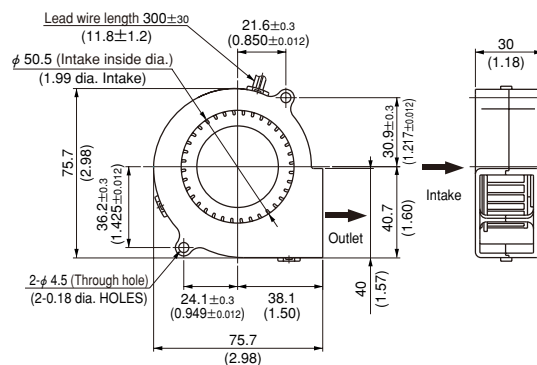

Lead wire spec. AWG24 UL1007 or UL3266
Color (+) Red
(-) Black

■ Wiring connection diagram

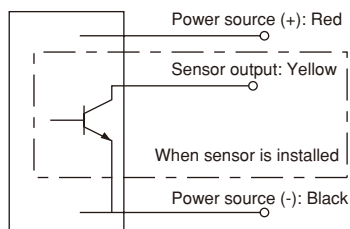

DC centrifugal blower with sensor

Rated Vol.	Model Code	
12 V	MBDC12Z4S	MBDC12H4S
24 V	MBDC24B4S	

- NIDEC SERVO can meet many of your requirements for customization, such as special connectors, other sensors not listed above, variable speed specifications, and other modifications. Please contact NIDEC SERVO during your product planning and development stage.
- The listed products are registered in the following overseas standards files, UL: E48889, CSA: LR49399, TUV: R9451586
- Customizing to the sleeve bearing specification also accepted depending on the intended purchase quantity. Contact NIDEC SERVO for further information.
- 3D data is also available at our web2-CAD site (www.cadenas.co.jp).

Super Silent Blowers

E0818K



□ 87 × 18 (□ 3.4" × 0.7")
Max. airflow: 0.28 m³/min
Max. static pressure: 285 Pa
Mass: 60 g

Fan model code

E0818K12B5AP-00

E0818K12B5AS-00

E0818K12B5AZ-00

E0818K12B6AP-00

E0818K12B6AS-00

E0818K12B6AZ-00

Standard specification

Max. Airflow		Max. Static Pressure		Noise	Speed	Voltage Spec. V		Current mA		Model Code	Operating Temp. Range °C
m ³ /min	CFM	Pa	inH ₂ O	dB	min ⁻¹	Rating	Operating Range	Rating	Starting		
0.28	9.9	285	1.14	41	3400	12	4.5-13.2	280	580	E0818K12B6AZ-00	-20 ~ +70
0.26	9.2	240	0.96	38	3100	12	4.5-13.2	210	410	E0818K12B5AZ-00	

- Figures in the table are average measured values. Please request the product delivery specification when preparing a purchase specification.
- The characteristics are the values at rated voltage (12 V), and normal temperature and humidity.

General specification

Materials Used	Venturi: ABS and PBT synthetic resins Impeller: ABS and PBT synthetic resins Bearing: Both side shielded ball bearing
Motor	Brushless DC motor, Protection type: Current shut off by detecting lock state, automatically reset
Common Elec. Spec.	See pages G-11, G-12, G-13.

Standard airflow and static pressure characteristics (At rated voltage)

[By double chamber method]

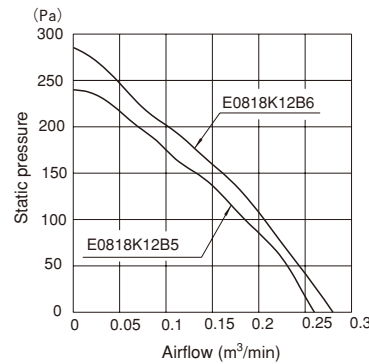

External dimensions in mm (inches)

● Lead wire type

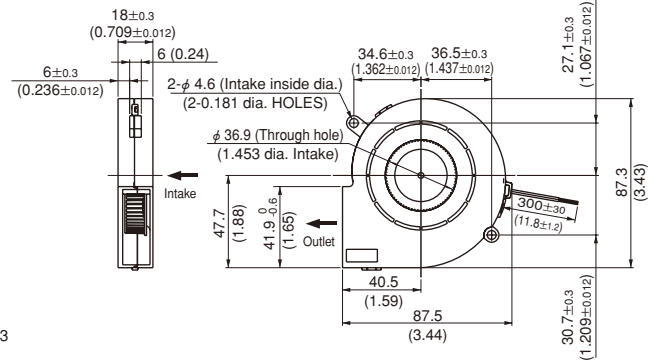

Lead wire spec. AWG26 UL3265
Color (+) Red
(-) Black

Wiring connection diagram

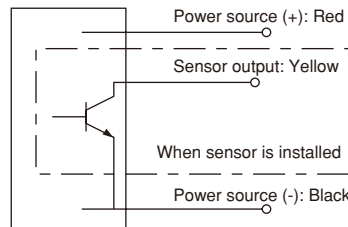

Super silent blower with sensor

Rated Vol.	Model Code	
12 V	E0818K12B5AS-00	E0818K12B6AS-00
	E0818K12B5AP-00	E0818K12B6AP-00

- NIDEC SERVO can meet many of your requirements for customization, such as special connectors, other sensors not listed above, variable speed specifications, and other modifications. Please contact NIDEC SERVO during your product planning and development stage.
- The listed products are registered in the following overseas standards files, UL/cUL: E48889, TUV: R50004410

DC Centrifugal
Blowers
SFBD



□ 94 × 30 (□ 3.7" × 1.2")
Max. airflow: 0.65 m³/min
Max. static pressure: 280 Pa
Mass: 135 g

Fan model code

- SFBD12B4
- SFBD12H7
- SFBD12Z7
- SFBD12Z7P
- SFBD24B4
- SFBD24H7
- SFBD24H7C
- SFBD24H7S
- SFBD24Z7
- SFBD24Z7P
- SFBD24Z7S

Standard specification

Max. Airflow m ³ /min	Max. Static Pressure CFM	Noise Pa	Speed inH ₂ O	Noise dB	Speed min ⁻¹	Input W	Voltage Spec. V		Current mA		Model Code	Operating Temp. Range °C
							Rating	Operating Range	Rating	Starting		
0.65	23	280	1.13	53	3900	7.8	12	7.2-13.8	650	1600	SFBD12H7	-20 ~ +60
						7.9	24	12-27.6	330	810	SFBD24H7	
0.56	20	200	0.80	49	3300	5.0	12	7.2-13.8	440	1120	SFBD12Z7	
						5.5	24	12-27.6	300	600	SFBD24Z7	
0.44	16	120	0.48	45	2700	3.5	12	7.2-13.8	290	630	SFBD12B4	
						24	12-27.6	150	330	SFBD24B4		

- Figures in the table are average measured values. Please request the product delivery specification when preparing a purchase specification.
- The characteristics are the values at rated voltage (12 V or 24 V), and normal temperature and humidity.
- The life expectancy of SFBD-H speed products at rated voltage and in continuous operation is 30,000 hours at 60 °C. (40,000 hours for other products)

General specification

Materials Used	Venturi: ABS and PBT synthetic resins Impeller: ABS and PBT synthetic resins Bearing: Both side shielded ball bearing
Motor	Brushless DC motor, Protection type: Current shut off by detecting lock state, automatically reset
Common Elec. Spec.	See pages G-11, G-12, G-13.
Standard Carton	60 to a carton of (450 x 380 x 220) mm, mass 9 kg

Standard airflow and static pressure characteristics (At rated voltage)

[By double chamber method]

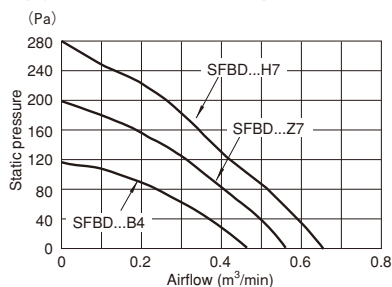

External dimensions in mm (inches)

● Lead wire type

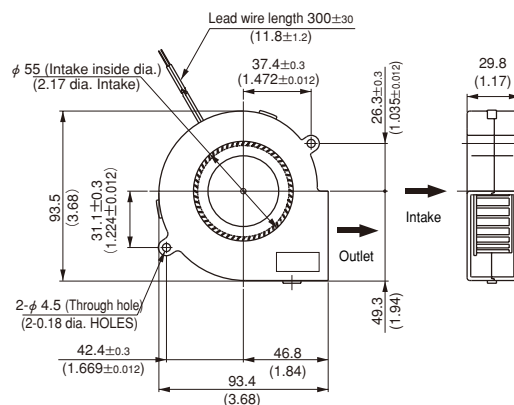

Lead wire spec. AWG24 UL1007 or UL3266
Color (+) Red
(-) Black

Wiring connection diagram

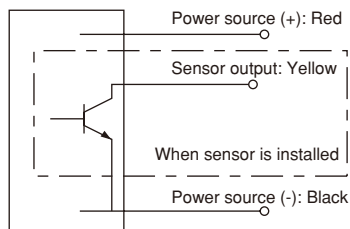

DC centrifugal blower with sensor

Rated Vol.	Model Code	
12 V	SFBD12Z7P	
24 V	SFBD24Z7S	SFBD24H7S
	SFBD24Z7P	

- NIDEC SERVO can meet many of your requirements for customization, such as special connectors, other sensors not listed above, variable speed specifications, and other modifications. Please contact NIDEC SERVO during your product planning and development stage.
- The listed products are registered in the following overseas standards files, UL: E48889, CSA: LR49399, TUV: R9451586
- Customizing to the sleeve bearing specification also accepted depending on the intended purchase quantity. Contact NIDEC SERVO for further information.
- 3D data is also available at our web2-CAD site (www.cadenas.co.jp).

Fans & Blowers

Axial

DC fans

Centrifugal

Silent

AC fans

Axial

Centrifugal

Option

Super Silent Blowers

E1027H



97×95×25
(3.8"×3.7"×1.0")
Max. airflow: 0.78 m³/min
Max. static pressure: 520 Pa
Mass: 125 g (~7), 150 g (~A)

Fan model code

E1027H12B7AP-00

E1027H12B7AS-00

E1027H12B7AZ-00

E1027H12BAAP-00

E1027H12BAAS-00

E1027H12BAAZ-00

Standard specification

Max. Airflow		Max. Static Pressure		Noise	Speed	Voltage Spec. V		Current mA		Model Code	Operating Temp. Range °C
m ³ /min	CFM	Pa	inH ₂ O	dB	min ⁻¹	Rating	Operating Range	Rating	Starting		
0.78	28	520	2.09	55	5000	12	8.4-13.8	1000	2200	E1027H12BAAZ-00	-20 ~ +60
0.57	20	315	1.27	47	3600		5.0-13.2	550	1670	E1027H12B7AZ-00	-20 ~ +70

- Figures in the table are average measured values. Please request the product delivery specification when preparing a purchase specification.
- The characteristics are the values at rated voltage (12 V), and normal temperature and humidity.

General specification

Materials Used	Venturi: ABS and PBT synthetic resins Impeller: ABS and PBT synthetic resins Bearing: Both side shielded ball bearing
Motor	Brushless DC motor, Protection type: Current shut off by detecting lock state, automatically reset
Common Elec. Spec.	See pages G-11, G-12, G-13.

Standard airflow and static pressure characteristics (At rated voltage)

[By double chamber method]

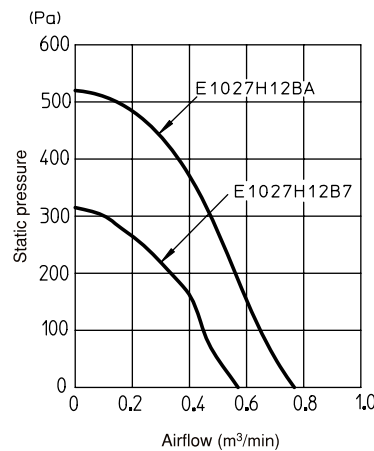

External dimensions in mm (inches)

● Lead wire type

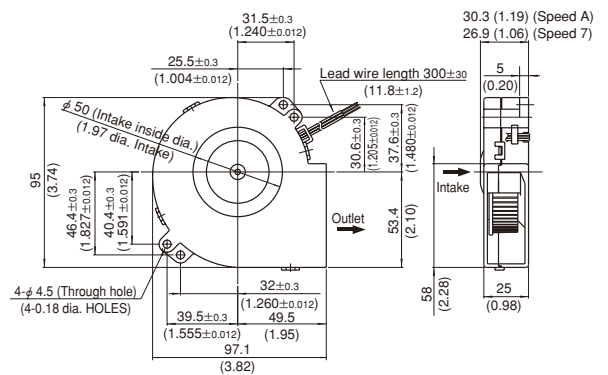

Lead wire spec. AWG24 UL3266
Color (+) Red
(-) Black

Wiring connection diagram

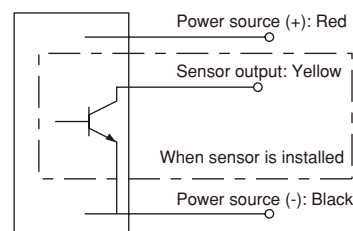

Super silent blower with sensor

Rated Vol.	Model Code	
12 V	E1027H12B7AS-00	E1027H12BAAS-00
	E1027H12B7AP-00	E1027H12BAAP-00

- NIDEC SERVO can meet many of your requirements for customization, such as special connectors, other sensors not listed above, variable speed specifications, and other modifications. Please contact NIDEC SERVO during your product planning and development stage.
- The listed products are registered in the following overseas standards files, UL/cUL: E48889, TUV: R50004410

Super Silent Blowers

E1033H/Y



97×95×33
(3.8"×3.7"×1.3")
Max. airflow: 1.30 m³/min
Max. static pressure: 800 Pa
Mass: 140 g (~B), 160 g (~A), 170 g (~C)

Fan model code

E1033H12B5AM-04

E1033H12B6AM-04

E1033H12B7AP-00

E1033H12B7AS-00

E1033H12B7AZ-00

E1033H12B8AP-00

E1033H12B8AS-00

E1033H12B8AZ-00

E1033H12BAAP-00

E1033H12BAAS-00

E1033H12BAAZ-00

E1033H24B5AM-04

E1033H24B6AM-04

E1033H24B6AP-00

E1033H24B6AS-00

E1033H24B6AZ-00

E1033H24B7AS-00

E1033H24B7AS-00

E1033H24B7AZ-00

E1033H24B8AP-00

E1033H24B8AS-00

E1033H24B8AZ-00

E1033H24BAAP-00

E1033H24BAAS-00

E1033H24BAAZ-00

E1033Y12BBAP-00

E1033Y12BBAS-00

E1033Y12BBAZ-00

E1033Y12BCAP-00

E1033Y12BCAS-00

E1033Y12BCAZ-00

E1033Y24BBAP-00

E1033Y24BBAS-00

E1033Y24BBAZ-00

E1033Y24BCAP-00

E1033Y24BCAS-00

E1033Y24BCAZ-00

Standard specification

Max. Airflow m ³ /min	Max. Static Pressure CFM	Pa	inH ₂ O	Noise dB	Speed min ⁻¹	Voltage spec. V		Current mA		Model Code	Operating Temp. Range °C	
						Rating	Operating Range	Rating	Starting			
1.30	46	800	3.22	62	5800	12	8.4-13.2	1850	3430	E1033Y12BCAZ-00	-20 ~ +60	
						24	12-26.4	900	2830	E1033Y24BCAZ-00		
1.19	42	630	2.53	60	5300	12	8.4-13.2	1450	3100	E1033Y12BBAZ-00		
						24	12-26.4	710	2700	E1033Y24BBAZ-00		
1.14	40	500	2.01	58	4850	12	8.4-13.2	1250	2100	E1033H12BAAZ-00		
						24	16-26.4	630	1850	E1033H24BAAZ-00		
0.85	30	320	1.29	51	3450	12	4.5-13.2	770	1950	E1033H12B8AZ-00		-20 ~ +70
						24	10-26.4	390	940	E1033H24B8AZ-00		
0.76	27	260	1.05	48	3100	12	5-13.2	590	1260	E1033H12B7AZ-00		
						24	10-26.4	300	710	E1033H24B7AZ-00		
0.64	23	185	0.74	43	2600	12	5-13.2	400	820	E1033H12B6AM-04		
						24	10-26.4	220	400	E1033H24B6AZ-00		
0.53	19	120	0.48	39	2200	12	5-13.8	250	500	E1033H12B5AM-04		
						24	10-26.4	120	260	E1033H24B5AM-04		

- Figures in the table are average measured values. Please request the product delivery specification when preparing a purchase specification.
- The characteristics are the values at rated voltage (12 V or 24 V), and normal temperature and humidity.

General specification

Materials Used	Venturi: ABS and PBT synthetic resins Impeller: ABS and PBT synthetic resins Bearing: Both side shielded ball bearing
Motor	Brushless DC motor, Protection type: Current shut off by detecting lock state, automatically reset
Common Elec. Spec.	See pages G-11, G-12, G-13.
Standard Carton	50 to a carton of (450 x 380 x 220) mm, mass 8 kg

Standard airflow and static pressure characteristics (At rated voltage)

[By double chamber method]

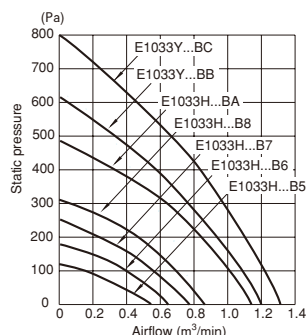

Wiring connection diagram

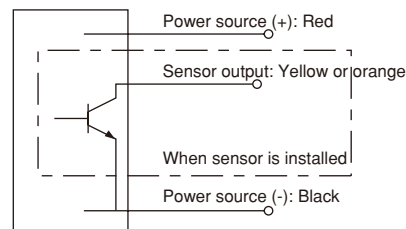

External dimensions in mm (inches)

Lead wire type (E1033H/Y)

Lead wire spec. AWG24 UL3266
Color (+) Red
(-) Black

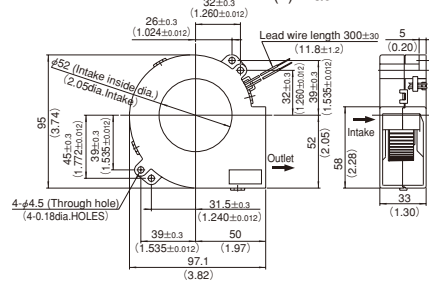

Terminal type (E1033H□□B□AM-04)

(Note: Multi-sensor products with lock detection or pulse output, depending on the connection cord.)

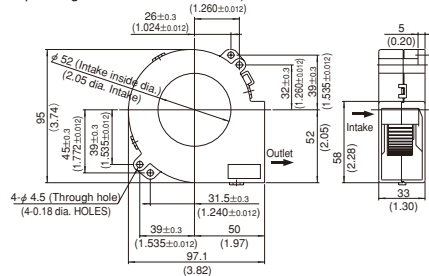

Accessory cord (DCLD030ZT-ZZ01)

This cord is supplied with the terminal type of (-04).
Cords for S and P sensors also optionally available.
(See page G-66.)

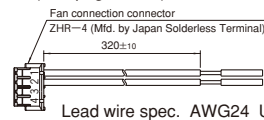

- Terminal output
- 1: (+)
- 2: (-) GND
- 3: S sensor output (Lock detection)
- 4: P sensor output (Pulse output)

Lead wire ends are sheathed to protect the conductors.
(Sheath peeling dimension 10 ±5)

Super silent blower with sensor

Rated Vol.	Model Code						
12 V	E1033H12B5AM-04 (note 1)	E1033H12B6AM-04 (note 1)	E1033H12B7AS-00	E1033H12B8AS-00	E1033H12BAAS-00	E1033Y12BAAS-00	E1033Y12BCAS-00
	E1033H12B5AM-04 (note 1)	E1033H12B6AM-04 (note 1)	E1033H12B7AP-00	E1033H12B8AP-00	E1033H12BAAP-00	E1033Y12BAAP-00	E1033Y12BCAP-00
24 V	E1033H24B5AM-04 (note 1)	E1033H24B6AP-00	E1033H24B7AS-00	E1033H24B8AS-00	E1033H24BAAS-00	E1033Y24BAAS-00	E1033Y24BCAS-00
	E1033H24B5AM-04 (note 1)	E1033H24B6AP-00	E1033H24B7AP-00	E1033H24B8AP-00	E1033H24BAAP-00	E1033Y24BAAP-00	E1033Y24BCAP-00

- AM-04 becomes a lock detection sensor (S) type or pulse sensor (P) type in accordance with the connector connection method.
Note 1: Purchase a sensor output cord (See page G-66) optionally available or the customer shall provide a cord with equivalent specifications if a sensor function is desired.
- NIDEC SERVO can meet many of your requirements for customization, such as special connectors, other sensors not listed above, variable speed specifications, and other modifications. Please contact NIDEC SERVO during your product planning and development stage.
- The listed products are registered in the following overseas standards files, UL/cUL: E48889, TUV: R50004410

Super Silent Blowers

E1232L



119×117×32
(4.7"×4.6"×1.3")
Max. airflow: 1.13 m³/min
Max. static pressure: 460 Pa
Mass: 220 g

Fan model code

- E1232L12B5AP-00
- E1232L12B5AS-00
- E1232L12B5AZ-00
- E1232L12B6AP-00
- E1232L12B6AS-00
- E1232L12B6AZ-00
- E1232L12B7AP-00
- E1232L12B7AS-00
- E1232L12B7AZ-00
- E1232L12B9AP-00
- E1232L12B9AS-00
- E1232L12B9AZ-00
- E1232L24B5AP-00
- E1232L24B5AS-00
- E1232L24B5AZ-00
- E1232L24B6AP-00
- E1232L24B6AS-00
- E1232L24B6AZ-00
- E1232L24B7AP-00
- E1232L24B7AS-00
- E1232L24B7AZ-00
- E1232L24B9AP-00
- E1232L24B9AS-00
- E1232L24B9AZ-00

Standard specification

Max. Airflow		Max. Static Pressure		Noise dB	Speed min ⁻¹	Voltage Spec. V		Current mA		Model Code	Operating Temp. Range °C
m ³ /min	CFM	Pa	inH ₂ O			Rating	Operating Range	Rating	Starting		
1.13	40	460	1.85	54	3800	12	8.4-13.2	1100	2100	E1232L12B9AZ-00	-20 ~ +60
						24	21.6-26.4	560	1900	E1232L24B9AZ-00	
0.91	32	320	1.29	49	3100	12	7.2-13.2	820	1800	E1232L12B7AZ-00	
						24	12-26.4	430	900	E1232L24B7AZ-00	
0.83	29	250	1.01	47	2750	12	7.2-13.2	560	1300	E1232L12B6AZ-00	-20 ~ +70
						24	12-26.4	310	700	E1232L24B6AZ-00	
0.75	26	200	0.80	44	2450	12	7.2-13.2	420	940	E1232L12B5AZ-00	
						24	12-26.4	250	490	E1232L24B5AZ-00	

- Figures in the table are average measured values. Please request the product delivery specification when preparing a purchase specification.
- The characteristics are the values at rated voltage (12 V or 24 V), and normal temperature and humidity.
- The life expectancy of E1232L-7, 9 speed products at rated voltage and in continuous operation is 30,000 hours at 60°C. (40,000 hours for other products)

General specification

Materials Used	Venturi: ABS and PBT synthetic resins Impeller: ABS and PBT synthetic resins Bearing: Both side shielded ball bearing
Motor	Brushless DC motor, Protection type: Current shut off by detecting lock state, automatically reset
Common Elec. Spec.	See pages G-11, G-12, G-13.

Standard airflow and static pressure characteristics (At rated voltage)

[By double chamber method]

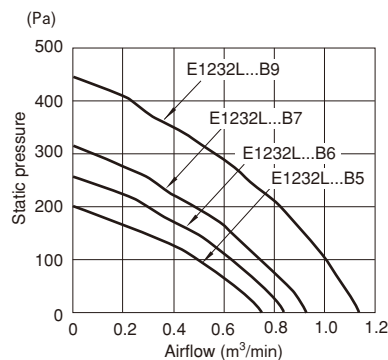

External dimensions in mm (inches)

● Lead wire type

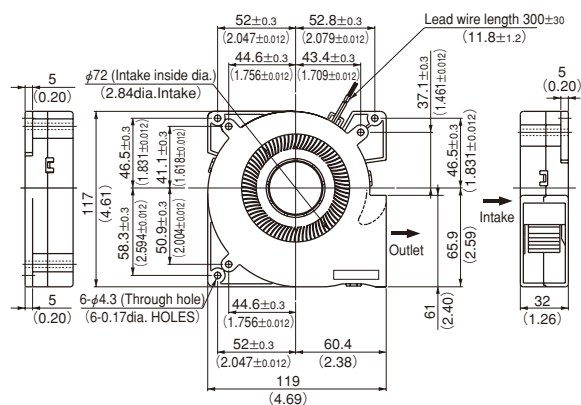

Wiring connection diagram

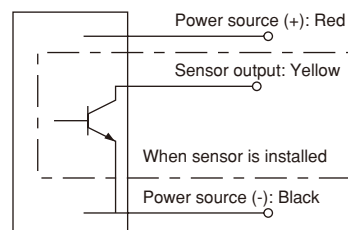

Super silent blower with sensor

Rated Vol.	Model Code			
12 V	E1232L12B5AP-00	E1232L12B6AP-00	E1232L12B7AP-00	E1232L12B9AP-00
	E1232L12B5AS-00	E1232L12B6AS-00	E1232L12B7AS-00	E1232L12B9AS-00
12 V	E1232L24B5AP-00	E1232L24B6AP-00	E1232L24B7AP-00	E1232L24B9AP-00
	E1232L24B5AS-00	E1232L24B6AS-00	E1232L24B7AS-00	E1232L24B9AS-00

- NIDEC SERVO can meet many of your requirements for customization, such as special connectors, other sensors not listed above, variable speed specifications, and other modifications. Please contact NIDEC SERVO during your product planning and development stage.
- The listed products are registered in the following overseas standards files, UL/cUL: E48889, TUV: R50004410

Super Silent Blowers

E1331K



126 × 127 × 32

(5.0" × 5.0" × 1.3")

Max. airflow: 1.08 m³/min

Max. static pressure: 480 Pa

Mass: 250 g

Fan model code

E1331K12B5AP-00

E1331K12B5AS-00

E1331K12B5AZ-00

E1331K12B6AP-00

E1331K12B6AS-00

E1331K12B6AZ-00

E1331K12B7AZ-00

E1331K12B9AP-00

E1331K12B9AS-00

E1331K12B9AZ-00

E1331K24B5AZ-00

E1331K24B6AP-00

E1331K24B6AS-00

E1331K24B6AZ-00

E1331K24B7AP-00

E1331K24B7AS-00

E1331K24B7AZ-00

E1331K24B9AP-00

E1331K24B9AS-00

E1331K24B9AZ-00

Standard specification

Max. Airflow		Max. Static Pressure		Noise dB	Speed min ⁻¹	Voltage Spec. V		Current mA		Model Code	Operating Temp. Range °C
m ³ /min	CFM	Pa	inH ₂ O			Rating	Operating Range	Rating	Starting		
1.08	38	480	1.93	54	3400	12	8.4-13.2	1100	1960	E1331K12B9AZ-00	-20 ~ +60
						24	21-26.4	530	1980	E1331K24B9AZ-00	
0.87	31	310	1.25	49	2700	12	6-13.2	690	1790	E1331K12B7AZ-00	-20 ~ +70
						24	12-26.4	380	930	E1331K24B7AZ-00	
0.79	28	250	1.01	47	2500	12	6-13.2	490	1400	E1331K12B6AZ-00	
						24	12-26.4	280	710	E1331K24B6AZ-00	
0.72	25	210	0.84	45	2200	12	6-13.2	440	1008	E1331K12B5AZ-00	
						24	12-26.4	240	520	E1331K24B5AZ-00	

- Figures in the table are average measured values. Please request the product delivery specification when preparing a purchase specification.
- The characteristics are the values at rated voltage (12 V or 24 V), and normal temperature and humidity.

General specification

Materials Used	Venturi: ABS and PBT synthetic resins Impeller: ABS and PBT synthetic resins Bearing: Both side shielded ball bearing
Motor	Brushless DC motor, Protection type: Current shut off by detecting lock state, automatically reset
Common Elec. Spec.	See pages G-11, G-12, G-13.

Standard airflow and static pressure characteristics (At rated voltage)

[By double chamber method]

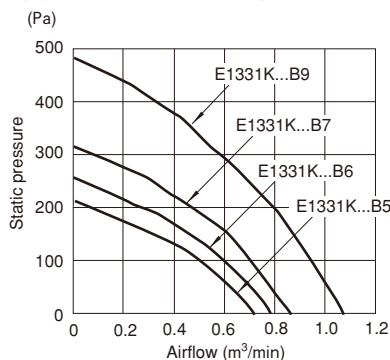

External dimensions in mm (inches)

● Lead wire type

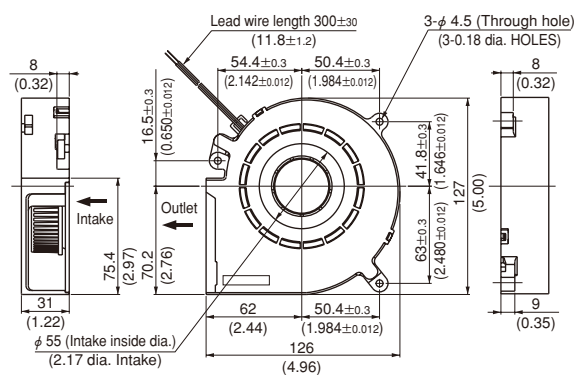

Lead wire spec. AWG24 UL1007 or UL3266
Color (+) Red
(-) Black

Wiring connection diagram

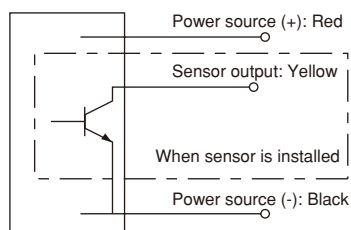

Super silent blower with sensor

Rated Vol.	Model Code			
12 V	E1331K12B5AP-00	E1331K12B6AP-00		E1331K12B9AP-00
	E1331K12B5AS-00	E1331K12B6AS-00		E1331K12B9AS-00
12 V		E1331K24B6AP-00	E1331K24B7AP-00	E1331K24B9AP-00
		E1331K24B6AS-00	E1331K24B7AS-00	E1331K24B9AS-00

- NIDEC SERVO can meet many of your requirements for customization, such as special connectors, other sensors not listed above, variable speed specifications, and other modifications. Please contact NIDEC SERVO during your product planning and development stage.
- The listed products are registered in the following overseas standards files, UL/cUL: E48889, TUV: R50004410

Super Silent Blowers

E1540H



150×152×40
(5.9"×6.0"×1.6")
Max. airflow: 2.0 m³/min
Max. static pressure: 430 Pa
Mass: 380 g

Fan model code

- E1540H12B5AS-00
- E1540H12B5AZ-00
- E1540H12B7AP-00
- E1540H12B7AS-00
- E1540H12B7AZ-00
- E1540H24B5AS-00
- E1540H24B5AZ-00
- E1540H24B7AP-00
- E1540H24B7AS-00
- E1540H24B7AZ-00

Standard specification

Max. Airflow		Max. Static Pressure		Noise dB	Speed min ⁻¹	Input W	Voltage Spec. V		Current mA		Model Code	Operating Temp. Range °C
m ³ /min	CFM	Pa	inH ₂ O				Rating	Operating Range	Rating	Starting		
2.0	71	430	1.73	56	2700	19.4	12	8.4-13.8	1600	910	E1540H12B7AZ-00	-20 ~ +70
						17.8	24	16.8-27.6	740	430		
1.65	58	270	1.09	51	2200	13	12	8.4-13.8	1100	1640	E1540H12B5AZ-00	
							24	12-27.6	540	1450		

- Figures in the table are average measured values. Please request the product delivery specification when preparing a purchase specification.
- The characteristics are the values at rated voltage (12 V or 24 V), and normal temperature and humidity.
- The life expectancy of E1540H-7 speed products at rated voltage and in continuous operation is 30,000 hours at 60°C. (40,000 hours for other products)

General specification

Materials Used	Venturi: ABS and PBT synthetic resins Impeller: ABS and PBT synthetic resins Bearing: Both side shielded ball bearing
Motor	Brushless DC motor, Protection type: Overcurrent detection and automatic resetting by current limiting
Common Elec. Spec.	See pages G-11, G-12, G-13.
Standard Carton	16 to a carton of (450 x 380 x 220) mm, mass 7 kg

Standard airflow and static pressure characteristics (At rated voltage)

[By double chamber method]

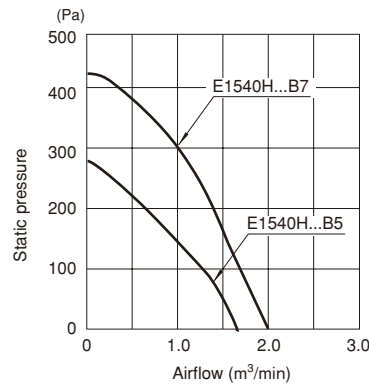

External dimensions in mm (inches)

● Lead wire type

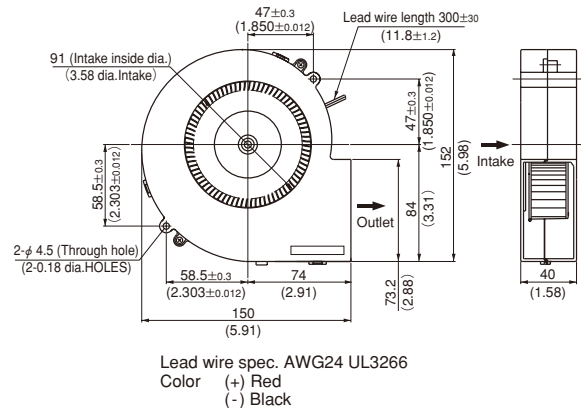

Wiring connection diagram

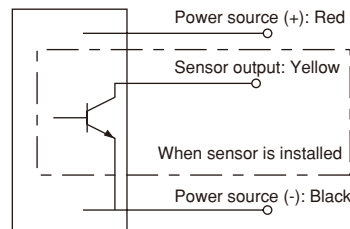

Super silent blower with sensor

Rated Vol.	Model Code	
12 V	E1540H12B5AS-00	E1540H12B7AS-00
		E1540H12B7AP-00
24 V	E1540H24B5AS-00	E1540H24B7AS-00
		E1540H24B7AP-00

- NIDEC SERVO can meet many of your requirements for customization, such as special connectors, other sensors not listed above, variable speed specifications, and other modifications. Please contact NIDEC SERVO during your product planning and development stage.
- The listed products are registered in the following overseas standards files, UL/cUL: E48889, TUV: R50004410
- 3D data is also available at our web2-CAD site (www.cadenas.co.jp).

Super Silent Blowers

E2271Z

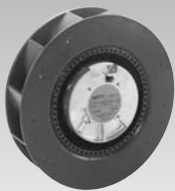

$\phi 220 \times 71$ ($\phi 8.7'' \times 2.8''$)
Max. airflow: 18.1 m³/min
Max. static pressure: 650 Pa
Mass: 1300 g

Features

- Large airflow, high static pressure backward blowers without housing.
- A low noise effect can be achieved by combining an inlet ring.

Fan model code

E2271Z24B5YP-00
E2271Z48B7AP-00

Standard specification

Max. Airflow		Max. Static Pressure		Noise	Speed	Voltage Spec. V		Current mA		Model Code	Operating Temp. Range °C
m ³ /min	CFM	Pa	inH ₂ O	dB	min ⁻¹	Rating	Operating Range	Rating	Starting		
18.1	639	650	2.61	71	3200	48	36-57	2100	4500	E2271Z48B7AP-00	-20 ~ +60
14.7	519	470	1.89	69	2650	24	21.0-26.4	2600	3800	E2271Z24B5YP-00	-20 ~ +40

- Figures in the table are average measured values. Please request the product delivery specification when preparing a purchase specification.
- The characteristics are the values at rated voltage (24V, or 48 V), and normal temperature and humidity.
- This product has limitations to ON/OFF functionality. For details, please reference the relevant diagrams in the specification.

General specification

Materials Used	Ventur: Aluminum alloy die castings Impeller: ABS and PBT synthetic resins Bearing: Both side shielded ball bearing
Motor	Brushless DC motor, Protection type: Overcurrent detection and automatic resetting by current limiting
Common Elec. Spec.	See pages G-11, G-12, G-13.

Standard airflow and static pressure characteristics (At rated voltage)

[By double chamber method]
(Performance when an inlet ring is combined)

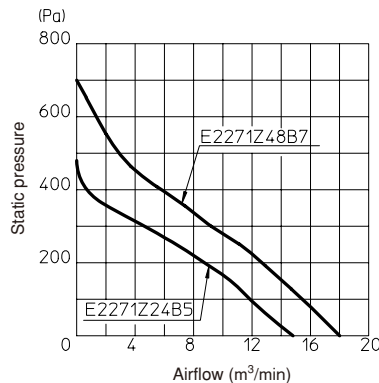

Wiring connection diagram

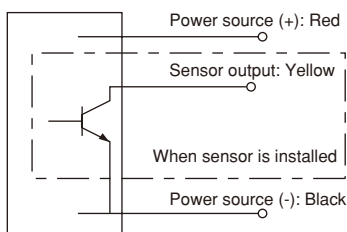

External dimensions in mm (inches)

• Lead wire type

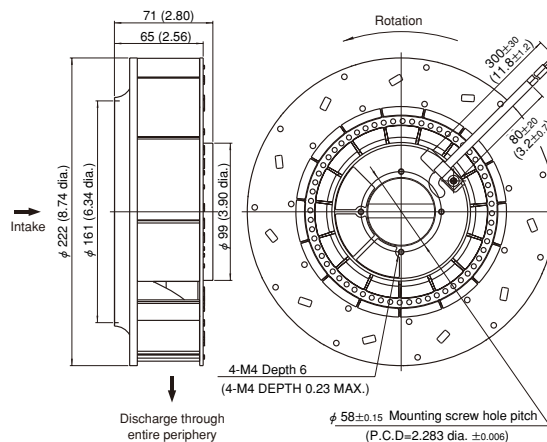

Lead wire spec. AWG24 UL3266
Color (+) Red
(-) Black
(sensor) Yellow

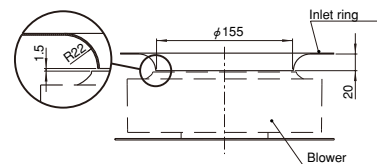

With an inlet ring installed (S = N.T.S.)

Options (sold separately)

- E2271 inlet ring

Products for variable-speed operation by PWM, voltage or resistance value commands can also be supplied with this model. (See pages G-51 and 52.)
Contact NIDEC SERVO for further information.

Super silent blower with sensor

Rated Vol.	Model Code
24 V	E2271Z24B5YP-00
48 V	E2271Z48B7AP-00

- This product features a large airflow and high static pressure without using a housing. A standard specification is ensured if installed complying with the foregoing bell mouth shape and its position.
- See page G-73 for detailed dimensions of the intake bell mouth.
- A bell mouth fitting accessory (product code E2271 Inlet Ring) is available as an option. (See page G-65.)
- NIDEC SERVO can meet many of your requirements for customization, such as special connectors, other sensors not listed above, variable speed specifications, and other modifications. Please contact NIDEC SERVO during your product planning and development stage.
- The listed products are registered in the following overseas standards files, UL/cUL: E48889, TUV: R9451586 (E2271Z48B7 only models.)

Fan model code
D0925C12B8ZP-00
D0925C24B8ZP-00
D1238B48B7ZP-00
D1751M24B4ZP-00
D1751M24B5ZP-00
D1751M24B6ZP-00
D1751M24B7ZP-00
D1751M24B8ZP300
D1751M24B9ZP300
D1751M48B4ZP-00
D1751M48B5ZP-00
D1751M48B6ZP-00
D1751M48B7ZP-00
D1751M48B8ZP-00
D1751M48B9ZP-00
D1751S24B4ZP-00
D1751S24B5ZP-00
D1751S24B6ZP-00
D1751S24B6ZQ-00
D1751S24B7ZP-00
D1751S24B8ZP300
D1751S24B9ZP300
D1751S48B4ZP-00
D1751S48B5ZP-00
D1751S48B6ZP-00
D1751S48B7ZP-00
D1751S48B8ZP-00
D1751S48B9ZP-00
D1751S24B4ZR-13
E1033H12B8ZS-00
E1033H12BAZP-00
E1033H24BAZP-00
E1033H24BAZS-00
E2271Z24B5YP-00
E2271Z48B7ZP-00

Lineup of PWM variable-speed semi-standard products

● A PWM signal from the customer equipment is input to the control line (blue) of the fan motor for variable-speed operation of fans and blowers. (Input and noise can be reduced when the internal temperature of the customer equipment is low, such as during idling.)

- Sizes
Axial fans: □60 mm~□172 mm
Blower: □70 mm~φ220 mm

Characteristics for reference

(The characteristics are typical characteristics and their curves will differ, depending on the particular model)

- Standard values for PWM control signal - speed specification (at rated voltage, open, and normal temperature and humidity)

I _{out}	1 mA MAX.
V _{out}	5 V. MAX.
V _{Losat}	0.4 MAX.
Freq.	500 Hz~5000 Hz

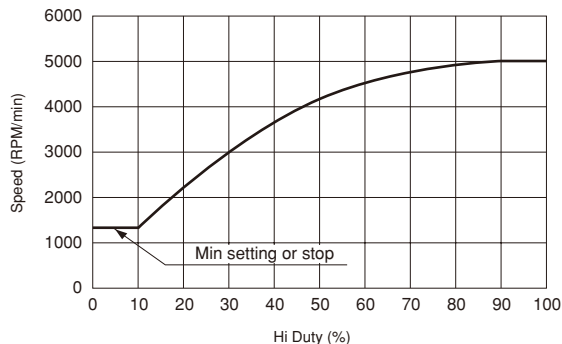
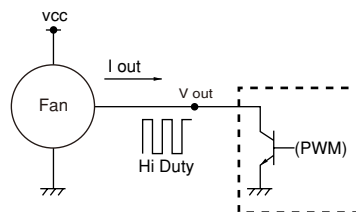

Semi-standard products (Products in regular production)

Size	Model Code	Max. Airflow		Max. Static Pressure		Noise dB	Speed min ¹		Voltage Spec. V		Operating Temp. Range °C		
		m ³ /min	CFM	Pa	inH ₂ O		Max.	Min.	Rating	Operating Range			
□92×25mm	D0925C12B8ZP-00	2	71	67	0.27	40	4450	1000	12	10.2-13.2	-20 ~ 60°C		
	D0925C24B8ZP-00						4450	1750	24	21.6-26.4			
□120×38mm	D1238B48B7ZP-00	4.4	155	170	0.68	54	4000	1250	48	40.8-55.2	-20 ~ 70°C		
	D1751M24B9ZP300						14.2	501	580	2.33		75	6800
φ172×150×51mm	D1751M48B9ZP-00	12.7	448	510	2.05	72	6100	2600	48	36-60	-20 ~ 70°C		
	D1751M24B8ZP300								24	16-28			
	D1751M48B8ZP-00	11.4	402	410	1.65	69	5400	1500	48	36-60			
	D1751M24B7ZP-00								24	12-27.6			
	D1751M48B7ZP-00	10.2	360	315	1.27	64	4800	1000	48	36-60			
	D1751M24B6ZP-00								24	12-27.6			
	D1751M48B6ZP-00	9	318	260	1.04	61	4200	1000	48	36-60			
	D1751M24B5ZP-00								24	12-27.6			
	D1751M48B5ZP-00	8	282	205	0.82	57	3800	1000	48	36-60			
	D1751M24B4ZP-00								24	12-27.6			
	φ172×51mm	D1751M48B4ZP-00	14.2	501	640	2.57	68	6800	3200	24		16-28	-20 ~ 60°C
		D1751S24B9ZP300								48		36-60	
D1751S48B9ZP-00		12.7	448	520	2.09	65	6100	2600	24	16-28			
D1751S24B8ZP300									48	36-60			
D1751S48B8ZP-00		11.4	402	435	1.75	62	5400	1500	24	12-27.6			
D1751S24B7ZP-00									48	36-60			
D1751S48B7ZP-00		10.2	360	335	1.35	59	4800	1000	24	12-27.6			
D1751S24B6ZP-00									48	36-60			
D1751S48B6ZP-00		9	318	270	1.08	56	4200	1000	24	12-27.6			
D1751S24B5ZP-00									48	36-60			
D1751S48B5ZP-00		8	282	220	0.88	53.5	3800	1000	24	12-27.6			
D1751S24B4ZP-00									48	36-60			
D1751S48B4ZP-00	8	282	230	0.92	53.5	3800	1500	24	20.4-27.6				
D1751S24B4ZR-13								24	20.4-27.6				
97×95×33mm (Blowers)	E1033H12B8ZS-00	0.85	30	320	1.29	51	3450	1250	12	10.8-13.2	-20 ~ 70°C		
	E1033H12BAZP-00								24	21.6-26.4			
	E1033H24BAZP-00	1.14	40	500	2.01	58	4850	1800	24	21.6-26.4			
	E1033H24BAZS-00								24	21.6-26.4			
φ220×71mm (Blowers)	E2271Z48B7ZP-00	18.1	639	600	2.41	74	3200	1000	48	36-57	-20 ~ 60°C		
	E2271Z24B5YP-00								24	21.6-26.4			
		14.7	519	470	1.89	66	2650	530	24	21.6-26.4	-20 ~ 40°C		

※ The D1751S24B4ZR-13 is a FFU (Fan Filter Unit) product. Only this version allows for voltage designed speed variation

- Aside from the above models, please see also the high pressure, variable speed G series fans.
- The lineup of variable-speed fans and blowers will be expanded regularly. Visit the NIDEC SERVO Website for information on the latest lineup.
- Direct your inquiry to NIDEC SERVO for connector termination to lead wires, for sensor specifications other than those contained in the catalog and for variable speed specifications. (Products tailored to voltage command control and resistance value command control are also available)
- To ensure correct installation and smooth operation please obtain a drawing for approval or reference drawing from NIDEC SERVO Co.

Fully customized products

Fully customized products will be manufactured to optimally match your equipment for high volume needs. (more than 10,000 units/month) for home appliances such as refrigerators, air conditioners and washing machines and for industrial machinery and information communication equipment, including open showcases, power sources and computer-related equipment. Please contact NIDEC SERVO for more information.



Fully customized product example 1



Fully customized product example 2



Fully customized product example 3

Semi-customized products

Semi-customized products, including the following, will be manufactured by combining a large variety of components available to NIDEC SERVO. Please contact NIDEC SERVO for more information.

- 1) For operation in a high-temperature atmosphere of 80 °C.
- 2) Long life products (60,000 hours or longer at 60 °C, 100,000 hours at 50 °C)
- 3) Energy saving products (30 % to 50 % less input compared with conventional products)
- 4) IP55 products (Outdoor installation and in a high-humidity environment)
- 5) Variable-speed products (PWM, voltage or resistance value command), dual-speed products
- 6) Fans for high static pressure regions (92 mm sq. x 38 mm thick, 120 mm sq. x 38 mm thick, 172 mm dia. x 51 mm thick and others)
- 7) Fans to prevent galvanic corrosion of ball bearings (ceramic ball specification)

Fan tray units

- Tray units fitted with a standard or semi-customized fans.
- Tray shape designed, manufactured and tailored to customer specifications.

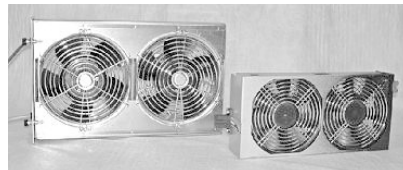

Fan tray unit example 1



Fan tray unit example 2



Fan unit example

AC Silent Fan
SCUA



□ 120 × φ 128 × 25
(□ 4.7" × φ 5.6" × 1.0")
Max. airflow: 1.9 m³/min (50 Hz)
2.2 m³/min (60 Hz)
Max. static pressure:
41 Pa (50 Hz) 45 Pa (60 Hz)
Mass: 330 g

Fan model code

SCUA2B5

SCUA47F5

SCUA52B5

SCUA55B5

SCUJ47F5

SCUJ48F5

SCUJ55B5

SCUJ60B5

Standard specification

(Input and current are indicated on name plate)

Max. Airflow		Max. Static Pressure		Noise	Speed	Rated Vol. V (±10%)	Freq. Hz	Input W	Current mA	Lock Current mA	Model Code			
m ³ /min	CFM	Pa	inH ₂ O								dB	min ⁻¹	Lead Wire Type	Std*
1.9/ 2.2	67/ 78	41/ 45	0.17/ 0.18	34/ 39	2350/ 2750	100	50/ 60	13/11	190/140	190/165	SCUA55B5	(U)	SCUJ55B5	P
								13.5/11	90/70	100/85				
								14/11	160/130	175/150	SCUA2B5	(U)		
								14/11	90/70	90/75	SCUA52B5	(U)		
1.2/ 1.45	42/ 51	15/ 22	0.06/ 0.09	24.5/ 29	1500/ 1900	100-120/ 200-240	50/ 60	15/11.5	170/130	175/130	SCUA47F5	(U)	SCUJ47F5	P
								15/11.5	80/60	90/65				

- Figures in the table are average measured values. Please request the product delivery specification when preparing a purchase specification.
- *(U) in the standards column denotes products conforming to UL standard (certification not obtained as yet).
- *Products conforming to the specifications of the Electrical Appliance and Material Safety Law (Japan) can be used in case the products are assembled in electric appliances used in Japan. (Products marked with the (PSE)E mark)

General specification

Materials Used	Venturi: Aluminum alloy die casting Propeller: Glass fiber reinforced polycarbonate resin Bearing: Double - sided shielded ball bearing
Motor	Shaded pole induction motor Protection type: Impedance protection
Common Elec. Spec.	See pages G-12.
Usage Range	Rated voltage ±10 %
Operating Temp. Range	-20 °C ~ +60 °C
Standard Carton	30 to a carton of (560 x 300 x 190) mm, mass 10 kg

● Guard mounting

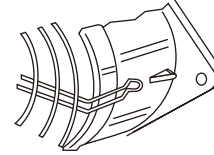

The guard for the intake side (SCU guard) can be mounted with one touch without using a tool.

Standard airflow and static pressure characteristics (At rated voltage)

SCU□□B5

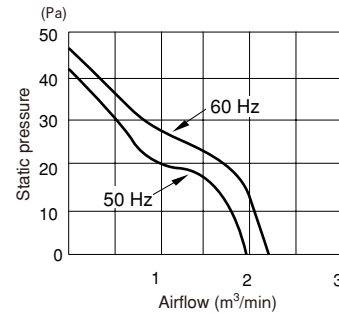

SCU□□F5

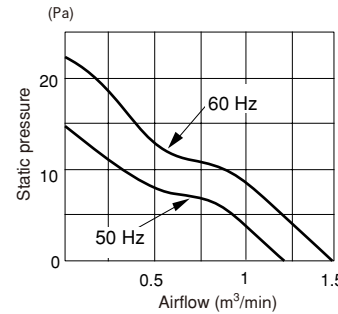

External dimensions in mm (inches)

● Lead wire type

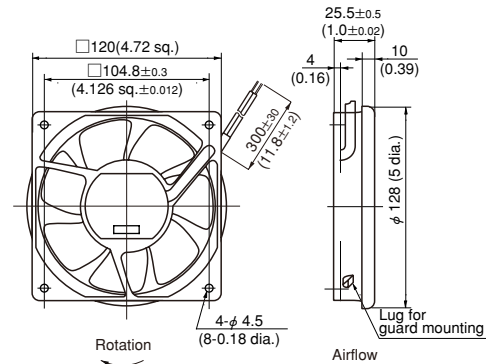

Lead wire specification
SCUJ series: Heat resistant PVC 0.75 mm² (30 conductors, 0.18 dia.)
SCUA series: AWG22 UL1015

Options (sold separately)

- Guard: F120UL guard (Outlet side)
- Guard: SCU guard (Intake side)

Mounting hole dimensions in mm (inches)
[Recommendation]

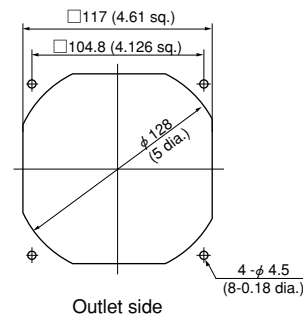

AC Silent Fan
SCNA



□ 120 × ϕ 128 × 38
(□ 4.7" × ϕ 5.0 × 1.5")
Max. airflow: 2.6 m³/min (50 Hz)
3.1 m³/min (60 Hz)
Max. static pressure:
80 Pa (50 Hz) 80 Pa (60 Hz)
Mass: 550 g

Fan model code

- SCNA2B5
- SCNA47D5
- SCNA48D5
- SCNA52B5
- SCNA55B5
- SCNA60B5
- SCNJ47D5
- SCNJ48D5
- SCNJ55B5
- SCNJ60B5

Standard specification

(Input and current are indicated on name plate)

Max. Airflow		Max. Static Pressure		Noise dB	Speed min ⁻¹	Rated Vol. V (±10 %)	Freq. Hz	Input W	Current mA	Lock Current mA	Model Code				
m ³ /min	CFM	Pa	inH ₂ O								Lead Wire Type	Std*	Lead Wire Type	Std*	
2.6/ 3.1	92/ 109	80/ 80	0.32/ 0.32	38/ 42	2800/ 3300	100	50/	14/12	200/180	300/270	SCNA55B5	UC			
								15/13	200/180	300/270			SCNJ55B5	P	
								14/12	110/90	155/135	SCNA60B5	UC			
								15/13	110/90	155/135			SCNJ60B5	P	
								16/13	200/170	300/260	SCNA2B5	UC			
								208-230	14/13	110/90	160/140	SCNA52B5	UC		
1.7/ 1.9	60/ 67	25/ 26	0.10/ 0.11	28/ 31	1890/ 2030	100-120	50/	9/8.5	110/90	110/95	SCNA47D5	UC			
								100-120	8.5/8	110/90	110/95			SCNJ47D5	P
								200-240	9/8.5	60/50	60/50	SCNA48D5	UC		
								200-240	8.5/8	60/50	60/50			SCNJ48D5	P

- Figures in the table are average measured values. Please request the product delivery specification when preparing a purchase specification.
- *The symbols in the standards column denote that they are registered in the following standards files, U: UL E48889, C: CSA LR49399, LR108118
- *Products conforming to the specifications of the Electrical Appliance and Material Safety Law (Japan) can be used in case the products are assembled in electric appliances used in Japan. (Products marked with the (PS)E mark)

General specification

Materials Used	Venturi: Aluminum alloy die casting Propeller: Glass fiber reinforced polycarbonate resin Bearing: Double - sided shielded ball bearing
Motor	Shaded pole induction motor Protection type: Impedance protection
Common Elec. Spec.	See pages G-12.
Usage Range	Rated voltage ± 10 %
Operating Temp. Range	-20 °C ~ +60 °C
Standard Carton	20 to a carton of (565 x 310 x 180) mm, mass 11.5 kg

Guard mounting

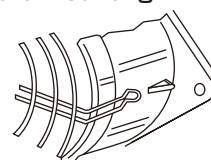

The guard for the intake side (SCN guard) can be mounted with one touch without using a tool.

Standard airflow and static pressure characteristics (At rated voltage)

SCN□□B5

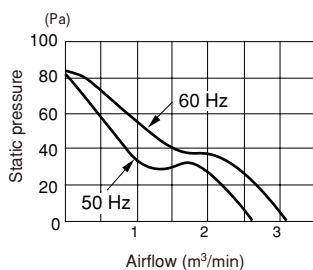

SCN□□D5

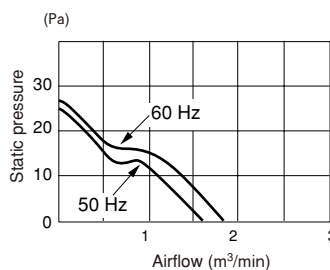

External dimensions in mm (inches)

Lead wire type

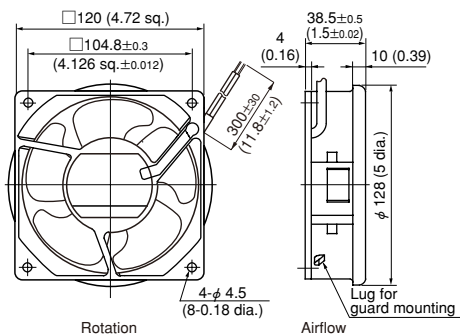

Mounting hole dimensions in mm (inches)
[Recommendation]

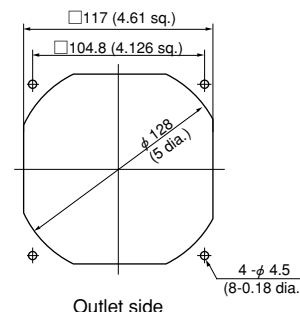

Lead wire specification
SCNJ series: Heat resistant PVC 0.75 mm² (30 conductors, 0.18 dia.)
SCNA series: AWG22 UL1015

Options (sold separately)

- Guard: F120UL guard (Outlet side)
- Guard: SCN guard (Intake side)

Fans & Blowers

Axial
DC fans
Centrifugal

Silent

AC fans
Axial

Centrifugal

Option

AC Axial Fan
VE



□ 80 × 25 (□ 3.2" × 1.0")
 Max. airflow: 0.55 m³/min (50 Hz)
 0.65 m³/min (60 Hz)
 Max. static pressure:
 42 Pa (50 Hz) 60 Pa (60 Hz)
 Mass: 250 g

Fan model code

- VE115B5
- VE2B5
- VE47F5
- VE48F5
- VE50B5
- VE52B5
- VE55B5
- VE60B5
- VEJ47F5
- VEJ48F5
- VEJ55B5
- VEJ60B5

Standard specification

(Input and current are indicated on name plate)

Max. Airflow		Max. Static Pressure		Noise dB	Speed min ⁻¹	Rated Vol. V (±10%)	Freq. Hz	Input W	Current mA	Lock Current mA	Model Code			
m ³ /min	CFM	Pa	inH ₂ O								Lead Wire Type	Std*	Lead Wire Type	Std*
0.55 /0.65	19 /23	42/ 60	0.17/ 0.24	30/ 35	2750/ 3300	100	50/ 60	11/9	130/110	130/110	VE55B5	U	VEJ55B5	P
								11/8.5	80/70	80/75	VE60B5	U	VEJ60B5	P
								11/9	130/100	170/130	VE2B5	U		
								11/10	70/60	75/65	VE52B5	U		
								11/9	140/110	140/110	VE115B5	UTV		
0.56/ 0.68	20 /24	45/ 66	0.18/ 0.27	30/ 35	2750/ 3300	220/230		9/8	70/60	75/65	VE50B5	UTV		
0.37/ 0.48	13 /17	17/ 29	0.07/ 0.12	27/ 31	1800/ 2300	100-120	50/ 60	12/10	130/110	130/110	VE47F5	TV	VEJ47F5	P
						200-240		12/10	70/60	70/60	VE48F5	TV	VEJ48F5	P

- Figures in the table are average measured values. Please request the product delivery specification when preparing a purchase specification.
- *The symbols in the standards column denote that they are registered in the following standards files. U: UL E48889, T: TUV R60229-60302, V: VDE 3019UG
- *Products conforming to the specifications of the Electrical Appliance and Material Safety Law (Japan) can be used in case the products are assembled in electric appliances used in Japan. (Products marked with the (PS)E mark)

General specification

Materials Used	Venturi: Aluminum alloy die casting Propeller: Glass fiber reinforced polycarbonate resin Bearing: Double - sided shielded ball bearing
Motor	Shaded pole induction motor Protection type: Impedance protection
Common Elec. Spec.	See pages G-12.
Usage Range	Rated voltage ±10 %
Operating Temp. Range	-20 °C ~ +60 °C (-20 °C ~ +55 °C in TÜV standard -20 °C ~ +40 °C in VDE standard)
Standard Carton	40 to a carton of (450 x 380 x 160) mm, mass 11 kg

Standard airflow and static pressure characteristics (At rated voltage)

VE□□B5

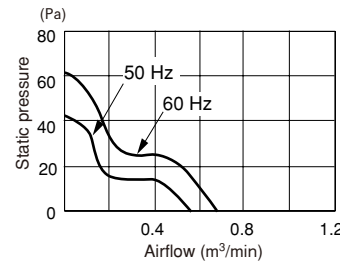

VE□□F5

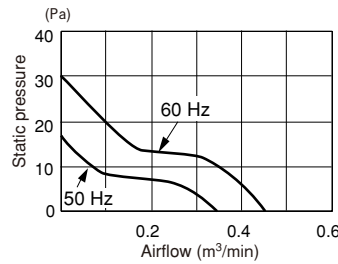

External dimensions in mm (inches)

● Lead wire type

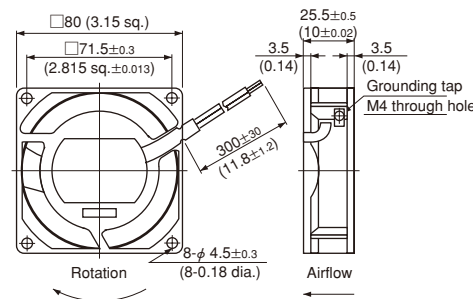

Lead wire specification
 VEJ series: Heat resistant PVC 0.75 mm² (30 conductors, 0.18 dia.)
 VE series: AWG22 UL1015

Mounting hole dimensions in mm (inches)
[Recommendation]

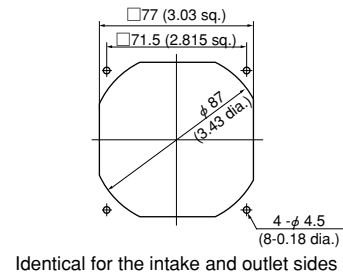

Identical for the intake and outlet sides

Options (sold separately)

- Guard: F80UL guard
- Filter: F80 filter

AC Axial Fan
WE



□ 92 × 25 (□ 3.6" × 1.0")
 Max. airflow: 0.85 m³/min (50 Hz)
 1.0 m³/min (60 Hz)
 Max. static pressure:
 49 Pa (50 Hz) 67 Pa (60 Hz)
 Mass: 290 g

Fan model code

- WE115B5
- WE2B3
- WE2B5
- WE47F3
- WE47F5
- WE48F3
- WE48F5
- WE50B5
- WE52B3
- WE52B5
- WE55B3
- WE55B5
- WE60B3
- WE60B5
- WEJ55B5
- WEJ60B5

Standard specification

(Input and current are indicated on name plate)

Max. Airflow m ³ /min	Max. Static Pressure CFM	Max. Static Pressure		Noise dB	Speed min ⁻¹	Rated Vol. V (±10%)	Freq. Hz	Input W	Current mA	Lock Current mA	Model Code			
		Pa	inH ₂ O								Lead Wire Type	Std*	Terminal Type	Std*
0.85/ 1.0	30/ 35	49/ 67	0.20/ 0.27	35/ 40	2700/ 3200	100	50/ 60	11/9	130/110	140/130	WE55B5	UC	WE55B3	UCP
								9/7.5	130/110	140/130	WEJ55B5	P		
								12/10	70/60	80/75	WE60B5	UC	WE60B3	UCP
								12/10	70/60	80/75	WEJ60B5	P		
								11/9	120/100	140/120	WE2B5	UC	WE2B3	UCP
								11/10	70/60	75/70	WE52B5	UC	WE52B3	UCP
0.85/ 1.0	30/ 35	52/ 74	0.21/ 0.30	35/ 40	2700/ 3200	220/230	50/ 60	11/10	80/70	90/80	WE50B5	UTV		
0.55/ 0.68	19/ 24	19/ 27	0.07/ 0.11	25/ 30	1750/ 1750	100-120/ 200-240	50/ 60	12/10	120/110	120/110	WE47F5	UTV	WE47F3	UP
								12/10	80/60	80/60	WE48F5		WE48F3	UP

- Figures in the table are average measured values. Please request the product delivery specification when preparing a purchase specification.
- *The symbols in the standards column denote that they are registered in the following standards files, U: UL E48889, T: TUV R60229-60302, V: VDE 3019UG
- *Products conforming to the specifications of the Electrical Appliance and Material Safety Law (Japan) can be used in case the products are assembled in electric appliances used in Japan. (Products marked with the (PS)E mark)

General specification

Materials Used	Venturi: Aluminum alloy die casting Propeller: Glass fiber reinforced polycarbonate resin Bearing: Double - sided shielded ball bearing
Motor	Shaded pole induction motor Protection type: Impedance protection
Common Elec. Spec.	See pages G-12.
Usage Range	Rated voltage ±10%
Operating Temp. Range	-20 °C ~ +60 °C (-20 °C ~ +55 °C in TUV standard) (-20 °C ~ +40 °C in VDE standard)
Standard Carton	40 to a carton of (480 x 380 x 160) mm, mass 12 kg

Standard airflow and static pressure characteristics (At rated voltage)

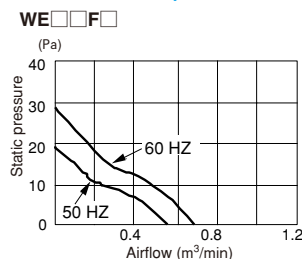
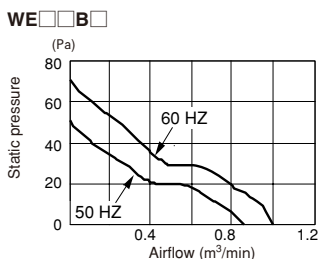

External dimensions in mm (inches)

● Lead wire type (WE□□□5)

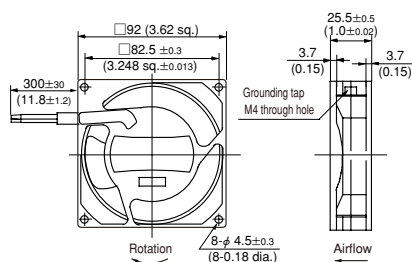

● Terminal type [2 terminals: with grounding tap] (WE□□□3)

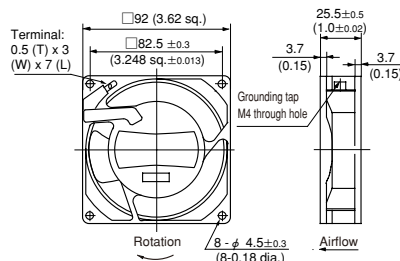

Lead wire specification
 WEJ series: Heat resistant PVC 0.75 mm² (30 conductors, 0.18 dia.)
 WE series: AWG22 UL1015

Mounting hole dimensions in mm (inches)
[Recommendation]

Options (sold separately)

- Guard: F92UL guard
- Filter: F92 filter
- Power code: T2P1 code, D2P1 code, UL2P1 code

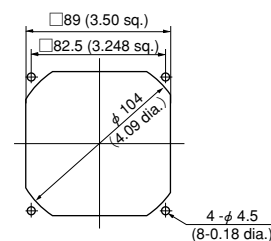

Identical for the intake and outlet sides

AC Axial Fan

KA



□92 × 38 (□3.6" × 1.5")

Max. airflow: 1.1 m³/min (50 Hz)
1.3 m³/min (60 Hz)

Max. static pressure:
62 Pa (50 Hz) 80 Pa (60 Hz)
Mass: 450 g

Fan model code

KA2B3

KA2B4

KA47D3

KA47D5

KA52B3

KA52B5

KA55B3

KA55B4

KA60B3

KA60B5

KAJ55B4

KAJ60B5

Standard specification

(Input and current are indicated on name plate)

Max. Airflow		Max. Static Pressure		Noise	Speed	Rated Vol.	Freq.	Input	Current	Lock	Model Code			
m ³ /min	CFM	Pa	inH ₂ O	dB	min ⁻¹	V (±10%)	Hz	W	mA	Current mA	Lead Wire Type	Std*	Terminal Type	Std*
1.1/ 1.3	39/ 46	62/ 80	0.25/ 0.32	31/ 38	2850/ 3300	100	50/	8.5/8	200/160	200/160	KA55B4	U	KA55B3	UP
								7/6	200/160	200/160	KAJ55B4	P		
								8.5/8	100/70	100/75	KA60B5	U	KA60B3	UP
								7/6	100/70	100/75	KAJ60B5	P		
								8.5/8	180/150	180/150	KA2B4	U	KA2B3	UP
0.8/ 0.9	28/ 32	29/ 36	0.12/ 0.15	26/ 28	2250/ 2650	100-120	50/ 60	8.5/8	90/70	90/70	KA52B5	U	KA52B3	UP
								8/7	180/150	180/150	KA47D5	U	KA47D3	UP

● Figures in the table are average measured values. Please request the product delivery specification when preparing a purchase specification.

● *The symbols in the standards column denote that they are registered in the following standards files, U: UL E48889

● *Products conforming to the specifications of the Electrical Appliance and Material Safety Law (Japan) can be used in case the products are assembled in electric appliances used in Japan. (Products marked with the (PS)E mark)

General specification

Materials Used	Venturi: Aluminum alloy die casting Propeller: PBT resin Bearing: Double - sided shielded ball bearing
Motor	Shaded pole induction motor Protection type: Impedance protection
Common Elec. Spec.	See page G-12.
Usage Range	Rated voltage ±10 %
Operating Temp. Range	-20 °C ~ +60 °C
Standard Carton	20 to a carton of (450 x 380 x 150) mm, mass 10 kg

Standard airflow and static pressure characteristics (At rated voltage)

KA□□B□

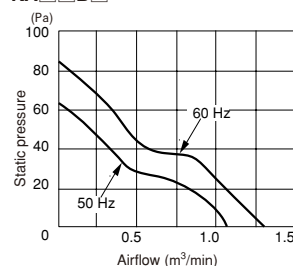

KA□□D□

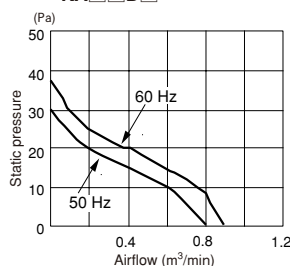

External dimensions in mm (inches)

● Lead wire type (KA□□□4/KA□□□5)

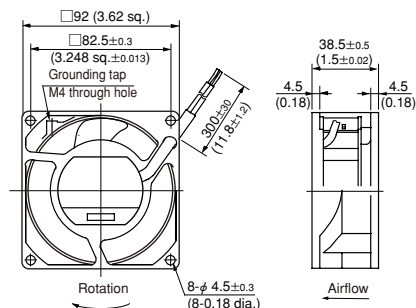

Lead wire specification

KAJ series: Heat resistant PVC 0.75 mm² (30 conductors, 0.18 dia.)

KA series: AWG22 UL1015

● Terminal type (KA□□□3)

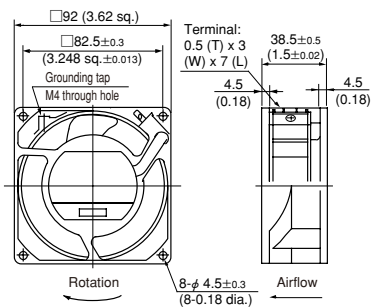

Mounting hole dimensions in mm (inches)
[Recommendation]

Options (sold separately)

- Guard: F92UL guard
- Filter: F92 filter
- Power code: T2P1 code, D2P1 code, UL2P1 code

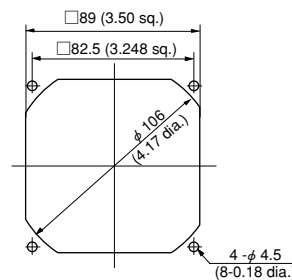

Identical for the intake and outlet sides

AC Axial Fan
CU



□ 120 × 25 (□ 4.7" × 1.0")

Max. airflow: 1.9 m³/min (50 Hz)
2.2 m³/min (60 Hz)

Max. static pressure:
53 Pa (50 Hz) 56 Pa (60 Hz)
Mass: 360 g

Fan model code

- CU115B5
- CU2B3
- CU2B5
- CU47F3
- CU47F5
- CU48F3
- CU48F5
- CU50B5
- CU52B3
- CU52B5
- CU55B3
- CU55B5
- CU60B3
- CU60B5
- CUJ47F5
- CUJ55B5
- CUJ60B5

Standard specification

(Input and current are indicated on name plate)

Max. Airflow m ³ /min	Max. Static Pressure Pa	Noise dB	Speed min ⁻¹	Rated Vol. V (±10%)	Freq. Hz	Input W	Current mA	Lock Current mA	Model Code				
									Lead Wire Type	Std*	Terminal Type	Std*	
1.9/ 2.2	67/ 78	53/ 56	0.21/ 0.23	40/ 45	2550/ 3000	100	16/14.5	190/140	200/170	CU55B5	UC	CU55B3	UCP
										CUJ55B5	P		
										CU60B5	UC		
										CUJ60B5	P		
										CU60B3	UCP		
										CU2B5	UC	CU2B3	UCP
										CU52B5	UC		
										CU52B3	UCP		
										CU115B5	UTV		
										CU50B5	UTV		
1.92/ 2.26	68/ 80	58/ 65	0.23/ 0.26	40/ 45	2550/ 3000	220/230	14/13	90/70	100/80	CU50B5	UTV		
1.2/ 1.4	42/ 49	19/ 24	0.07/ 0.10	27/ 34	1500/ 1900	100-120 100-120 200-240 200-240	14/11 14/10.5 14/11 14/10.5	170/130 170/130 80/60 80/60	170/130 170/130 80/60 80/60	CU47F5	UCT	CU47F3	UCP
										CUJ47F5	P		
										CU48F5	UCT		
										CU48F3	UCT		
										CU48F5	UCT		
										CU48F3	UCT		

- Figures in the table are average measured values. Please request the product delivery specification when preparing a purchase specification.
- *The symbols in the standards column denote that they are registered in the following standards files, U: UL E48889, C: CSA LR49399, LR108118, T: TUV R60229-60302, V: VDE 3019UG
- *Products conforming to the specifications of the Electrical Appliance and Material Safety Law (Japan) can be used in case the products are assembled in electric appliances used in Japan. (Products marked with the (PS)E mark)

General specification

Materials Used	Venturi: Aluminum alloy die casting Propeller: Glass fiber reinforced polycarbonate resin Bearing: Double - sided shielded ball bearing
Motor	Shaded pole induction motor Protection type: Impedance protection
Common Elec. Spec.	See page G-12.
Usage Range	Rated voltage ±10 %
Operating Temp. Range	-20 °C ~ +60 °C (-20 °C ~ +55 °C in TUV standard) (-20 °C ~ +40 °C in VDE standard)
Standard Carton	30 to a carton of (450 x 380 x 160) mm, mass 12 kg

Standard airflow and static pressure characteristics (At rated voltage)

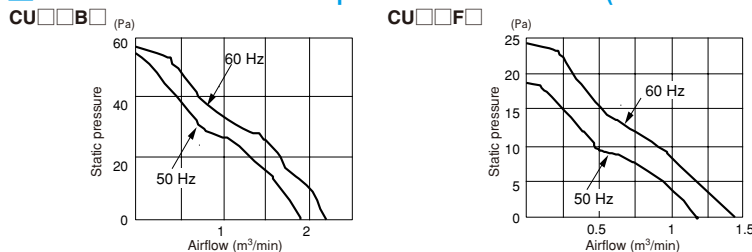

External dimensions in mm (inches)

● Lead wire type (CU□□□5)

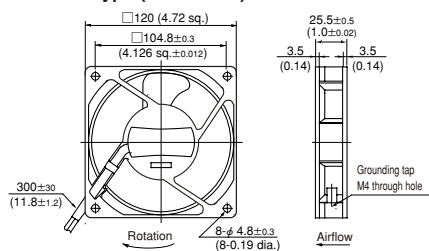

Lead wire specification
CUJ series: Heat resistant PVC 0.75 mm² (30 conductors, 0.18 dia.)
CU series: AWG22 UL1015

● Terminal type

[2 terminals: with grounding tap](CU□□□3)

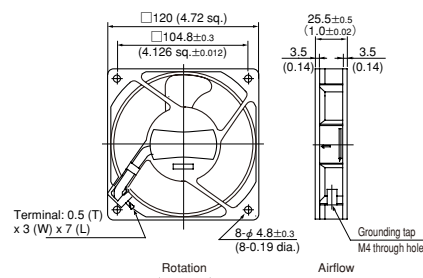

Mounting hole dimensions in mm (inches)
[Recommendation]

Options (sold separately)

- Guard: F120UL guard
- Filter: F120 filter
- Power code: T2P1 code, D2P1 code, UL2P1 code

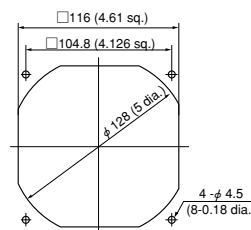

Identical for the intake and outlet sides

Fans & Blowers

Axial

DC fans

Centrifugal

Silent

AC fans

Axial

Centrifugal

Option

AC Axial Fan
CN



□ 120 × 38 (□ 4.7" × 1.5")
Max. airflow: 2.6 m³/min (50 Hz)
3.0 m³/min (60 Hz)
Max. static pressure:
83 Pa (50 Hz) 88 Pa (60 Hz)
Mass: 500 g

Fan model code

CN115B5

CN2B2

CN2B3

CN2B5

CN47D2

CN47D3

CN47D5

CN48B3

CN48D3

CN48D5

CN50B5

CN52B2

CN52B3

CN52B5

CN55B2

CN55B3

CN55B5

CN60B2

CN60B3

CN60B5

CNJ47D5

CNJ48D5

CNJ55B5

CNJ60B5

Standard specification

(Input and current are indicated on name plate)

Max. Airflow m ³ /min	Max. Static Pressure CFM Pa	Noise inH ₂ O dB	Speed min ⁻¹	Rated Vol. V (±10%)	Freq. Hz	Input W	Current mA	Lock Current mA	Model Code				
									Lead Wire Type	Std*	Terminal Type (*)	Std*	
2.6/ 3.0	92/ 106	83/ 88	0.33/ 0.35	44/ 48	2800/ 3200	50/ 60	14/12 15/13	200/180 200/180	300/270 300/270	CN55B5	UC	CN55B3, CN55B2	UCP
										CNJ55B5	P		
										CN60B5	UC	CN60B3, CN60B2	UCP ^(*)
										CNJ60B5	P		
										CN2B5	UC	CN2B3, CN2B2	UCP
										CN52B5	UC	CN52B3, CN52B2	UCP ^(*)
2.4/ 2.8	85/ 99	74/ 84	0.30/ 0.34	43/ 47	2700/ 3150	50/ 60	11/10 13/13	150/130 100/90	210/180 130/120	CN115B5	UCT		
										CN50B5	UCT		
1.6/ 1.6	56/ 56	23/ 24	0.09/ 0.10	33/ 35	1700/ 1800	50/ 60	9/8.5 8.5/8	110/100 110/100	110/100 110/100	CN47D5	UCT	CN47D3, CN47D2	UCP
										CNJ47D5	P		
										CN48D5	UCT	CN48D3	UCP
										CNJ48D5	P		

- Figures in the table are average measured values. Please request the product delivery specification when preparing a purchase specification.
 - *The symbols in the standards column denote that they are registered in the following standards files, U: UL E48889, C: CSA LR49399, LR108118 T: TUV R60229-60302
 - *Products conforming to the specifications of the Electrical Appliance and Material Safety Law (Japan) can be used in case the products are assembled in electric appliances used in Japan. (Products marked with the (PS)E mark)
- (Note) Since CN60B2, and CN52B2, do not have a ground terminal, they are not products conforming to the specifications of the Electrical Appliance and Material Safety Law (Japan)

General specification

Materials Used	Venturi: Aluminum alloy die casting Propeller: Glass fiber reinforced polycarbonate resin Bearing: Double - sided shielded ball bearing
Motor	Shaded pole induction motor Protection type: Impedance protection
Common Elec. Spec.	See page G-12.
Usage Range	Rated voltage ±10 %
Operating Temp. Range	-20 °C ~ +60 °C (-20 °C ~ +55 °C in TÜV standard)
Standard Carton	20 to a carton of (450 x 380 x 160) mm, mass 11 kg

Standard airflow and static pressure characteristics (At rated voltage)

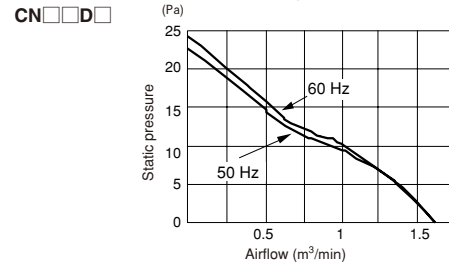
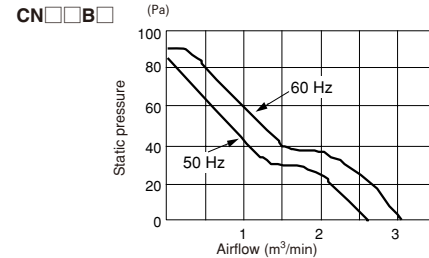

External dimensions in mm (inches)

Lead wire type (CN□□□5)

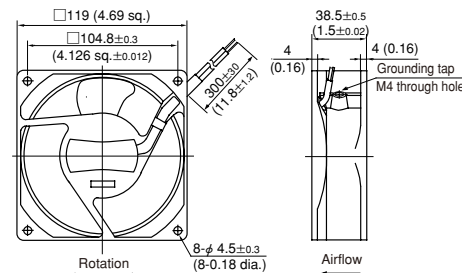

Lead wire specification
CNJ series: Heat resistant PVC 0.75 mm² (30 conductors, 0.18 dia.)
CN series: AWG22 UL1015

Mounting hole dimensions in mm (inches)
[Recommendation]

Options (sold separately)

- Guard: F120UL guard
- Filter: F120 filter
- Power code: T2P1 code, D2P1 code, UL2P1 code (for 2 terminals)
D3P1 code, UL3P1 code (for 3 terminals)

Terminal type
[2 terminals: without grounding tap] (CN□□□2)
[3 terminals: with grounding tap] (CN□□□3)

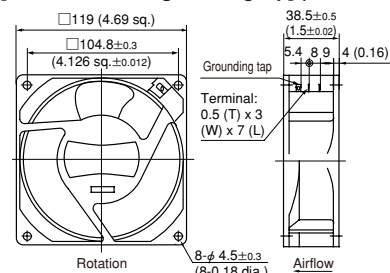

(Note) There is no grounding tap for CN series terminal type.

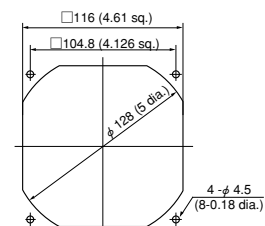

Identical for the intake and outlet sides

AC Axial Fan

MA



$\phi 172 \times 150 \times 51$
($\phi 6.8'' \times 6.0'' \times 2.0$)

Max. airflow: 5.5 m³/min (50 Hz)
6.5 m³/min (60 Hz)

Max. static pressure:
152 Pa (50 Hz) 186 Pa (60 Hz)
Mass: 950 g

Fan model code

MA2B3

MA47B3

MA48B3

MA55B3

MA60B3

MA77B3

Standard specification

(Input and current are indicated on name plate)

Max. Airflow m ³ /min	Max. Static Pressure CFM	Pa	inH ₂ O	Noise dB	Speed min ⁻¹	Rated Vol. V (±10%)	Freq. Hz	Input W	Current mA	Lock Current mA	Model Code	
											Terminal Type	Standard*
5.5/ 6.5	194/ 229	152/ 186	0.61/ 0.75	50/ 55	2850/ 3400	100	50/ 60	32/28	400/310	620/600	MA55B3	UCP
											MA2B3	UCP
											MA60B3	UCP
											MA77B3	UCP
											MA47B3	UCP
											MA48B3	UCP

- Figures in the table are average measured values. Please request the product delivery specification when preparing a purchase specification.
- *The symbols in the standards column denote that they are registered in the following standards files, U: UL E48889, C: CSA LR49399
- *Products conforming to the specifications of the Electrical Appliance and Material Safety Law (Japan) can be used in case the products are assembled in electric appliances used in Japan. (Products marked with the (PS)E mark)

General specification

Material used	Venturi: Aluminum alloy die casting Propeller: ABS and PBT synthetic resins Capacitor cover: Glass fiber reinforced polycarbonate resin Capacitor: MF capacitor Bearing: Double - sided shielded ball bearing
Motor	Capacitor phase advancing type induction motor Protection type: Thermal protection
Common Elec. Spec.	See page G-12.
Usage Range	Rated voltage ±10 %
Operating Temp. Range	-20 °C ~ +60 °C
Standard Carton	12 to a carton of (380 x 370 x 190) mm, mass 12.0 kg

Standard airflow and static pressure characteristics (At rated voltage)

MA□B3

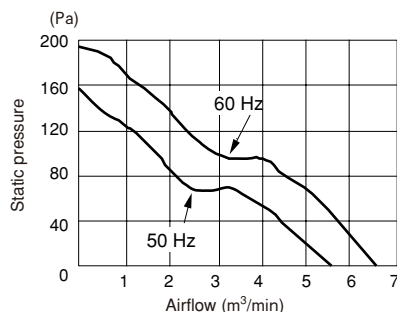

External dimensions in mm (inches)

● Terminal type

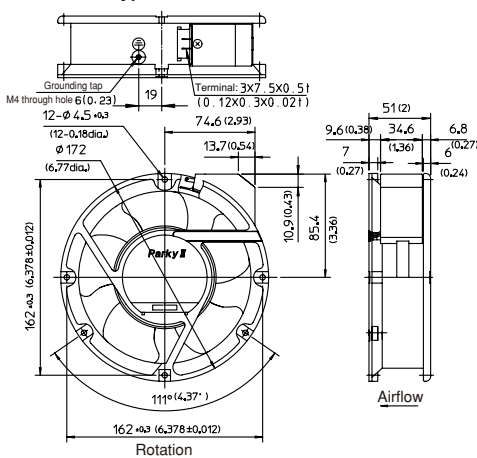

Options (sold separately)

- Guard: GUARD 172
- Power code: T2P1 code, D2P1 code, UL2P1 code

Mounting hole dimensions in mm (inches)
[Recommendation]

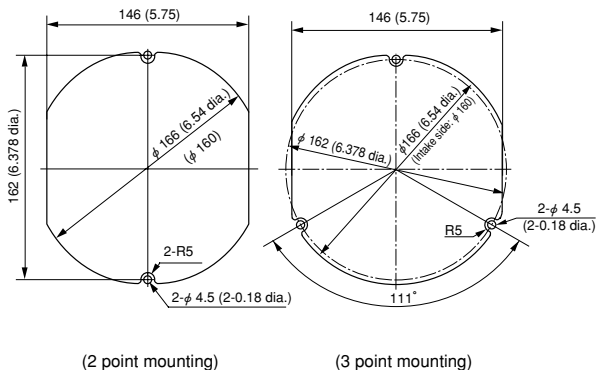

AC Axial Fan
PA



$\phi 172 \times 51$ ($\phi 6.8" \times 2.0"$)
 Max. airflow: 5.5 m³/min (50 Hz)
 6.5 m³/min (60 Hz)
 Max. static pressure:
 152 Pa (50 Hz) 186 Pa (60 Hz)
 Mass: 950 g

Fan model code

PA2B3M2

PA47B3M2

PA48B3M2

PA55B3M2

PA55H3M2

PA60B3M2

PA77B3M2

Standard specification

(Input and current are indicated on name plate)

Max. Airflow		Max. Static Pressure		Noise	Speed	Rated Vol. V ($\pm 10\%$)	Freq. Hz	Input W	Current mA	Lock Current mA	Model Code	
m ³ /min	CFM	Pa	inH ₂ O	dB	min ⁻¹						Terminal Type	Standard*
5.5/ 6.5	194/ 229	152/ 186	0.61/ 0.75	46/ 50	2850/ 3400	100	50/ 60	32/28	400/310	620/600	PA55B3	UCP
						115		29/28	270/250	470/460	PA2B3	UCP
						200		32/28	200/150	300/300	PA60B3	UCP
						220-240/ 208-230		33/30	150/130	250/240	PA77B3	UCP
						100-120		33/32	300/270	440/430	PA47B3	UCP
						200-240		33/32	150/140	240/240	PA48B3	UCP
4.7/4.7	166/166	90/75	0.36/0.30	44/44	2500/2500	100	17/19	180/200		PA55H3	UP	

- Figures in the table are average measured values. Please request the product delivery specification when preparing a purchase specification.
- *The symbols in the standards column denote that they are registered in the following standards files. U: UL E48889, C: CSA LR49399
- *Products conforming to the specifications of the Electrical Appliance and Material Safety Law (Japan) can be used in case the products are assembled in electric appliances used in Japan. (Products marked with the (PS)E mark)

General specification

Material Used	Venturi: Aluminum alloy die casting Propeller: ABS and PBT synthetic resins Capacitor cover: Glass fiber reinforced polycarbonate resin Capacitor: MF capacitor Bearing: Double - sided shielded ball bearing
Motor	Capacitor phase advancing type induction motor Protection type: Thermal protection
Common Elec. Spec.	See page G-12.
Usage Range	Rated voltage $\pm 10\%$
Operating Temp. Range	-20 °C ~ +60 °C
Standard Carton	12 to a carton of (420 x 410 x 220) mm, mass 12.5 kg

Standard airflow and static pressure characteristics (At rated voltage)

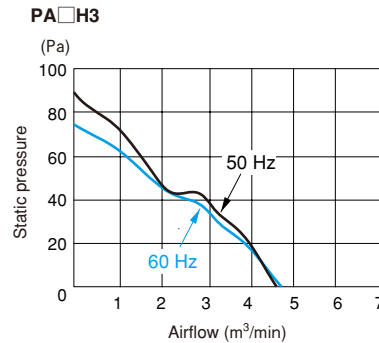
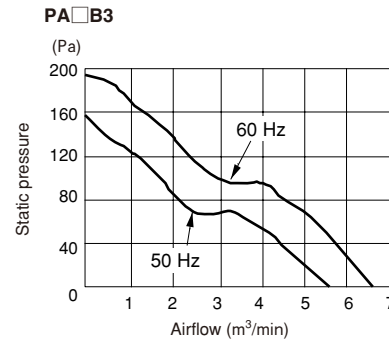

External dimensions in mm (inches)

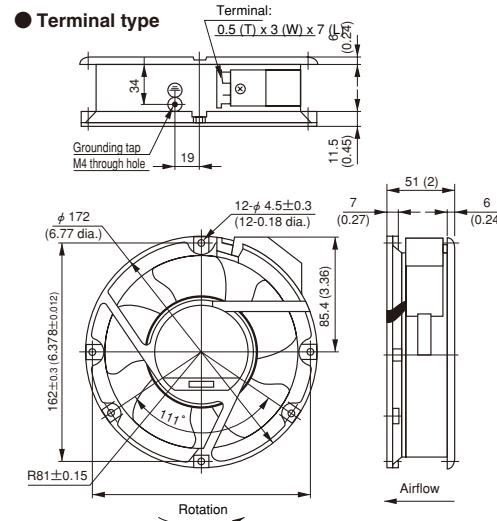

Options (sold separately)

- Guard: GUARD 172
- Power code: T2P1 code, D2P1 code, UL2P1 code

Mounting hole dimensions in mm (inches) [Recommendation]

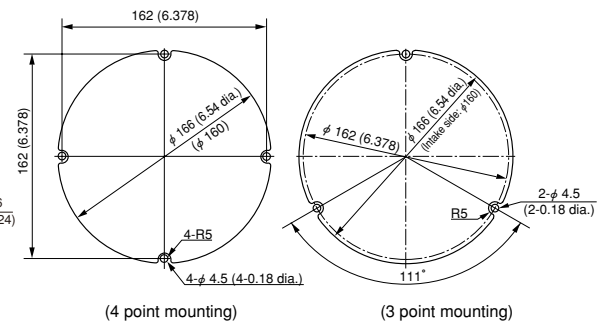

AC Axial Fan
PL



□ 180 × 90 (□ 7.1" × 3.5")
 Max. airflow: 10.8 m³/min (50 Hz)
 12.2 m³/min (60 Hz)
 Max. static pressure:
 176 Pa (50 Hz) 216 Pa (60 Hz)
 Mass: 2200 g

Fan model code

- PL2B31
- PL2B31-EX
- PL2B31S
- PL52B31
- PL52B31-EX
- PL52B31S
- PL55B31
- PL55B31-EX
- PL55B31S
- PL60B31
- PL60B31-EX
- PL60B31S
- PL74B31
- PL74B31S

Standard specification

(Input and current are indicated on name plate)

Max. Airflow		Max. Static Pressure		Noise dB	Speed min ⁻¹	Rated Vol. V (±10%)	Freq. Hz	Input W	Current mA	Lock Current mA	Model Code			
m ³ /min	CFM	Pa	inH ₂ O								Terminal Type	Standard*	Internal Capacitor Type	
10.8/ 12.2	381/ 431	176/ 216	0.71/ 0.87	59/ 61	2750/ 3050	100	50/ 60	60/75	650/780	1160/1160	PL55B31		PL55B31-EX	
									560/680	1000/1000			PL60B31	PL60B31-EX
									330/390	560/580			PL2B31	PL2B31-EX
									310/390	520/530			PL52B31	PL52B31-EX
									200 / 200-208	3 φ 50/60			60/75	210/220

- Figures in the table are average measured values. Please request the product delivery specification when preparing a purchase specification.
- *The symbols in the standards column denote that they are registered in the following standards files, U: UL E48889, C: CSA LR49399
- The life expectancy of PL series products at rated voltage and in continuous operation is 30,000 hours at 60 °C.

General specification

Material Used	Venturi: Aluminum alloy die casting, Black baking paint Propeller: Polycarbonate resin Bearing: Ball bearing Connector box: Polycarbonate
Motor	Capacitor phase advancing type induction motor and 3-phase induction motor Protection type: Thermal protection
Common Elec. Spec.	See page G-12.
Usage Range	Rated voltage ±10%
Operating Temp. Range	-20 °C ~ +60 °C
Standard Carton	5 to a carton of (470 x 435 x 215) mm, mass 12 kg

Wiring connection diagram

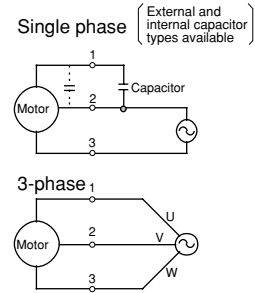

Standard airflow and static pressure characteristics (At rated voltage)

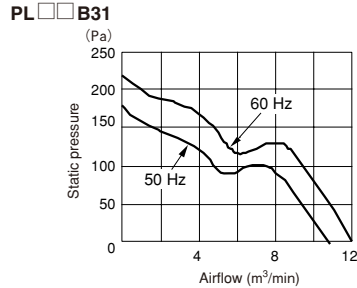

Capacitor (Normally included)

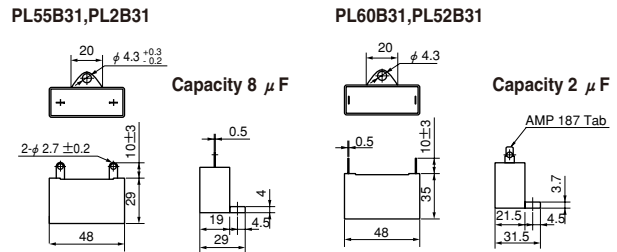

External dimensions in mm (inches)

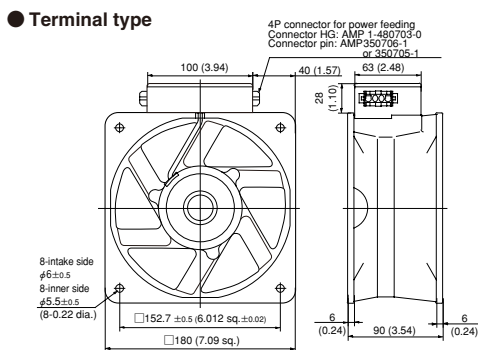

Mounting hole dimensions in mm (inches)
[Recommendation]

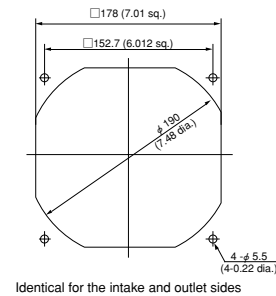

AC axial fan with sensor

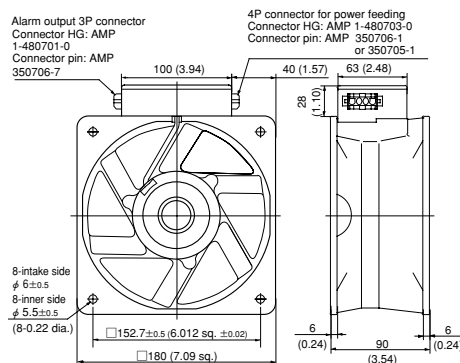

Mating model code

Rated Voltage V (±10%)	Model Code	Standard*
100	PL55B31S	
200	PL60B31S	
115	PL2B31S	
208-230	PL52B31S	
3-phase 200/200-208	PL74B31S	UCT

T: TUV FILE No.9051212

Options (sold separately)

- Guard: F180UL guard
- Power code: PL4P1 code
- Sensor code: PL sensor 1 code

Fans & Blowers

Axial

DC fans

Centrifugal

Silent

AC fans

Axial

Centrifugal

Option

AC Centrifugal Blower

CB



125×126×41

(4.9"×5.0"×1.6")

Max. airflow: 0.65 m³/min (50 Hz)
0.7 m³/min (60 Hz)

Max. static pressure:
88 Pa (50 Hz) 127 Pa (60 Hz)
Mass: 570 g

Fan model code

CB2B4

CB52B3

CB52B4

CB55B3-Y

CB55B4-Y

CB60B3

CB60B4

Standard specification

(Input and current are indicated on name plate)

Max. Airflow		Max. Static Pressure		Noise dB	Speed min ⁻¹	Rated Vol. V (±10 %)	Freq. Hz	Input W	Current mA	Lock Current mA	Model Code			
m ³ /min	CFM	Pa	inH ₂ O								Lead Wire Type	Standard*	Terminal Type	Standard*
0.65/ 0.70	23/ 25	88/ 127	0.35/ 0.51	53/ 55	2600/ 2850	100	50/ 60	18.5/17	220/210	300/260	CB55B4-Y	UC	CB55B3-Y	UCP
								15/15	150/140	200/170	CB60B4	UC	CB60B3	UCP
								17/16	280/245	380/330	CB2B4	UC		
								17.5/16.5	180/145	230/200	CB52B4	UC	CB52B3	UCP

- Figures in the table are average measured values. Please request the product delivery specification when preparing a purchase specification.
- *The symbols in the standards column denote that they are registered in the following standards files, U: UL E48889, C: CSA LR49399, LR: LR108118
- *Products conforming to the specifications of the Electrical Appliance and Material Safety Law (Japan) can be used in case the products are assembled in electric appliances used in Japan. (Products marked with the (PSE) mark)

General specification

Material Used	Housing: Aluminum alloy die casting Impeller: Polycarbonate resin Bearing: Double - sided shielded ball bearing Inlet cover: Aluminum board or Galvanized steel sheet Terminal: Brass, tin plating
Motor	Shaded pole induction motor Protection type: Impedance protection
Common Elec. Spec.	See page G-12.
Usage Range	Rated voltage ±10 %
Operating Temp. Range	- 20 °C ~ + 60 °C

Standard airflow and static pressure characteristics (At rated voltage)

CB□□B□

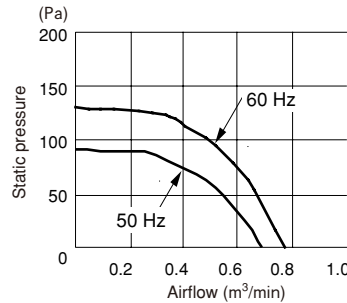

External dimensions in mm (inches)

● Lead wire type (CB□□4)

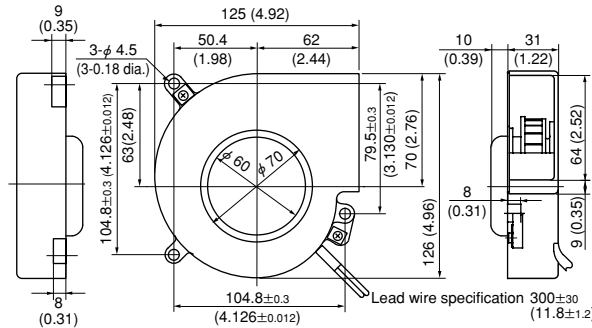

Lead wire specification: AWG22 UL1015

● Terminal type (CB□□3)

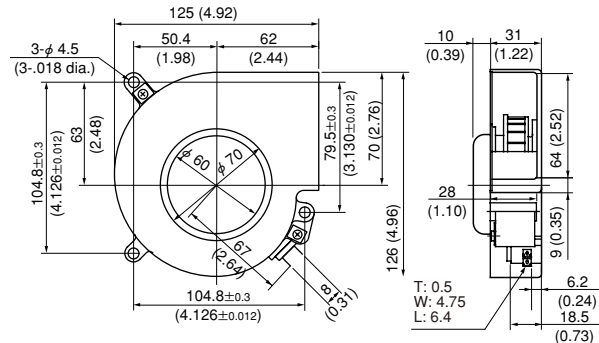

F60P Guard (Mass 4 g)

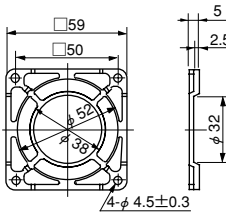

Material: Polycarbonate (black)
UL94V-2

F60UL Guard (Mass 12 g)

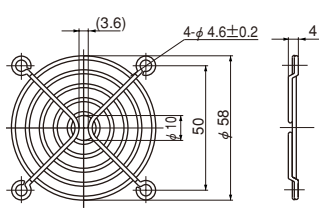

Material: Mild steel wire 1.6 dia.
Surface treatment:
Nickel chromium plating

F80UL Guard (Mass 14 g)

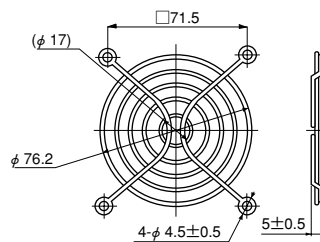

Material: Mild steel wire 1.6 dia.
Surface treatment:
Nickel chromium plating

F92UL Guard (Mass 16 g)

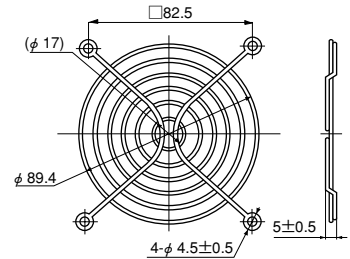

Material: Mild steel wire 1.6 dia.
Surface treatment:
Nickel chromium plating

F120UL Guard (Mass 29 g)

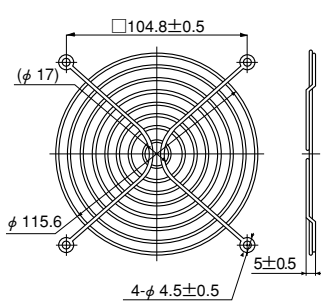

Material: Mild steel wire 1.6 dia.
Surface treatment:
Nickel chromium plating

F127UL Guard

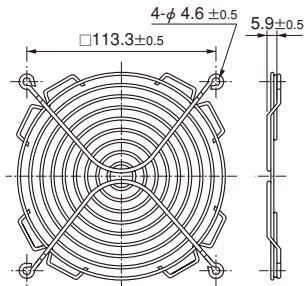

Material: Mild steel wire 1.6 dia.
Surface treatment:
Nickel chromium plating

GUARD 172

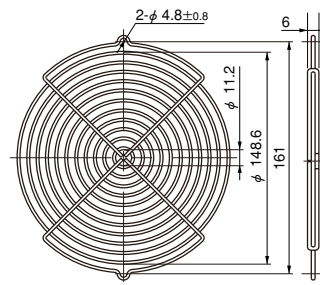

Material: Mild steel wire 2 dia.
Surface treatment:
Nickel chromium plating

F180UL Guard

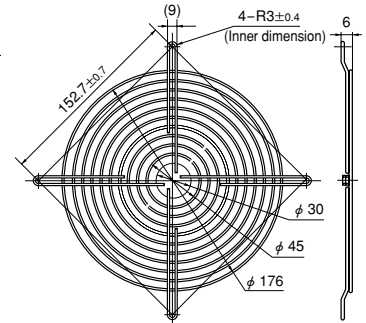

Material: Mild steel wire 1.6 dia.
Surface treatment:
Nickel chromium plating

F200UL Guard (Mass 82 g)

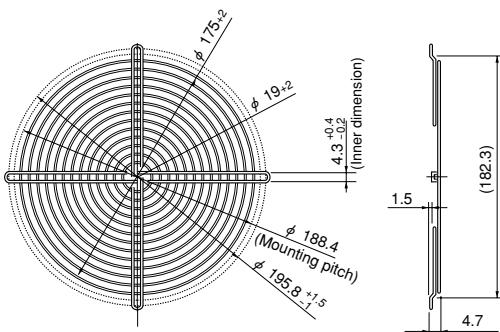

Material: Mild steel wire 1.6 dia.
Surface treatment:
Nickel chromium plating

SCU Guard (Mass 50 g)

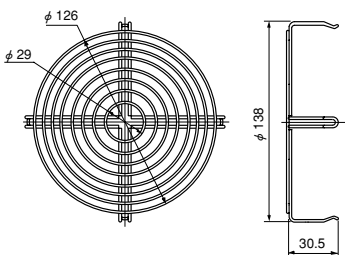

Material: Mild steel wire 1.6 dia.
Surface treatment:
Nickel chromium plating

SCN Guard (Mass 55 g)

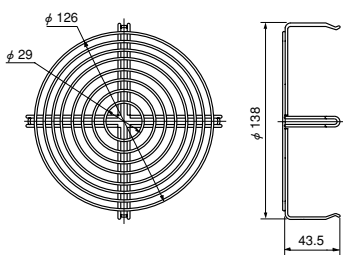

Material: Mild steel wire 1.6 dia.
Surface treatment:
Nickel chromium plating

• Guard special for intake side of SCUD (metal venturi) fans.

• Guard special for intake side of SCND (metal venturi) fans.

List of mating fan series

Guard	F60P	F60UL	F80UL	F92UL	F120UL	F127UL	GUARD 172	F180UL	F200UL	SCN	SCU
SCU					○*1						○*2
SCN					○*1					○*2	
VE			○								
WE				○							
KA				○							
CU					○						
CN					○						
MA								○			
PA								○			
PL									○		
TUDC	○	○									
PUDC			○								
KUDC				○							
DO925C				○							
KLDC				○							
CUDC					○						
D1225C					○						
CNDC					○						
D1238T					○						
D1238B					○						
D1338B						○					
D1338S						○					
D1751M							○				
D1751S							○				
G0638D		○									
B0838C			○								
G0938B				○							
G1238B					○				○		
G1751M								○			

*1: Can be installed only on outlet side. *2: Can be installed only on intake side.
All guards conform to the UL standard when combined with NIDEC SERVO fans.
The installation of a filter, guard and other accessories will constitute a ventilating load, reducing the airflow. Select a suitable guard, taking into consideration the increase in air resistance. (See Figs. 12 and 13 on page G-7.)

Filter

3-piece set

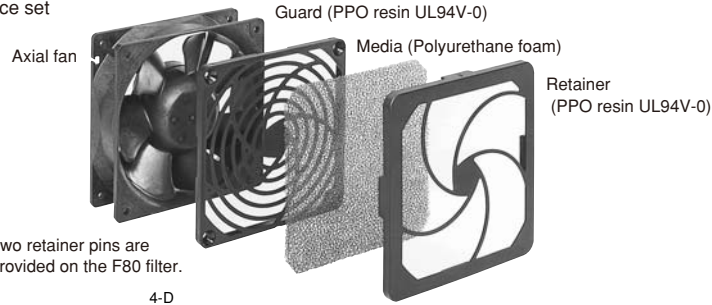

Note: Two retainer pins are provided on the F80 filter.

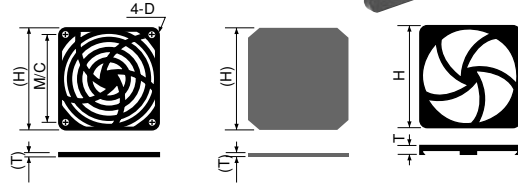

List of mating fan series

Filter	F80	F92	F120
PUDC	○		
KUDC		○	
D0925C		○	
KLDC		○	
CUDC			○
D1225C			○
CNDC			○
D1238T			○
D1238B			○
G0838C	○		
G0938B		○	
G1238B			○

Filter	F80	F92	F120
VE	○		
WE		○	
KA		○	
CU			○
CN			○

Component (Model Code)	H	T	M/C	D
F80 Filter	83.6	10	71.5	φ 3.8
F92 Filter	96.5	10	82.5	φ 3.8
F120 Filter	123.7	10.7	104.8	φ 4.6

Flange spacer

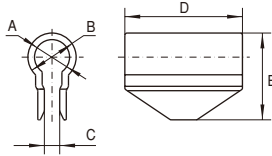

Component (Model Code)	A mm	B mm	C mm	D mm	E mm	Mating Model Code
Flange Spacer PUDC (※)	5	8	2	17	14.5	KUDC,PUDC
Flange Spacer CUDC (※)	8	11	3.5	15	19.8	CUDC
Flange Spacer CNDC	8	11	3.5	28	19.8	CNDC

※Ribbed venturis (PUDC-R, CUDC-R) are available for PUDC and CUDC.

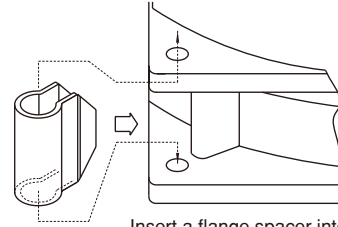

Insert a flange spacer into the ribs of a venturi.

(Installing a flange spacer)

Inlet ring

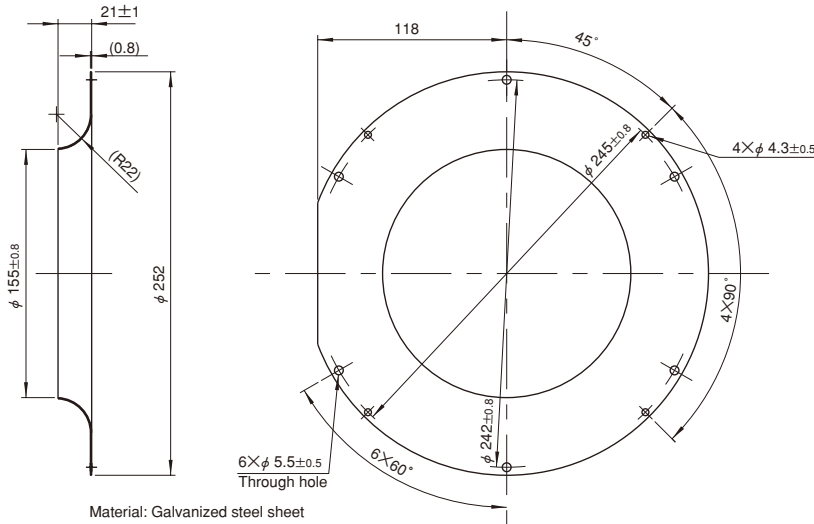

Material: Galvanized steel sheet

Component (Model Code)	Mating Model Code
E2271 Inlet ring	E2271Z

Plug cords for AC fans

(Common specification: Rated 3 A, voltage 250 V, dielectric strength 1 minute at 1500 V 50 Hz)

D2P1 cord (Mass 35 g)

Certified under the Electrical Appliance and Material Safety Law (Japan) (<PS>E mark approved)
Cord 0.18 dia. 30 conductors Black, heat resistant vinyl

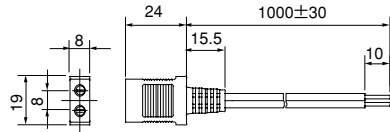

UL2P1 cord (Mass 41 g)

UL standard product (UL file No. E78112)
Cord 0.16 dia. 41 conductors Black, heat resistant vinyl

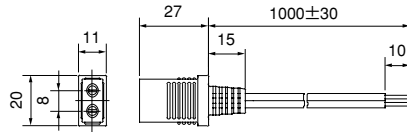

* UL2P2 cord with 2m length also available.

T2P1 cord

For wiring inside equipment
Cord 0.18 dia. 30 conductors Black, heat resistant vinyl

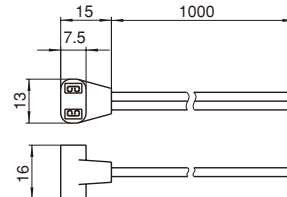

* T2PZ cord with 2m length also available.

D3P1 cord (Mass 59 g)

Certified under the Electrical Appliance and Material Safety Law (Japan) (<PS>E mark approved)
Cord:

For power feeding 0.18 dia. 30 conductors Black, heat resistant vinyl
For grounding 0.18 dia. 50 conductors Black, heat resistant vinyl

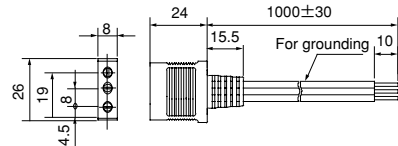

UL3P1 cord (Mass 60 g)

UL standard product (UL file No. E78112)
Cord:

For power feeding 0.16 dia. 41 conductors Black, heat resistant vinyl
For grounding AWG18 green/yellow spiral, heat resistant vinyl

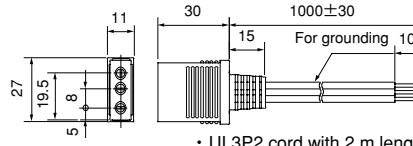

* UL3P2 cord with 2 m length also available.

PL sensor 1 cord

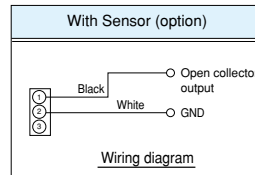
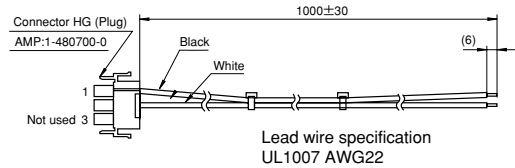

PL4P1 cord

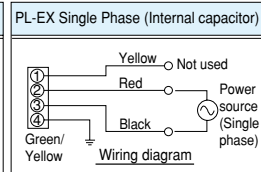
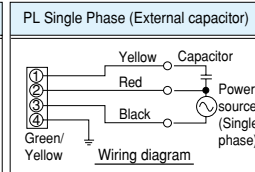
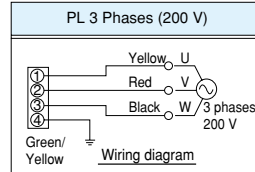
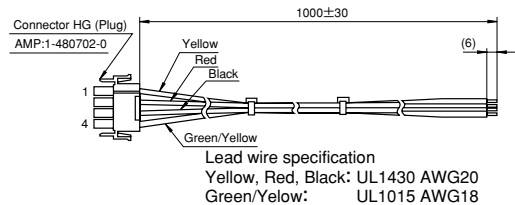

List of mating fan series

Cord	T2P1	T2P2	D2P1	D3P1	UL2P1	UL3P1	PL4P1	PL sensor
WE	○	○	○		○			
KA	○	○	○		○			
CU	○	○	○		○			
CN (2 terminals)	○	○	○		○			
CN (3 terminals)				○		○		
MA	○	○	○		○			
PA	○	○	○		○			
PL							○	○

Plug cords for DC fans

DCLD030ST-ZZ01 (S sensor output cord)

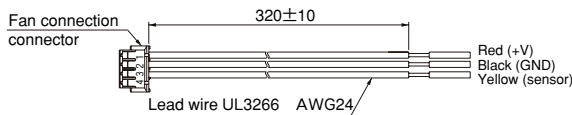

DCLD030PT-ZZ01 (P sensor output cord)

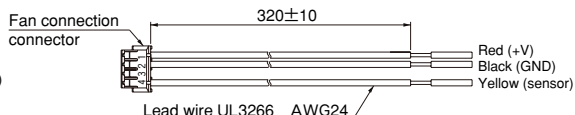

• Lead wire ends are sheathed to protect conductors. (Sheath peeling dimension 10±5)

Component (Model Code)	Mating Model Code
DCLD030ST-ZZ01	E1033H□□B□AM-04
DCLD030PT-ZZ01	



NIDEC SERVO CORPORATION
INTERNATIONAL SALES OFFICE
Osaki MT Bldg. 2F, 5-9-11 Kita-Shinagawa,
Shinagawa-ku, Tokyo, 141-0001
TEL: +81-(0)3-6756-5304 FAX: +81-(0)3-6702-0507

NIDEC SERVO AMERICA CORPORATION
2050 Center Ave. Suite 318 Fort Lee, NJ 07024 USA
TEL +1-(0)201-585-0720 FAX: +1-(0)201-585-0670

NIDEC SERVO EUROPE B.V.
Johanniterlaan 8, 3841 DT Harderwijk, The Netherlands
PO Box 1099, 3840 BB Harderwijk, The Netherlands
TEL: +31-(0)3414-27575 FAX: +31-(0)3414-23388

PO Box 7084, Hook, Hampshire, RG27 9XL, UK
TEL: +44-(0)1256-767712 FAX: +44-(0)1256-767715

NIDEC SERVO CORPORATION SINGAPORE BRANCH
No. 50, Kallang Avenue, #05-01,
Noel Corporate Building, Singapore 339505
TEL: +65-(0)6743-7655 FAX: +65-(0)6842-7839

NIDEC SERVO (HONG KONG) CO., LIMITED
Unit 1008-09, Saxon Tower, 7 Cheung Shun Street,
Lai Chi Kok, Kowloon, Hong Kong
TEL: +852-(0)2314-0037 FAX: +852-(0)2314-4768

NIDEC SERVO (HONG KONG) CO., LIMITED
TAIWAN REPRESENTATIVE OFFICE
Room 1001, No. 88, Sec. 2, Chung Hsiao East Road,
Taipei, Taiwan
FAX: +852-(0)3007-8924

WARNING

- Please do not exceed the specifications noted in this catalogue, otherwise there is a chance of electric shock, injury, or other damage.
- Please do not insert your fingers or any other object into the fan's interior, otherwise there is a chance of electric shock, injury, or fire.
- Any modifications made to this fan are beyond the limits of our guarantee. NIDEC SERVO cannot take responsibility for any customer modifications.
- Please ensure that a thorough evaluation has been done before using this fan in medical equipment or other devices related to human lives.
- Please ensure that a thorough evaluation has been done before using this fan in applications that have a serious effect on the public.

NOTE

- Figures in this catalogue are average measured values. Please request the product delivery specification when preparing a purchase specification.
- The dimensions, specifications, and components contained in this catalogue are subject to change without prior notice due to further product improvements.