

NH fuse-links gG 500VAC

double indicator/isolated gripping-lugs size 000, 00, 0, 1, 2, 3

LOW VOLTAGE IEC FUSES

IEC NH FUSE-LINKS



The NH system is classified among plug-in fuse systems and is composed of:

- fuse-base (possibly including terminal covers and phase barriers)
- fuse-link with blade contact
- fuse-link replacement device (LV HRC fuse puller)

Since the design of this system cannot guarantee non-interchangeability of rated current it must be handled by a qualified professional.

Type “gG” NH fuse-links are full range breaking capacity fuse-links and are used to protect cables and equipment. They can interrupt any current surge, from the lowest fusing current up to their breaking capacity, and so can be used alone as protection. They also protect electrical devices and industrial set-ups from the electrodynamic effects of very high short-circuit currents.

TECHNICAL DATA OVERVIEW

Voltage AC	500 VAC
Voltage DC	250 VDC
Ampere Range (A)	2 ... 630 A
Size per Standard	Size 000 to 3
Speed/Characteristic	gG
I.R. AC (IEC)	120 kA
I.R. DC (IEC)	80 kA
Body Material	ceramic
Contact Materials	copper, silver-plated

FEATURES & BENEFITS

- Dimensions according to DIN 43 620 Parts 1 to 4
- Isolated metal gripping lugs (SGL)
- Double indicator
- Lead free contact blades
- 0% cadmium

APPLICATIONS

- gG: general purpose cable and line protection

STANDARDS

- VDE 0636 Part 201
- IEC 60269-1 and -2



MERSEN reserves the right to change, update or correct, without notice, any information contained in this datasheet.

NH fuse-links gG 500VAC

double indicator/isolated gripping-lugs size 000, 00, 0, 1, 2, 3

PRODUCT RANGE



NH000GG50V100-1

Size 000 gG 500VAC isolated gripping-lugs

Catalog number	Item number	Rated voltage AC (IEC)	Rated voltage DC (IEC)	Rated current I _n	Power dissipation at I _n	Width	Package	Weight
NH000GG50V2-1	C219652	500 V	250 V	2 A	1.9 W	20.8 mm	3	0.13 kg
NH000GG50V4-1	N205770	500 V	250 V	4 A	1.5 W	20.8 mm	3	0.13 kg
NH000GG50V6-1	P212464	500 V	250 V	6 A	1.6 W	20.8 mm	3	0.13 kg
NH000GG50V10-1	V215528	500 V	250 V	10 A	1.1 W	20.8 mm	3	0.13 kg
NH000GG50V16-1	F213997	500 V	250 V	16 A	1.8 W	20.8 mm	9	0.13 kg
NH000GG50V20-1	F218091	500 V	250 V	20 A	2.3 W	20.8 mm	9	0.13 kg
NH000GG50V25-1	K200638	500 V	250 V	25 A	2.4 W	20.8 mm	9	0.13 kg
NH000GG50V32-1	D213489	500 V	250 V	32 A	3.1 W	20.8 mm	9	0.13 kg
NH000GG50V35-1	G201187	500 V	250 V	35 A	3 W	20.8 mm	9	0.13 kg
NH000GG50V40-1	D219653	500 V	250 V	40 A	3.7 W	20.8 mm	9	0.13 kg
NH000GG50V50-1	C222849	500 V	250 V	50 A	4.1 W	20.8 mm	9	0.13 kg
NH000GG50V63-1	R212466	500 V	250 V	63 A	5.4 W	20.8 mm	9	0.13 kg
NH000GG50V80-1	N215016	500 V	250 V	80 A	6.5 W	20.8 mm	9	0.13 kg
NH000GG50V100-1	J201189	500 V	250 V	100 A	7.5 W	20.8 mm	9	0.13 kg



NH00GG50V160-1

Size 00 gG 500VAC isolated gripping-lugs

Catalog number	Item number	Rated voltage AC (IEC)	Rated voltage DC (IEC)	Rated current I _n	Power dissipation at I _n	Width	Package	Weight
NH00GG50V125-1	V200808	500 V	250 V	125 A	10 W	29.5 mm	3	0.2 kg
NH00GG50V160-1	W201867	500 V	250 V	160 A	12.3 W	29.5 mm	3	0.2 kg



NH0GG50V160-1

Size 0 gG 500VAC isolated gripping-lugs

Catalog number	Item number	Rated voltage AC (IEC)	Rated voltage DC (IEC)	Rated current I _n	Power dissipation at I _n	Width	Package	Weight
NH0GG50V6-1	B212636	500 V	250 V	6 A	1.6 W	29.5 mm	3	0.23 kg
NH0GG50V10-1	M213152	500 V	250 V	10 A	1.1 W	29.5 mm	3	0.23 kg
NH0GG50V16-1	E213651	500 V	250 V	16 A	1.8 W	29.5 mm	3	0.23 kg
NH0GG50V20-1	L214163	500 V	250 V	20 A	2.3 W	29.5 mm	3	0.23 kg
NH0GG50V25-1	P214672	500 V	250 V	25 A	2.4 W	29.5 mm	3	0.23 kg
NH0GG50V32-1	V215183	500 V	250 V	32 A	3.1 W	29.5 mm	3	0.23 kg
NH0GG50V35-1	W215690	500 V	250 V	35 A	3 W	29.5 mm	3	0.23 kg
NH0GG50V40-1	C216202	500 V	250 V	40 A	3.7 W	29.5 mm	3	0.23 kg
NH0GG50V50-1	A216706	500 V	250 V	50 A	4.1 W	29.5 mm	3	0.23 kg
NH0GG50V63-1	N217224	500 V	250 V	63 A	6.6 W	29.5 mm	3	0.23 kg
NH0GG50V80-1	T217735	500 V	250 V	80 A	8 W	29.5 mm	3	0.23 kg
NH0GG50V100-1	D218250	500 V	250 V	100 A	9.4 W	29.5 mm	3	0.23 kg
NH0GG50V125-1	S218769	500 V	250 V	125 A	11.8 W	29.5 mm	3	0.23 kg
NH0GG50V160-1	F219287	500 V	250 V	160 A	14.6 W	29.5 mm	3	0.23 kg

MERSEN reserves the right to change, update or correct, without notice, any information contained in this datasheet.

NH fuse-links gG 500VAC

double indicator/isolated gripping-lugs size 000, 00, 0, 1, 2, 3

PRODUCT RANGE



NH1GG50V16-1

Size 1 gG 500VAC isolated gripping-lugs

Catalog number	Item number	Rated voltage AC (IEC)	Rated voltage DC (IEC)	Rated current I _n	Power dissipation at I _n	Width	Package	Weight
NH1GG50V16-1	H219818	500 V	250 V	16 A	1.8 W	29.5 mm	3	0.28 kg
NH1GG50V20-1	T222496	500 V	250 V	20 A	2.3 W	29.5 mm	3	0.28 kg
NH1GG50V25-1	K223017	500 V	250 V	25 A	2.4 W	29.5 mm	3	0.28 kg
NH1GG50V32-1	R200805	500 V	250 V	32 A	3.1 W	29.5 mm	3	0.28 kg
NH1GG50V35-1	G201348	500 V	250 V	35 A	3 W	29.5 mm	3	0.28 kg
NH1GG50V40-1	Q211085	500 V	250 V	40 A	3.7 W	29.5 mm	3	0.28 kg
NH1GG50V50-1	L212116	500 V	250 V	50 A	4.1 W	29.5 mm	3	0.28 kg
NH1GG50V63-1	N213153	500 V	250 V	63 A	6.6 W	29.5 mm	3	0.28 kg
NH1GG50V80-1	M214164	500 V	250 V	80 A	8 W	29.5 mm	3	0.28 kg
NH1GG50V100-1	W215184	500 V	250 V	100 A	9.4 W	29.5 mm	3	0.28 kg
NH1GG50V125-1	T236043	500 V	250 V	125 A	11.8 W	29.5 mm	3	0.28 kg
NH1GG50V160-1	B216707	500 V	250 V	160 A	14.6 W	39.5 mm	3	0.42 kg
NH1GG50V200-1	P217225	500 V	250 V	200 A	18 W	39.5 mm	3	0.42 kg
NH1GG50V224-1	V217736	500 V	250 V	224 A	19 W	39.5 mm	3	0.42 kg
NH1GG50V250-1	E218251	500 V	250 V	250 A	20 W	39.5 mm	3	0.42 kg



NH2GG50V250-1

Size 2 gG 500VAC isolated gripping-lugs

Catalog number	Item number	Rated voltage AC (IEC)	Rated voltage DC (IEC)	Rated current I _n	Power dissipation at I _n	Width	Package	Weight
NH2GG50V25-1	J219819	500 V	250 V	25 A	2.4 W	39.5 mm	3	0.42 kg
NH2GG50V35-1	L223018	500 V	250 V	35 A	3 W	39.5 mm	3	0.42 kg
NH2GG50V40-1	S200806	500 V	250 V	40 A	3.7 W	39.5 mm	3	0.42 kg
NH2GG50V50-1	H201349	500 V	250 V	50 A	4.1 W	39.5 mm	3	0.42 kg
NH2GG50V63-1	T201865	500 V	250 V	63 A	6.8 W	39.5 mm	3	0.42 kg
NH2GG50V80-1	F211605	500 V	250 V	80 A	8.3 W	39.5 mm	3	0.42 kg
NH2GG50V100-1	P213154	500 V	250 V	100 A	10.7 W	39.5 mm	3	0.42 kg
NH2GG50V125-1	N214165	500 V	250 V	125 A	12.2 W	39.5 mm	3	0.42 kg
NH2GG50V160-1	X215185	500 V	250 V	160 A	15 W	39.5 mm	3	0.42 kg
NH2GG50V200-1	E216204	500 V	250 V	200 A	18.5 W	39.5 mm	3	0.42 kg
NH2GG50V224-1	Q217226	500 V	250 V	224 A	19.2 W	39.5 mm	3	0.42 kg
NH2GG50V250-1	F218252	500 V	250 V	250 A	20.6 W	39.5 mm	3	0.42 kg
NH2GG50V300-1	H219289	500 V	250 V	300 A	21 W	51 mm	3	0.64 kg
NH2GG50V315-1	K219820	500 V	250 V	315 A	25 W	51 mm	3	0.64 kg
NH2GG50V355-1	M223019	500 V	250 V	355 A	31.5 W	51 mm	3	0.64 kg
NH2GG50V400-1	T200807	500 V	250 V	400 A	28.5 W	51 mm	3	0.64 kg



NH3GG50V630-1

Size 3 gG 500VAC isolated gripping-lugs

Catalog number	Item number	Rated voltage AC (IEC)	Rated voltage DC (IEC)	Rated current I _n	Power dissipation at I _n	Width	Package	Weight
NH3GG50V250-1	J201350	500 V	250 V	250 A	21.1 W	51 mm	1	0.65 kg
NH3GG50V300-1	S211087	500 V	250 V	300 A	20 W	51 mm	1	0.65 kg
NH3GG50V315-1	G211606	500 V	250 V	315 A	25 W	51 mm	1	0.65 kg
NH3GG50V355-1	E212639	500 V	250 V	355 A	32 W	51 mm	1	0.65 kg
NH3GG50V400-1	H213654	500 V	250 V	400 A	34 W	51 mm	1	1.05 kg
NH3GG50V425-1	S214675	500 V	250 V	425 A	34 W	70 mm	1	1.05 kg
NH3GG50V450-1	Z215693	500 V	250 V	450 A	38 W	70 mm	1	1.05 kg
NH3GG50V500-1	F216205	500 V	250 V	500 A	43 W	70 mm	1	1.05 kg
NH3GG50V630-1	D216709	500 V	250 V	630 A	43.1 W	70 mm	1	1.05 kg

NH fuse-links gG 500VAC

double indicator/isolated gripping-lugs size 000, 00, 0, 1, 2, 3

TECHNICAL DATA

	Size 000	Size 00	Size 0	Size 1	Size 2	Size 3
Rated current	2 ... 100 A	125 ... 160 A	6 ... 160 A	16 ... 250 A	25 ... 400 A	250 ... 630 A
Rated breaking capacity AC	120 kA	120 kA	120 kA	120 kA	120 kA	120 kA
Rated voltage AC	500 V	500 V	500 V	500 V	500 V	500 V
Rated voltage DC	250 V	250 V	250 V	250 V	250 V	250 V
Indication System	double indicator	double indicator	double indicator	double indicator	double indicator	double indicator
Width	21 mm	30 mm	30 mm	40 mm	52 mm	72 mm

NH fuse-links gG 500VAC

double indicator/isolated gripping-lugs size 000, 00, 0, 1, 2, 3

TIME CURRENT CHARACTERISTIC CURVES

Size 000

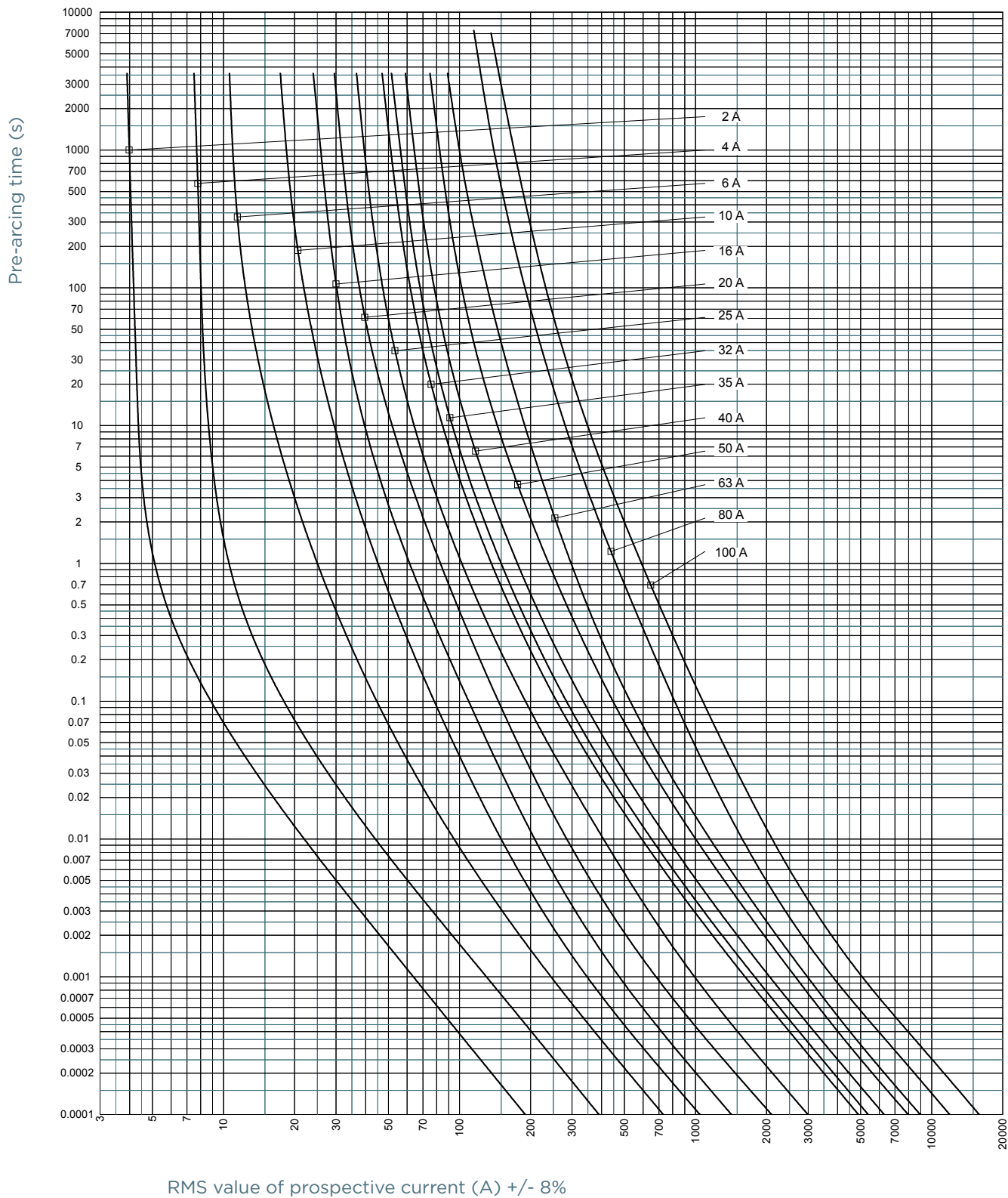

MERSEN reserves the right to change, update or correct, without notice, any information contained in this datasheet.

NH fuse-links gG 500VAC

double indicator/isolated gripping-lugs size 000, 00, 0, 1, 2, 3

TIME CURRENT CHARACTERISTIC CURVES

Size 00

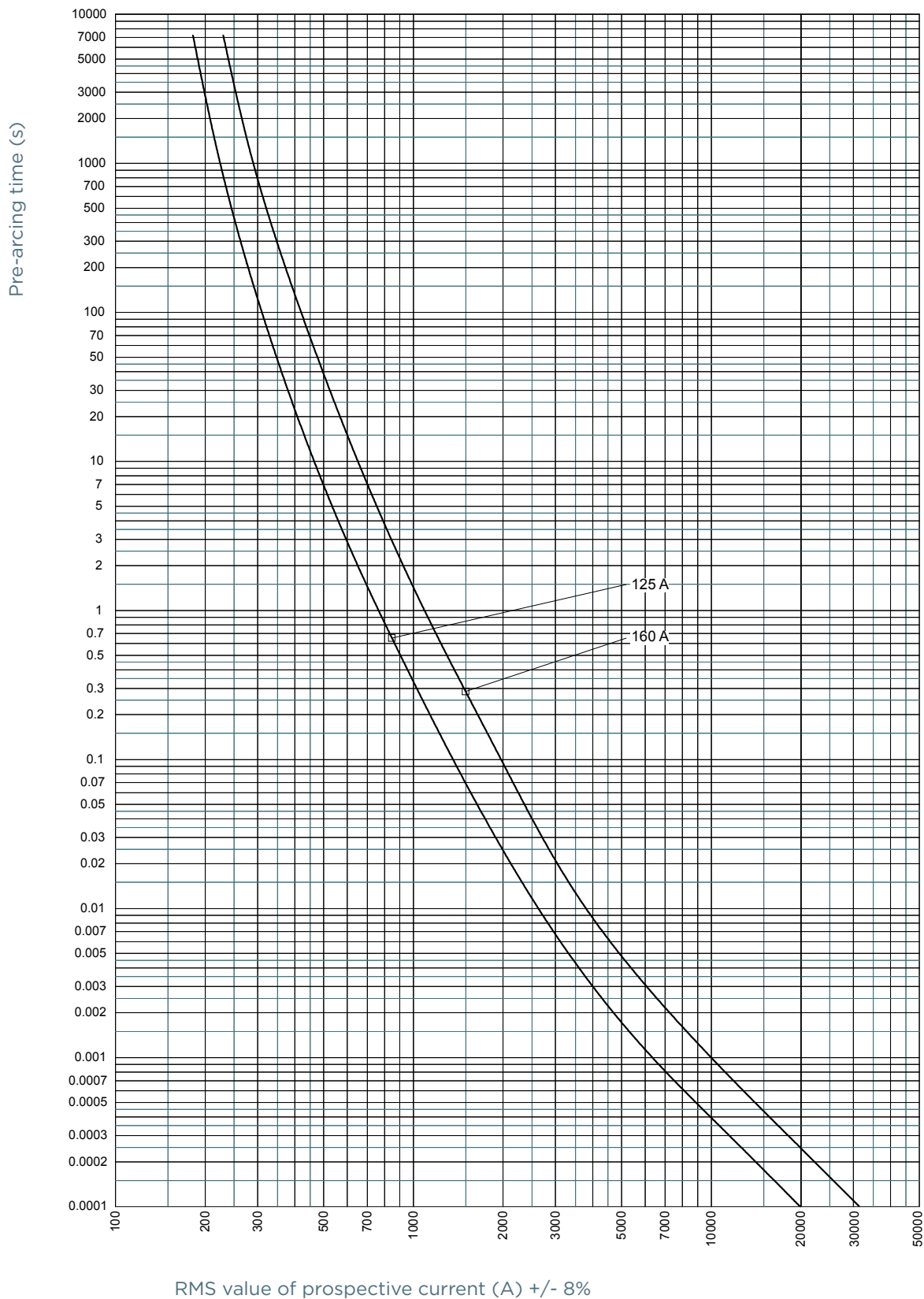

MERSEN reserves the right to change, update or correct, without notice, any information contained in this datasheet.

NH fuse-links gG 500VAC

double indicator/isolated gripping-lugs size 000, 00, 0, 1, 2, 3

TIME CURRENT CHARACTERISTIC CURVES

Size 0

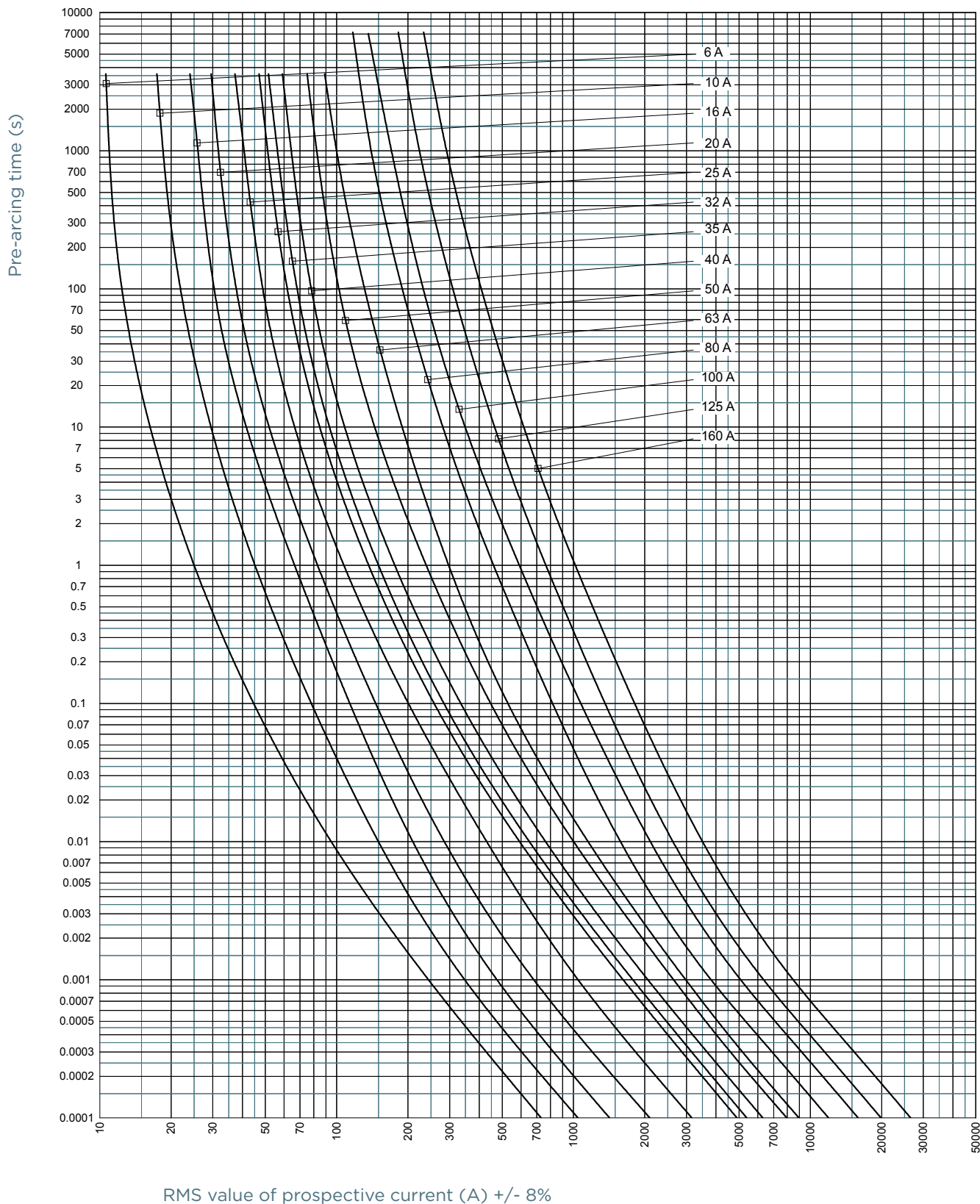

MERSEN reserves the right to change, update or correct, without notice, any information contained in this datasheet.

NH fuse-links gG 500VAC

double indicator/isolated gripping-lugs size 000, 00, 0, 1, 2, 3

TIME CURRENT CHARACTERISTIC CURVES

Size 1

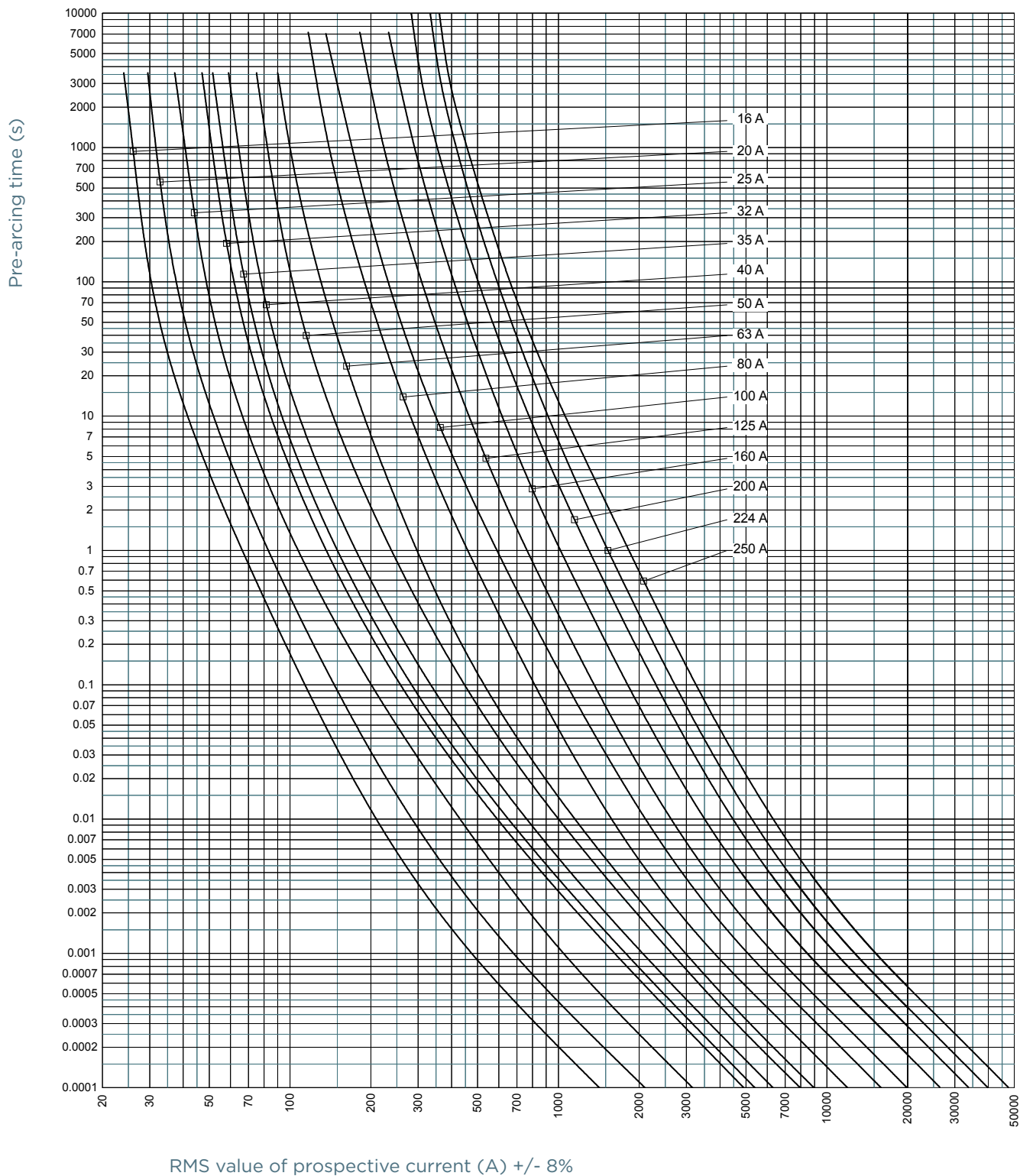

MERSEN reserves the right to change, update or correct, without notice, any information contained in this datasheet.

NH fuse-links gG 500VAC

double indicator/isolated gripping-lugs size 000, 00, 0, 1, 2, 3

TIME CURRENT CHARACTERISTIC CURVES

Size 2

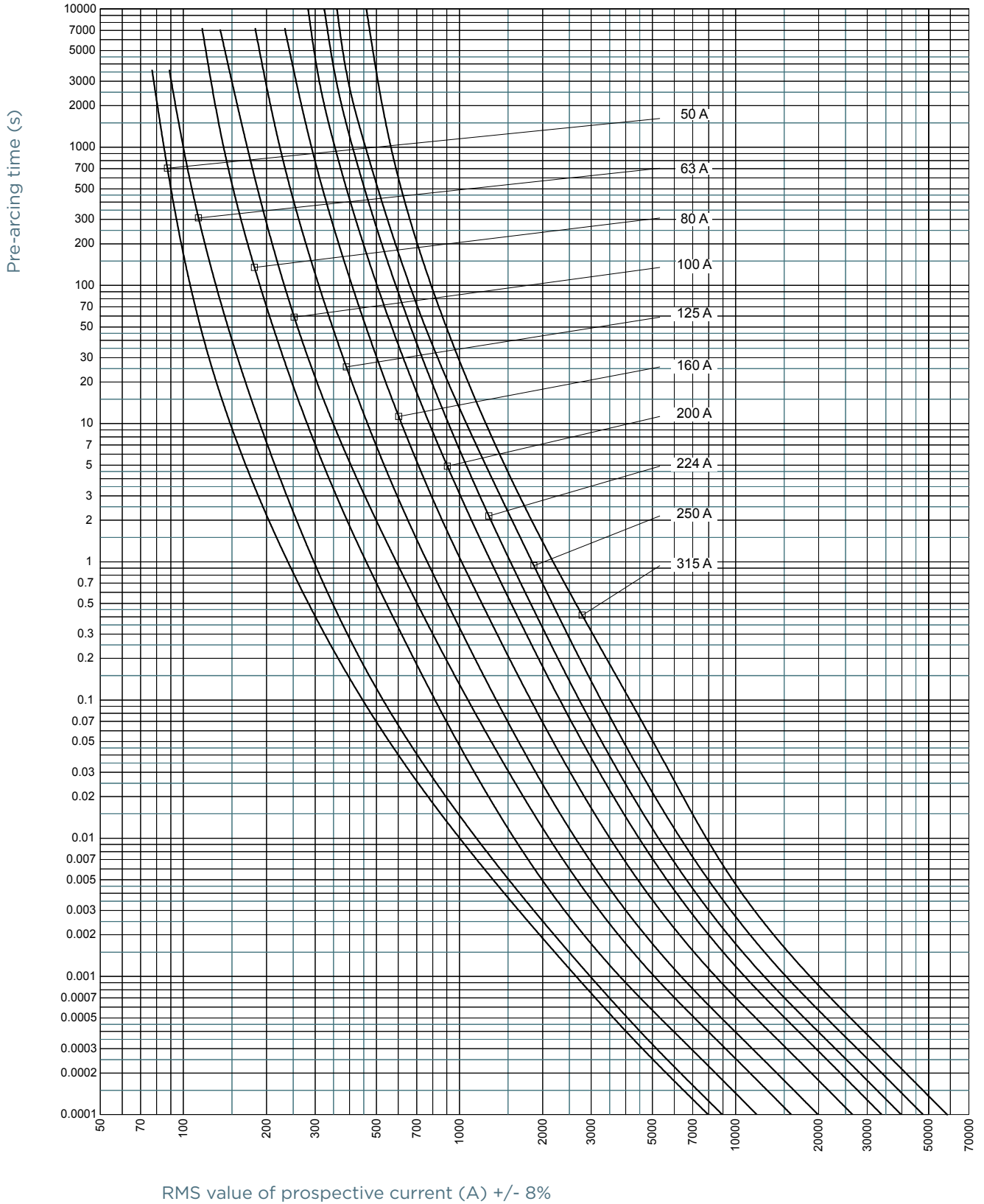

MERSEN reserves the right to change, update or correct, without notice, any information contained in this datasheet.

NH fuse-links gG 500VAC

double indicator/isolated gripping-lugs size 000, 00, 0, 1, 2, 3

TIME CURRENT CHARACTERISTIC CURVES

Size 2

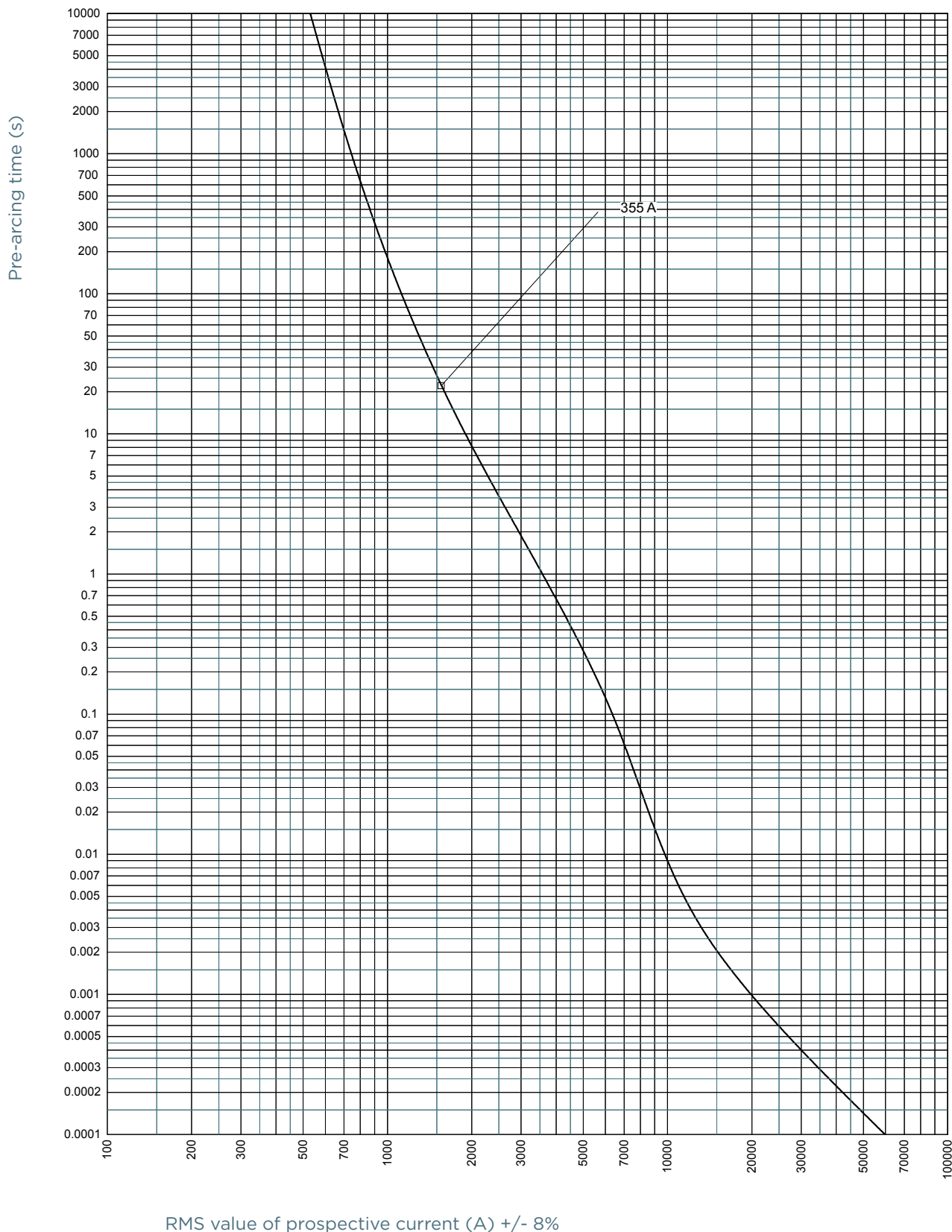

MERSEN reserves the right to change, update or correct, without notice, any information contained in this datasheet.

NH fuse-links gG 500VAC

double indicator/isolated gripping-lugs size 000, 00, 0, 1, 2, 3

TIME CURRENT CHARACTERISTIC CURVES

Size 3

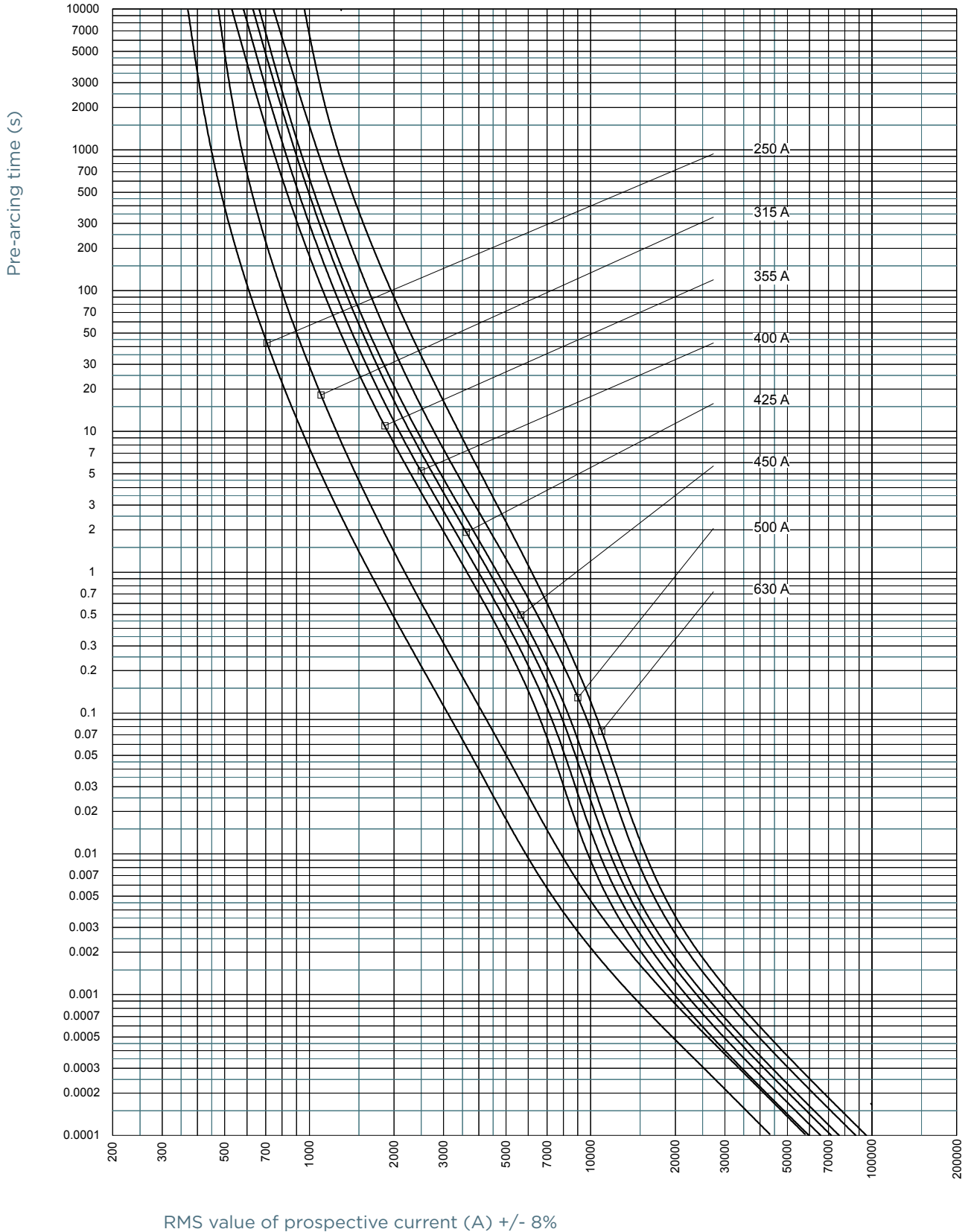

MERSEN reserves the right to change, update or correct, without notice, any information contained in this datasheet.

NH fuse-links gG 500VAC

double indicator/isolated gripping-lugs size 000, 00, 0, 1, 2, 3

CUT-OFF CURRENT CHARACTERISTIC

Size 000

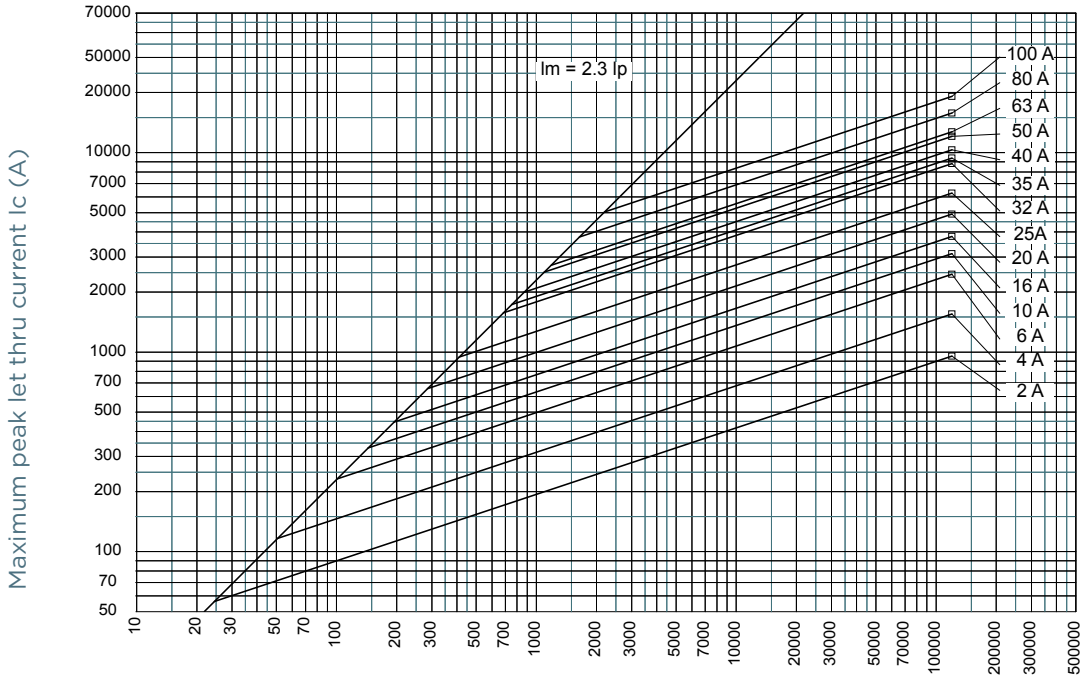

50 Hz RMS symmetrical prospective current I_p (A)

Size 00

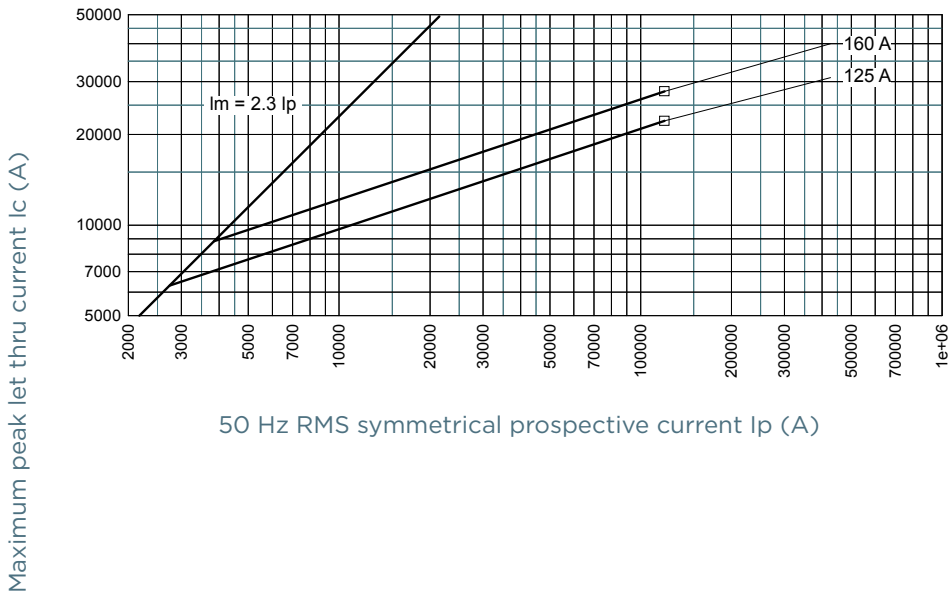

50 Hz RMS symmetrical prospective current I_p (A)

MERSEN reserves the right to change, update or correct, without notice, any information contained in this datasheet.

NH fuse-links gG 500VAC

double indicator/isolated gripping-lugs size 000, 00, 0, 1, 2, 3

CUT-OFF CURRENT CHARACTERISTIC

Size 0

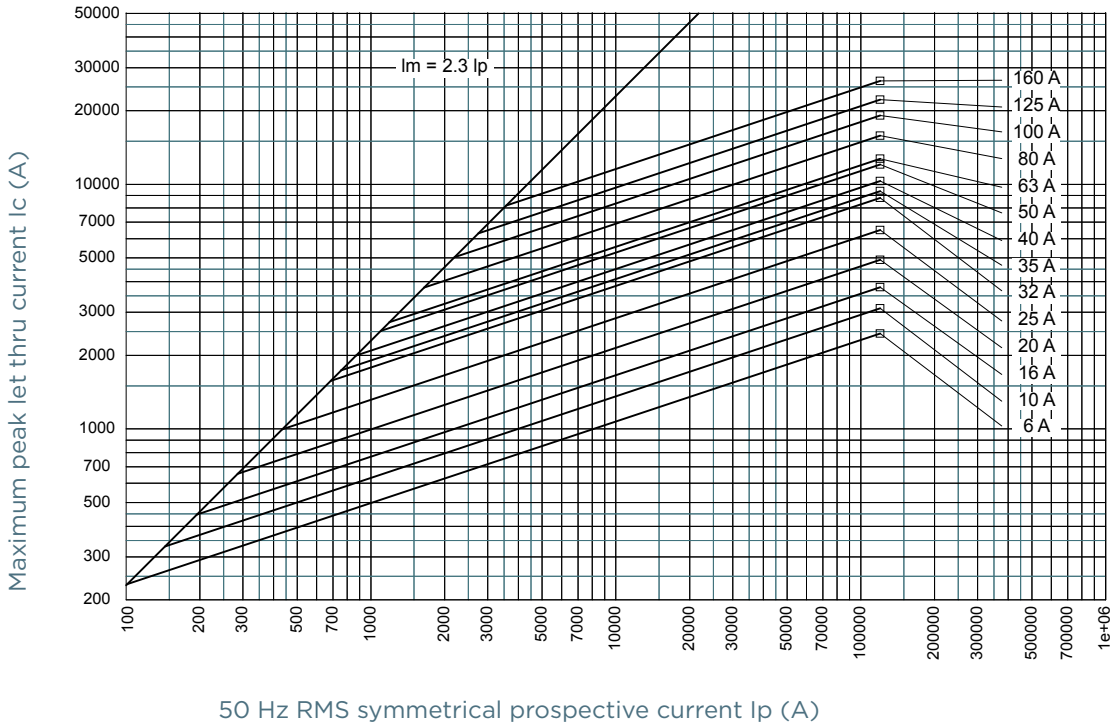

Size 1

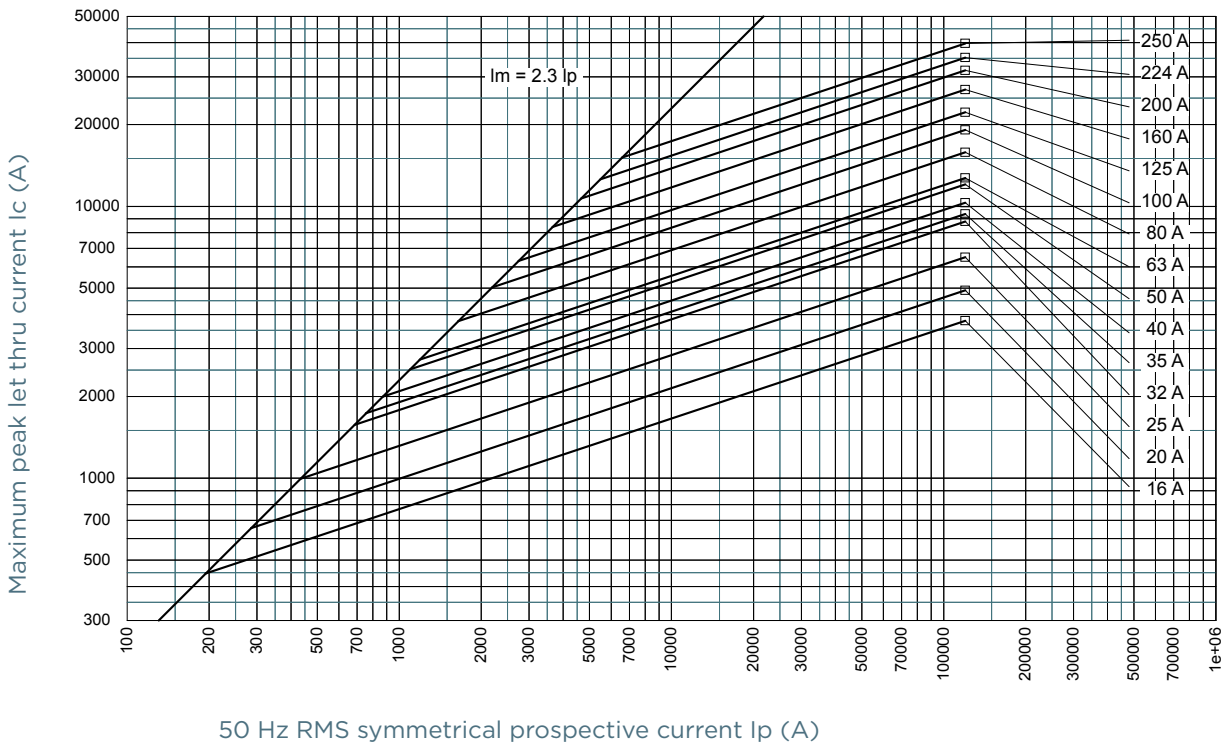

NH fuse-links gG 500VAC

double indicator/isolated gripping-lugs size 000, 00, 0, 1, 2, 3

CUT-OFF CURRENT CHARACTERISTIC

Size 2

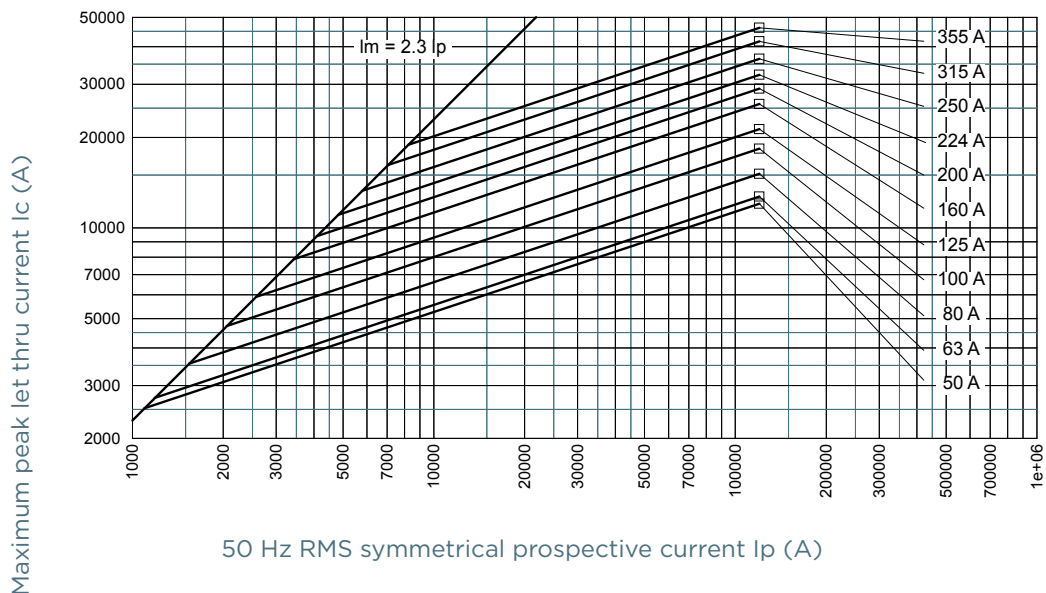

Size 3

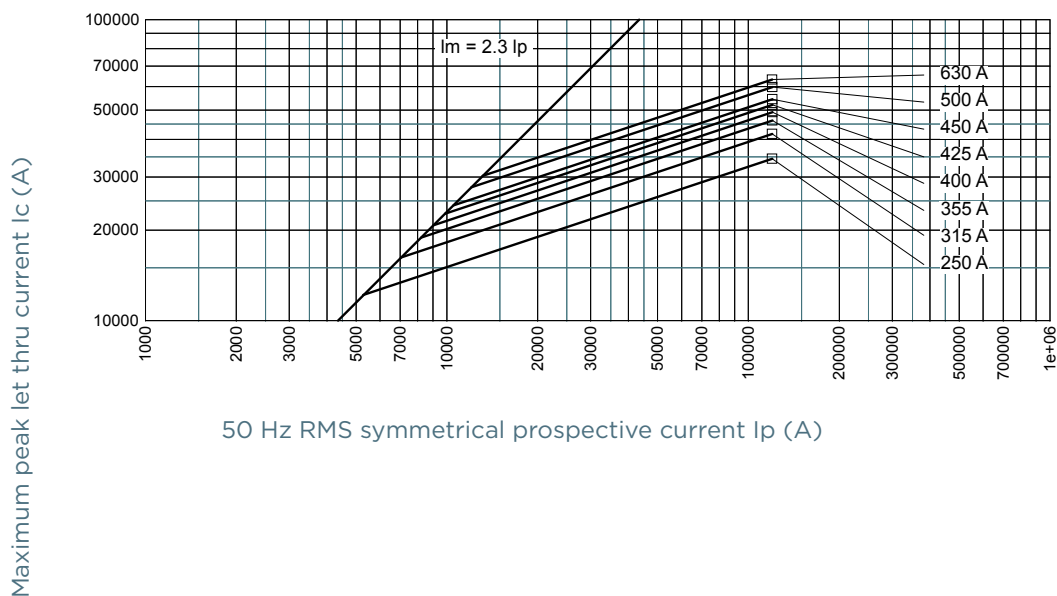

NH fuse-links gG 500VAC

double indicator/isolated gripping-lugs size 000, 00, 0, 1, 2, 3

PRE-ARCING AND OPERATING I²t CHARACTERISTICS

Size 000

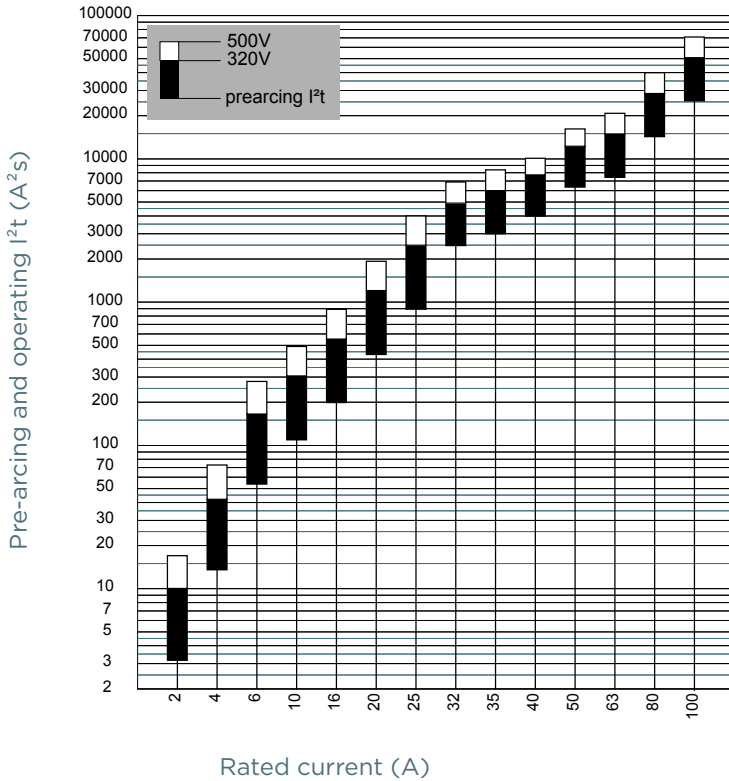

Size 00

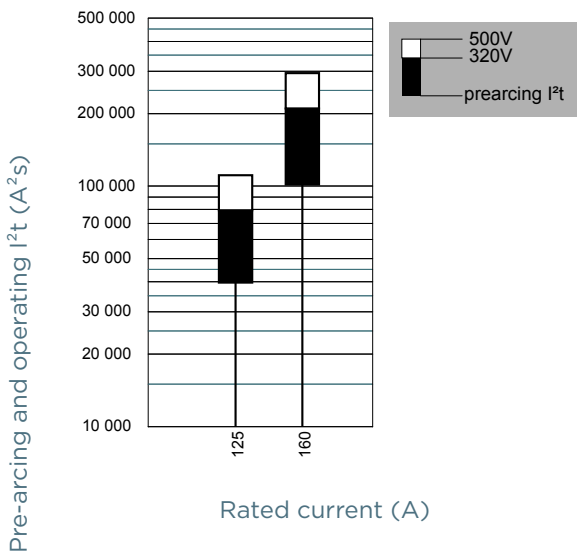

MERSEN reserves the right to change, update or correct, without notice, any information contained in this datasheet.

NH fuse-links gG 500VAC

double indicator/isolated gripping-lugs size 000, 00, 0, 1, 2, 3

PRE-ARCING AND OPERATING I²t CHARACTERISTICS

Size 0

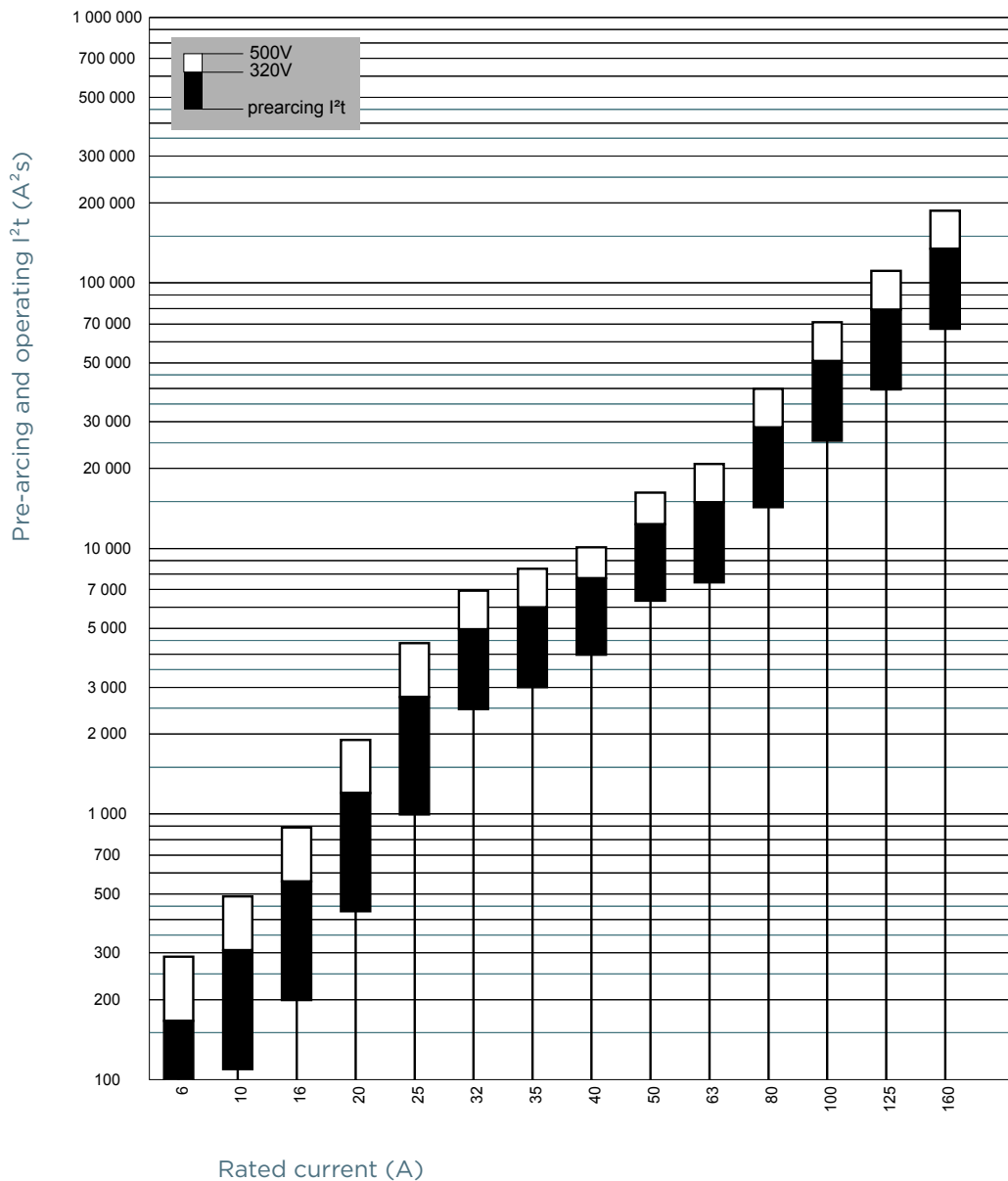

NH fuse-links gG 500VAC

double indicator/isolated gripping-lugs size 000, 00, 0, 1, 2, 3

PRE-ARCING AND OPERATING I²t CHARACTERISTICS

Size 1

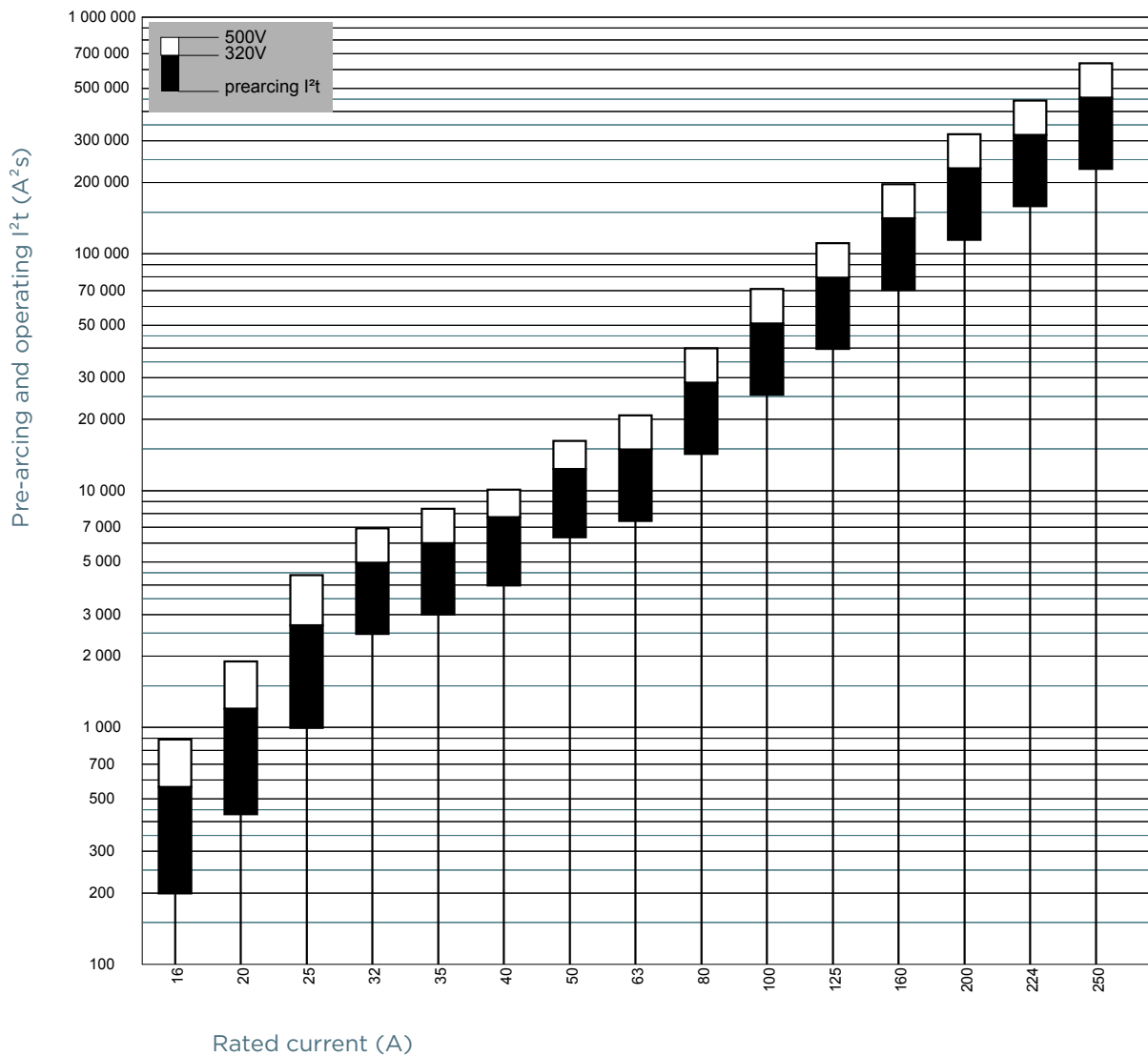

MERSEN reserves the right to change, update or correct, without notice, any information contained in this datasheet.

NH fuse-links gG 500VAC

double indicator/isolated gripping-lugs size 000, 00, 0, 1, 2, 3

PRE-ARCING AND OPERATING I²T CHARACTERISTICS

Size 2

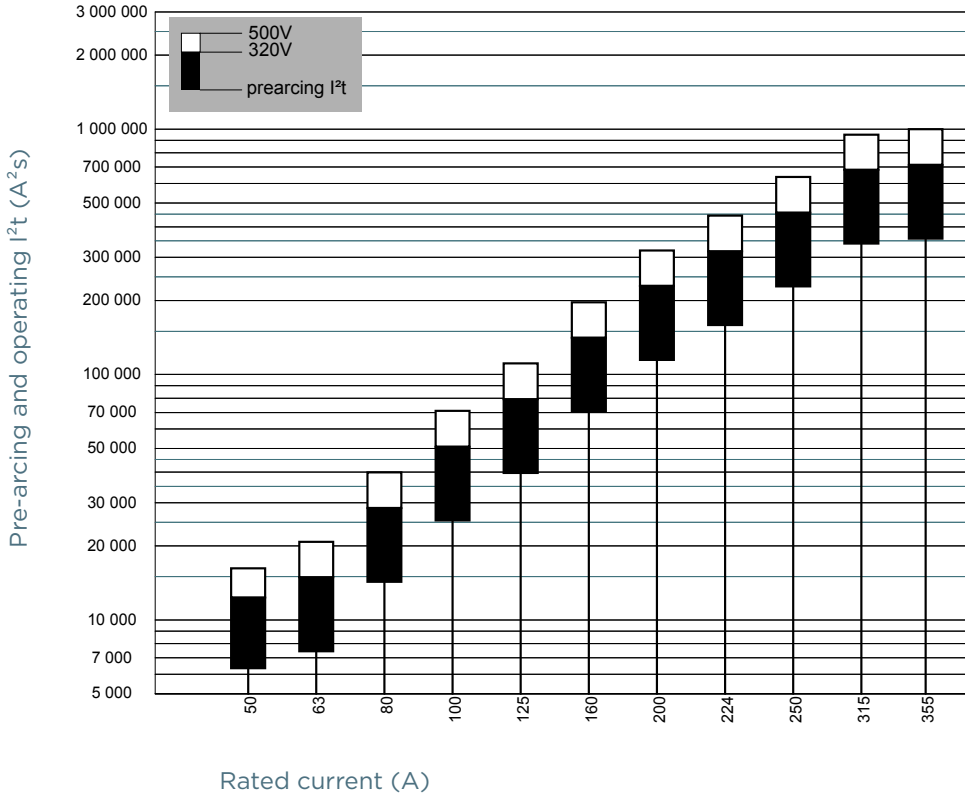

Size 3

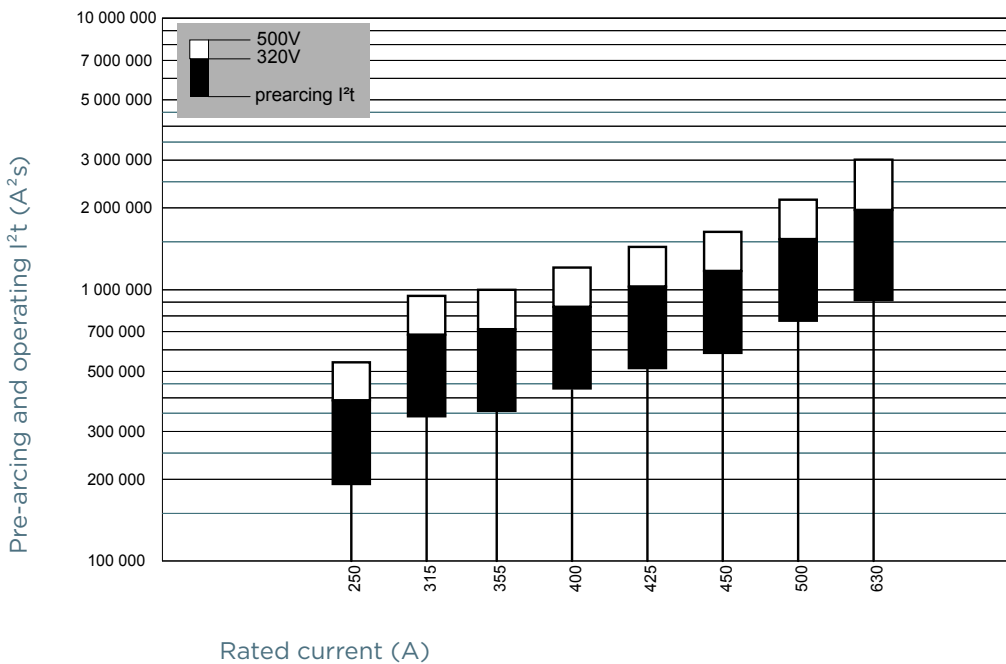

MERSEN reserves the right to change, update or correct, without notice, any information contained in this datasheet.

NH fuse-links gG 500VAC

double indicator/isolated gripping-lugs size 000, 00, 0, 1, 2, 3

DIMENSIONS

Size 000 with double indicator (1000405A)

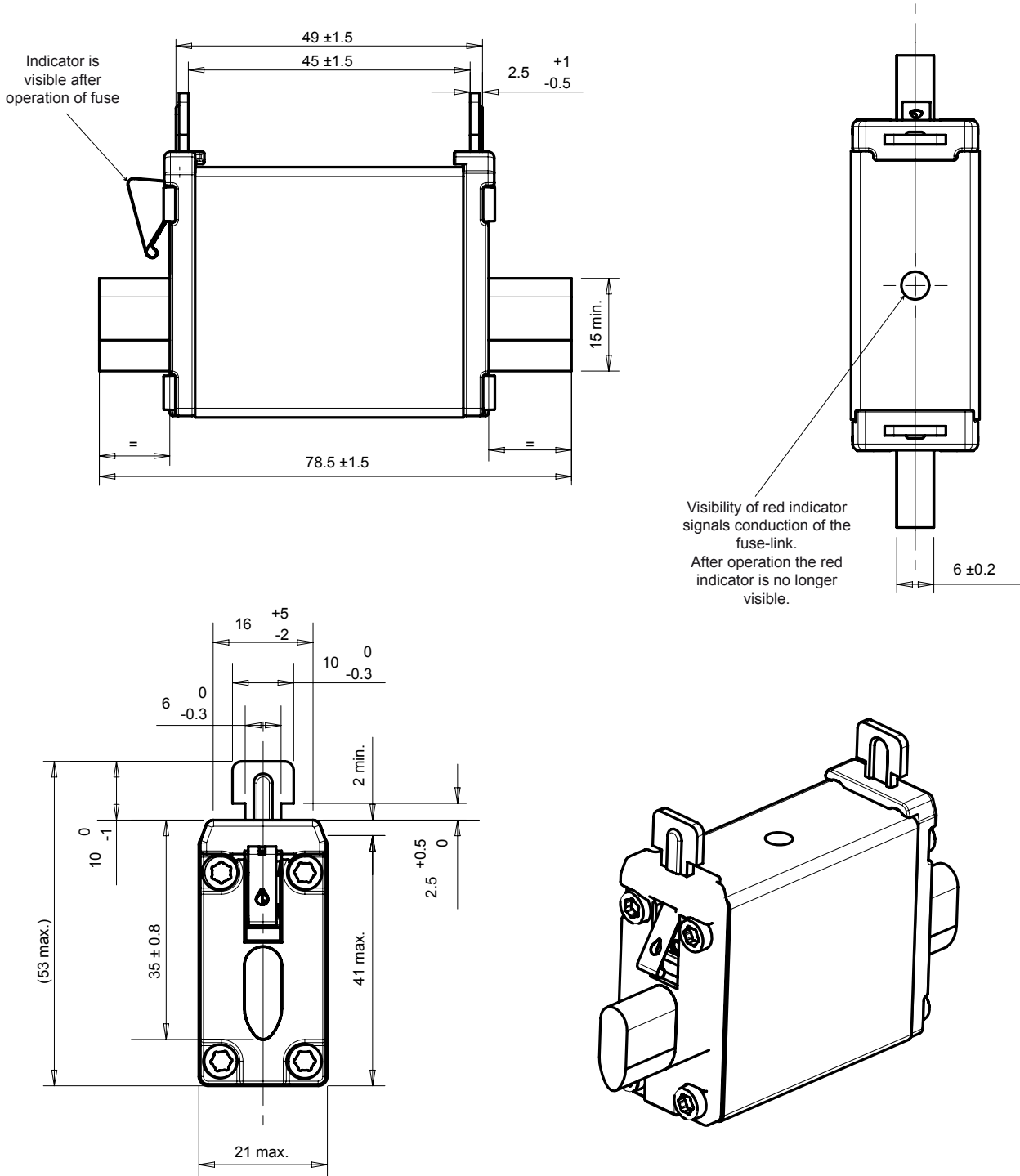

Dimensions in mm

NH fuse-links gG 500VAC

double indicator/isolated gripping-lugs size 000, 00, 0, 1, 2, 3

DIMENSIONS

Size 00 with double indicator (1000406A)

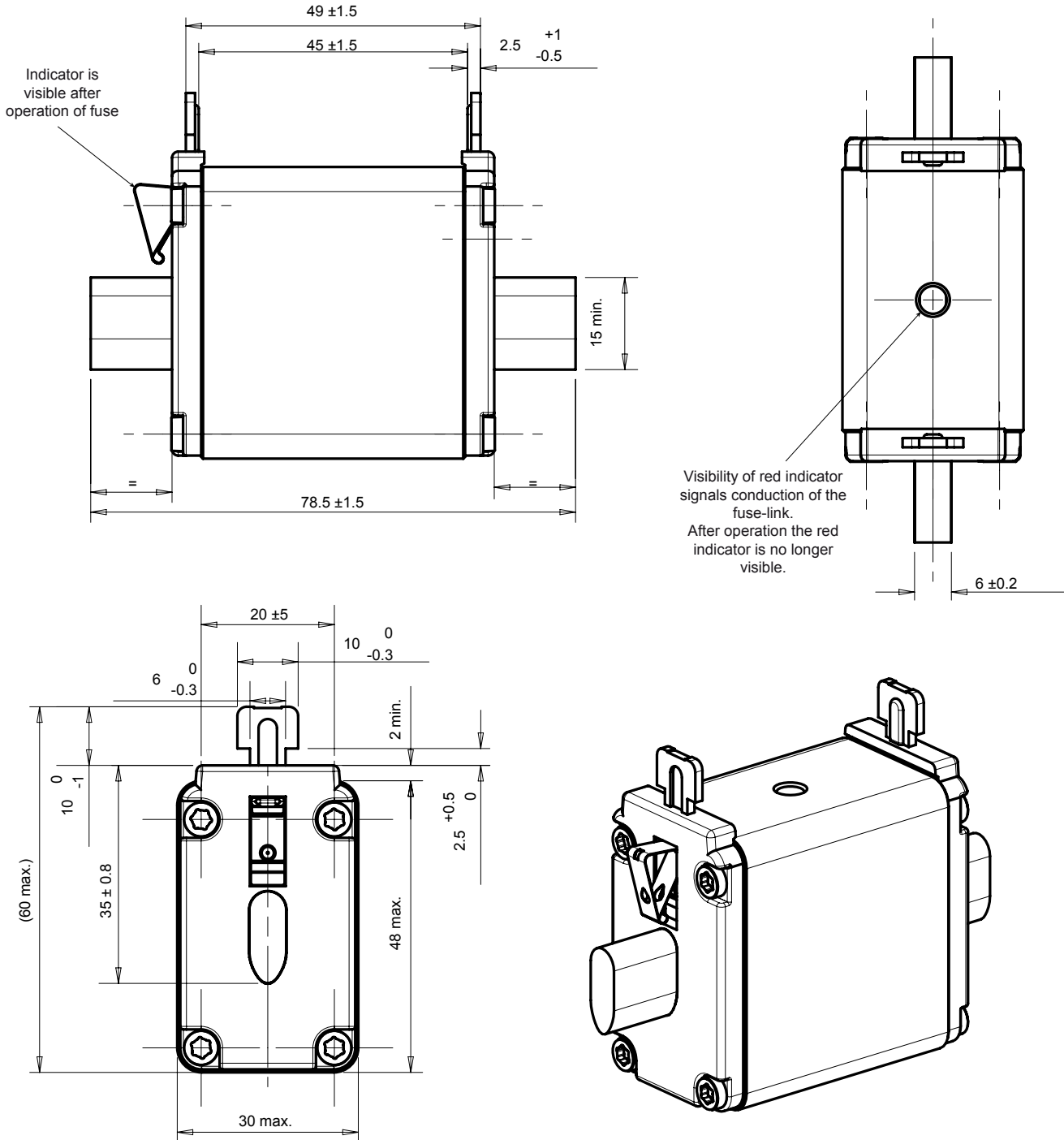

Dimensions in mm

NH fuse-links gG 500VAC

double indicator/isolated gripping-lugs size 000, 00, 0, 1, 2, 3

DIMENSIONS

Size 0 with double indicator (1000407A)

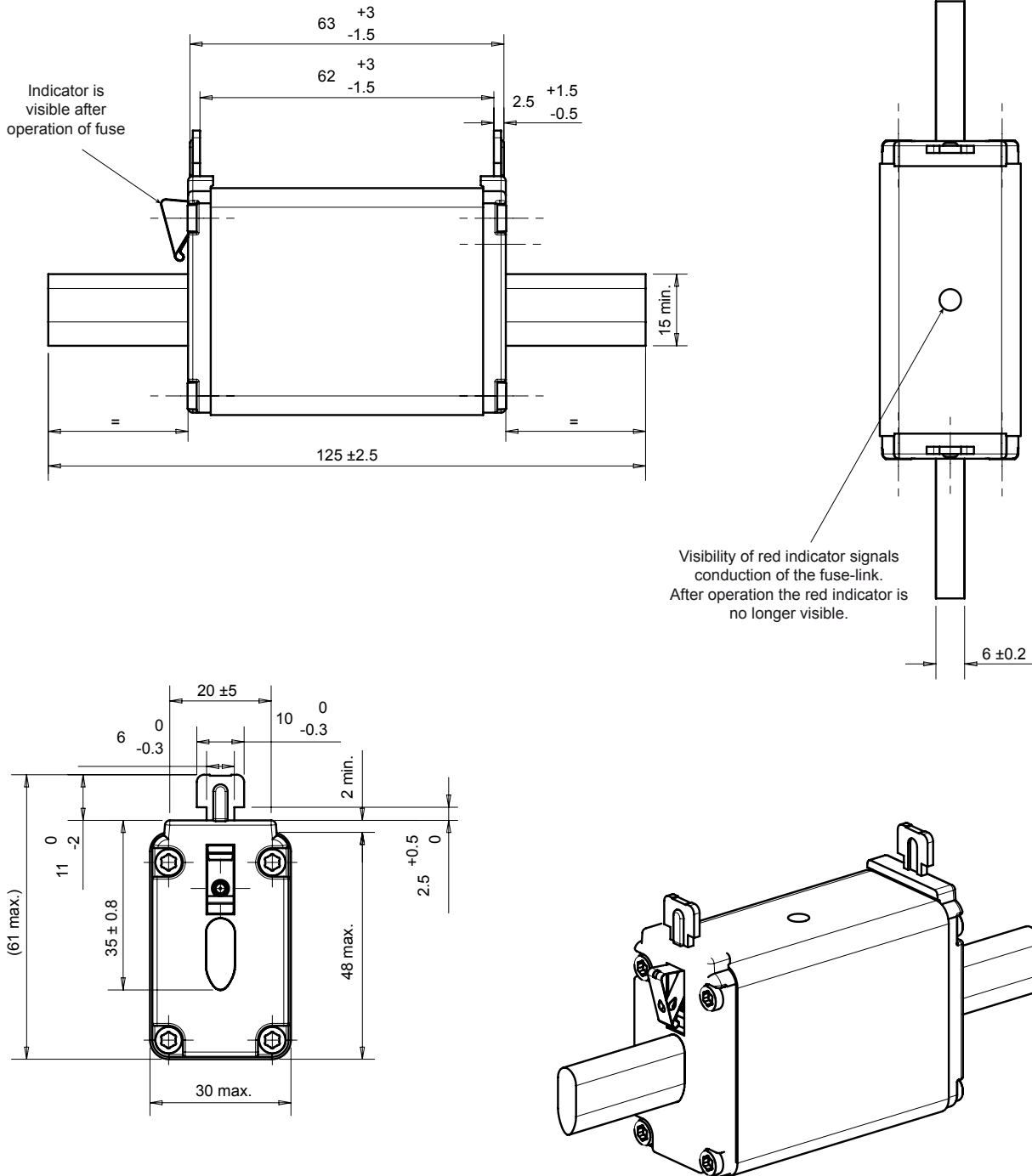

Dimensions in mm

NH fuse-links gG 500VAC

double indicator/isolated gripping-lugs size 000, 00, 0, 1, 2, 3

DIMENSIONS

Size 1 compact with double indicator (16-125A) (1000586A)

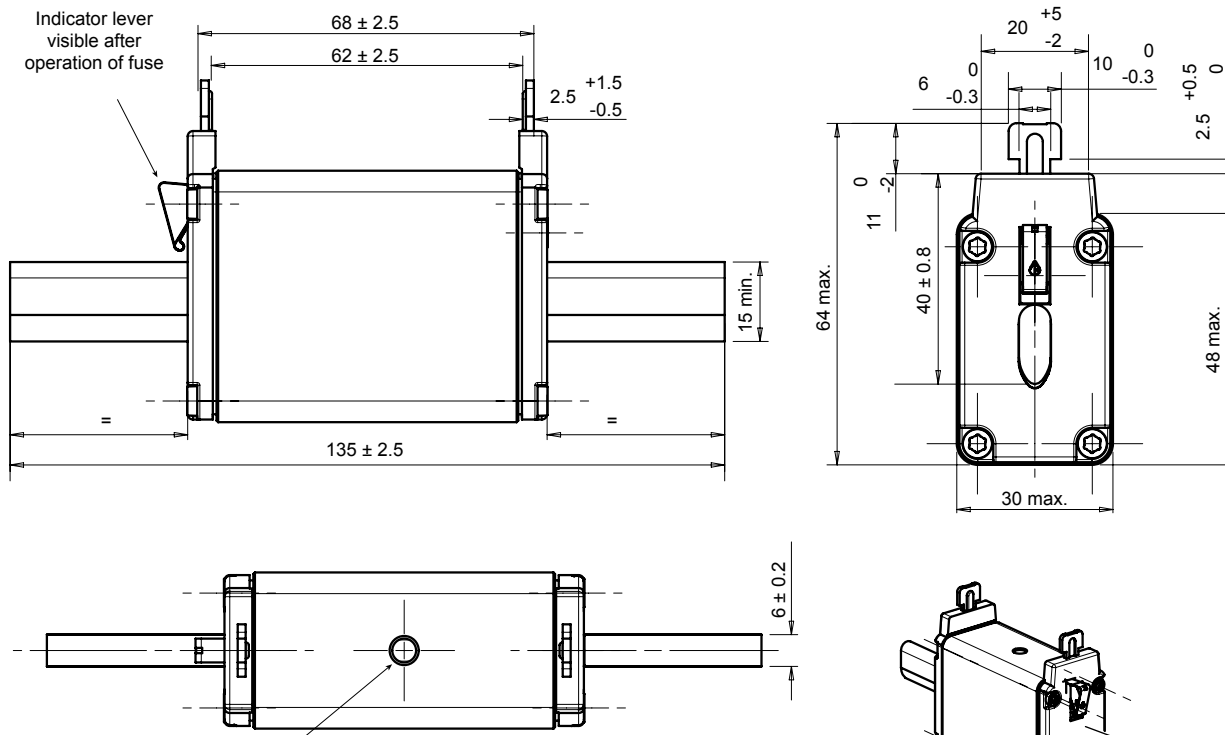

Visibility of red indicator signals conduction of the fuse-link.
After operation the red indicator is no longer visible

Dimensions in mm

NH fuse-links gG 500VAC

double indicator/isolated gripping-lugs size 000, 00, 0, 1, 2, 3

DIMENSIONS

Size 1 with double indicator (160-250A) (1000408A)

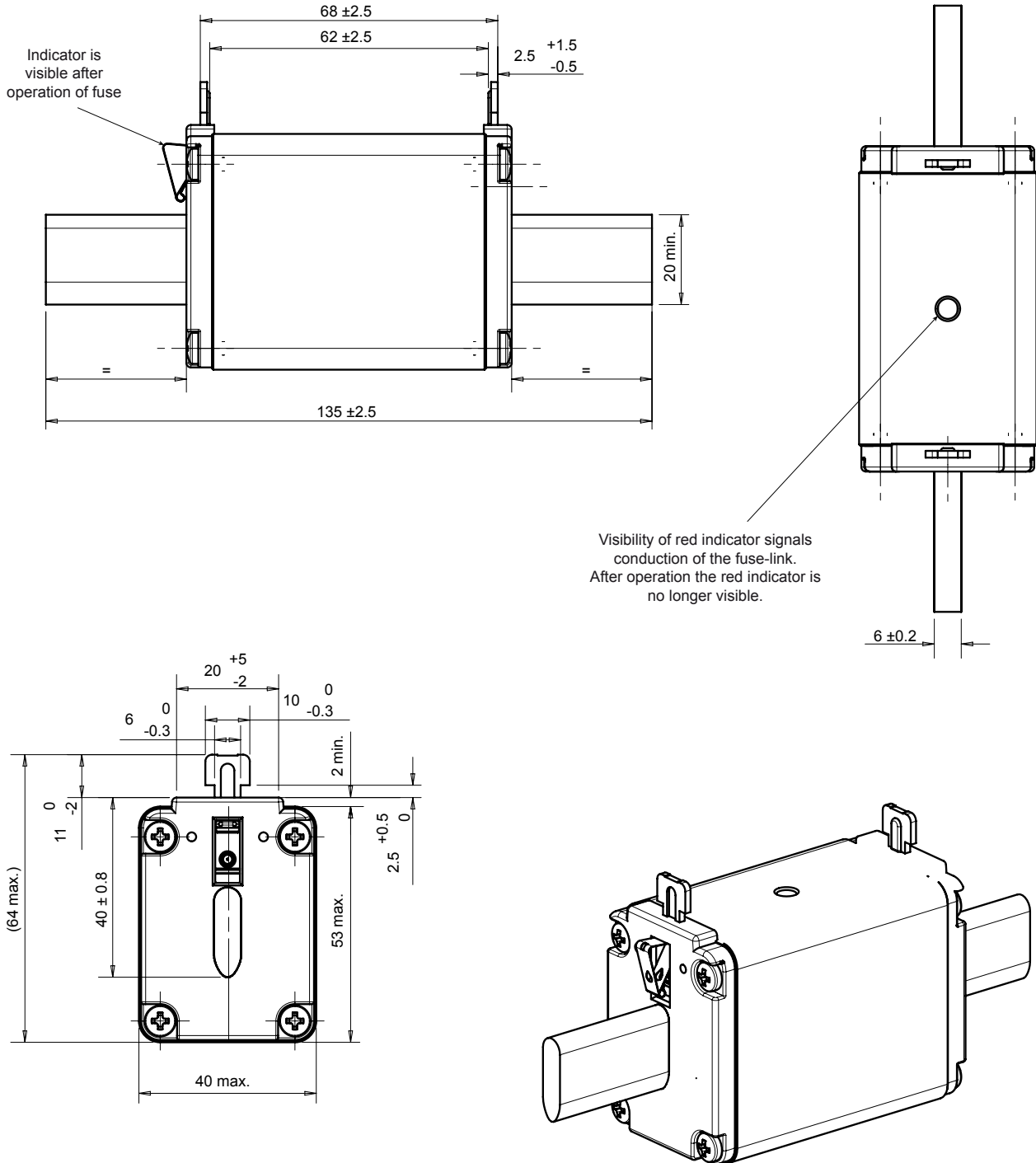

Dimensions in mm

NH fuse-links gG 500VAC

double indicator/isolated gripping-lugs size 000, 00, 0, 1, 2, 3

DIMENSIONS

Size 2 compact with double indicator (25-250A) (1000584B)

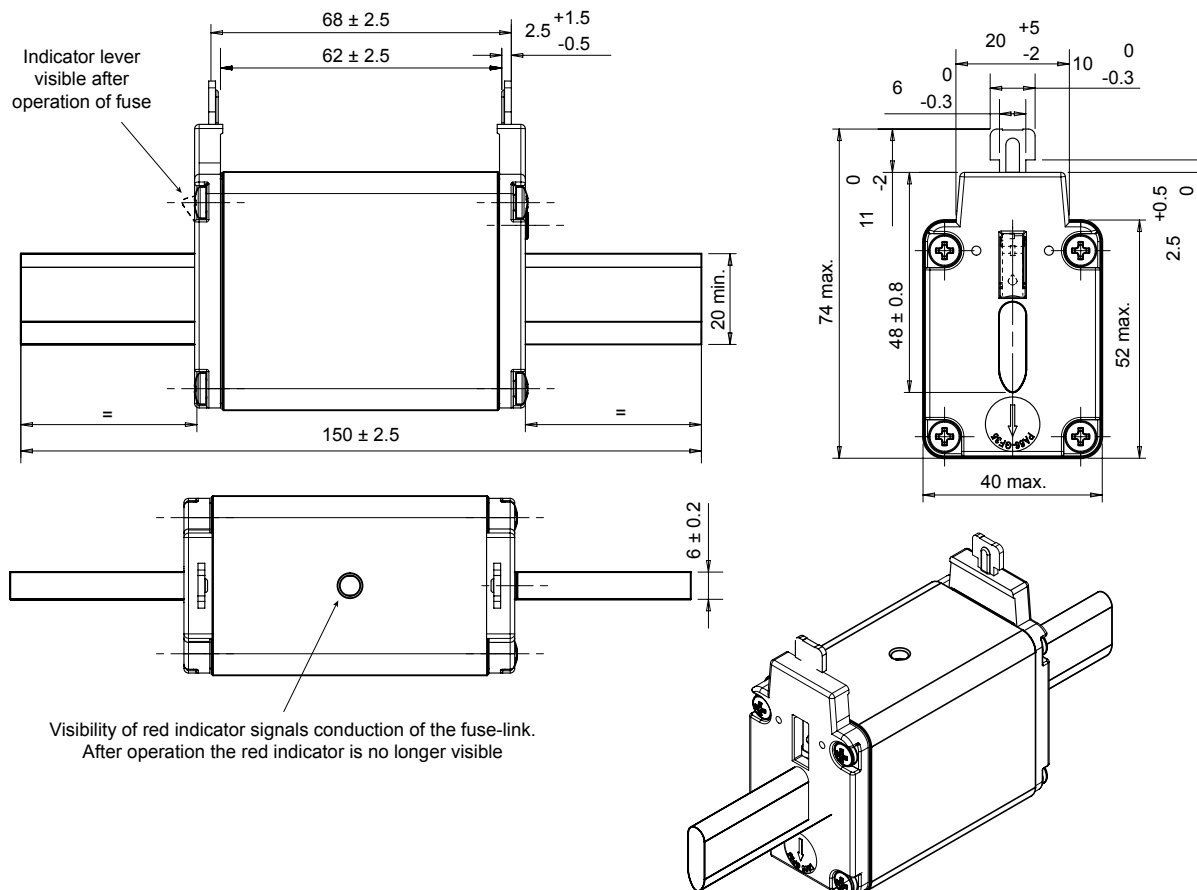

Dimensions in mm

NH fuse-links gG 500VAC

double indicator/isolated gripping-lugs size 000, 00, 0, 1, 2, 3

DIMENSIONS

Size 2 with double indicator (300-400A) (1000409A)

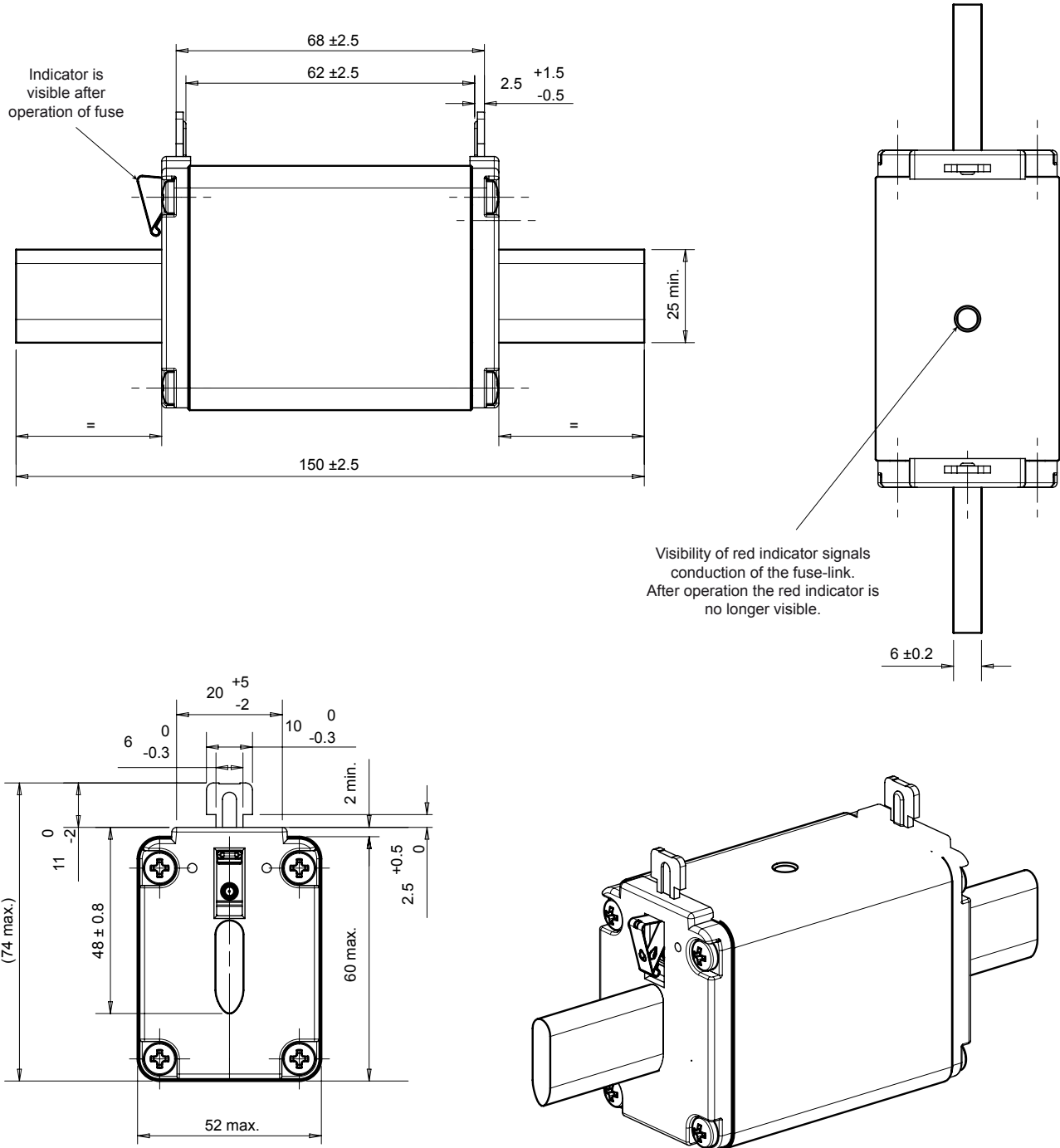

Dimensions in mm

NH fuse-links gG 500VAC

double indicator/isolated gripping-lugs size 000, 00, 0, 1, 2, 3

DIMENSIONS

Size 3 compact with double indicator (250-400A) (1000583A)

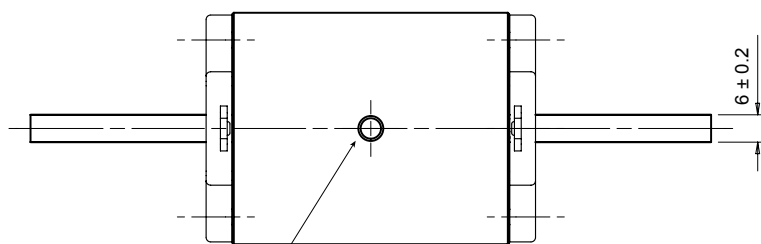
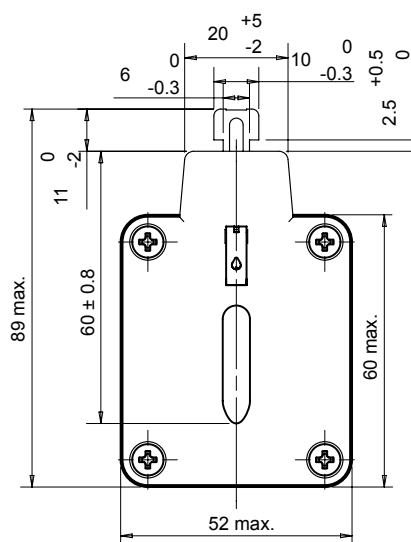
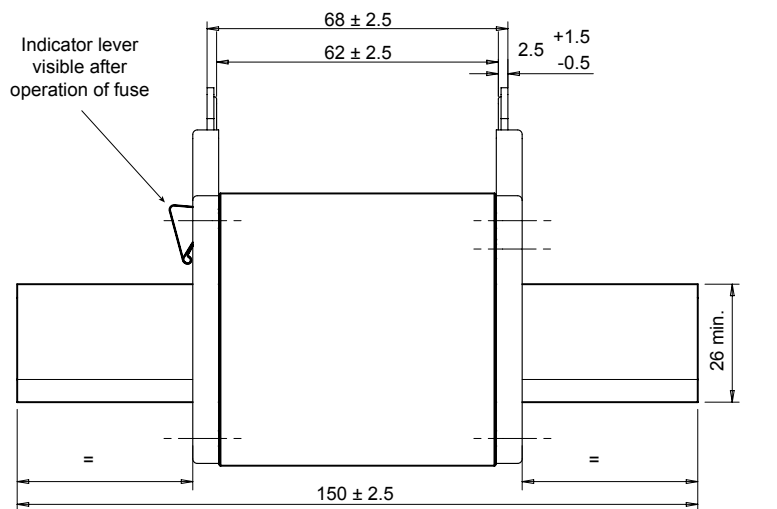

Visibility of red indicator signals conduction of the fuse-link.
After operation the red indicator is no longer visible

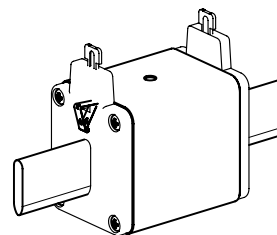

Dimensions in mm

NH fuse-links gG 500VAC

double indicator/isolated gripping-lugs size 000, 00, 0, 1, 2, 3

DIMENSIONS

Size 3 with double indicator (425-630A) (10004010A)

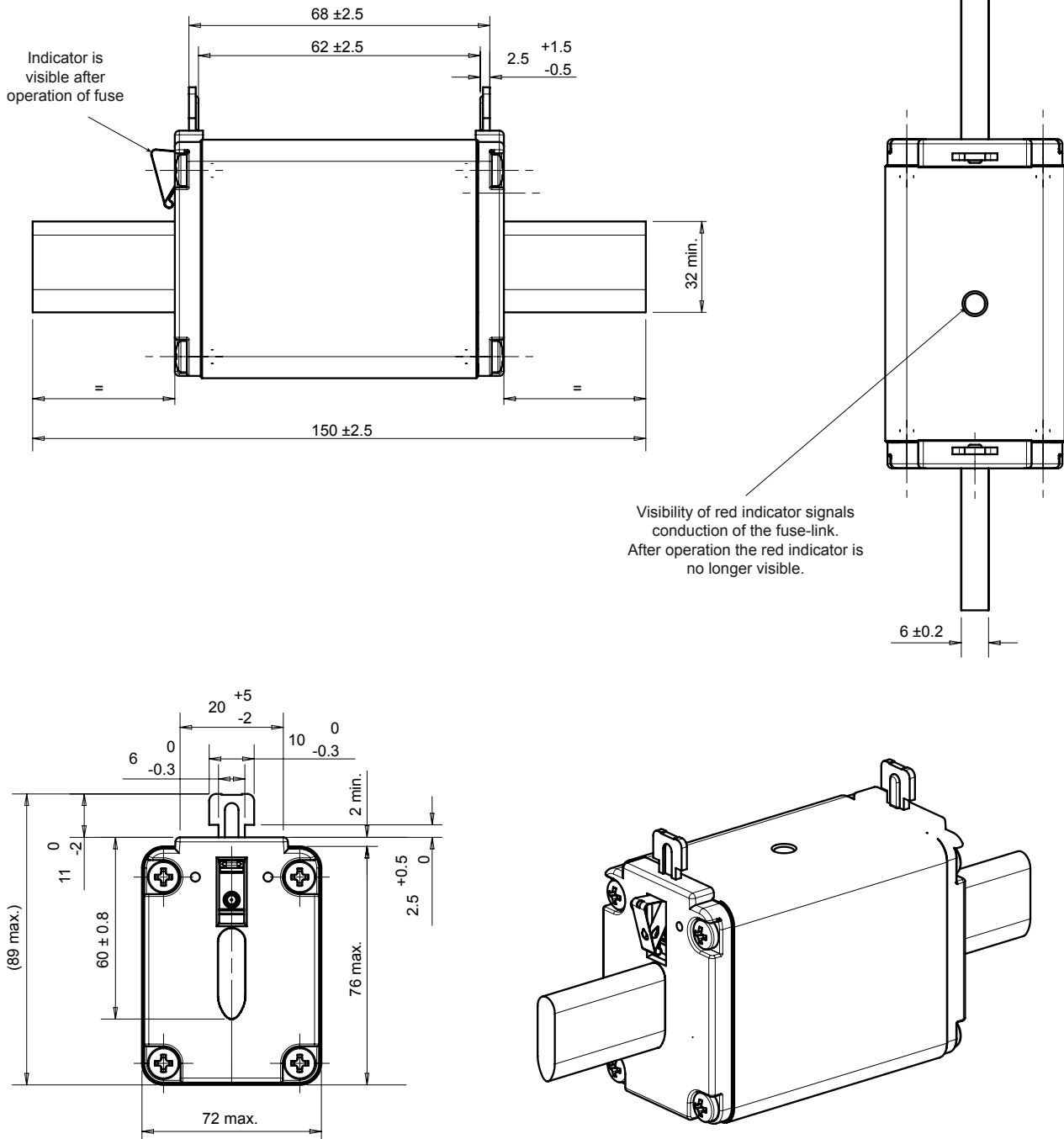

Dimensions in mm