



SWL Series

Manual 767W to 4266W / 10 min

Valve Regulated Lead Acid Batteries



Contents

- SWL Battery range2
- Specifications3
- Layout3
- Terminals3
- Performance tables4-5-6
- Charging7
- Discharge8
- Self discharge9
- Open circuit voltage and remaining capacity9
- Service life in floating10
- Temperature10
- Standards11
- Transport11
- Environment11
- Rules of use11
- Service11
- Installation12

SWL

Battery range

Yuasa proposes a full range of stationary VRLA batteries with gas recombination, regulated with valves.

With a typical power of 767W to 4266 W per monobloc (discharge 10 min), Yuasa succeeded with this range to optimise strongly the voluminal power.

More energy

30 to 40% more energy for autonomy of 10 minutes in relation to a standard battery of the same weight, same dimensions and same service life (Fig. 1).

Thanks to a unique optimisation process on the active materials of the plates, which favours electrochemical exchange, the fast discharge performances have been increased whilst retaining an optimal service life.

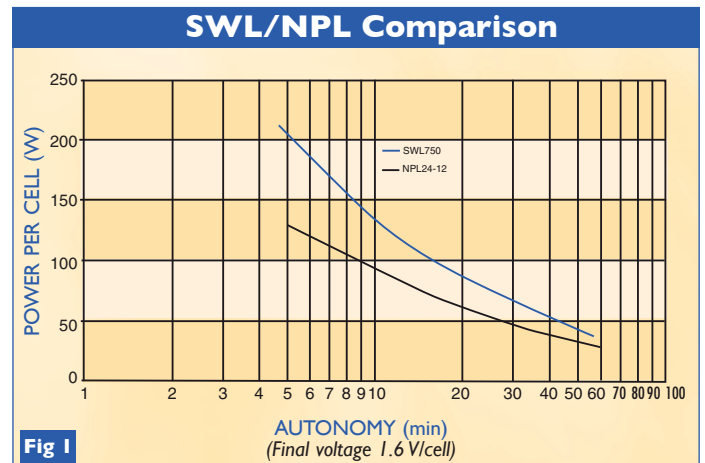

General characteristics

- VRLA
- Electrolyte immobilisation system (AGM)
- Operates in any positions (except upside down)
- Gas recombination at more than 99%
- Low pressure safety relief valves
- No maintenance
- Container in ABS UL94 HB (standard) or V0 (flame retardant)
- Series and parallel assembly
- Lead-tin-calcium plates with high output
- Long service life
- Low auto-discharge / Long storage life
- Wide operating temperature range
- Use in floating operation.
- Excellent performance with fast discharge
- Good recovery after deep discharge



Specifications

	Type of Battery	Nominal Voltage (V)	Typical Power 10min* (W)	Capacity		Length (mm)	Width (mm)	Height (mm)	Weight (Kg)	Layout (bilow)	Terminals (bilow)	maximum Current in 1 mn (A)	maximum Current in 1 sec. (A)	Internal Impedance (mΩ)***
				10h** (Ah)	20h** (Ah)									
FR	SWL750	12	767	22.9	24.4	166	175	125	9.3	2	A	150	500	9.5
FR	SWL780V	12	815	27.1	28.4	166	125	175	10,1	2	A	150	500	8.5
FR	SWL1100	12	1202	39.6	40	197	165	170	14.5	2	B	200	500	7.5
FR	SWL1800	12	1974	55	56.6	216	168	223	23	I	B	500	800	6.0
FR	SWL1850	12	1916	66	72	350	166	174	23.8	2	C	500	800	5
FR	SWL2250	12	2250	76	84	380	166	185	28.4	2	C	500	800	2.5
FR	SWL2300	12	2400	78	79	259	168	212.5	27	I	B	240	520	5.5
FR	SWL2300E	12	2400	78	79	260	168	225	28	I	B	400	800	5.5
FR	SWL2500T	12	2940	91.4	92.4	305	173	223	32	I	C	500	1000	6.5
FR	SWL2500E	12	2940	91.4	92.4	305	168	225	33	I	B	500	1000	5.0
FR	SWL3300	12	3300	102.5	108.4	350	168	225	38	I	C	550	1100	3.5
FR	SWL3800	12	3900	124	134	350	173	272	48	I	C	600	1200	3
FR	SWL4250	12	4266	140	148	341	173	281	49	I	C	420	840	2.7
FR	SWL1850-6	6	1344	132	144	350	166	174	23.5	3	C	260	500	1.6
FR	SWL2500-6	6	2766	180	182	297	168	231,5	32.5	3	C	800	1500	3

- * : Final voltage at 1.6V/cell – Temperature 20°C.
- ** : C₁₀ or C₂₀ / Final voltage at 1.8V/cell – Temperature 20°C
- ***: Battery charged and measured at 1000 Hz.

FR : Optional UL94-V0 container.

The capacity at C100 (100h) = Capacity at C20 (20h) × 1,1.
Ex : the capacity at 100h for SWL 2500 is 101 Ah .

Layout

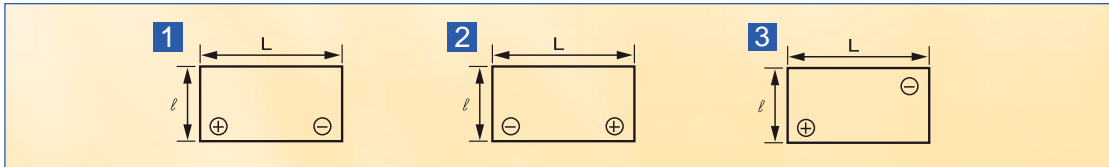

Terminals

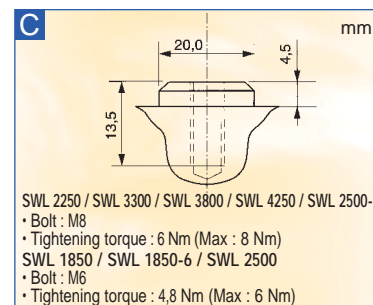
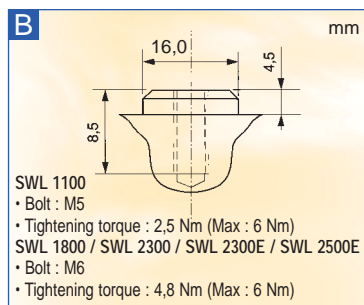
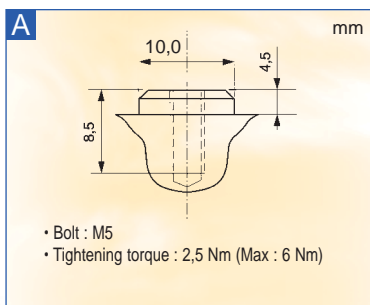

Performance tables for constant power discharge

Discharge power (Watt) per cell for final voltage of 1.6V at 20°C

Type of Battery	AUTONOMY										Hours									
	Minutes										Hours									
	3	5	6	10	15	20	30	40	50	60	1.5	2	2.5	3	4	5	6	10	15	20
SWL750	239	196	179	128	105	87.5	66.3	51.5	42.4	38.0	28.3	23.1	18.6	15.7	11.8	9.68	8.08	5.83	4.01	3.06
SWL780V	250	205	187	136	106	88.6	63.1	52.8	44.8	39.1	28.2	22.1	18.4	15.6	12.2	10.0	8.55	5.50	3.80	2.89
SWL1100	346	285	263	200	160	129	94.0	77.8	67.0	58.7	42.7	33.7	28.0	24.2	18.8	15.8	13.7	9.67	6.64	5.08
SWL1800	553	476	440	329	257	213	160	128	108	92.8	65.3	51.8	44.0	38.5	30.9	25.3	21.3	13.1	9.12	7.05
SWL1850	536	453	420	319	254	210	153	125	109	96.3	70.0	54.2	45.2	39.7	31.7	27.0	23.3	16.3	11.2	8.56
SWL2250	582	524	492	375	307	251	182	149	128	112	82.7	65.9	54.9	48.2	38.5	32.8	28.4	19.9	13.6	10.4
SWL2300/E	573	571	525	400	303	253	194	156	129	111	80.3	63.3	52.8	45.5	35.9	29.7	25.2	16.0	10.7	8.01
SWL2500/E	751	649	583	490	373	303	236	188	158	135	95.3	74.2	61.7	53.7	42.3	35.3	30.3	19.3	13.2	10.0
SWL3300	769	767	697	550	433	359	273	220	183	158	115	89.6	74.5	64.6	51.0	42.3	35.9	22.0	15.2	11.8
SWL3800	863	861	817	650	508	414	308	246	204	176	130	103	85.0	73.0	57.2	47.1	39.8	24.9	17.4	13.4
SWL4250	961	959	899	711	585	484	366	293	246	212	149	119	99.5	86.0	67.9	56.5	47.9	29.9	20.6	15.8
SWL1850-6	494	481	474	448	416	384	273	229	201	177	135	107	89.5	78.6	62.8	53.5	46.1	32.3	22.2	17.0
SWL2500-6	1160	1158	1133	922	696	573	432	351	299	261	185	147	123	106	80.2	65.3	55.8	36.3	24.2	18.1

Discharge power (Watt) per cell for final voltage of 1.65V at 20°C

Type of Battery	AUTONOMY										Hours									
	Minutes										Hours									
	3	5	6	10	15	20	30	40	50	60	1.5	2	2.5	3	4	5	6	10	15	20
SWL750	229	191	176	127	105	87.3	66.2	51.2	42.2	37.8	28.2	23.0	18.5	15.6	11.7	9.53	7.92	5.67	3.89	2.98
SWL780V	238	199	181	133	104	88.2	62.9	52.7	44.6	39.0	28.1	22.0	18.3	15.6	12.1	10.0	8.51	5.46	3.76	2.88
SWL1100	331	276	256	196	158	128	93.5	77.3	66.7	58.2	42.2	33.3	27.7	24.0	18.5	15.5	13.5	9.33	6.41	4.90
SWL1800	530	458	424	322	256	211	158	127	107	92.3	64.8	51.5	43.8	38.3	30.7	25.2	21.2	13.0	9.05	6.98
SWL1850	511	437	411	318	252	209	153	125	109	95.5	69.7	53.7	44.7	39.3	31.3	26.7	23.0	16.0	11.0	8.40
SWL2250	578	517	483	370	305	249	180	148	127	111	82.3	65.3	54.3	47.8	38.1	32.4	28.0	19.5	13.4	10.2
SWL2300/E	546	544	511	386	297	249	193	155	129	111	80.0	63.0	52.7	45.4	35.7	29.5	25.1	16.0	10.7	7.99
SWL2500/E	733	605	562	477	370	302	233	186	155	132	92.9	73.4	61.5	53.4	42.2	35.2	30.2	19.3	13.2	10.0
SWL3300	715	714	657	533	423	353	271	219	182	157	114	89.2	74.3	64.3	50.8	42.2	35.8	22.0	15.2	11.8
SWL3800	821	819	770	632	499	409	306	243	202	174	129	103	84.8	72.8	57.0	46.7	39.5	24.6	17.2	13.4
SWL4250	918	916	859	690	572	479	364	291	245	212	149	119	99.4	85.9	67.8	56.3	47.7	29.7	20.5	15.8
SWL1850-6	494	481	474	448	416	384	272	228	200	175	134	106	88.5	77.8	62.0	52.9	45.5	31.7	21.8	16.6
SWL2500-6	1149	1147	1110	887	676	563	429	349	297	260	185	146	123	105	79.9	65.1	55.6	36.1	24.1	18.0

Discharge power (Watt) per cell for final voltage of 1.7V at 20°C

Type of Battery	AUTONOMY										Hours									
	3	5	6	10	15	20	30	40	50	60	1.5	2	2.5	3	4	5	6	10	15	20
SWL750	217	183	168	124	103	86.7	65.8	50.8	42.1	37.6	28.0	22.9	18.4	15.5	11.5	9.44	7.83	5.58	3.83	2.93
SWL780V	225	187	172	129	102	87.3	62.5	52.4	44.3	38.8	28.0	21.9	18.2	15.5	12.0	9.92	8.46	5.44	3.75	2.87
SWL1100	314	264	245	190	154	127	93.2	77.0	66.3	57.5	41.8	32.8	27.3	23.8	18.3	15.3	13.3	9.00	6.18	4.73
SWL1800	504	431	401	312	253	210	157	126	106	91.8	64.5	51.3	43.7	38.2	30.6	25.0	21.0	12.9	9.00	6.93
SWL1850	489	437	405	313	247	209	153	124	108	94.7	69.3	53.3	44.3	39.0	31.0	26.3	22.7	15.7	10.8	8.24
SWL2250	565	497	463	359	300	248	177	146	126	110	81.9	64.9	53.9	47.4	37.7	32.0	27.6	19.1	13.1	10.0
SWL2300/E	522	520	491	366	287	243	191	154	127	110	79.6	62.7	52.4	45.2	35.6	29.4	24.9	15.9	10.6	7.95
SWL2500/E	680	568	545	453	363	299	223	180	150	131	92.7	73.3	61.3	53.2	42.2	35.0	30.2	19.3	13.2	10.0
SWL3300	667	666	622	509	412	346	267	216	180	155	113	88.6	73.8	64.1	50.5	42.0	35.6	21.8	15.1	11.7
SWL3800	770	768	727	607	483	401	302	241	200	173	128	102	84.4	72.5	56.7	46.5	39.3	24.5	17.1	13.3
SWL4250	872	870	811	662	551	467	359	288	243	210	148	118	99.1	85.6	67.5	56.0	47.4	29.5	20.4	15.7
SWL1850-6	492	479	472	447	415	383	272	227	199	174	133	106	87.7	77.2	61.4	52.1	44.9	31.1	21.3	16.3
SWL2500-6	1125	1123	1061	831	649	548	424	346	296	258	183	145	122	105	79.4	64.8	55.3	35.8	23.9	17.9

Discharge power (Watt) per cell for final voltage of 1.75V at 20°C

Type of Battery	AUTONOMY										Hours									
	3	5	6	10	15	20	30	40	50	60	1.5	2	2.5	3	4	5	6	10	15	20
SWL750	203	173	159	120	100	85.0	64.7	49.7	41.9	37.1	27.7	22.8	18.3	15.2	11.3	9.35	7.75	5.50	3.78	2.89
SWL780V	210	176	160	124	99.0	85.8	61.6	51.7	43.7	38.4	27.7	21.7	18.1	15.4	12.0	9.88	8.42	5.42	3.72	2.85
SWL1100	294	249	232	181	148	124	91.7	76.0	65.3	56.8	41.5	32.5	27.2	23.7	18.2	15.2	13.2	8.83	6.07	4.64
SWL1800	453	389	365	298	245	205	155	125	106	90.5	63.5	50.8	43.3	38.0	30.4	24.8	20.8	12.9	8.95	6.88
SWL1850	450	392	367	287	240	205	150	124	108	94.0	69.0	53.0	44.0	38.7	30.7	26.0	22.3	15.3	10.5	8.03
SWL2250	541	464	433	341	289	242	176	145	125	109	81.5	64.5	53.5	47.0	37.3	31.6	27.2	18.6	12.8	9.79
SWL2300/E	496	494	460	341	273	235	188	152	126	109	78.7	62.1	51.9	44.8	35.2	29.1	24.7	15.7	10.5	7.87
SWL2500/E	605	542	522	430	347	294	221	179	148	131	92.0	72.5	61.0	52.9	41.7	34.8	30.0	19.2	13.0	9.89
SWL3300	609	607	579	477	395	333	262	213	177	153	112	87.6	73.1	63.5	50.2	41.7	35.3	21.7	15.0	11.7
SWL3800	713	711	674	578	459	387	293	235	197	171	127	101	83.7	72.0	56.1	46.1	38.9	24.2	16.9	13.2
SWL4250	816	814	744	625	524	448	348	282	239	208	148	118	98.5	85.1	67.0	55.5	46.9	29.2	20.3	15.6
SWL1850-6	482	469	463	438	407	375	266	226	198	172	133	105	87.1	76.6	60.8	51.5	44.2	30.3	20.8	15.9
SWL2500-6	1058	1056	998	758	615	527	413	340	290	254	181	144	121	104	78.7	64.2	54.8	35.4	23.6	17.7

Discharge power (Watt) per cell for final voltage of 1.8V at 20°C

Type of Battery	AUTONOMY										Hours									
	Minutes																			
	3	5	6	10	15	20	30	40	50	60	1.5	2	2.5	3	4	5	6	10	15	20
SWL750	190	162	148	114	96.8	82.2	62.5	48.0	40.9	36.9	27.0	22.8	17.9	14.9	11.2	9.26	7.67	5.42	3.72	2.84
SWL780V	193	158	144	115	94.5	82.4	60.0	50.3	42.6	37.6	27.1	21.3	17.8	15.2	11.8	9.68	8.26	5.33	3.67	2.82
SWL1100	276	240	224	172	141	119	88.3	74.0	63.8	55.5	40.5	31.7	26.5	23.2	18.0	15.0	13.0	8.67	5.95	4.55
SWL1800	406	354	335	280	232	196	150	122	102	87.8	61.7	49.7	42.5	37.3	30.0	24.5	20.5	12.8	8.87	6.83
SWL1850	342	305	291	252	232	196	149	122	106	93.3	67.7	52.7	43.7	38.3	30.5	25.8	22.2	15.2	10.4	7.98
SWL2250	506	440	404	318	272	230	174	144	124	108	79.9	64.1	53.1	46.6	37.1	31.4	27.0	18.4	12.7	9.68
SWL2300/E	451	449	405	308	255	225	182	147	122	106	77.0	61.0	51.1	44.0	34.7	28.6	24.3	15.4	10.3	7.72
SWL2500/E	530	507	495	400	320	285	216	175	146	125	91.3	71.7	60.5	52.6	41.3	34.5	29.8	19.0	12.8	9.69
SWL3300	555	554	522	443	368	314	250	206	173	149	109	85.6	71.7	62.4	49.3	41.0	34.7	21.3	14.8	11.5
SWL3800	652	650	622	531	427	364	281	227	190	166	124	99.2	82.1	70.8	55.1	45.2	38.1	23.8	16.6	13.0
SWL4250	702	700	682	580	487	422	332	272	232	202	145	116	97.1	83.9	65.8	54.4	46.1	28.9	20.1	15.5
SWL1850-6	461	449	443	419	389	359	265	223	195	171	130	104	86.5	75.8	60.4	51.1	44.0	30.1	20.6	15.8
SWL2500-6	959	957	873	680	570	499	395	327	281	247	177	141	118	101	77.1	63.0	53.7	34.4	23.0	17.2

Discharge power (Watt) per cell for final voltage of 1.85V at 20°C

Type of Battery	AUTONOMY										Hours									
	Minutes																			
	3	5	6	10	15	20	30	40	50	60	1.5	2	2.5	3	4	5	6	10	15	20
SWL750	154	136	130	106	90.0	77.0	59.2	44.7	38.3	35.5	26.2	21.8	17.1	14.6	11.0	9.17	7.58	5.33	3.66	2.80
SWL780V	166	141	132	105	89.1	75.8	57.1	47.6	40.6	35.8	25.9	20.4	17.1	14.7	11.4	9.37	7.99	5.14	3.55	2.72
SWL1100	228	196	185	151	132	110	83.8	70.5	60.8	51.7	38.2	30.2	25.5	22.3	17.8	14.8	12.8	8.50	5.84	4.46
SWL1800	327	309	301	271	231	191	141	116	98.3	85.2	60.3	48.5	41.3	36.0	29.0	23.7	20.0	12.4	8.67	6.68
SWL1850	279	262	256	236	218	180	141	117	102	89.7	65.7	51.7	43.3	37.7	30.3	25.7	22.0	15.0	10.3	7.88
SWL2250	453	372	350	293	253	213	165	137	117	104	77.5	62.8	52.7	45.8	36.9	31.2	26.8	18.2	12.5	9.58
SWL2300/E	361	359	332	270	234	211	171	138	116	101	73.3	58.4	49.0	42.3	33.4	27.5	23.4	14.8	9.89	7.42
SWL2500/E	502	452	432	368	290	276	205	164	138	120	87.3	68.3	56.9	47.6	39.2	33.2	28.8	18.5	12.5	9.49
SWL3300	471	470	446	400	335	291	234	194	163	141	103	81.7	68.8	60.3	47.5	39.3	33.5	20.9	14.4	11.2
SWL3800	602	600	574	473	392	337	260	211	180	158	119	94.5	78.6	67.7	52.9	43.3	36.5	22.7	16.0	12.6
SWL4250	683	681	635	523	442	389	307	253	217	189	139	111	93.4	80.7	63.4	52.4	44.6	28.2	19.6	15.1
SWL1850-6	423	412	406	384	357	329	252	214	186	164	126	102	85.7	74.6	60.0	50.9	43.6	29.7	20.4	15.6
SWL2500-6	727	725	673	589	519	463	368	306	265	232	167	134	113	96.3	73.6	60.3	51.4	32.6	21.7	16.3

Charging

The performances and service life of batteries depend directly on the efficiency of the charge.

Floating charge

To recharge and correctly maintain the charge of these batteries, we recommend constant voltage charge at 2.275V +/-1% per cell (at 20°C). At this voltage, no charge current limitations are necessary. The batteries will limit the current point ($<2 \times C_{20}^{*max}$) at the start of charging.

The ripple current must be limited to $0.1 C_{20}^{*}$.

It should be noted that for batteries connected in series, dispersion of floating voltages for each monobloc, caused by gas recombination, may be observed.

This dispersion may be of +6% / -3% at the start of the battery's life and +/- 2% after 6 months of use.

Fast charge

To recharge batteries more quickly, charge them at constant voltage of 2.35 V to 2.50V +/-1% per cell.

Particular precautions for avoiding overload :

- at this voltage level, the charge current should be limited to $0.25C_{20}^{*}$.
- the fast charge should be stopped when the charge current has reduced to less than $0.07C_{20}^{*}$ and must not continue for more than 20h before switching to float charge mode.

Charging time

For a charge limited to $0.1C_{20}^{*}$ or $0.25C_{20}^{*}$, the floating recharge time for completely discharged batteries (100% of the depth of the discharge) is approximately 72 hours.

In fast charge, the recharge time for completely discharged batteries cannot be less than 4 hours.

For different charge methods, figures 2, 3, 4 and 5 show the voltage rate, current and volume of the charge of the batteries in relation to time.

It should be noted that the charge volume :

- must reach 110 to 115% of the charge to obtain 100% of the capacity available.
- will be greater, for a given time, at high temperatures and lesser at lower temperatures.

*: C_{20} represents the capacity of the battery in 20h (final voltage = 1.75V/cell)

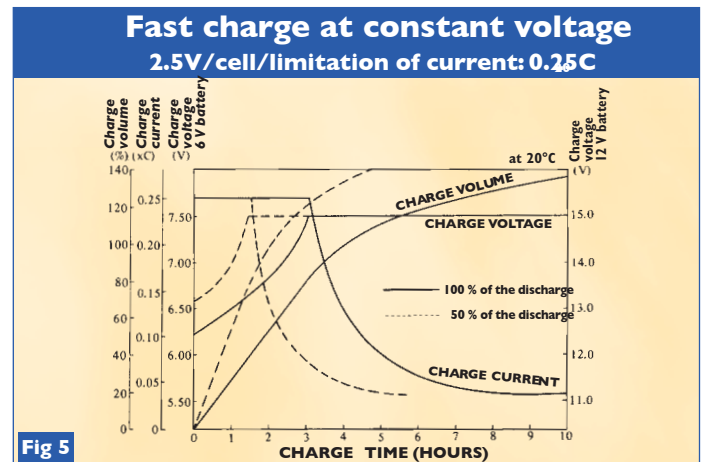
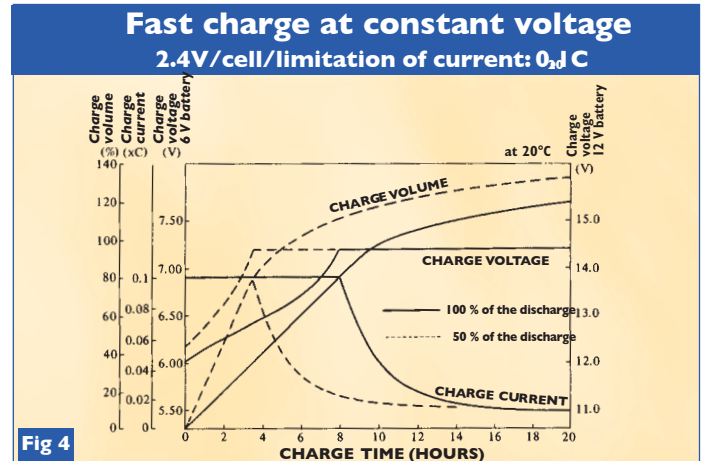
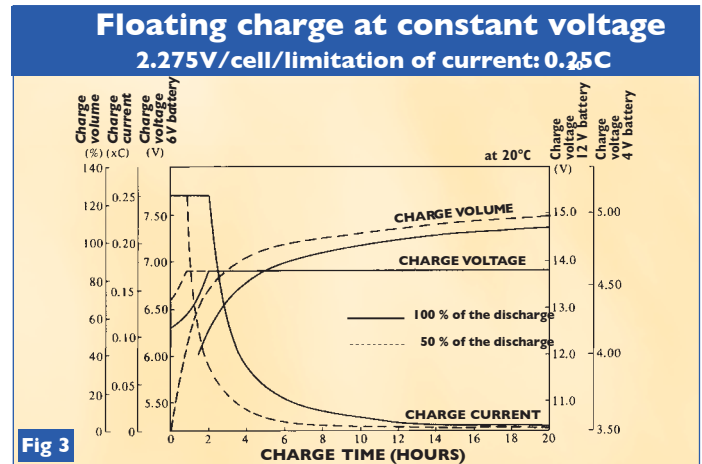
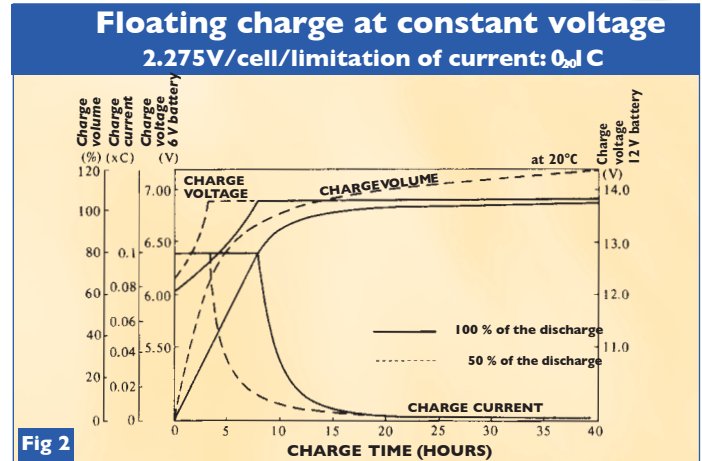



Temperature compensation

In order to optimise the service life of batteries, it is important to avoid all overcharge at high temperatures (risk of thermal runaway) or undercharge at low temperatures. Externally, for example, it is advised that the floating charge voltage be at $-3\text{mV}/^\circ\text{C}/\text{cell}$ for temperatures of more than 25°C and $+3\text{mV}/^\circ\text{C}/\text{cell}$ for temperatures of less than 15°C (central point $2.275\text{V}/\text{cell}$ at 20°C). For temperatures of more than 45°C , it is advised that the charge be stopped.

Noted that temperature sensor must be installed close to the batteries (consult Yuasa).

If the battery temperature is constant, (internally for example) and the charger has not been compensated, adjust the floating voltage in relation to the temperatures of the batteries.



Discharge

Determining your battery

To determine your batteries in relation to the power or discharge current (at 20°C) and the expected autonomy, use the tables on pages 4, 5 and 6.

After any discharge, recharge your batteries as soon as possible.

Final discharge voltage / deep discharge

Fig 6 shows the evolution of battery voltage in relation to the regimes and discharge times (autonomy).

The dotted line indicates the minimum recommended discharge voltage. In order to avoid deep discharge and deterioration of the batteries by plate sulfation, do not go below this final voltage.

If the batteries are accidentally discharged below this limit, recharge them as soon as possible.

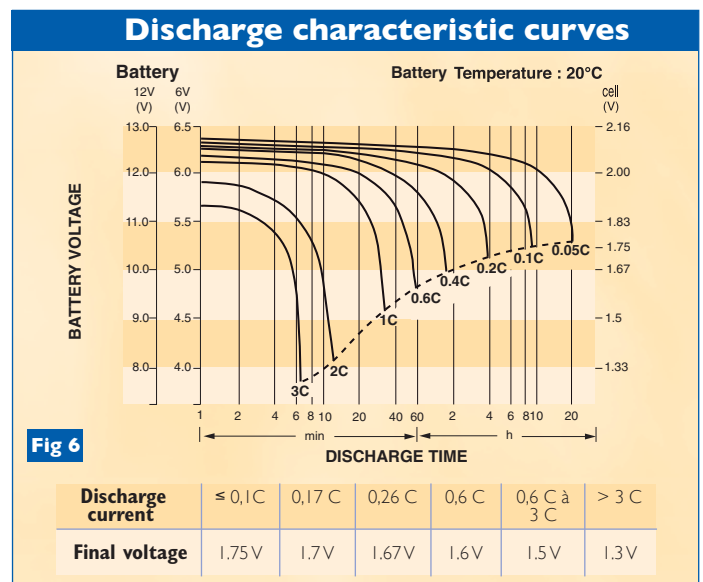

Capacity and temperature

The capacity of the batteries evolves in relation to temperature. The table below indicates the correction coefficient for capacity in relation to temperature and to discharge autonomy. This should be taken into account when determining your batteries.

Ex : Capacity at 5°C for 35 mn autonomy = capacity at 20°C x 0,85 (same for current and power).

AUTONOMY (mn)	-20°C	-15°C	-10°C	-5°C	0°C	+5°C	+10°C	+15°C	+20°C	+25°C	+30°C	+35°C	+40°C	+45°C	+50°C
1200	0,760	0,790	0,820	0,850	0,880	0,910	0,940	0,970	1,000	1,030	1,048	1,053	1,058	1,063	1,068
540	0,760	0,790	0,820	0,850	0,880	0,910	0,940	0,970	1,000	1,030	1,048	1,053	1,058	1,063	1,068
240	0,760	0,790	0,820	0,850	0,880	0,910	0,940	0,970	1,000	1,030	1,048	1,053	1,058	1,063	1,068
180	0,760	0,790	0,820	0,850	0,880	0,910	0,940	0,970	1,000	1,030	1,048	1,053	1,058	1,063	1,068
60	0,600	0,650	0,700	0,750	0,800	0,850	0,900	0,950	1,000	1,050	1,076	1,086	1,091	1,096	1,100
35	0,600	0,650	0,700	0,750	0,800	0,850	0,900	0,950	1,000	1,050	1,076	1,086	1,091	1,096	1,100
13	0,600	0,650	0,700	0,750	0,800	0,850	0,900	0,950	1,000	1,050	1,076	1,086	1,091	1,096	1,100
6	0,600	0,650	0,700	0,750	0,800	0,850	0,900	0,950	1,000	1,050	1,076	1,086	1,091	1,096	1,100

Self discharge

The self discharge level of SWL batteries is approximately 3% per month for storage at 20 °C. The self discharge level increases with high temperatures (see fig.7). Batteries should be stored in a dry place at an ambient temperature. To prevent any deterioration or any difficulty in recharging the battery, storage times should be limited.

The table below indicates maximum storage time in relation to temperature.

STORAGE TEMPERATURE	MAXIMUM STORAGE TIME
0° C to 25°C	12 months
25°C to 30°C	9 months
31°C to 40°C	5 months
41°C to 50°C	2.5 months

Once the storage limits have been reached, the batteries should be recharged at 2.4V/cell (current limited to 0.25C₂₀) for 24 hours in order to compensate for the loss of capacity associated with the self discharge.

Open circuit voltage and remaining capacity

The remaining capacity of the batteries can be determined empirically by measuring its open circuit voltage after a minimum of 24 h rest (see fig.8).

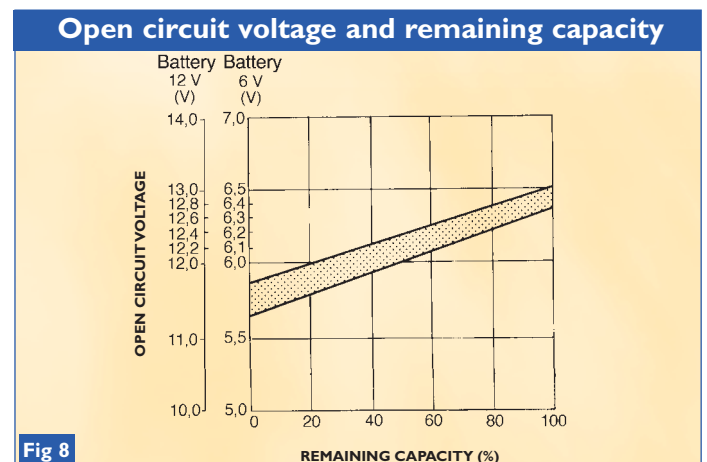
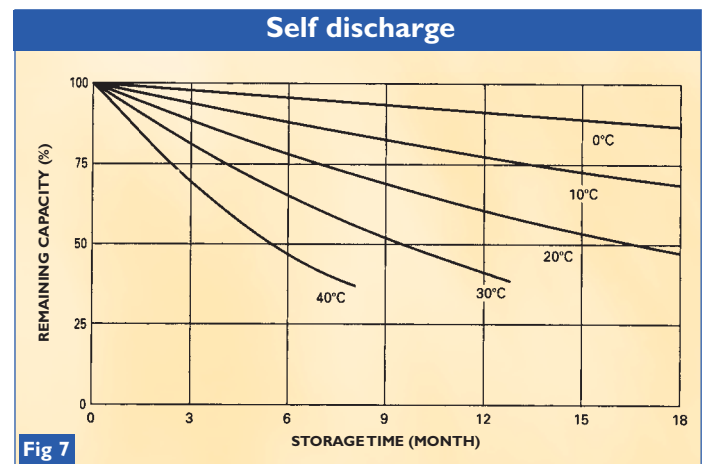

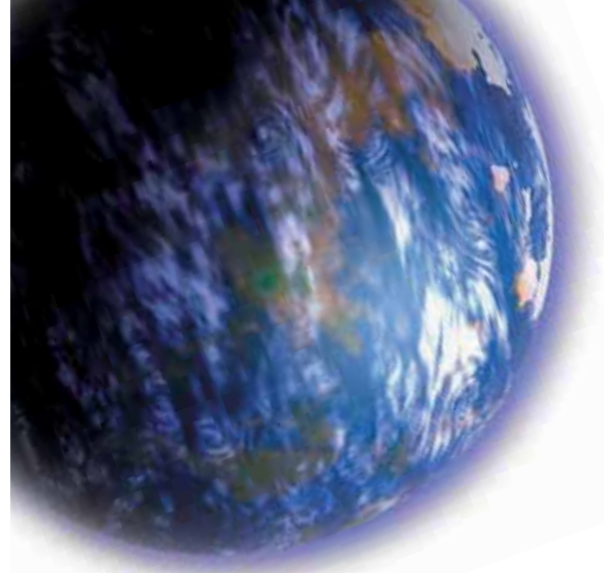

Service life in floating

The SWL type batteries are designed to work for 10 years in floating and normal usage conditions:

Floating voltage: 2.275V/cell (at 20°C).

Temperature less than or equal to 20°C.

Floating use (estimated discharged 100% every 3 months approx.).

For evolution of capacity over time, see fig.9.

It should be noted that the service life of the batteries is directly affected by:

- Batteries temperature, (see fig.10). The service life of batteries is divided by 2 for every band of 10 °C over 20°C. It should be noted that compensating for the floating voltage in relation to the temperature reduces the loss of service life by 20%.
- floating voltage (see fig.11).
- number of discharges
- depth of discharge and non respect of the final voltage.
- poor current charge quality.

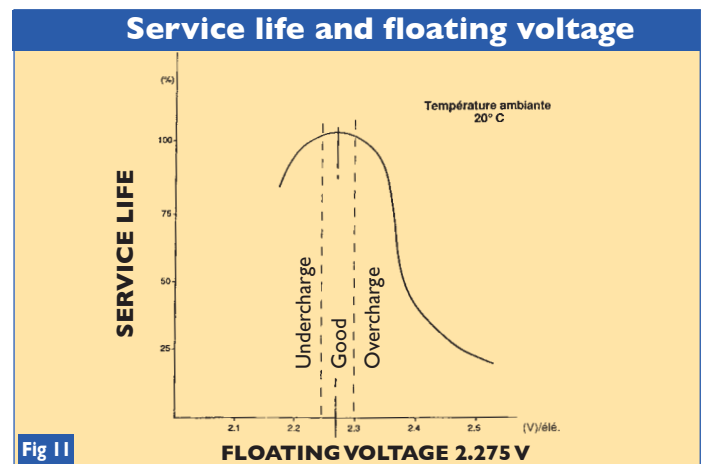
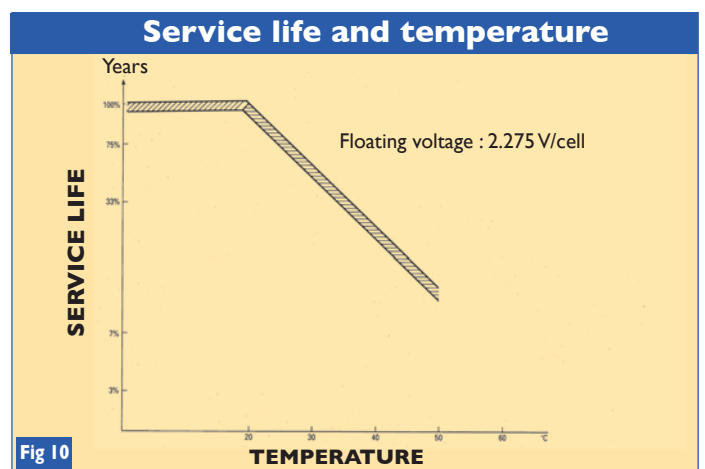
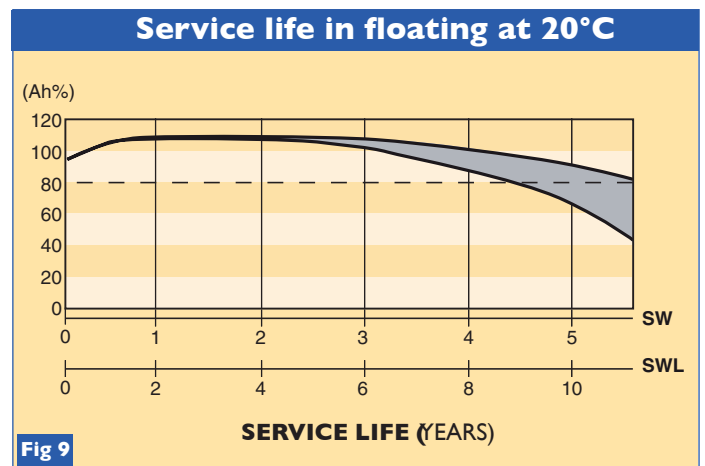

Temperature

For the charge:

20°C advised, limit -15°C to +50°C.

For the discharge:

20°C advised, limit -15°C to +60°C.

For storage:

0 to 20°C advised, limit -20°C to +50°C.

Standards

The SWL batteries:

Conform to or are compatible with the following standards:
IEC60896-21/22, BS6290-4, UL94V0/HB, IEC61056 .

Referenced UL n°MH28018.

Manufactured with ISO9001 (2000) quality systems and
ISO14001 environment management system.

Eurobat : 10-12 years (High Performance).

WEEE/ROHS : directives 2002/96/EC et 2002/95/EC, batteries
excluded and subject to 91/157/EC.



Transport

IATA classification: class 8, group 3, UN2800 **A67**
(non-dangerous material).

Rules of use

People handling the batteries must be authorised to work with
electrical equipment (in accordance with the UTE C 18-510
in France or local equivalent standard).

The terminals must never be short-circuited. Insulated tools
which meet applicable standards must be used.

The batteries must not be used in an enclosed space and
natural ventilation is necessary, in accordance with the
standard EN50272-2 or NFC15-100.

We recommend, a space of 5 to 10 mm must be left between
the batteries for ventilation.

In order to connect several monoblocs, safety cabling must be
used, avoiding any differences in potential close, and all risk of
electric shock.

The section and length of the connectors must be
appropriate to the maximum current.

Respect the tightening torque of the terminals (see page 3).

The batteries are delivered charged, but it is recommended that
they be recharged in floating for 72 h before any discharge.

Don't fit the batteries by the handles.

Environment

Recovery and recycling of used batteries in accordance
with the governmental directives in force.

Service

Verify the cleanliness of the batteries and connectors.

Clean the batteries with a damp cloth. Do not use solvents.

Every three months, verify that the total voltage of the
batteries is equal to $2.275V \times N$ cells in series for a
temperature of 20 °C.

Make an annual check of the individual voltage of each
monobloc. Dispersion of + or - 2%, caused by gas
recombination may be observed.

An autonomy test can be performed once a year, either by
discharge or by measuring the impedances.

Installation

Our departments are at your disposal for any further information and proposals concerning:

Supplies of batteries assembled in cabinets or on metallic or wooden stands, with adapted connection equipment, accessories and plans of the wiring assembly.

On site assembly and wiring by qualified and authorised installers.



Distributed by :



Yuasa Batteries France

ZAC des Chesnes Ouest
13 rue du Morellon,
38070 Saint Quentin-Fallavier,
France.

Tel. 04 74 95 90 90

Fax 04 74 95 90 91

info@yuasa.fr

www.yuasa.fr

V15-01/2016