

**JLP-L2S FINGERTIP PROPORTIONAL CONTROL LEVER**

**FEATURES**

- Single axis / bidirectional, panel mounting style.
- 3-4 pins potentiometer configuration.
- Bidirectional switches.

**MECHANICAL SPECIFICATIONS**

Lever deflection angle:	$\pm 32^\circ \pm 1^\circ$
Electrical angle:	$\pm 30^\circ \pm 1^\circ$
Operating temperature range:	$-25^\circ\text{C} / +85^\circ\text{C}$
Protection class:	IP 65 (above panel)
Life:	3 million cycles
Fixing screws included:	2 - M4x16

**ELECTRICAL SPECIFICATIONS**

**Potentiometer**

Electrical power rating:	0.25 W @ 25°C
Ohmic resistance: / A = 50% of $V_{in}$	8 k $\Omega$ $\pm 20\%$
/ Q = 80% of $V_{in}$	5 k $\Omega$ $\pm 20\%$
/ R = 100% of $V_{in}$	4 k $\Omega$ $\pm 20\%$
Max. operating input voltage ( $V_{in}$ ):	48 V or $\pm 24$ V
Min. load impedance on pin 5 (signal):	50 k $\Omega$
Max. operating current on pin 5:	1 mA
Output voltage:	see graph
Linearity (resistive track):	2% or better

**Directional switches**

Typical track resistance:	150 Ohm
Max. operating input voltage:	48 V or $\pm 24$ V
Min. load impedance on pins 2&3:	50 k $\Omega$
Max. operating current on pins 2&3:	1 mA
Directional switches threshold angle:	$\pm 4^\circ$
Connector type: Mod. D Dubox = P.N. 76382.407 wiring	
Mod. G Molex = C-Grid P.N. 50-57-9407	

**POTENTIOMETER & SWITCHES OPTIONS**

**Reference codes**

Output signal	S= 80% $V_{in}$	S= 100% $V_{in}$	S= 50% $V_{in}$
3-4 pins pot & bidir. switch	Q	R	C

**ELECTRICAL CONNECTIONS**

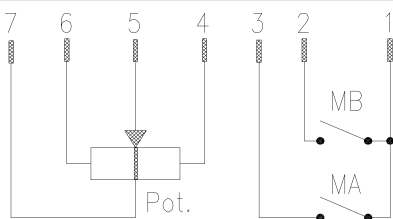

**OVERALL DIMENSIONS**

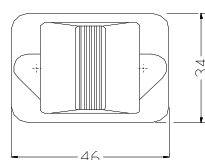
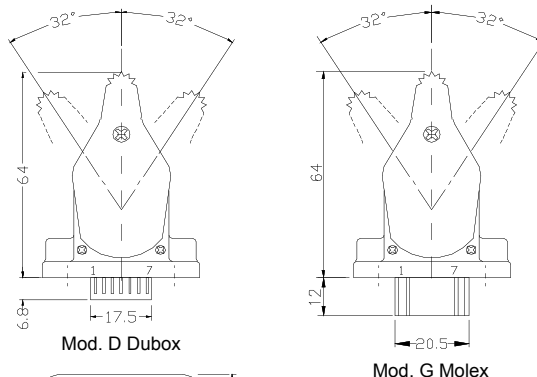

**PANEL CUT-OUT**

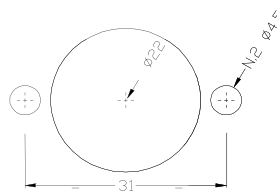

**OUTPUT SIGNAL CONTROL CHARACTERISTIC**

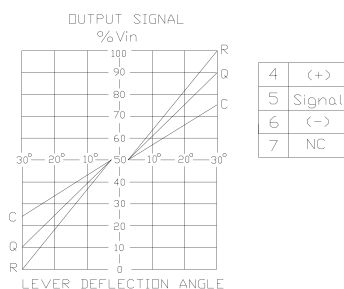

3-pins configuration wiring

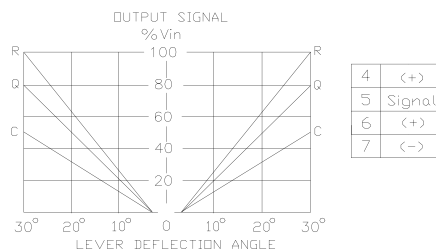

4-pins configuration wiring

**JLP ORDERING INFORMATION: see page JK6**

**WARNING:** the specifications/application data shown in our catalogs and data sheets are intended only as a general guide for the product described (herein). Any specific application should not be undertaken without independent study, evaluation, and testing for suitability.



4484 Boeing Drive Rockford, IL 61109 • USA • Phone +1 (815) 397-6628 • Fax +1 (815) 397-2526  
 mail: delta@delta-power.com • www.delta-power.com



Via Malavolti, 36 • 41122 Modena • ITALY • Phone +39 (059) 254895 • Fax +39 (059) 253512  
 mail: tecnord@tecnord.com • www.tecnord.com