

Surge Protection

for Low Voltage Power Systems

2013/14



ISKRA ZAŠČITE

BE ON THE SAFE SIDE



Dr. Otmar Zorn

PRESIDENT'S FOREWORD

Dear Reader,

We are pleased to introduce our 2013 catalogue of Surge Protective Devices (SPDs) intended for use on low voltage power distribution systems. This edition presents many new products and innovations, including the patented SAFETEC® and ProGRID® series which we believe are revolutionizing safety and performance in the power quality industry.

ISKRA ZAŠČITE is a leading designer and manufacturer of surge protection products with a strong customer-oriented culture fostered throughout the company. We believe a comprehensive understanding of our customers' needs and of the industry in which they operate is crucial to our ability to develop effective products and solutions.

Our success in bring you the best products we can, is driven by our people and their commitment to excellence. These attributes are encouraged in all aspects of our operations - from our qualified research and development engineers many of whom hold higher degrees, to our dedicated manufacturing staff and continuing education programs which ensure skill-sets keep pace with our newer process control capabilities and automated test equipment.

As a leader in our industry, we believe we share responsibilities beyond those we owe to our customers and partners (to ensure our dealing adhere to the highest standards of business integrity) and beyond those we owe to our employees (to ensure a safe and pleasant working environment), but we also owe an obligation to care for our environment and to minimize the impact we have upon it.

We are proud of the many ways in which we work to safeguard this. Our products are RoHS compliant, our manufacturing facility is currently ISO 9001 certified and we are now in the advanced stage of moving towards ISO 14001. We also believe that we owe an obligation to give back to our industry as a whole. This we do through such activities as educational seminars and participation in standardization committees.

With our strong customer focus, stringent quality measures, compliance to relevant safety and performance standards, comprehensive testing and manufacturing facilities and good relations with suppliers, we are reassured that ISKRA ZAŠČITE and its products are well placed to face the demands of our evolving electrical industry with its growing sensitivity to overvoltages surges and transients.

President and Owner

Ljubljana, Slovenia, EU, 2013

Contents

Introduction

5

Class I, II Compact Single and Multi-pole SPD 12.5kA per pole

11

SAFETEC B(R) TCG Series; SAFEBLOC B(R) TCG Series



Class I, II Compact Single and Multi-pole SPD 25kA per pole

21

SAFETEC B(R) TCG Series; SAFEBLOC B(R) TCG Series



Class I, II Compact Single-pole SPD 35kA and 50kA

33

SAFETEC B(R) 35 TCG, SAFETEC B(R) 50 TCG



Class I, II Compact Single and Multi-pole SPD 12.5kA per pole

37

PROTEC B2N(R) Series; PROBLOC BS(R) Series



Class I, II Compact Single and Multi-pole SPD 25kA per pole

51

PROTEC BS(R) Series; PROBLOC BS(R) Series



Class I, II Compact Single-pole SPD 35kA and 50kA per pole

65

PROTEC BS(R) 35, PROTEC BS(R) 50; PROBLOC BS(R) 100 (1+1)



Class I, II Modular Single and Multi-pole SPD 12.5kA per pole

71

PROTEC B2S(R) Series



Class II Modular Single and Multi-pole SPD 40kA per pole

79

SAFETEC C(R) Series



Class II Modular Single and Multi-pole SPD 50kA per pole

89

SAFETEC C(R) - UL Series



Class II Modular Single and Multi-pole SPD 40kA per pole

95

PROTEC C(R) Series



Class II Single-pole SPD 20kA and 40kA

105

PROTEC C(R) Series - variations



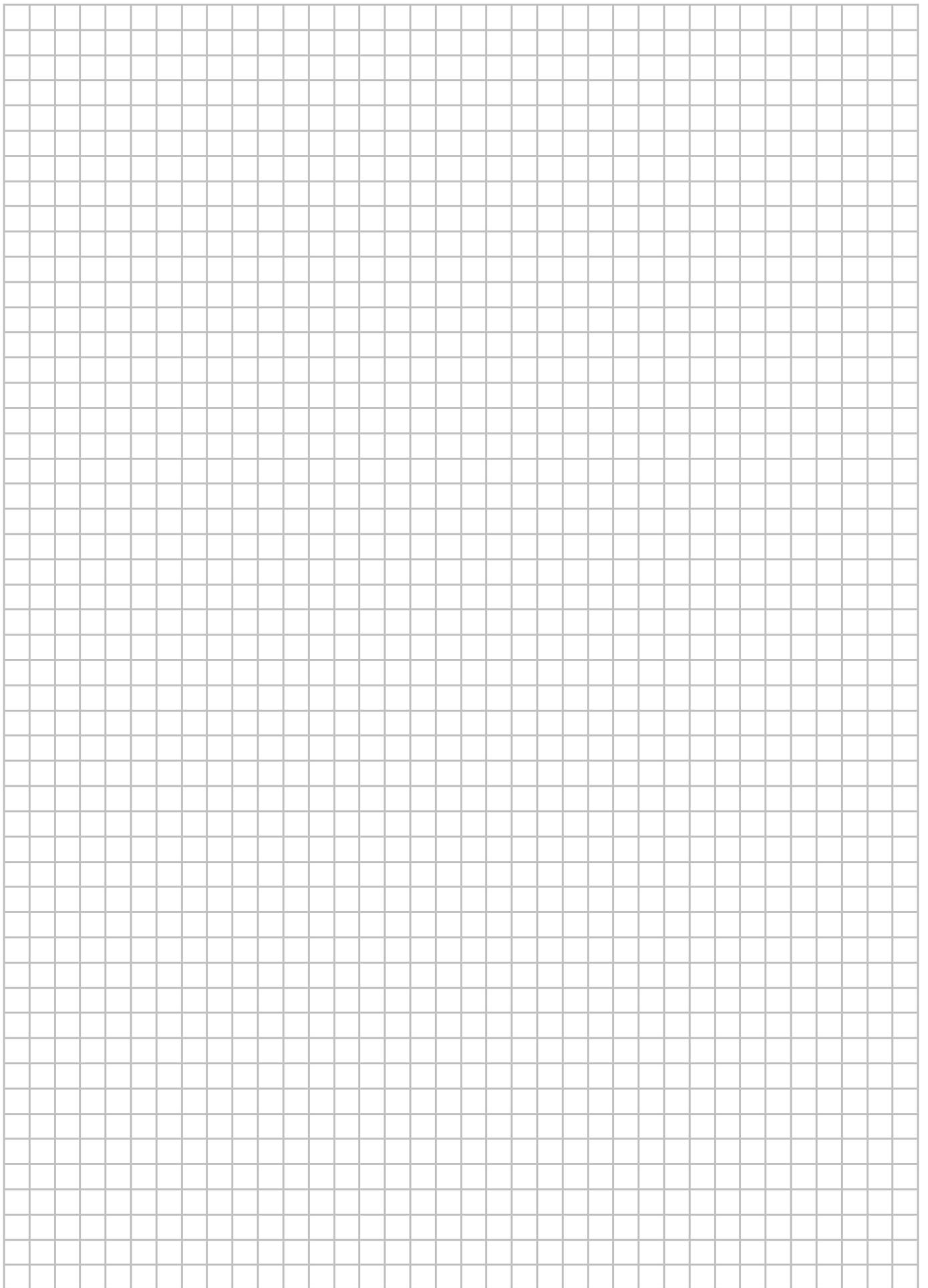

Contents

	Class II Modular Multi-pole SPD 20kA and 40kA per pole PROTEC CMG(R) 40, PROTEC CM(R) 80 Series	117
	Class III Modular and Compact Single and Multi-pole SPD PROTEC D(R), DM(R), DMG(R), MPE-MINI, MPE-MINI LED, ZE 200, VTC 10, PROFILT D, PROLED 275 16A Series	125
	Modular and Compact SPD for DC power systems DC PROTEC B(R), DC PROTEC C(R), PROTEC C(R), PROTEC CN(R), PROTEC DMDR, VM-DC, SMH-PS	139
	Class I, II SPD for Photovoltaic systems SAFETEC B(R) PV TCG Series, SAFETEC C(R) PV Series, SAFETEC C(R) PV UL Series, PV PROTEC C(R) series	147
	Class I, II SPD for Wind systems SAFETEC B(R) WT TCG Series, SAFETEC C(R) WT Series, SAFETEC C(R) WT UL Series	161
	PV Combiner Boxes PVCB I, PVCB II Series	169
	AC Boxes PB Series, PROFILT PSF Series	173
	Class II SPD for overhead power lines PROTEC AQ, AQS	177
	Isolating spark gap (ISG) for Equipotential Bonding EPZ 100, EPZ 100 Ex	181
	Connection Accessories	185
	ProGRID series - Power Quality Accessories Surge and Lightning counter family - ProSEC I, II, II+, III, ProLEC I SPD Life-status Monitoring Accessories - ProALARM I, II, ProALYSER, ProSTE, ProSL5	191
	Product index	203

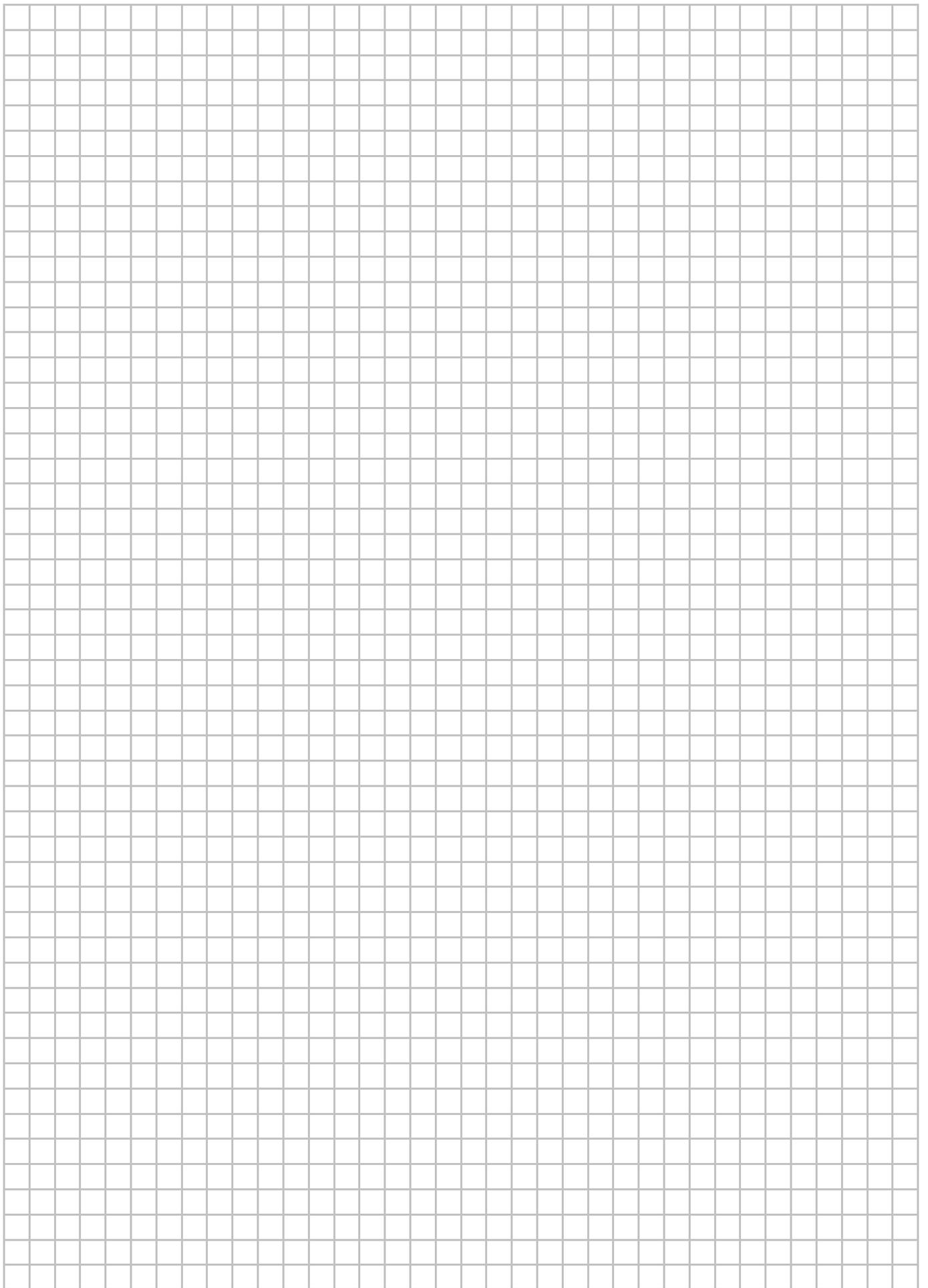

TN-S system

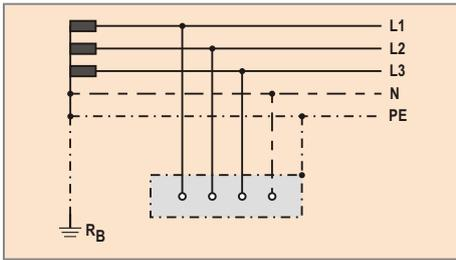

IEC 364-4-41 (1992) designates low voltage distribution systems (networks) using two letters. The first letter describes the grounding method used at the source (i.e. the secondary side of the power distribution transformer). The second letter describes the grounding method used at the consumer's electrical installation for any conductive metal parts.

This method is used to define three basic systems:

- TN** system;
- TT** system;
- IT** system.

Where the abbreviations have the following meaning:

First letter - grounding method used at the source:

- T** direct connection to ground of the power supply source (star point of transformer secondary winding).
- I** isolation of power supply source from ground, or connection via a high impedance.

Second letter - grounding method used at exposed conductive parts in the electrical installation:

- T** exposed conductive parts are directly grounded independent of the eventual existing grounded feeding point
- N** exposed conductive parts are directly connected to the ground electrode (grounding resistor)

Subsequent prefixes may be used to describe the arrangement of neutral and protective conductors:

- S** neutral and protective conductor are separated
- C** neutral and protective conductor are connected

Hence it follows that there are three possible TN sub-systems: TN-S, TN-C and TN-C-S.

Various protective devices may be installed on different distribution systems:

- Over-current protective device (CB, fuses etc),
- Residual protective device (RCD, GFI)
- Insulation monitoring device
- Fault-voltage-operated protective device
- Surge Protective Devices (SPDs)

It is important to ensure that an SPD is correctly selected and co-ordinated with the type of power system used and any over-current protection devices installed. The following protective devices are encountered in the power systems shown:

TN System

- Over-current protective device;
- Residual current protective device

TT System

- Over-current protective device;
- Residual current protective device
- Voltage fault detector

IT System

- Over-current protective device;
- Residual current protective device
- Insulation monitoring device
- Fault-voltage-operated protective device
- Voltage fault detector

TN-C system

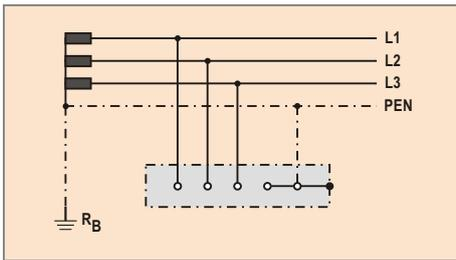

TN-C-S system

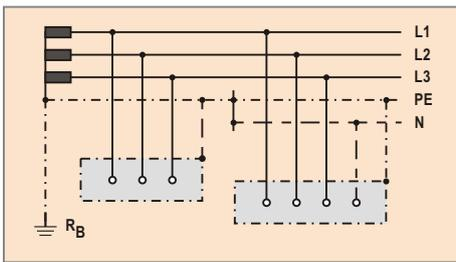

TT system

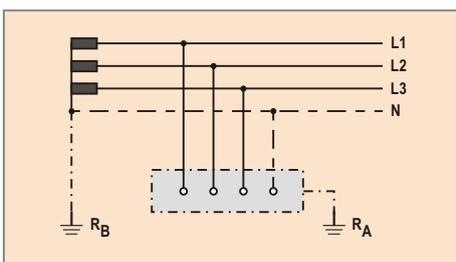

IT system

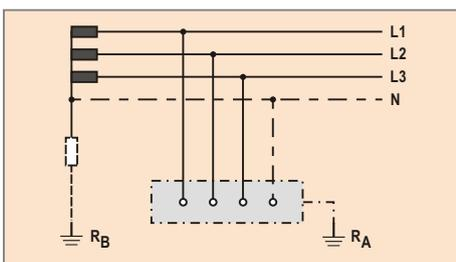

Common Power Distribution Systems (North America, Asia, Latin America)

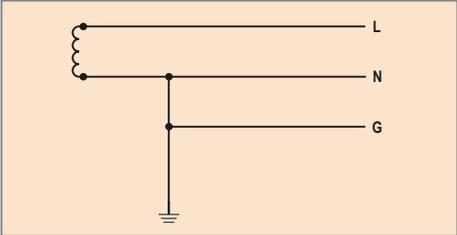
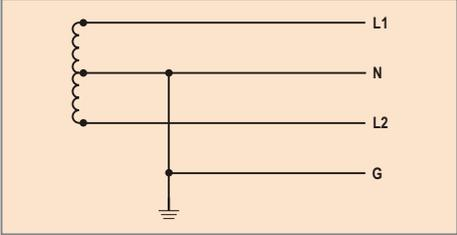
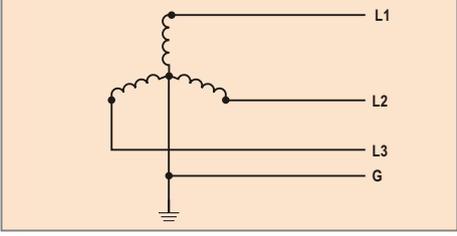
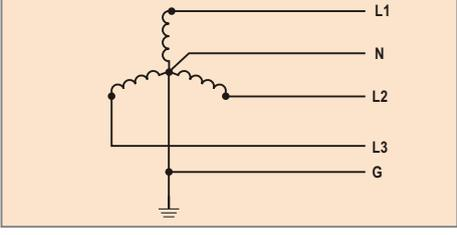
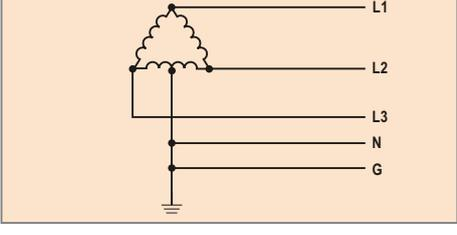
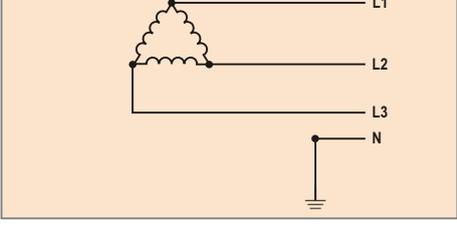
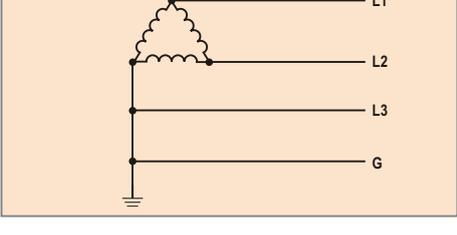
Source Configuration	Description	Typical Supply Voltages
	Single-phase 1Ph, 2W+G	110V, 120V, 220V, 240V (L-N)
	Single-phase 1Ph, W+G Also known as Split phase or Edison system	120/240V (L-N / L-L)
	3-phase WYE without neutral 3Ph Y, 4W+G	480V (L-L)
	3-phase WYE with neutral 3Ph Y, 4W+G	120/208V, 220/380V 230/400V, 240/415V 277/480V, 347/600V (L-N / L-L)
	Delta High Leg 3Ph, 4W+G	120/240V (L-N / L-L)
	Delta Ungrounded 3Ph, 3W+G	240V, 480V (L-L)
	Delta Grounded Corner 3Ph, 3W+G	240V, 480V (L-L)

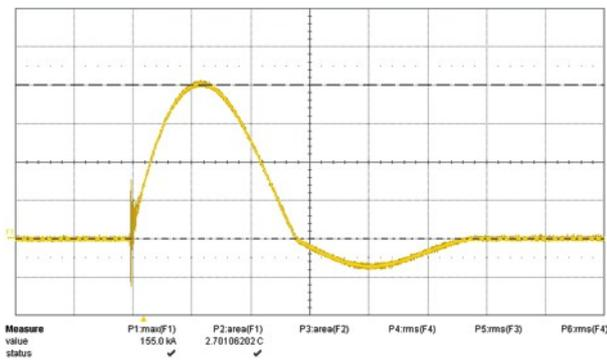
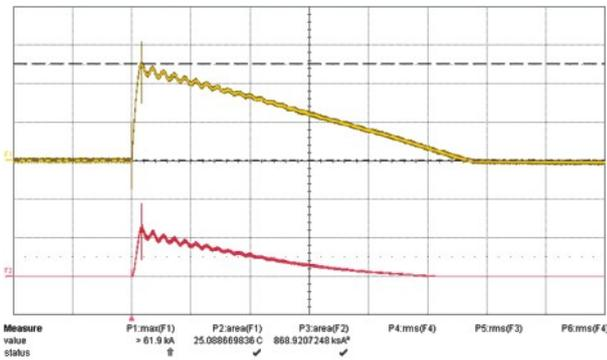
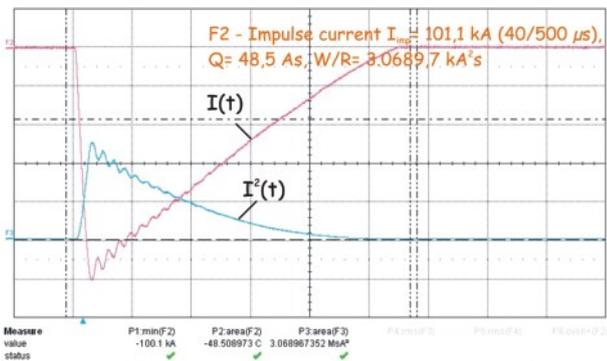
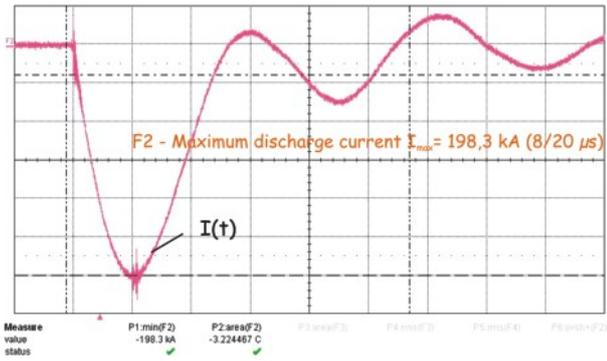

Surge Protective Device SPD

A device that is intended to limit transient overvoltages and divert surge currents. It contains at least one nonlinear component.

Maximum continuous operating voltage U_c

The maximum r.m.s. or d.c. voltage, which may be continuously applied to the SPD's mode of protection.

Voltage protection level U_p

A parameter that characterizes the performance of the SPD in limiting the voltage across its terminals, which is selected from a list of preferred values. This value shall be greater than the highest value of the measured limiting voltages.

Residual voltage U_{res}

The peak value of voltage that appears between the terminals of an SPD due to the passage of discharge current temporary overvoltage test value.

Nominal discharge current I_n

The crest value of the current through the SPD having a current waveshape of 8/20. This is used for the classification of the SPD for class II test and also for preconditioning of the SPD for class I and II tests.

Impulse discharge current for class I test I_{imp} (10/350 current impulse)

The crest value of discharge current through the SPD with specific charge transferred Q and specified energy W/R in the specified time.

Combination wave

The combination wave is delivered by a generator that applies a 1.2/50 voltage impulse across an open circuit and an 8/20 current impulse into a short circuit. The voltage, current amplitude and waveforms that are delivered to the SPD are determined by the generator and the impedance of the SPD to which the surge is applied. The short-circuit current is symbolized by I_{SC} . The open-circuit voltage is symbolized by U_{OC} .

TOV Characteristics

Is a behavior of a surge device which is exposed to a temporary overvoltage for a certain time duration. The time can be between 5 seconds and a few weeks.

Combined Arresters

Overvoltage protection device consisting of lightning current arresters and surge arresters.

Maximum discharge current I_{max} for class II test

Crest value of a current through the SPD having an 8/20 waveshape and magnitude according to the test sequence of the class II operating duty test. I_{max} is greater than I_n .

1.2/50 voltage impulse

Voltage impulse with a virtual front time of 1.2 μ s and a time to half-value of 50 μ s.

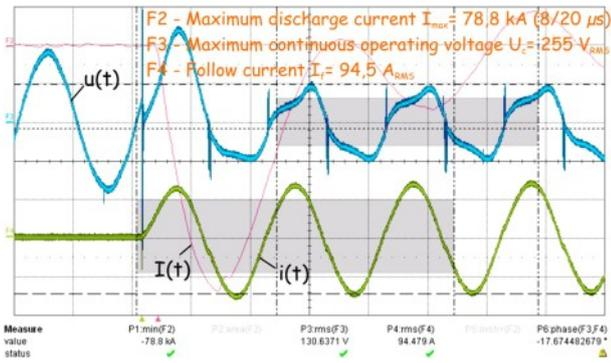

8/20 current impulse

Current impulse with a virtual front time of $8\mu\text{s}$ and a time to half-value of $20\mu\text{s}$.

Environmental protection provided by enclosure (IP code)

The extent of protection provided by an enclosure against access to hazardous parts, against ingress of solid foreign objects and/or against ingress of water (see IEC 60529).

SPD disconnecter

Device (internal and/or external) required for disconnecting a SPD from the power system.

Follow current interrupt rating I_{fi}

Current supplied by the electrical power system and flowing through the SPD after a discharge current impulse. The follow current is significantly different from the continuous operating current I_c .

Back-up fuse

Overcurrent device (for example, circuit-breaker or fuse), which could be part of the electrical installation located externally upstream of the SPD.

Varistor (MOV)

A varistor is a bipolar, non-linear resistor with a symmetrical voltage-current characteristic, where the resistance decreases with an increasing characteristic curve.

Mode of protection of an SPD

An intended current path, between terminals that contains protective components, e.g. line-to-line, line-to-earth, line-to-neutral, neutral-to-earth.

Multipole SPD

Type of SPD with more than one mode of protection, or a combination of electrically interconnected SPDs offered as a unit

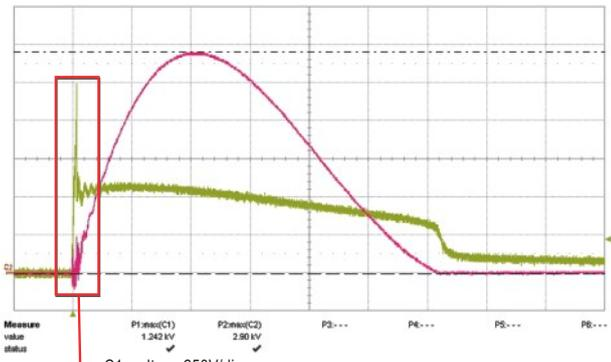
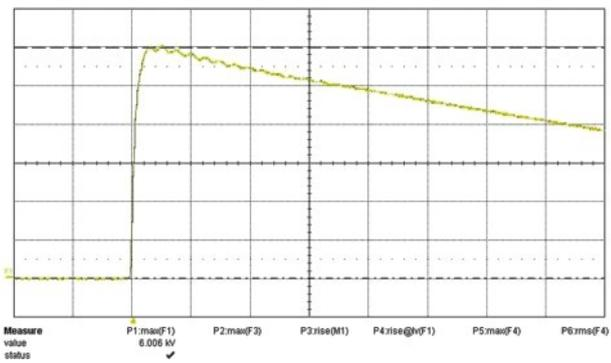

C1: voltage 250V/div
 C2: current 500A/div
 Timebase: $5\mu\text{s/div}$

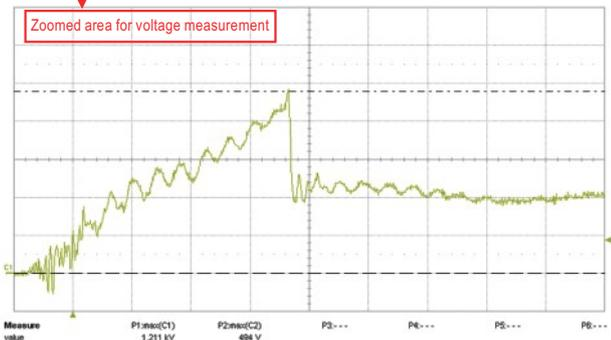

C1: voltage 250V/div
 Timebase: 100ns/div

Regulations

1. IEC/EN 61643-11:2011 (VDE 0675-6-11)	Surge protective devices connected to low voltage power distribution systems - Requirements and test methods;
2. IEC 61643-12:2008 (VDE 0675-6-12)	Surge protective devices connected to low voltage power distribution systems - Selection and application principles;
3. IEC 60364-5-53:2001 (VDE 0100-534)	Electrical installation of buildings - Part 5-53: Selection and erection of electrical equipment - isolation, switching and control;
4. IEC PAS 60099-7:2004	Surge arresters - Part 7: Glossary of terms and definitions from IEC publications 60099-1, 60099-4, 60099-6, 61643-11, 61643-12, 61643-21, 61643-311, 61643-321, 61643-331 and 61643-341;
5. IEC 61000-4-5:2005 (VDE 0847-4-5)	Electromagnetic compatibility (EMC) - Part 4-5: Testing and measurement techniques - Surge immunity test;
6. IEC 62305-1:2010 (VDE 0185-305-1)	Protection against lightning - Part 1: General principles;
7. IEC 62305-2:2010 (VDE 0185-305-2)	Protection against lightning - Part 2: Risk management;
8. IEC 62305-3:2010 (VDE 0185-305-3)	Protection against lightning - Part 3: Physical damage to structures and life hazard;
9. IEC 62305-4:2010 (VDE 0185-305-4)	Protection against lightning - Part 4: Electrical and electronic systems within structures;
10. ITU-T K.20:2008	Protection against interferences: Resistibility of telecommunication switching equipment to overvoltages and overcurrent;
11. ITU-T K.21:2008	Protection against interferences: Resistibility of subscriber's terminal to overvoltages and overcurrent;
12. ITU-T K.44:2011	Protection against interferences: Resistibility test for telecommunication equipment exposed to overvoltages and overcurrent - Basic Recommendation;
13. IEC 61643-21:2012 (VDE 0845-3-1)	Low voltage surge protective devices - Part 21: Surge protective devices connected to telecommunications and signaling networks - Performance requirements and testing methods;
14. IEC 61643-22:2004	Low-Voltage Surge Protective Devices - Part 22: Surge protection devices connected to telecommunications and signaling networks - Selection and application principles;
15. IEC 60099-1:1999 (VDE 0675-1)	Surge arresters - Part 1: Non-linear resistor type gapped surge arresters for a.c. systems
16. IEC 60099-4:2009 (VDE 0675-4)	Surge arresters - Part 4: Metal-oxide surge arresters without gaps for a.c. systems
17. IEC 60099-5:2000 (VDE 0675-5)	Surge arresters - Part 5: Selection and application recommendations;
18. IEC 60038:2009 (VDE 0175-1)	IEC standard voltages
19. UL 1449 3rd Edition	Standard for Surge Protective Devices
20. IEC 62497-2:2010	Railway applications - Insulation coordination - Part 2: Overvoltages and related protection
21. prEn 50526-1:2009	Railway applications - Fixed installations - D.C. surge arresters and voltage limiting devices - Part 1: Surge arresters
22. EN 50123-5:2003	Railway applications - Fixed installations - D.C. switchgear - Part 5: Surge arresters and low-voltage limiters for specific use in d.c. systems
23. EN 50122-1:1998	Railway applications - Fixed installations - Part 1: Protective provisions relating to electrical safety and earthing
24. IEC 60364-7-712:2002	Electrical installations of buildings - Part 7-712 : Requirements for special installations or locations - Solar photovoltaic (PV) power supply systems
25. HD 60364-7-712:2005	Electrical installations of buildings - Part 7-712: Requirements for special installations or locations - Solar photovoltaic (PV) power supply systems
26. EN 61173:2001	Overvoltage protection for photovoltaic (PV) power generating systems - guide32. SIST EN 61400-1:2006 /A1:2011 Wind turbines - Part 1: Design requirements (IEC 61400-1:2005/A1:2010)
27. IEC TR 61400-24:2010	Wind turbine generator systems - part 24: Lightning protection
28. prEN 50539-12:2012	Low-voltage surge protective devices - Surge protective devices for specific application including d.c. - Part 12: Selection and application principles - SPDs connected to photovoltaic installations
29. EN 50539-11:2012	Low-voltage surge protective devices - Surge protective devices for specific application including d.c. - Part 11: Requirements and tests for SPDs in photovoltaic applications
30. IEC 61643-311	"Components for low-voltage surge protective devices Part 311: Performance requirements and test circuits for gas discharge tubes (GDT)", Edition 2.0, 2013-04.
31. HD 60364-4-443:2006	Electrical installations of buildings - Part 4-44: Protection for safety - Protection against voltage disturbances and electromagnetic disturbances - Clause 443: Protection against overvoltages of atmospheric origin or due to switching.
32. EN 50164-3:2006	Lightning Protection Components (LPC) - Part 3: Requirements for isolating spark gaps
33. IEC 62561-3:2012	Lightning protection system components (LPSC) - Part 3: Requirements for isolating spark gaps (ISG)
34. IEC/EN EN 62561-6:2011	Lightning protection system components (LPSC) - Part 6: Requirements for lightning strike counters (LSC)
35. IEC/EN 61326-1:2013	Electrical equipment for measurement, control and laboratory use - EMC requirements - Part 1: General requirements

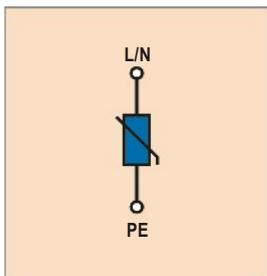

SPD comprising MOV:

- no problems with follow current I_{fi}
- quick response time $t_A (\leq 25\mu s)$ means low residual voltage
- responds well to low overvoltages
- high surge capacity, up to 50kA 10/350 μs

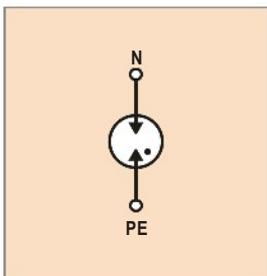

SPD comprising GDT:

- high surge capacity 100kA 10/350 μs
- no exhausting of ionised gases
- used in TT systems as galvanic separation between N-PE conductors

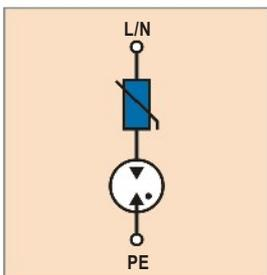

Hybrid SPD comprising both MOV and GDT:

- no follow current I_{fi}
- quick response time $t_A (\leq 25\mu s)$ means low residual voltage
- responds well to low overvoltages
- high surge capacity, up to 25kA 10/350 μs

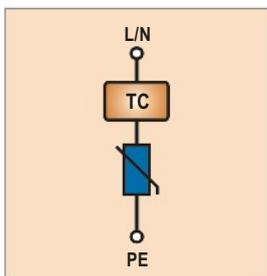

Hybrid SPD TC:

- no follow current I_{fi}
- quick response time $t_A (\leq 25\mu s)$ means low residual voltage
- responds well to low overvoltages
- high surge capacity, up to 25kA 10/350 μs
- TC - thermal Control Function

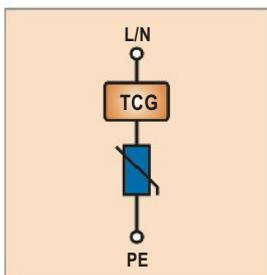

Hybrid SPD TCG:

- no follow current I_{fi}
- quick response time $t_A (\leq 25\mu s)$ means low residual voltage
- responds well to low overvoltages
- high surge capacity, up to 25kA 10/350 μs
- TCG - thermal Control Function without leakage current

Class I, II Compact Single and Multi-pole SPD 12.5kA per pole



Category IEC / EN / VDE:	Class I, II / Type 1, 2 / B, C
Location of use:	Main distribution boards
Protection modes:	L/N-PE, L-PEN, L-N, N-PE
Protective elements:	High energy MOV and GDT
Surge discharge rating:	$I_{imp} = 12.5kA$
Safety:	TOV immunity
Internal protection:	Separate thermal disconnecter for each MOV
Complies with:	IEC/EN 61643-11, UL 1449 3rd Ed.

The new SAFETEC B(R) TCG* and SAFEBLOC B(R) TCG* series of SPDs :

- Have no impact on the network in normal operation due to no leakage current design
- Are highly reliable - controlled disconnection, arc-quenching
- Are safer - controlled behaviour even when surge ratings are exceeded
- Have longer life - protection against ageing
- Have up to 20 years warranty

SAFETEC B(R) TCG Series:
SAFETEC B(R) 12.5/xxx TCG
SAFETUBE B 50

SAFEBLOC B(R) TCG Series:
SAFEBLOC B(R) 25/xxx (2+0) TCG
SAFEBLOC B(R) 37.5/xxx (3+0) TCG
SAFEBLOC B(R) 50/xxx (4+0) TCG
SAFEBLOC B(R) 25/xxx (1+1) TCG
SAFEBLOC B(R) 50/xxx (3+1) TCG

The SAFETEC B(R) TCG and SAFEBLOC B(R) TCG series of overvoltage surge protective devices have been developed to protect against partial direct and indirect lightning discharges and are intended to provide protection in zones 0_A - 2 per IEC 62305.

All in one protection from overvoltages, surges and transients in accordance to IEC/EN 61643-11.

SAFETEC B(R) TCG and SAFEBLOC B(R) TCG series consists of separate, high performance varistors and **TCG circuit**, each with a separate disconnection device.

The compact SAFETEC B(R) TCG and SAFEBLOC B(R) TCG series is suitable for all types of connection. Patented TCG technology prevents catastrophic failures in the case of TOV (temporary overvoltage).

*TCG - Thermal control function without leakage current



SAFETEC B(R) TCG



- Category IEC / EN / VDE: Class I, II / Type 1, 2 / B, C
- Location of use: Main distribution boards
- Network systems: TN-S, TN-C, IT, TT
- Protection modes: L/N - PE, L- PEN
- Protective elements: High energy MOV and GDT
- Surge discharge rating: $I_{imp} = 12.5kA$
- Safety: TOV immunity
- Leakage current: NO leakage current (TCG)
- Housing: Compact design
- Complies with: IEC/EN 61643-11, UL 1449 3rd Ed.



Technical data

Type	SAFETEC B(R) 12.5/xxx TCG			
	150	275	440	
Electrical characteristics				
Max. continuous operating voltage (AC/DC)	U_C	150/200V	275/350V	440/580V
Nominal discharge current (8/20)	I_n		12.5kA	
Max. discharge current (8/20)	I_{max}		50kA	
Impulse current (10/350)	I_{imp}		12.5kA	
Specific energy	W/R		39kJ/Ω	
Charge	Q		6.25As	
Protection level	U_p	< 0.65kV	< 1.1kV	< 1.6kV
Residual voltage at 5kA (8/20)	U_{res}	< 0.55kV	< 0.8kV	< 1.4kV
Follow current	I_{fi}		NO	
Response time	t_A		< 25ns	
Thermal protection			YES	
Back-up fuse (if mains > 250A)			250A gL	
TOV immunity (withstand for unlimited time up to)	U_T	300V	700V	900V
Mechanical characteristics				
Terminal screw torque			max. 3.0Nm	
Temperature range			- 40°C + 80°C	
Terminal cross section			35mm ² (solid) / 25mm ² (stranded)	
Mounting			35mm DIN rail, EN 60715	
Degree of protection			IP 20	
Housing material			thermoplastic; extinguishing degree UL 94 V-0	
Indication of disconnector operation			red flag	
Remote contacts (RC)			YES	
Contact ratings			AC: 250V/0.5A; 125V/3A	
Terminal cross section			max. 1.5mm ²	
Remote terminal torque			0.25Nm	

Ordering information

U_C	150	275	440
Ordering code SAFETEC B 12.5/xxx TCG	54.0146	54.0148	54.0150
Ordering code SAFETEC BR 12.5/xxx TCG (with remote contacts)	54.0147	54.0149	54.0151

TC solution available on request



SAFETUBE B 50



- Category IEC / EN / VDE: Class I, II / Type 1, 2 / B, C
- Location of use: Main distribution boards
- Network system: TT
- Protection modes: N - PE
- Protective element: High energy GDT
- Surge discharge rating: $I_{imp} = 50kA$
- Housing: Compact design
- Complies with: IEC/EN 61643-11, UL 1449 3rd Ed.



Technical data

Type		SAFETUBE B 50
Electrical characteristics		
Max. continuous operating voltage (AC/DC)	U_C	255V
Nominal discharge current (8/20)	I_n	50kA
Max. discharge current (8/20)	I_{max}	100kA
Impulse current (10/350)	I_{imp}	50kA
Specific energy	W/R	625kJ/Ω
Charge	Q	25As
Protection level	U_p	< 1.5kV
Follow current	I_{fi}	100A _{RMS}
Response time	t_A	< 100ns
Mechanical characteristics		
Temperature range		- 40°C+ 80°C
Terminal screw torque		max. 3.0Nm
Terminal cross section		35mm ² (solid)/25mm ² (stranded)
Mounting		35mm DIN rail, EN 60715
Degree of protection		IP 20
Housing material		thermoplastic; extinguishing degree UL 94 V-0
Remote contacts (RC)		YES
Contact ratings		AC: 250V/0.5A; 125V/3A
Terminal cross section		max. 1.5mm ²
Remote terminal torque		0.25Nm

Ordering information

I_{imp}	50
Ordering code SAFETUBE B 50	54.0006



Dimensions, Internal configuration, Weight and Packaging

SAFETEC B(R) 12.5/xxx TCG

Dimensions

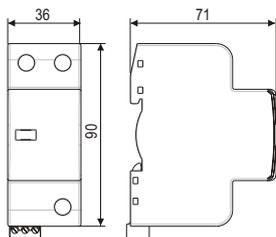

Internal configuration

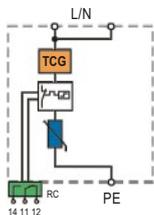

SAFETEC B 12.5/xxx TCG	150	275	440
Dimensions DIN 43880		2TE	
Weight per unit	175g	205g	255g
SAFETEC BR 12.5/xxx TCG	150	275	440
Dimensions DIN 43880		2TE	
Weight per unit	180g	210g	260g
Packaging dimensions (single unit)	109 x 76.5 x 41.5mm		
Min. packaging quantity	7 pcs.		

SAFETUBE B 50

Dimensions

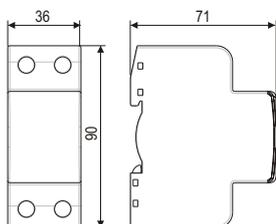

Internal configuration

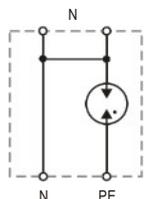

SAFETUBE B 50			
Dimensions DIN 43880		2TE	
Weight per unit		180g	
Packaging dimensions (single unit)	108 x 76.5 x 41.5mm		
Min. packaging quantity	7 pcs.		



SAFEBLOC B(R) TCG Series



- Category IEC / EN / VDE: Class I, II / Type 1, 2 / B, C
- Location of use: Main distribution boards
- Network systems: TN-S, TN-C, IT
- Protection modes: L/N - PE, L- PEN
- Protective elements: High energy MOV and GDT
- Surge discharge rating: $I_{imp} = 12.5kA$
- Safety: TOV immunity
- Leakage current: NO leakage current (TCG)
- Housing: Compact design
- Complies with: IEC/EN 61643-11, UL 1449 3rd Ed.



Technical data

Type		SAFEBLOC B(R) yy/xxx (2+0)	(3+0)	(4+0) TCG
		150	275	440
Electrical characteristics				
Max. continuous operating voltage (AC/DC)	U_C	150/200V	275/350V	440/580V
Nominal discharge current (8/20)	I_n		12.5kA/pole	
Max. discharge current (8/20)	I_{max}		50kA/pole	
Impulse current (10/350)	I_{imp}		12.5kA/pole	
Specific energy	W/R		6.25kJ/Ω	
Charge	Q		12.5As	
Protection level	U_p	< 0.65kV	< 1.1kV	< 1.6kV
Residual voltage at 5kA (8/20)	U_{res}	< 0.55kV	< 0.8kV	< 1.4kV
Follow current	I_{fi}		NO	
Response time	t_A		< 25ns	
Thermal protection			YES	
Back-up fuse (if mains > 250A)			250A gL	
TOV immunity (withstand for unlimited time up to)	U_T	300V	700V	900V
Mechanical characteristics				
Terminal screw torque			max. 3.0Nm	
Temperature range			- 40°C + 80°C	
Terminal cross section			35mm ² (solid) / 25mm ² (stranded)	
Mounting			35mm DIN rail, EN 60715	
Degree of protection			IP 20	
Housing material			thermoplastic; extinguishing degree UL 94 V-0	
Indication of disconnector operation			red flag	
Remote contacts (RC)			YES	
Contact ratings			AC: 250V/0.5A; 125V/3A	
Terminal cross section			max. 1.5mm ²	
Remote terminal torque			0.25Nm	

Ordering information

U_C	150	275	440
Ordering code SAFEBLOC B 25/xxx (2+0) TCG	54.0152	54.0154	54.0156
Ordering code SAFEBLOC BR 25/xxx (2+0) TCG (with remote contacts)	54.0153	54.0155	54.0157
Ordering code SAFEBLOC B 37.5/xxx (3+0) TCG	54.0164	54.0166	54.0168
Ordering code SAFEBLOC BR 37.5/xxx (3+0) TCG (with remote contacts)	54.0165	54.0167	54.0169
Ordering code SAFEBLOC B 50/xxx (4+0) TCG	54.0170	54.0172	54.0174
Ordering code SAFEBLOC BR 50/xxx (4+0) TCG (with remote contacts)	54.0171	54.0173	54.0175

TC solution available on request



Dimensions, Internal configuration, Weight and Packaging

SAFEBLOC B(R) 25/xxx (2+0) TCG

Dimensions

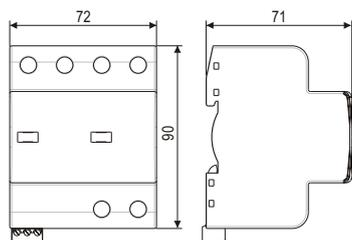

Internal configuration

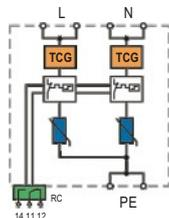

SAFEBLOC B 25/xxx (2+0) TCG	150	275	440
Dimensions DIN 43880		4TE	
Weight per unit	320g	420g	540g
SAFEBLOC BR 25/xxx (2+0) TCG	150	275	440
Dimensions DIN 43880		4TE	
Weight per unit	330g	430g	550g
Packaging dimensions (single unit)	109 x 76.5 x 78mm		
Min. packaging quantity	3 pcs.		

SAFEBLOC B(R) 37.5/xxx (3+0) TCG

Dimensions

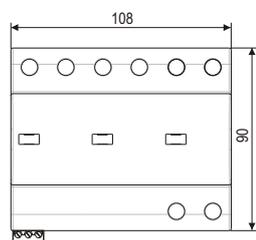

Internal configuration

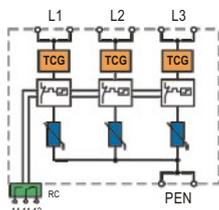

SAFEBLOC B 37.5/xxx (3+0) TCG	150	275	440
Dimensions DIN 43880		6TE	
Weight per unit	430g	530g	740g
SAFEBLOC BR 37.5/xxx (3+0) TCG	150	275	440
Dimensions DIN 43880		6TE	
Weight per unit	435g	535g	745g
Packaging dimensions (single unit)	109 x 76.5 x 148mm		
Min. packaging quantity	2 pcs.		

SAFEBLOC B(R) 50/xxx (4+0) TCG

Dimensions

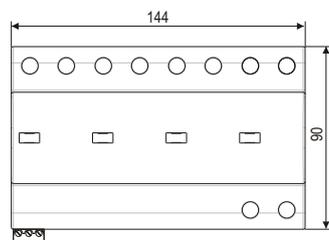

Internal configuration

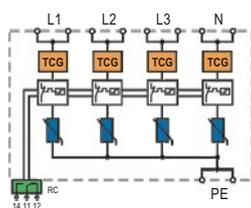

SAFEBLOC B 50/xxx (4+0) TCG	150	275	440
Dimensions DIN 43880		8TE	
Weight per unit	800g	1000g	1160g
SAFEBLOC BR 50/xxx (4+0) TCG	150	275	440
Dimensions DIN 43880		8TE	
Weight per unit	820g	1020g	1180g
Packaging dimensions (single unit)	109 x 76.5 x 148mm		
Min. packaging quantity	2 pcs.		



SAFEBLOC B(R) TCG Series



- **Category IEC / EN / VDE:** Class I, II / Type 1, 2 / B, C
- **Location of use:** Main distribution boards
- **Network system:** TT, TN-S
- **Protection modes:** L-N, N-PE
- **Protective elements:** High energy MOV and GDT
- **Surge discharge rating:** $I_{imp} (L-N/N-PE) = 12.5kA/50kA$
- **Safety:** TOV immunity
- **Leakage current:** NO leakage current (TCG)
- **Housing:** Compact design
- **Complies with:** IEC/EN 61643-11, UL 1449 3rd Ed.



Technical data

Type		SAFEBLOC B(R) yy/xxx (1+1)	(3+1) TCG	
		150	275	440
Electrical characteristics				
Max. continuous operating voltage (AC/DC)	U_c (L-N)	150/200V	275/350V	440/580V
	U_c (N-PE)		255V	
Nominal discharge current (8/20)	I_n (L-N/N-PE)		12.5kA/50kA	
Max. discharge current (8/20)	I_{max} (L-N/N-PE)		50kA/100kA	
Impulse current (10/350)	I_{imp} (L-N/N-PE)		12.5kA/50kA	
Specific energy	W/R (L-N/N-PE)		39kJ/Ω/625kJ/Ω	
Charge	Q (L-N/N-PE)		6.25As/25As	
Protection level	U_p (L-N)	< 0.65kV	< 1.1kV	< 1.6kV
	U_p (N-PE)		< 1.5kV	
Residual voltage at 5kA (8/20)	U_{res} (L-N)	< 0.55kV	< 0.8kV	< 1.4kV
Follow current	I_{ff} (L-N/N-PE)		100A _{RMS}	
Response time	t_A (L-N/N-PE)		< 25ns/100ns	
Thermal protection	(L-N/N-PE)		YES/-	
Back-up fuse (if mains > 250A)	(L-N)		250A gL	
TOV immunity (withstand for unlimited time up to)	U_T	300V	700V	900V
Mechanical characteristics				
Terminal screw torque			max. 3.0Nm	
Temperature range			-40°C +80°C	
Terminal cross section			35mm ² (solid) / 25mm ² (stranded)	
Mounting			35mm DIN rail, EN 60715	
Degree of protection			IP 20	
Housing material			thermoplastic; extinguishing degree UL 94 V-0	
Indication of disconnector operation			red flag	
Remote contacts (RC)			YES	
Contact ratings			AC: 250V/0.5A; 125V/3A	
Terminal cross section			max. 1.5mm ²	
Remote terminal torque			0.25Nm	

Ordering information

U_c	150	275	440
Ordering code SAFEBLOC B 25/xxx (1+1) TCG	54.0158	54.0160	54.0162
Ordering code SAFEBLOC BR 25/xxx (1+1) TCG (with remote contacts)	54.0159	54.0161	54.0163
Ordering code SAFEBLOC B 50/xxx (3+1) TCG	54.0176	54.0178	54.0180
Ordering code SAFEBLOC BR 50/xxx (3+1) TCG (with remote contacts)	54.0177	54.0179	54.0181

TC solution available on request



Dimensions, Internal configuration, Weight and Packaging

SAFEBLOC B(R) 25/xxx (1+1) TCG

Dimensions

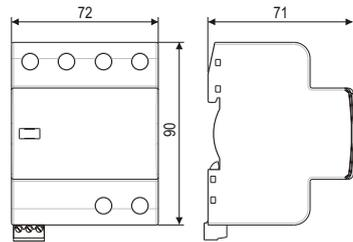

Internal configuration

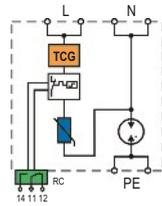

SAFEBLOC B 25/xxx (1+1) TCG	150	275	440
Dimensions DIN 43880		4TE	
Weight per unit	280g	315g	340g
SAFEBLOC BR 25/xxx (1+1) TCG	150	275	440
Dimensions DIN 43880		4TE	
Weight per unit	285g	320g	345g
Packaging dimensions (single unit)	109 x 76.5 x 78mm		
Min. packaging quantity	3 pcs.		

SAFEBLOC B(R) 50/xxx (3+1) TCG

Dimensions

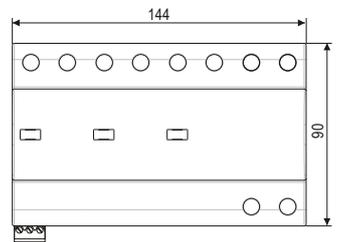

Internal configuration

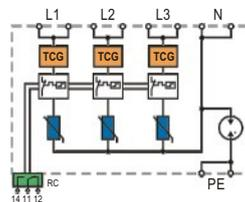

SAFEBLOC B 50/xxx (3+1) TCG	150	275	440
Dimensions DIN 43880		8TE	
Weight per unit	785g	900g	1020g
SAFEBLOC BR 50/xxx (3+1) TCG	150	275	440
Dimensions DIN 43880		8TE	
Weight per unit	800g	915g	1035g
Packaging dimensions (single unit)	109 x 76.5 x 148mm		
Min. packaging quantity	2 pcs.		



SAFETEC B(R) TCG and SAFETUBE B

Network connections

TN-S Network - Single-phase (T-connection)

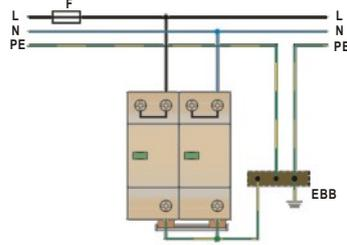

TN-S Network - Single-phase (V-connection)

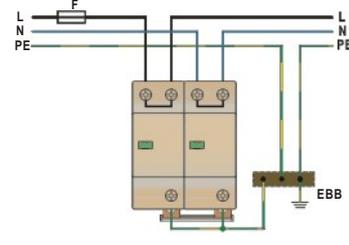

TN-C Network - Three-phase (T-connection)

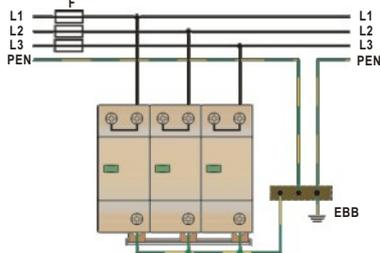

TN-C Network - Three-phase (V-connection)

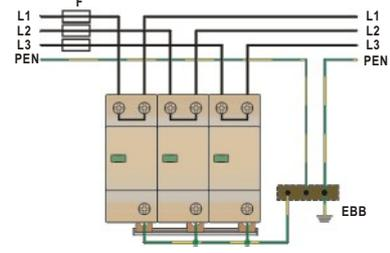

TN-S Network - Three-phase (T-connection)

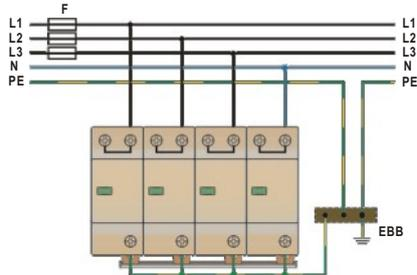

TN-S Network - Three-phase (V-connection)

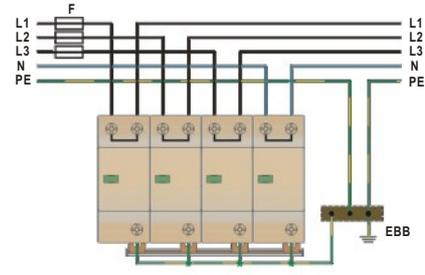

TT Network - Single-phase (T-connection)

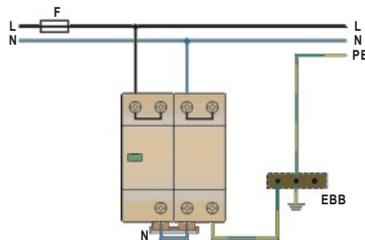

TT Network - Single-phase (V-connection)

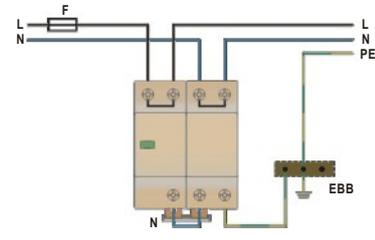

TT Network - Three-phase (T-connection)

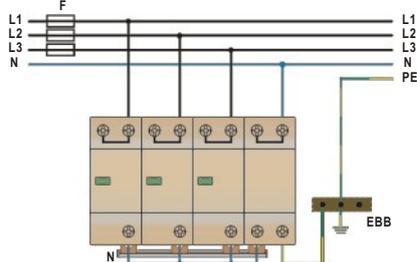

TT Network - Three-phase (V-connection)

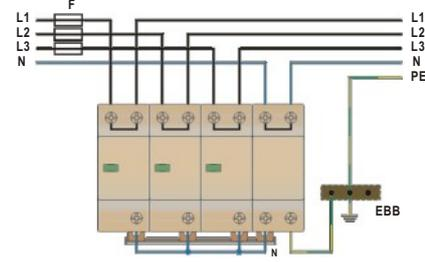

IT Network - Three-phase (T-connection)

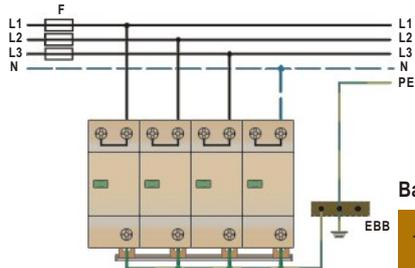

IT Network - Three-phase (V-connection)

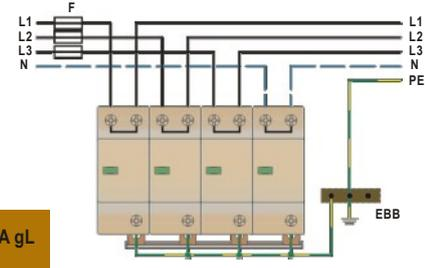

$$U_c \geq 1.1 \cdot U_n \cdot \sqrt{3}$$

Back-up fuse

- $F1 > 250 \text{ A gL}$ → $F2 = 250 \text{ A gL}$
- $F1 \leq 250 \text{ A gL}$ → $F2$



SAFEBLOC B(R) TCG Series

Network connections

TN-S Network - Single-phase (T-connection)

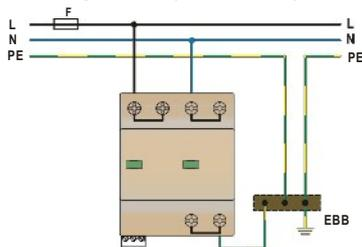

TN-S Network - Single-phase (V-connection)

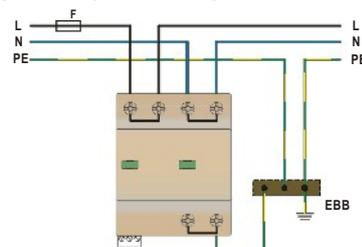

TN-C Network - Three-phase (T-connection)

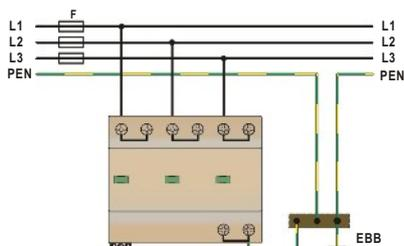

TN-C Network - Three-phase (V-connection)

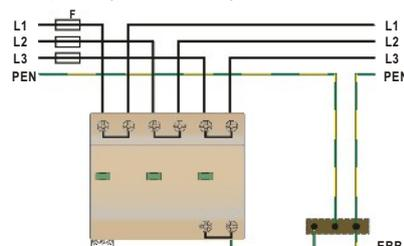

TN-S Network - Three-phase (T-connection)

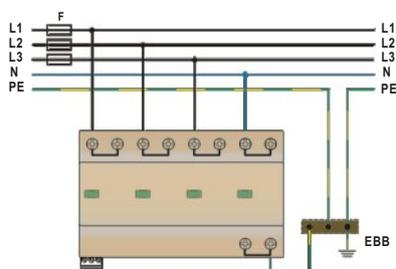

TN-S Network - Three-phase (V-connection)

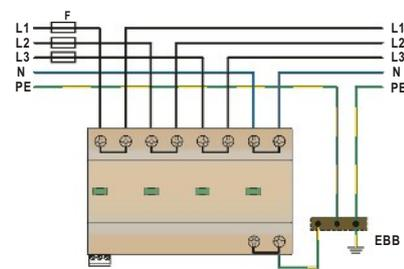

TT Network - Single-phase (T-connection)

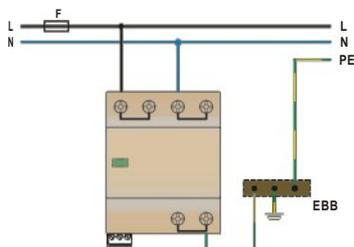

TT Network - Single-phase (V-connection)

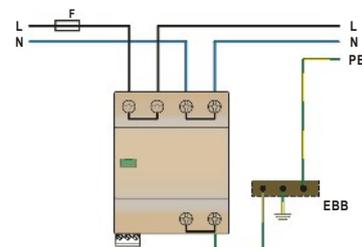

TT Network - Three-phase (T-connection)

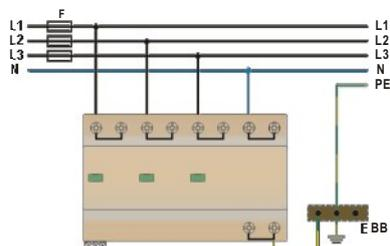

TT Network - Three-phase (V-connection)

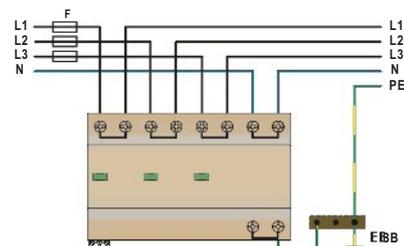

IT Network - Three-phase (T-connection)

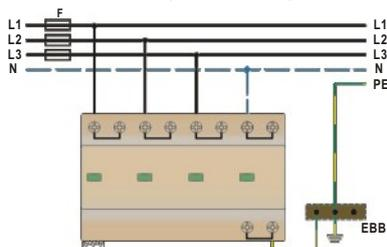

IT Network - Three-phase (V-connection)

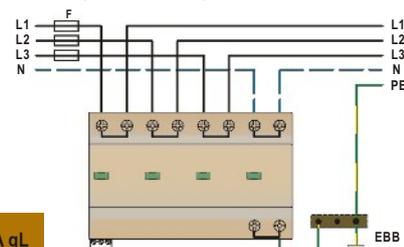

$$U_c \geq 1.1 \cdot U_n \cdot \sqrt{3}$$

Back-up fuse



Class I, II Compact Single and Multi-pole SPD 25kA per pole



Category IEC / EN / VDE:	Class I, II / Type 1, 2 / B, C
Location of use:	Main distribution boards
Protection modes:	L/N-PE, L-PEN, L-N, N-PE
Protective elements:	High energy MOV and GDT
Surge discharge rating:	$I_{imp} = 25kA$
Safety:	TOV immunity
Internal protection:	Separate thermal disconnecter for each MOV
Complies with:	IEC/EN 61643-11, UL 1449 3rd Ed.

The new SAFETEC B(R) TCG* and SAFEBLOC B(R) TCG* series of SPDs :

- Have no impact on the network in normal operation due to no leakage current design
- Are highly reliable - controlled disconnection, arc-quenching
- Are safer - controlled behaviour even when surge ratings are exceeded
- Have longer life - protection against ageing
- Have up to 20 years warranty

SAFETEC B(R) TCG Series:
SAFETEC B(R) 25/xxx TCG
SAFETUBE B 50, 100

SAFEBLOC B(R) TCG Series:
SAFEBLOC B(R) 50/xxx (2+0) TCG
SAFEBLOC B(R) 75/xxx (3+0) TCG
SAFEBLOC B(R) 100/xxx (4+0) TCG
SAFEBLOC B(R) 50/xxx (1+1) TCG
SAFEBLOC B(R) 100/xxx (3+1) TCG

The SAFETEC B(R) TCG and SAFEBLOC B(R) TCG series of overvoltage surge protective devices have been developed to protect against partial direct and indirect lightning discharges and are intended to provide protection in zones 0_A - 2 per IEC 62305.

All in one protection from overvoltages, surges and transients in accordance to IEC/EN 61643-11.

SAFETEC B(R) TCG and SAFEBLOC B(R) TCG series consists of separate, high performance varistors and **TCG circuit**, each with a separate disconnection device.

The compact SAFETEC B(R) TCG and SAFEBLOC B(R) TCG series is suitable for all types of connection. Patented TCG technology prevents catastrophic failures in the case of TOV (temporary overvoltage).

*TCG - Thermal control function without leakage current



SAFETEC B(R) TCG



- **Category IEC / EN / VDE:** Class I, II / Type 1, 2 / B, C
- **Location of use:** Main distribution boards
- **Network systems:** TN-S, TN-C, IT, TT
- **Protection modes:** L/N - PE, L- PEN
- **Protective elements:** High energy MOV and GDT
- **Surge discharge rating:** $I_{imp} = 25kA$
- **Safety:** TOV immunity
- **Leakage current:** NO leakage current (TCG)
- **Housing:** Compact design
- **Complies with:** IEC/EN 61643-11, UL 1449 3rd Ed.



Technical data

Type	SAFETEC B(R) 25/xxx TCG			
	150	275	440	
Electrical characteristics				
Max. continuous operating voltage (AC/DC)	U_C	150/200V	275/350V	440/580V
Nominal discharge current (8/20)	I_n	25kA		
Max. discharge current (8/20)	I_{max}	100kA		
Impulse current (10/350)	I_{imp}	25kA		
Specific energy	W/R	156kJ/Ω		
Charge	Q	12.5As		
Protection level	U_p	< 0.85kV	< 1.3kV	< 1.9kV
Residual voltage at 5kA (8/20)	U_{res}	< 0.55kV	< 0.8kV	< 1.4kV
Follow current	I_{fi}	NO		
Response time	t_A	< 25ns		
Thermal protection		YES		
Back-up fuse (if mains > 250A)		250A gL		
TOV immunity (withstand for unlimited time up to)	U_T	300V	700V	900V
Mechanical characteristics				
Terminal screw torque		max. 3.0Nm		
Temperature range		- 40°C + 80°C		
Terminal cross section		35mm ² (solid) / 25mm ² (stranded)		
Mounting		35mm DIN rail, EN 60715		
Degree of protection		IP 20		
Housing material		thermoplastic; extinguishing degree UL 94 V-0		
Indication of disconnector operation		red flag		
Remote contacts (RC)		YES		
Contact ratings		AC: 250V/0.5A; 125V/3A		
Terminal cross section		max. 1.5mm ²		
Remote terminal torque		0.25Nm		

Ordering information

U_C	150	275	440
Ordering code SAFETEC B 25/xxx TCG	54.0038	54.0040	54.0042
Ordering code SAFETEC BR 25/xxx TCG (with remote contacts)	54.0039	54.0041	54.0043

TC solution available on request

SAFETUBE B



- **Category IEC / EN / VDE:** Class I, II / Type 1, 2 / B, C
- **Location of use:** Main distribution boards
- **Network system:** TT
- **Protection modes:** N - PE
- **Protective element:** High energy GDT
- **Surge discharge rating:** I_{imp} = up to 100kA
- **Housing:** Compact design
- **Complies with:** IEC/EN 61643-11, UL 1449 3rd Ed.



Technical data

Type	SAFETUBE B yyy	
	50	100
Electrical characteristics		
Max. continuous operating voltage (AC/DC)	U_C	255V
Nominal discharge current (8/20)	I_n	50kA
Max. discharge current (8/20)	I_{max}	100kA
Impulse current (10/350)	I_{imp}	50kA
Specific energy	W/R	625kJ/Ω
Charge	Q	25As
Protection level	U_p	< 1.5kV
Follow current	I_{fi}	100A _{RMS}
Response time	t_A	< 100ns
Mechanical characteristics		
Temperature range		- 40°C + 80°C
Terminal screw torque		max. 3.0Nm
Terminal cross section		35mm ² (solid)/25mm ² (stranded)
Mounting		35mm DIN rail, EN 60715
Degree of protection		IP 20
Housing material		thermoplastic; extinguishing degree UL 94 V-0
Remote contacts RC		YES
Contact ratings		AC: 250V/0.5A; 125V/3A
Terminal cross section		max. 1.5mm ²
Remote terminal torque		0.25Nm

Ordering information

I_{imp}	50	100
Ordering code SAFETUBE B yyy	54.0006	54.0007



Dimensions, Internal configuration, Weight and Packaging

SAFETEC B(R) 25/xxx TCG

Dimensions

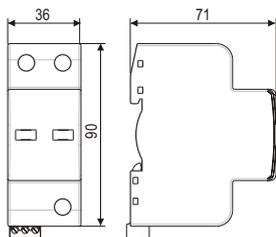

Internal configuration

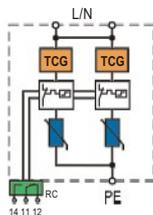

SAFETEC B 25/xxx TCG	150	275	440
Dimensions DIN 43880	2TE		
Weight per unit	275g	325g	375g
SAFETEC BR 25/xxx TCG	150	275	440
Dimensions DIN 43880	2TE		
Weight per unit	280g	330g	380g
Packaging dimensions (single unit)	109 x 76.5 x 41.5mm		
Min. packaging quantity	7 pcs.		

SAFETUBE B yyy

Dimensions

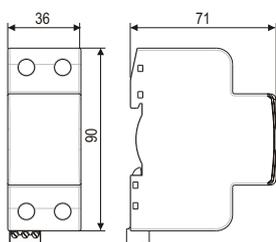

Internal configuration

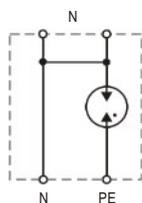

SAFETUBE B yyy	50	100
Dimensions DIN 43880	2TE	
Weight per unit	180g	240g
Packaging dimensions (single unit)	108 x 76.5 x 41.5mm	
Min. packaging quantity	7 pcs.	



SAFEBLOC B(R) TCG Series



- Category IEC / EN / VDE: Class I, II / Type 1, 2 / B, C
- Location of use: Main distribution boards
- Network systems: TN-S, TN-C, IT
- Protection modes: L/N - PE, L- PEN
- Protective elements: High energy MOV and GDT
- Surge discharge rating: $I_{imp} = 25kA$
- Safety: TOV immunity
- Leakage current: NO leakage current (TCG)
- Housing: Compact design
- Complies with: IEC/EN 61643-11, UL 1449 3rd Ed.



Technical data

Type		SAFEBLOC B(R) yy/xxx (2+0)	(3+0)	(4+0) TCG
		150	275	440
Electrical characteristics				
Max. continuous operating voltage (AC/DC)	U_C	150/200V	275/350V	440/580V
Nominal discharge current (8/20)	I_n		25kA/pole	
Max. discharge current (8/20)	I_{max}		100kA/pole	
Impulse current (10/350)	I_{imp}		25kA/pole	
Specific energy	W/R		156kJ/Ω	
Charge	Q		12.5As	
Protection level	U_p	< 0.85kV	< 1.3kV	< 1.9kV
Residual voltage at 5kA (8/20)	U_{res}	< 0.55kV	< 0.8kV	< 1.4kV
Follow current	I_{fi}		NO	
Response time	t_A		< 25ns	
Thermal protection			YES	
Back-up fuse (if mains > 250A)			250A gL	
TOV immunity (withstand for unlimited time up to)	U_T	300V	700V	900V
Mechanical characteristics				
Terminal screw torque			max. 3.0Nm	
Temperature range			- 40°C + 80°C	
Terminal cross section			35mm ² (solid) / 25mm ² (stranded)	
Mounting			35mm DIN rail, EN 60715	
Degree of protection			IP 20	
Housing material			thermoplastic; extinguishing degree UL 94 V-0	
Indication of disconnector operation			red flag	
Remote contacts (RC)			YES	
Contact ratings			AC: 250V/0.5A; 125V/3A	
Terminal cross section			max. 1.5mm ²	
Remote terminal torque			0.25Nm	

Ordering information

U_C	150	275	440
Ordering code SAFEBLOC B 50/xxx (2+0) TCG	54.0044	54.0046	54.0048
Ordering code SAFEBLOC BR 50/xxx (2+0) TCG (with remote contacts)	54.0045	54.0047	54.0049
Ordering code SAFEBLOC B 75/xxx (3+0) TCG	54.0056	54.0058	54.0060
Ordering code SAFEBLOC BR 75/xxx (3+0) TCG (with remote contacts)	54.0057	54.0059	54.0061
Ordering code SAFEBLOC B 100/xxx (4+0) TCG	54.0062	54.0064	54.0066
Ordering code SAFEBLOC BR 100/xxx (4+0) TCG (with remote contacts)	54.0063	54.0065	54.0067

TC solution available on request



Dimensions, Internal configuration, Weight and Packaging

SAFEBLOC B(R) 50/xxx (2+0) TCG

Dimensions

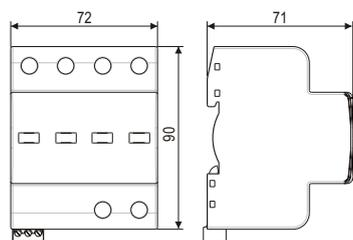

Internal configuration

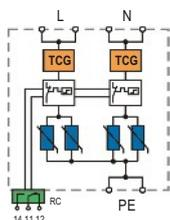

SAFEBLOC B 50/xxx (2+0) TCG	150	275	440
Dimensions DIN 43880		4TE	
Weight per unit	520g	620g	740g
SAFEBLOC BR 50/xxx (2+0) TCG	150	275	440
Dimensions DIN 43880		4TE	
Weight per unit	530g	630g	750g
Packaging dimensions (single unit)	109 x 76.5 x 78mm		
Min. packaging quantity	3 pcs.		

SAFEBLOC B(R) 75/xxx (3+0) TCG

Dimensions

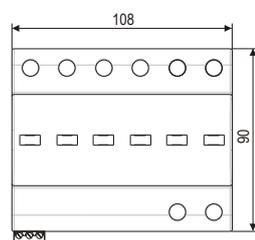

Internal configuration

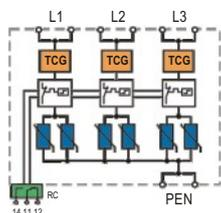

SAFEBLOC B 75/xxx (3+0) TCG	150	275	440
Dimensions DIN 43880		6TE	
Weight per unit	780g	930g	1095g
SAFEBLOC BR 75/xxx (3+0) TCG	150	275	440
Dimensions DIN 43880		6TE	
Weight per unit	795g	945g	1110g
Packaging dimensions (single unit)	109 x 76.5 x 148mm		
Min. packaging quantity	2 pcs.		

SAFEBLOC B(R) 100/xxx (4+0) TCG

Dimensions

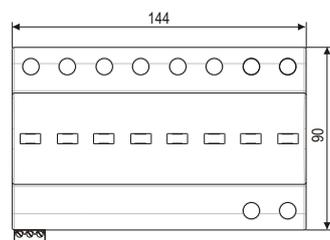

Internal configuration

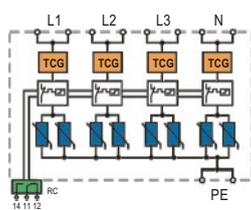

SAFEBLOC B 100/xxx (4+0) TCG	150	275	440
Dimensions DIN 43880		8TE	
Weight per unit	1040g	1240g	1460g
SAFEBLOC BR 100/xxx (4+0) TCG	150	275	440
Dimensions DIN 43880		8TE	
Weight per unit	1060g	1260g	1480g
Packaging dimensions (single unit)	109 x 76.5 x 148mm		
Min. packaging quantity	2 pcs.		



SAFEBLOC B(R) (1+1) TCG



- Category IEC / EN / VDE: Class I, II / Type 1, 2 / B, C
- Location of use: Main distribution boards
- Network system: TT, TN-S
- Protection modes: L-N, N-PE
- Protective elements: High energy MOV and GDT
- Surge discharge rating: I_{imp} (L-N/N-PE) = 25kA/50kA
- Safety: TOV immunity
- Leakage current: NO leakage current (TCG)
- Housing: Compact design
- Complies with: IEC/EN 61643-11, UL 1449 3rd Ed.



Technical data

Type	SAFEBLOC B(R) 50/xxx (1+1) TCG			
	150	275	440	
Electrical characteristics				
Max. continuous operating voltage (AC/DC)	U_c (L-N)	150/200V	275/350V	440/580V
	U_c (N-PE)		255V	
Nominal discharge current (8/20)	I_n (L-N/N-PE)		25kA/50kA	
Max. discharge current (8/20)	I_{max} (L-N/N-PE)		100kA/100kA	
Impulse current (10/350)	I_{imp} (L-N/N-PE)		25kA/50kA	
Specific energy	W/R (L-N/N-PE)		156kJ/Ω/625kJ/Ω	
Charge	Q (L-N/N-PE)		12.5As/25As	
Protection level	U_p (L-N)	< 0.85kV	< 1.3kV	< 1.9kV
	U_p (N-PE)		< 1.5kV	
Residual voltage at 5kA (8/20)	U_{res} (L-N)	< 0.55kV	< 0.8kV	< 1.4kV
Follow current	I_{fj} (L-N/N-PE)		100A _{RMS}	
Response time	t_A (L-N/N-PE)		< 25ns/100ns	
Thermal protection	(L-N/N-PE)		YES/-	
TOV immunity (withstand for unlimited time up to)	U_T	300V	700V	900V
Mechanical characteristics				
Terminal screw torque			max. 3.0Nm	
Temperature range			- 40°C + 80°C	
Terminal cross section			35mm ² (solid) / 25mm ² (stranded)	
Mounting EN 60715			35mm top-hat rail	
Degree of protection			IP 20	
Housing material			thermoplastic; extinguishing degree UL 94 V-0	
Indication of disconnector operation			red flag	
Remote contacts (RC)			YES	
Contact ratings			AC: 250V/0.5A; 125V/3A	
Terminal cross section			max. 1.5mm ²	
Remote terminal torque			0.25Nm	

Ordering information

U_c	150	275	440
Ordering code SAFEBLOC B 50/xxx (1+1) TCG	54.0050	54.0052	54.0054
Ordering code SAFEBLOC BR 50/xxx (1+1) TCG (with remote contacts)	54.0051	54.0053	54.0055

TC solution available on request



SAFEBLOC B(R) (3+1) TCG



- **Category IEC / EN / VDE:** Class I, II / Type 1, 2 / B, C
- **Location of use:** Main distribution boards
- **Network system:** TT, TN-S
- **Protection modes:** L-N, N-PE
- **Protective elements:** High energy MOV and GDT
- **Surge discharge rating:** I_{imp} (L-N/N-PE) = 25kA/100kA
- **Safety:** TOV immunity
- **Leakage current:** NO leakage current (TCG)
- **Housing:** Compact design
- **Complies with:** IEC/EN 61643-11, UL 1449 3rd Ed.



Technical data

Type	SAFEBLOC B(R) 100/xxx (3+1) TCG			
	150	275	440	
Electrical characteristics				
Max. continuous operating voltage (AC/DC)	U_c (L-N)	150/200V	275/350V	440/580V
	U_c (N-PE)		255V	
Nominal discharge current (8/20)	I_n (L-N/N-PE)		25kA/100kA	
Max. discharge current (8/20)	I_{max} (L-N/N-PE)		100kA/100kA	
Impulse current (10/350)	I_{imp} (L-N/N-PE)		25kA/100kA	
Specific energy	W/R (L-N/N-PE)		156kJ/Ω/2.5MJ/Ω	
Charge	Q (L-N/N-PE)		12.5As/50As	
Protection level	U_p (L-N)	< 0.85kV	< 1.3kV	< 1.9kV
	U_p (N-PE)		< 1.6kV	
Residual voltage at 5kA (8/20)	U_{res} (L-N)	< 0.55kV	< 0.8kV	< 1.4kV
Follow current	I_{fj} (L-N/N-PE)		100A _{RMS}	
Response time	t_A (L-N/N-PE)		< 25ns/100ns	
Thermal protection	(L-N/N-PE)		YES/-	
Back-up fuse (if mains > 250A)	(L-N)		250A gL	
TOV immunity (withstand for unlimited time up to)	U_T			
Mechanical characteristics				
Terminal screw torque		max. 3.0Nm		
Temperature range		- 40°C + 80°C		
Terminal cross section		35mm ² (solid) / 25mm ² (stranded)		
Mounting		35mm DIN rail, EN 60715		
Degree of protection		IP 20		
Housing material		thermoplastic; extinguishing degree UL 94 V-0		
Indication of disconnector operation		red flag		
Remote contacts (RC)		YES		
Contact ratings		AC: 250V/0.5A; 125V/3A		
Terminal cross section		max. 1.5mm ²		
Remote terminal torque		0.25Nm		

Ordering information

U_c	150	275	440
Ordering code SAFEBLOC B 100/xxx (3+1) TCG	54.0068	54.0070	54.0072
Ordering code SAFEBLOC BR 100/xxx (3+1) TCG (with remote contacts)	54.0069	54.0071	54.0073

TC solution available on request



Dimensions, Internal configuration, Weight and Packaging

SAFEBLOC B(R) 50/xxx (1+1) TCG

Dimensions

Internal configuration

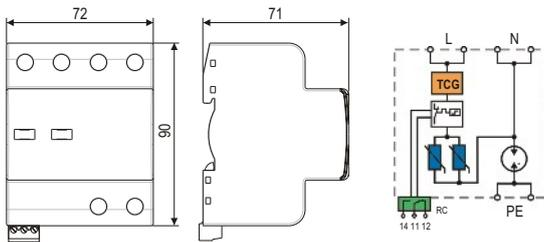

SAFEBLOC B 50/xxx (1+1) TCG	150	275	440
Dimensions DIN 43880	4TE		
Weight per unit	475g	515g	565g
SAFEBLOC BR 50/xxx (1+1) TCG	150	275	440
Dimensions DIN 43880	4TE		
Weight per unit	480g	520g	570g
Packaging dimensions (single unit)	109 x 76.5 x 78mm		
Min. packaging quantity	3 pcs.		

SAFEBLOC B(R) 100/xxx (3+1) TCG

Dimensions

Internal configuration

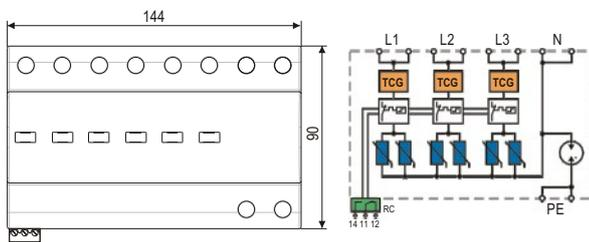

SAFEBLOC B 100/xxx (3+1) TCG	150	275	440
Dimensions DIN 43880	8TE		
Weight per unit	985g	1135g	1285g
SAFEBLOC BR 100/xxx (3+1) TCG	150	275	440
Dimensions DIN 43880	8TE		
Weight per unit	1000g	1150g	1300g
Packaging dimensions (single unit)	109 x 76.5 x 148mm		
Min. packaging quantity	2 pcs.		



SAFETEC B(R) TCG and SAFETUBE B

Network connections

TN-S Network - Single-phase (T-connection)

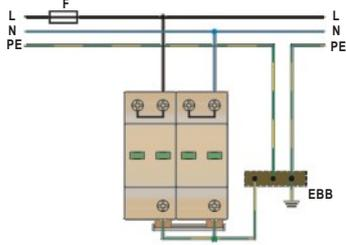

TN-S Network - Single-phase (V-connection)

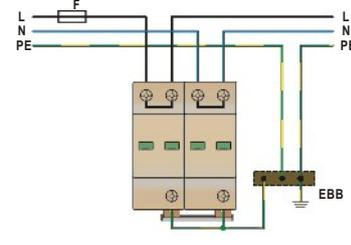

TN-C Network - Three-phase (T-connection)

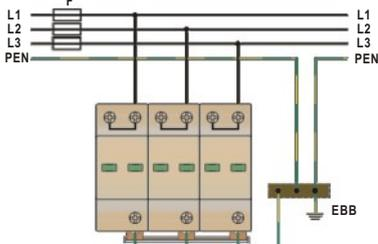

TN-C Network - Three-phase (V-connection)

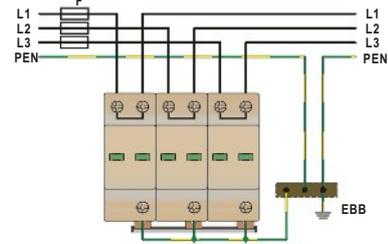

TN-S Network - Three-phase (T-connection)

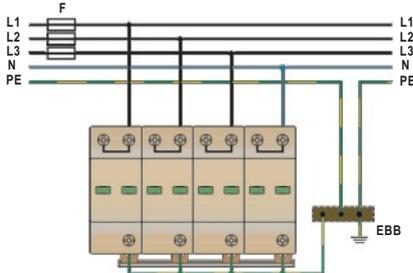

TN-S Network - Three-phase (V-connection)

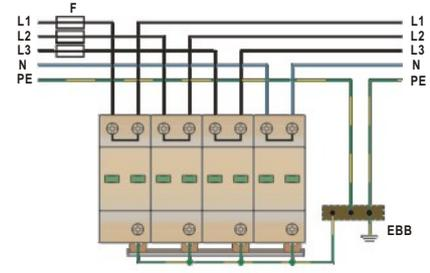

TT Network - Single-phase (T-connection)

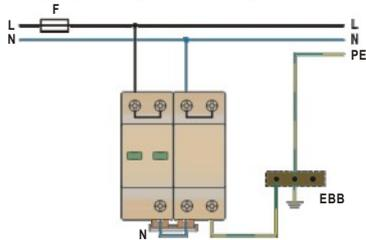

TT Network - Single-phase (V-connection)

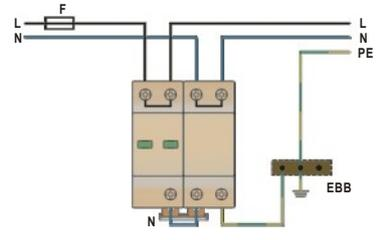

TT Network - Three-phase (T-connection)

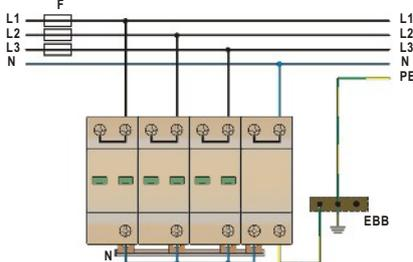

TT Network - Three-phase (V-connection)

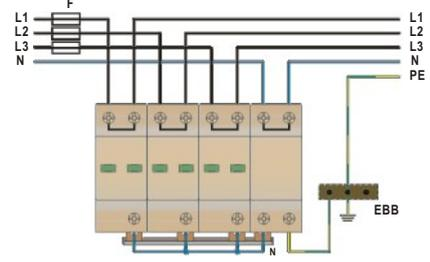

IT Network - Three-phase (T-connection)

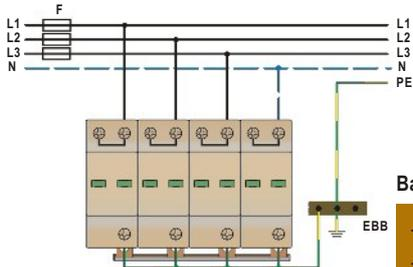

IT Network - Three-phase (V-connection)

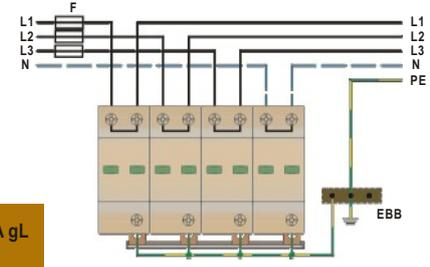

$$U_c \geq 1.1 \cdot U_n \cdot \sqrt{3}$$

Back-up fuse

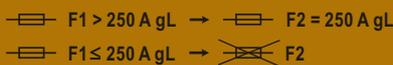



SAFEBLOC B(R) TCG Series

Network connections

TN-S Network - Single-phase (T-connection)

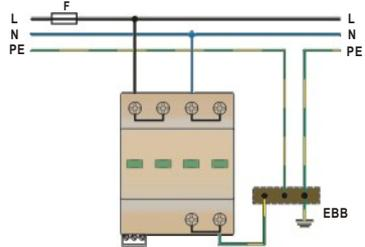

TN-S Network - Single-phase (V-connection)

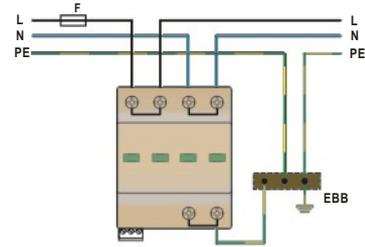

TN-C Network - Three-phase (T-connection)

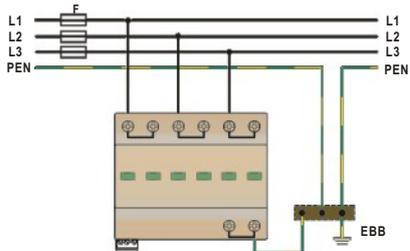

TN-C Network - Three-phase (V-connection)

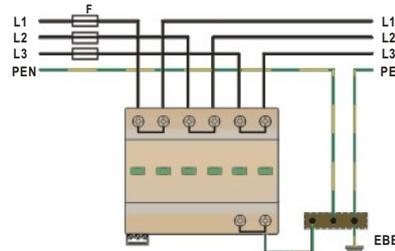

TN-S Network - Three-phase (T-connection)

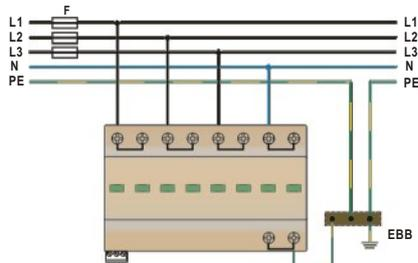

TN-S Network - Three-phase (V-connection)

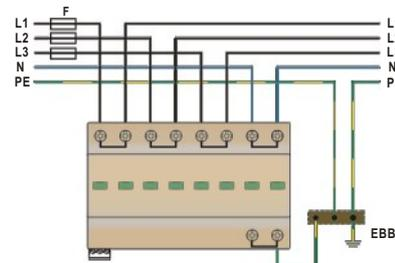

TT Network - Single-phase (T-connection)

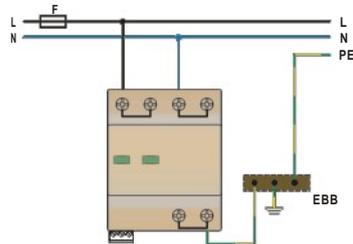

TT Network - Single-phase (V-connection)

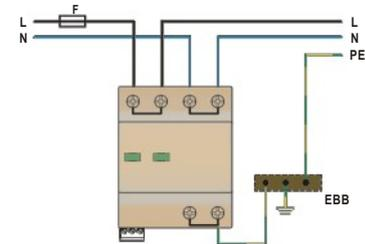

TT Network - Three-phase (T-connection)

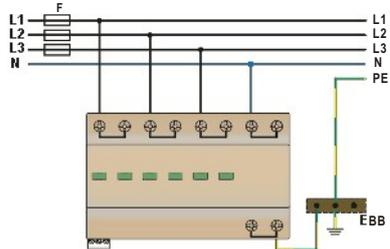

TT Network - Three-phase (V-connection)

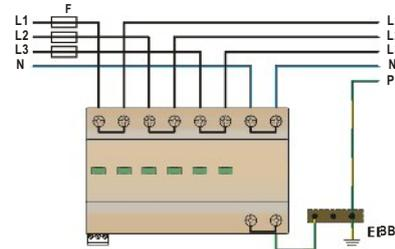

IT Network - Three-phase (T-connection)

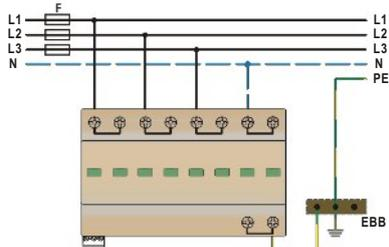

IT Network - Three-phase (V-connection)

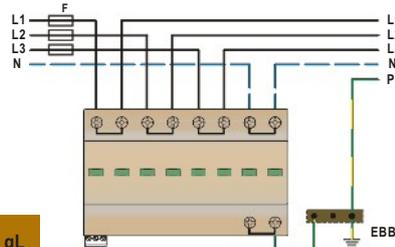

$$U_c \geq 1.1 \cdot U_n \cdot \sqrt{3}$$

Back-up fuse

- F1 > 250 A gL → F2 = 250 A gL
- F1 ≤ 250 A gL → F2

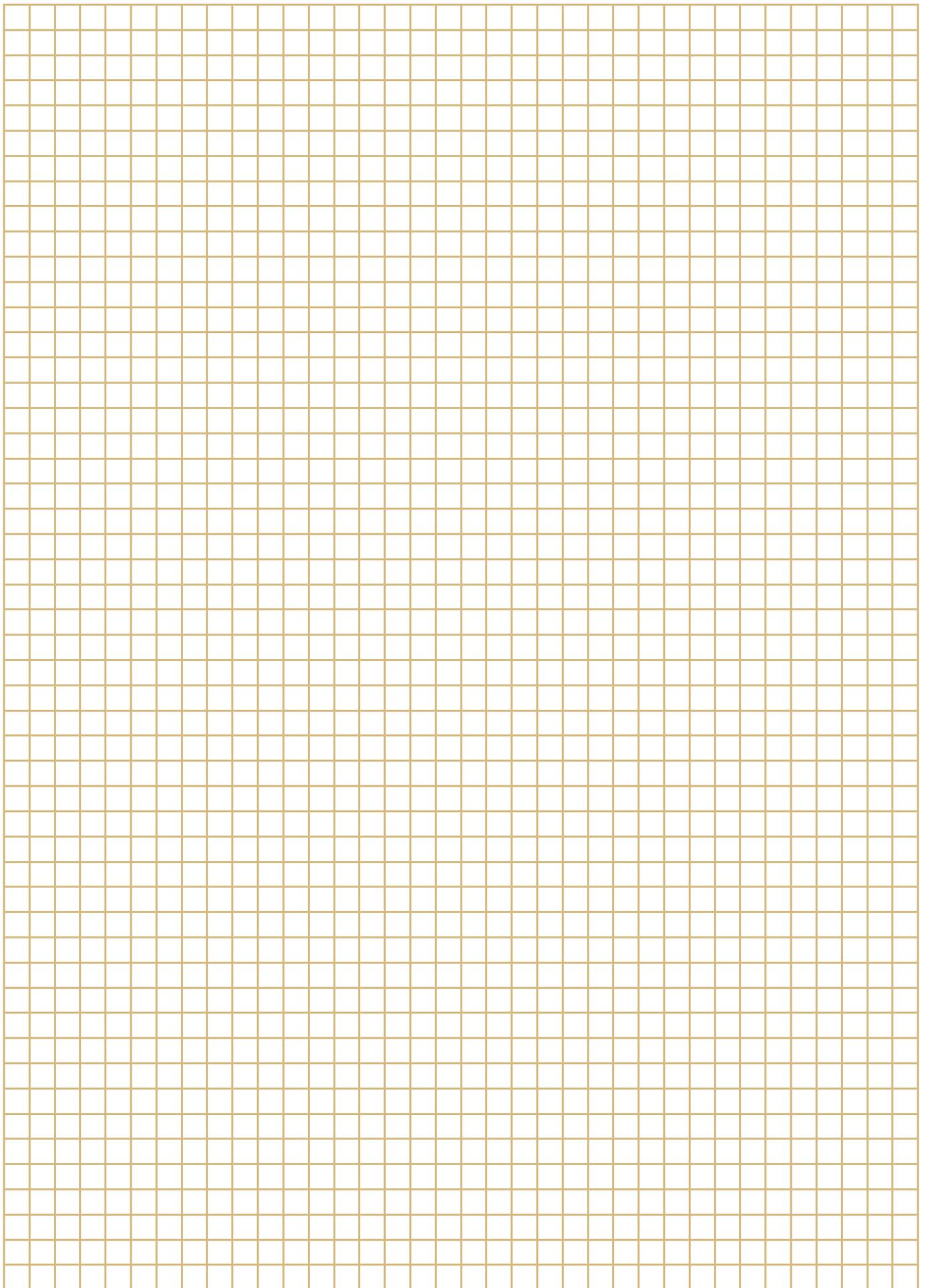

Class I, II Compact Single-pole SPD 35kA and 50kA



Category IEC / EN / VDE:	Class I, II / Type 1, 2 / B, C
Location of use:	Main distribution boards
Protection modes:	L/N-PE, L-PEN
Protective elements:	High energy MOV and GDT
Surge discharge ratings:	$I_{imp} = 35kA$ and $50kA$
Safety:	TOV immunity
Internal protection:	Separate thermal disconnecter for each MOV
Complies with:	IEC/EN 61643-11, UL 1449 3rd Ed.

The new SAFETEC B(R) TCG* and SAFEBLOC B(R) TCG* series of SPDs :

- Have no impact on the network in normal operation due to no leakage current design
- Are highly reliable - controlled disconnection, arc-quenching
- Are safer - controlled behaviour even when surge ratings are exceeded
- Have longer life - protection against ageing
- Have up to 20 years warranty

SAFETEC B(R) 35/xxx TCG SAFETEC B(R) 50/xxx TCG

The SAFETEC B(R) TCG series of overvoltage surge protective devices have been developed to protect against partial direct and indirect lightning discharges and are intended to provide protection in zones 0_A - 2 per IEC 62305.

All in one protection from overvoltages, surges and transients in accordance to IEC/EN 61643-11.

SAFETEC B(R) TCG series consists of separate, high performance varistors and **TCG circuit**, each with a separate disconnection device.

The compact SAFETEC B(R) TCG series is suitable for all types of connection. Patented TCG technology prevents catastrophic failures in the case of TOV (temporary overvoltage).

*TCG - Thermal control function without leakage current



SAFETEC B(R) TCG



- **Category IEC / EN / VDE:** Class I, II / Type 1, 2 / B, C
- **Location of use:** Main distribution boards
- **Network systems:** TN-S, TN-C, IT, TT
- **Protection modes:** L/N - PE, L- PEN
- **Protective element:** High energy MOV
- **Surge discharge rating:** $I_{imp} = 35kA$
- **Safety:** TOV immunity
- **Leakage current:** NO leakage current
- **Housing:** Compact design
- **Complies with:** IEC/EN 61643-11, UL 1449 3rd Ed.



Technical data

Type	SAFETEC B(R) 35/xxx TCG			
	150	275	440	
Electrical characteristics				
Max. continuous operating voltage (AC/DC)	U_C	150/200V	275/350V	440/580V
Nominal discharge current (8/20)	I_n	25kA		
Max. discharge current (8/20)	I_{max}	100kA		
Impulse current (10/350)	I_{imp}	35kA		
Specific energy	W/R	306kJ/Ω		
Charge	Q	17.5As		
Protection level	U_p	< 0.6kV	< 1.2kV	< 1.9kV
Residual voltage at 5kA (8/20)	U_{res}	< 0.5kV	< 0.9kV	< 1.6kV
Follow current	I_{fi}	NO		
Response time	t_A	< 25ns		
Thermal protection		YES		
Back-up fuse (if mains > 350A)		350A gL		
TOV immunity (withstand for unlimited time up to)	U_T	300V	700V	900V
Mechanical characteristics				
Terminal screw torque		max. 3.0Nm		
Temperature range		- 40°C + 80°C		
Terminal cross section		35mm ² (solid) / 25mm ² (stranded)		
Mounting		35mm DIN rail, EN 60715		
Degree of protection		IP 20		
Housing material		thermoplastic; extinguishing degree UL 94 V-0		
Indication of disconnector operation		red flag		
Remote contacts (RC)		YES		
Contact ratings		AC: 250V/0.5A; 125V/3A		
Terminal cross section		max. 1.5mm ²		
Remote terminal torque		0.25Nm		

Ordering information

U_C	150	275	440
Ordering code SAFETEC B 35/xxx TCG	54.0300	54.0302	54.0304
Ordering code SAFETEC BR 35/xxx TCG (with remote contacts)	54.0301	54.0303	54.0305

TC solution available on request



SAFETEC B(R) TCG



- **Category IEC / EN / VDE:** Class I, II / Type 1, 2 / B, C
- **Location of use:** Main distribution boards
- **Network systems:** TN-S, TN-C, IT, TT
- **Protection modes:** L/N - PE, L- PEN
- **Protective element:** High energy MOV
- **Surge discharge rating:** $I_{imp} = 50kA$
- **Safety:** TOV immunity
- **Leakage current:** NO leakage current
- **Housing:** Compact design
- **Complies with:** IEC/EN 61643-11, UL 1449 3rd Ed.



Technical data

Type	SAFETEC B(R) 50/xxx TCG			
	150	275	440	
Electrical characteristics				
Max. continuous operating voltage (AC/DC)	U_C	150/200V	275/350V	440/580V
Nominal discharge current (8/20)	I_n	25kA		
Max. discharge current (8/20)	I_{max}	100kA		
Impulse current (10/350)	I_{imp}	50kA		
Specific energy	W/R	625kJ/Ω		
Charge	Q	25As		
Protection level	U_p	< 0.6kV	< 1.2kV	< 1.9kV
Residual voltage at 5kA (8/20)	U_{res}	< 0.5kV	< 0.9kV	< 1.6kV
Follow current	I_{fi}	NO		
Response time	t_A	< 25ns		
Thermal protection		YES		
Back-up fuse (if mains > 500A)		500A gL		
TOV immunity (withstand for unlimited time up to)	U_T	300V	700V	900V
Mechanical characteristics				
Terminal screw torque		max. 3.0Nm		
Temperature range		- 40°C + 80°C		
Terminal cross section		35mm ² (solid) / 25mm ² (stranded)		
Mounting		35mm DIN rail, EN 60715		
Degree of protection		IP 20		
Housing material		thermoplastic; extinguishing degree UL 94 V-0		
Indication of disconnector operation		red flag		
Remote contacts (RC)		YES		
Contact ratings		AC: 250V/0.5A; 125V/3A		
Terminal cross section		max. 1.5mm ²		
Remote terminal torque		0.25Nm		

Ordering information

U_C	150	275	440
Ordering code SAFETEC B 50/xxx TCG	54.0306	54.0308	54.0310
Ordering code SAFETEC BR 50/xxx TCG (with remote contacts)	54.0307	54.0309	54.0311

TC solution available on request



Dimensions, Internal configuration, Weight and Packaging

SAFETEC B(R) 35/xxx TCG

Dimensions

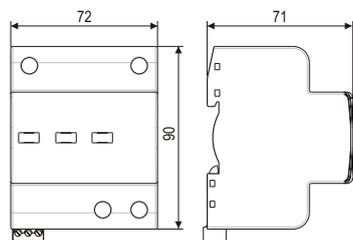

Internal configuration

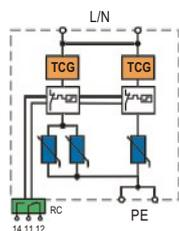

SAFETEC B 35/xxx TCG	150	275	440
Dimensions DIN 43880		4TE	
Weight per unit	410g	510g	700g
SAFETEC BR 35/xxx TCG	150	275	440
Dimensions DIN 43880		4TE	
Weight per unit	415g	515g	705g
Packaging dimensions (single unit)		109 x 76.5 x 78mm	
Min. packaging quantity		3 pcs.	

SAFETEC B(R) 50/xxx TCG

Dimensions

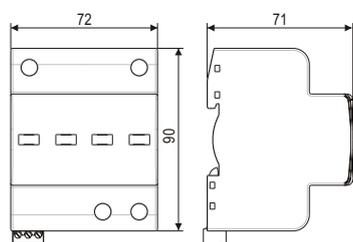

Internal configuration

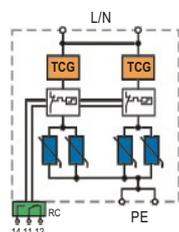

SAFETEC B 50/xxx TCG	150	275	440
Dimensions DIN 43880		4TE	
Weight per unit	750g	970g	1100g
SAFETEC BR 50/xxx TCG	150	275	440
Dimensions DIN 43880		4TE	
Weight per unit	760g	980g	1110g
Packaging dimensions (single unit)		109 x 76.5 x 78mm	
Min. packaging quantity		3 pcs.	

Class I, II Compact Single and Multi-pole SPD 12.5kA per pole



Category IEC / EN / VDE:	Class I, II / Type 1, 2 / B, C
Location of use:	Main distribution boards
Protection modes:	L/N-PE, L-PEN, L-N, N-PE
Protective elements:	High energy MOV and GDT
Surge discharge rating:	$I_{imp} = 12.5\text{kA}$
Internal protection and safety:	Separate thermal disconnecter for each MOV
Complies with:	IEC/EN 61643-11

PROTEC B2N(R) Series:
PROTEC B2N(R) 12.5/xxx
PROTUBE B2N 50

PROBLOC BS(R) Series:
PROBLOC BS(R) 25/xxx (2+0)
PROBLOC BS(R) 37.5/xxx (3+0)
PROBLOC BS(R) 50/xxx (4+0)
PROBLOC BS(R) 25/xxx (1+1)
PROBLOC BS(R) 50/xxx (3+1)

The PROTEC B2N(R) 12.5 kA and PROBLOC BS(R) 12.5 kA per pole series of overvoltage surge protective devices have been developed to protect against partial direct and indirect lightning discharges. They are suited for power supply installations and intended to provide protection in zones 0_A - 2 per IEC 62305.

PROBLOC BS(R) is a compact, multi-pole housing design and consists of a high performance varistors with thermal disconnection mechanism.

PROTEC B2N(R) is a compact, single pole housing design and consists of a high performance varistor with thermal disconnection mechanism.

PROTUBE B2N is a compact, single pole housing design and consists of a high energy encapsulated gas discharge tube. It is utilized for galvanic separation between the N and PE conductors in a 1+1 or 3+1 power distribution networks.

PROTEC B2N(R) 12.5 kA and PROBLOC BS(R) 12.5 kA per pole series comply with the IEC/EN 61643-11 standard and are applicable to the following connections: TN-S, TN-C, IT and TT.

PROTEC B2N(R)



- **Category IEC / EN / VDE:** Class I, II / Type 1, 2 / B, C
- **Location of use:** Main distribution boards
- **Network systems:** TN-S, TN-C, IT
- **Protection modes:** L/N - PE, L- PEN
- **Protective element:** High energy MOV
- **Surge discharge rating:** $I_{imp} = 12.5kA$
- **MOV max. withstand capability 1 x 8/20:** 80kA
- **Housing:** Compact design
- **Complies with:** IEC/EN 61643-11



Technical data

Type	PROTEC B2N(R) 12.5/xxx					
	150	275	320	385	440	
Electrical characteristics						
Max. continuous operating voltage (AC/DC)	U_C	150/200V	275/350V	320/420V	385/500V	440/580V
Nominal discharge current (8/20)	I_n	20kA				
Max. discharge current (8/20)	I_{max}	50kA				
Impulse current (10/350)	I_{imp}	12.5kA				
Specific energy	W/R	39kJ/Ω				
Charge	Q	6.25As				
Protection level	U_p	< 0.8kV	< 1.5kV	< 1.5kV	< 1.7kV	< 2.0kV
Residual voltage at I_{imp}	U_{res}	< 0.7kV	< 1.2kV	< 1.2kV	< 1.4kV	< 1.9kV
Residual voltage at 5kA (8/20)	U_{res}	< 0.6kV	< 1.0kV	< 1.0kV	< 1.2kV	< 1.4kV
Follow current	I_{fi}	NO				
Response time	t_A	< 25ns				
Thermal protection		YES				
Back-up fuse (if mains > 160A)		160A gL				
Short-circuit withstand current	I_{SCCR}	25kA/50Hz				
Mechanical characteristics						
Temperature range		- 40°C + 80°C				
Terminal screw torque		max. 3.0Nm				
Terminal cross section		35mm ² (solid)/25mm ² (stranded)				
Mounting		35mm DIN rail, EN 60715				
Degree of protection		IP 20				
Housing material		Thermoplastic; extinguishing degree UL 94 V-0				
Indication of disconnector operation		red flag				
Remote contacts (RC)		YES				
Contact ratings		AC: 250V/0.5A; 125V/3A				
Terminal cross section		max. 1.5mm ²				
Remote terminal torque		0.25Nm				

Ordering information

U_C	150	275	320	385	440
Ordering code PROTEC B2N 12.5/xxx	507.501	507.503	507.505	507.535	507.507
Ordering code PROTEC B2NR 12.5/xxx (with remote contacts)	507.509	507.511	507.513	507.537	507.515

PROTUBE B2N 50



- **Category IEC / EN / VDE:** Class I, II / Type 1, 2 / B, C
- **Location of use:** Main distribution boards
- **Network system:** TT
- **Protection modes:** N - PE
- **Protective element:** High energy GDT
- **Surge discharge rating:** $I_{imp} = 50kA$
- **GDT max. withstand capability 1 x 8/20:** 150kA
- **Housing:** Compact design
- **Complies with:** IEC/EN 61643-11



Technical data

Type		PROTUBE B2N 50	
Electrical characteristics			
Max. continuous operating voltage (AC/DC)	U_C		255V
Nominal discharge current (8/20)	I_n		50kA
Max. discharge current (8/20)	I_{max}		100kA
Impulse current (10/350)	I_{imp}		50kA
Specific energy	W/R		625kJ/Ω
Charge	Q		25As
Protection level	U_p		< 1.5kV
Residual voltage at 5kA (8/20)	U_{res}		< 0.2kV
Follow current	I_{fi}		100ARMS
Response time	t_A		100ns
Mechanical characteristics			
Temperature range			- 40°C + 80°C
Terminal screw torque			max. 3.0Nm
Terminal cross section			35mm ² (solid)/25mm ² (stranded)
Mounting			35mm DIN rail, EN 60715
Degree of protection			IP 20
Housing material			Thermoplastic; extinguishing degree UL 94 V-0

Ordering information

I_{imp}	50
Ordering code PROTUBE B2N 50	507.572

Dimensions, Internal configuration, Weight and Packaging

PROTEC B2N(R) 12.5

Dimensions

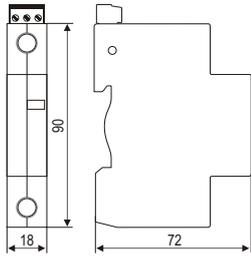

Internal configuration

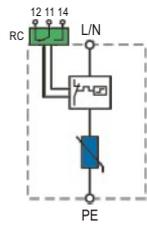

PROTEC B2N 12.5/xxx	150	275	320	385	440
Dimensions DIN 43880	1TE				
Weight per unit	124g	150g	150g	143g	146g
PROTEC B2NR 12.5/xxx	150	275	320	385	440
Dimensions DIN 43880	1TE				
Weight per unit	129g	155g	155g	148g	151g
Packaging dimensions (single unit)	108 x 74 x 24mm				
Min. packaging quantity	12 pcs.				

PROTUBE B2N 50

Dimensions

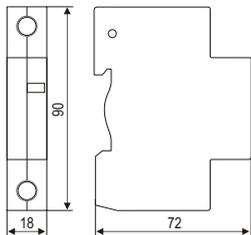

Internal configuration

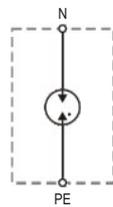

PROTUBE B2N 50	
Dimensions DIN 43880	1TE
Weight per unit	238g
Packaging dimensions (single unit)	109 x 76.5 x 24mm
Min. packaging quantity	7 pcs.

PROBLOC BS(R) (2+0)



- **Category IEC / EN / VDE:** Class I, II / Type 1, 2 / B, C
- **Location of use:** Main distribution boards
- **Network system:** TN-S
- **Protection modes:** L/N - PE
- **Protective element:** High energy MOV
- **Surge discharge rating:** $I_{imp} = 12.5kA$
- **MOV max. withstand capability 1 x 8/20:** 100kA per pole
- **Housing:** Compact design
- **Complies with:** IEC/EN 61643-11



Technical data

Type	PROBLOC BS(R) 25/xxx (2+0)					
	150	275	320	385	440	
Electrical characteristics						
Max. continuous operating voltage (AC/DC)	U_C	150/200V	275/350V	320/420V	385/500V	440/580V
Nominal discharge current (8/20)	I_n	20kA per pole				
Max. discharge current (8/20)	I_{max}	50kA per pole				
Impulse current (10/350)	I_{imp}	12.5kA per pole				
Specific energy	W/R	39kJ/Ω				
Charge	Q	6.25As				
Protection level	U_p	< 0.7kV	< 1.4kV	< 1.4kV	< 1.6kV	< 1.9kV
Residual voltage at I_{imp}	U_{res}	< 0.6kV	< 1.1kV	< 1.1kV	< 1.4kV	< 1.7kV
Residual voltage at 5kA (8/20)	U_{res}	< 0.6kV	< 1.1kV	< 1.1kV	< 1.2kV	< 1.3kV
Follow current	I_{fi}	NO				
Response time	t_A	< 25ns				
Thermal protection		YES				
Back-up fuse (if mains > 250A)		250A gL				
Short-circuit withstand current	I_{SCCR}	25kA/50Hz				
Mechanical characteristics						
Temperature range		- 40°C + 80°C				
Terminal screw torque		max. 3.0Nm				
Terminal cross section		35mm ² (solid)/25mm ² (stranded)				
Mounting		35mm DIN rail, EN 60715				
Degree of protection		IP 20				
Housing material		Thermoplastic; extinguishing degree UL 94 V-0				
Indication of disconnector operation		red flag				
Remote contacts (RC)		YES				
Contact ratings		AC: 250V/0.5A; 125V/3A				
Terminal cross section		max. 1.5mm ²				
Remote terminal torque		0.25Nm				

Ordering information

U_C	150	275	320	385	440
Ordering code PROBLOC BS 25/xxx (2+0)	504.405	504.406	504.407	504.408	504.409
Ordering code PROBLOC BSR 25/xxx (2+0) (with remote contacts)	504.420	504.421	504.422	504.423	504.424

PROBLOC BS(R) (3+0)



- **Category IEC / EN / VDE:** Class I, II / Type 1, 2 / B, C
- **Location of use:** Main distribution boards
- **Network systems:** TN-C, IT
- **Protection modes:** L - PEN
- **Protective element:** High energy MOV
- **Surge discharge rating:** $I_{imp} = 12.5kA$
- **MOV max. withstand capability 1 x 8/20:** 100kA per pole
- **Housing:** Compact design
- **Complies with:** IEC/EN 61643-11



Technical data

Type		150	275	320	385	440
		PROBLOC BS(R) 37.5/xxx (3+0)				
Electrical characteristics						
Max. continuous operating voltage (AC/DC)	U_C	150/200V	275/350V	320/420V	385/500V	440/580V
Nominal discharge current (8/20)	I_n	20kA per pole				
Max. discharge current (8/20)	I_{max}	50kA per pole				
Impulse current (10/350)	I_{imp}	12.5kA per pole				
Specific energy	W/R	39kJ/Ω				
Charge	Q	6.25As				
Protection level	U_p	< 0.9kV	< 1.4kV	< 1.4kV	< 1.8kV	< 2.1kV
Residual voltage at I_{imp}	U_{res}	< 0.7kV	< 1.2kV	< 1.2kV	< 1.5kV	< 1.8kV
Residual voltage at 5kA (8/20)	U_{res}	< 0.6kV	< 1.1kV	< 1.1kV	< 1.2kV	< 1.3kV
Follow current	I_{fi}	NO				
Response time	t_A	< 25ns				
Thermal protection		YES				
Back-up fuse (if mains > 250A)		250A gL				
Short-circuit withstand current	I_{SCCR}	25kA/50Hz				
Mechanical characteristics						
Temperature range		- 40°C + 80°C				
Terminal screw torque		max. 3.0Nm				
Terminal cross section		35mm ² (solid)/25mm ² (stranded)				
Mounting		35mm DIN rail, EN 60715				
Degree of protection		IP 20				
Housing material		Thermoplastic; extinguishing degree UL 94 V-0				
Indication of disconnector operation		red flag				
Remote contacts (RC)		YES				
Contact ratings		AC: 250V/0.5A; 125V/3A				
Terminal cross section		max. 1.5mm ²				
Remote terminal torque		0.25Nm				

Ordering information

U_C	150	275	320	385	440
Ordering code PROBLOC BS 37.5/xxx (3+0)	504.049	504.051	504.053	504.267	504.055
Ordering code PROBLOC BSR 37.5/xxx (3+0) (with remote contacts)	504.057	504.059	504.061	504.269	504.063

PROBLOC BS(R) (4+0)



- **Category IEC / EN / VDE:** Class I, II / Type 1, 2 / B, C
- **Location of use:** Main distribution boards
- **Network systems:** TN-S, IT
- **Protection modes:** L/N-PE
- **Protective element:** High energy MOV
- **Surge discharge rating:** $I_{imp} = 12.5kA$
- **MOV max. withstand capability 1 x 8/20:** 100kA per pole
- **Housing:** Compact design
- **Complies with:** IEC/EN 61643-11



Technical data

Type	PROBLOC BS(R) 50/xxx (4+0)					
	150	275	320	385	440	
Electrical characteristics						
Max. continuous operating voltage (AC/DC)	U_C	150/200V	275/350V	320/420V	385/500V	440/580V
Nominal discharge current (8/20)	I_n	20kA per pole				
Max. discharge current (8/20)	I_{max}	50kA per pole				
Impulse current (10/350)	I_{imp}	12.5kA per pole				
Specific energy	W/R	39kJ/Ω				
Charge	Q	6.25As				
Protection level	U_p	< 0.9kV	< 1.4kV	< 1.4kV	< 1.8kV	< 2.1kV
Residual voltage at I_{imp}	U_{res}	< 0.8kV	< 1.3kV	< 1.3kV	< 1.6kV	< 1.9kV
Residual voltage at 5kA (8/20)	U_{res}	< 0.6kV	< 1.1kV	< 1.1kV	< 1.2kV	< 1.3kV
Follow current	I_{fi}	NO				
Response time	t_A	< 25ns				
Thermal protection		YES				
Back-up fuse (if mains > 250A)		250A gL				
Short-circuit withstand current	I_{SCCR}	25kA/50Hz				
Mechanical characteristics						
Temperature range		- 40°C + 80°C				
Terminal screw torque		max. 3.0Nm				
Terminal cross section		35mm ² (solid)/25mm ² (stranded)				
Mounting		35mm DIN rail, EN 60715				
Degree of protection		IP 20				
Housing material		Thermoplastic; extinguishing degree UL 94 V-0				
Indication of disconnector operation		red flag				
Remote contacts (RC)		YES				
Contact ratings		AC: 250V/0.5A; 125V/3A				
Terminal cross section		max. 1.5mm ²				
Remote terminal torque		0.25Nm				

Ordering information

U_C	150	275	320	385	440
Ordering code PROBLOC BS 50/xxx (4+0)	504.065	504.067	504.069	504.271	504.071
Ordering code PROBLOC BSR 50/xxx (4+0) (with remote contacts)	504.073	504.075	504.077	504.273	504.079

Dimensions, Internal configuration, Weight and Packaging

PROBLOC BS(R) 25/xxx (2+0)

Dimensions

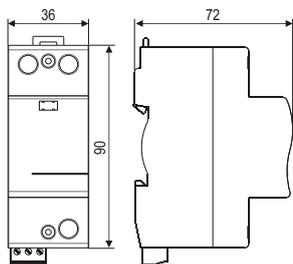

Internal configuration

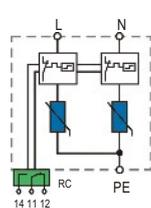

PROBLOC BS 25/xxx (2+0)	150	275	320	385	440
Dimensions DIN 43880	2TE				
Weight per unit	198g	251g	251g	267g	283g
PROBLOC BSR 25/xxx (2+0)	150	275	320	385	440
Dimensions DIN 43880	2TE				
Weight per unit	203g	256g	256g	272g	288g
Packaging dimensions (single unit)	109 x 76.5 x 41.5mm				
Min. packaging quantity	7 pcs.				

PROBLOC BS(R) 37.5/xxx (3+0)

Dimensions

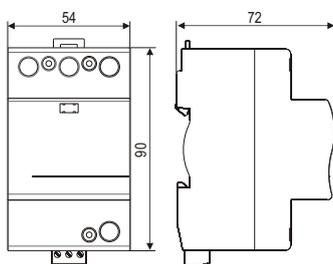

Internal configuration

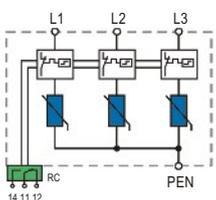

PROBLOC BS 37.5/xxx (3+0)	150	275	320	385	440
Dimensions DIN 43880	3TE				
Weight per unit	300g	382g	382g	394g	432g
PROBLOC BSR 37.5/xxx (3+0)	150	275	320	385	440
Dimensions DIN 43880	3TE				
Weight per unit	305g	387g	387g	399g	437g
Packaging dimensions (single unit)	109 x 76.5 x 60mm				
Min. packaging quantity	5 pcs.				

PROBLOC BS(R) 50/xxx (4+0)

Dimensions

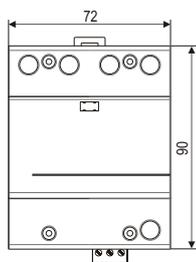

Internal configuration

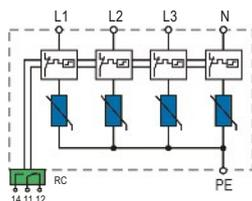

PROBLOC BS 50/xxx (4+0)	150	275	320	385	440
Dimensions DIN 43880	4TE				
Weight per unit	366g	462g	462g	494g	526g
PROBLOC BSR 50/xxx (4+0)	150	275	320	385	440
Dimensions DIN 43880	4TE				
Weight per unit	371g	467g	467g	499g	531g
Packaging dimensions (single unit)	109 x 76.5 x 78mm				
Min. packaging quantity	3 pcs.				

PROBLOC BS (1+1)



- **Category IEC / EN / VDE:** Class I, II / Type 1, 2 / B, C
- **Location of use:** Main distribution boards
- **Network system:** TT, TN-S
- **Protection modes:** L-N, N-PE
- **Protective element:** High energy MOV and GDT
- **Surge discharge rating:** $I_{imp} = 12.5kA/50kA (L-N/N-PE)$
- **MOV max. withstand capability 1 x 8/20:** 100kA per pole
- **Housing:** Compact design
- **Complies with:** IEC/EN 61643-11



Technical data

Type	PROBLOC BS 25/xxx (1+1)					
	150	275	320	385	440	
Electrical characteristics						
Max. continuous operating voltage (AC/DC)	U_c (L-N)	150/200V	275/350V	320/420V	385/500V	440/580V
	U_c (N-PE)	255V				
Nominal discharge current (8/20)	I_n (L-N/N-PE)	20kA/50kA				
Max. discharge current (8/20)	I_{max} (L-N/N-PE)	50kA/100kA				
Impulse current (10/350)	I_{imp} (L-N/N-PE)	12.5kA/50kA				
Specific energy	W/R (L-N/N-PE)	39kJ/Ω/6/25kJ/Ω				
Charge	Q (L-N/N-PE)	6.25As/25As				
Protection level	U_p (L-N)	< 0.7kV	< 1.4kV	< 1.4kV	< 1.6kV	< 1.9kV
	U_p (N-PE)	< 1.5kV				
Residual voltage at I_{imp}	U_{res} (L-N)	< 0.6kV	< 1.1kV	< 1.1kV	< 1.4kV	< 1.7kV
Residual voltage at 5kA (8/20)	U_{res} (L-N)	< 0.6kV	< 1.1kV	< 1.1kV	< 1.2kV	< 1.3kV
Follow current	I_{fi} (N-PE)	100ARMS				
Response time	t_A (L-N/N-PE)	< 25ns/100ns				
Thermal protection	(L-N)	YES				
Back-up fuse (if mains > 250A)	(L-N)	250A gL				
Short-circuit withstand current	I_{SCCR} (L-N)	25kA/50Hz				
Mechanical characteristics						
Temperature range	- 40°C + 80°C					
Terminal screw torque	max. 3.0Nm					
Terminal cross section	35mm ² (solid)/25mm ² (stranded)					
Mounting	35mm DIN rail, EN 60715					
Degree of protection	IP 20					
Housing material	Thermoplastic; extinguishing degree UL 94 V-0					
Indication of disconnector operation	red flag					

Ordering information

U_c	150	275	320	385	440
Ordering code PROBLOC BS 25/xxx (1+1)	504.410	504.411	504.412	504.413	504.414

PROBLOC BS(R) (3+1)



- **Category IEC / EN / VDE:** Class I, II / Type 1, 2 / B, C
- **Location of use:** Main distribution boards
- **Network system:** TT, TN-S
- **Protection modes:** L-N, N-PE
- **Protective element:** High energy MOV and GDT
- **Surge discharge rating:** $I_{imp} = 12.5kA/50kA (L-N/N-PE)$
- **MOV max. withstand capability 1 x 8/20:** 100kA per pole
- **Housing:** Compact design
- **Complies with:** IEC/EN 61643-11



Technical data

Type	PROBLOC BS(R) 50/xxx (3+1)					
	150	275	320	385	440	
Electrical characteristics						
Max. continuous operating voltage (AC/DC)	U_c (L-N)	150/200V	275/350V	320/420V	385/500V	440/580V
	U_c (N-PE)	255V				
Nominal discharge current (8/20)	I_n (L-N/N-PE)	20kA/50kA				
Max. discharge current (8/20)	I_{max} (L-N/N-PE)	50kA/100kA				
Impulse current (10/350)	I_{imp} (L-N/N-PE)	12.5kA/50kA				
Specific energy	W/R (L-N/N-PE)	39kJ/Ω/625kJ/Ω				
Charge	Q (L-N/N-PE)	6.25As/25As				
Protection level	U_p (L-N)	< 0.9kV	< 1.4kV	< 1.4kV	< 1.8kV	< 2.1kV
	U_p (N-PE)	< 1.5kV				
Residual voltage at I_{imp}	U_{res} (L-N)	< 0.7kV	< 1.2kV	< 1.2kV	< 1.5kV	< 1.8kV
Residual voltage at 5kA (8/20)	U_{res} (L-N)	< 0.6kV	< 1.1kV	< 1.1kV	< 1.2kV	< 1.3kV
Follow current	I_{fi} (N-PE)	100ARMS				
Response time	t_A (L-N/N-PE)	< 25ns/100ns				
Thermal protection	(L-N)	YES				
Back-up fuse (if mains > 250A)	(L-N)	250A gL				
Short-circuit withstand current	I_{SCCR} (L-N)	25kA/50Hz				
Mechanical characteristics						
Temperature range	- 40°C ... + 80°C					
Terminal screw torque	max. 3.0Nm					
Terminal cross section	35mm ² (solid)/25mm ² (stranded)					
Mounting	35mm DIN rail, EN 60715					
Degree of protection	IP 20					
Housing material	Thermoplastic; extinguishing degree UL 94 V-0					
Indication of disconnector operation	red flag					
Remote contacts (RC)	YES					
Contact ratings	AC: 250V/0.5A; 125V/3A					
Terminal cross section	max. 1.5mm ²					
Remote terminal torque	0.25Nm					

Ordering information

U_c	150	275	320	385	440
Ordering code PROBLOC BS 50/xxx (3+1)	504.480	504.481	504.482	504.483	504.484
Ordering code PROBLOC BSR 50/xxx (3+1) (with remote contacts)	504.485	504.486	504.487	504.488	504.489

Dimensions, Internal configuration, Weight and Packaging

PROBLOC BS 25/xxx (1+1)

Dimensions

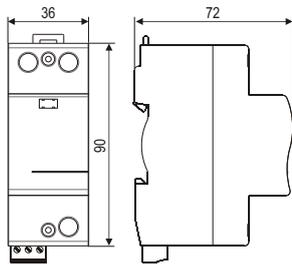

Internal configuration

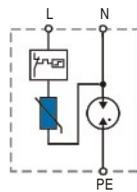

PROBLOC BS 25/xxx (1+1)	150	275	320	385	440
Dimensions DIN 43880	2TE				
Weight per unit	192g	245g	245g	261g	277g
Packaging dimensions (single unit)	109 x 76.5 x 41.5mm				
Min. packaging quantity	7 pcs.				

PROBLOC BS(R) 50/xxx (3+1)

Dimensions

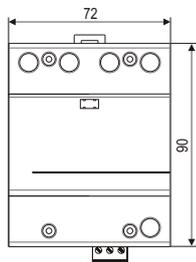

Internal configuration

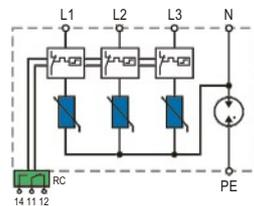

PROBLOC BS 50/xxx (3+1)	150	275	320	385	440
Dimensions DIN 43880	4TE				
Weight per unit	442g	538g	538g	548g	577g
PROBLOC BSR 50/xxx (3+1)	150	275	320	385	440
Dimensions DIN 43880	4TE				
Weight per unit	447g	543g	543g	553g	582g
Packaging dimensions (single unit)	109 x 76.5 x 78mm				
Min. packaging quantity	3 pcs.				

PROTEC B2N(R) and PROTUBE B2N

Network connections

TN-S Network - Single-phase

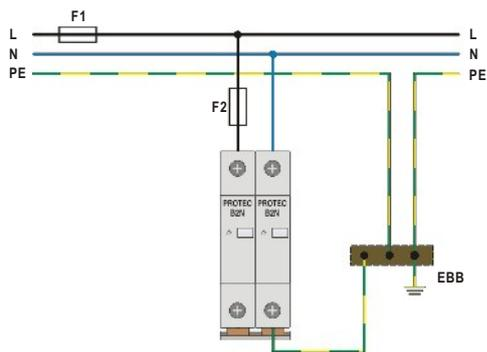

TN-S Network - Three-phase

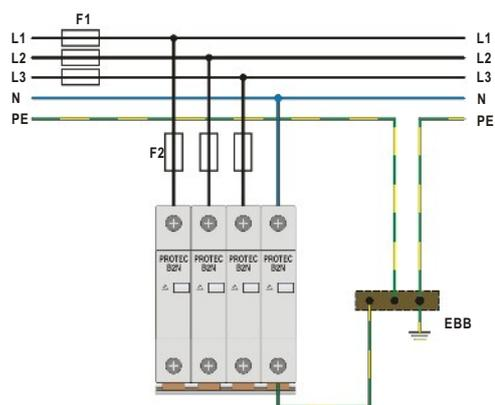

TN-C Network - Three-phase

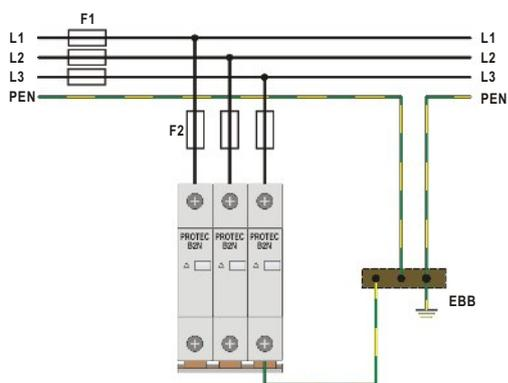

TT Network - Single-phase

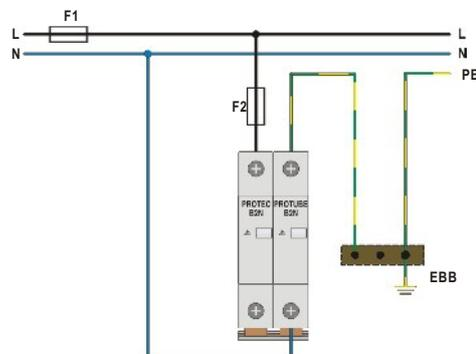

IT Network - Three-phase

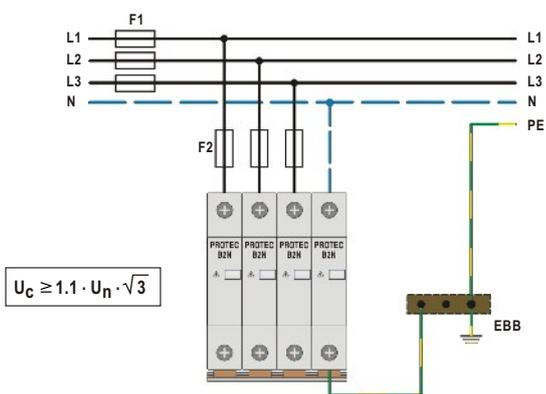

TT Network - Three-phase

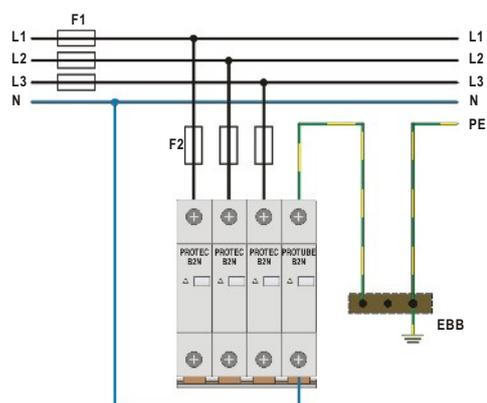

Back-up fuse

- F1 > 160 A gL → F2 = 160 A gL
- F1 ≤ 160 A gL → F2

PROBLOC BS(R) Series

Network connections

TN-S Network - Single-phase

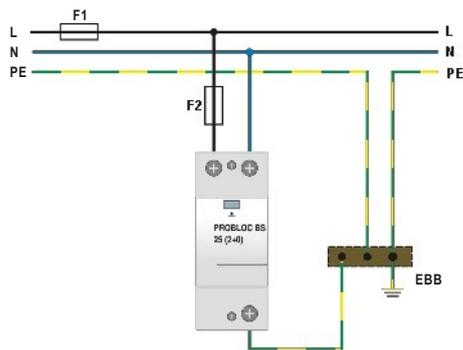

TN-S Network - Three-phase

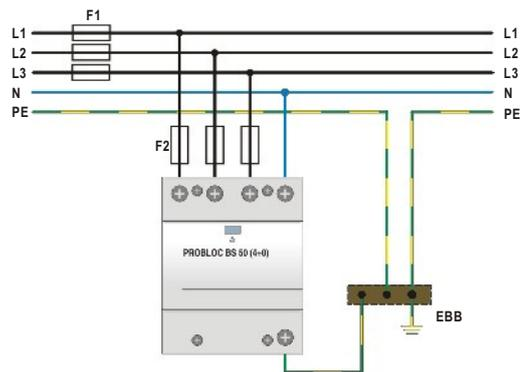

TN-C Network - Three-phase

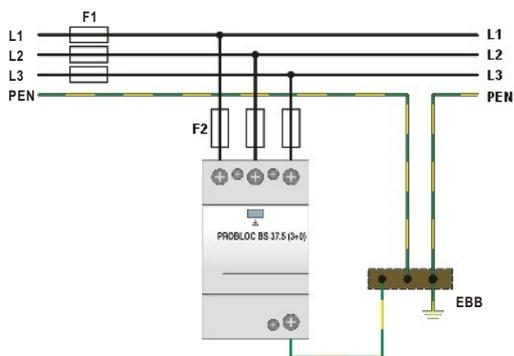

TT Network - Single-phase

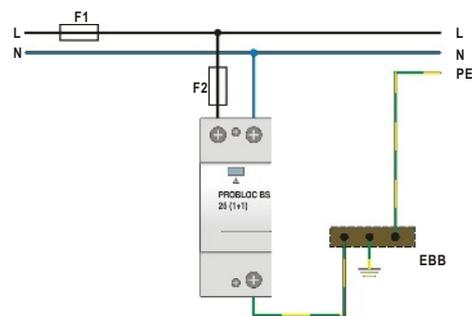

IT Network - Three-phase

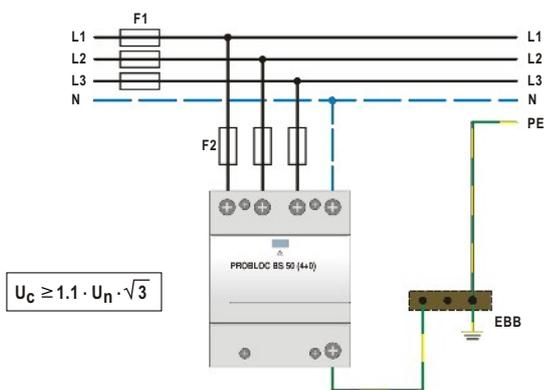

TT Network - Three-phase

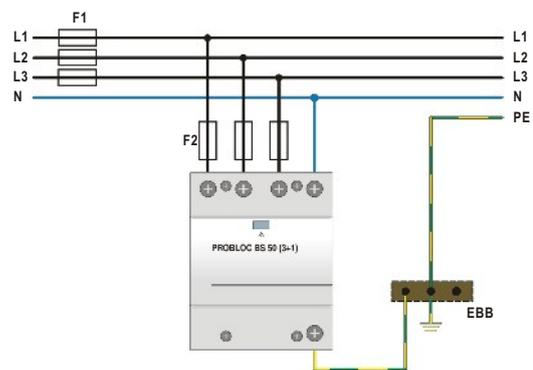

Back-up fuse

- F1 > 250 A gL → F2 = 250 A gL
- F1 ≤ 250 A gL → F2

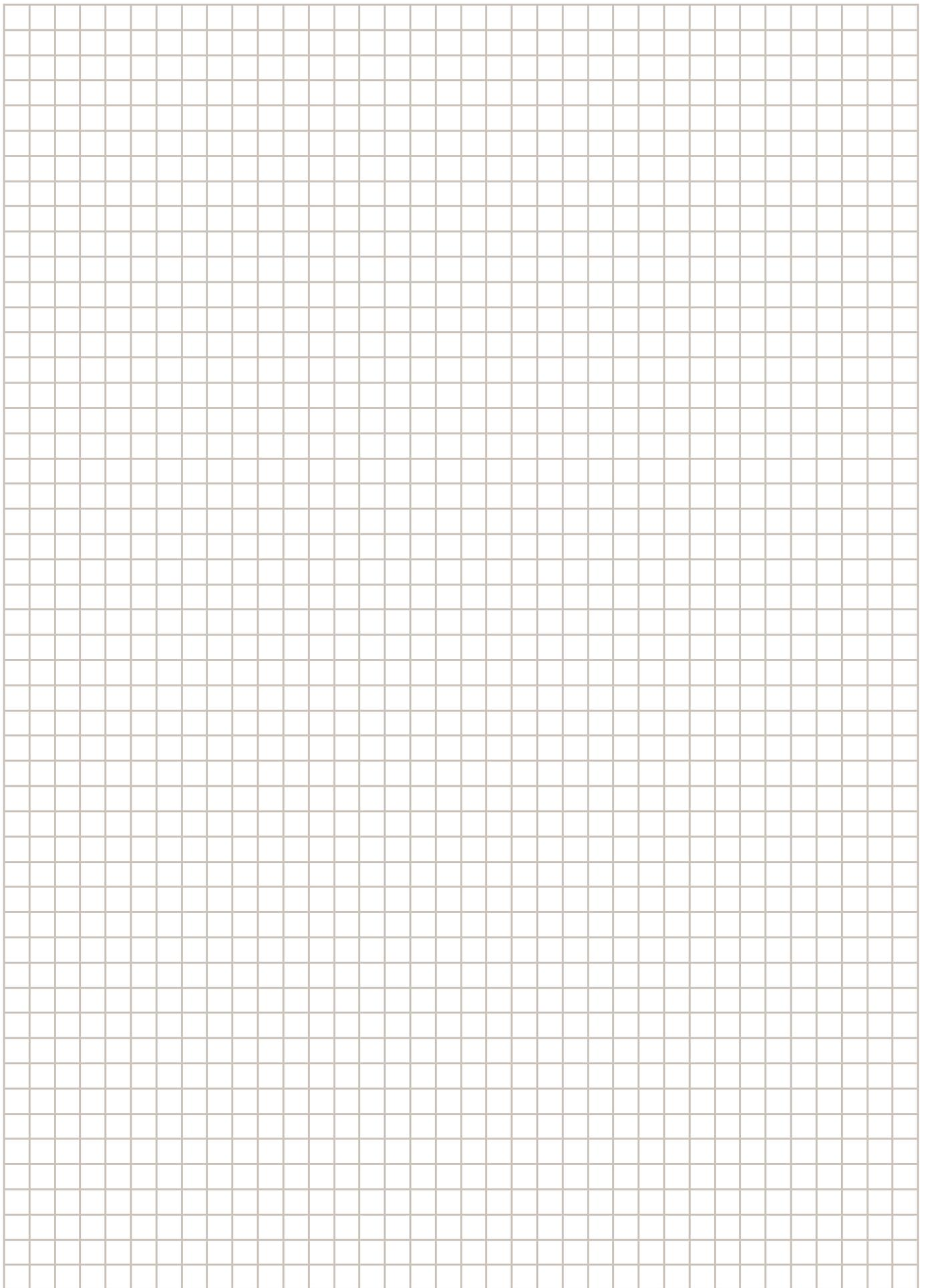

Class I, II Compact Single and Multi-pole SPD 25kA per pole



Category IEC / EN / VDE:

Location of use:

Protection modes:

Protective elements:

Surge discharge ratings:

Internal protection and safety:

Complies with:

Class I, II / Type 1, 2 / B, C

Main distribution boards

L/N-PE, L-PEN, L-N, N-PE

High energy MOV and GDT

Iimp up to 50kA

Separate thermal disconnecter for each MOV

IEC/EN 61643-11

PROTEC BS(R) Series:

PROTEC BS(R) 25/xxx

PROTUBE BS 50, 100

PROBLOC BS(R) Series:

PROBLOC BS(R) 50/xxx (2+0)

PROBLOC BS(R) 75/xxx (3+0)

PROBLOC BS(R) 100/xxx (4+0)

PROBLOC BS(R) 50/xxx (1+1)

PROBLOC BS(R) 100/xxx (3+1)

The PROTEC BS(R) 25 kA and PROBLOC BS(R) 25 kA per pole series of overvoltage surge protective devices have been developed to protect against partial direct and indirect lightning discharges. They are suited for power supply installations and intended to provide protection in zones 0_A - 2 per IEC 62305.

PROTEC BS(R) is a compact, single pole housing design and consists of a high performance paired varistors, each equipped with separate disconnection mechanism.

PROBLOC BS(R) is a compact, multi-pole housing design and consists of a high performance paired varistors combination, each equipped with separate disconnection mechanism.

PROTUBE BS is a compact, single pole housing design and consists of a high energy encapsulated gas discharge tube. It is utilized for galvanic separation between the N and PE conductors in a 1+1 or 3+1 power distribution networks.

PROTEC BS(R) 25 kA and PROBLOC BS(R) 25 kA per pole series comply with the IEC/EN 61643-11 standard and are applicable to the following connections: TN-S, TN-C, IT and TT.

PROTEC BS(R)



- **Category IEC / EN / VDE:** Class I, II / Type 1, 2 / B, C
- **Location of use:** Main distribution boards
- **Network systems:** TN-S, TN-C, IT
- **Protection modes:** L/N - PE, L- PEN
- **Protective element:** High energy MOV
- **Surge discharge rating:** $I_{imp} = 25kA$
- **MOV max. withstand capability 1 x 8/20:** 120kA
- **Housing:** Compact design
- **Complies with:** IEC/EN 61643-11



Technical data

Type	PROTEC BS(R) 25/xxx					
	150	275	320	385	440	
Electrical characteristics						
Max. continuous operating voltage (AC/DC)	U_C	150/200V	275/350V	320/420V	385/500V	440/580V
Nominal discharge current (8/20)	I_n	25kA				
Max. discharge current (8/20)	I_{max}	100kA				
Impulse current (10/350)	I_{imp}	25kA				
Specific energy	W/R	156kJ/Ω				
Charge	Q	12.5As				
Protection level	U_p	< 0.7kV	< 1.3kV	< 1.3kV	< 1.7kV	< 2.0kV
Residual voltage at I_{imp}	U_{res}	< 0.7kV	< 1.2kV	< 1.2kV	< 1.5kV	< 1.8kV
Residual voltage at 5kA (8/20)	U_{res}	< 0.5kV	< 1.0kV	< 1.0kV	< 1.1kV	< 1.2kV
Follow current	I_{fi}	NO				
Response time	t_A	< 25ns				
Thermal protection		YES				
Back-up fuse (if mains > 250A)		250A gL				
Short-circuit withstand current	I_{SCCR}	25kA/50Hz				
Mechanical characteristics						
Temperature range		- 40°C ... + 80°C				
Terminal screw torque		max. 3.0Nm				
Terminal cross section		35mm ² (solid)/25mm ² (stranded)				
Mounting		35mm DIN rail, EN 60715				
Degree of protection		IP 20				
Housing material		Thermoplastic; extinguishing degree UL 94 V-0				
Indication of disconnector operation		red flag				
Remote contacts (RC)		YES				
Contact ratings		AC: 250V/0.5A; 125V/3A				
Terminal cross section		max. 1.5mm ²				
Remote terminal torque		0.25Nm				

Ordering information

U_C	150	275	320	385	440
Ordering code PROTEC BS 25/xxx	502.326	502.327	502.328	502.329	502.330
Ordering code PROTEC BSR 25/xxx (with remote contacts)	502.331	502.332	502.333	502.334	502.335

PROTUBE BS



- Category IEC / EN / VDE: Class I, II / Type 1, 2 / B, C
- Location of use: Main distribution boards
- Network system: TT
- Protection modes: N - PE
- Protective element: High energy GDT
- Surge discharge rating: I_{imp} up to 100kA
- GDT max. withstand capability 1 x 8/20: 150kA
- Housing: Compact design
- Complies with: IEC/EN 61643-11



Technical data

Type	PROTUBE BS yyy		
	50		100
Electrical characteristics			
Max. continuous operating voltage (AC/DC)	U_C	255V	
Nominal discharge current (8/20)	I_n	50kA	100kA
Max. discharge current (8/20)	I_{max}	100kA	
Impulse current (10/350)	I_{imp}	50kA	100kA
Specific energy	W/R	625kJ/Ω	2.5MJ/Ω
Charge	Q	25As	50As
Protection level	U_p	< 1.5kV	< 1.75kV
Residual voltage at 5kA (8/20)	U_{res}	< 0.2kV	< 0.2kV
Follow current	I_{fi}	100ARMS	
Response time	t_A	100ns	
Mechanical characteristics			
Temperature range		- 40°C + 80°C	
Terminal screw torque		max. 3.0Nm	
Terminal cross section		35mm ² (solid)/25mm ² (stranded)	
Mounting		35mm DIN rail, EN 60715	
Degree of protection		IP 20	
Housing material		Thermoplastic; extinguishing degree UL 94 V-0	

Ordering information

I_{imp}	50	100
Ordering code PROTUBE BS yyy	5030.42	5030.44

Dimensions, Internal configuration, Weight and Packaging

PROTEC BS(R) 25

Dimensions

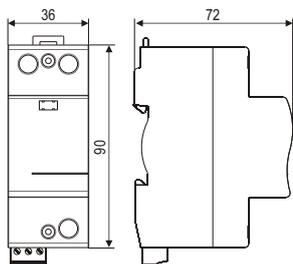

Internal configuration

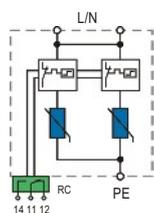

PROTEC BS 25/xxx	150	275	320	385	440
Dimensions DIN 43880	2TE				
Weight per unit	200g	252g	252g	268g	285g
PROTEC BSR 25/xxx	150	275	320	385	440
Dimensions DIN 43880	2TE				
Weight per unit	205g	257g	257g	273g	289g
Packaging dimensions (single unit)	109 x 76.5 x 41.5mm				
Min. packaging quantity	7 pcs.				

PROTUBE BS yyy

Dimensions

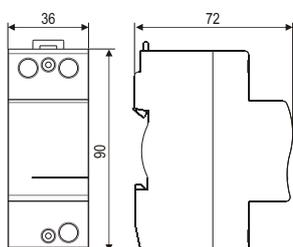

Internal configuration

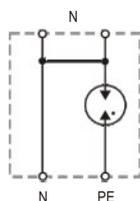

PROTUBE BS yyy	50	100
Dimensions DIN 43880	2TE	
Weight per unit	178g	238g
Packaging dimensions (single unit)	109 x 76.5 x 41.5mm	
Min. Packaging quantity	7 pcs.	

PROBLOC BS(R) (2+0)



- **Category IEC / EN / VDE:** Class I, II / Type 1, 2 / B, C
- **Location of use:** Main distribution boards
- **Network system:** TN-S
- **Protection modes:** L/N - PE
- **Protective element:** High energy MOV
- **Surge discharge rating:** $I_{imp} = 25kA$
- **MOV max. withstand capability 1 x 8/20:** 150kA per pole
- **Housing:** Compact design
- **Complies with:** IEC/EN 61643-11



Technical data

Type	PROBLOC BS(R) 50/xxx (2+0)					
	150	275	320	385	440	
Electrical characteristics						
Max. continuous operating voltage (AC/DC)	U_C	150/200V	275/350V	320/420V	385/500V	440/580V
Nominal discharge current (8/20)	I_n	25kA per pole				
Max. discharge current (8/20)	I_{max}	100kA per pole				
Impulse current (10/350)	I_{imp}	25kA per pole				
Specific energy	W/R	156kJ/Ω				
Charge	Q	12.5As				
Protection level	U_p	< 0.7kV	< 1.4kV	< 1.4kV	< 1.8kV	< 2.1kV
Residual voltage at I_{imp}	U_{res}	< 0.7kV	< 1.2kV	< 1.2kV	< 1.5kV	< 1.8kV
Residual voltage at 5kA (8/20)	U_{res}	< 0.5kV	< 1.0kV	< 1.0kV	< 1.1kV	< 1.2kV
Follow current	I_{fi}	NO				
Response time	t_A	< 25ns				
Thermal protection		YES				
Back-up fuse (if mains > 250A)		250A gL				
Short-circuit withstand current	I_{SCCR}	25kA/50Hz				
Mechanical characteristics						
Temperature range		- 40°C+ 80°C				
Terminal screw torque		max. 3.0Nm				
Terminal cross section		35mm ² (solid)/25mm ² (stranded)				
Mounting		35mm DIN rail, EN 60715				
Degree of protection		IP 20				
Housing material		Thermoplastic; extinguishing degree UL 94 V-0				
Indication of disconnector operation		red flag				
Remote contacts (RC)		YES				
Contact ratings		AC: 250V/0.5A; 125V/3A				
Terminal cross section		max. 1.5mm ²				
Remote terminal torque		0.25Nm				

Ordering information

U_C	150	275	320	385	440
Ordering code PROBLOC BS 50/xxx (2+0)	504.435	504.436	504.437	504.438	504.439
Ordering code PROBLOC BSR 50/xxx (2+0) (with remote contacts)	504.445	504.446	504.447	504.448	504.449

PROBLOC BS(R) (3+0)



- Category IEC / EN / VDE: Class I, II / Type 1, 2 / B, C
- Location of use: Main distribution boards
- Network systems: TN-C, IT
- Protection modes: L - PEN
- Protective element: High energy MOV
- Surge discharge rating: $I_{imp} = 25kA$
- MOV max. withstand capability 1 x 8/20: 150kA per pole
- Housing: Compact design
- Complies with: IEC/EN 61643-11



Technical data

Type	PROBLOC BS(R) 75/xxx (3+0)					
	150	275	320	385	440	
Electrical characteristics						
Max. continuous operating voltage (AC/DC)	U_C	150/200V	275/350V	320/420V	385/500V	440/580V
Nominal discharge current (8/20)	I_n	25kA per pole				
Max. discharge current (8/20)	I_{max}	100kA per pole				
Impulse current (10/350)	I_{imp}	25kA per pole				
Specific energy	W/R	156kJ/Ω				
Charge	Q	12.5As				
Protection level	U_p	< 0.8kV	< 1.4kV	< 1.4kV	< 1.9kV	< 2.2kV
Residual voltage at I_{imp}	U_{res}	< 0.8kV	< 1.3kV	< 1.3kV	< 1.6kV	< 1.9kV
Residual voltage at 5kA (8/20)	U_{res}	< 0.6kV	< 1.0kV	< 1.0kV	< 1.1kV	< 1.2kV
Follow current	I_{fi}	NO				
Response time	t_A	< 25ns				
Thermal protection		YES				
Back-up fuse (if mains > 250A)		250A gL				
Short-circuit withstand current	I_{SCCR}	25kA/50Hz				
Mechanical characteristics						
Temperature range		- 40°C + 80°C				
Terminal screw torque		max. 3.0Nm				
Terminal cross section		35mm ² (solid)/25mm ² (stranded)				
Mounting		35mm DIN rail, EN 60715				
Degree of protection		IP 20				
Housing material		Thermoplastic; extinguishing degree UL 94 V-0				
Indication of disconnector operation		red flag				
Remote contacts (RC)		YES				
Contact ratings		AC: 250V/0.5A; 125V/3A				
Terminal cross section		max. 1.5mm ²				
Remote terminal torque		0.25Nm				

Ordering information

U_C	150	275	320	385	440
Ordering code PROBLOC BS 75/xxx (3+0)	504.518	504.519	504.520	504.464	504.465
Ordering code PROBLOC BSR 75/xxx (3+0) (with remote contacts)	504.521	504.522	504.523	504.466	504.467

PROBLOC BS(R) (4+0)



- Category IEC / EN / VDE: Class I, II / Type 1, 2 / B, C
- Location of use: Main distribution boards
- Network systems: TN-S, IT
- Protection modes: L/N-PE
- Protective element: High energy MOV
- Surge discharge rating: $I_{imp} = 25kA$
- MOV max. withstand capability 1 x 8/20: 150kA per pole
- Housing: Compact design
- Complies with: IEC/EN 61643-11



Technical data

Type	PROBLOC BS(R) 100/xxx (4+0)					
	150	275	320	385	440	
Electrical characteristics						
Max. continuous operating voltage (AC/DC)	U_C	150/200V	275/350V	320/420V	385/500V	440/580V
Nominal discharge current (8/20)	I_n	25kA per pole				
Max. discharge current (8/20)	I_{max}	100kA per pole				
Impulse current (10/350)	I_{imp}	25kA per pole				
Specific energy	W/R	156kJ/Ω				
Charge	Q	12.5As				
Protection level	U_p	< 0.8kV	< 1.4kV	< 1.4kV	< 1.9kV	< 2.2kV
Residual voltage at I_{imp}	U_{res}	< 0.8kV	< 1.3kV	< 1.3kV	< 1.6kV	< 1.9kV
Residual voltage at 5kA (8/20)	U_{res}	< 0.6kV	< 1.0kV	< 1.0kV	< 1.1kV	< 1.2kV
Follow current	I_{fi}	NO				
Response time	t_A	< 25ns				
Thermal protection		YES				
Back-up fuse (if mains > 250A)		250A gL				
Short-circuit withstand current	I_{SCCR}	25kA/50Hz				
Mechanical characteristics						
Temperature range		- 40°C + 80°C				
Terminal screw torque		max. 3.0Nm				
Terminal cross section		35mm ² (solid)/25mm ² (stranded)				
Mounting		35mm DIN rail, EN 60715				
Degree of protection		IP 20				
Housing material		Thermoplastic; extinguishing degree UL 94 V-0				
Indication of disconnector operation		red flag				
Remote contacts (RC)		YES				
Contact ratings		AC: 250V/0.5A; 125V/3A				
Terminal cross section		max. 1.5mm ²				
Remote terminal torque		0.25Nm				

Ordering information

U_C	150	275	320	385	440
Ordering code PROBLOC BS 100/xxx (4+0)	504.524	504.525	504.526	504.468	504.469
Ordering code PROBLOC BSR 100/xxx (4+0) (with remote contacts)	504.527	504.528	504.529	504.470	504.471

Dimensions, Internal configuration, Weight and Packaging

PROBLOC BS(R) 50/xxx (2+0)

Dimensions

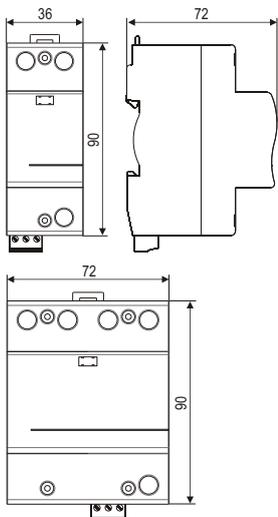

Internal configuration

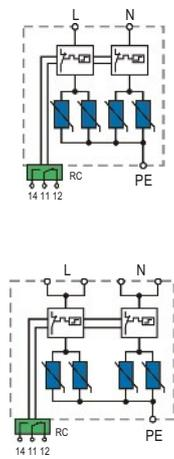

PROBLOC BS 50/xxx (2+0)	150	275	320
Dimensions DIN 43880	2TE		
Weight per unit	266g	374g	374g
PROBLOC BSR 50/xxx (2+0)	150	275	320
Dimensions DIN 43880	2TE		
Weight per unit	271g	379g	379g
Packaging dimensions (single unit)	109 x 76.5 x 41.5mm		
Min. packaging quantity	7 pcs.		

PROBLOC BS 50/xxx (2+0)	385	440	
Dimensions DIN 43880	4TE		
Weight per unit	438g	458g	
PROBLOC BSR 50/xxx (2+0)	385	440	
Dimensions DIN 43880	4TE		
Weight per unit	443g	463g	
Packaging dimensions (single unit)	109 x 76.5 x 78mm		
Min. packaging quantity	3 pcs.		

PROBLOC BS(R) 75/xxx (3+0)

Dimensions

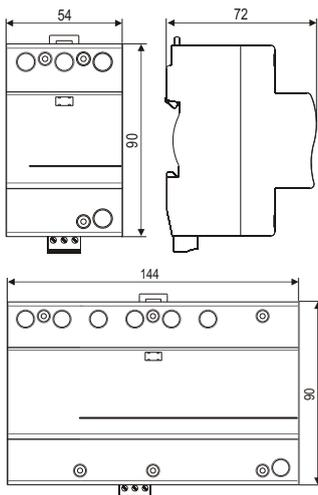

Internal configuration

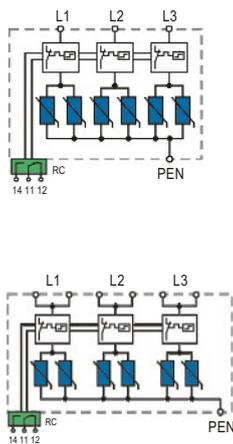

PROBLOC BS 75/xxx (3+0)	150	275	320
Dimensions DIN 43880	3TE		
Weight per unit	400g	570g	570g
PROBLOC BSR 75/xxx (3+0)	150	275	320
Dimensions DIN 43880	3TE		
Weight per unit	405g	575g	575g
Packaging dimensions (single unit)	109 x 76.5 x 60mm		
Min. packaging quantity	5 pcs.		

PROBLOC BS 75/xxx (3+0)	385	440	
Dimensions DIN 43880	8TE		
Weight per unit	726g	792g	
PROBLOC BSR 75/xxx (3+0)	385	440	
Dimensions DIN 43880	8TE		
Weight per unit	731g	797g	
Packaging dimensions (single unit)	109 x 76.5 x 148mm		
Min. packaging quantity	2 pcs.		

PROBLOC BS(R) 100/xxx (4+0)

Dimensions

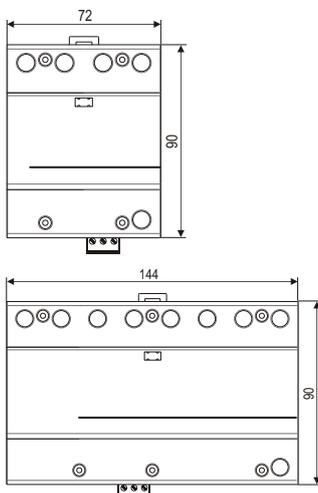

Internal configuration

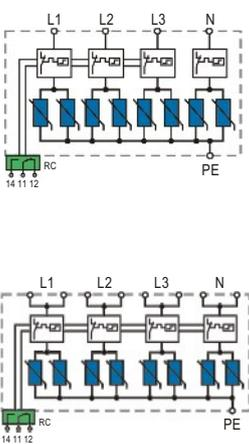

PROBLOC BS 100/xxx (4+0)	150	275	320
Dimensions DIN 43880	4TE		
Weight per unit	532g	756g	756g
PROBLOC BSR 100/xxx (4+0)	150	275	320
Dimensions DIN 43880	4TE		
Weight per unit	537g	761g	761g
Packaging dimensions (single unit)	109 x 76.5 x 78mm		
Min. packaging quantity	3 pcs.		

PROBLOC BS 100/xxx (4+0)	385	440	
Dimensions DIN 43880	8TE		
Weight per unit	912g	1000g	
PROBLOC BSR 100/xxx (4+0)	385	440	
Dimensions DIN 43880	8TE		
Weight per unit	917g	1005g	
Packaging dimensions (single unit)	109 x 76.5 x 148mm		
Min. packaging quantity	2 pcs.		

PROBLOC BS(R) (1+1)



- **Category IEC / EN / VDE:** Class I, II / Type 1, 2 / B, C
- **Location of use:** Main distribution boards
- **Network system:** TT, TN-S
- **Protection modes:** L-N, N-PE
- **Protective element:** High energy MOV and GDT
- **Surge discharge rating:** $I_{imp} = 25kA/50kA (L-N/N-PE)$
- **MOV max. withstand capability 1 x 8/20:** 150kA per pole
- **Housing:** Compact design
- **Complies with:** IEC/EN 61643-11



Technical data

Type	PROBLOC BS(R) 50/xxx (1+1)					
	150	275	320	385	440	
Electrical characteristics						
Max. continuous operating voltage (AC/DC)	U_c (L-N)	150/200V	275/350V	320/420V	385/500V	440/580V
	U_c (N-PE)	255V				
Nominal discharge current (8/20)	I_n (L-N/N-PE)	25kA/50kA				
Max. discharge current (8/20)	I_{max} (L-N/N-PE)	100kA/100kA				
Impulse current (10/350)	I_{imp} (L-N/N-PE)	25kA/50kA				
Specific energy	W/R (L-N/N-PE)	156kJ/Ω/625kJ/Ω				
Charge	Q (L-N/N-PE)	12.5As/25As				
Protection level	U_p (L-N)	< 0.8kV	< 1.4kV	< 1.4kV	< 1.8kV	< 2.1kV
	U_p (N-PE)	< 1.5kV				
Residual voltage at I_{imp}	U_{res} (L-N)	< 0.8kV	< 1.3kV	< 1.3kV	< 1.6kV	< 1.9kV
Residual voltage at 5kA (8/20)	U_{res}	< 0.6kV	< 1.0kV	< 1.0kV	< 1.1kV	< 1.2kV
Follow current	I_{fi} (N-PE)	100ARMS				
Response time	t_A (L-N/N-PE)	< 25ns/100ns				
Thermal protection	(L-N)	YES				
Back-up fuse (if mains > 250A)	(L-N)	250A gL				
Short-circuit withstand current	I_{SCCR} (L-N)	25kA/50Hz				
Mechanical characteristics						
Temperature range	- 40°C+ 80°C					
Terminal screw torque	max. 3.0Nm					
Terminal cross section	35mm ² (solid)/25mm ² (stranded)					
Mounting	35mm DIN rail, EN 60715					
Degree of protection	IP 20					
Housing material	Thermoplastic; extinguishing degree UL 94 V-0					
Indication of disconnector operation	red flag					
Remote contacts (RC)	YES					
Contact ratings	AC: 250V/0.5A; 125V/3A					
Terminal cross section	max. 1.5mm ²					
Remote terminal torque	0.25Nm					

Ordering information

U_c	150	275	320	385	440
Ordering code PROBLOC BS 50/xxx (1+1)	504.454	504.455	504.456	504.457	504.458
Ordering code PROBLOC BSR 50/xxx (1+1) (with remote contacts)	504.459	504.460	504.461	504.462	504.463

PROBLOC BS(R) (3+1)



- **Category IEC / EN / VDE:** Class I, II / Type 1, 2 / B, C
- **Location of use:** Main distribution boards
- **Network system:** TT, TN-S
- **Protection modes:** L-N, N-PE
- **Protective element:** High energy MOV and GDT
- **Surge discharge rating:** $I_{imp} = 25kA/50kA (L-N/N-PE)$
- **MOV max. withstand capability 1 x 8/20:** 150kA per pole
- **Housing:** Compact design
- **Complies with:** IEC/EN 61643-11



Technical data

Type		150	275	320	385	440
Electrical characteristics						
Max. continuous operating voltage (AC/DC)	U_c (L-N)	150/200V	275/350V	320/420V	385/500V	440/580V
	U_c (N-PE)	255V				
Nominal discharge current (8/20)	I_n (L-N/N-PE)	25kA/100kA				
Max. discharge current (8/20)	I_{max} (L-N/N-PE)	100kA/100kA				
Impulse current (10/350)	I_{imp} (L-N/N-PE)	25kA/100kA				
Specific energy	W/R (L-N/N-PE)	156kJ/Ω/625kJ/Ω				
Charge	Q (L-N/N-PE)	12.5As/25As				
Protection level	U_p (L-N)	< 0.9kV	< 1.4kV	< 1.4kV	< 1.9kV	< 2.2kV
	U_p (N-PE)	< 1.75kV				
Residual voltage at I_{imp}	U_{res} (L-N)	< 0.7kV	< 1.2kV	< 1.2kV	< 1.5kV	< 1.8kV
Residual voltage at 5kA (8/20)	U_{res}	< 0.5kV	< 1.0kV	< 1.0kV	< 1.1kV	< 1.2kV
Follow current	I_{fi} (N-PE)	100ARMS				
Response time	t_A (L-N/N-PE)	< 25ns/100ns				
Thermal protection	(L-N)	YES				
Back-up fuse (if mains > 250A)	(L-N)	250A gL				
Short-circuit withstand current	I_{SCCR} (L-N)	25kA/50Hz				
Mechanical characteristics						
Temperature range		- 40°C + 80°C				
Terminal screw torque		max. 3.0Nm				
Terminal cross section		35mm ² (solid)/25mm ² (stranded)				
Mounting		35mm DIN rail, EN 60715				
Degree of protection		IP 20				
Housing material		Thermoplastic; extinguishing degree UL 94 V-0				
Indication of disconnecter operation		red flag				
Remote contacts (RC)		YES				
Contact ratings		AC: 250V/0.5A; 125V/3A				
Terminal cross section		max. 1.5mm ²				
Remote terminal torque		0.25Nm				

Ordering information

U_c	150	275	320	385	440
Ordering code PROBLOC BS 100/xxx (3+1)	504.530	504.531	504.532	504.472	504.473
Ordering code PROBLOC BSR 100/xxx (3+1) (with remote contacts)	504.533	504.534	504.535	504.474	504.475

Dimensions, Internal configuration, Weight and Packaging

PROBLOC BS(R) 50/xxx (1+1)

Dimensions

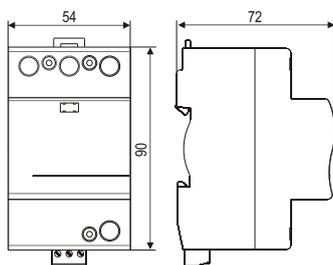

Internal configuration

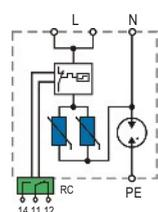

PROBLOC BS 50/xxx (1+1)	150	275	320	385	440
Dimensions DIN 43880	3TE				
Weight per unit	308g	364g	364g	386g	408g
PROBLOC BSR 50/xxx (1+1)	150	275	320	385	440
Dimensions DIN 43880	3TE				
Weight per unit	313g	369g	369g	391g	414g
Packaging dimensions (single unit)	109 x 76.5 x 60mm				
Min. packaging quantity	5 pcs.				

PROBLOC BS(R) 100/xxx (3+1)

Dimensions

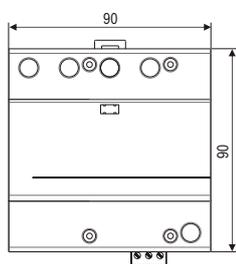

Internal configuration

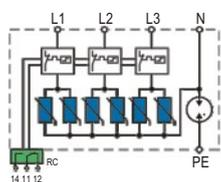

PROBLOC BS 100/xxx (3+1)	150	275	320
Dimensions DIN 43880	5TE		
Weight per unit	568g	728g	728g
PROBLOC BSR 100/xxx (3+1)	150	275	320
Dimensions DIN 43880	5TE		
Weight per unit	573g	733g	733g
Packaging dimensions (single unit)	109 x 76.5 x 96mm		
Min. packaging quantity	3 pcs.		

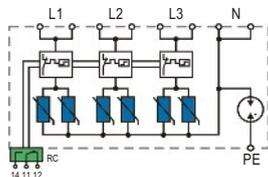
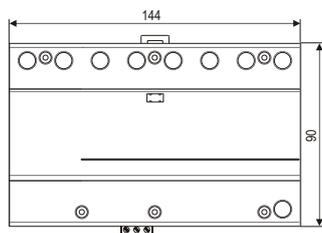

PROBLOC BS 100/xxx (3+1)	385	440
Dimensions DIN 43880	8TE	
Weight per unit	834g	900g
PROBLOC BSR 100/xxx (3+1)	385	440
Dimensions DIN 43880	8TE	
Weight per unit	839g	905g
Packaging dimensions (single unit)	109 x 76.5 x 148mm	
Min. packaging quantity	2 pcs.	

PROTEC BS(R) and PROTUBE BS

Network connections

TN-S Network - Single-phase (T-connection)

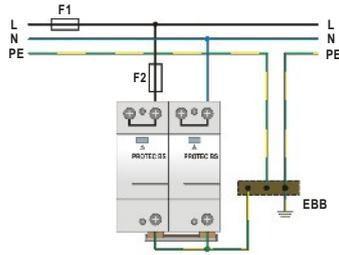

TN-S Network - Single-phase (V-connection)

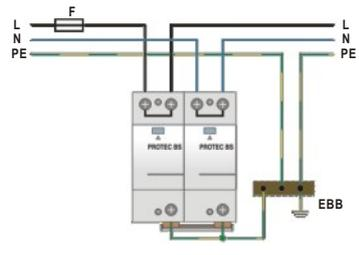

TT Network - Single-phase (T-connection)

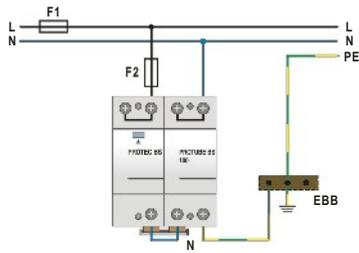

TT Network - Single-phase (V-connection)

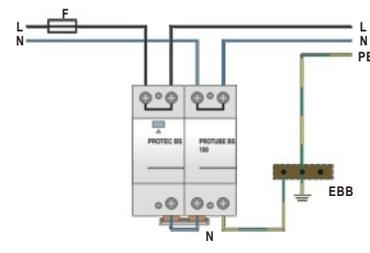

TN-C Network - Three-phase (T-connection)

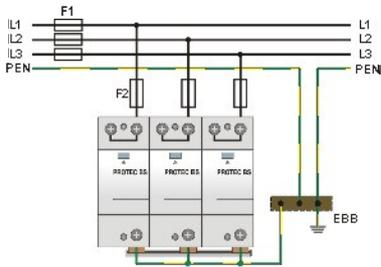

TN-C Network - Three-phase (V-connection)

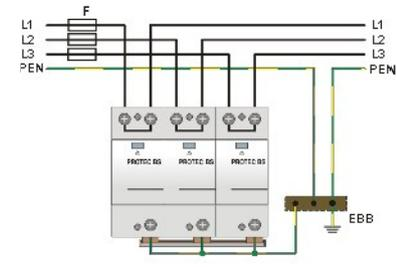

TN-S Network - Three-phase (T-connection)

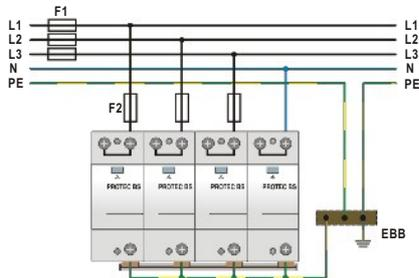

TN-S Network - Three-phase (V-connection)

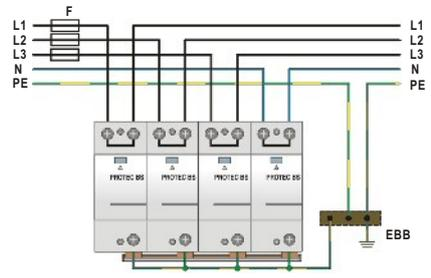

IT Network - Three-phase (T-connection)

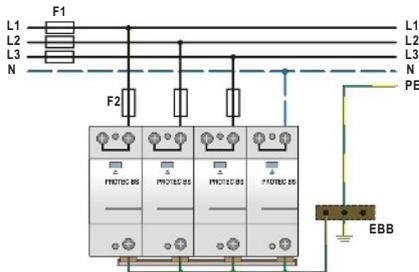

IT Network - Three-phase (V-connection)

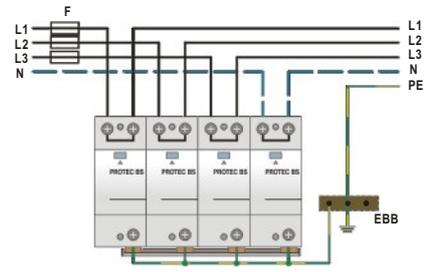

$$U_c \geq 1.1 \cdot U_n \cdot \sqrt{3}$$

TT Network - Three-phase (T-connection)

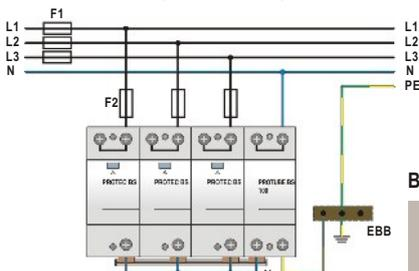

TT Network - Three-phase (V-connection)

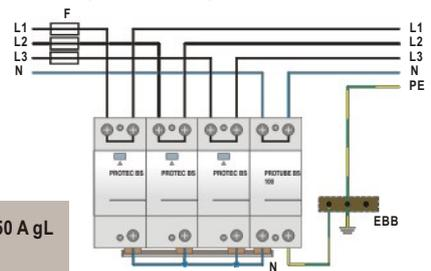

Back-up fuse

- $F1 > 250 \text{ A gL}$ → $F2 = 250 \text{ A gL}$
- $F1 \leq 250 \text{ A gL}$ → $F2$

PROBLOC BS(R) Series

Network connections

TN-S Network - Single-phase (T-connection)

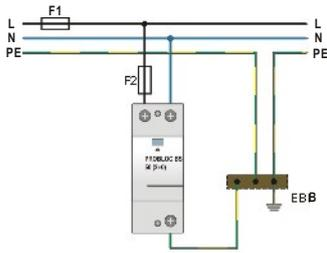

TN-S Network - Single-phase (V-connection)

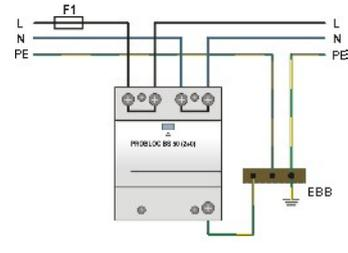

TN-C Network - Three-phase (T-connection)

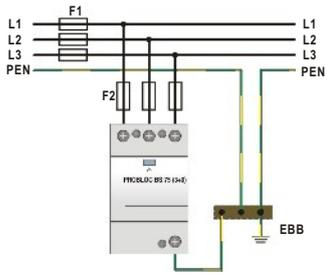

TN-C Network - Three-phase (V-connection)

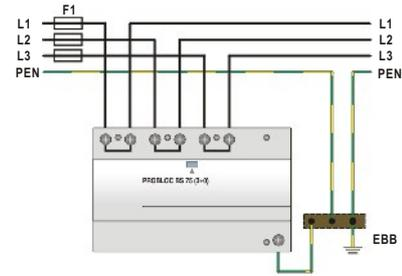

TN-S Network - Three-phase (T-connection)

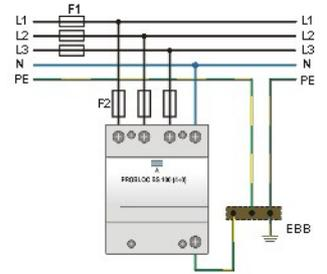

TN-S Network - Three-phase (V-connection)

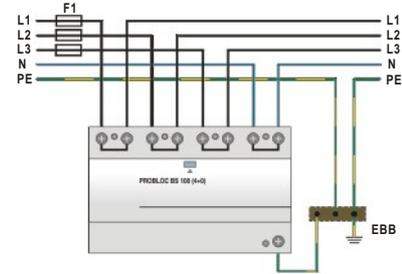

TT Network - Single-phase (T-connection)

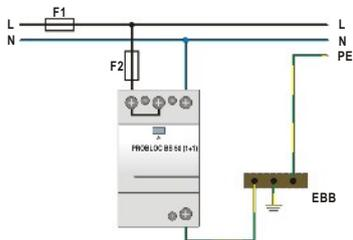

TT Network - Three-phase (T-connection)

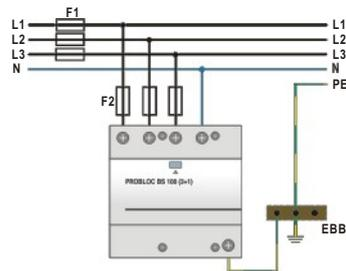

TT Network - Three-phase (V-connection)

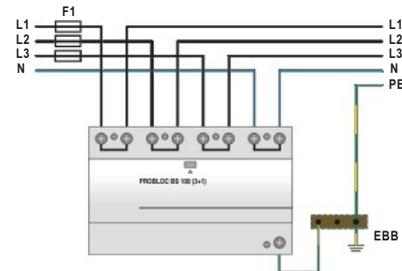

IT Network - Three-phase (T-connection)

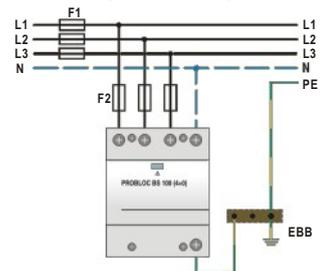

IT Network - Three-phase (V-connection)

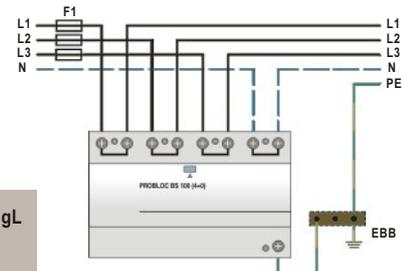

$$U_c \geq 1.1 \cdot U_n \cdot \sqrt{3}$$

Back-up fuse

- $F1 > 250 \text{ A gL}$ → $F2 = 250 \text{ A gL}$
- $F1 \leq 250 \text{ A gL}$ → $F2$

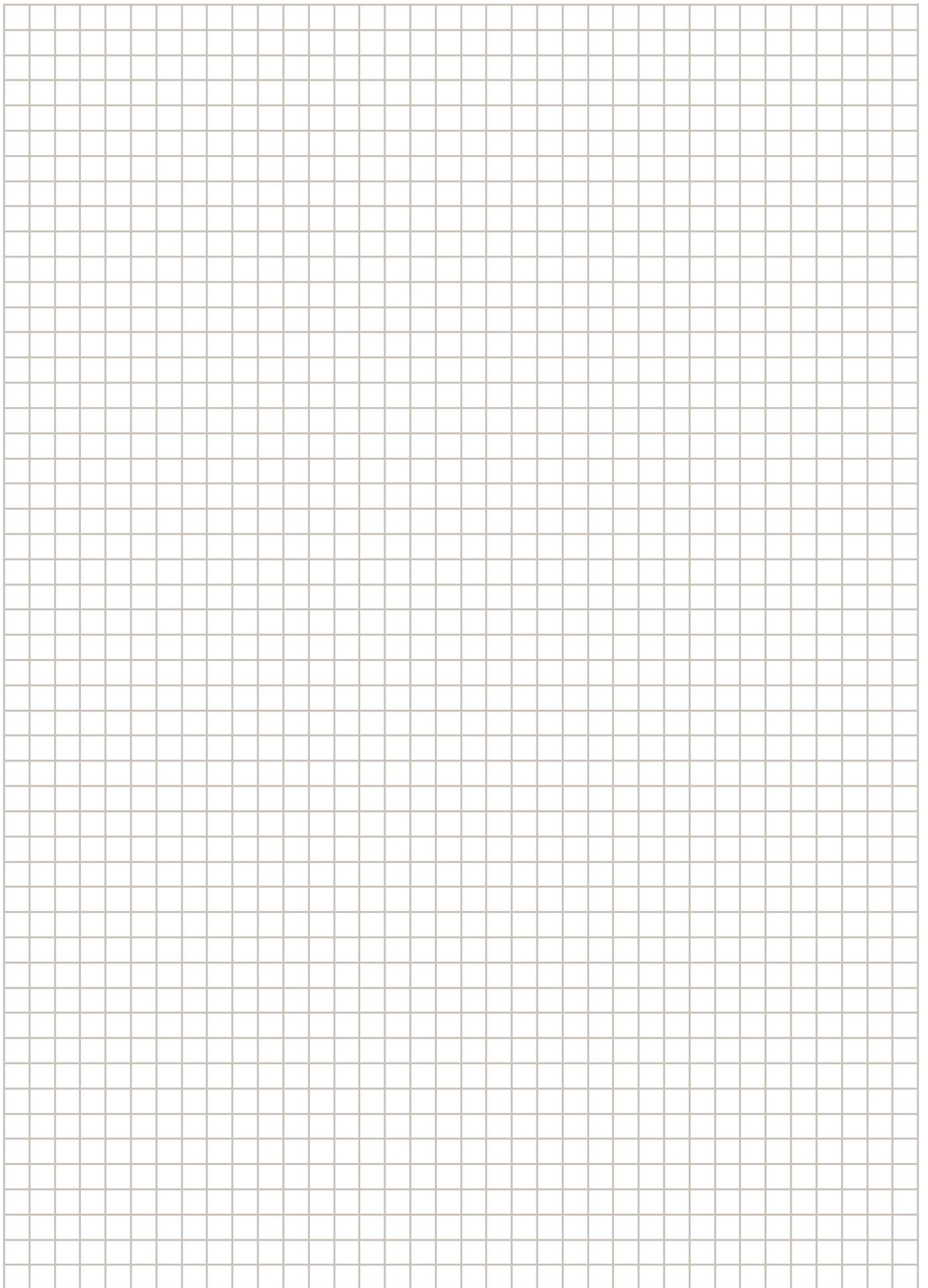

Class I, II Compact Single and Multi-pole SPD up to 50kA per pole



Category IEC / EN / VDE:

Location of use:

Protection modes:

Protective elements:

Surge discharge ratings:

Internal protection and safety:

Complies with:

Class I, II / Type 1, 2 / B, C

Main distribution boards

L/N-PE, L-PEN, L-N, N-PE

High energy MOV and GDT

Iimp up to 50kA

Separate thermal disconnecter for each MOV

IEC/EN 61643-11

PROTEC BS(R) 35/xxx

PROTEC BS(R) 50/xxx

PROBLOC BS(R) 100/xxx (1+1)

The PROTEC BS(R) 35kA, PROTEC(R) 50kA and PROBLOC(R) BS 100kA series of overvoltage surge protective devices have been developed to protect against partial direct and indirect lightning discharges. They are suited for power supply installations and intended to provide protection in zones 0_A - 2 per IEC 62305.

PROTEC BS(R) 35 consists of single high performance varistor and a paired varistors combination, each with a separate disconnection mechanism.

PROTEC BS(R) 50 consists of two paired, high performance varistors, with a separate disconnection mechanism included.

PROBLOC BS(R) 100 (1+1) consists of two paired, high performance varistors with thermal disconnection mechanism and gas discharge tube.

PROTEC BS(R) 35, PROTEC BS(R) 50 and PROBLOC(R) 100 (1+1) comply with the IEC/EN 61643-11 standard and are applicable to the following connections: TN-S, TN-C, IT and TT.

PROTEC BS(R)



- **Category IEC / EN / VDE:** Class I, II / Type 1, 2 / B, C
- **Location of use:** Main distribution boards
- **Network systems:** TN-S, TN-C, IT
- **Protection modes:** L/N - PE, L- PEN
- **Protective element:** High energy MOV
- **Surge discharge rating:** $I_{imp} = 35kA$
- **MOV max. withstand capability 1 x 8/20:** 150kA
- **Housing:** Compact design
- **Complies with:** IEC/EN 61643-11



Technical data

Type	PROTEC BS(R) 35/xxx					
	150	275	320	385	440	
Electrical characteristics						
Max. continuous operating voltage (AC/DC)	U_C	150/200V	275/350V	320/420V	385/500V	440/580V
Nominal discharge current (8/20)	I_n	25kA				
Max. discharge current (8/20)	I_{max}	100kA				
Impulse current (10/350)	I_{imp}	35kA				
Specific energy	W/R	306kJ/Ω				
Charge	Q	17.5As				
Protection level	U_p	< 0.6kV	< 1.2kV	< 1.2kV	< 1.6kV	< 1.9kV
Residual voltage at I_{imp}	U_{res}	< 0.7kV	< 1.2kV	< 1.2kV	< 1.5kV	< 1.8kV
Residual voltage at 5kA (8/20)	U_{res}	< 0.6kV	< 0.9kV	< 0.9kV	< 1.3kV	< 1.6kV
Follow current	I_{fi}	NO				
Response time	t_A	< 25ns				
Thermal protection		YES				
Back-up fuse (if mains > 250A)		250A gL				
Short-circuit withstand current	I_{SCCR}	25kA/50Hz				
Mechanical characteristics						
Temperature range		- 40°C+ 80°C				
Terminal screw torque		max. 3.0Nm				
Terminal cross section		35mm ² (solid)/25mm ² (stranded)				
Mounting		35mm DIN rail, EN 60715				
Degree of protection		IP 20				
Housing material		Thermoplastic; extinguishing degree UL 94 V-0				
Indication of disconnector operation		red flag				
Remote contacts (RC)		YES				
Contact ratings		AC: 250V/0.5A; 125V/3A				
Terminal cross section		max. 1.5mm ²				
Remote terminal torque		0.25Nm				

Ordering information

U_C	150	275	320	385	440
Ordering code PROTEC BS 35/xxx	502.320	502.321	502.322	502.306	502.307
Ordering code PROTEC BSR 35/xxx (with remote contacts)	502.323	502.324	502.325	502.308	502.309

PROTEC BS(R)



- Category IEC / EN / VDE: Class I, II / Type 1, 2 / B, C
- Location of use: Main distribution boards
- Network systems: TN-S, TN-C, IT
- Protection modes: L/N - PE, L- PEN
- Protective element: High energy MOV
- Surge discharge rating: $I_{imp} = 50kA$
- MOV max. withstand capability 1 x 8/20: 150kA
- Housing: Compact design
- Complies with: IEC/EN 61643-11



Technical data

Type	PROTEC BS(R) 50/xxx					
	150	275	320	385	440	
Electrical characteristics						
Max. continuous operating voltage (AC/DC)	U_C	150/200V	275/350V	320/420V	385/500V	440/580V
Nominal discharge current (8/20)	I_n	25kA				
Max. discharge current (8/20)	I_{max}	100kA				
Impulse current (10/350)	I_{imp}	50kA				
Specific energy	W/R	625kJ/Ω				
Charge	Q	17.5As				
Protection level	U_p	< 0.6kV	< 1.2kV	< 1.2kV	< 1.6kV	< 1.9kV
Residual voltage at I_{imp}	U_{res}	< 0.7kV	< 1.2kV	< 1.2kV	< 1.5kV	< 1.8kV
Residual voltage at 5kA (8/20)	U_{res}	< 0.5kV	< 0.9kV	< 0.9kV	< 1.3kV	< 1.6kV
Follow current	I_{fi}	NO				
Response time	t_A	< 25ns				
Thermal protection		YES				
Back-up fuse (if mains > 250A)		250A gL				
Short-circuit withstand current	I_{SCCR}	25kA/50Hz				
Mechanical characteristics						
Temperature range		- 40°C+ 80°C				
Terminal screw torque		max. 3.0Nm				
Terminal cross section		35mm ² (solid)/25mm ² (stranded)				
Mounting		35mm DIN rail, EN 60715				
Degree of protection		IP 20				
Housing material		Thermoplastic; extinguishing degree UL 94 V-0				
Indication of disconnector operation		red flag				
Remote contacts (RC)		YES				
Contact ratings		AC: 250V/0.5A; 125V/3A				
Terminal cross section		max. 1.5mm ²				
Remote terminal torque		0.25Nm				

Ordering information

U_C	150	275	320	385	440
Ordering code PROTEC BS 50/xxx	502.314	502.315	502.316	502.296	502.297
Ordering code PROTEC BSR 50/xxx (with remote contacts)	502.317	502.318	502.319	502.298	502.299

Dimensions, Internal configuration, Weight and Packaging

PROTEC BS(R) 35/xxx

Dimensions

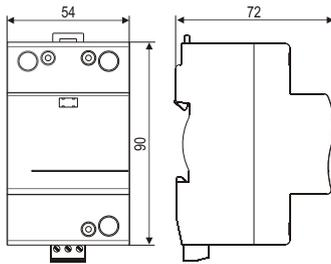
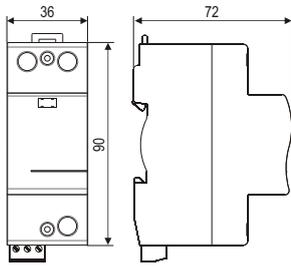

Internal configuration

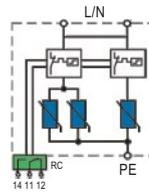
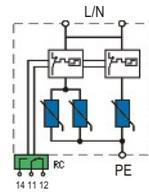

PROTEC BS 35/xxx	150	275	320
Dimensions DIN 43880	2TE		
Weight per unit	254g	336g	336g

PROTEC BSR 35/xxx	150	275	320
Dimensions DIN 43880	2TE		
Weight per unit	259g	341g	341g
Packaging dimensions (single unit)	109 x 76.5 x 41.5mm		
Min. packaging quantity	7 pcs.		

PROTEC BS 35/xxx	385	440
Dimensions DIN 43880	3TE	
Weight per unit	385g	415g

PROTEC BSR 35/xxx	385	440
Dimensions DIN 43880	3TE	
Weight per unit	390g	420g
Packaging dimensions (single unit)	109 x 76.5 x 60mm	
Min. packaging quantity	5 pcs.	

PROTEC BS(R) 50/xxx

Dimensions

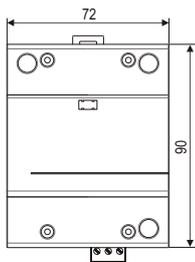
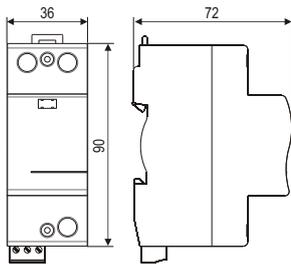

Internal configuration

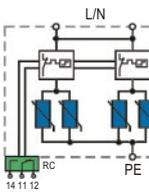
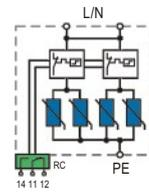

PROTEC BS 50/xxx	150	275	320
Dimensions DIN 43880	2TE		
Weight per unit	266g	374g	374g

PROTEC BSR 50/xxx	150	275	320
Dimensions DIN 43880	2TE		
Weight per unit	271g	379g	379g
Packaging dimensions (single unit)	109 x 76.5 x 41.5mm		
Min. packaging quantity	7 pcs.		

PROTEC BS 50/xxx	385	440
Dimensions DIN 43880	4TE	
Weight per unit	438g	458g

PROTEC BSR 50/xxx	385	440
Dimensions DIN 43880	4TE	
Weight per unit	443g	463g
Packaging dimensions (single unit)	109 x 76.5 x 78mm	
Min. packaging quantity	3 pcs.	

PROBLOC BS(R) (1+1)



- **Category IEC / EN / VDE:** Class I, II / Type 1, 2 / B, C
- **Location of use:** Main distribution boards
- **Network system:** TT, TN-S
- **Protection modes:** L-N, N-PE
- **Protective element:** High energy MOV and GDT
- **Surge discharge rating:** $I_{imp} = 50kA/100kA (L-N/N-PE)$
- **MOV max. withstand capability 1 x 8/20:** 150kA per pole
- **Housing:** Compact design
- **Complies with:** IEC/EN 61643-11

Technical data

Type		PROBLOC BS(R) 100/xxx (1+1)				
		150	275	320	385	440
Electrical characteristics						
Max. continuous operating voltage (AC/DC)	U_C (L-N)	150/200V	275/350V	320/420V	385/500V	440/580V
	U_C (N-PE)	255V				
Nominal discharge current (8/20)	I_n (L-N/N-PE)	25kA/100kA				
Max. discharge current (8/20)	I_{max} (L-N/N-PE)	100kA/100kA				
Impulse current (10/350)	I_{imp} (L-N/N-PE)	50kA/100kA				
Specific energy	W/R (L-N/N-PE)	625kJ/Ω/2.5MJ/Ω				
Charge	Q (L-N/N-PE)	25As/50As				
Protection level	U_p (L-N)	< 0.7kV	< 1.4kV	< 1.4kV	< 1.8kV	< 2.1kV
	U_p (N-PE)	< 1.75kV				
Residual voltage at I_{imp}	U_{res} (L-N)	< 0.7kV	< 1.2kV	< 1.2kV	< 1.5kV	< 1.8kV
Residual voltage at 5kA (8/20)	U_{res}	< 0.5kV	< 0.9kV	< 0.9kV	< 1.3kV	< 1.5kV
Follow current	I_{fj} (N-PE)	100ARMS				
Response time	t_A (L-N/N-PE)	< 25ns/100ns				
Thermal protection	(L-N)	YES				
Back-up fuse (if mains > 250A)	(L-N)	250A gL				
Short-circuit withstand current	I_{scCR} (L-N)	25kA/50Hz				
Mechanical characteristics						
Temperature range		- 40°C ... + 80°C				
Terminal screw torque		max. 3.0Nm				
Terminal cross section		35mm ² (solid)/25mm ² (stranded)				
Mounting		35mm DIN rail, EN 60715				
Degree of protection		IP 20				
Housing material		Thermoplastic; extinguishing degree UL 94 V-0				
Indication of disconnecter operation		red flag				
Remote contacts (RC)		YES				
Contact ratings		AC: 250V/0.5A; 125V/3A				
Terminal cross section		max. 1.5mm ²				
Remote terminal torque		0.25Nm				

Ordering information

U_C	150	275	320	385	440
Ordering code PROBLOC BS 100/xxx (1+1)	504.512	504.513	504.514	504.396	504.397
Ordering code PROBLOC BSR 100/xxx (1+1) (with remote contacts)	504.515	504.516	504.517	504.398	504.399

Dimensions, Internal configuration, Weight and Packaging
Network connections

PROBLOC BS(R) 100/xxx (1+1)

Dimensions

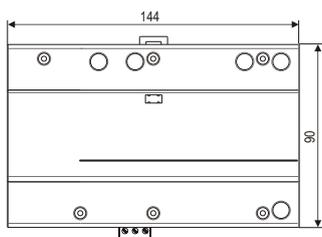
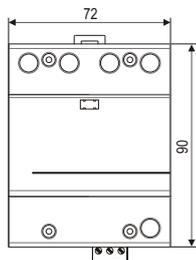

Internal configuration

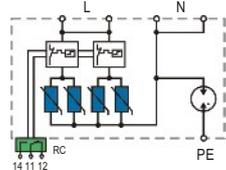
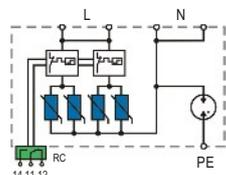

PROBLOC BS 100/xxx (1+1)	150	275	320
Dimensions DIN 43880	4TE		
Weight per unit	430g	540g	540g

PROBLOC BSR 100/xxx (1+1)	150	275	320
Dimensions DIN 43880	4TE		
Weight per unit	435g	545g	545g
Packaging dimensions (single unit)	109 x 76.5 x 78mm		
Min. packaging quantity	3 pcs.		

PROBLOC BS 100/xxx (1+1)	385	440
Dimensions DIN 43880	8TE	
Weight per unit	654g	698g

PROBLOC BSR 100/xxx (1+1)	385	440
Dimensions DIN 43880	8TE	
Weight per unit	559g	703g
Packaging dimensions (single unit)	109 x 76.5 x 148mm	
Min. packaging quantity	2 pcs.	

TT Network - Single-phase (T-connection)

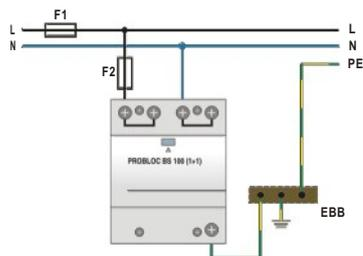

TT Network - Single-phase (V-connection)

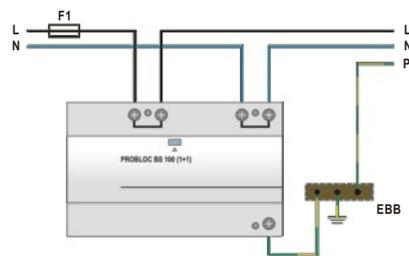

Back-up fuse



Class I, II Modular Single and Multi-pole SPD 12.5kA per pole



Category IEC / EN / VDE:

Location of use:

Protection modes:

Protective elements:

Surge discharge ratings:

Internal protection and safety:

Complies with:

Class I, II / Type 1, 2 / B, C

Main distribution boards

L/N-PE, L-PEN, L-N, N-PE

High energy MOV and GDT

$I_{imp} = 12.5kA$

Separate thermal disconnecter for each MOV

IEC/EN 61643-11

PROTEC B2S(R) Series:

PROTEC B2S(R) 12.5/xxx

PROTEC B2S(R) 25/xxx (2+0)

PROTEC B2S(R) 37.5/xxx (3+0)

PROTEC B2S(R) 50/xxx (4+0)

PROTEC B2S(R) 25/xxx (1+1)

PROTEC B2S(R) 50/xxx (3+1)

The PROTEC B2S(R) 12.5 kA per pole series of overvoltage surge protection devices has been developed to protect against partial and indirect lightning discharges. It is suited for power supply installations and intended to provide protection in zones 0_A - 2 per IEC 62305.

The plug-in module / base design facilitates replacement of a failed module *in situ* without the need to remove system wiring.

PROTEC B2S(R) series consists of a high performance paired varistors combination for each pole, equipped with a thermal disconnection mechanism.

PROTEC B2S(R) series complies with the IEC/EN 61643-11 standard and is applicable to the following connections: TN-S, TN-C, IT and TT.



PROTEC B2S(R)



- **Category IEC / EN / VDE:** Class I, II / Type 1, 2 / B, C
- **Location of use:** Main distribution boards
- **Network systems:** TN-S, TN-C, IT
- **Protection modes:** L/N - PE, L- PEN
- **Protective element:** High energy MOV
- **Surge discharge rating:** $I_{imp} = 12.5kA$
- **MOV max. withstand capability 1 x 8/20:** 100kA
- **Housing:** Modular design
- **Complies with:** IEC/EN 61643-11



Technical data

Type	PROTEC B2S(R) 12.5/xxx					
	150	275	320	385	440	
Electrical characteristics						
Max. continuous operating voltage (AC/DC)	U_C	150/200V	275/350V	320/420V	385/500V	440/580V
Nominal discharge current (8/20)	I_n	25kA				
Max. discharge current (8/20)	I_{max}	60kA				
Impulse current (10/350)	I_{imp}	12.5kA				
Specific energy	W/R	39kJ/Ω				
Charge	Q	6.25As				
Protection level	U_p	< 1.0kV	< 1.4kV	< 1.5kV	< 1.7kV	< 2.0kV
Residual voltage at I_{imp}	U_{res}	< 0.7kV	< 1.0kV	< 1.1kV	< 1.4kV	< 1.5kV
Residual voltage at 5kA (8/20)	U_{res}	< 0.6kV	< 0.9kV	< 1.0kV	< 1.3kV	< 1.4kV
Follow current	I_{fi}	NO				
Response time	t_A	< 25ns				
Thermal protection		YES				
Back-up fuse (if mains > 160A)		160A gL				
Short-circuit withstand current	I_{SCCR}	25kA/50Hz				
Mechanical characteristics						
Temperature range		- 40°C + 80°C				
Terminal screw torque		max. 3.0Nm				
Terminal cross section		35mm ² (solid)/25mm ² (stranded)				
Mounting		35mm DIN rail, EN 60715				
Degree of protection		IP 20				
Housing material		Thermoplastic; extinguishing degree UL 94 V-0				
Indication of disconnector operation		red flag				
Remote contacts (RC)		YES				
Contact ratings		AC: 250V/0.5A; 125V/3A				
Terminal cross section		max. 1.5mm ²				
Remote terminal torque		0.25Nm				

Ordering information

U_C	150	275	320	385	440
Ordering code PROTEC B2S 12.5/xxx	506.017	506.018	506.019	506.020	506.021
Ordering code PROTEC B2SR 12.5/xxx (with remote contacts)	506.022	506.023	506.024	506.025	506.026
Ordering code Module PROTEC B2S(R) 12.5/xxx (with remote contacts)	506.001	506.002	506.003	506.004	506.005

PROTEC B2S(R) Series



- Category IEC / EN / VDE: Class I, II / Type 1, 2 / B, C
- Location of use: Main distribution boards
- Network systems: TN-S, TN-C, IT
- Protection modes: L/N - PE, L-PEN
- Protective element: High energy MOV
- Surge discharge rating: $I_{imp} = 12.5kA$
- MOV max. withstand capability 1 x 8/20: 100kA per pole
- Housing: Modular design
- Complies with: IEC/EN 61643-11



Technical data

Type	PROTEC B2S(R) yy/xxx (2+0), (3+0), (4+0)					
	150	275	320	385	440	
Electrical characteristics						
Max. continuous operating voltage (AC/DC)	U_C	150/200V	275/350V	320/420V	385/500V	440/580V
Nominal discharge current (8/20)	I_n	25kA per pole				
Max. discharge current (8/20)	I_{max}	60kA per pole				
Impulse current (10/350)	I_{imp}	12.5kA per pole				
Specific energy	W/R	39kJ/Ω				
Charge	Q	6.25As				
Protection level	U_p	< 1.0kV	< 1.4kV	< 1.5kV	< 1.7kV	< 2.0kV
Residual voltage at I_{imp}	U_{res}	< 0.7kV	< 1.0kV	< 1.1kV	< 1.4kV	< 1.5kV
Residual voltage at 5kA (8/20)	U_{res}	< 0.6kV	< 0.9kV	< 1.0kV	< 1.3kV	< 1.4kV
Follow current	I_{fi}	NO				
Response time	t_A	< 25ns				
Thermal protection		YES				
Back-up fuse (if mains > 160A)		160A gL				
Short-circuit withstand current	I_{SCCR}	25kA/50Hz				
Mechanical characteristics						
Temperature range		- 40°C ... + 80°C				
Terminal screw torque		max. 3.0Nm				
Terminal cross section		35mm ² (solid)/25mm ² (stranded)				
Mounting		35mm DIN rail, EN 60715				
Degree of protection		IP 20				
Housing material		Thermoplastic; extinguishing degree UL 94 V-0				
Indication of disconnector operation		red flag				
Remote contacts (RC)		YES				
Contact ratings		AC: 250V/0.5A; 125V/3A				
Terminal cross section		max. 1.5mm ²				
Remote terminal torque		0.25Nm				

Ordering information

U_C	150	275	320	385	440
Ordering code PROTEC B2S 25/xxx (2+0)	506.027	506.028	506.029	506.030	506.031
Ordering code PROTEC B2SR 25/xxx (2+0) (with remote contacts)	506.032	506.033	506.034	506.035	506.036
Ordering code PROTEC B2S 37.5/xxx (3+0)	506.047	506.048	506.049	506.050	506.051
Ordering code PROTEC B2SR 37.5/xxx (3+0) (with remote contacts)	506.052	506.053	506.054	506.055	506.056
Ordering code PROTEC B2S 50/xxx (4+0)	506.057	506.058	506.059	506.060	506.061
Ordering code PROTEC B2SR 50/xxx (4+0) (with remote contacts)	506.062	506.063	506.064	506.065	506.066
Ordering code Module PROTEC B2S(R) 12.5/xxx	506.001	506.002	506.003	506.004	506.005

Dimensions, Internal configuration, Weight and Packaging

PROTEC B2S(R) 12.5

Dimensions

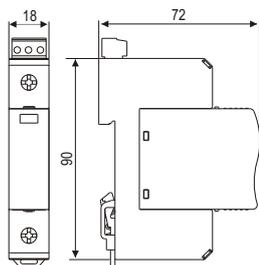

Internal configuration

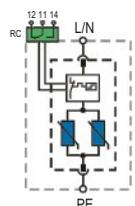

PROTEC B2S 12.5/xxx	150	275	320	385	440
Dimensions DIN 43880	1TE				
Weight per unit	124g	150g	150g	143g	146g
PROTEC B2SR 12.5/xxx	150	275	320	385	440
Dimensions DIN 43880	1TE				
Weight per unit	129g	155g	155g	148g	151g
Packaging dimensions (single unit)	108 x 74 x 24mm				
Min. packaging quantity	12 pcs.				

PROTEC B2S(R) 25/xxx (2+0)

Dimensions

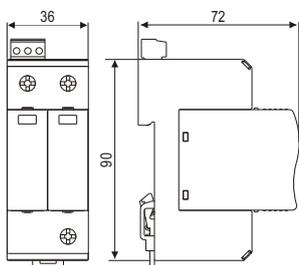

Internal configuration

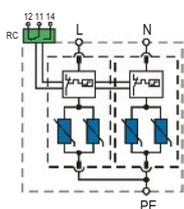

PROTEC B2S 25/xxx (2+0)	150	275	320	385	440
Dimensions DIN 43880	2TE				
Weight per unit	198g	251g	251g	267g	283g
PROTEC B2SR 25/xxx (2+0)	150	275	320	385	440
Dimensions DIN 43880	2TE				
Weight per unit	203g	256g	256g	272g	288g
Packaging dimensions (single unit)	109 x 76.5 x 41.5mm				
Min. packaging quantity	7 pcs.				

PROTEC B2S(R) 37.5/xxx (3+0)

Dimensions

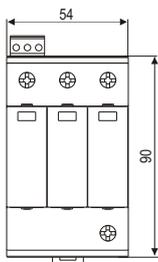

Internal configuration

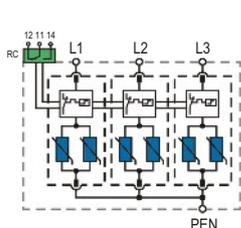

PROTEC B2S 37.5/xxx (3+0)	150	275	320	385	440
Dimensions DIN 43880	3TE				
Weight per unit	300g	382g	382g	394g	432g
PROTEC B2SR 37.5/xxx (3+0)	150	275	320	385	440
Dimensions DIN 43880	3TE				
Weight per unit	305g	387g	387g	399g	437g
Packaging dimensions (single unit)	109 x 76.5 x 60mm				
Min. packaging quantity	5 pcs.				

PROTEC B2S(R) 50/xxx (4+0)

Dimensions

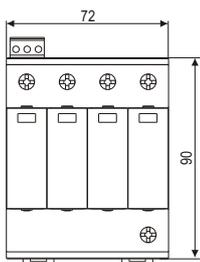

Internal configuration

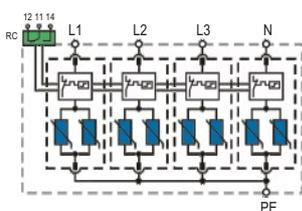

PROTEC B2S 50/xxx (4+0)	150	275	320	385	440
Dimensions DIN 43880	4TE				
Weight per unit	366g	462g	462g	494g	526g
PROTEC B2SR 50/xxx (4+0)	150	275	320	385	440
Dimensions DIN 43880	4TE				
Weight per unit	371g	467g	467g	499g	531g
Packaging dimensions (single unit)	109 x 76.5 x 78mm				
Min. packaging quantity	3 pcs.				

PROTEC B2S(R) Series



- **Category IEC / EN / VDE:** Class I, II / Type 1, 2 / B, C
- **Location of use:** Main distribution boards
- **Network system:** TT, TN-S
- **Protection modes:** L-N, N-PE
- **Protective element:** High energy MOV and GDT
- **Surge discharge rating:** $I_{imp} = 12.5kA/50kA (L-N/N-PE)$
- **MOV max. withstand capability 1 x 8/20:** 100kA per pole
- **Housing:** Modular design
- **Complies with:** IEC/EN 61643-11



Technical data

Type		150	275	320	385	440
Electrical characteristics						
Max. continuous operating voltage (AC/DC)	U_c (L-N)	150/200V	275/350V	320/420V	385/500V	440/580V
	U_c (N-PE)	255V				
Nominal discharge current (8/20)	I_n (L-N/N-PE)	25kA/30kA				
Max. discharge current (8/20)	I_{max} (L-N/N-PE)	60kA/50kA				
Impulse current (10/350)	I_{imp} (L-N/N-PE)	12.5kA/50kA				
Specific energy	W/R (L-N/N-PE)	39kJ/Ω/2.5MJ/Ω				
Charge	Q (L-N/N-PE)	6.25As/50As				
Protection level	U_p (L-N)	< 1.0kV	< 1.4kV	< 1.5kV	< 1.7kV	< 2.0kV
	U_p (N-PE)	< 1.7kV				
Residual voltage at I_{imp}	U_{res} (L-N)	< 0.7kV	< 1.0kV	< 1.1kV	< 1.4kV	< 1.5kV
Residual voltage at 5kA (8/20)	U_{res} (L-N)	< 0.6kV	< 0.9kV	< 1.0kV	< 1.3kV	< 1.4kV
Follow current	I_{fi} (N-PE)	100ARMS				
Response time	t_A (L-N/N-PE)	< 25ns/100ns				
Thermal protection	(L-N)	YES				
Back-up fuse (if mains > 160A)	(L-N)	160A gL				
Short-circuit withstand current	I_{SCCR} (L-N)	25kA/50Hz				
Mechanical characteristics						
Temperature range		- 40°C ... + 80°C				
Terminal screw torque		max. 3.0Nm				
Terminal cross section		35mm ² (solid)/25mm ² (stranded)				
Mounting		35mm DIN rail, EN 60715				
Degree of protection		IP 20				
Housing material		Thermoplastic; extinguishing degree UL 94 V-0				
Indication of disconnector operation		red flag				
Remote contacts (RC)		YES				
Contact ratings		AC: 250V/0.5A; 125V/3A				
Terminal cross section		max. 1.5mm ²				
Remote terminal torque		0.25Nm				

Ordering information

U_c	150	275	320	385	440
Ordering code PROTEC B2S 25/xxx (1+1)	506.037	506.038	506.039	506.040	506.041
Ordering code PROTEC B2SR 25/xxx (1+1) (with remote contacts)	506.042	506.043	506.044	506.045	506.046
Ordering code PROTEC B2S 50/xxx (3+1)	506.067	506.068	506.069	506.070	506.071
Ordering code PROTEC B2SR 50/xxx (3+1) (with remote contacts)	506.072	506.073	506.074	506.075	506.076
Ordering code Module PROTEC B2S(R) 12.5/xxx	506.001	506.002	506.003	506.004	506.005
Ordering code Module PROTUBE B2S 50/255			506.006		

Dimensions, Connection diagrams, Weight and Packaging

PROTEC B2S 25/xxx (1+1)

Dimensions

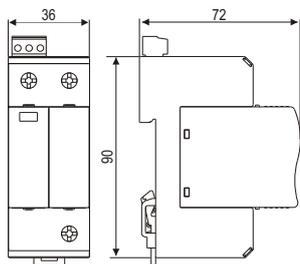

Internal configuration

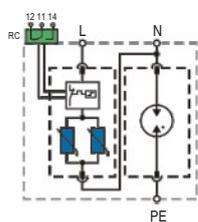

PROTEC B2S 25/xxx (1+1)	150	275	320	385	440
Dimensions DIN 43880	2TE				
Weight per unit	270g	310g	342g	366g	370g
PROTEC B2SR 25/xxx (1+1)	150	275	320	385	440
Dimensions DIN 43880	2TE				
Weight per unit	275g	315g	347g	371g	375g
Packaging dimensions (single unit)	109 x 76.5 x 41.5mm				
Min. packaging quantity	7 pcs.				

PROTEC B2S(R) 50/xxx (3+1)

Dimensions

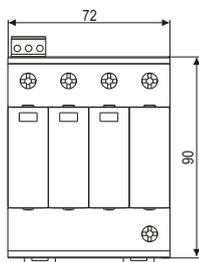

Internal configuration

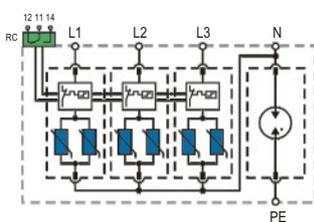

PROTEC B2S 50/xxx (3+1)	150	275	320	385	440
Dimensions DIN 43880	4TE				
Weight per unit	498g	578g	642g	690g	698g
PROTEC B2SR 50/xxx (3+1)	150	275	320	385	440
Dimensions DIN 43880	4TE				
Weight per unit	503g	583g	647g	695g	703g
Packaging dimensions (single unit)	109 x 76.5 x 78mm				
Min. packaging quantity	3 pcs.				

Module PROTEC B2S(R) 12.5/xxx

Dimensions

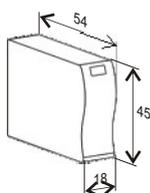

Internal configuration

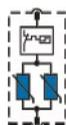

Module PROTEC B2S(R) 12.5/xxx	150	275	320	385	440
Weight per unit	78g	88g	102g	116g	128g
Packaging dimensions	219 x 62 x 47mm				
Min. packaging quantity	12 pcs.				

Module PROTUBE B2S 50

Dimensions

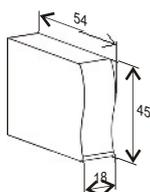

Internal configuration



Module PROTUBE B2S 50	255
Weight per unit	70g
Packaging dimensions	219 x 62 x 47mm
Min. packaging quantity	12 pcs.

PROTEC B2S(R) Series

Network connections

TN-S Network (Single-phase)

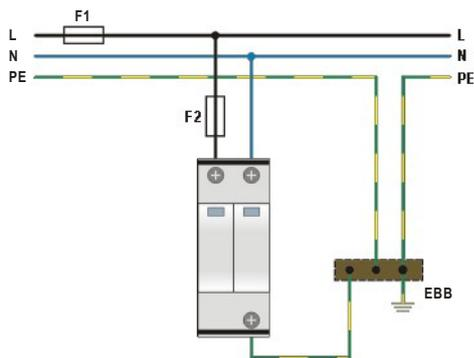

TN-S Network (Three-phase)

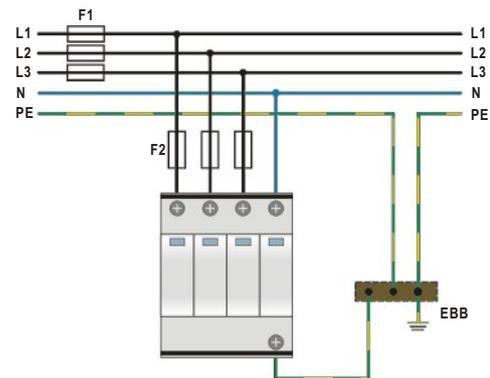

TN-C Network (Three-phase)

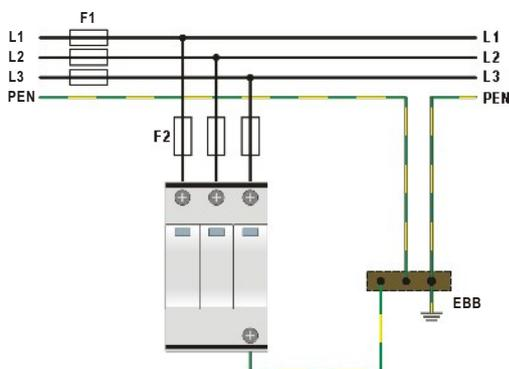

TT Network (Single-phase)

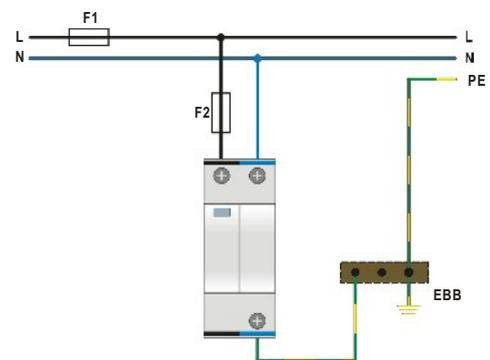

TT Network (Three-phase)

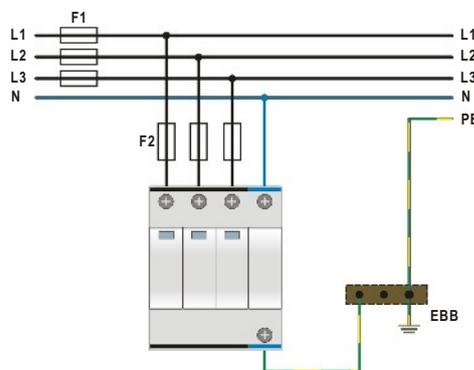

IT Network (Three-phase)

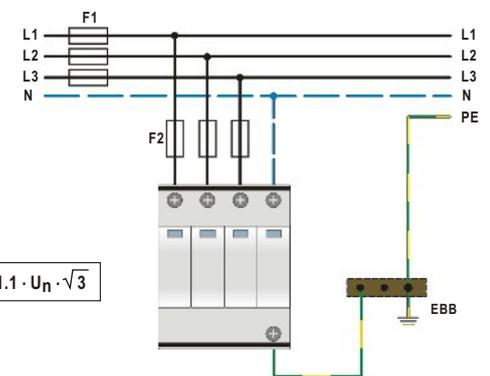

$$U_c \geq 1.1 \cdot U_n \cdot \sqrt{3}$$

Back-up fuse

- F1 > 160 A gL → F2 = 160 A gL
- F1 ≤ 160 A gL → F2

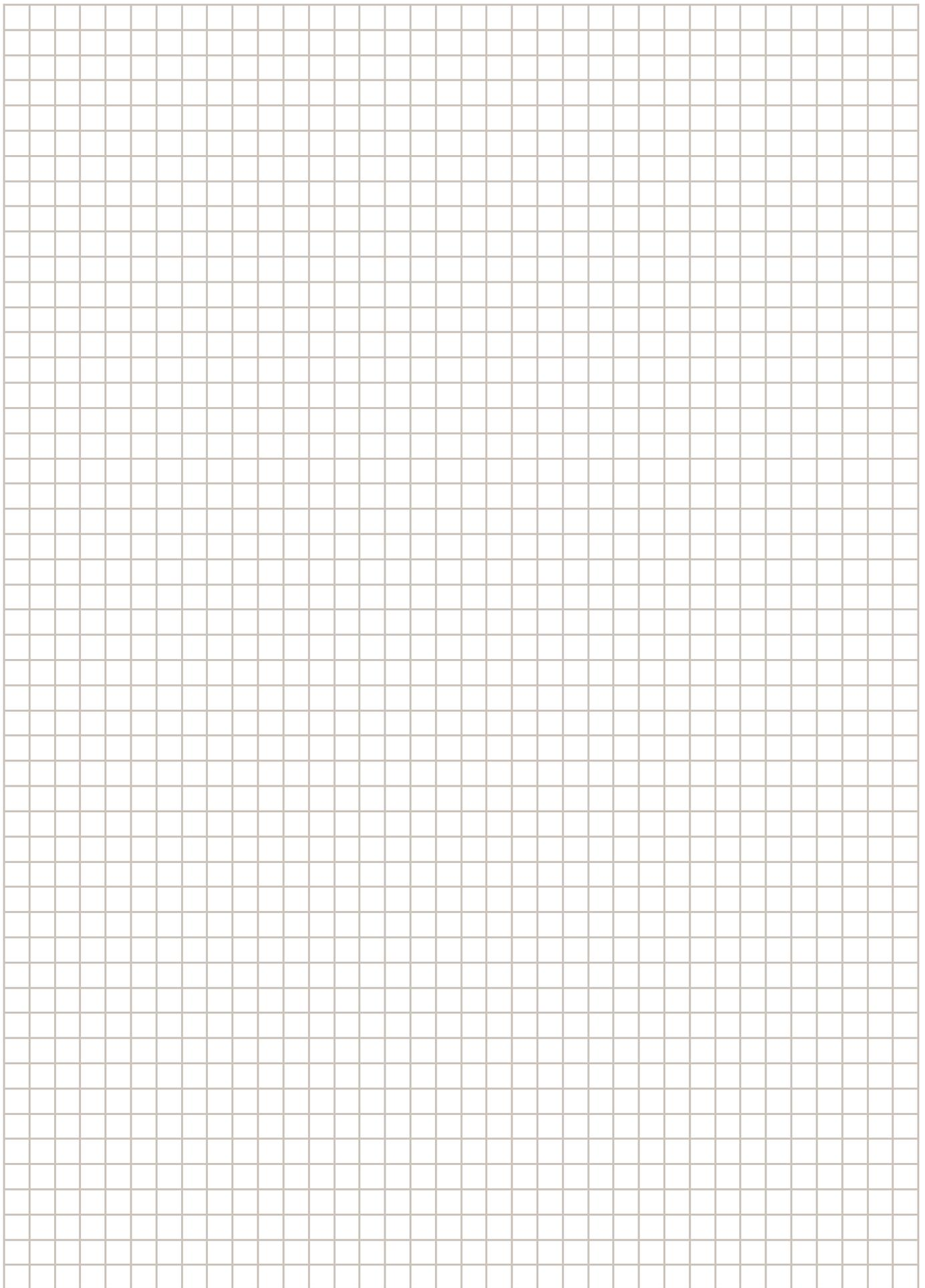

Class II Modular Single and Multi-pole SPD 40kA per pole



Category IEC / EN / VDE:	Class II / Type 2 / C
Location of use:	Sub-distribution boards
Protection modes:	L/N-PE, L-PEN, L-N, N-PE
Protective elements:	MOV and GDT
Surge discharge ratings:	I_{max} up to 40kA
Safety:	TOV withstand for unlimited time
Internal protection:	Separate thermal disconnecter for each MOV
Complies with:	IEC/EN 61643-11

The new SAFETEC series of SPDs :

- Are highly reliable - controlled disconnection, arc-quenching
- Are safer - controlled behaviour even when surge ratings are exceeded
- Have longer life - protection against ageing
- Have up to 20 years warranty

SAFETEC C(R) Series:

SAFETEC C(R) 40
SAFETUBE C 40
SAFETEC C(R) 80 (2+0)
SAFETEC C(R) 120 (3+0)
SAFETEC C(R) 160 (4+0)
SAFETEC C(R) 80 (1+1)
SAFETEC C(R) 160 (3+1)

The modular SAFETEC C(R) series is suitable for all type of connections.

Patented TC* technology prevents catastrophic failures in case of TOV (temporary overvoltages).

All in one technology is a protection from overvoltages surges and transients. It has been developed to protect against partial direct and indirect lightning discharges and are intended to provide protection in zones O_B - 2 per IEC 62305.



*TC - Thermal control function

SAFETEC C(R)



- **Category IEC / EN / VDE:** Class II / Type 2 / C
- **Location of use:** Sub-distribution boards
- **Network systems:** TN-S, TN-C, IT, TT (only L-N)
- **Protection modes:** L/N - PE, L- PEN
- **Protective element:** MOV and GDT
- **Surge discharge rating:** I_{max} up to 40kA
- **Safety:** TOV withstand for unlimited time
- **Housing:** Modular design
- **Complies with:** IEC/EN 61643-11



Technical data

Type		75	150	SAFETEC C(R) yy/xxx			
				275	385	440	750
Electrical characteristics							
Max. continuous operating voltage (AC/DC)	U_C	75/100V	150/200V	275/350V	385/500V	440/580V	750/1000V
Nominal discharge current (8/20)	I_n	10kA			20kA		12.5kA
Max. discharge current (8/20)	I_{max}	20kA			40kA		25kA
Protection level	U_p	< 0.8kV	< 1.1kV	< 1.5kV	< 2.2kV	< 2.3kV	< 2.8kV
Residual voltage at 5kA (8/20)	U_{res}	< 0.6kV	< 0.7kV	< 1.1kV	< 1.3kV	< 1.6kV	< 2.2kV
Follow current	I_{fi}	NO					
Response time	t_A	< 25ns					
Thermal protection		YES					
Back-up fuse (if mains > 125A)		125A gL					
TOV withstand for unlimited time up to	U_T	110V	230V	440V	560V	690V	1100V
Mechanical characteristics							
Terminal screw torque		max. 3.0Nm					
Temperature range		- 40°C + 80°C					
Terminal cross section		35mm ² (solid) / 25mm ² (stranded)					
Mounting		35mm DIN rail, EN 60715					
Degree of protection		IP 20					
Housing material		thermoplastic; extinguishing degree UL 94 V-0					
Indication of disconnector operation		red flag					
Remote contacts (RC)		YES					
Contact ratings		AC: 250V/0.5A; 125V/3A					
Terminal cross section		max. 1.5mm ²					
Remote terminal torque		0.25Nm					

Ordering information

U_C	75	150	275	385	440	750
Ordering code SAFETEC C 20/75	516.612					
Ordering code SAFETEC CR 20/75 (with remote contacts)	516.613					
Ordering code SAFETEC C 40/xxx		516.001	516.003	516.614	516.005	
Ordering code SAFETEC CR 40/xxx (with remote contacts)		516.002	516.004	516.615	516.006	
Ordering code SAFETEC C 25/750						516.616
Ordering code SAFETEC CR 25/750 (with remote contacts)						516.617
Ordering code Module SAFETEC C(R) 20/75	516.648					
Ordering code Module SAFETEC C(R) 40/xxx		516.037	516.038	516.649	516.039	
Ordering code Module SAFETEC C(R) 25/750						516.650

SAFETUBE C 40



- **Category IEC / EN / VDE:** Class II / Type 2 / C
- **Location of use:** Sub-distribution boards
- **Network system:** TT
- **Protection modes:** N - PE
- **Protective element:** GDT
- **Surge discharge rating:** $I_{max} = 40kA$
- **Housing:** Modular design
- **Complies with:** IEC/EN 61643-11



Technical data

Type		SAFETUBE C 40/255
Electrical characteristics		
Max. continuous operating voltage (AC)	U_c	255V
Nominal discharge current (8/20)	I_n	20kA
Max. discharge current (8/20)	I_{max}	40kA
Protection level	U_p	< 1.5kV
Follow current	I_{fi}	100ARMS
Response time	t_A	25ns
Mechanical characteristics		
Terminal screw torque		max. 3.0Nm
Temperature range		- 40°C + 80°C
Terminal cross section		35mm ² (solid) / 25mm ² (stranded)
Mounting		35mm DIN rail, EN 60715
Degree of protection		IP 20
Housing material		Thermoplastic; extinguishing degree UL 94 V-0

Ordering information

I_{max}	40
Ordering code SAFETUBE C 40/255	516.417
Ordering code Module SAFETUBE C 40/255	516.115

Dimensions, Internal configuration, Weight and Packaging

SAFETEC C(R)

Dimensions

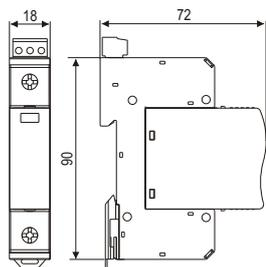

Internal configuration

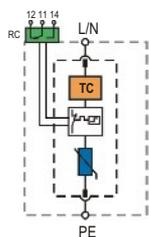

SAFETEC C 20/75	75			
Weight per unit	125g			
SAFETEC C 40/xxx	150	275	385	440
Weight per unit	140g	140g	148g	150g
SAFETEC C 25/750	750			
Weight per unit	156g			
SAFETEC CR 20/75	75			
Weight per unit	130g			
SAFETEC CR 40/xxx	150	275	385	440
Weight per unit	148g	148g	156g	158g
SAFETEC CR 25/750	750			
Weight per unit	164g			
Dimensions DIN 43880	1TE			
Packaging dimensions (single unit)	108 x 74 x 24mm			
Min. packaging quantity	12 pcs.			

Module SAFETEC C(R)

Dimensions

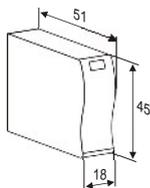

Internal configuration

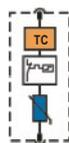

Module SAFETEC C(R) 20/75	75			
Weight per unit	58g			
Module SAFETEC C(R) 40/xxx	150	275	385	440
Weight per unit	62g	66g	72g	74g
Module SAFETEC C(R) 25/750	750			
Weight per unit	78g			
Packaging dimensions	219 x 62 x 47mm			
Min. packaging quantity	12 pcs.			

SAFETUBE C 40/255

Dimensions

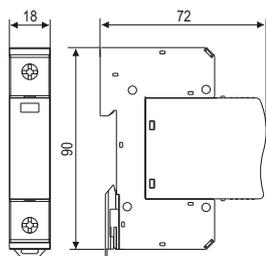

Internal configuration

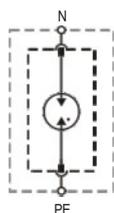

SAFETUBE C 40/255	255			
Dimensions DIN 43880	1TE			
Weight per unit	118g			
Packaging dimensions (single unit)	108 x 74 x 24mm			
Min. packaging quantity	12 pcs.			

Module SAFETUBE C 40/255

Dimensions

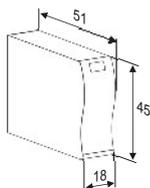

Internal configuration



Module SAFETUBE C 40/255	255			
Weight per unit	34g			
Packaging dimensions	219 x 62 x 47mm			
Min. packaging quantity	12 pcs.			

SAFETEC C(R) Series



- **Category IEC / EN / VDE:** Class II / Type 2 / C
- **Location of use:** Sub-distribution boards
- **Network systems:** TN-S, TN-C, IT
- **Protection modes:** L/N - PE, L - PEN
- **Protective element:** MOV and GDT
- **Surge discharge rating:** I_{max} up to 40kA
- **Safety:** TOV withstand for unlimited time
- **Housing:** Modular design
- **Complies with:** IEC/EN 61643-11



Technical data

Type	SAFETEC C(R) yyy/xxx (2+0), (3+0), (4+0)						
	75	150	275	385	440	750	
Electrical characteristics							
Max. continuous operating voltage (AC/DC)	U_C	75/100V	150/200V	275/350V	385/500V	440/580V	750/1000V
Nominal discharge current (8/20)	I_n	10kA per pole			20kA per pole		12.5kA per pole
Max. discharge current (8/20)	I_{max}	20kA per pole			40kA per pole		25kA per pole
Protection level	U_p	< 0.8kV	< 1.1kV	< 1.5kV	< 2.2kV	< 2.3kV	< 2.8kV
Residual voltage at 5kA (8/20)	U_{res}	< 0.6kV	< 0.7kV	< 1.1kV	< 1.3kV	< 1.6kV	< 2.2kV
Follow current	I_{fi}	NO					
Response time	t_A	< 25ns					
Thermal protection		YES					
Back-up fuse (if mains > 125A)		125A gL					
TOV withstand for unlimited time up to	U_T	110V	230V	440V	560V	690V	1100V
Mechanical characteristics							
Terminal screw torque		max. 3.0Nm					
Temperature range		- 40°C + 80°C					
Terminal cross section		35mm ² (solid) / 25mm ² (stranded)					
Mounting		35mm DIN rail, EN 60715					
Degree of protection		IP 20					
Housing material		thermoplastic; extinguishing degree UL 94 V-0					
Indication of disconnecter operation		red flag					
Remote contacts (RC)		YES					
Contact ratings		AC: 250V/0.5A; 125V/3A					
Terminal cross section		max. 1.5mm ²					
Remote terminal torque		0.25Nm					

Ordering information

U_C	75	150	275	385	440	750
Ordering code SAFETEC C 40/75 (2+0)	516.618					
Ordering code SAFETEC CR 40/75 (2+0) (with remote contacts)	516.619					
Ordering code SAFETEC C 80/xxx (2+0)		516.007	516.009	516.620	516.011	
Ordering code SAFETEC CR 80/xxx (2+0) (with remote contacts)		516.008	516.010	516.621	516.012	
Ordering code SAFETEC C 50/750 (2+0)						516.622
Ordering code SAFETEC CR 50/750 (2+0) (with remote contacts)						516.623
Ordering code SAFETEC C 60/75 (3+0)	516.630					
Ordering code SAFETEC CR 60/75 (3+0) (with remote contacts)	516.631					
Ordering code SAFETEC C 120/xxx (3+0)		516.019	516.021	516.632	516.023	
Ordering code SAFETEC CR 120/xxx (3+0) (with remote contacts)		516.020	516.022	516.633	516.024	
Ordering code SAFETEC C 75/750 (3+0)						516.634
Ordering code SAFETEC CR 75/750 (3+0) (with remote contacts)						516.635
Ordering code SAFETEC C 80/75 (4+0)	516.636					
Ordering code SAFETEC CR 80/75 (4+0) (with remote contacts)	516.637					
Ordering code SAFETEC C 160/xxx (4+0)		516.025	516.027	516.638	516.029	
Ordering code SAFETEC CR 160/xxx (4+0) (with remote contacts)		516.026	516.028	516.639	516.030	
Ordering code SAFETEC C 100/750 (4+0)						516.640
Ordering code SAFETEC CR 100/750 (4+0) (with remote contacts)						516.641

Dimensions, Internal configuration, Weight and Packaging

SAFETEC C(R) (2+0)

Dimensions

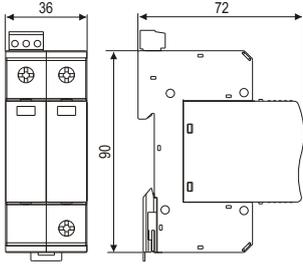

Internal configuration

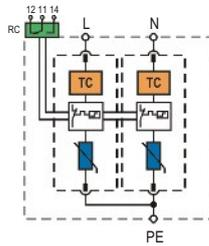

SAFETEC C 40/75 (2+0)	75			
Weight per unit	250g			
SAFETEC C 80/xxx (2+0)	150	275	385	440
Weight per unit	280g	281g	284g	286g
SAFETEC C 50/750 (2+0)	750			
Weight per unit	288g			
SAFETEC CR 40/75 (2+0)	75			
Weight per unit	260g			
SAFETEC CR 80/xxx (2+0)	150	275	385	440
Weight per unit	288g	289g	292g	294g
SAFETEC CR 50/750 (2+0)	750			
Weight per unit	296g			
Dimensions DIN 43880	2TE			
Packaging dimensions (single unit)	109 x 76.5 x 41.5mm			
Min. packaging quantity	7 pcs.			

SAFETEC C(R) (3+0)

Dimensions

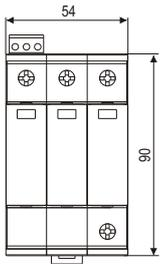

Internal configuration

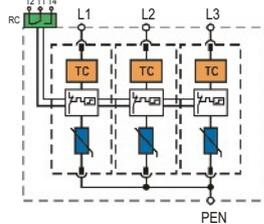

SAFETEC C 60/75 (3+0)	75			
Weight per unit	375g			
SAFETEC C 120/xxx (3+0)	150	275	385	440
Weight per unit	420g	422g	448g	450g
SAFETEC C 75/750 (3+0)	750			
Weight per unit	468g			
SAFETEC CR 60/75 (3+0)	75			
Weight per unit	390g			
SAFETEC CR 120/xxx (3+0)	150	275	385	440
Weight per unit	428g	430g	456g	458g
SAFETEC CR 75/750 (3+0)	750			
Weight per unit	476g			
Dimensions DIN 43880	3TE			
Packaging dimensions (single unit)	109 x 76.5 x 60mm			
Min. packaging quantity	5 pcs.			

SAFETEC C(R) (4+0)

Dimensions

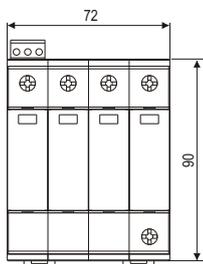

Internal configuration

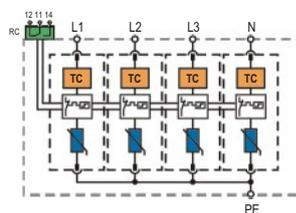

SAFETEC C 80/75 (4+0)	75			
Weight per unit	500g			
SAFETEC C 160/xxx (4+0)	150	275	385	440
Weight per unit	560g	562g	595g	598g
SAFETEC C 100/750x (4+0)	750			
Weight per unit	602g			
SAFETEC CR 80/75 (4+0)	75			
Weight per unit	520g			
SAFETEC CR 160/xxx (4+0)	150	275	385	440
Weight per unit	568g	570g	603g	606g
SAFETEC CR 100/750 (4+0)	750			
Weight per unit	610g			
Dimensions DIN 43880	4TE			
Packaging dimensions (single unit)	109 x 76.5 x 78mm			
Min. packaging quantity	3 pcs.			

SAFETEC C(R) Series



- **Category IEC / EN / VDE:** Class II / Type 2 / C
- **Location of use:** Sub-distribution boards
- **Network system:** TT
- **Protection modes:** L-N, N-PE
- **Protective element:** MOV and GDT
- **Surge discharge rating:** I_{max} up to 40kA
- **Safety:** TOV withstand for unlimited time
- **Housing:** Modular design
- **Complies with:** IEC/EN 61643-11



Technical data

Type	SAFETEC C(R) yyy/xxx (1+1), (3+1)						
	75	150	275	385	440	750	
Electrical characteristics							
Max. continuous operating voltage (AC/DC)	U_c (L-N)	75/100V	150/200V	275/350V	385/500V	440/580V	750/1000V
	U_c (N-PE)	255V					
Nominal discharge current (8/20)	I_n (L-N/N-PE)	10kA/20kA		20kA/20kA		12.5kA/20kA	
Max. discharge current (8/20)	I_{max} (L-N/N-PE)	20kA/40kA		40kA/40kA		25kA/40kA	
Protection level	U_p (L-N)	< 0.8kV	< 1.1kV	< 1.5kV	< 2.2kV	< 2.3kV	< 2.8kV
	U_p (N-PE)	< 1.5kV					
Residual voltage at 5kA (8/20)	U_{res} (L-N)	< 0.6kV	< 0.7kV	< 1.1kV	< 1.3kV	< 1.6kV	< 2.2kV
Follow current	I_{fi} (N-PE)	100A _{ARMS}					
Response time	t_A (L-N/N-PE)	< 25ns					
Thermal protection		YES					
Back-up fuse (if mains > 125A)		125A gL					
TOV withstand for unlimited time up to	U_T	110V	230V	440V	560V	690V	1100V
Mechanical characteristics							
Terminal screw torque		max. 3.0Nm					
Temperature range		- 40°C + 80°C					
Terminal cross section		35mm ² (solid) / 25mm ² (stranded)					
Mounting		35mm DIN rail, EN 60715					
Degree of protection		IP 20					
Housing material		thermoplastic; extinguishing degree UL 94 V-0					
Indication of disconnector operation		red flag					
Remote contacts (RC)		YES					
Contact ratings		AC: 250V/0.5A; 125V/3A					
Terminal cross section		max. 1.5mm ²					
Remote terminal torque		0.25Nm					

Ordering information

U_c	75	150	275	385	440	750
Ordering code SAFETEC C 40/75 (1+1)	516.624					
Ordering code SAFETEC CR 40/75 (1+1) (with remote contacts)	516.625					
Ordering code SAFETEC C 80/xxx (1+1)		516.013	516.015	516.626	516.017	
Ordering code SAFETEC CR 80/xxx (1+1) (with remote contacts)		516.014	516.016	516.627	516.018	
Ordering code SAFETEC C 50/750 (1+1)						516.628
Ordering code SAFETEC CR 50/750 (1+1) (with remote contacts)						516.629
Ordering code SAFETEC C 80/75 (3+1)	516.642					
Ordering code SAFETEC CR 80/75 (3+1) (with remote contacts)	516.643					
Ordering code SAFETEC C 160/xxx (3+1)		516.031	516.033	516.644	516.035	
Ordering code SAFETEC CR 160/xxx (3+1) (with remote contacts)		516.032	516.034	516.645	516.036	
Ordering code SAFETEC C 100/750 (3+1)						516.646
Ordering code SAFETEC CR 100/750 (3+1) (with remote contacts)						516.647
Ordering code Module SAFETEC C(R) 20/75	516.648					
Ordering code Module SAFETEC C(R) 40/xxx		516.037	516.038	516.649	516.039	
Ordering code Module SAFETEC C(R) 25/750						516.650
Ordering code Module SAFETUBE C 40/255				516.115		

Dimensions, Internal configuration, Weight and Packaging

SAFETEC C(R) (1+1)

Dimensions

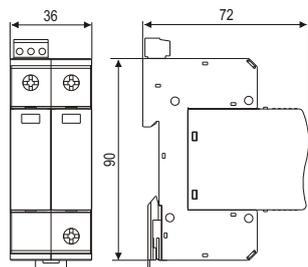

Internal configuration

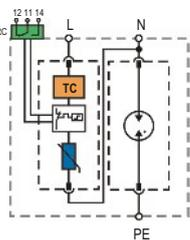

SAFETEC C 40/75 (1+1)	75			
Weight per unit	253g			
SAFETEC C 80/xxx (1+1)	150	275	385	440
Weight per unit	258g	258g	265g	268g
SAFETEC C 50/750 (1+1)	750			
Weight per unit	271g			
SAFETEC CR 40/75 (1+1)	75			
Weight per unit	261g			
SAFETEC CR 80/xxx (1+1)	150	275	385	440
Weight per unit	266g	266g	274g	276g
SAFETEC CR 50/750 (1+1)	750			
Weight per unit	279g			
Dimensions DIN 43880	2TE			
Packaging dimensions (single unit)	109 x 76,5 x 41,5mm			
Min. packaging quantity	7 pcs.			

SAFETEC C(R) (3+1)

Dimensions

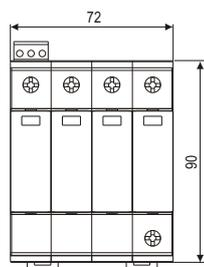

Internal configuration

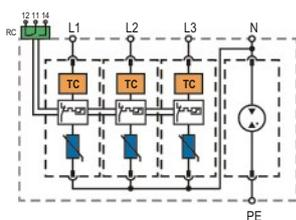

SAFETEC C 80/75 (3+1)	75			
Weight per unit	533g			
SAFETEC C 160/xxx (3+1)	150	275	385	440
Weight per unit	538g	540g	565g	568g
SAFETEC C 160/xxx (3+1)	750			
Weight per unit	571g			
SAFETEC CR 80/75 (3+1)	75			
Weight per unit	541g			
SAFETEC CR 160/xxx (3+1)	150	275	385	440
Weight per unit	546g	548g	574g	576g
SAFETEC CR 160/xxx (3+1)	750			
Weight per unit	579g			
Dimensions DIN 43880	4TE			
Packaging dimensions (single unit)	109 x 76,5 x 78mm			
Min. packaging quantity	3 pcs.			

Module SAFETEC C(R)

Dimensions

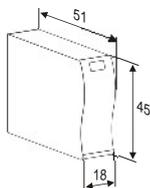

Internal configuration



Module SAFETEC C(R) 20/75	75			
Weight per unit	58g			
Module SAFETEC C(R) 40/xxx	150	275	385	440
Weight per unit	62g	66g	72g	74g
Module SAFETEC C(R) 25/750	750			
Weight per unit	78g			
Packaging dimensions	219 x 62 x 47mm			
Min. packaging quantity	12 pcs.			

Module SAFETUBE C 40/255

Dimensions

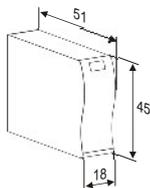

Internal configuration



Module SAFETUBE C 40/255	255			
Weight per unit	34g			
Packaging dimensions	219 x 62 x 47mm			
Min. packaging quantity	12 pcs.			

SAFETEC C(R) Series

Network connections

TN-S Network (Single-phase)

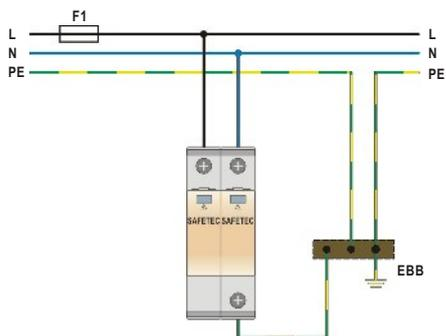

TT Network (Single-phase)

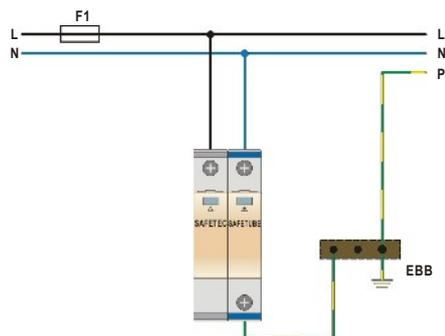

TN-C Network (Three-phase)

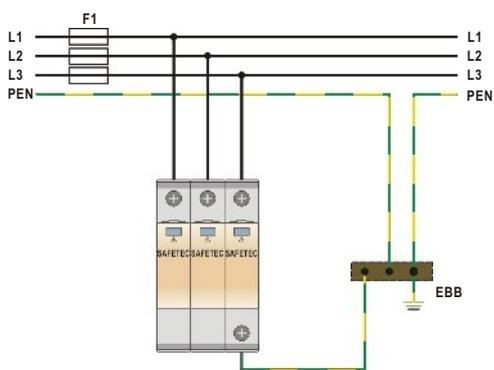

TN-S Network (Three-phase)

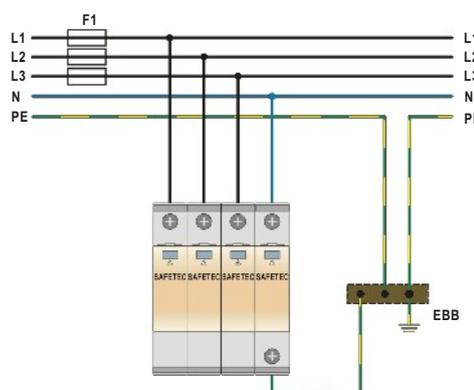

IT Network (Three-phase)

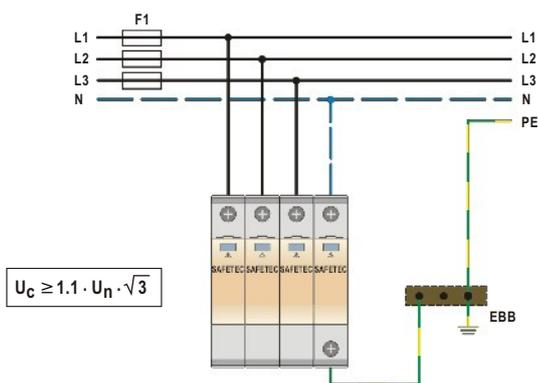

TT Network (Three-phase)

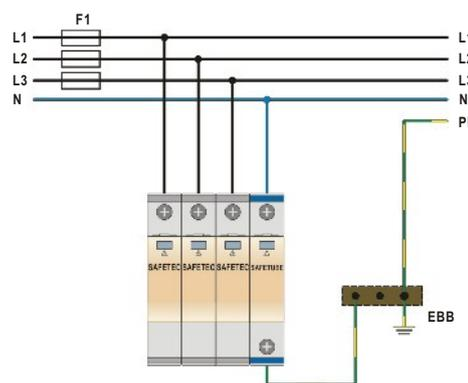

Back-up fuse

- F1 > 125 A gL → F2 = 125 A gL
- F1 ≤ 125 A gL → F2

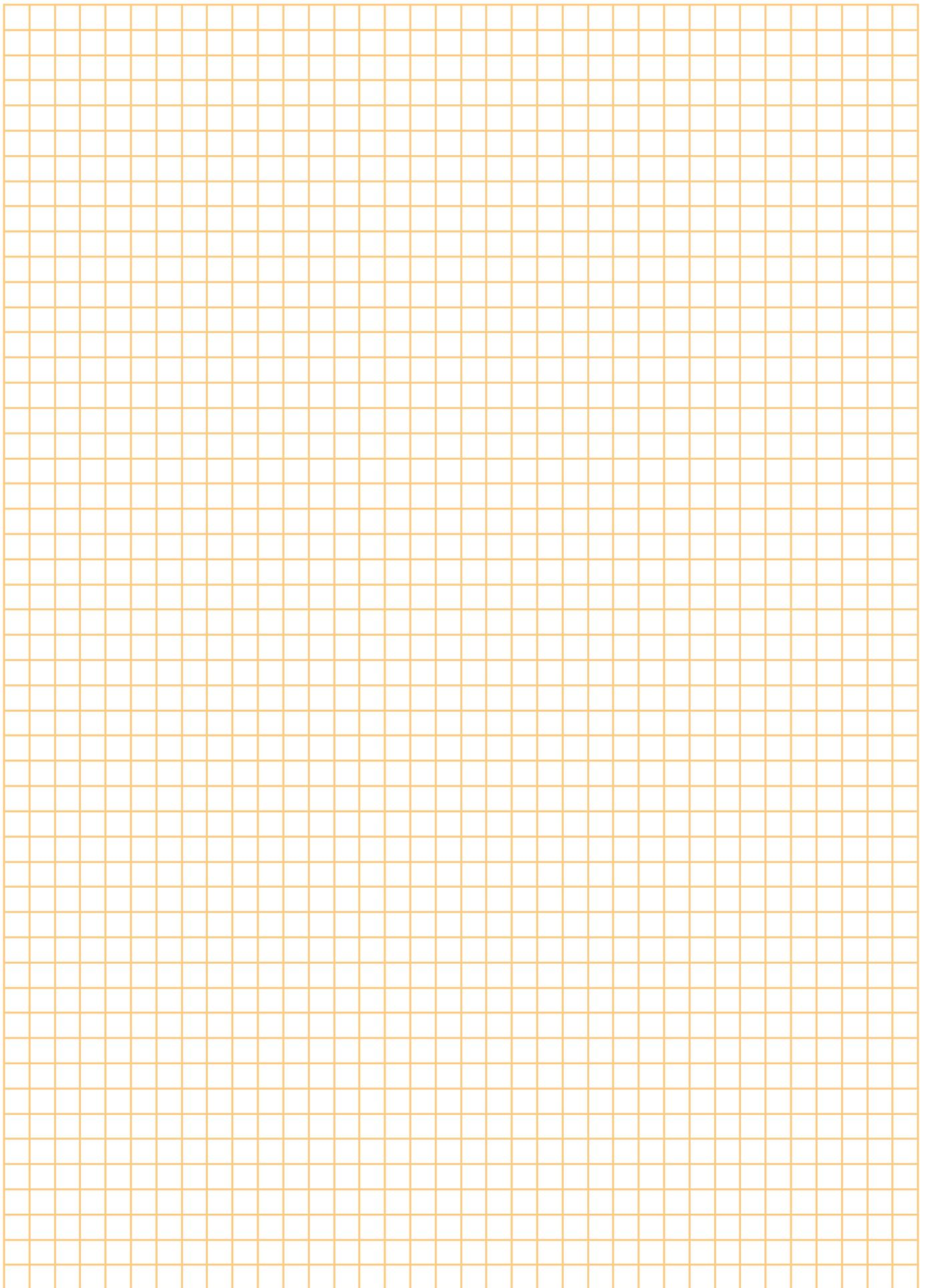

Type 2 Modular Single and Multi-pole SPD up to 50kA per pole



Classification UL 1449 3rd ed.:

Location of use:

Protection modes:

Protective elements:

Surge discharge ratings:

Housing:

Complies with:

Type 2

Sub-distribution boards

L - G (PE), L - N, N - G (PE) or L - L

MOV and GDT

I_{max} up to 50kA

Modular design

UL 1449 3rd Ed.

The new SAFETEC series of SPDs :

- **Are highly reliable - controlled disconnection, arc-quenching**
- **Are safer - controlled behaviour even when surge ratings are exceeded**
- **Have longer life - protection against ageing**
- **Have up to 20 years warranty**

SAFETEC C(R) UL Series:

SAFETEC C(R) UL

SAFETEC C(R) (2+0) UL

SAFETEC C(R) (3+0) UL

SAFETEC C(R) (4+0) UL

The modular SAFETEC C(R) series is suitable for all type of connections.

Patented TC* technology prevents catastrophic failures in case of TOV (temporary overvoltages).

All in one technology is a protection from overvoltages surges and transients. It has been developed to protect against partial direct and indirect lightning discharges and are intended to provide protection in zones O_B - 2 per IEC 62305.

*TC - Thermal control function





SAFETEC C(R) UL



- Classification UL 1449 3rd Ed.: Type 2
- Location of use: Sub-distribution boards
- Protection modes: L - G (PE), L - N, N - G (PE) or L - L
- Protective element: MOV and GDT
- Surge discharge rating: I_{max} up to 50kA
- Safety: TOV withstand for unlimited time
- Housing: Modular design
- Complies with: UL 1449 3rd Ed.



Technical data

Type		150	277	385	SAFETEC C(R)			750	880
					440	550			
Electrical characteristics									
Max. continuous operating voltage (AC)	MCOV	150V	300V	385V	440V	550V	750V	880V	
Nominal discharge current (8/20) per mode of protection	I_n	20kA	20kA	20kA	20kA	20kA	10kA	10kA	
Max. discharge current (8/20) per mode of protection	I_{max}	50kA	50kA	50kA	50kA	50kA	20kA	20kA	
Voltage protection rating per UL 1449 3rd ed.	VPR	1.2kV	1.6kV	1.8kV	2.0kV	2.5kV	2.5kV	3.0kV	
Short-circuit withstand rating	SCCR				200kA				
Follow current	I_{fi}				NO				
Response time	t_A				< 25ns				
Thermal protection					YES				
Mechanical characteristics									
Terminal screw torque					max. 3.0Nm				
Temperature range					- 40°C + 80°C				
Terminal cross section					35mm ² (solid) / 25mm ² (stranded)				
Mounting					35mm DIN rail, EN 60715				
Degree of protection					IP 20				
Housing material					thermoplastic; extinguishing degree UL 94 V-0				
Indication of disconnecter operation					red flag				
Remote contacts (RC)					YES				
Contact ratings					AC: 250V/0.5A; 125V/3A				
Terminal cross section					max. 1.5mm ²				
Remote terminal torque					0.25Nm				

Ordering information

MCOV	150	277	385	440	550	750	880
Ordering code SAFETEC C 50/xxx	516.058	516.060	516.062	516.064	516.066		
Ordering code SAFETEC CR 50/xxx (with remote contacts)	516.059	516.061	516.063	516.065	516.067		
Ordering code SAFETEC C 20/xxx						516.068	516.586
Ordering code SAFETEC CR 20/xxx (with remote contacts)						516.069	516.587
Ordering code Module SAFETEC C(R) 50/xxx	516.201	516.202	516.203	516.204	516.205		
Ordering code Module SAFETEC C(R) 20/xxx						516.206	516.585



SAFETEC C(R) UL Series



- Classification UL 1449 3rd Ed.: Type 2
- Location of use: Sub-distribution boards
- Protection modes: L - G (PE), L - N, N - G (PE) or L - L
- Protective element: MOV and GDT
- Surge discharge rating: I_{max} up to 50kA
- Safety: TOV withstand for unlimited time
- Housing: Modular design
- Complies with: UL 1449 3rd Ed.



Technical data

Type		150	277	SAFETEC C(R) (2+0), (3+0), (4+0)				750	880
Electrical characteristics									
Max. continuous operating voltage (AC)	MCOV	150V	300V	385V	440V	550V	750V	880V	
Nominal discharge current (8/20) per mode of protection	I_n	20kA	20kA	20kA	20kA	20kA	10kA	10kA	
Max. discharge current (8/20) per mode of protection	I_{max}	50kA	50kA	50kA	50kA	50kA	20kA	20kA	
Voltage protection rating per UL 1449 3rd ed.	VPR	1.2kV	1.6kV	1.8kV	2.0kV	2.5kV	2.5kV	3.0kV	
Short-circuit withstand rating	SCCR	200kA							
Follow current	I_{fi}	NO							
Response time	t_A	< 25ns							
Thermal protection		YES							
Mechanical characteristics									
Terminal screw torque		max. 3.0Nm							
Temperature range		- 40°C + 80°C							
Terminal cross section		35mm ² (solid) / 25mm ² (stranded)							
Mounting		35mm DIN rail, EN 60715							
Degree of protection		IP 20							
Housing material		thermoplastic; extinguishing degree UL 94 V-0							
Indication of disconnecter operation		red flag							
Remote contacts (RC)		YES							
Contact ratings		AC: 250V/0.5A; 125V/3A							
Terminal cross section		max. 1.5mm ²							
Remote terminal torque		0.25Nm							

Ordering information

MCOV	150	277	385	440	550	750	880
Ordering code SAFETEC C 100/xxx (2+0)	516.070	516.072	516.074	516.076	/		
Ordering code SAFETEC CR 100/xxx (2+0) (with remote contacts)	516.071	516.073	516.075	516.077	/		
Ordering code SAFETEC C 40/xxx (2+0)						516.080	516.588
Ordering code SAFETEC CR 40/xxx (2+0) (with remote contacts)						516.081	516.589
Ordering code SAFETEC C 150/xxx (3+0)	516.082	516.084	516.086	516.088	516.090		
Ordering code SAFETEC CR 150/xxx (3+0) (with remote contacts)	516.083	516.085	516.087	516.089	516.130		
Ordering code SAFETEC C 60/xxx (3+0)						516.091	516.590
Ordering code SAFETEC CR 60/xxx (3+0) (with remote contacts)						516.092	516.591
Ordering code SAFETEC C 200/xxx (4+0)	516.093	516.095	516.097	516.099	/		
Ordering code SAFETEC CR 200/xxx (4+0) (with remote contacts)	516.094	516.096	516.098	516.100	/		
Ordering code SAFETEC C 80/xxx (4+0)						516.103	516.592
Ordering code SAFETEC CR 80/xxx (4+0) (with remote contacts)						516.104	516.593
Ordering code Module SAFETEC C(R) 50/xxx	516.201	516.202	516.203	516.204	516.205		
Ordering code Module SAFETEC C(R) 20/xxx						516.206	516.585



APPROVED

FILE
E 335214

Dimensions, Internal configuration, Weight and Packaging

SAFETEC C(R) UL

Dimensions

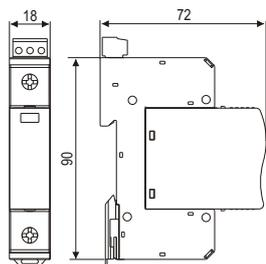

Internal configuration

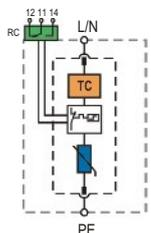

SAFETEC C 50/xxx	150	277	385	440	550
Dimensions DIN 43880	1TE				
Weight per unit	140g	140g	145g	150g	153g
SAFETEC CR 50/xxx	150	277	385	440	550
Weight per unit	148g	148g	153g	158g	161g
SAFETEC C 20/xxx	750 880				
Weight per unit	156g 156g				
SAFETEC CR 20/xxx	750 880				
Weight per unit	164g 164g				
Packaging dimensions (single unit)	108 x 74 x 24mm				
Min. packaging quantity	12 pcs.				

SAFETEC C(R) (2+0) UL

Dimensions

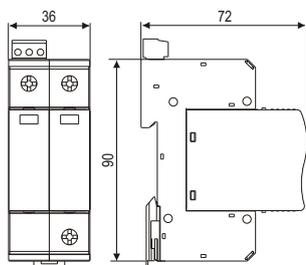

Internal configuration

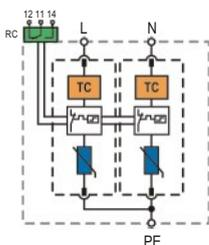

SAFETEC C 100/xxx (2+0)	150	277	385	440	
Dimensions DIN 43880	2TE				
Weight per unit	280g	281g	290g	299g	
SAFETEC CR 100/xxx (2+0)	150	277	385	440	
Weight per unit	288g	289g	298g	307g	
SAFETEC CR 40/xxx (2+0)	750 880				
Weight per unit	312g 312g				
SAFETEC CR 40/xxx (2+0)	750 880				
Weight per unit	320g 320g				
Packaging dimensions (single unit)	109 x 76.5 x 41.5mm				
Min. packaging quantity	7 pcs.				

SAFETEC C(R) (3+0) UL

Dimensions

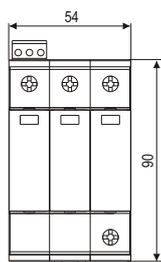

Internal configuration

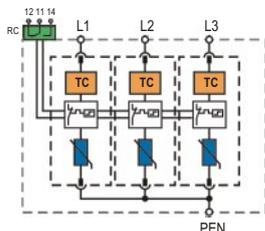

SAFETEC C 150/xxx (3+0)	150	277	385	440	550
Dimensions DIN 43880	3TE				
Weight per unit	420g	422g	435g	450g	459g
SAFETEC CR 150/xxx (3+0)	150	277	385	440	550
Weight per unit	428g	430g	443g	458g	467g
SAFETEC C 60/xxx (3+0)	750 880				
Weight per unit	468g 468g				
SAFETEC CR 60/xxx (3+0)	750 880				
Weight per unit	476g 476g				
Packaging dimensions (single unit)	109 x 76.5 x 60mm				
Min. packaging quantity	5 pcs.				



APPROVED

FILE
E 335214

Dimensions, Internal configuration, Weight and Packaging

SAFETEC C(R) (4+0) UL

Dimensions

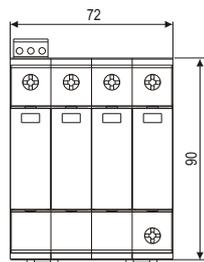

Internal configuration

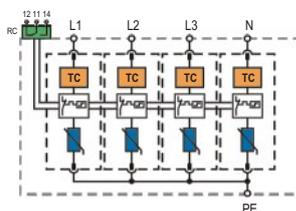

SAFETEC C 200/xxx (4+0)	150	277	385	440
Dimensions DIN 43880	4TE			
Weight per unit	560g	562g	580g	598g
SAFETEC CR 200/xxx (4+0)	150	277	385	440
Weight per unit	568g	570g	588g	606g
SAFETEC CR 80/xxx (4+0)				750 880
Weight per unit				624g 624g
SAFETEC CR 80/xxx (4+0)				750 880
Weight per unit				632g 632g
Packaging dimensions (single unit)	109 x 76.5 x 78mm			
Min. packaging quantity	3 pcs.			

Module SAFETEC C(R) UL

Dimensions

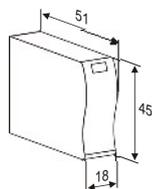

Internal configuration

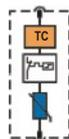

Module SAFETEC C(R) 50/xxx	150	277	385	440	550
Weight per unit	62g	66g	72g	74g	76g
Module SAFETEC C(R) 20/xxx					750 880
Weight per unit					78g 78g
Packaging dimensions	219 x 62 x 47mm				
Min. packaging quantity	12 pcs.				



SAFETEC C(R) UL Series

Network connections

- TN-S Network (Single-phase);
- Single-phase

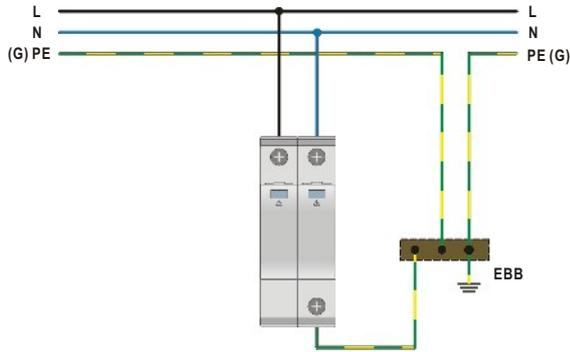

- TN-C Network (3-phase),
- Split phase System,
- 3-phase WYE without neutral,
- Delta Ungrounded

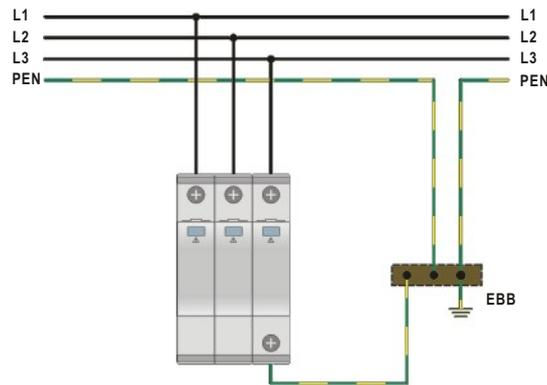

- TN-S Network (3-phase),
- 3-phase WYE with neutral,
- Delta Grounded Corner

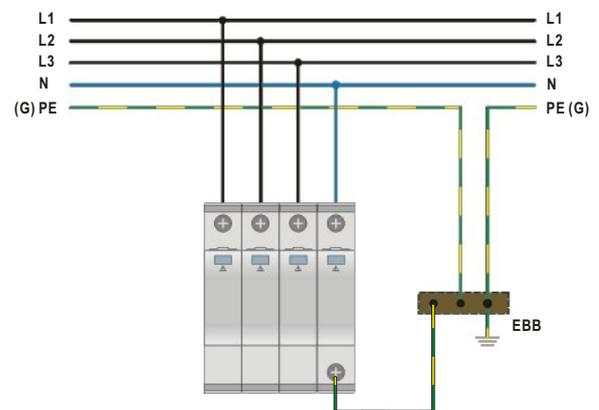

Class II Modular Single and Multi-pole SPD 40kA per pole



Category IEC / EN / VDE:

Location of use:

Protection modes:

Protective elements:

Surge discharge ratings:

Internal protection and safety:

Complies with:

Class II / Type 2 / C

Sub-distribution boards

L/N-PE, L-PEN, L-N, N-PE

MOV and GDT

I_{max} = 40kA

Separate thermal disconnecter for each MOV

IEC/EN 61643-11

PROTEC C(R) Series:

PROTEC C(R) 40/xxx

PROTUBE C 40

PROTEC C(R) 80/xxx (2+0)

PROTEC C(R) 120/xxx (3+0)

PROTEC C(R) 160/xxx (4+0)

PROTEC C(R) 80/xxx (1+1)

PROTEC C(R) 160/xxx (3+1)

The PROTEC C(R) series of overvoltage surge protective devices has been developed to protect low-voltage consumer installation against surges and effects of indirect lightning discharges and induced voltages. They are to be installed within lightning protection zones 0_B - 2 as per IEC 62305.

PROTEC C(R) series consists of a high performance varistor with thermal disconnection mechanism. The plug-in module / base facilitates replacement of a failed module *in situ* without the need to remove system wiring.

PROTUBE C is a modular, single pole housing design and consists of a high energy encapsulated gas discharge tube. It is utilized for galvanic separation between the N and PE conductors in a 1+1 or 3+1 power distribution networks.

PROTEC C(R) series complies with the IEC/EN 61643-11 standards and is applicable to the following network systems: TN-S, TN-C, IT and TT.



PROTEC C(R)



- **Category IEC / EN / VDE:** Class II / Type 2 / C
- **Location of use:** Sub-distribution boards
- **Network systems:** TN-S, TN-C, IT, TT
- **Protection modes:** L/N - PE, L- PEN
- **Protective element:** MOV
- **Surge discharge rating:** $I_{max} = 40kA$
- **MOV max. withstand capability 1 x 8/20:** 60kA
- **Housing:** Modular design
- **Complies with:** IEC/EN 61643-11



Technical data

Type		75	150	PROTEC C(R) 40/xxx			440
				275	320	385	
Electrical characteristics							
Max. continuous operating voltage (AC/DC)	U_c	75/100V	150/200V	275/350V	320/420V	385/500V	440/580V
Nominal discharge current (8/20)	I_n	20kA					
Max. discharge current (8/20)	I_{max}	40kA					
Protection level	U_p	< 0.6kV	< 0.9kV	< 1.5kV	< 1.5kV	< 1.9kV	< 2.2kV
Residual voltage at 5kA (8/20)	U_{res}	< 0.4kV	< 0.6kV	< 1.1kV	< 1.1kV	< 1.4kV	< 1.6kV
Follow current	I_{fi}	NO					
Response time	t_A	< 25ns					
Thermal protection		YES					
Back-up fuse (if mains > 125A)		125A gL					
Short-circuit withstand current	I_{SCCR}	25kA/50Hz					
Mechanical characteristics							
Terminal screw torque		max. 3.0Nm					
Temperature range		- 40°C + 80°C					
Terminal cross section		35mm ² (solid) / 25mm ² (stranded)					
Mounting		35mm DIN rail, EN 60715					
Degree of protection		IP 20					
Housing material		Thermoplastic; extinguishing degree UL 94 V-0					
Indication of disconnecter operation		red flag					
Remote contacts (RC)		YES					
Contact ratings		AC: 250V/0.5A; 125V/3A					
Terminal cross section		max. 1.5mm ²					
Remote terminal torque		0.25Nm					

Ordering information

U_c	75	150	275	320	385	440
Ordering code PROTEC C 40/xxx	50.0001	50.0003	50.0005	50.0007	50.0171	50.0009
Ordering code PROTEC CR 40/xxx (with remote contacts)	50.0011	50.0013	50.0015	50.0017	50.0175	50.0019
Ordering code Module PROTEC C(R) 40/xxx	50.0216	50.0217	50.0219	50.0220	50.0221	50.0222

PROTUBE C 40



- Category IEC / EN / VDE: Class II / Type 2 / C
- Location of use: Sub-distribution boards
- Network system: TT
- Protection modes: N - PE
- Protective element: GDT
- Surge discharge rating: $I_{max} = 40kA$
- MOV max. withstand capability 1 x 8/20: 60kA
- Housing: Modular design
- Complies with: IEC/EN 61643-11



Technical data

Type		PROTUBE C 40/255	
Electrical characteristics			
Max. continuous operating voltage (AC)	U_C		255V
Nominal discharge current (8/20)	I_n		20kA
Max. discharge current (8/20)	I_{max}		40kA
Protection level	U_p		< 1.5kV
Follow current	I_{fi}		100A _{RMS}
Response time	t_A		100ns
Mechanical characteristics			
Terminal screw torque			max. 3.0Nm
Temperature range			- 40°C + 80°C
Terminal cross section			35mm ² (solid) / 25mm ² (stranded)
Mounting			35mm DIN rail, EN 60715
Degree of protection			IP 20
Housing material			Thermoplastic; extinguishing degree UL 94 V-0

Ordering information

I_{max}	40
Ordering code PROTUBE C 40/255	50.3005
Ordering code Module PROTUBE C 40/255	50.0234

Dimensions, Internal configuration, Weight and Packaging

PROTEC C(R) 40/xxx

Dimensions

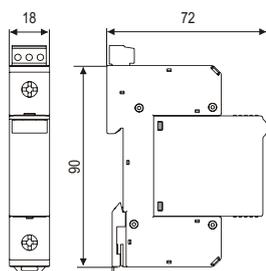

Internal configuration

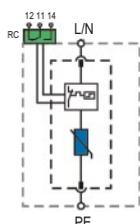

PROTEC C 40/xxx	75	150	275	320	385	440
Dimensions DIN 43880	1TE					
Weight per unit	112g	122g	128g	128g	129g	130g
PROTEC CR 40/xxx	75	150	275	320	385	440
Dimensions DIN 43880	1TE					
Weight per unit	117g	127g	133g	133g	134g	135g
Packaging dimensions (single unit)	108 x 74 x 24mm					
Min. packaging quantity	12 pcs.					

Module PROTEC C(R) 40/xxx

Dimensions

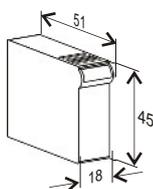

Internal configuration

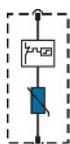

Module PROTEC C(R) 40/xxx	75	150	275	320	385	440
Weight per unit	44g	48g	52g	56g	58g	60g
Packaging dimensions	219 x 62 x 47mm					
Min. packaging quantity	12 pcs.					

PROTUBE C 40/255

Dimensions

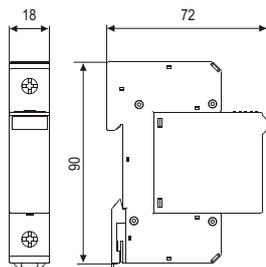

Internal configuration

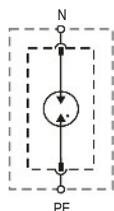

PROTUBE C 40/255	255
Dimensions DIN 43880	1TE
Weight per unit	118g
Packaging dimensions (single unit)	108 x 74 x 24mm
Min. packaging quantity	12 pcs.

Module PROTUBE C 40/255

Dimensions

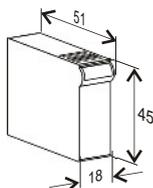

Internal configuration



Module PROTUBE C 40/255	255
Weight per unit	36g
Packaging dimensions	219 x 62 x 47mm
Min. packaging quantity	12 pcs.

PROTEC C(R) Series



- Category IEC / EN / VDE: Class II / Type 2 / C
- Location of use: Sub-distribution boards
- Network systems: TN-S, TN-C, IT
- Protection modes: L/N - PE, L- PEN
- Protective element: MOV
- Surge discharge rating: $I_{max} = 40kA$
- MOV max. withstand capability 1 x 8/20: 60kA per pole
- Housing: Modular design
- Complies with: IEC/EN 61643-11



Technical data

Type		150	275	320	385	440
		PROTEC C(R) yyy/xxx (2+0), (3+0), (4+0)				
Electrical characteristics						
Max. continuous operating voltage (AC/DC)	U_c	150/200V	275/350V	320/420V	385/500V	440/580V
Nominal discharge current (8/20)	I_n	20kA per pole				
Max. discharge current (8/20)	I_{max}	40kA per pole				
Protection level	U_p	< 0.9kV	< 1.5kV	< 1.5kV	< 1.9kV	< 2.2kV
Residual voltage at 5kA (8/20)	U_{res}	< 0.6kV	< 1.1kV	< 1.1kV	< 1.4kV	< 1.6kV
Follow current	I_{fi}	NO				
Response time	t_A	< 25ns				
Thermal protection		YES				
Back-up fuse (if mains > 125A)		125A gL				
Short-circuit withstand current	I_{SCCR}	25kA/50Hz				
Mechanical characteristics						
Terminal screw torque		max. 3.0Nm				
Temperature range		- 40°C + 80°C				
Terminal cross section		35mm ² (solid) / 25mm ² (stranded)				
Mounting		35mm DIN rail, EN 60715				
Degree of protection		IP 20				
Housing material		Thermoplastic; extinguishing degree UL 94 V-0				
Indication of disconnector operation		red flag				
Remote contacts (RC)		YES				
Contact ratings		AC: 250V/0.5A; 125V/3A				
Terminal cross section		max. 1.5mm ²				
Remote terminal torque		0.25Nm				

Ordering information

U_c	150	275	320	385	440
Ordering code PROTEC C 80/xxx (2+0)	50.0073	50.0075	50.0077	50.0179	50.0079
Ordering code PROTEC CR 80/xxx (2+0) (with remote contacts)	50.0081	50.0083	50.0085	50.0183	50.0087
Ordering code PROTEC C 120/xxx (3+0)	50.0105	50.0107	50.0109	50.0195	50.0111
Ordering code PROTEC CR 120/xxx (3+0) (with remote contacts)	50.0113	50.0115	50.0117	50.0199	50.0119
Ordering code PROTEC C 160/xxx (4+0)	50.0121	50.0123	50.0125	50.0203	50.0127
Ordering code PROTEC CR 160/xxx (4+0) (with remote contacts)	50.0129	50.0131	50.0133	50.0207	50.0135
Ordering code Module PROTEC C(R) 40/xxx	50.0217	50.0219	50.0220	50.0221	50.0222

Dimensions, Internal configuration, Weight and Packaging

PROTEC C(R) 80/xxx (2+0)

Dimensions

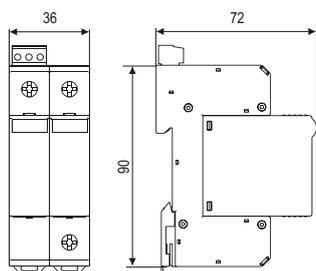

Internal configuration

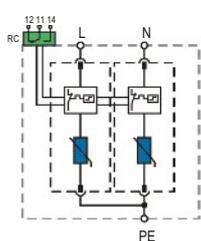

PROTEC C 80/xxx (2+0)	150	275	320	385	440
Dimensions DIN 43880	2TE				
Weight per unit	234g	244g	244g	245g	247g
PROTEC CR 80/xxx (2+0)	150	275	320	385	440
Dimensions DIN 43880	2TE				
Weight per unit	239g	249g	249g	250g	252g
Packaging dimensions (single unit)	109 x 76,5 x 41,5mm				
Min. packaging quantity	7 pcs.				

PROTEC C(R) 120/xxx (3+0)

Dimensions

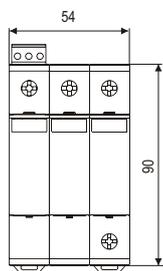

Internal configuration

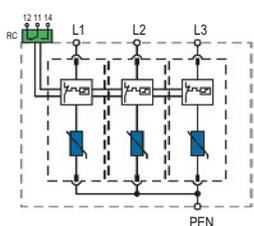

PROTEC C 120/xxx (3+0)	150	275	320	385	440
Dimensions DIN 43880	3TE				
Weight per unit	330g	352g	352g	354g	356g
PROTEC CR 120/xxx (3+0)	150	275	320	385	440
Dimensions DIN 43880	3TE				
Weight per unit	335g	357g	357g	359g	361g
Packaging dimensions (single unit)	109 x 76,5 x 60mm				
Min. packaging quantity	5 pcs.				

PROTEC C(R) 160/xxx (4+0)

Dimensions

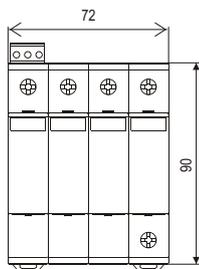

Internal configuration

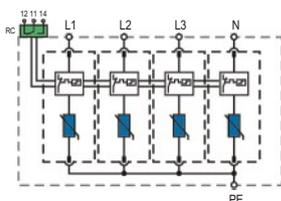

PROTEC C 160/xxx (4+0)	150	275	320	385	440
Dimensions DIN 43880	4TE				
Weight per unit	432g	456g	456g	460g	466g
PROTEC CR 160/xxx (4+0)	150	275	320	385	440
Dimensions DIN 43880	4TE				
Weight per unit	437g	461g	461g	465g	471g
Packaging dimensions (single unit)	109 x 76,5 x 78mm				
Min. packaging quantity	3 pcs.				

Module PROTEC C(R) 40/xxx

Dimensions

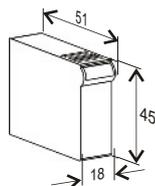

Internal configuration

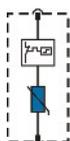

Module PROTEC C(R) 40/xxx	75	150	275	320	385	440
Weight per unit	44g	48g	52g	56g	58g	60g
Packaging dimensions	219 x 62 x 47mm					
Min. packaging quantity	12 pcs.					

PROTEC C(R) Series



- Category IEC / EN / VDE: Class II / Type 2 / C
- Location of use: Sub-distribution boards
- Network system: TT, TN-S
- Protection modes: L-N, N-PE
- Protective element: MOV and GDT
- Surge discharge rating: $I_{max} = 40kA$
- MOV max. withstand capability 1 x 8/20: 60kA per pole
- Housing: Modular design
- Complies with: IEC/EN 61643-11



Technical data

Type		150	275	320	385	440
Electrical characteristics						
Max. continuous operating voltage (AC/DC)	U_c (L-N)	150/200V	275/350V	320/420V	385/500V	440/580V
	U_c (N-PE)			255V		
Nominal discharge current (8/20)	I_n (L-N/N-PE)			20kA/20kA		
Max. discharge current (8/20)	I_{max} (L-N/N-PE)			40kA/40kA		
Protection level	U_p (L-N)	< 0.9kV	< 1.5kV	< 1.5kV	< 1.9kV	< 2.2kV
	U_p (N-PE)			< 1.5kV		
Residual voltage at 5kA (8/20)	U_{res} (L-N)	< 0.6kV	< 1.1kV	< 1.1kV	< 1.4kV	< 1.6kV
Follow current	I_{fi} (N-PE)			100ARMS		
Response time	t_A (L-N/N-PE)			< 25ns/100ns		
Thermal protection				YES		
Back-up fuse (if mains > 125A)	(L-N)			125A gL		
Short-circuit withstand current	I_{SCCR} (L-N)			25kA/50Hz		
Mechanical characteristics						
Terminal screw torque				max. 3.0Nm		
Temperature range				- 40°C + 80°C		
Terminal cross section				35mm ² (solid) / 25mm ² (stranded)		
Mounting				35mm DIN rail, EN 60715		
Degree of protection				IP 20		
Housing material				Thermoplastic; extinguishing degree UL 94 V-0		
Indication of disconnector operation				red flag		
Remote contacts (RC)				YES		
Contact ratings				AC: 250V/0.5A; 125V/3A		
Terminal cross section				max. 1.5mm ²		
Remote terminal torque				0.25Nm		

Ordering information

U_c	150	275	320	385	440
Ordering code PROTEC C 80/xxx (1+1)	50.0089	50.0091	50.0093	50.0187	50.0095
Ordering code PROTEC CR 80/xxx (1+1) (with remote contacts)	50.0097	50.0099	50.0101	50.0191	50.0103
Ordering code PROTEC C 160/xxx (3+1)	50.0137	50.0139	50.0141	50.0211	50.0143
Ordering code PROTEC CR 160/xxx (3+1) (with remote contacts)	50.0145	50.0147	50.0149	50.0215	50.0151
Ordering code Module PROTEC C(R) 40/xxx	50.0217	50.0219	50.0220	50.0221	50.0222
Ordering code Module PROTUBE C 40/255			50.0234		

Dimensions, Connection diagrams, Weight and Packaging

PROTEC C(R) 80/xxx (1+1)

Dimensions

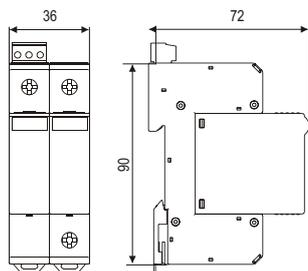

Internal configuration

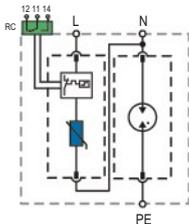

PROTEC C 80/xxx (1+1)	150	275	320	385	440
Dimensions DIN 43880	2TE				
Weight per unit	221g	225g	225g	226g	227g
PROTEC CR 80/xxx (1+1)	150	275	320	385	440
Dimensions DIN 43880	2TE				
Weight per unit	226g	230g	230g	231g	232g
Packaging dimensions (single unit)	109 x 76,5 x 41,5mm				
Min. packaging quantity	7 pcs.				

PROTEC C(R) 160/xxx (3+1)

Dimensions

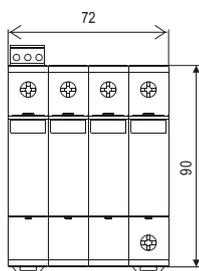

Internal configuration

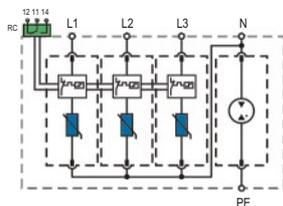

PROTEC C 160/xxx (3+1)	150	275	320	385	440
Dimensions DIN 43880	4TE				
Weight per unit	423g	441g	441g	445g	447g
PROTEC CR 160/xxx (3+1)	150	275	320	385	440
Dimensions DIN 43880	4TE				
Weight per unit	428g	446g	446g	450g	452g
Packaging dimensions (single unit)	109 x 76,5 x 78mm				
Min. packaging quantity	3 pcs.				

Module PROTEC C(R) 40/xxx

Dimensions

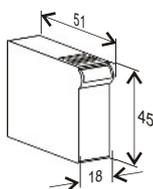

Internal configuration

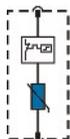

Module PROTEC C(R) 40/xxx	75	150	275	320	385	440
Weight per unit	44g	48g	52g	56g	58g	60g
Packaging dimensions	219 x 62 x 47mm					
Min. packaging quantity	12 pcs.					

Module PROTUBE C 40/255

Dimensions

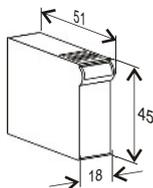

Internal configuration



Module PROTUBE C 40/255	255
Weight per unit	36g
Packaging dimensions	219 x 62 x 47mm
Min. packaging quantity	12 pcs.

PROTEC C(R) Series

Network connections

TN-S Network (Single-phase)

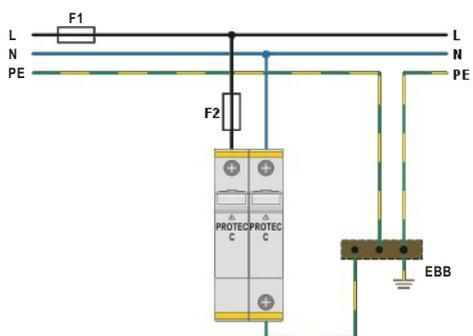

TT Network (Single-phase)

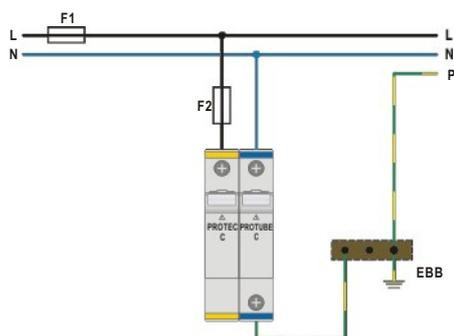

TN-C Network (Three-phase)

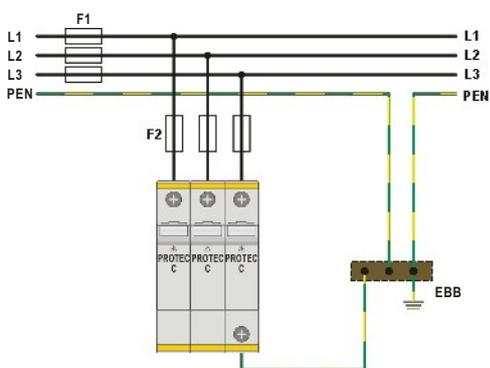

TN-S Network (Three-phase)

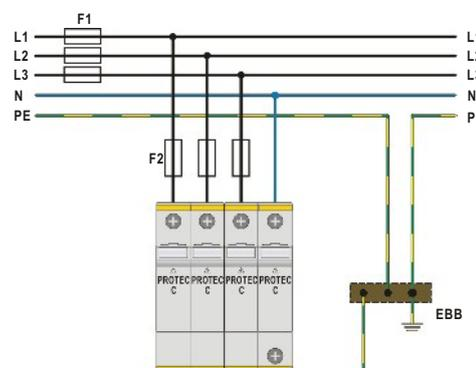

IT Network (Three-phase)

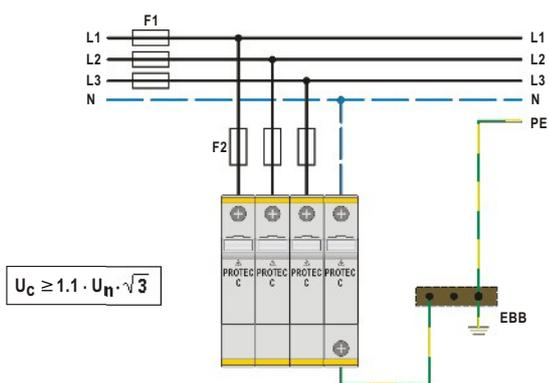

TT Network (Three-phase)

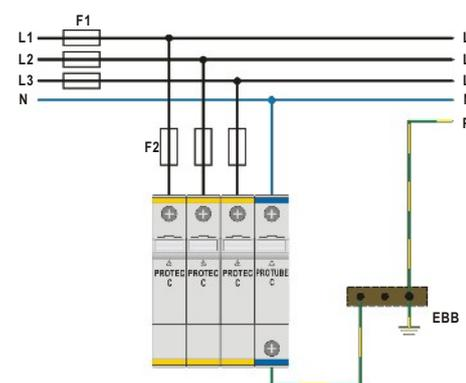

Back-up fuse

- $F1 > 125 A gL$ → $F2 = 125 A gL$
- $F1 \leq 125 A gL$ → $F2$

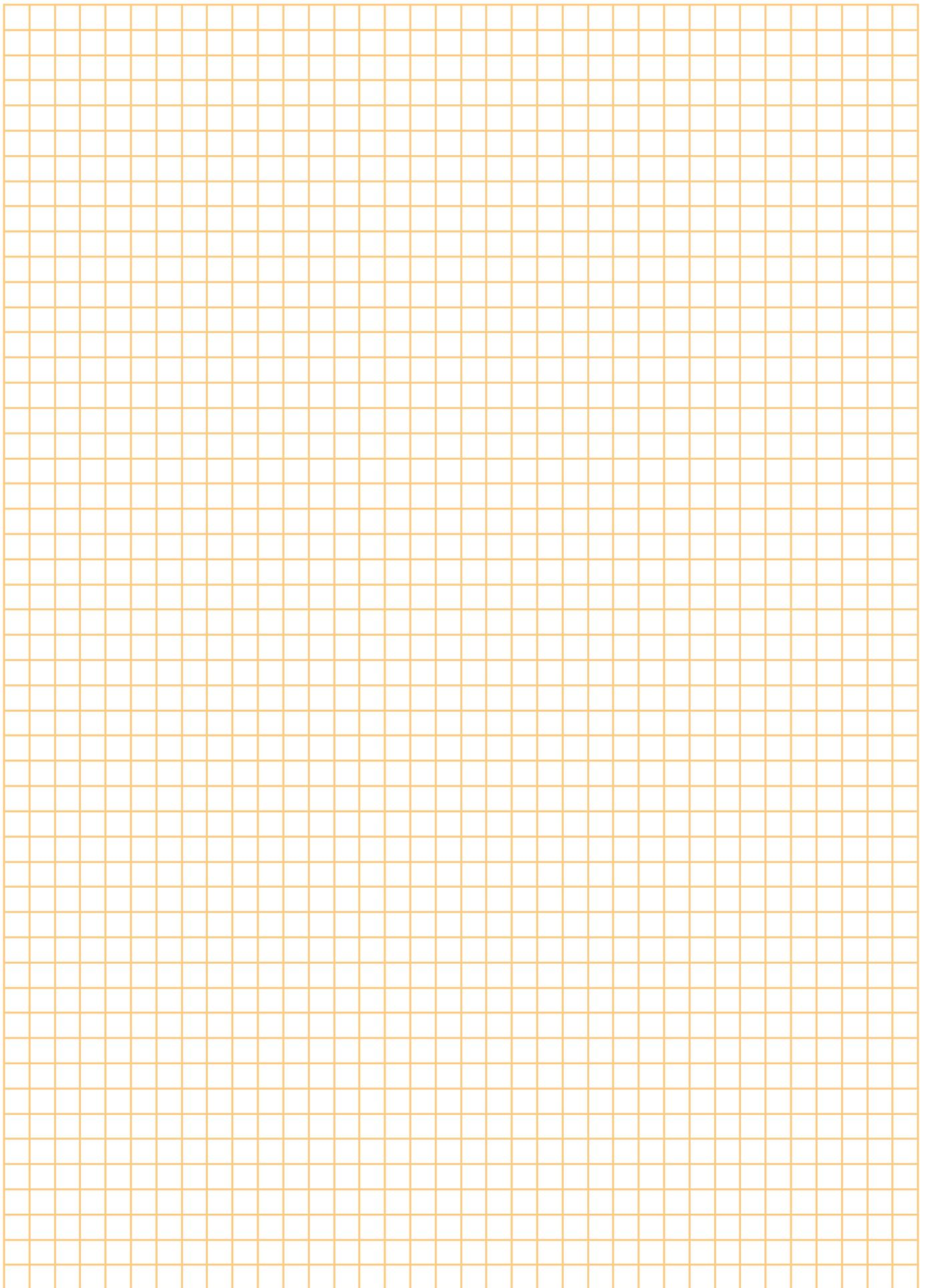

Class II Modular and Compact Single-pole SPD up to 40kA



Category IEC / EN / VDE:	Class II / Type 2 / C
Location of use:	Sub-distribution boards
Protection modes:	L/N-PE, L-PEN, N-PE
Protective elements:	MOV and GDT
Surge discharge ratings:	I_{max} up to 40kA
Internal protection and safety:	Separate thermal disconnecter for each MOV
Complies with:	IEC/EN 61643-11

PROTEC C(R) Series - variations:

PROTEC C(R) 20/xxx
PROTEC CN(R) 20/xxx
PROTEC CN(R) 40/xxx
PROTUBE CN 40
PROTEC CG(R) 20/xxx
PROTEC CG(R) 40/xxx

The PROTEC C(R) 20, PROTEC CN(R) and PROTEC CG(R) series of overvoltage surge protective devices have been developed to protect low-voltage consumer installation against surges and effects of indirect lightning discharges and induced voltages. They are installed within lightning protection zones 0_B - 2 as per IEC 62305.

PROTEC C(R) consists of a high performance varistor with thermal disconnection mechanism. Plug-in module / base facilitates replacement of a failed module *in situ* without the need to remove system wiring.

PROTUBE CN is a compact, single pole housing design and consists of a high energy encapsulated gas discharge tube. It is utilized for galvanic separation between the N and PE conductors in a 1+1 or 3+1 power distribution networks.

PROTEC CN(R) is a compact, single pole housing design and consists of a high performance varistor with thermal disconnection mechanism.

PROTEC CG(R) consists of a high performance varistor with thermal disconnection mechanism in series with an encapsulated gas discharge tube to limit leakage current. The plug-in module / base design facilitates replacement of a failed module *in situ* without the need to remove system wiring.

PROTEC C(R) 20, PROTEC CN(R) and PROTEC CG(R) series comply with the IEC/EN 61643-11 standards and are applicable to the following network systems: TN-S, TN-C, IT and TT.



PROTEC C(R) 20



- Category IEC / EN / VDE: Class II / Type 2 / C
- Location of use: Sub-distribution boards
- Network systems: TN-S, TN-C, IT
- Protection modes: L/N - PE, L- PEN
- Protective element: MOV
- Surge discharge rating: $I_{max} = 20kA$
- MOV max. withstand capability 1 x 8/20: 40kA
- Housing: Modular design
- Complies with: IEC/EN 61643-11



Technical data

Type		PROTEC C(R) 20/xxx				
		150	275	320	385	440
Electrical characteristics						
Max. continuous operating voltage (AC/DC)	U_c	150/200V	275/350V	320/420V	385/500V	440/580V
Nominal discharge current (8/20)	I_n	10kA				
Max. discharge current (8/20)	I_{max}	20kA				
Protection level	U_p	< 0.7kV	< 1.2kV	< 1.2kV	< 1.6kV	< 1.8kV
Residual voltage at 5kA (8/20)	U_{res}	< 0.6kV	< 1.1kV	< 1.1kV	< 1.4kV	< 1.6kV
Follow current	I_{fi}	NO				
Response time	t_A	< 25ns				
Thermal protection		YES				
Back-up fuse (if mains > 100A)		100A gL				
Short-circuit withstand current	I_{SCCR}	25kA/50Hz				
Mechanical characteristics						
Terminal screw torque		max. 3.0Nm				
Temperature range		- 40°C + 80°C				
Terminal cross section		35mm ² (solid) / 25mm ² (stranded)				
Mounting		35mm DIN rail, EN 60715				
Degree of protection		IP 20				
Housing material		Thermoplastic; extinguishing degree UL 94 V-0				
Indication of disconnector operation		red flag				
Remote contacts (RC)		YES				
Contact ratings		AC: 250V/0.5A; 125V/3A				
Terminal cross section		max. 1.5mm ²				
Remote terminal torque		0.25Nm				

Ordering information

U_c	150	275	320	385	440
Ordering code PROTEC C 20/xxx	50.0037	50.0039	50.0041	50.0315	50.0043
Ordering code PROTEC CR 20/xxx (with remote contacts)	50.0045	50.0047	50.0049	50.0317	50.0051
Ordering code Module PROTEC C(R) 20/xxx	50.0479	50.0480	50.0481	50.0482	50.0483

PROTEC CN(R) 20



- **Category IEC / EN / VDE:** Class II / Type 2 / C
- **Location of use:** Sub-distribution boards
- **Network systems:** TN-S, TN-C, IT
- **Protection modes:** L/N - PE, L- PEN
- **Protective element:** MOV
- **Surge discharge rating:** $I_{max} = 20kA$
- **MOV max. withstand capability 1 x 8/20:** 35kA
- **Housing:** Compact design
- **Complies with:** IEC/EN 61643-11



Technical data

Type	PROTEC CN(R) 20/xxx					
	150	275	320	385	440	
Electrical characteristics						
Max. continuous operating voltage (AC/DC)	U_c	150/200V	275/350V	320/420V	385/500V	440/580V
Nominal discharge current (8/20)	I_n	10kA				
Max. discharge current (8/20)	I_{max}	20kA				
Protection level	U_p	< 0.7kV	< 1.2kV	< 1.2kV	< 1.6kV	< 1.8kV
Residual voltage at 5kA (8/20)	U_{res}	< 0.6kV	< 1.1kV	< 1.1kV	< 1.4kV	< 1.6kV
Follow current	I_{fi}	NO				
Response time	t_A	< 25ns				
Thermal protection		YES				
Back-up fuse (if mains > 100A)		100A gL				
Short-circuit withstand current	I_{SCCR}	25kA/50Hz				
Mechanical characteristics						
Terminal screw torque		max. 3.0Nm				
Temperature range		- 40°C + 80°C				
Terminal cross section		35mm ² (solid) / 25mm ² (stranded)				
Mounting		35mm DIN rail, EN 60715				
Degree of protection		IP 20				
Housing material		Thermoplastic; extinguishing degree UL 94 V-0				
Indication of disconnector operation		red flag				
Remote contacts (RC)		YES				
Contact ratings		AC: 250V/0.5A; 125V/3A				
Terminal cross section		max. 1.5mm ²				
Remote terminal torque		0.25Nm				

Ordering information

U_c	150	275	320	385	440
Ordering code PROTEC CN 20/xxx	507.253	507.254	507.255	507.256	507.257
Ordering code PROTEC CN(R) 20/xxx (with remote contacts)	507.258	507.259	507.260	507.261	507.262

PROTEC CN(R) 40



- Category IEC / EN / VDE: Class II / Type 2 / C
- Location of use: Sub-distribution boards
- Network systems: TN-S, TN-C, IT
- Protection modes: L/N - PE, L- PEN
- Protective element: MOV
- Surge discharge rating: $I_{max} = 40kA$
- MOV max. withstand capability 1 x 8/20: 50kA
- Housing: Compact design
- Complies with: IEC/EN 61643-11



Technical data

Type		75	150	PROTEC CN(R) 40/xxx			440
				275	320	385	
Electrical characteristics							
Max. continuous operating voltage (AC/DC)	U_c	75/100V	150/200V	275/350V	320/420V	385/500V	440/580V
Nominal discharge current (8/20)	I_n	20kA					
Max. discharge current (8/20)	I_{max}	40kA					
Protection level	U_p	< 0.6kV	< 0.9kV	< 1.5kV	< 1.5kV	< 1.9kV	< 2.2kV
Residual voltage at 5kA (8/20)	U_{res}	< 0.4kV	< 0.6kV	< 1.1kV	< 1.1kV	< 1.4kV	< 1.6kV
Follow current	I_{fi}	NO					
Response time	t_A	< 25ns					
Thermal protection		YES					
Back-up fuse (if mains > 125A)		125A gL					
Short-circuit withstand current	I_{SCCR}	25kA/50Hz					
Mechanical characteristics							
Terminal screw torque		max. 3.0Nm					
Temperature range		- 40°C + 80°C					
Terminal cross section		35mm ² (solid) / 25mm ² (stranded)					
Mounting		35mm DIN rail, EN 60715					
Degree of protection		IP 20					
Housing material		Thermoplastic; extinguishing degree UL 94 V-0					
Indication of disconnector operation		red flag					
Remote contacts (RC)		YES					
Contact ratings		AC: 250V/0.5A; 125V/3A					
Terminal cross section		max. 1.5mm ²					
Remote terminal torque		0.25Nm					

Ordering information

U_c	75	150	275	320	385	440
Ordering code PROTEC CN 40/xxx	507.001	507.003	507.005	507.007	507.021	507.009
Ordering code PROTEC CNR 40/xxx (with remote contacts)	507.011	507.013	507.015	507.017	507.023	507.019

PROTUBE CN 40



- Category IEC / EN / VDE: Class II / Type 2 / C
- Location of use: Sub-distribution boards
- Network system: TT
- Protection modes: N - PE
- Protective element: GDT
- Surge discharge rating: $I_{max} = 40kA$
- MOV max. withstand capability 1 x 8/20: 60kA
- Housing: Compact design
- Complies with: IEC/EN 61643-11



Technical data

Type		PROTUBE CN 40/255	
Electrical characteristics			
Max. continuous operating voltage (AC)	U_c		255V
Nominal discharge current (8/20)	I_n		20kA
Max. discharge current (8/20)	I_{max}		40kA
Protection level	U_p		< 1.2kV
Follow current	I_{fi}		100A _{RMS}
Response time	t_A		100ns
Mechanical characteristics			
Terminal screw torque			max. 3.0Nm
Temperature range			- 40°C + 80°C
Terminal cross section			35mm ² (solid) / 25mm ² (stranded)
Mounting			35mm DIN rail, EN 60715
Degree of protection			IP 20
Housing material			Thermoplastic; extinguishing degree UL 94 V-0

Ordering information

I_{max}	40
Ordering code PROTUBE CN 40/255	507.574

Dimensions, Internal configurations, Weight and Packaging

PROTEC C(R) 20/xxx

Dimensions

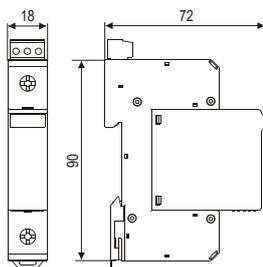

Internal configuration

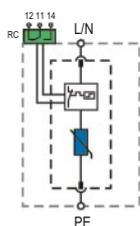

PROTEC C 20/xxx	150	275	320	385	440
Dimensions DIN 43880	1TE				
Weight per unit	119g	125g	125g	126g	127g
PROTEC CR 20/xxx	150	275	320	385	440
Dimensions DIN 43880	1TE				
Weight per unit	124g	130g	130g	131g	132g
Packaging dimensions (single unit)	108 x 74 x 24mm				
Min. packaging quantity	12 pcs.				

Module PROTEC C(R) 20/xxx

Dimensions

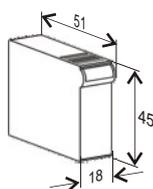

Internal configuration

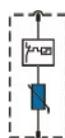

Module PROTEC C(R) 40/xxx	150	275	320	385	440
Weight per unit	48g	56g	56g	60g	58g
Packaging dimensions	219 x 62 x 47mm				
Min. packaging quantity	12 pcs.				

PROTEC CN(R) xx/xxx

Dimensions

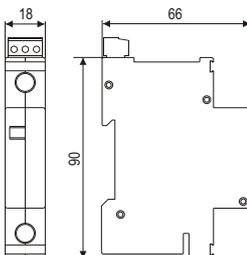

Internal configuration

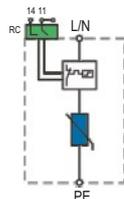

PROTEC CN 20/xxx	150	275	320	385	440
Dimensions DIN 43880	1TE				
Weight per unit	131g	109g	109g	136g	137g
PROTEC CNR 20/xxx	150	275	320	385	440
Dimensions DIN 43880	1TE				
Weight per unit	136g	114g	114g	141g	142g
Packaging dimensions (single unit)	108 x 74 x 24mm				
Min. packaging quantity	12 pcs.				

PROTEC CN 40/xxx	75	150	275	320	385	440
Dimensions DIN 43880	1TE					
Weight per unit	127g	134g	112g	112g	139g	140g
PROTEC CN(R) 40/xxx	75	150	275	320	385	440
Dimensions DIN 43880	1TE					
Weight per unit	132g	139g	117g	117g	144g	145g
Packaging dimensions (single unit)	108 x 74 x 24mm					
Min. packaging quantity	12 pcs.					

PROTUBE CN 40/255

Dimensions

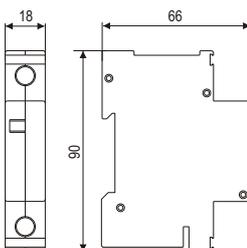

Internal configuration

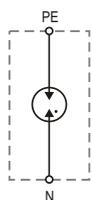

PROTUBE CN 40/255	255
Dimensions DIN 43880	1TE
Weight per unit	122g
Packaging dimensions (single unit)	108 x 74 x 24mm
Min. packaging quantity	12 pcs.

PROTEC CG(R) 20



- **Category IEC / EN / VDE:** Class II / Type 2 / C
- **Location of use:** Sub-distribution boards
- **Network systems:** TN-S, TN-C, TT, IT
- **Protection modes:** L/N - PE, L- PEN
- **Protective element:** MOV and GDT
- **Surge discharge rating:** $I_{max} = 20kA$
- **MOV max. withstand capability 1 x 8/20:** 40kA
- **Housing:** Modular design
- **Complies with:** IEC/EN 61643-11



Technical data

Type	PROTEC CG(R) 20/xxx			
	150	275	385	
Electrical characteristics				
Max. continuous operating voltage (AC/DC)	U_c	150/200V	275/350V	385/500V
Nominal discharge current (8/20)	I_n		10kA	
Max. discharge current (8/20)	I_{max}		20kA	
Protection level	U_p	< 0.8kV	< 1.5kV	< 1.8kV
Residual voltage at 5kA (8/20)	U_{res}	< 0.6kV	< 1.2kV	< 1.5kV
Follow current	I_{fi}		NO	
Response time	t_A		< 25ns	
Thermal protection			YES	
Back-up fuse (if mains > 100A)			100A gL	
Short-circuit withstand current	I_{SCCR}		25kA/50Hz	
Mechanical characteristics				
Terminal screw torque			max. 3.0Nm	
Temperature range			- 40°C + 80°C	
Terminal cross section			35mm ² (solid) / 25mm ² (stranded)	
Mounting			35mm DIN rail, EN 60715	
Degree of protection			IP 20	
Housing material			Thermoplastic; extinguishing degree UL 94 V-0	
Indication of disconnecter operation			red flag	
Remote contacts (RC)			YES	
Contact ratings			AC: 250V/0.5A; 125V/3A	
Terminal cross section			max. 1.5mm ²	
Remote terminal torque			0.25Nm	

Ordering information

U_c	150	275	385
Ordering code PROTEC CG 20/xxx	50.0239	50.0241	50.0243
Ordering code PROTEC CGR 20/xxx (with remote contacts)	50.0245	50.0247	50.0249
Ordering code Module PROTEC CG(R) 20/xxx	50.0235	50.0236	50.0237

PROTEC CG(R) 40



- Category IEC / EN / VDE: Class II / Type 2 / C
- Location of use: Sub-distribution boards
- Network systems: TN-S, TN-C, TT, IT
- Protection modes: L/N - PE, L- PEN
- Protective element: MOV and GDT
- Surge discharge rating: $I_{max} = 40kA$
- MOV max. withstand capability 1 x 8/20: 60kA
- Housing: Modular design
- Complies with: IEC/EN 61643-11



Technical data

Type	PROTEC CG(R) 40/xxx			
	150	275	385	
Electrical characteristics				
Max. continuous operating voltage (AC/DC)	U_c	150/200V	275/350V	385/500V
Nominal discharge current (8/20)	I_n		20kA	
Max. discharge current (8/20)	I_{max}		40kA	
Protection level	U_p	< 0.9kV	< 1.5kV	< 1.9kV
Residual voltage at 5kA (8/20)	U_{res}	< 0.6kV	< 1.2kV	< 1.5kV
Follow current	I_{fi}		NO	
Response time	t_A		< 25ns	
Thermal protection			YES	
Back-up fuse (if mains > 125A)			125A gL	
Short-circuit withstand current	I_{SCCR}		25kA/50Hz	
Mechanical characteristics				
Terminal screw torque			max. 3.0Nm	
Temperature range			- 40°C + 80°C	
Terminal cross section			35mm ² (solid) / 25mm ² (stranded)	
Mounting			35mm DIN rail, EN 60715	
Degree of protection			IP 20	
Housing material			Thermoplastic; extinguishing degree UL 94 V-0	
Indication of disconnecter operation			red flag	
Remote contacts (RC)			YES	
Contact ratings			AC: 250V/0.5A; 125V/3A	
Terminal cross section			max. 1.5mm ²	
Remote terminal torque			0.25Nm	

Ordering information

U_c	150	275	385
Ordering code PROTEC CG 40/xxx	50.0323	50.0325	50.0327
Ordering code PROTEC CGR 40/xxx (with remote contacts)	50.0329	50.0331	50.0333
Ordering code Module PROTEC CG(R) 40/xxx	50.0502	50.0503	50.0504

Dimensions, Internal configuration, Weight and Packaging

PROTEC CG(R) 20/xxx

Dimensions

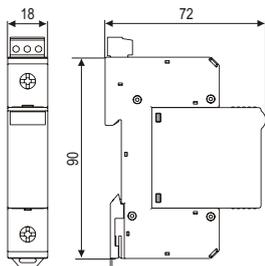

Internal configuration

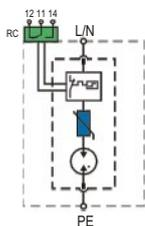

PROTEC CG 20/xxx	150	275	385
Dimensions DIN 43880	1TE		
Weight per unit	112g	128g	130g
PROTEC CGR 20/xxx	150	275	385
Dimensions DIN 43880	1TE		
Weight per unit	117g	133g	135g
Packaging dimensions (single unit)	108 x 74 x 24mm		
Min. packaging quantity	12 pcs.		

Module PROTEC CG(R) 20/xxx

Dimensions

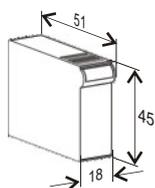

Internal configuration

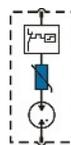

Module PROTEC CG(R) 20/xxx	150	275	385
Weight per unit	40g	56g	58g
Packaging dimensions	219 x 62 x 47mm		
Min. packaging quantity	12 pcs.		

PROTEC CG(R) 40/xxx

Dimensions

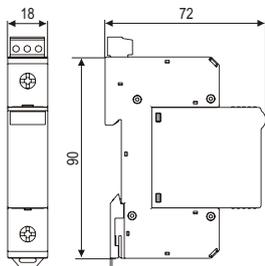

Internal configuration

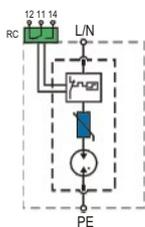

PROTEC CG 40/xxx	150	275	385
Dimensions DIN 43880	1TE		
Weight per unit	112g	130g	132g
PROTEC CGR 40/xxx	150	275	385
Dimensions DIN 43880	1TE		
Weight per unit	117g	135g	137g
Packaging dimensions (single unit)	108 x 74 x 24mm		
Min. packaging quantity	12 pcs.		

Module PROTEC CG(R) 40/xxx

Dimensions

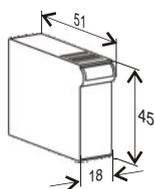

Internal configuration

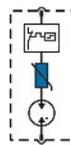

Module PROTEC CG(R) 40/xxx	150	275	385
Weight per unit	40g	56g	58g
Packaging dimensions	219 x 62 x 47mm		
Min. packaging quantity	12 pcs.		

PROTEC C(R) 20 Series

Network connections

TN-S Network (Single-phase)

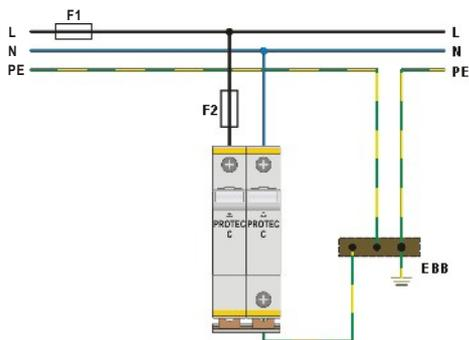

TT Network (Single-phase)

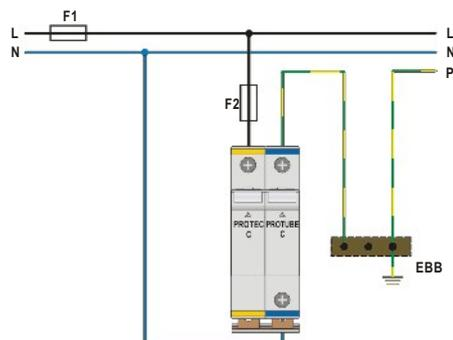

TN-C Network (Three-phase)

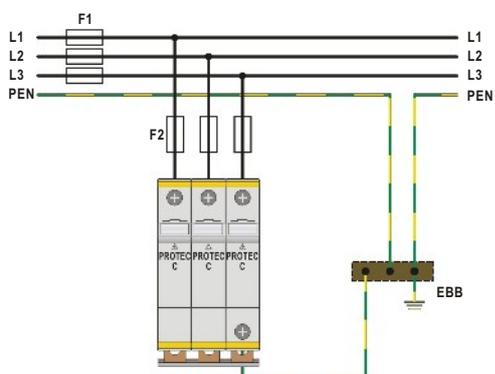

TN-S Network (Three-phase)

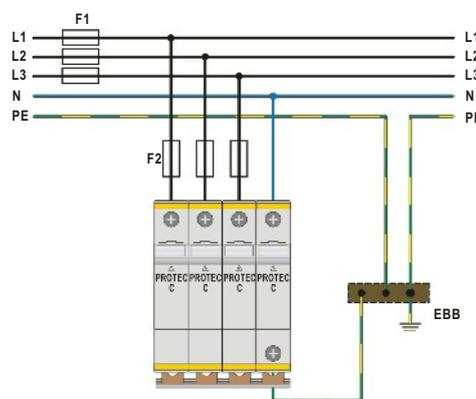

IT Network (Three-phase)

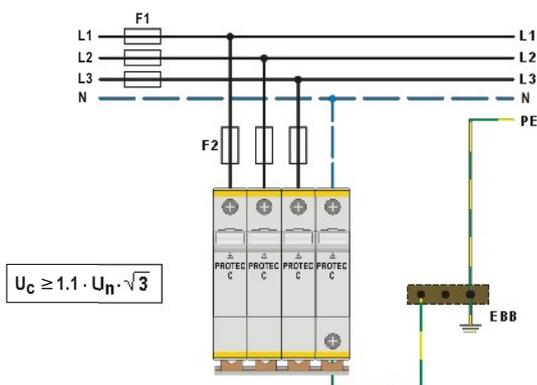

TT Network (Three-phase)

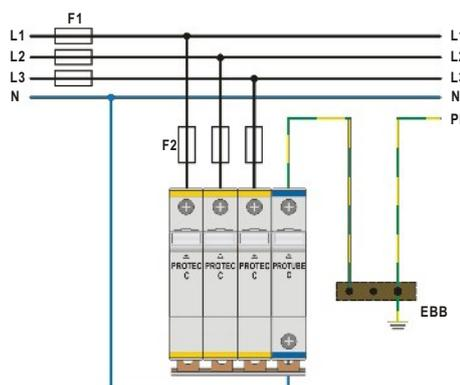

Back-up fuse

- F1 > 100 A gL → F2 = 100 A gL
- F1 ≤ 100 A gL → F2

PROTEC CN(R) Series

Network connections

TN-S Network (Single-phase)

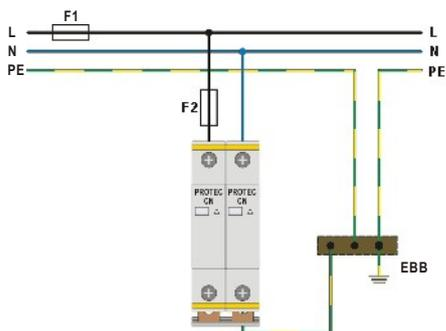

TT Network (Single-phase)

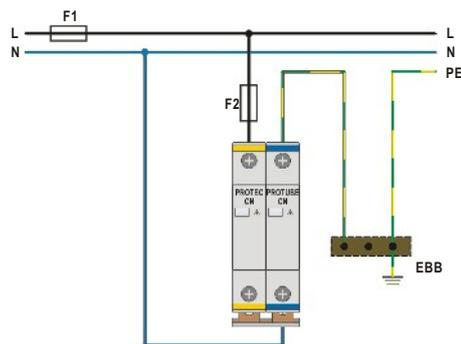

TN-C Network (Three-phase)

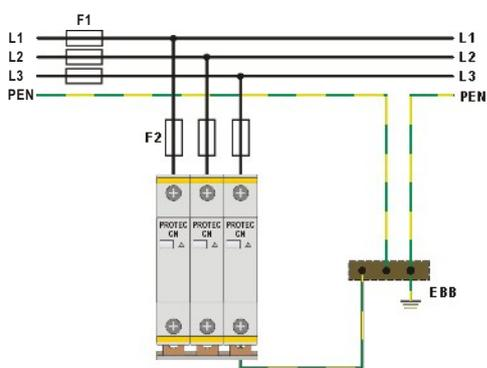

TN-S Network (Three-phase)

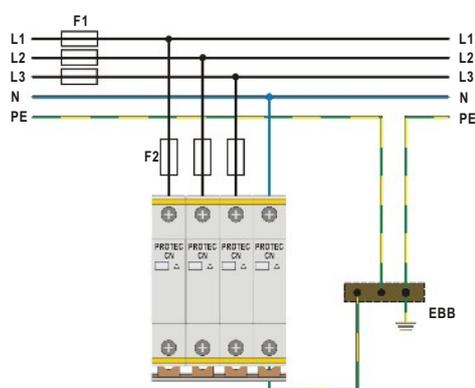

IT Network (Three-phase)

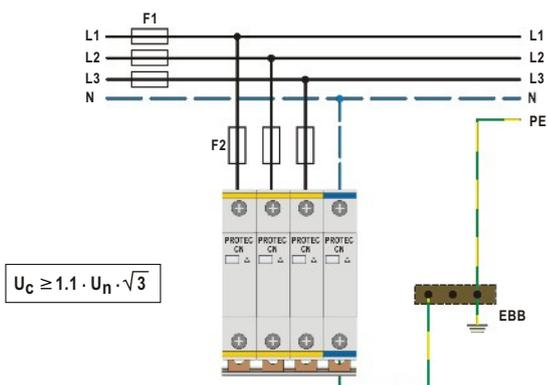

TT Network (Three-phase)

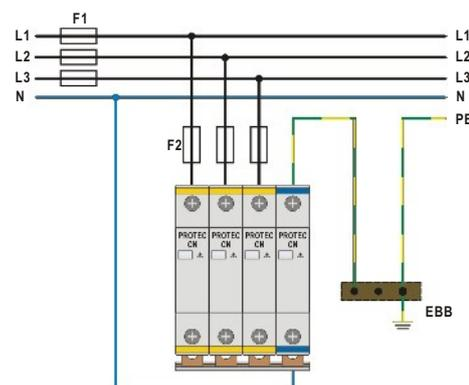

Back-up fuse
PROTEC CN(R) 20 Series

- F1 > 100 A gL → F2 = 100 A gL
- F1 ≤ 100 A gL → F2

PROTEC CN(R) 40 Series

- F1 > 125 A gL → F2 = 125 A gL
- F1 ≤ 125 A gL → F2

PROTEC CG(R) Series

Network connections

TN-S Network (Single-phase)

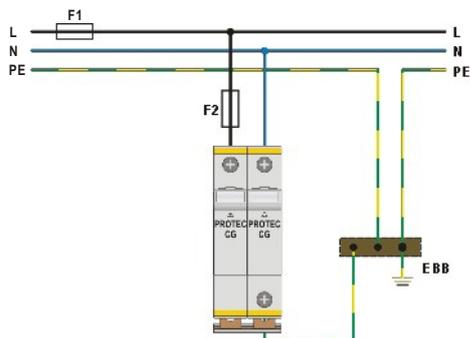

TT Network (Single-phase)

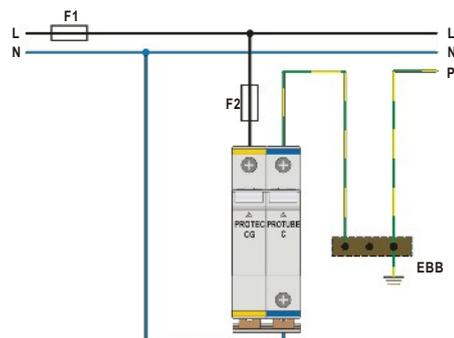

TN-C Network (Three-phase)

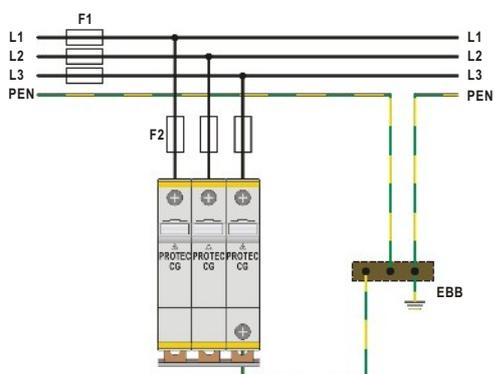

TN-S Network (Three-phase)

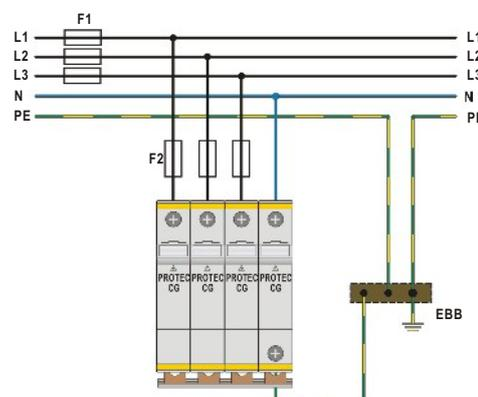

TT Network (Three-phase)

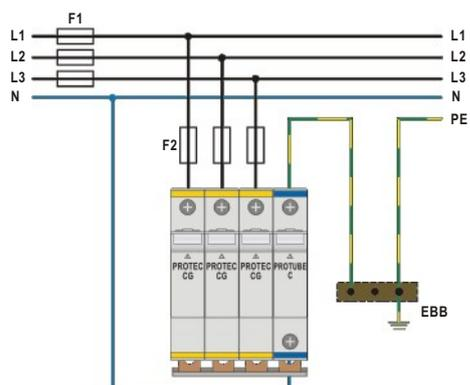

Back-up fuse
PROTEC CG(R) 20 Series

- $F1 > 100 \text{ A gL}$ → $F2 = 100 \text{ A gL}$
- $F1 \leq 100 \text{ A gL}$ → $F2$

PROTEC CG(R) 40 Series

- $F1 > 125 \text{ A gL}$ → $F2 = 125 \text{ A gL}$
- $F1 \leq 125 \text{ A gL}$ → $F2$

Class II Modular Multi-pole SPD up to 40kA per pole



Category IEC / EN / VDE:	Class II / Type 2 / C
Location of use:	Sub-distribution boards
Protection modes:	L/N-PE, L-PEN, L-N, N-PE
Protective elements:	MOV and GDT
Surge discharge ratings:	I_{max} up to 40kA
Internal protection and safety:	Separate thermal disconnecter for each MOV
Complies with:	IEC/EN 61643-11

PROTEC CMG(R) 40/xxx (2+0)

PROTEC CM(R) Series:

PROTEC CM(R) 80/xxx (2+0)

PROTEC CM(R) 80/xxx (1+1)

PROTEC CM(R) 80A/xxx (1+1)

The PROTEC CM(R) and PROTEC CMG(R) series of overvoltage surge protective devices have been developed to protect low-voltage consumer installation against surges and effects of indirect lightning discharges and induced voltages. They are to be installed within lightning protection zones 0_B - 2 as per IEC 62305.

PROTEC CM(R) is available in two configurations: 1+1 or 2+0. 1+1 version consists of high performance varistor with thermal disconnection mechanism and an encapsulated gas discharge tube. 2+0 version consists of two high performance varistors with thermal disconnection mechanism. Plug-in module / base facilitates replacement of a failed module *in situ* without the need to remove system wiring.

PROTEC CMG(R) consists of two high performance varistors with thermal disconnection mechanism in series with an encapsulated gas discharge tube to limit leakage current. Plug-in module / base facilitates replacement of a failed module *in situ* without the need to remove system wiring.

PROTEC CM(R) and PROTEC CMG(R) series comply with the IEC/EN 61643-11 standards and are applicable to the following network systems: TN-S, IT and TT.

PROTEC CMG(R) 40 (2+0)



- Category IEC / EN / VDE: Class II / Type 2 / C
- Location of use: Sub-distribution boards
- Network system: TN-S
- Protection modes: L/N - PE, L- N
- Protective element: MOV and GDT
- Surge discharge rating: $I_{max} = 20kA$
- Housing: Modular design
- Complies with: IEC/EN 61643-11



Technical data

Type	PROTEC CMG(R) 40/xxx (2+0)		
	150	275	
Electrical characteristics			
Max. continuous operating voltage (AC/DC)	U_c	150/200V	275/350V
Nominal discharge current (8/20)	I_n (L/N-PE, L-N)	10kA per pole	
Max. discharge current (8/20)	I_{max} (L/N-PE, L-N)	20kA per pole	
Protection level	U_p (L/N-PE)	< 0.7kV	< 1.1kV
	U_p (L-N)	< 1.2kV	< 1.9kV
Residual voltage at 3kA (8/20)	U_{res} (L/N-PE)	< 0.5kV	< 0.8kV
	U_{res} (L-N)	< 0.8kV	< 1.4kV
Follow current	I_{fi}	NO	
Response time	t_A (L/N-PE, L-N)	< 100ns/< 25ns	
Thermal protection		YES	
Back-up fuse (if mains > 100A)		100A gL	
Short-circuit withstand current	I_{scCR}	25kA/50Hz	
Mechanical characteristics			
Temperature range		- 40°C + 80°C	
Terminal screw torque	Upper terminals	max. 2.0Nm	
	Lower terminal	max. 3.0Nm	
Terminal cross section	Upper terminals	6mm ² (solid) / 4mm ² (stranded)	
	Lower terminal	35mm ² (solid) / 25mm ² (stranded)	
Mounting		35mm DIN rail, EN 60715	
Degree of protection		IP 20	
Housing material		Thermoplastic; extinguishing degree UL 94 V-0	
Indication of disconnecter operation		red flag	
Remote contacts (RC)		YES	
Contact ratings		AC: 250V/0.5A; 125V/3A	
Terminal cross section		max. 1.5mm ²	
Remote terminal torque		0.25Nm	

Ordering information

U_c	150	275
Ordering code PROTEC CMG 40/xxx (2+0)	508.197	508.198
Ordering code PROTEC CMGR 40/xxx (2+0) (with remote contacts)	508.199	508.200
Ordering code Module PROTEC CMG(R) 40/xxx	508.201	508.202

PROTEC CM(R) 80 (2+0)



- Category IEC / EN / VDE: Class II / Type 2 / C
- Location of use: Sub-distribution boards
- Network system: TN-S
- Protection modes: L/N - PE
- Protective element: MOV
- Surge discharge rating: $I_{max} = 40kA$
- Housing: Modular design
- Complies with: IEC/EN 61643-11



Technical data

Type	PROTEC CM(R) 80/xxx (2+0)					
	150	275	320	385	440	
Electrical characteristics						
Max. continuous operating voltage (AC/DC)	U_c	150/200V	275/350V	320/420V	385/500V	440/580V
Nominal discharge current (8/20)	I_n	15kA per pole				
Max. discharge current (8/20)	I_{max}	40kA per pole				
Protection level	U_p (L/N-PE)	< 0.8kV	< 1.4kV	< 1.4kV	< 1.8kV	< 2.0kV
Residual voltage at 5kA (8/20)	U_{res} (L/N-PE)	< 0.6kV	< 1.1kV	< 1.1kV	< 1.6kV	< 1.8kV
Follow current	I_{fi}	NO				
Response time	t_A	< 25ns				
Thermal protection		YES				
Back-up fuse (if mains > 100A)		100A gL				
Short-circuit withstand current	I_{SCCR}	25kA/50Hz				
Mechanical characteristics						
Temperature range		- 40°C + 80°C				
Terminal screw torque	Upper terminals	max. 2.0Nm				
	Lower terminal	max. 3.0Nm				
Terminal cross section	Upper terminals	6mm ² (solid) / 4mm ² (stranded)				
	Lower terminal	35mm ² (solid) / 25mm ² (stranded)				
Mounting		35mm DIN rail, EN 60715				
Degree of protection		IP 20				
Housing material		Thermoplastic; extinguishing degree UL 94 V-0				
Indication of disconnector operation		red flag				
Remote contacts (RC)		YES				
Contact ratings		AC: 250V/0.5A; 125V/3A				
Terminal cross section		max. 1.5mm ²				
Remote terminal torque		0.25Nm				

Ordering information

U_c	150	275	320	385	440
Ordering code PROTEC CM 80/xxx (2+0)	508.001	508.003	508.005	508.109	508.007
Ordering code PROTEC CMR 80/xxx (2+0) (with remote contacts)	508.009	508.011	508.013	508.111	508.015
Ordering code Module PROTEC CM(R) 80/xxx	508.174	508.164	508.175	508.146	508.147

PROTEC CM(R) 80(A) (1+1)



- Category IEC / EN / VDE: Class II / Type 2 / C
- Location of use: Sub-distribution boards
- Network system: TT, TN-S
- Protection modes: L-N, N-PE
- Protective element: MOV and GDT
- Surge discharge rating: $I_{max} = 40kA/40kA$ (MOV/GDT)
- Housing: Modular design
- Complies with: IEC/EN 61643-11



Technical data

Type		150	275	320	385	440
Electrical characteristics						
Max. continuous operating voltage (AC/DC)	U_c	150/200V	275/350V	320/420V	385/500V	440/580V
Nominal discharge current (8/20)	I_n (L-N/N-PE)	15kA/20kA				
Max. discharge current (8/20)	I_{max} (L-N/N-PE)	40kA/40kA				
Protection level	U_p (L-N)	< 0.8kV	< 1.4kV	< 1.4kV	< 1.8kV	< 2.0kV
	U_p (N-PE)	< 1.5kV				
Residual voltage at 5kA (8/20)	U_{res} (L-N)	< 0.6kV	< 1.1kV	< 1.1kV	< 1.6kV	< 1.8kV
Follow current	I_{fi} (N-PE)	100ARMS				
Response time	t_A (L-N/N-PE)	< 25ns/< 100ns				
Thermal protection		YES				
Back-up fuse (if mains > 100A)		100A gL				
Short-circuit withstand current	I_{SCCR}	25kA/50Hz				
Mechanical characteristics						
Temperature range		- 40°C + 80°C				
Terminal screw torque	Upper terminals	max. 2.0Nm				
	Lower terminal	max. 3.0Nm				
Terminal cross section	Upper terminals	6mm ² (solid) / 4mm ² (stranded)				
	Lower terminal	35mm ² (solid) / 25mm ² (stranded)				
Mounting		35mm DIN rail, EN 60715				
Degree of protection		IP 20				
Housing material		Thermoplastic; extinguishing degree UL 94 V-0				
Indication of disconnector operation		red flag				
Remote contacts (RC)		YES				
Contact ratings		AC: 250V/0.5A; 125V/3A				
Terminal cross section		max. 1.5mm ²				
Remote terminal torque		0.25Nm				

Ordering information

U_c	150	275	320	385	440
Ordering code PROTEC CM 80/xxx (1+1)	508.045	508.047	508.049	508.117	508.051
Ordering code PROTEC CMR 80/xxx (1+1) (with remote contacts)	508.053	508.055	508.057	508.119	508.059
Ordering code Module PROTEC CM(R) 80/xxx	508.186	508.187	508.188	508.189	508.190
U_c	150	275	320	385	440
Ordering code PROTEC CM 80A/xxx (1+1)	508.120	508.122	508.124	508.126	508.128
Ordering code PROTEC CMR 80A/xxx (1+1) (with remote contacts)	508.130	508.132	508.134	508.136	508.138
Ordering code Module PROTEC CM(R) 80A/xxx	508.176	508.143	508.177	508.144	508.145

Dimensions, Internal configuration, Weight and Packaging

PROTEC CMG(R) 40/xxx (2+0)

Dimensions

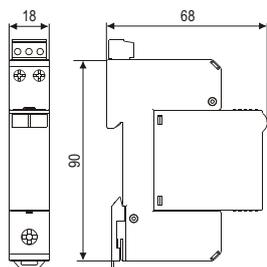

Internal configuration

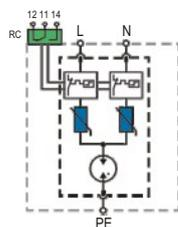

PROTEC CMG 40/xxx (2+0)	150	275
Dimensions DIN 43880	1TE	
Weight per unit	130g	146g
PROTEC CMGR 40/xxx (2+0)	150	275
Dimensions DIN 43880	1TE	
Weight per unit	135g	151g
Packaging dimensions (single unit)	108 x 74 x 24mm	
Min. packaging quantity	12 pcs.	

Module PROTEC CMG(R) 40/xxx (2+0)

Dimensions

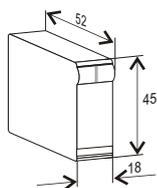

Internal configuration

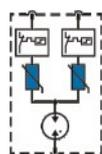

Module PROTEC CMG(R) 40/xxx (2+0)	150	275
Weight per unit	63g	79g
Packaging dimensions	219 x 62 x 47mm	
Min. packaging quantity	12 pcs.	

PROTEC CM(R) 80/xxx (2+0)

Dimensions

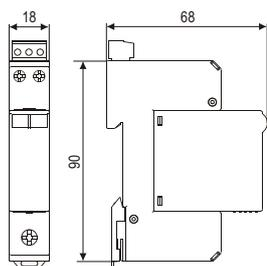

Internal configuration

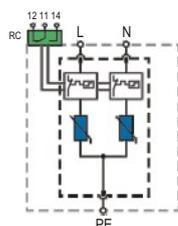

PROTEC CM 80/xxx (2+0)	150	275	320	385	440
Dimensions DIN 43880	1TE				
Weight per unit	134g	144g	144g	150g	152g
PROTEC CMR 80/xxx (2+0)	150	275	320	385	440
Dimensions DIN 43880	1TE				
Weight per unit	139g	149g	149g	155g	157g
Packaging dimensions (single unit)	108 x 74 x 24mm				
Min. packaging quantity	12 pcs.				

Module PROTEC CM(R) 80/xxx (2+0)

Dimensions

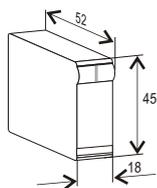

Internal configuration

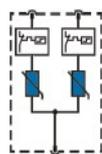

Module PROTEC CM(R) 80/xxx (2+0)	150	275	320	385	440
Weight per unit	67g	78g	78g	83g	85g
Packaging dimensions	219 x 62 x 47mm				
Min. packaging quantity	12 pcs.				

Dimensions, Internal configuration, Weight and Packaging

PROTEC CM(R) 80/xxx (1+1)

Dimensions

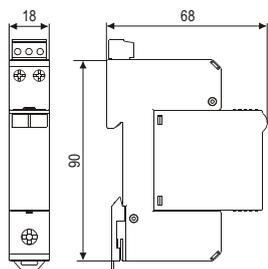

Internal configuration

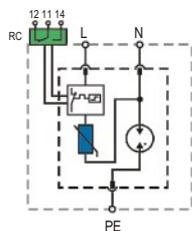

PROTEC CM 80/xxx (1+1)	150	275	320	385	440
Dimensions DIN 43880	1TE				
Weight per unit	124g	126g	126g	129g	130g
PROTEC CMR 80/xxx (1+1)	150	275	320	385	440
Dimensions DIN 43880	1TE				
Weight per unit	129g	131g	131g	134g	135g
Packaging dimensions (single unit)	108 x 74 x 24mm				
Min. packaging quantity	12 pcs.				

Module PROTEC CM(R) 80/xxx (1+1)

Dimensions

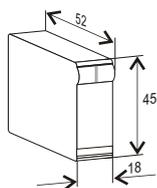

Internal configuration

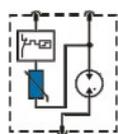

Module PROTEC CM(R) 80/xxx (1+1)	150	275	320	385	440
Weight per unit	57g	59g	59g	62g	63g
Packaging dimensions	219 x 62 x 47mm				
Min. packaging quantity	12 pcs.				

PROTEC CM(R) 80A/xxx (1+1)

Dimensions

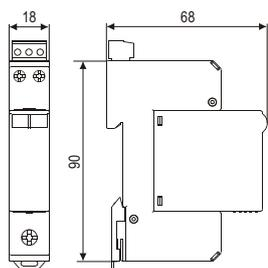

Internal configuration

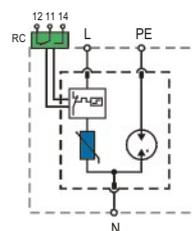

PROTEC CM 80A/xxx (1+1)	150	275	320	385	440
Dimensions DIN 43880	1TE				
Weight per unit	124g	126g	126g	129g	130g
PROTEC CMR 80A/xxx (1+1)	150	275	320	385	440
Dimensions DIN 43880	1TE				
Weight per unit	129g	131g	131g	134g	135g
Packaging dimensions (single unit)	108 x 74 x 24mm				
Min. packaging quantity	12 pcs.				

Module PROTEC CM(R) 80A/xxx (1+1)

Dimensions

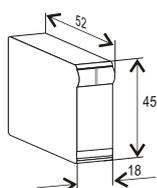

Internal configuration

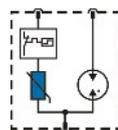

Module PROTEC CM(R) 80A/xxx (1+1)	150	275	320	385	440
Weight per unit	57g	59g	59g	62g	63g
Packaging dimensions	219 x 62 x 47mm				
Min. packaging quantity	12 pcs.				

**PROTEC CMG(R) Series
PROTEC CM(R) Series**

Network connections

TN-S Network (Single-phase)

PROTEC CMG(R) 40 (2+0)
PROTEC CM(R) 80 (2+0)

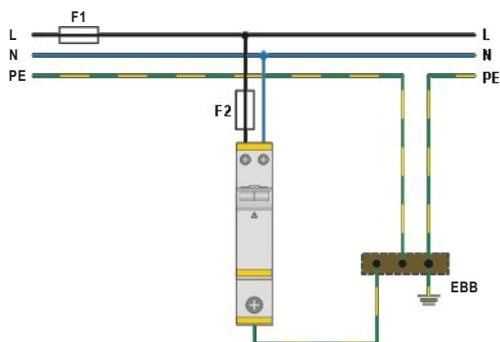

TN-S Network (Three-phase)

2x PROTEC CMG(R) 40 (2+0)
2x PROTEC CM(R) 80 (2+0)

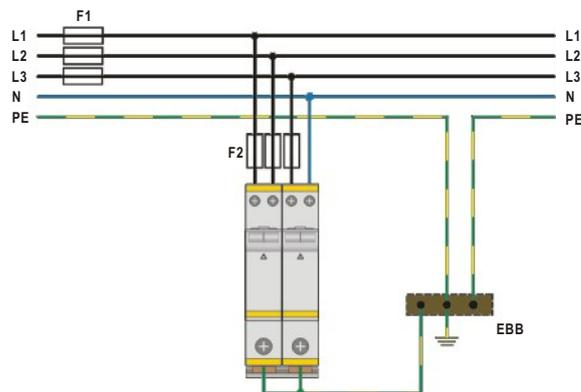

TT Network (Single-phase)

PROTEC CM(R) 80 (1+1)

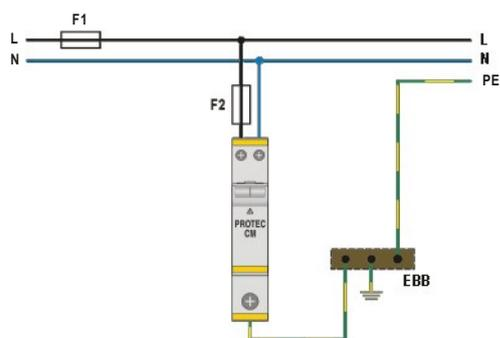

TT Network (Three-phase)

PROTEC CM(R) 80 (2+0) + PROTEC CM(R) 80A (1+1)

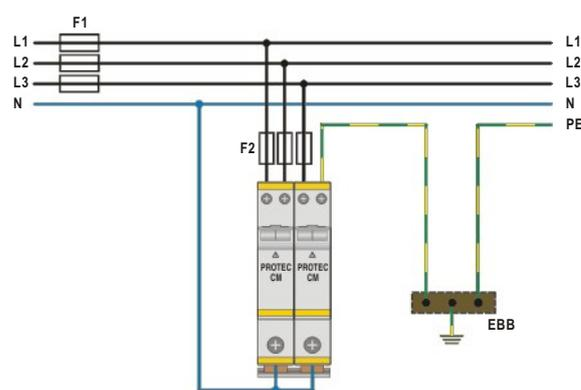

Back-up fuse



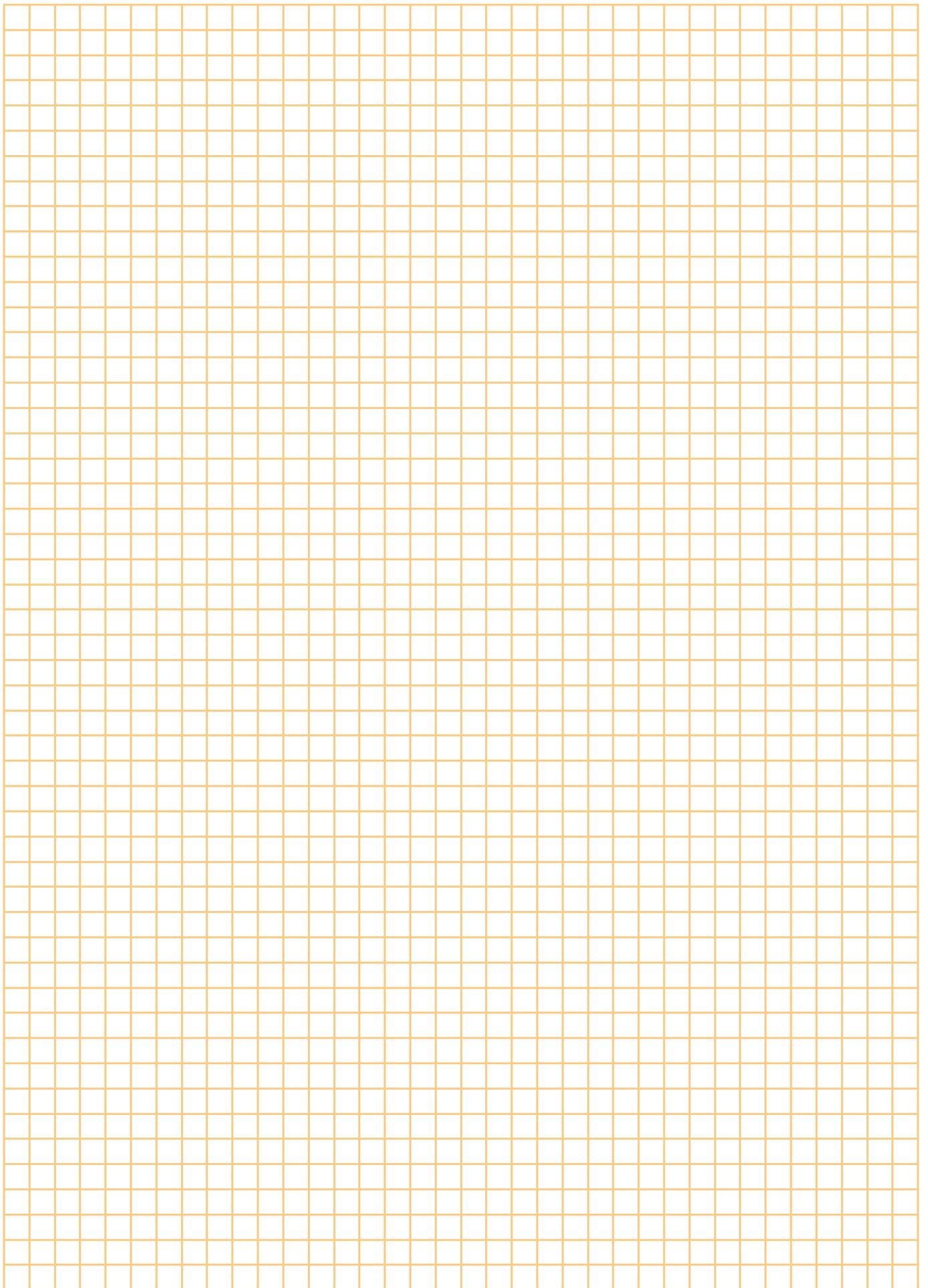

Class III Modular and Compact Single and Multi-pole SPD



Category IEC / EN / VDE:	Class III / Type 3 / D
Location of use:	Sub-distribution boards, power outlets and/or PCBs
Protection modes:	L/N-PE
Protective elements:	MOV, GDT or EMI filter
Surge discharge ratings:	U_{oc} up to 10kV
Internal protection and safety:	Separate thermal disconnector for each MOV
Complies with:	IEC/EN 61643-11

PROTEC D(R) 10/xxx
PROTEC DM(R) 20/xxx (2+0)
PROTEC DMG(R) 20/xxx (2+0)
PROLED 275 16A Series

MPE-MINI
MPE-MINI LED
ZE 200-PS
VTC 10/xxx
PROFILT D xxx

SPDs Class I and Class II are not enough to protect sensitive electronic elements. Overvoltage waves are slowly increasing and, at a greater distance, reoccurring and threatening devices. Incidence of low value surges, which are still too high for electronic elements, is still common in the object itself. They are caused by activation/switching of major appliances, inductive devices and motors, industrial systems operation. They intended to provide protection in zones 2 - 3 as per IEC 62305.

The PROTEC D series of overvoltage surge protective devices has been developed to protect against indirect lightning discharges and induced voltages. The plug-in module/base design facilitate replacement of a failed module without the need to remove system wiring etc.

PROLED series is designed for advanced 3-phase devices, equipment and systems up to 16A/230VAC per phase.

MPE series is designed for installation into electrical installation systems, cable ducts and wiring sockets.

ZE 200-PS is designed for plug in to the power outlet.

VTC series is designed for mounting on printed circuit boards (PCBs).

PROFILT D series contains surge arresters and filter, which are connected in serial.

PROTEC D(R) 10



- Category IEC / EN / VDE: Class III / Type 3 / D
- Location of use: Sub-distribution boards
- Network systems: TN-S, TN-C, TT
- Protection modes: L/N - PE
- Protective element: MOV
- Surge discharge rating: $U_{oc} = 10kV$
- Housing: Modular design
- Complies with: IEC/EN 61643-11



Technical data

Type	PROTEC D(R) 10/xxx				
	150	275	320	385	440
Electrical characteristics					
Max. continuous operating voltage (AC/DC) U_c	150/200V	275/350V	320/420V	385/500V	440/580V
Open circuit voltage of the combination wave generator U_{oc}	10kV				
Max. discharge current (8/20) I_{max}	10kA				
Protection level U_p	< 0.8kV	< 1.2kV	< 1.2kV	< 1.6kV	< 2.0kV
Follow current I_{fi}	NO				
Response time t_A	< 25ns				
Thermal protection	YES				
Back-up fuse (if mains > 63A)	63A gL				
Short-circuit withstand current I_{SCCR}	10kA/50Hz				
Mechanical characteristics					
Temperature range	- 40°C + 80°C				
Terminal screw torque	max. 3.0Nm				
Terminal cross section	35mm ² (solid) / 25mm ² (stranded)				
Mounting	35mm DIN rail, EN 60715				
Degree of protection	IP 20				
Housing material	Thermoplastic; extinguishing degree UL 94 V-0				
Indication of disconnector operation	red flag				
Remote contacts (RC)	YES				
Contact ratings	AC: 250V/0.5A; 125V/3A				
Terminal cross section	max. 1.5mm ²				
Remote terminal torque	0.25Nm				

Ordering information

U_c	150	275	320	385	440
Ordering code PROTEC D 10/xxx	50.8601	50.8603	50.8605	50.8617	50.8607
Ordering code PROTEC DR 10/xxx (with remote contacts)	50.8609	50.8611	50.8613	50.8619	50.8615
Ordering code Module PROTEC D(R) 40/xxx	50.8620	50.8621	50.8622	50.8623	50.8624

PROTEC DM(R) 20 (2+0)



- Category IEC / EN / VDE: Class III / Type 3 / D
- Location of use: Sub-distribution boards
- Network systems: TN-S, TT
- Protection modes: L/N - PE
- Protective element: MOV
- Surge discharge rating: $U_{oc} = 10kV$
- Housing: Modular design
- Complies with: IEC/EN 61643-11



Technical data

Type	PROTEC DM(R) 20/xxx (2+0)					
	150	275	320	385	440	
Electrical characteristics						
Max. continuous operating voltage (AC/DC)	U_c	150/200V	275/350V	320/420V	385/500V	440/580V
Open circuit voltage of the combination wave generator	U_{oc}	10kV				
Max. discharge current (8/20)	I_{max}	10kA per pole				
Protection level	U_p (L/N-PE)	< 0.8kV	< 1.2kV	< 1.2kV	< 1.6kV	< 2.0kV
Follow current	I_{fi}	NO				
Response time	t_A	< 25ns				
Thermal protection		YES				
Back-up fuse (if mains > 63A)		63A gL				
Short-circuit withstand current	I_{SCCR}	10kA/50Hz				
Mechanical characteristics						
Temperature range		- 40°C + 80°C				
Terminal screw torque	Upper terminals	max. 2.0Nm				
	Lower terminal	max. 3.0Nm				
Terminal cross section	Upper terminals	6mm ² (solid) / 4mm ² (stranded)				
	Lower terminal	35mm ² (solid) / 25mm ² (stranded)				
Mounting		35mm DIN rail, EN 60715				
Degree of protection		IP 20				
Housing material		Thermoplastic; extinguishing degree UL 94 V-0				
Indication of disconnector operation		red flag				
Remote contacts (RC)		YES				
Contact ratings		AC: 250V/0.5A; 125V/3A				
Terminal cross section		max. 1.5mm ²				
Remote terminal torque		0.25Nm				

Ordering information

U_c	150	275	320	385	440
Ordering code PROTEC DM 20/xxx (2+0)	508.029	508.031	508.033	508.113	508.035
Ordering code PROTEC DMR 20/xxx (2+0) (with remote contacts)	508.037	508.039	508.041	508.115	508.043
Ordering code Module PROTEC DM(R) 20/xxx	508.191	508.192	508.193	508.194	508.195

PROTEC DMG(R) 20 (2+0)



- Category IEC / EN / VDE: Class III / Type 3 / D
- Location of use: Sub-distribution boards
- Network systems: TN-S, TT
- Protection modes: L/N - PE
- Protective elements: MOV and GDT
- Surge discharge rating: $U_{oc} = 10kV$
- Housing: Modular design
- Complies with: IEC/EN 61643-11



Technical data

Type		PROTEC DMG(R) 20/320 (2+0)
Electrical characteristics		
Max. continuous operating voltage (AC/DC)	U_c	320/420V
Open circuit voltage of the combination wave generator	U_{oc}	10kV
Max. discharge current (8/20)	I_{max}	10kA per pole
Protection level	U_p (L/N-PE)	< 1.6kV
Follow current	I_{fi}	NO
Response time	t_A	< 100ns
Thermal protection		YES
Back-up fuse (if mains > 63A)		63A gL
Short-circuit withstand current	I_{sCCR}	10kA/50Hz
Mechanical characteristics		
Temperature range		-40°C +80°C
Terminal screw torque	Upper terminals	max. 2.0Nm
	Lower terminal	max. 3.0Nm
Terminal cross section	Upper terminals	6mm ² (solid) / 4mm ² (stranded)
	Lower terminal	35mm ² (solid) / 25mm ² (stranded)
Mounting		35mm DIN rail, EN 60715
Degree of protection		IP 20
Housing material		Thermoplastic; extinguishing degree UL 94 V-0
Indication of disconnector operation		red flag
Remote contacts (RC)		YES
Contact ratings		AC: 250V/0.5A; 125V/3A
Terminal cross section		max. 1.5mm ²
Remote terminal torque		0.25Nm

Ordering information

U_c	320
Ordering code PROTEC DMG 20/xxx (2+0)	508.021
Ordering code PROTEC DMGR 20/xxx (2+0) (with remote contacts)	508.027
Ordering code Module PROTEC DMG(R) 20/xxx	508.196

Dimensions, Internal configuration, Weight and Packaging

PROTEC D(R) 10/xxx

Dimensions

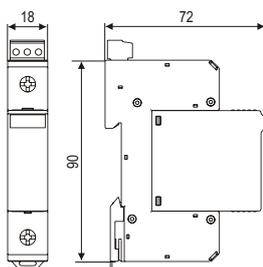

Internal configuration

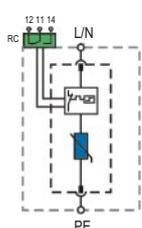

PROTEC D 10/xxx	150	275	320	385	440
Dimensions DIN 43880	1TE				
Weight per unit	124g	130g	130g	131g	132g
PROTEC DR 10/xxx	150	275	320	385	440
Dimensions DIN 43880	1TE				
Weight per unit	129g	135g	135g	136g	137g
Packaging dimensions (single unit)	108 x 74 x 24mm				
Min. packaging quantity	12 pcs.				

Module PROTEC D(R) 10/xxx

Dimensions

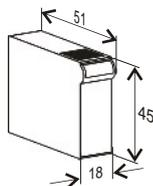

Internal configuration



Module PROTEC D(R) 10/xxx	150	275	320	385	440
Weight per unit	52g	58g	58g	59g	60g
Packaging dimensions	219 x 62 x 47mm				
Min. packaging quantity	12 pcs.				

PROTEC DM(R) 20/xxx (2+0)

Dimensions

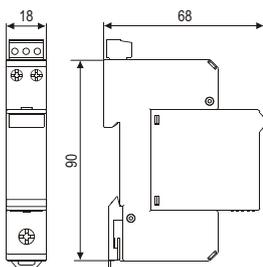

Internal configuration

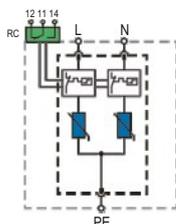

PROTEC DM 20/xxx (2+0)	150	275	320	385	440
Dimensions DIN 43880	1TE				
Weight per unit	136g	140g	150g	153g	155g
PROTEC DMR 20/xxx (2+0)	150	275	320	385	440
Dimensions DIN 43880	1TE				
Weight per unit	141g	145g	155g	158g	160g
Packaging dimensions (single unit)	108 x 74 x 24mm				
Min. packaging quantity	12 pcs.				

Module PROTEC DM(R) 20/xxx (2+0)

Dimensions

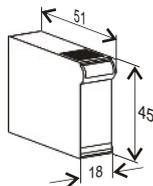

Internal configuration

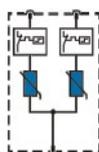

Module PROTEC DM(R) 20/xxx (2+0)	150	275	320	385	440
Weight per unit	69g	73g	83g	86g	88g
Packaging dimensions	219 x 62 x 47mm				
Min. packaging quantity	12 pcs.				

Dimensions, Internal configuration, Weight and Packaging

PROTEC DMG(R) 20/320 (2+0)

Dimensions

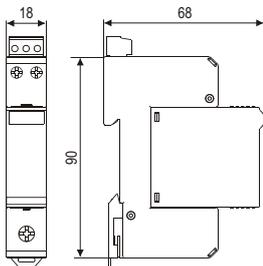

Internal configuration

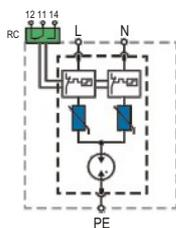

PROTEC DMG 20/320 (2+0)	
Dimensions DIN 43880	1TE
Weight per unit	118g
PROTEC DMGR 20/320 (2+0)	
Dimensions DIN 43880	1TE
Weight per unit	123g
Packaging dimensions (single unit)	108 x 74 x 24mm
Min. packaging quantity	12 pcs.

Module PROTEC DMG(R) 20/320 (2+0)

Dimensions

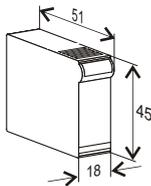

Internal configuration

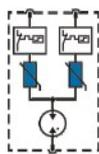

Module PROTEC DMG(R) 20/320 (2+0)	
Weight per unit	51g
Packaging dimensions	219 x 62 x 47mm
Min. packaging quantity	12 pcs.

PROLED 275 16A Series



- **Category IEC/EN/VDE:** Class III / Type 3 / C
- **Location of use:** Sub distribution board
- **Network systems:** TN-S, TT
- **Max. load current:** 16A AC
- **Protection modes:** L/N-PE
- **Protective elements:** MOV, GDT
- **Indication:** Red and green LED
- **No. of ports:** Two ports SPD
- **Complies with:** IEC/EN 61643-11



Technical data

Type	PROLED	
	275 (3+1) 16A	275 (4+0) 16A
Electrical characteristics		
Max. continuous operating voltage (AC/DC) at 50/60Hz	U_c	275V
Max. rated load current	I_L	16A
Open circuit voltage of the combination wave generator	U_{oc}	6kV
Protection level at U_{oc}	U_p (L-N)	850V
	U_p (L-PE)	/
Thermal protection		YES
Remote contacts		10A/230VAC
Back-up fuse (if mains > 16A)		16A gL
Mechanical characteristics		
Temperature range		-40°C +80°C
Terminal cross section		4mm ² (stranded)
Mounting		35mm DIN rail, EN 60715
Degree of protection		IP 20
Housing material		Thermoplastic; extinguishing degree UL 94 V-0
Indication of operation		Red and green LED

Ordering information

U_c	275 (3+1) 16A	275 (4+0) 16A
Ordering code PROLED	130 302	130 301

Dimensions

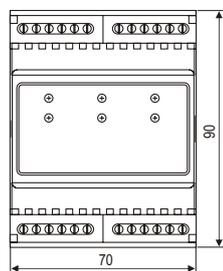

Internal configuration

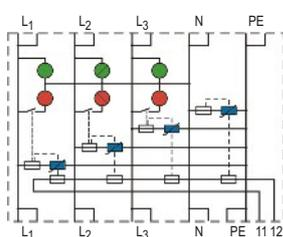

PROLED 275 (4+0) 16A

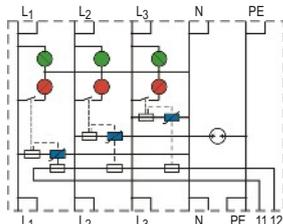

PROLED 275 (3+1) 16A

Dimensions, weight and packaging		
PROLED	275 (3+1) 16A	275 (4+0) 16A
Dimensions DIN 43890		4TE
Weight per unit		164g
Packaging dimensions (single unit)	109 x 76.5 x 78 mm	
Min. packaging quantity	3 pcs.	

MPE-MINI

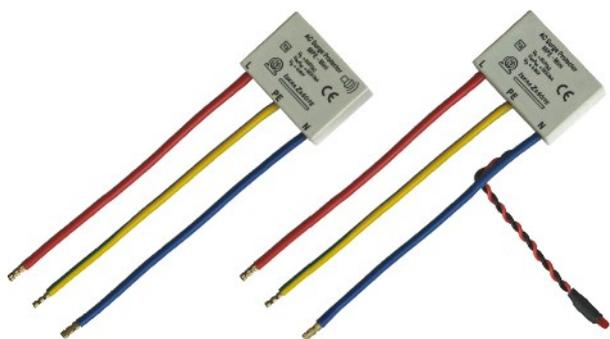

- Category IEC / EN / VDE: Class III / Type 3 / D
- Location of use: Cable ducts, wiring outlets
- Network systems: TN-S, TT
- Protection modes: L/N - PE
- Protective elements: MOV and GDT
- Surge discharge rating: $U_{oc} = 6kV$
- Fault indication: Buzzer; LED
- Complies with: IEC/EN 61643-11



Technical data

Type	MPE-MINI	MPE-MINI LED
Electrical characteristics		
Max. continuous operating voltage (AC/DC) at 50/60Hz	U_c	275V
Nominal load voltage	U_L	230V/50(60)Hz
Open circuit voltage of the combination wave generator	U_{oc}	6kV
Protection level	$U_p (L-N)$	800V
	$U_p (L/N-PE)$	1800V
Thermal protection		YES
Back-up fuse (if mains > 16A)		16A gL
Mechanical characteristics		
Temperature range		- 40°C + 80°C
Terminal cross section		1.5mm ² (stranded)
Mounting		Cable ducts
Degree of protection		IP 20
Housing material		Thermoplastic; extinguishing degree UL 94 V-0
Indication of disconnector operation	Buzzer	LED

Ordering information

U_c	275
Ordering code MPE-MINI	121 501
Ordering code MPE-MINI LED	130 331

Dimensions

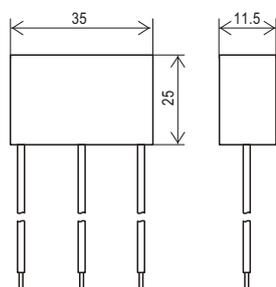

Internal configuration

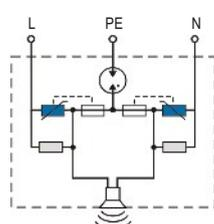

MPE-MINI

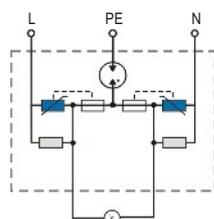

MPE-MINI LED

Dimensions, weight and packaging	
MPE-MINI	
Dimensions	35 x 25 x 12 mm
Weight per unit	52g
MPE-MINI LED	
Dimensions DIN 43880	35 x 25 x 12 mm
Weight per unit	52g
Min. packaging quantity	30 pcs.

ZE 200-PS



- **Category IEC / EN / VDE:** Class III / Type 3 / D
- **Location of use:** Power outlet
- **Network systems:** TN-S, TT
- **Protection modes:** L(N) - PE, L-N
- **Protective elements:** MOV and GDT
- **Surge discharge rating:** $U_{oc} = 6kV$
- **Indication:** Green and red light
- **Housing:** Compact design
- **Complies with:** IEC/EN 61643-11



Technical data

Type		ZE 200-PS
Electrical characteristics		
Max. continuous operating voltage (AC/DC) at 50/60Hz	U_c	275V
Nominal load voltage	U_L	230V/50(60)Hz
Open circuit voltage of the combination wave generator	U_{oc}	6kV
Protection level at U_{oc}	U_p (L-N)	< 1000V
	U_p (L/N-PE)	< 1500V
Response time	t_A (L-N)	< 25ns
	t_A (L/N-PE)	< 100ns
Thermal protection		YES
Back-up fuse (if mains > 16A)		16A gL
Mechanical characteristics		
Temperature range		-40°C +80°C
Connection		DIN 49 440-CE(7)III; DIN 49 441-CEE(7)IV; Crounding contact
Degree of protection		IP 20
Housing material		Thermoplastic; extinguishing degree UL 94 V-0
Indication of operation		Green and red light

Ordering information

U_c	275
Ordering code ZE 200-PS	121 532

Dimensions

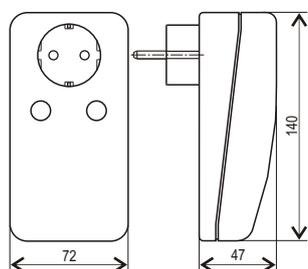

Internal configuration

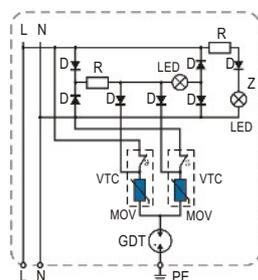

Dimensions, weight and packaging	
ZE 200-PS	
Dimensions	72 x 140 x 47 mm
Weight per unit	182g
Packaging dimensions (single unit)	95 x 150 x 90 mm
Min. packaging quantity	1 pc.

VTC 10



- Category IEC / EN / VDE: Class III / Type 3 / D
- Location of use: PCB
- Network systems: TN-S, TN-C, IT
- Protection modes: L/N - PE
- Protective element: MOV
- Surge discharge rating: $U_{OC} = 10kV$
- Fault indication: Visual
- Housing: Compact design
- Complies with: IEC/EN 61643-11



Technical data

Type		150	275	320	440
		VTC 10/xxx			
Electrical characteristics					
Max. continuous operating voltage (AC)	U_C	150V	275V	320V	440V
Open circuit voltage of the combination wave generator	U_{OC}	10kV			
Max. discharge current (8/20)	I_{max}	10kA			
Protection level	U_P	< 0.9kV	< 1.4kV	< 1.6kV	< 1.8kV
Follow current	I_{fi}	NO			
Response time	t_A	< 25ns			
Thermal protection		YES			
Back-up fuse (if mains > 16A)		16A gL			
Mechanical characteristics					
Temperature range		- 40°C + 80°C			
Mounting		On printed circuit board			
Degree of protection		IP 20			
Housing material		Thermoplastic; extinguishing degree UL 94 V-0			
Indication of disconnector operation		Visual			

Ordering information

U_C	150	275	320	440
Ordering code VTC 10/xxx	122 646	122 636	509 313	122 808

Dimensions

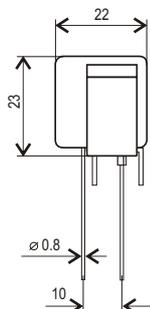

Internal configuration

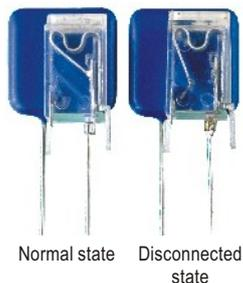
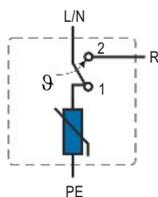

Dimensions, weight and packaging				
VTC 10/xxx	150	275	320	440
Weight per unit	6g	8g	12g	16g
Packaging dimensions	109 x 76.5 x 78 mm			
Min. packaging quantity	100 pcs.			

PROFILT D 8A



- **Category IEC/EN/VDE:** Class III / Type 3 / D
- **Location of use:** Sub distribution boards
- **Network systems:** TN-S, TT
- **Max. load current:** 8A
- **Protection modes:** L/N PE
- **Protective elements:** MOV, GDT, EMI Filter
- **Fault indication:** Red light
- **No. of ports:** Two port
- **Complies with:** IEC/EN 61643-11



Technical data

Type		PROFILT D 8A
Electrical characteristics		
Max. continuous operating voltage (AC/DC) at 50/60Hz	U_C	275V
Nominal load voltage at 50/60Hz	U_L	230V
Max. load current	I_L	8A
Open circuit voltage of the combination wave generator	U_{OC}	6kV
Protection level at U_{OC}	U_P (L-N)	< 1.0kV
Thermal protection		YES
Filtering		< 90dB@5MHz
Back-up fuse (if mains > 8A)		8A gL
Mechanical characteristics		
Temperature range		- 40°C + 80°C
Terminal screw torque		0.51Nm
Terminal cross section		2.5mm ² (stranded)
Mounting		35mm DIN rail, EN 60715
Degree of protection		IP 20
Housing material		Thermoplastic; extinguishing degree UL 94 V-0
Indication of disconnector operation		Red light

Ordering information

I_L	8A
Ordering code PROFILT 8A	130 061

Dimensions

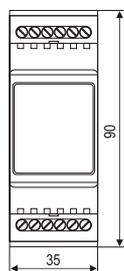

Internal configuration

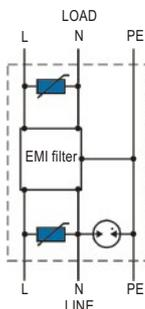

Dimensions, weight and packaging	
PROFILT D 8A	
Dimensions DIN 43880	2TE
Weight per unit	94g
Packaging dimensions (single unit)	109 x 76.5 x 41.5mm
Min. packaging quantity	7pcs.

PROFIL D



- **Category IEC/EN/VDE:** Class III / Type 3 / D
- **Location of use:** Sub distribution boards
- **Network systems:** TN-S, TT
- **Max. load current:** 30A
- **Protection modes:** L/N-PE
- **Protective elements:** MOV, GDT, EMI Filter
- **Fault indication:** Red light
- **No. of ports:** Two port
- **Complies with:** IEC/EN 61643-11



Technical data

Type	PROFIL D yy				
	10A	16A	25A	30A	
Electrical characteristics					
Max. continuous operating voltage (AC/DC) at 50/60Hz	U_C		275V		
Nominal load voltage at 50/60Hz	U_L		230V		
Max. load current	I_L	10A	16A	25A	30A
Open circuit voltage of the combination wave generator	U_{OC}		6kV		
Protection level at U_{OC}	$U_P (L-N)$		< 1.0kV		
Thermal protection	YES				
Filtering	< 70dB@1MHz				
Back-up fuse	10A gL	16A gL	25A gL	30A gL	
Mechanical characteristics					
Temperature range	- 40°C + 80°C				
Terminal cross section	25mm ² (stranded)				
Mounting	35mm DIN rail, EN 60715				
Degree of protection	IP 20				
Housing material	Thermoplastic; extinguishing degree UL 94 V-0				
Indication of disconnector operation	Red light				

Ordering information

I_L	10A	16A	25A	30A
Ordering code PROFIL D xxx	130 051	130 052	130 053	130 050

Dimensions

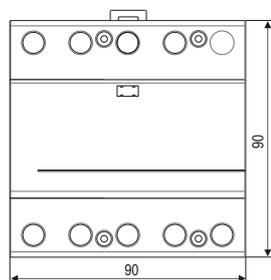

Internal configuration

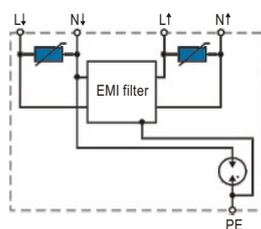

Dimensions, weight and packaging				
PROFIL D yy	10A	16A	25A	30A
Dimensions DIN 43880	5TE			
Weight per unit	420g			
Packaging dimensions (single unit)	109 x 76.5 x 96mm			
Min. packaging quantity	3 pcs.			

PROTEC DM(R) Series
PROTEC DMG(R) Series

Network connections

TN-S Network (Single-phase)

PROTEC DM(R) 20 (2+0)
 PROTEC DMG(R) 20 (2+0)

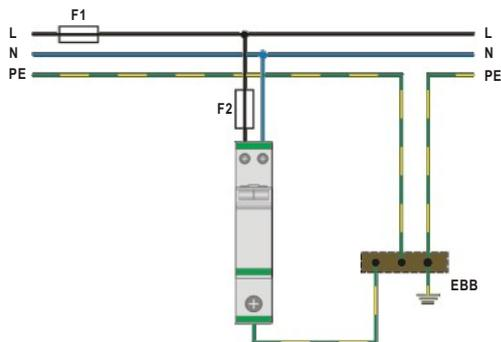

TN-S Network (Three-phase)

2x PROTEC DM(R) 20 (2+0)
 2x PROTEC DMG(R) 20 (2+0)

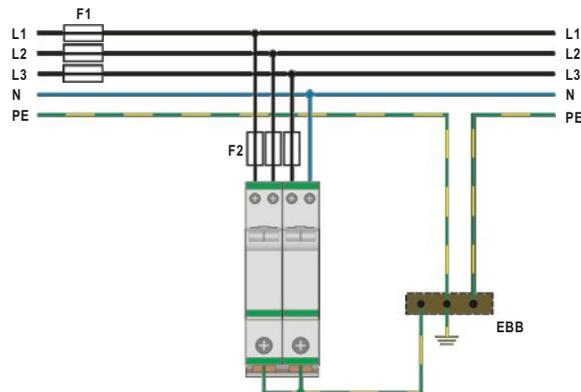

Back-up fuse

- $F1 > 63 \text{ A gL}$ → $F2 = 63 \text{ A gL}$
- $F1 \leq 63 \text{ A gL}$ → $F2$

Network connections

TN-S, TT Network

PROLED 275 16A

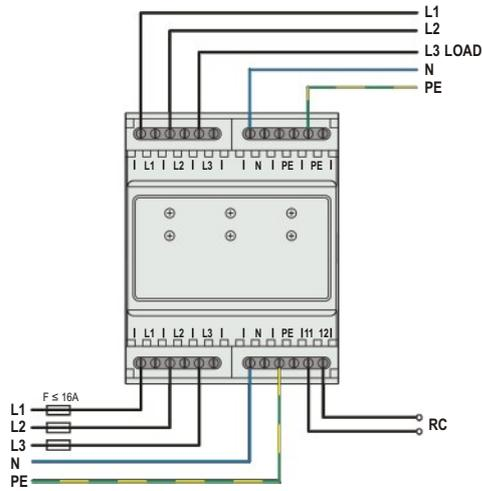

TN-S, TT Network

PROFIL D 8A

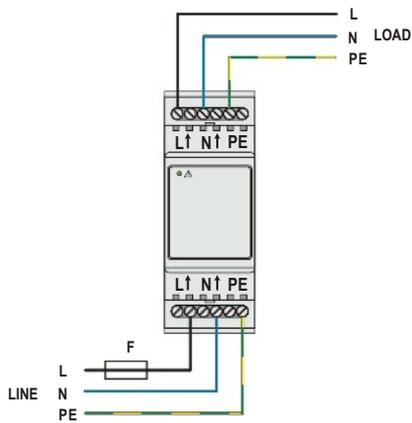

TN-S, TT Network

PROFIL D yy

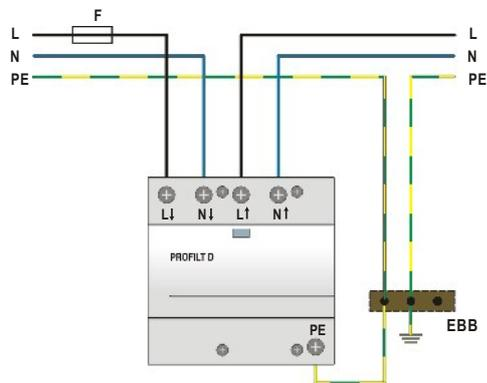

Modular and Compact SPD for DC Power Systems



Category IEC / EN / VDE:	Class I, II, III / Type 1, 2, 3 / B, C, D (IEC/EN 61643-1, 61643-11)
Category IEC / EN:	D1/C1/C2/C3 (IEC/EN 61643-21)
Location of use:	Sub-distribution boards, DC power systems, Low voltage data circuits
Protective elements:	MOV, GDT, diodes
Surge discharge ratings:	I_{max} up to 60kA, I_{imp} up to 10kA
Internal protection and safety:	Separate thermal disconnecter for each MOV
Complies with:	IEC/EN 61643-1, 61643-11, 61643-21

DC PROTEC B(R) 10/xx
DC PROTEC C(R) 40/xx
PROTEC C(R) 40/75
PROTEC CN(R) 40/75
PROTEC DMDR 20/xxx
VM-DC xx
SMH-PS xx

SPDs for DC power systems have been designed to meet the unique requirements of protection of DC power systems used for telecommunication and railway applications. It provides both, common and differential protection modes. Internal thermal disconnectors are used to eliminate the hazard of thermal runaway fault conditions.

DC PROTEC B(R) 10



- **Category IEC / EN / VDE:** Class I / Type 1 / B
- **Location of use:** Sub-distribution Boards
- **Protection modes:** (+) → PE, (-) → PE, (+) → (-)
- **Protective element:** MOV
- **Surge discharge rating:** $I_{imp} = 10\text{kA}$
- **Housing:** Compact design
- **Complies with:** IEC 61643-1



Technical data

Type	DC PROTEC B(R) 10/xx		
		24	48
Electrical characteristics			
Nominal operating voltage	U_n	24V	48V
Max. continuous operating voltage (DC)	U_c	30V	60V
Nominal discharge current (8/20)	I_n	20kA	20kA
Max. discharge current (8/20)	I_{max}	60kA	60kA
Impulse current (10/350)	I_{imp}	10kA	10kA
Protection level	U_p	< 0.6kV	< 0.6kV
Residual voltage at I_{imp}	U_{res}	< 0.3kV	< 0.3kV
Follow current	I_{fi}	NO	NO
Response time	t_A	< 25ns	< 25ns
Thermal protection		YES	YES
Short-circuit withstand current	I_{SCCR}	25kA / 50Hz	25kA / 50Hz
Mechanical characteristics			
Temperature range		- 40°C + 80°C	
Terminal screw torque		max. 3.0Nm	
Terminal cross section		35mm ² (solid) / 25mm ² (stranded)	
Mounting		35mm DIN rail, EN 60715	
Degree of protection		IP 20	
Housing material		Thermoplastic; extinguishing degree UL 94 V-0	
Indication of disconnecter operation		red flag	
Remote contacts (RC)		YES	
Contact ratings		AC: 250V/0.5A; 125V/3A	
Terminal cross section		max. 1.5mm ²	
Remote terminal torque		0.25Nm	

Ordering information

U_n	24	48
Ordering code DC PROTEC B 10/xx	510 598	510 600
Ordering code DC PROTEC BR 10/xx (with remote contacts)	510 599	510 601

Dimensions

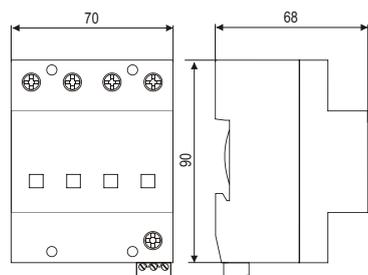

Internal configuration

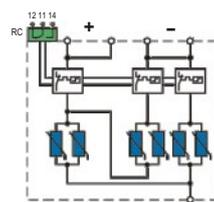

Dimensions, weight and packaging		
DC PROTEC B 10	24	48
Dimensions DIN 43880	4TE	
Weight per unit	246g	280g
DC PROTEC BR 10	24	48
Dimensions DIN 43880	4TE	
Weight per unit	251g	288g
Packaging dimensions (single unit)	109 x 76.5 x 78mm	
Min. packaging quantity	3 pcs.	

DC PROTEC C(R) 40



- **Category IEC / EN / VDE:** Class II / Type 2 / C
- **Location of use:** DC power systems
- **Protection modes:** (+) → PE, (-) → PE, (+) → (-)
- **Protective element:** MOV
- **Surge discharge rating:** $I_{max} = 40kA$
- **Housing:** Compact design
- **Complies with:** IEC 61643-1



Technical data

Type	DC PROTEC C(R) 40/xx		
		24	48
Electrical characteristics			
Nominal operating voltage	U_n	24V	48V
Max. continuous operating voltage (DC)	U_c	30V	60V
Nominal discharge current (8/20)	I_n	20kA	20kA
Max. discharge current (8/20)	I_{max}	40kA	40kA
Protection level	U_p (+) → (-) (+), (-) → PE	< 0.6kV	< 0.6kV
		< 1.5kV	< 1.5kV
Follow current	I_{fi}	NO	NO
Response time	t_A	< 25ns	< 25ns
Thermal protection		YES	YES
Short-circuit withstand current	I_{SCCR}	25kA / 50Hz	25kA / 50Hz
Mechanical characteristics			
Temperature range		- 40°C + 80°C	
Terminal screw torque		max. 3.0Nm	
Terminal cross section		35mm ² (solid) / 25mm ² (stranded)	
Mounting		35mm DIN rail, EN 60715	
Degree of protection		IP 20	
Housing material		Thermoplastic; extinguishing degree UL 94 V-0	
Indication of disconnecter operation		red flag	
Remote contacts (RC)		YES	
Contact ratings		AC: 250V/0.5A; 125V/3A	
Terminal cross section		max. 1.5mm ²	
Remote terminal torque		0.25Nm	

Ordering information

U_n	24	48
Ordering code DC PROTEC C 40/xx	510 564	510 566
Ordering code DC PROTEC CR 40/xx (with remote contacts)	510 565	510 567

Dimensions

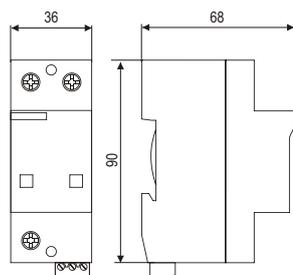

Internal configuration

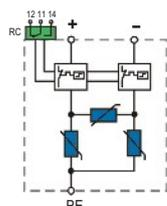

Dimensions, weight and packaging

DC PROTEC C 40	24	48
Dimensions DIN 43880	2TE	
Weight per unit	246g	280g
DC PROTEC CR 40	24	48
Dimensions DIN 43880	2TE	
Weight per unit	251g	288g
Packaging dimensions (single unit)	109 x 76.5 x 78mm	
Min. packaging quantity	3 pcs.	

PROTEC C(R) 40



- Category IEC / EN / VDE: Class II / Type 2 / C
- Location of use: Sub-distribution boards
- Protection modes: L/N- PE, L-PEN
- Protective element: MOV
- Surge discharge rating: $I_{max} = 40kA$
- Housing: Modular design
- Complies with: IEC/EN 61643-11



Technical data

Type		PROTEC C(R) 40/75	
Electrical characteristics			
Max. continuous operating voltage (AC/DC)	U_c		75/100V
Nominal discharge current (8/20)	I_n		20kA
Max. discharge current (8/20)	I_{max}		40kA
Protection level	U_p		< 0.6kV
Residual voltage at 5kA (8/20)	U_{res}		< 0.4kV
Follow current	I_{fi}		NO
Response time	t_A		< 25ns
Thermal protection			YES
Short-circuit withstand current	I_{SCCR}		25kA / 50Hz
Mechanical characteristics			
Temperature range			-40°C +80°C
Terminal screw torque			max. 3.0Nm
Terminal cross section			35mm ² (solid) / 25mm ² (stranded)
Mounting			35mm DIN rail, EN 60715
Degree of protection			IP 20
Housing material			Thermoplastic; extinguishing degree UL 94 V-0
Indication of disconnector operation			red flag
Remote contacts (RC)			YES
Contact ratings			AC: 250V/0.5A; 125V/3A
Terminal cross section			max. 1.5mm ²
Remote terminal torque			0.25Nm

Ordering information

U_c		75
Ordering code PROTEC C 40/75		50.0001
Ordering code PROTEC CR 40/75 (with remote contacts)		50.0011
Ordering code Module PROTEC C(R) 40/75		50.0216

Dimensions

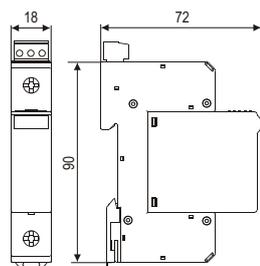

Internal configuration

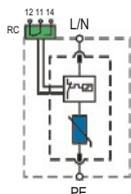

Dimensions, weight and packaging	
PROTEC C 40	75
Dimensions DIN 43880	1TE
Weight per unit	112g
PROTEC CR 40	75
Dimensions DIN 43880	1TE
Weight per unit	117g
Packaging dimensions (single unit)	108 x 74 x 24mm
Min. packaging quantity	12 pcs.
Module PROTEC C(R) 40	75
Weight per unit	44g
Packaging dimensions	219 x 62 x 47mm
Min. packaging quantity	12 pcs.

PROTEC CN(R) 40



- **Category IEC / EN / VDE:** Class II / Type 2 / C
- **Location of use:** Sub-distribution boards
- **Protection modes:** L/N- PE, L-PEN
- **Protective element:** MOV
- **Surge discharge rating:** $I_{max} = 40kA$
- **Housing:** Compact design
- **Complies with:** IEC/EN 61643-11



Technical data

Type	PROTEC CN(R) 40/75
------	--------------------

Electrical characteristics

Max. continuous operating voltage (AC/DC)	U_c	75/100V
Nominal discharge current (8/20)	I_n	20kA
Max. discharge current (8/20)	I_{max}	40kA
Protection level	U_p	< 0.6kV
Residual voltage at 5kA (8/20)	U_{res}	< 0.4kV
Follow current	I_{fi}	NO
Response time	t_A	< 25ns
Thermal protection		YES
Short-circuit withstand current	I_{SCCR}	25kA / 50Hz

Mechanical characteristics

Temperature range	-40°C +80°C
Terminal screw torque	max. 3.0Nm
Terminal cross section	35mm ² (solid) / 25mm ² (stranded)
Mounting	35mm DIN rail, EN 60715
Degree of protection	IP 20
Housing material	Thermoplastic; extinguishing degree UL 94 V-0
Indication of disconnector operation	red flag
Remote contacts	YES
Contact ratings	AC: 250V/0.5A; 125V/3A
Terminal cross section	max. 1.5mm ²
Remote terminal torque	0.25Nm

Ordering information

U_c	75
Ordering code PROTEC CN 40/75	507.001
Ordering code PROTEC CNR 40/75 (with remote contacts)	507.011

Dimensions

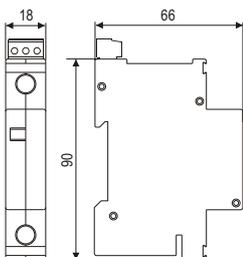

Internal configuration

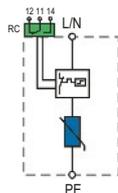

Dimensions, weight and packaging

PROTEC CN 40	75
Dimensions DIN 43880	1TE
Weight per unit	127g
PROTEC CNR 40	75
Dimensions DIN 43880	1TE
Weight per unit	132g
Packaging dimensions (single unit)	108 x 74 x 24mm
Min. packaging quantity	12 pcs.

PROTEC DMDR 20



- **Category IEC / EN / VDE:** Class III / Type 3 / D
- **Location of use:** DC power systems
- **Protection modes:** L/N - PE
- **Protective element:** MOV + GDT
- **Surge discharge ratings:** I_{max} up to 10kA
- **Housing:** Modular design
- **Complies with:** IEC/EN 61643-11



Technical data

Type		24	48	60	120
Electrical characteristics					
Nominal operating voltage	U_n	24VAC	48VAC	60VAC	120VAC
Max. continuous operating voltage	U_c	34VAC/44VDC	60VAC/DC	75VAC/DC	150VAC/DC
Open circuit voltage of the combination wave generator	U_{oc}	4kV	4kV	6kV	6kV
Nominal discharge current (8/20μs)	I_n	1.2kA	2.5kA	2.5kA	4kA
Max. discharge current (8/20μs)	I_{max}	3kA	6kA	6kA	10kA
Protection level	U_p (L-N)	< 180V	< 370V	< 400V	< 600V
	(L-PE/N-PE)	< 550V	< 650V	< 700V	< 850V
Response time of overvoltage protection	t_A (L-N)			< 25ns	
	(L-PE/N-PE)			< 100ns	
Thermal protection				YES	
Mechanical characteristics					
Temperature range				-40°C ... +80°C	
Terminal cross section				Multi-strand to 6 mm ²	
Terminal screw torque				max. 2Nm	
Degree of protection				IP 20	
Housing material				Thermoplastic; gray, extinguishing degree UL 94 V-0	
Mounting				35mm DIN rail, EN 60715	

Ordering information

U _n	24	48	60	120
Ordering code PROTEC DMDR 20/xx	515 051	515 053	515 054	515 055
Ordering code Module PROTEC DMDR 20/xx	515 086	515 087	515 088	515 089

Dimensions

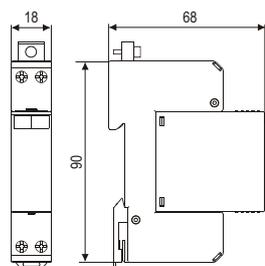

Internal configuration

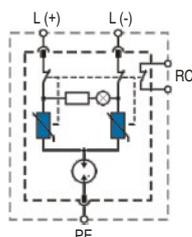

Dimensions, weight and packaging				
PROTEC DMDR 20/xx	24	48	60	120
Dimensions DIN 43880	1TE			
Weight per unit	96g	96g	96g	96g
Packaging dimensions (single unit)	108 x 74 x 24mm			
Min. packaging quantity	12 pcs.			
Module PROTEC DMDR 20/xx	24	48	60	120
Weight per unit	99g	99g	99g	99g
Packaging dimensions	219 x 62 x 47mm			
Min. packaging quantity	12 pcs.			

VM-DC



- IEC category / EN type: D1/C1/C2/C3
- Location of use: Low voltage data circuits
- Coarse protection: 3 terminal GDT
- Series resistance: 0.1Ω
- Surge discharge ratings: $I_n = 10\text{kA}$, $I_{max} = 20\text{kA}$, $I_{imp} = 2.5\text{kA}$
- Housing: Modular design
- No. of ports: Two port
- Complies with: IEC 61643-21



Technical data

Type		12V	VM-DC xx	24V
Electrical characteristics				
Number of protected pairs			1 (2 conductors)	
Nominal operating voltage	U_n	12V _{DC}		24V _{DC}
Max. continuous operating voltage	U_c	15V _{DC}		28V _{DC}
Rated spark overvoltage	(0, 12/24V - PG)	184V - 276V		184V - 276V
	(0 - 12/24V)	16V - 20V		30V - 36V
Rated load current at 25°C	I_L	10A		10A
Nominal discharge current (8/20μs)	I_n	10kA		10kA
Max. discharge current (8/20μs)	I_{max}	20kA		20kA
Impulse current (10/350)	I_{imp}	2.5kA		2.5kA
Residual voltage at 5 kA (8/20μs)		< 32V (0.12V)		< 60V (0.24V)
Response time of overvoltage protection	t_A	< 1ns		< 1ns
Thermal protection		YES		YES
Insulation resistance of the protection		≥ 15MΩ		≥ 28MΩ
Serial resistance	R	< 0.1Ω		< 0.1Ω
Transverse capacitance	C	< 1nF		< 3nF
Mechanical characteristics				
Temperature range			-40°C ... +80°C	
Terminal cross section			Multi-strand to 6 mm ²	
Terminal screw torque			max. 2Nm	
Degree of protection			IP 20	
Housing material			Thermoplastic; yellow, extinguishing degree V-O	
Mounting			35mm DIN rail, EN 60715	

Ordering information

U_n	12V	24V
Ordering code VM-DC xx	7035.02	7035.04
Ordering code Module VM-DC xx	7035.01	7035.03

Dimensions

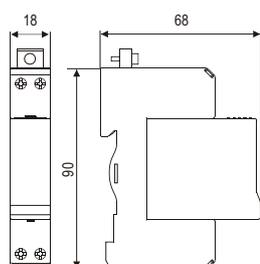

Internal configuration

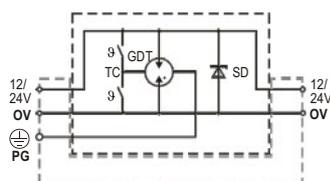

Dimensions, weight and packaging		
VM-DC xx	12V	24V
Dimensions DIN 43880	1TE	
Weight per unit	90g	90g
Packaging dimensions (single unit)	108 x 74 x 24mm	
Min. packaging quantity	12 pcs.	
Module VM-DC xx	12V	24V
Weight per unit	30g	30g
Packaging dimensions	219 x 62 x 47mm	
Min. packaging quantity	12 pcs.	

SMH-PS



- IEC category / EN type: C1/C2/C3
- Location of use: Low voltage data circuits
- Coarse protection: MOV
- Series inductance: 10 - 14μH
- Surge discharge ratings: $I_n = 10kA, I_{max} = 20kA$
- Housing: Modular design
- No. of ports: Two port
- Complies with: IEC 61643-21



Technical data

Type		12V	SMH-PS xx 24V	48V
Electrical characteristics				
Number of protected pairs			1 (2 conductors)	
Nominal operating voltage	U_n	12V _{DC}	24V _{DC}	48V _{DC}
Max. continuous operating voltage	U_c	15V _{DC}	28V _{DC}	52V _{DC}
Rated spark overvoltage	(1, 2 - PG)	90V - 110V	90V - 110V	90V - 110V
	(1, 2)	16V - 20V	30V - 36V	57V - 69V
Rated load current at 25°C	I_L	4A	4A	4A
Nominal discharge current (8/20μs)	I_n	10kA	10kA	10kA
Max. discharge current (8/20μs)	I_{max}	20kA	20kA	20kA
Residual voltage at 5 kA (8/20μs)	U_p	< 32V	< 60V	< 135V
Response time of overvoltage protection	t_A	< 1ns	< 1ns	< 1ns
Thermal protection		Thermal disconnection		
Insulation resistance of the protection		≥ 15MΩ	≥ 28MΩ	≥ 52MΩ
Serial inductivity	L	10 - 14μH	10 - 14μH	10 - 14μH
Transverse capacitance	C	< 5nF	< 3nF	< 1.5nF
Mechanical characteristics				
Temperature range		- 40°C ... + 80°C		
Terminal cross section		Multi-strand to 4 mm ²		
Terminal screw torque		0.5Nm		
Degree of protection		IP 20		
Housing material		Thermoplastic; gray, extinguishing degree V-O		
Mounting		35mm DIN rail, EN 60715		

Ordering information

U_n	12V	24V	48V
Ordering code SMH-PS xx	7081.20	7081.21	7081.22
Ordering code Module SMH-PS xx	7081.25	7081.26	7081.27

Dimensions

Internal configuration

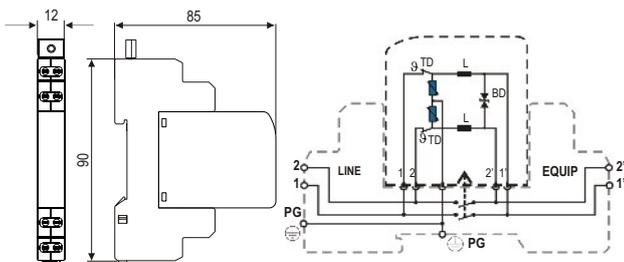

Dimensions, weight and packaging			
SMH-PS xx	12V	24V	48V
Dimensions DIN 43880		12mm	
Weight per unit	66g	66g	64g
Packaging dimensions (single unit)	102 x 87 x 15 mm		
Min. packaging quantity	15 pcs.		
Module SMH-PS xx	12V	24V	48V
Weight per unit	22g	22g	21g
Packaging dimensions	102 x 87 x 15 mm		
Min. packaging quantity	15 pcs.		

Class I, II SPD for Photovoltaic Systems



Category IEC / EN / VDE:

Location of use:

Protection modes:

Protective element:

Surge discharge rating:

Safety:

Internal protection:

Complies with:

Class I, II / Type 1, 2 / B, C

Photovoltaic systems - PV module side

(+) → PE, (-) → PE, (+) → (-)

High energy MOV and GDT

$I_{imp} = 12.5kA$; I_{max} up to 40kA

Ground fault immunity, ground fault withstand

Separate thermal disconnecter for each MOV

EN 50539-11, UL 1449 3rd Ed.

The new SAFETEC PV TCG* series of surge protective devices (SPDs):

- Are highly reliable - controlled disconnection, arc-quenching
- Have no risk of fire in PV system - arc prevention function using rotating disc
- Are safer - controlled behaviour even when surge ratings are exceeded
- Have longer life - protection against ageing
- Have up to 20 years warranty

SAFETEC B(R) PV TCG Series:

SAFETEC B(R) 12.5/xxxx PV TCG

SAFETEC B(R) 12.5/xxxx Y PV TCG

SAFETEC B(R) PV TCG series provides common and differential protection mode.

Patented TCG technology provides high level of reliability and safety in solar PV systems.

A unique indicator monitors all disconnectors and brings up a common status flag if any of current branches fails.

SAFETEC C(R) PV Series:

SAFETEC C(R) xxxx PV

SAFETEC C(R) xxxx Y PV

TCG technology enables high immunity in the case of ground faults in solar PV systems.

TCG technology means no leakage current.

Combination of GDT + MOV prevents intensive ageing of components, thereby prolonging the SPDs life-span.

SAFETEC C(R) xxxx PV UL

Selection of SPDs should adhere to national and international standards.

PV PROTEC C(R) 40/xxxx

*TCG - Thermal control function without leakage current
TC - Thermal control function

SAFETEC B(R) 12.5 PV TCG

- **Category IEC / EN:** Class I, II / Type 1, 2 / B, C
- **Location of use:** Photovoltaic systems - PV module side
- **Protection modes:** (+) → PE, (-) → PE, (+) → (-)
- **Protective elements:** High energy MOV and GDT
- **Surge discharge rating:** $I_{imp} = 12.5kA$
- **Safety:** Ground fault immunity
- **Leakage current:** NO leakage current (TCG)
- **Housing:** Compact design
- **Complies with:** EN 50539-11, UL 1449 3rd Ed.

Technical data

Type	SAFETEC B(R) 12.5/xxxx PV TCG			
	300	600	1000	
Electrical characteristics				
Max. continuous operating voltage (DC)	U_{CPV}^*	300V	600V	1000V
Nominal discharge current (8/20)	$I_n (+) \rightarrow PE / (-) \rightarrow PE$		12.5kA	
Max. discharge current (8/20)	$I_{max} (+) \rightarrow PE / (-) \rightarrow PE$		40kA	
Impulse current (10/350)	$I_{imp} (+) \rightarrow PE / (-) \rightarrow PE$		12.5kA	
Short circuit withstand	I_{SCPV}		1000A	
Specific energy			39kJ/Ω	
Charge			6.25As	
Protection level	U_p	< 1.1kV	< 1.6kV	< 2.4kV
Residual voltage at 5kA (8/20)	U_{res}	< 0.8kV	< 1.4kV	< 2.1kV
Follow current	I_{fi}		NO	
Residual current	I_{PE}		NO	
Response time	t_A		< 25ns	
Thermal protection			YES	
Ground fault immunity (DC)		600V	1200V	2000V
Mechanical characteristics				
Temperature range		- 40°C ... + 80°C		
Terminal screw torque		max. 3.0Nm		
Terminal cross section		35mm ² (solid) / 25mm ² (stranded)		
Mounting		35mm DIN rail, EN 60715		
Degree of protection		IP 20		
Housing material		Thermoplastic; extinguishing degree UL 94 V-0		
Indication of disconnector operation		red flag		
Remote contacts (RC)		YES		
Contact ratings		AC: 250V/0.5A; 125V/3A		
Terminal cross section		max. 1.5mm ²		
Remote terminal torque		0.25Nm		

* $U_{CPV} \geq 1.2 \cdot U_{OCSTC}$ → open circuit voltage under standard test condition

Ordering information

U_{CPV}	300	600	1000
Ordering code SAFETEC B 12.5/xxxx PV TCG	54.0096	54.0098	54.0102
Ordering code SAFETEC BR 12.5/xxxx PV TCG (with remote contacts)	54.0097	54.0099	54.0103

TC solution available on request

SAFETEC B(R) 12.5 Y PV TCG

- **Category IEC / EN:** Class I, II / Type 1, 2 / B, C
- **Location of use:** Photovoltaic systems - PV module side
- **Protection modes:** (+) → PE, (-) → PE, (+) → (-)
- **Protective elements:** High energy MOV and GDT
- **Surge discharge rating:** $I_{imp} = 12.5kA$
- **Safety:** Ground fault immunity
- **Leakage current:** NO leakage current (TCG)
- **Housing:** Compact design
- **Complies with:** EN 50539-11, UL 1449 3rd Ed.

Technical data

Type		SAFETEC B(R) 12.5/xxxx Y PV TCG			
		600	1000	1200	1500
Electrical characteristics					
Max. continuous operating voltage (DC)	U_{CPV}^*	600V	1000V	1200V	1500V
Nominal discharge current (8/20)	$I_n (+) \rightarrow PE / (-) \rightarrow PE / (+) \rightarrow (-)$			12.5kA	
Max. discharge current (8/20)	$I_{max} (+) \rightarrow PE / (-) \rightarrow PE / (+) \rightarrow (-)$			40kA	
Impulse current (10/350)	$I_{imp} (+) \rightarrow PE / (-) \rightarrow PE / (+) \rightarrow (-)$			12.5kA	
Short circuit withstand	I_{SCPV}			1000A	
Specific energy				39kJ/Ω	
Charge				6.25As	
Protection level	U_p	< 1.8kV	< 3.0kV	< 3.6kV	< 4.2kV
Residual voltage at 5kA (8/20)	U_{res}	< 1.5kV	< 2.6kV	< 3.2kV	< 3.8kV
Follow current	I_{fi}			NO	
Residual current	I_{PE}			NO	
Response time	t_A			< 25ns	
Thermal protection				YES	
Ground fault immunity (DC)		1200V	2000V	2400V	3000V
Mechanical characteristics					
Temperature range				- 40°C ... + 80°C	
Terminal screw torque				max. 3.0Nm	
Terminal cross section				35mm ² (solid) / 25mm ² (stranded)	
Mounting				35mm DIN rail, EN 60715	
Degree of protection				IP 20	
Housing material				Thermoplastic; extinguishing degree UL 94 V-0	
Indication of disconnector operation				red flag	
Remote contacts (RC)				YES	
Contact ratings				AC: 250V/0.5A; 125V/3A	
Terminal cross section				max. 1.5mm ²	
Remote terminal torque				0.25Nm	

* $U_{CPV} \geq 1.2 \cdot U_{OCSTC}$ → open circuit voltage under standard test condition

Ordering informations

U_{CPV}	600	1000	1200	1500
Ordering code SAFETEC B 12.5/xxxx Y PV TCG	54.0100	54.0104	54.0106	54.0108
Ordering code SAFETEC BR 12.5/xxxx Y PV TCG (with remote contacts)	54.0101	54.0105	54.0107	54.0109

TC solution available on request



Dimensions, Internal configuration, Weight, Packaging, Connections

SAFETEC B(R) 12.5/xxxx PV TCG

Dimensions

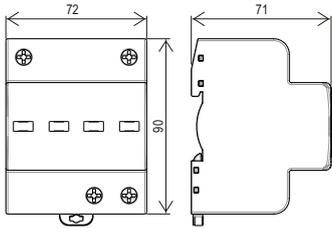

Internal configuration

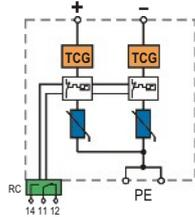

SAFETEC B 12.5/xxxx PV TCG	300	600	1000
Dimensions DIN 43880		4TE	
Weight per unit	440g	460g	800g
SAFETEC BR 12.5/xxxx PV TCG	300	600	1000
Dimensions DIN 43880		4TE	
Weight per unit	445g	465g	805g
Packaging dimensions (single unit)	109 x 76.5 x 78mm		
Min. Packaging quantity	3 pcs.		

SAFETEC B(R) 12.5/xxxx Y PV TCG

Dimensions

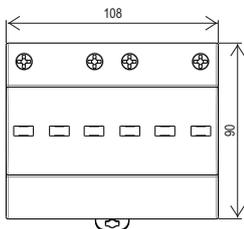

Internal configuration

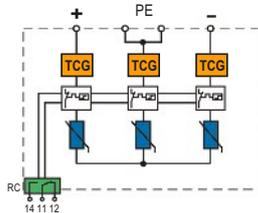

SAFETEC B 12.5/xxxx Y PV TCG	600	1000	1200	1500
Dimensions DIN 43880		6TE		
Weight per unit	590g	630g	1100g	1160g
SAFETEC BR 12.5/xxxx Y PV TCG	600	1000	1200	1500
Dimensions DIN 43880		6TE		
Weight per unit	600g	640g	1110g	1170g
Packaging dimensions (single unit)	109 x 110 x 78mm			
Min. Packaging quantity	2 pcs.			

SAFETEC B(R) 12.5/xxxx PV TCG

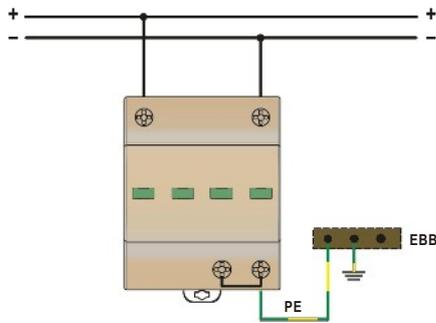

SAFETEC B(R) 12.5/xxxx Y PV TCG

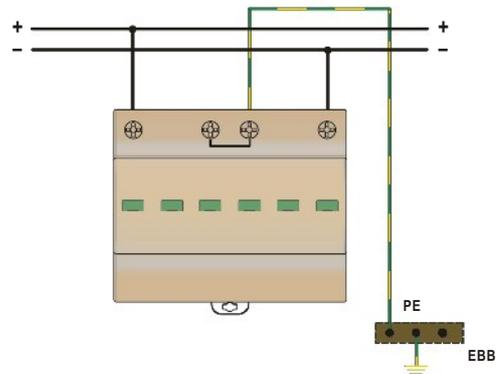

SAFETEC C(R) PV



- Category IEC / EN / VDE: Class II / Type 2 / C
- Location of use: Photovoltaic systems - PV module side
- Protection modes: (+) → PE, (-) → PE, (+) → (-)
- Protective elements: MOV and GDT
- Surge discharge rating: I_{max} up to 40kA
- Safety: Ground fault withstand
- Housing: Modular design
- Complies with: EN 50539-11



Technical data

Type		75	SAFETEC C(R) xxxx PV 300	600	1000
Electrical characteristics					
Max. continuous operating voltage (DC)	$U_{CPV}^{* (+) \rightarrow PE / (-) \rightarrow PE}$	75V	300V	600V	1000V
Nominal discharge current (8/20)	$I_n (+) \rightarrow PE / (-) \rightarrow PE$	10kA	20kA	20kA	12.5kA
Max. discharge current (8/20)	$I_{max} (+) \rightarrow PE / (-) \rightarrow PE$	20kA	40kA	40kA	25kA
Short-circuit withstand	I_{SCP}			1000A	
Protection level	$U_p (+) \rightarrow PE / (-) \rightarrow PE$	< 0.8kV	< 1.5kV	< 2.3kV	< 2.8kV
Residual voltage at 5kA (8/20)	U_{res}	< 0.6kV	< 1.1kV	< 1.6kV	< 2.2kV
Follow current	I_{fi}			NO	
Response time	t_A			< 25ns	
Thermal protection				YES	
Ground fault withstand (DC)		120V	450V	900V	1500V
Mechanical characteristics					
Temperature range				- 40°C ... + 80°C	
Terminal screw torque				max. 3.0Nm	
Terminal cross section				35mm ² (solid) / 25mm ² (stranded)	
Mounting				35mm DIN rail, EN 60715	
Degree of protection				IP 20	
Housing material				Thermoplastic; extinguishing degree UL 94 V-0	
Indication of disconnector operation				red flag	
Remote contacts (RC)				YES	
Contact ratings				AC: 250V/0.5A; 125V/3A	
Terminal cross section				max. 1.5mm ²	
Remote terminal torque				0.25Nm	

* $U_{CPV} \geq 1.2 \cdot U_{OCSTC}$ → open circuit voltage under standard test condition

Ordering information

U_{CPV}	75	300	600	1000
Ordering code SAFETEC C xxxx PV	516.040	516.042	516.044	516.046
Ordering code SAFETEC CR xxxx PV (with remote contacts)	516.041	516.043	516.045	516.047
Ordering code Module SAFETEC C(R) xxxx PV	516.050	516.051	516.052	516.053

SAFETEC C(R) Y PV



- Category IEC / EN / VDE: Class II / Type 2 / C
- Location of use: Photovoltaic systems - PV module side
- Protection modes: (+) → PE, (-) → PE, (+) → (-)
- Protective elements: MOV and GDT
- Surge discharge rating: I_{max} up to 40kA
- Safety: Ground fault withstand
- Housing: Modular design
- Complies with: EN 50539-11



Technical data

Type		SAFETEC C(R) xxxxY PV		
		1000	1200	1500
Electrical characteristics				
Max. continuous operating voltage (DC)	U_{CPV}^* (+)→PE(-)→PE	1000V	1200V	1500V
	U_{CPV} per module	500V	600V	750V
Nominal discharge current (8/20)	I_n (+)→PE(-)→PE/(+)→(-)	20kA	20kA	12.5kA
Max. discharge current (8/20)	I_{max} (+)→PE(-)→PE/(+)→(-)	40kA	40kA	25kA
Short-circuit withstand	I_{SCP}		1000A	
Protection level	U_p (+)→PE(-)→PE/(+)→(-)	< 4.2kV	< 4.6kV	< 5.0kV
Residual voltage at 5kA (8/20)	U_{res}	< 3.2kV	< 3.6kV	< 4.0kV
Follow current	I_{fi}		NO	
Response time	t_A		< 25ns	
Thermal protection			YES	
Ground fault withstand (DC)		1500V	1800V	2400V
Mechanical characteristics				
Temperature range		- 40°C ... + 80°C		
Terminal screw torque		max. 3.0Nm		
Terminal cross section		35mm ² (solid) / 25mm ² (stranded)		
Mounting		35mm DIN rail, EN 60715		
Degree of protection		IP 20		
Housing material		Thermoplastic; extinguishing degree UL 94 V-0		
Indication of disconnector operation		red flag		
Remote contacts (RC)		YES		
Contact ratings		AC: 250V/0.5A; 125V/3A		
Terminal cross section		max. 1.5mm ²		
Remote terminal torque		0.25Nm		

* $U_{CPV} \geq 1.2 \cdot U_{OCSTC}$ → open circuit voltage under standard test condition

Ordering information

U_{CPV}	1000	1200	1500
Ordering code SAFETEC C xxxx Y PV	516.242	516.048	516.271
Ordering code SAFETEC CR xxxx Y PV (with remote contacts)	516.243	516.049	516.272
Ordering code Module SAFETEC C(R) xxxx Y PV	516.244	516.054	516.273

Dimensions, Internal configuration, Weight and Packaging

SAFETEC C(R) xxxx PV

Dimensions

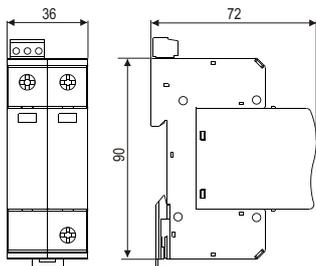

Internal configuration

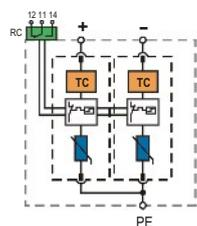

SAFETEC C xxxx PV	75	300	600	1000
Dimensions DIN 43880	2TE			
Weight per unit	246g	280g	290g	299g
SAFETEC CR xxxx PV	75	300	600	1000
Dimensions DIN 43880	2TE			
Weight per unit	251g	288g	298g	307g
Packaging dimensions (single unit)	109 x 76.5 x 41.5mm			
Min. packaging quantity	7 pcs.			

Module SAFETEC C(R) xxxx PV

Dimensions

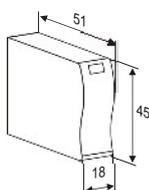

Internal configuration

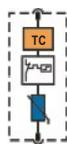

Module SAFETEC C(R) xxxx PV	75	300	600	1000
Weight per unit	45g	68g	74g	78g
Packaging dimensions	219 x 62 x 47mm			
Min. packaging quantity	12 pcs.			

SAFETEC C(R) xxxx Y PV

Dimensions

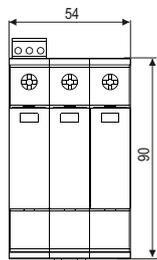

Internal configuration

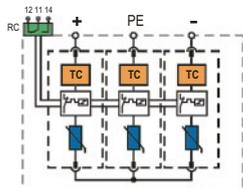

SAFETEC C xxxx Y PV	1000	1200	1500
Dimensions DIN 43880	3TE		
Weight per unit	396g	390g	400g
SAFETEC CR xxxx Y PV	1000	1200	1500
Dimensions DIN 43880	3TE		
Weight per unit	402g	396g	406g
Packaging dimensions (single unit)	109 x 76.5 x 60mm		
Min. packaging quantity	5 pcs.		

Module SAFETEC C(R) xxxx Y PV

Dimensions

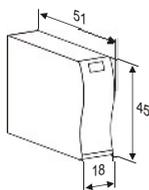

Internal configuration

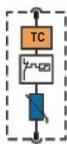

Module SAFETEC C(R) xxxx Y PV	1000	1200	1500
Weight per unit	74g	74g	76g
Packaging dimensions	219 x 62 x 47mm		
Min. packaging quantity	12 pcs.		

SAFETEC C(R) PV Series

Connections

SAFETEC C(R) xxxx PV

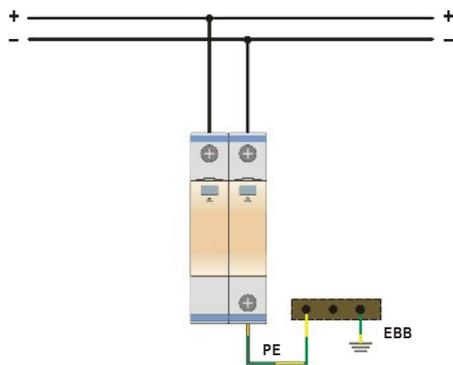

SAFETEC C(R) xxxx Y PV

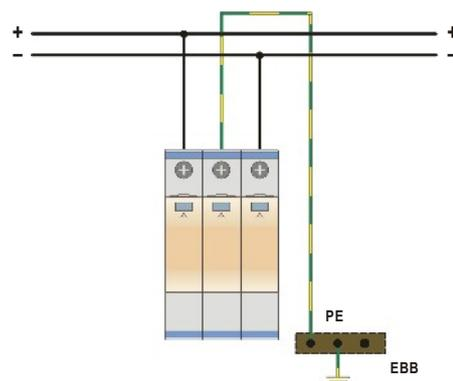



SAFETEC C(R) PV (2+0) UL



- **Classification** UL 1449 3rd ed.: Type 2
- **Location of use:** Photovoltaic systems - PV module side
- **Protection modes:** (+) → PE (G), (-) → PE (G), (+) → (-)
- **Protective elements:** MOV and GDT
- **Surge discharge rating:** I_{max} up to 50kA
- **Safety:** Ground fault withstand
- **Housing:** Modular design
- **Complies with:** UL 1449 3rd Ed.



Technical data

Type	SAFETEC C(R) xxxx PV (2+0) UL			
	300	600	1000	
Electrical characteristics				
Max. continuous operating voltage (DC)	MCOV	300V	600V	1000V
Nominal discharge current (8/20) per mode of protection	I_n	20kA	20kA	10kA
Max. discharge current (8/20) per mode of protection	I_{max}	50kA	50kA	20kA
Voltage protection rating per UL 1449 3rd ed.	VPR	1.5kV	2.0kV	4.0kV
Short circuit current rating	SCCR		200kA	
Follow current	I_{fi}		NO	
Response time	t_A		< 25ns	
Thermal protection			YES	
Ground fault withstand (DC)		450V	900V	1200V
Mechanical characteristics				
Terminal screw torque		max. 3.0Nm		
Temperature range		- 40°C + 80°C		
Terminal cross section		35mm ² (solid) / 25mm ² (stranded)		
Mounting		35mm DIN rail, EN 60715		
Degree of protection		IP 20		
Housing material		Thermoplastic; extinguishing degree UL 94 V-0		
Indication of disconnector operation		red flag		
Remote contacts (RC)		YES		
Contact ratings		AC: 250V/0.5A; 125V/3A		
Terminal cross section		max. 1.5mm ²		
Remote terminal torque		0.25Nm		

Ordering information

MCOV	300	600	1000
Ordering code SAFETEC C xxxx PV (2+0) UL	516.105	516.107	516.199
Ordering code SAFETEC CR xxxx PV (2+0) UL (with remote contacts)	516.106	516.108	516.200
Ordering code Module SAFETEC C(R) xxxx PV UL	516.207	516.208	516.209



SAFETEC C(R) PV (3+0) UL



- Classification UL 1449 3rd ed.: Type 2
- Location of use: Photovoltaic systems - PV module side
- Protection modes: (+) → PE (G), (-) → PE (G), (+) → (-)
- Protective elements: MOV and GDT
- Surge discharge rating: I_{max} up to 50kA
- Safety: Ground fault withstand
- Housing: Modular design
- Complies with: UL 1449 3rd Ed.



Technical data

Type		300	600	1000	1200	1500
Electrical characteristics						
Max. continuous operating voltage (DC)	MCOV	300V	600V	1000V	1200V	1500V
Nominal discharge current (8/20) per mode of protection	I_n	20kA	20kA	20kA	20kA	10kA
Max. discharge current (8/20) per mode of protection	I_{max}	50kA	50kA	50kA	50kA	20kA
Voltage protection rating per UL 1449 3rd ed.	VPR	2.4kV	3.0kV	4.0kV	4.0kV	5.0kV
Short circuit current rating	SCCR	200kA				
Follow current	I_{fi}	NO				
Response time	t_A	< 25ns				
Thermal protection		YES				
Ground fault withstand (DC)		450V	900V	1500V	1800V	2400V
Mechanical characteristics						
Terminal screw torque		max. 3.0Nm				
Temperature range		- 40°C + 80°C				
Terminal cross section		35mm ² (solid) / 25mm ² (stranded)				
Mounting		35mm DIN rail, EN 60715				
Degree of protection		IP 20				
Housing material		thermoplastic; extinguishing degree UL 94 V-0				
Indication of disconnecter operation		red flag				
Remote contacts (RC)		YES				
Contact ratings		AC: 250V/0.5A; 125V/3A				
Terminal cross section		max. 1.5mm ²				
Remote terminal torque		0.25Nm				

Ordering information

MCOV	300	600	1000	1200	1500
Ordering code SAFETEC C xxxx PV (3+0) UL	516.598	516.599	516.600	516.109	516.601
Ordering code SAFETEC CR xxxx PV (3+0) UL (with remote contacts)	516.594	516.595	516.596	516.110	516.597
Ordering code Module SAFETEC C(R) xxxx PV UL	516.602	516.603	516.604	516.210	516.605



Dimensions, Internal configuration, Weight and Packaging

SAFETEC C(R) xxxx PV (2+0) UL

Dimensions

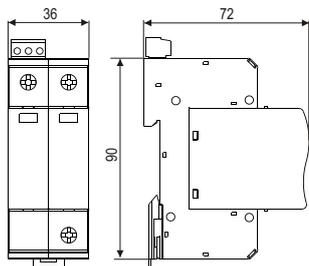

Internal configuration

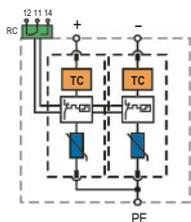

SAFETEC C xxxx PV (2+0) UL	300	600	1000
Dimensions DIN 43880	2TE		
Weight per unit	280g	290g	299g
SAFETEC CR xxxx PV (2+0) UL	300	600	1000
Dimensions DIN 43880	2TE		
Weight per unit	288g	298g	307g
Packaging dimensions (single unit)	109 x 76.5 x 41.5mm		
Min. packaging quantity	7 pcs.		

Module SAFETEC C(R) xxxx PV UL

Dimensions

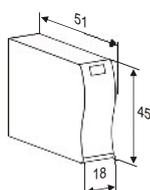

Internal configuration

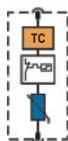

Module SAFETEC C(R) xxxx PV UL	300	600	1000
Weight per unit	68g	74g	78g
Packaging dimensions	219 x 62 x 47mm		
Min. packaging quantity	12 pcs.		

SAFETEC C(R) xxxx PV (3+0) UL

Dimensions

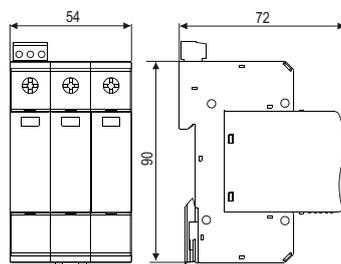

Internal configuration

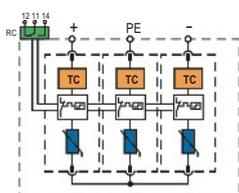

SAFETEC C xxxx PV (3+0) UL	300	600	1000	1200	1500
Dimensions DIN 43880	3TE				
Weight per unit	358g	370g	396g	390g	400g
SAFETEC CR xxxx PV (3+0) UL	300	600	1000	1200	1500
Dimensions DIN 43880	3TE				
Weight per unit	364g	376g	402g	392g	406g
Packaging dimensions (single unit)	109 x 76.5 x 60mm				
Min. packaging quantity	5 pcs.				

Module SAFETEC C(R) xxxx PV UL

Dimensions

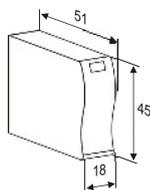

Internal configuration

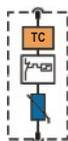

Module SAFETEC C(R) xxxx PV UL	300	600	1000	1200	1500
Weight per unit	62g	66g	74g	74g	76g
Packaging dimensions	219 x 62 x 47mm				
Min. packaging quantity	12 pcs.				



APPROVED

FILE
E 335214

SAFETEC C(R) xxxx PV UL Series

Connections

SAFETEC C(R) 300 - 1000 PV (2+0) UL

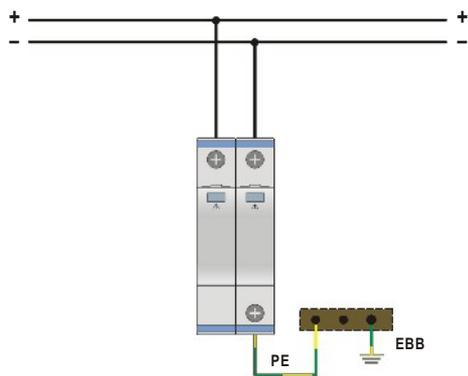

SAFETEC C(R) 300 - 1500 PV (3+0) UL

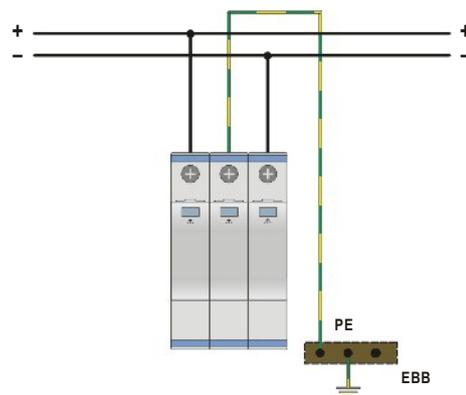

PV PROTEC C(R) 40



- Category IEC / EN / VDE: Class II / Type 2 / C
- Location of use: Photovoltaic systems - PV module side
- Protection modes: (+) → PE, (-) → PE, (+) → (-)
- Protective element: MOV
- Surge discharge rating: $I_{max} = 40kA$
- Housing: Modular design
- Complies with: EN 50539-11



Technical data

Type		100	PV PROTEC C(R) 40/xxxx		1000
			550	600	
Electrical characteristics					
Max. continuous operating voltage (DC)	U_{CPV}^* (+)→PE/(-)→PE	100V	550V	600V	1000V
	U_{CPV} per module	100V	550V	300V	500V
Nominal discharge current (8/20)	I_n	20kA per pole			
Max. discharge current (8/20)	I_{max}	40kA per pole			
Protection level	U_p	< 0.7kV	< 1.9kV	< 3.0kV	< 3.6kV
Residual voltage at 5kA (8/20)	U_{res}	< 0.4kV	< 1.6kV	< 2.2kV	< 3.0kV
Follow current	I_{fi}	NO			
Response time	t_A	< 25ns			
Thermal protection		YES			
Mechanical characteristics					
Temperature range		- 40°C ... + 80°C			
Terminal screw torque		max. 3.0Nm			
Terminal cross section		35mm ² (solid) / 25mm ² (stranded)			
Mounting		35mm DIN rail, EN 60715			
Degree of protection		IP 20			
Housing material		Thermoplastic; extinguishing degree UL 94 V-0			
Indication of disconnecter operation		red flag			
Remote contacts (RC)		YES			
Contact ratings		AC: 250V/0.5A; 125V/3A			
Terminal cross section		max. 1.5mm ²			
Remote terminal torque		0.25Nm			

* $U_{CPV} \geq 1.2 \cdot U_{OCSTC}$ → open circuit voltage under standard test condition

Ordering information

U_{CPV}	100	550	600	1000
Ordering code PV PROTEC C 40/xxxx	501.521	501.527	501.709	501.543
Ordering code PV PROTEC CR 40/xxxx (with remote contacts)	501.531	501.537	501.710	501.547
Ordering code Module PV PROTEC C(R) 40/xxxx	50.0496	50.0497	501.711	50.0498

Dimensions, Internal configuration, Weight, Packaging
Network connections

PV PROTEC C(R) 40/xxxx

Dimensions

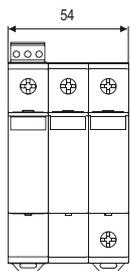
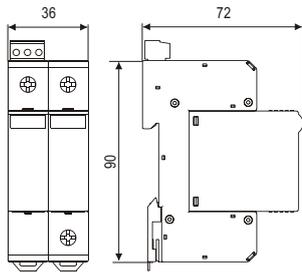

Internal configuration

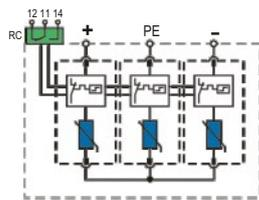
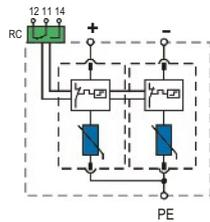

Dimensions, weight and packaging

PV PROTEC C 40/xxx	100	550
Dimensions DIN 43880	2TE	
Weight per unit	274g	302g
PV PROTEC CR 40/xxx	100	550
Dimensions DIN 43880	279g	307g
Weight per unit	2TE	
Packaging dimensions (single unit)	109 x 76.5 x 41.5mm	
Min. packaging quantity	7 pcs.	

Dimensions, weight and packaging

PV PROTEC C 40/xxxx	600	1000
Dimensions DIN 43880	3TE	
Weight per unit	329g	398g
PV PROTEC C 40/xxxx	600	1000
Dimensions DIN 43880	3TE	
Weight per unit	334g	403g
Packaging dimensions (single unit)	109 x 76.5 x 60mm	
Min. packaging quantity	5 pcs.	

Module PV PROTEC C(R) 40/xxxx

Dimensions

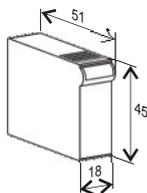

Internal configuration

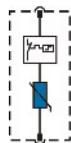

Dimensions, weight and packaging

Module PV PROTEC C(R) 40/xxxx	100	550	600	1000
Weight per unit	46g	58g	52g	58g
Packaging dimensions	219 x 62 x 47mm			
Min. packaging quantity	12 pcs.			

PV PROTEC C(R) 40/100, 40/550

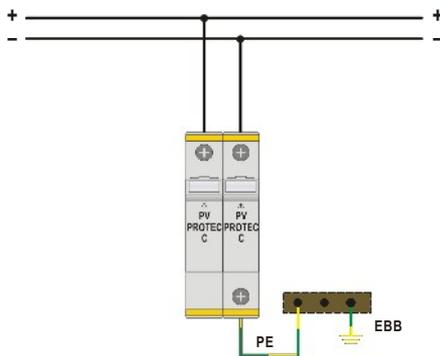

PV PROTEC C(R) 40/600, 40/1000

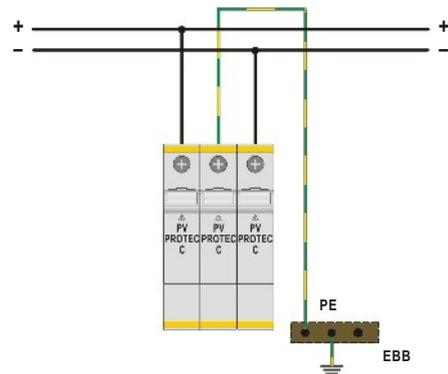

Class I, II SPD for Wind Systems



Category IEC / EN / VDE:

Location of use:

Protection modes:

Protective elements:

Surge discharge ratings:

Safety:

Internal protection:

Complies with:

Class I, II / Type 1, 2 / B+C

Distribution boards

L/N-PE, L-PEN

High energy MOV and GDT

Iimp up to 25kA

TOV immunity, TOV withstand for unlimited time

Separate thermal disconnecter for each MOV

IEC/EN 61643-11, UL 1449 3rd Ed.

The new SAFETEC B(R) WT TCG* of surge protective devices (SPDs):

- **Are highly reliable - controlled disconnection, arc-quenching**
- **Are safer - controlled behaviour even when surge ratings are exceeded**
- **Have longer life - protection against ageing**
- **Have up to 20 years warranty**

SAFETEC B(R) WT TCG Series:

SAFETEC B(R) 12.5/xxx WT TCG

SAFETEC B(R) 25/xxx WT TCG

SAFETEC C(R) xxx (3+0) WT

SAFETEC C(R) xxx (3+0) WT UL

SAFETEC B(R) WT TCG series provides common and differential protection mode.

Patented TCG technology provides high level of reliability and safety in Wind systems.

A unique indicator monitors all disconnectors and brings up a common status flag if any of current branches fails.

TCG technology means no leakage current.

Combination of GDT + MOV prevents intensive ageing of components thereby prolonging the SPDs life-span.

Selection of SPDs should adhere to national and international standards.

*TCG - Thermal control function without leakage current
TC - Thermal control function



SAFETEC B(R) 12.5 WT TCG

- **Category IEC / EN / VDE:** Class I, II / Type 1, 2 / B, C
- **Location of use:** Main distribution boards
- **Network systems:** TN-S, TN-C, IT, TT
- **Protection modes:** L/N - PE, L- PEN
- **Protective elements:** High energy MOV and GDT
- **Surge discharge rating:** $I_{imp} = 12.5kA$
- **Safety:** TOV immunity
- **Leakage current:** NO leakage current (TCG)
- **Housing:** Compact design
- **Complies with:** IEC/EN 61643-11, UL 1449 3rd Ed.

Technical data

Type	SAFETEC B(R) 12.5/xxx WT TCG		
		440	750
Electrical characteristics			
Max. continuous operating voltage (AC/DC)	U_c	440/580V	750/1000V
Nominal discharge current (8/20)	I_n		12.5kA
Max. discharge current (8/20)	I_{max}		40kA
Impulse current (10/350)	I_{imp}		12.5kA
Specific energy			39kJ/Ω
Charge			6.25As
Protection level	U_p	< 1.6kV	< 2.4kV
Residual voltage at 5kA (8/20)	U_{res}	< 1.4kV	< 2.1kV
Follow current	I_{fi}		NO
Response time	t_A		< 25ns
Thermal protection			YES
Back-up fuse (if mains > 160A)			160A gL
TOV immunity (withstand for unlimited time up to)	U_T	580V	1000V
Mechanical characteristics			
Terminal screw torque			max. 3.0Nm
Temperature range			- 40°C + 80°C
Terminal cross section			35mm ² (solid) / 25mm ² (stranded)
Mounting			35mm DIN rail, EN 60715
Degree of protection			IP 20
Housing material			thermoplastic; extinguishing degree UL 94 V-0
Indication of disconnector operation			red flag
Remote contacts (RC)			YES
Contact ratings			AC: 250V/0.5A; 125V/3A
Terminal cross section			max. 1.5mm ²
Remote terminal torque			0.25Nm

Ordering information

U_c	440	750
Ordering code SAFETEC B 12.5/xxx WT TCG	54.0320	54.0078
Ordering code SAFETEC BR 12.5/xxx WT TCG (with remote contacts)	54.0321	54.0079

TC solution available on request

SAFETEC B(R) 25 WT TCG

- **Category IEC / EN / VDE:** Class I, II / Type 1, 2 / B, C
- **Location of use:** Main distribution boards
- **Network systems:** TN-S, TN-C, IT, TT (only L-N)
- **Protection modes:** L/N - PE, L- PEN
- **Protective elements:** High energy MOV and GDT
- **Surge discharge rating:** $I_{imp} = 25kA$
- **Safety:** TOV immunity
- **Leakage current:** NO leakage current (TCG)
- **Housing:** Compact design
- **Complies with:** IEC/EN 61643-11, UL 1449 3rd Ed.

Technical data

Type	SAFETEC B(R) 25/xxx WT TCG		
	440		750
Electrical characteristics			
Max. continuous operating voltage (AC/DC)	U_c	440/580V	750/1000V
Nominal discharge current (8/20)	I_n		25kA
Max. discharge current (8/20)	I_{max}		80kA
Impulse current (10/350)	I_{imp}		25kA
Specific energy			156kJ/Ω
Charge			12.5As
Protection level	U_p	< 1.9kV	< 2.5kV
Residual voltage at 5kA (8/20)	U_{res}	< 1.4kV	< 2.1kV
Follow current	I_{fi}		NO
Response time	t_A		< 25ns
Thermal protection			YES
Back-up fuse (if mains > 250A)			250A gL
TOV immunity (withstand for unlimited time up to)	U_T	580V	1000V
Mechanical characteristics			
Terminal screw torque			max. 3.0Nm
Temperature range			- 40°C + 80°C
Terminal cross section			35mm ² (solid) / 25mm ² (stranded)
Mounting			35mm DIN rail, EN 60715
Degree of protection			IP 20
Housing material			thermoplastic; extinguishing degree UL 94 V-0
Indication of disconnector operation			red flag
Remote contacts (RC)			YES
Contact ratings			AC: 250V/0.5A; 125V/3A
Terminal cross section			max. 1.5mm ²
Remote terminal torque			0.25Nm

Ordering information

U_c	440	750
Ordering code SAFETEC B 25/xxx WT TCG	54.0322	54.0080
Ordering code SAFETEC BR 25/xxx WT TCG (with remote contacts)	54.0323	54.0081

TC solution available on request



Dimensions, Internal configuration, Weight, Packaging, Network connections

SAFETEC B(R) 12.5/xxx WT TCG

Dimensions

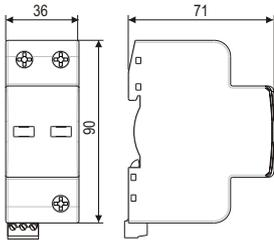

Internal configuration

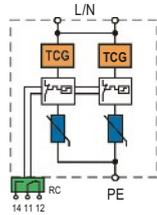

SAFETEC B 12.5/xxx WT TCG	440	750
Dimensions DIN 43880	2TE	
Weight per unit	371g	400g
SAFETEC BR 12.5/xxx WT TCG	440	750
Dimensions DIN 43880	2TE	
Weight per unit	376g	405g
Packaging dimensions (single unit)	109 x 76.5 x 41.5mm	
Min. packaging quantity	7 pcs.	

SAFETEC B(R) 25/xxx WT TCG

Dimensions

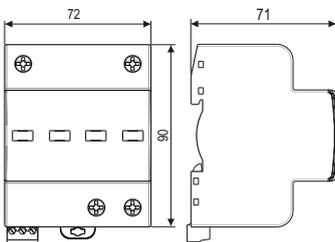

Internal configuration

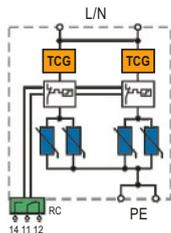

SAFETEC B 25/xxx WT TCG	440	750
Dimensions DIN 43880	4TE	
Weight per unit	692g	800g
SAFETEC BR 25/xxx WT TCG	440	750
Dimensions DIN 43880	4TE	
Weight per unit	697g	805g
Packaging dimensions (single unit)	109 x 76.5 x 78mm	
Min. packaging quantity	3 pcs.	

T connection

SAFETEC B(R) 12.5 WT TCG

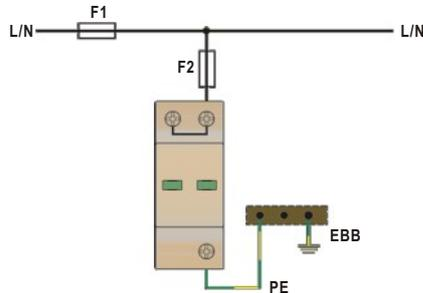

SAFETEC B(R) 25 WT TCG

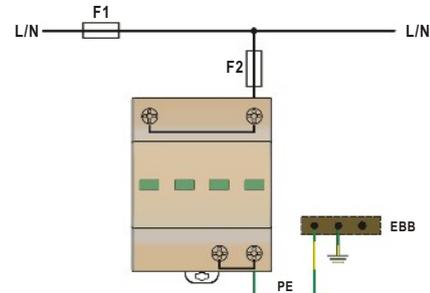

V connection

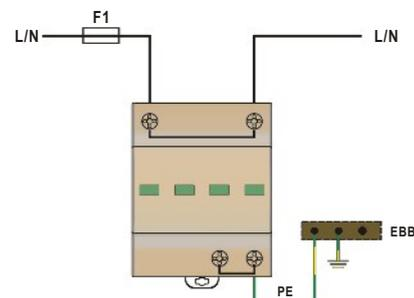
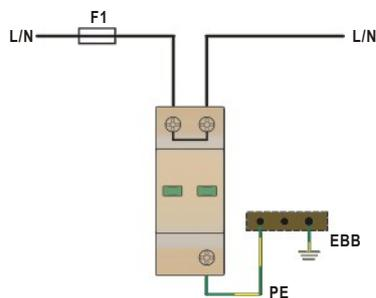

Back-up fuse

SAFETEC B(R) 12.5 WT TCG

- F1 > 160 A gL → F2 = 160 A gL
- F1 ≤ 160 A gL → F2

SAFETEC B(R) 25 WT TCG

- F1 > 250 A gL → F2 = 250 A gL
- F1 ≤ 250 A gL → F2

SAFETEC C(R) (3+0) WT

- **Category IEC / EN / VDE:** Class II / Type 2 / C
- **Location of use:** Sub-distribution boards
- **Network system:** TN-C
- **Protection modes:** L - PEN
- **Protective elements:** MOV and GDT
- **Surge discharge rating:** I_{max} up to 40kA
- **Safety:** TOV withstand for unlimited time
- **Housing:** Modular design
- **Complies with:** IEC/EN 61643-11

Technical data

Type	SAFETEC C(R) xxx (3+0) WT			
	440	750	880	
Electrical characteristics				
Max. continuous operating voltage (AC/DC)	U_C	440/580V	750/1000V	880/1170V
Nominal discharge current (8/20)	I_n (L-PEN)	20kA per pole	12.5kA per pole	12.5kA per pole
Max. discharge current (8/20)	I_{max} (L-PEN)	40kA per pole	25kA per pole	25kA per pole
Protection level	U_p	< 2.3kV	< 2.8kV	< 3.0kV
Residual voltage at 5kA (8/20)	U_{res}	< 1.6kV	< 2.2kV	< 2.4kV
Follow current	I_{fi}		NO	
Response time	t_A		< 25ns	
Thermal protection			YES	
Short-circuit withstand current	I_{SCCR}		25kA/50Hz	
Back-up fuse (if mains > 125A)			125A gL	
TOV withstand for unlimited time up to	U_T	690V	1000V	1100V
Mechanical characteristics				
Terminal screw torque			max. 3.0Nm	
Temperature range			- 40°C + 80°C	
Terminal cross section			35mm ² (solid) / 25mm ² (stranded)	
Mounting			35mm DIN rail, EN 60715	
Degree of protection			IP 20	
Housing material			thermoplastic; extinguishing degree UL 94 V-0	
Indication of disconnecter operation			red flag	
Remote contacts (RC)			YES	
Contact ratings			AC: 250V/0.5A; 125V/3A	
Terminal cross section			max. 1.5mm ²	
Remote terminal torque			0.25Nm	

Ordering information

U_C	440	750	880
Ordering code SAFETEC C xxx (3+0) WT	516.652	516.055	516.369
Ordering code SAFETEC CR xxx (3+0) WT (with remote contacts)	516.653	516.056	516.370
Ordering code Module SAFETEC C(R) xxx WT	516.654	516.057	516.371

TC solution available on customers request

Dimensions, Internal configuration, Weight, Packaging , Network connections

SAFETEC C(R) (3+0) xxx WT

Dimensions

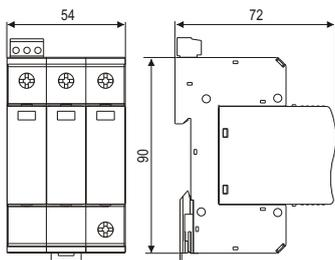

Internal configuration

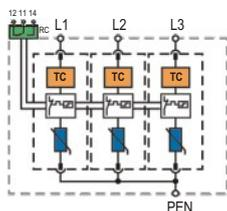

SAFETEC C xxx (3+0) WT	440	750	880
Dimensions DIN 43880	3TE		
Weight per unit	397g	364g	364g
SAFETEC CR xxx (3+0) WT	440	750	880
Dimensions DIN 43880	3TE		
Weight per unit	402g	369g	369g
Packaging dimensions (single unit)	109 x 76.5 x 60mm		
Min. packaging quantity	5 pcs.		

Module SAFETEC C(R) xxx WT

Dimensions

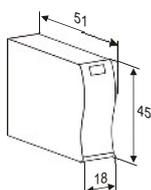

Internal configuration

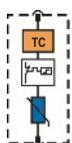

Module SAFETEC C(R) xxx WT	440	750	880
Weight per unit	74g	78g	78g
Packaging dimensions	219 x 62 x 47mm		
Min. packaging quantity	12 pcs.		

SAFETEC C(R) (3+0) WT

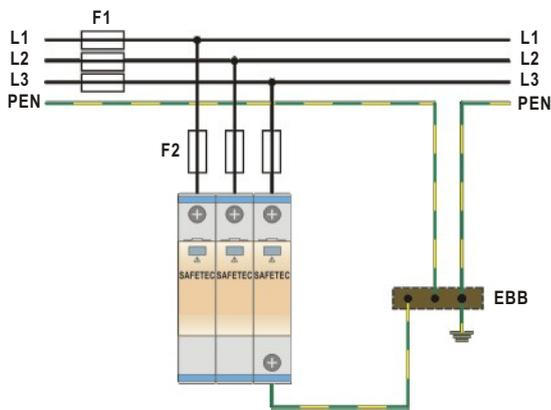

Back-up fuse
SAFETEC C(R) (3+0) WT

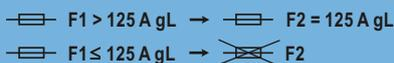



SAFETEC C(R) (3+0) WT UL



- **Classification UL 1449 3rd Ed.:** Type 2 Surge Protective Device
- **Location of use:** Sub-distribution boards
- **Protection modes:** L - PEN (G)
- **Protective elements:** MOV and GDT
- **Surge discharge rating:** I_{max} up to 50kA
- **Safety:** TOV withstand for unlimited time
- **Housing:** Modular design
- **Complies with:** UL 1449 3rd Ed.



Technical data

Type	SAFETEC C(R) xxx (3+0) WT UL			
	440	690	750	
Electrical characteristics				
Max. continuous operating voltage (AC)	MCOV	440V	690V	750V
Nominal discharge current (8/20)	I_n	20kA per pole	10kA per pole	10kA per pole
Max. discharge current (8/20)	I_{max}	50kA per pole	20kA per pole	20kA per pole
Voltage protection rating per UL 1449 3rd ed.	VPR	< 2.0kV	< 2.5kV	< 2.5kV
Short-circuit withstand current	SCCR		200kA	
Follow current	I_{fi}		NO	
Response time	t_A		< 25ns	
Thermal protection			YES	
Mechanical characteristics				
Terminal screw torque			max. 3.0Nm	
Temperature range			-40°C + 80°C	
Terminal cross section			35mm ² (solid) / 25mm ² (stranded)	
Mounting			35mm DIN rail, EN 60715	
Degree of protection			IP 20	
Housing material			thermoplastic; extinguishing degree UL 94 V-0	
Indication of disconnecter operation			red flag	
Remote contacts (RC)			YES	
Contact ratings			AC: 250V/0.5A; 125V/3A	
Terminal cross section			max. 1.5mm ²	
Remote terminal torque			0.25Nm	

Ordering information

MCOV	440	690	750
Ordering code SAFETEC C xxx (3+0) WT UL	516.225	516.227	516.229
Ordering code SAFETEC CR xxx (3+0) WT UL (with remote contacts)	516.226	516.228	516.230
Ordering code Module SAFETEC C(R) xxx WT UL	516.262	516.263	516.264



APPROVED

FILE
E 335214

Dimensions, Internal configuration, Weight, Packaging, Network connections

SAFETEC C(R) (3+0) xxx WT UL

Dimensions

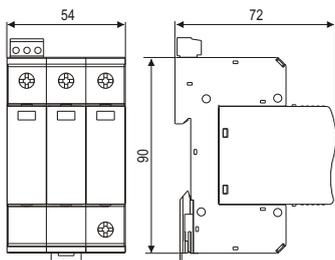

Internal configuration

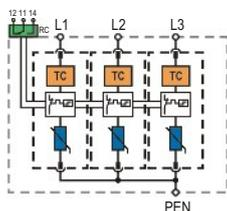

SAFETEC C xxx (3+0) WT UL	440	690	750
Dimensions DIN 43880	3TE		
Weight per unit	397g	364g	364g
SAFETEC CR xxx (3+0) WT UL	440	690	750
Dimensions DIN 43880	3TE		
Weight per unit	402g	369g	369g
Packaging dimensions (single unit)	109 x 76.5 x 60mm		
Min. packaging quantity	5 pcs.		

Module SAFETEC C(R) xxx WT UL

Dimensions

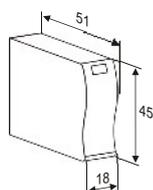

Internal configuration

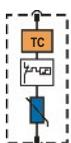

Module SAFETEC C(R) xxx WT UL	440	690	750
Weight per unit	74g	78g	78g
Packaging dimensions	219 x 62 x 47mm		
Min. packaging quantity	12 pcs.		

SAFETEC C(R) (3+0) WT UL

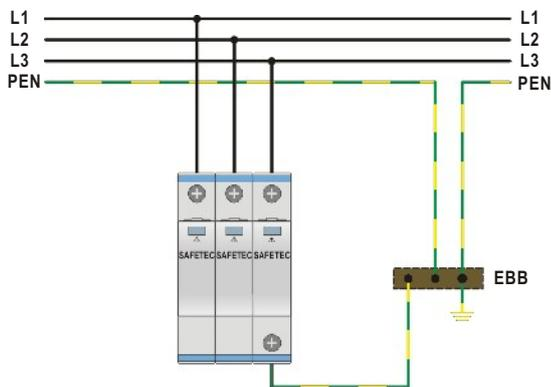

PV Combiner Boxes for Photovoltaic Systems



Category IEC / EN / VDE:

Location of use:

Protection modes:

Protective elements:

Safety:

Complies with:

Class I, II / Type 1, 2 / B, C

Photovoltaic power plants

(+) → PE, (-) → PE, (+) → (-)

SPD, fuse, switch, steering diode

Ground fault immunity, ground fault withstand

EN 50539-11, prEN 50539-12

PVCB I Series
PVCB II Series

Iskra Zaščite manufactures a range of PV Combiner Boxes for use in Photovoltaic systems. Various models are available including surge protection, DC fuses, DC isolation switches or steering diodes and are compliant with relevant standards such as prEN 50539-12.

Features:

- Waterproof housing IP 65 RAL 7035 with transparent front cover
- Safe and easy installation
- Up to 1500VDC
- Up to 6 strings
- Leakage free version - optional
- String current up to 8A
- Customised designs



PVCB I Series



- **Category IEC/EN/VDE:** Class I, II / Type 1, 2 / B, C
- **Location of use:** Photovoltaic power plants
- **Surge Protections modes:** (+) → PE, (-) → PE, (+) → (-)
- **Safety:** Overload immunity
- **Options:** DC fuses, isolation switch, steering diodes
- **Housing:** IP 65 enclosures
- **Complies with:** EN 50539-11, prEN 50539-12



Technical data

Electrical characteristic						
Max. strings input	2	4	6	2	4	6
Max. current per string (DC fuse per + string)	< 8A					
U _C (DC)	600V	600V	600V	1000V	1000V	1000V
I _{max} (8/20)	40kA					
I _{imp} (10/350)	12.5kA					
Mechanical characteristics						
Degree of protection	IP65					
Terminal cross section	string	6 mm ²			6 mm ²	
	inverter	6 mm ²	10 mm ²	16 mm ²	6 mm ²	10 mm ² 16 mm ²
Housing material	Technical polymer - transparent front RAL 7035					

Ordering information

Type	PVCB I	PVCB I	PVCB I	PVCB I	PVCB I	PVCB I
- Fuse only on + side	2-0.6	4-0.6	6-0.6	2-1	4-1	6-1
Ordering code	130 130	130 131	130 132	130 133	130 134	130 135
Type	PVCB I	PVCB I	PVCB I	PVCB I	PVCB I	PVCB I
- Fuse on + and - side	2-0.6-F	4-0.6-F	6-0.6-F	2-1-F	4-1-F	6-1-F
Ordering code	130 136	130 137	130 138	130 139	130 140	130 141
Type	PVCB I	PVCB I	PVCB I	PVCB I	PVCB I	PVCB I
- Main isolation switch	2-0.6-MS-F	4-0.6-MS-F	6-0.6-MS-F	2-1-MS-F	4-1-MS-F	6-1-MS-F
- DC fuse on + and - side						
Max. rated current (DC isolation switch)	32A	63A	63A	32A	63A	63A
Ordering code	130 142	130 143	130 144	130 145	130 146	130 147
Type	PVCB I	PVCB I	PVCB I	PVCB I	PVCB I	PVCB I
- Main isolation switch	2-0.6-MS-D	4-0.6-MS-D	6-0.6-MS-D	2-1-MS-D	4-1-MS-D	6-1-MS-D
- Steering diode on - side						
Ordering code	130 148	130 149	130 150	130 151	130 152	130 153

Various PV combiner boxes available on request

PVCB II Series



- **Category IEC/EN/VDE:** Class II / Type 2 / C
- **Location of use:** Photovoltaic power plants
- **Surge Protections modes:** (+) → PE, (-) → PE, (+) → (-)
- **Safety:** Overload immunity
- **Options:** DC fuses, isolation switch, steering diodes
- **Housing:** IP 65 enclosures
- **Complies with:** EN 50539-11, prEN 50539-12



Technical data

Electrical characteristic							
Max. strings input		2	4	6	2	4	6
Max. current per string (DC fuse per + string)					< 8A		
U _C (DC)		600V	600V	600V	1000V	1000V	1000V
I _{max} (8/20) (+) → PE/(-) → PE					40kA		
I _{in} (8/20) (+) → PE/(-) → PE					20kA		
Mechanical characteristics							
Degree of protection					IP65		
Terminal cross section	string		6 mm ²			6 mm ²	
	inverter	6 mm ²	10 mm ²	16 mm ²	6 mm ²	10 mm ²	16 mm ²
Housing material		Technical polymer - transparent front RAL 7035					

Ordering information

Type	PVCB II	PVCB II	PVCB II	PVCB II	PVCB II	PVCB II
- Fuse only on + side	2-0.6	4-0.6	6-0.6	2-1	4-1	6-1
Ordering code	130 154	130 155	130 156	130 157	130 158	130 159

Type	PVCB II	PVCB II	PVCB II	PVCB II	PVCB II	PVCB II
- Fuse on + and - side	2-0.6-F	4-0.6-F	6-0.6-F	2-1-F	4-1-F	6-1-F
Ordering code	130 160	130 161	130 162	130 1639	130 164	130 1651

Type	PVCB II	PVCB II	PVCB II	PVCB II	PVCB II	PVCB II
- Main isolation switch	2-0.6-MS-F	4-0.6-MS-F	6-0.6-MS-F	2-1-MS-F	4-1-MS-F	6-1-MS-F
- DC fuse on + and - side						
Max. rated current (DC isolation switch)	32A	63A	63A	32A	63A	63A
Ordering code	130 166	130 167	130 168	130 169	130 170	130 171

Type	PVCB II	PVCB II	PVCB II	PVCB II	PVCB II	PVCB II
- Main isolation switch	2-0.6-MS-D	4-0.6-MS-D	6-0.6-MS-D	2-1-MS-D	4-1-MS-D	6-1-MS-D
- Steering diode on - side						
Ordering code	130 172	130 173	130 174	130 175	130 176	130 177

Various PV combiner boxes available on request

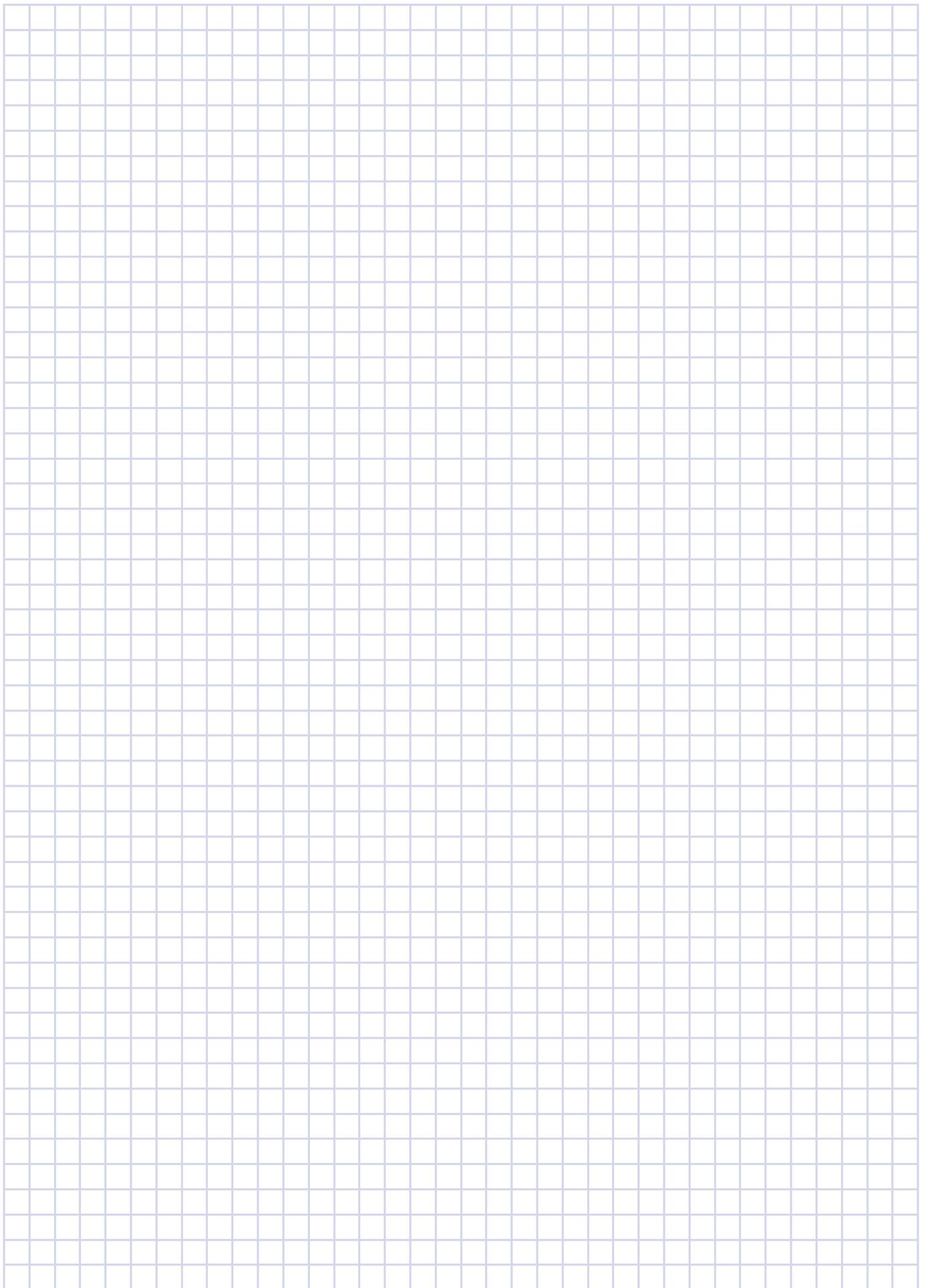

AC Boxes



Location of use:	Indoor and outdoor
Protection modes:	As close as possible to equipment to be protected
Protective elements:	L-N, N-PE
Housing:	SPD, surge filter, fuse, MCB
	Waterproof enclosure (IP 65)

PB Series

The PB series is intended to provide protection for electric appliances and equipment with sensitive electronic components and are installed directly before the protected equipment. Moisture and water resistant enclosures (IP 65) are used.



PROFILT PSF Series

The Profilt PSF series combines Class I and II SPDs, a special low-pass filter and overcurrent protection. The low-pass filter plays an important role in reducing the fast rate of rise (du/dt) associated with lightning discharges and surge transients. This helps reduce the stress on sensitive electronic components.

PB Series



- **Category IEC/EN/VDE:** Class II, III / Type 2, 3 / C, D
- **Location of use:** As close as possible to equipment to be protected
- **Max. rated current:** 16A
- **Protection modes:** L/N-PE
- **Protection elements:** MOV, GDT, CB
- **Housing :** Waterproof enclosure (IP 65)
- **Complies with:** IEC/EN 61643-11



Technical data

Electrical characteristic		Class II	Class II	Class III
Category IEC		TN	TT	TN
Network system				
Max. continuous operating voltage (AC/DC) at 50/60Hz	U_c		320V/420V	
Nominal system voltage	U_o		220V - 240V _{AC} 50/60Hz	
Nominal discharge current (8/20)	I_n	20kA per pole	20kA/20kA	/
Max. discharge current (8/20)	I_{max}	40kA per pole	40kA/20kA	/
Open circuit voltage of the combination wave generator	U_{oc}	/	/	10kV
Protection level	U_p	1.5kV	1.5kV	1.2kV
Mechanical characteristics				
Operating temperature			- 40°C...+ 80°C	
Degree of protection			IP 65	
Housing material			technical polymer	

Type	PBS-C80 (2+0)-F16	PBS-C80 (1+1)-F16	PBS-D10 (2+0)-F16
1 phase			
Socket 230V		1	
Circuit breaker (CB)		16A	
Housing dimensions (W x H x D)		9.8 x 24.8 x 11.4 cm	
Ordering code	130 021	130 022	130 023

Type	PBL-C160 (4+0)-F16	PBL-C160 (3+1)-F16	PBL-D40 (4+0)-F16
3 phase			
Socket 230V , socket 5 poles, main switch		1	
Circuit breaker (CB)		4 x 16A	
Housing dimensions (W x H x D)		34 x 33.5 x 17.5 cm	
Ordering code	130 024	130 025	130 026

Internal configuration

TN Network

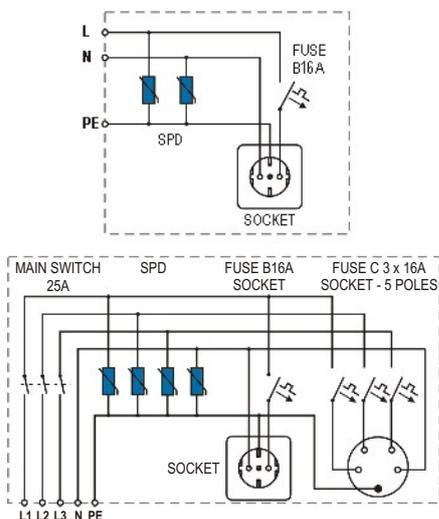

TT Network

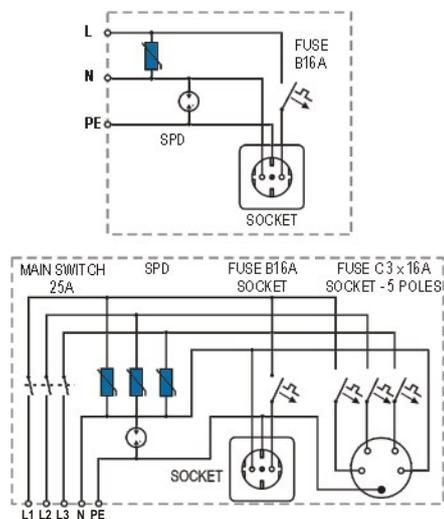

PROFILT PSF Series



- **Category IEC/EN/VDE:** Class I, II / Type 1, 2 / B, C
- **Location of use:** As close as possible to equipment to be protected
- **Max. rated current:** 40A, 63A
- **Protection modes:** L/N-PE
- **Protection elements:** MOV, GDT, surge filter
- **Housing :** Waterproof metal enclosure
- **Complies with:** IEC/EN 61643-11



Technical data

Type	40A	PROFILT PSF yy		63A
Electrical characteristic				
Network system	TT, TN-S		TT, TN-S	
Max. continuous operating voltage(AC/DC) at 50/60Hz	U_c		320V/420V	
Nominal system voltage	U_o		220V - 240V _{AC} 50/60Hz	
Max. Load current	I_L		40A	
Max. discharge current (8/20)	I_{max} (L-N)		100kA	150kA
Impulse current (10/350)	I_{imp} (L-N)		25kA	50kA
Voltage protection level 20kA (8/20)	U_p		< 680kV	< 580kV
Voltage protection level 25kA (8/20)	U_p		< 670kV	< 570kV
Max. voltage drop	ΔU		< 1%	
Mechanical characteristics				
Operating temperature	- 20°C...+ 40°C		- 20°C...+ 40°C	
Terminal cross section	16mm ²		35mm ²	
Housing material	metal			

Type	PROFILT PSF (1 phase)		PROFILT PSF (3 phase)	
	1/40/320/TT 25kA	1/40/320/TT 50kA	1/63/320/TT 25kA	1/63/320/TT 50kA
Distribution systems	L1, N, PE			
Mounting	Wall mount			
Dimensions (w x h x d)	30 x 40 x 16cm			
Weight	9kg	9.5kg	9kg	9.5kg
Ordering code	130 086	130 046	130 079	130 070

Type	PROFILT PSF (1 phase)		PROFILT PSF (3 phase)	
	3/40/320/TT 25kA	3/40/320/TT 50kA	3/63/320/TT 25kA	3/63/320/TT 50kA
Distribution systems	L1, L2, L3, N, PE			
Mounting	Wall mount			
Dimensions (w x h x d)	40 x 50 x 21cm			
Weight	17kg	18kg	17kg	18kg
Ordering code	130 083	130 048	130 044	130 056

Internal configuration

TT, TN-S Network

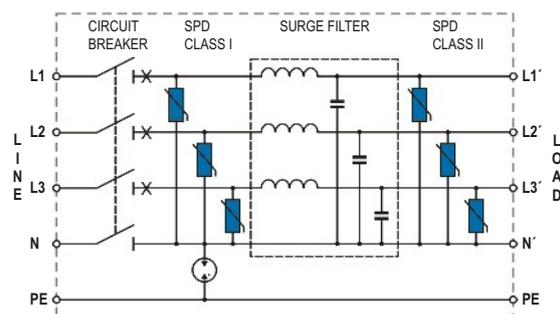
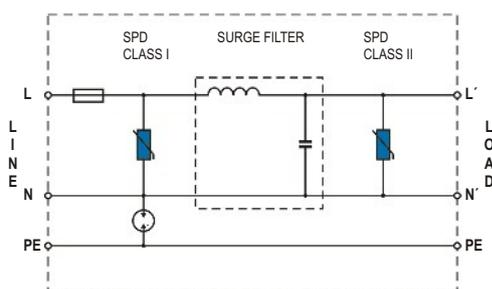

Class II SPD for Overhead Power Lines



Category IEC / EN / VDE:	Class II / Type 2 / A
Location of use:	Overhead power lines
Protection modes:	L/N-PE
Protective element:	MOV
Surge discharge ratings:	I_{max} up to 40kA
Internal protection and safety:	Thermal disconnecter
Complies with:	IEC/EN 61643-11

PROTEC AQ 25/xxx
PROTEC AQ 40/xxx
PROTEC AQS 40/xxx

The PROTEC AQ series of overvoltage surge protective devices has been developed to protect against indirect lightning discharges on overhead power lines. It consists of a high performance varistor with disconnection device which protects against short circuit conditions.

PROTEC AQS - provides the same compactness as the PROTEC AQ series but with a silicon jacket for greater hermetic sealing properties.

PROTEC AQ 25



- Category IEC / EN / VDE: Class II / Type 2 / A
- Location of use: Overhead power lines
- Network systems: TN-C, TN-S, IT
- Protection modes: L/N - PE
- Protective element: MOV
- Surge discharge rating: $I_{max} = 25kA$
- Housing: Compact design
- Complies with: IEC/EN 61643-11



Technical data

Type		150	275	PROTEC AQ 25/xxx		
				320	385	440
Electrical characteristics						
Max. continuous operating voltage (AC/DC)	U_c	150/200V	275/350V	320/420V	385/500V	440/580V
Nominal discharge current (8/20)	I_n	10kA				
Max. discharge current (8/20)	I_{max}	25kA				
Protection level	U_p	< 0.9kV	< 1.3kV	< 1.4kV	< 1.7kV	< 1.9kV
Residual voltage at 5kA (8/20)	U_{res}	< 0.7kV	< 1.0kV	< 1.0kV	< 1.2kV	< 1.4kV
Follow current	I_{fi}	NO				
Response time	t_A	< 25ns				
Thermal protection		YES				
Back-up fuse		NO				
Short-circuit withstand current	I_{SCCR}	25kA/50Hz				
Mechanical characteristics						
Temperature range		- 40°C + 80°C				
Terminal screw torque		max. 3.5Nm				
Terminal cross section	L/N	M8				
	PE	6mm ² (stranded)				
Mounting		outdoors				
Degree of protection		IP 20				
Housing material		Thermoplastic; extinguishing degree UL 94 V-0				
Indication of disconnector operation		disconnected cable				

Ordering information

U_c	150	275	320	385	440
Ordering code PROTEC AQ 25/xxx	509.017	509.019	509.021	509.045	509.023

Dimensions

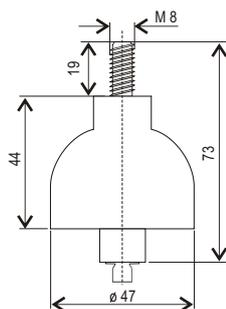

Internal configuration

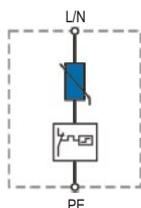

Dimensions, weight and packaging

PROTEC AQ 25/xxx	150	275	320	385	440
Weight per unit	104g	106g	108g	110g	112g
Packaging dimensions	295 x 245 x 210mm				
Packaging quantity	60 pcs.				

PROTEC AQ 40



- Category IEC / EN / VDE: Class II / Type 2 / A
- Location of use: Overhead power lines
- Network systems: TN-C, TN-S, IT
- Protection modes: L/N - PE
- Protective element: MOV
- Surge discharge rating: $I_{max} = 40kA$
- Housing: Compact design
- Complies with: IEC/EN 61643-11



Technical data

Type		150	275	PROTEC AQ 40/xxx		
				320	385	440
Electrical characteristics						
Max. continuous operating voltage (AC/DC)	U_c	150/200V	275/350V	320/420V	385/500V	440/580V
Nominal discharge current (8/20)	I_n	20kA				
Max. discharge current (8/20)	I_{max}	40kA				
Protection level	U_p	< 1.2kV	< 1.7kV	< 1.8kV	< 2.1kV	< 2.3kV
Residual voltage at 5kA (8/20)	U_{res}	< 0.7kV	< 1.0kV	< 1.0kV	< 1.3kV	< 1.5kV
Follow current	I_{fi}	NO				
Response time	t_A	< 25ns				
Thermal protection		YES				
Back-up fuse		NO				
Short-circuit withstand current	I_{SCCR}	25kA/50Hz				
Mechanical characteristics						
Temperature range		- 40°C + 80°C				
Terminal screw torque		max. 3.5Nm				
Terminal cross section	L/N	M8				
	PE	6mm ² (stranded)				
Mounting		outdoors				
Degree of protection		IP 20				
Housing material		Thermoplastic; extinguishing degree UL 94 V-0				
Indication of disconnector operation		disconnected cable				

Ordering information

U_c	150	275	320	385	440
Ordering code PROTEC AQ 40/xxx	509.029	509.031	509.033	509.047	509.035

Dimensions

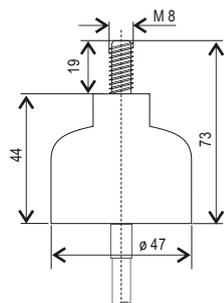

Internal configuration

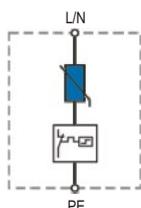

Dimensions, weight and packaging

PROTEC AQ 40/xxx	150	275	320	385	440
Weight per unit	144g	146g	149g	154g	157g
Packaging dimensions	290 x 250 x 210mm				
Packaging quantity	60 pcs				

PROTEC AQS 40



- Category IEC / EN / VDE: Class II / Type 2 / A
- Location of use: Overhead power lines
- Network systems: TN-C, TN-S, IT
- Protection modes: L/N - PE
- Protective element: MOV
- Surge discharge rating: $I_{max} = 40kA$
- Housing: Compact design
- Complies with: IEC/EN 61643-11



Technical data

Type		150	PROTEC AQS 40/xxx 275	320	440
Electrical characteristics					
Max. continuous operating voltage (AC/DC)	U_c	150/200V	275/350V	320/420V	440/580V
Nominal discharge current (8/20)	I_n	20kA			
Max. discharge current (8/20)	I_{max}	40kA			
Protection level	U_p	< 0.9kV	< 1.4kV	< 1.4kV	< 2.0kV
Residual voltage at 5kA (8/20)	U_{res}	< 0.7kV	< 1.0kV	< 1.0kV	< 1.5kV
Follow current	I_{fi}	NO			
Response time	t_A	< 25ns			
Thermal protection		YES			
Back-up fuse		NO			
Short-circuit withstand current	I_{SCCR}	25kA/50Hz			
Mechanical characteristics					
Temperature range		- 40°C + 80°C			
Terminal screw torque		max. 3.5Nm			
Terminal cross section	L/N	M8			
	PE	6mm ² (stranded)			
Mounting		outdoors			
Degree of protection		IP 67			
Housing material		Silicon			
Indication of disconnector operation		disconnected cable			

Ordering information

U_c	150	275	320	440
Ordering code PROTEC AQS 40/xxx	509 049	509 051	509 053	509 055

Dimensions

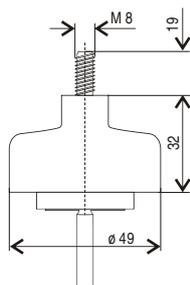

Internal configuration

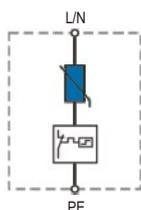

Dimensions, weight and packaging

PROTEC AQS 40/xxx	150	275	320	440
Weight per unit	122g	126g	130g	134g
Packaging dimensions	382 x 349 x 250mm			
Packaging quantity	100 pcs			

Isolating Spark Gaps (ISG) for Equipotential Bonding



Location of use:	Exposed environments or direct burial
Protective element:	GDT
High surge discharge rating:	$I_{max} = 100kA$
Housing:	Corrosion resistant enclosure with hermetic environmental seal and flying leads for ease of connection
Complies with:	IEC 61643-11, EN 50164-3:2004

EPZ 100/xxx
EPZ 100/xxx Ex

The EPZ series of isolating spark gaps have been developed to prevent unsafe potential gradients from establishing between adjacent metallic structures or surfaces during lightning discharges. This is achieved by an internal voltage switching component which operates to establish equi-potential equalisation when its predetermined spark-over voltage is reached, thereby preventing damage to equipment or eliminating unsafe conditions to personnel.

The EPZ has been developed for use in applications such as: lightning protection grounding, where for instance circumstances may dictate that a “clean” signal ground can not be directly connected to a “dirty” power system ground. It has also found wide application in the petrochemical industry in the protection of oil and gas pipeline insulating flanges from flash-overs during direct or nearby lightning discharges or when ground faults of nearby power transmission lines can cause large potential gradients across these flanges. The EPZ is available in a hermetically sealed version for direct burial applications. It is also available with Baseefa **Ex approval certificate** for use in hazardous locations.

Surge protection devices for Data/signal lines with Ex certificate are also available. Data sheets are available in catalogue “Surge Protection Devices for Signalling Networks”.

These devices have been developed to meet the requirements EN 50164-3 Lightning Protection Components (LPC) - Requirements for Isolating Spark Gaps, and IEC 62561-3 Ed. 1.0 - Requirements for Lightning Protection Components (LPC) - Part 3: Requirements for isolating spark gaps.

EPZ 100/xxx



- **Location of use:** Exposed environments or direct burial
- **Protective element:** GDT
- **High surge discharge rating:** $I_{max} = 100kA$
- **Housing:** Corrosion resistant enclosure with hermetic environmental seal and flying leads for ease of connection
- **Complies with:** IEC 61643-11, EN 50164-3:2004



Technical data

Type		350	EPZ 100/xxx	500
Electrical Characteristics				
DC sparkover voltage (100V/s)	U_{dc}	> 280V		> 400V
Impulse sparkover voltage (1.2/50 μ s, 6kV)	U_p	< 1000V		< 1500V
Max. discharge current (8/20 μ s)	I_{max}		100kA	
Impulse discharge current (10/350 μ s)	I_{imp}		25kA	
Capacitance at 1MHz	C		< 10pf	
Insulation resistance at 100V _{DC}	R		> 1G Ω	
Dimensions				
Nom. outer diameter			28mm	
Nom. length			140mm	
Length with cables			1m approx.	
Cable				
Cross sectional area			16mm ²	
Length			450mm approx.	
Number of conductors			$\geq 462/0.21$	
Insulation			Double insulated	
Environmental protection			UV stabilised, flame retardant	
Resistant			Acids, solvents and oils	
Connection			Suitable for screw or lug termination	
Physicals				
Housing			IP 67	
Application			Below / above grade	
Weight			0.5kg approx.	
Operating temperature			- 40°C ... + 80°C	
LIMITATIONS				
Connections		Electrical connections must be terminated in a suitably certified enclosure or safe area		
Service temperature range		- 30°C ... + 70°C		

Ordering information

	350	500
Ordering code EPZ 100/xxx	509 509	509 511

Dimensions

Internal configuration

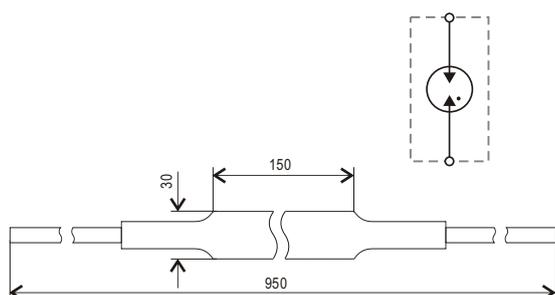

Dimensions, weight and packaging		
EPZ 100/xxx	350	500
Weight per unit	500g	500g
Packaging dimensions (single unit)	310 x 330 x 160 mm	
Min. packaging quantity	20 pcs.	



EPZ 100/xxx Ex



- **Location of use:** Exposed environments or direct burial
- **Protective element:** GDT
- **High surge discharge rating:** $I_{max} = 100kA$
- **Housing:** Corrosion resistant enclosure with hermetic environmental seal and flying leads for ease of connection
- **Type of protection according to ATEX:** Ex nC: hermetically sealed device
- **Complies with:** IEC 61643-11, EN 50164-3:2004



Type	EPZ 100/xxx Ex	
	350	500
Electrical Characteristics		
DC sparkover voltage (100V/s)	U_{dc}	> 280V
Impulse sparkover voltage (1.2/50 μ s, 6kV)	U_p	< 1000V
Max. discharge current (8/20 μ s)	I_{max}	100kA
Impulse discharge current (10/350 μ s)	I_{imp}	25kA
Capacitance at 1MHz	C	< 10pf
Insulation resistance at 100V _{DC}	R	> 1G Ω
Dimensions		
Nom. outer diameter	28mm	
Nom. length	140mm	
Length with cables	1m approx.	
Cable		
Cross sectional area	16mm ²	
Length	450mm approx.	
Number of conductors	$\geq 462/0.21$	
Insulation	Double insulated	
Environmental protection	UV stabilised, flame retardant	
Resistant	Acids, solvents and oils	
Connection	Suitable for screw or lug termination	
Physicals		
Housing	IP 67	
Application	Below / above grade	
Weight	0.5kg approx.	
Operating temperature	- 40°C ... + 80°C	
LIMITATIONS		
Connections	Electrical connections must be terminated in a suitably certified enclosure or safe area	
Service temperature range	- 30°C ... + 70°C	

Ordering information

	350	500
Ordering code EPZ 100/xxx Ex	322 973	322 975

Dimensions

Internal configuration

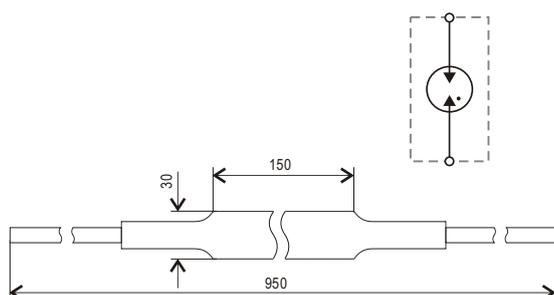

Dimensions, weight and packaging		
EPZ 100/xxx Ex	350	500
Weight per unit	500g	500g
Packaging dimensions (single unit)	310 x 330 x 160 mm	
Min. packaging quantity	20 pcs.	

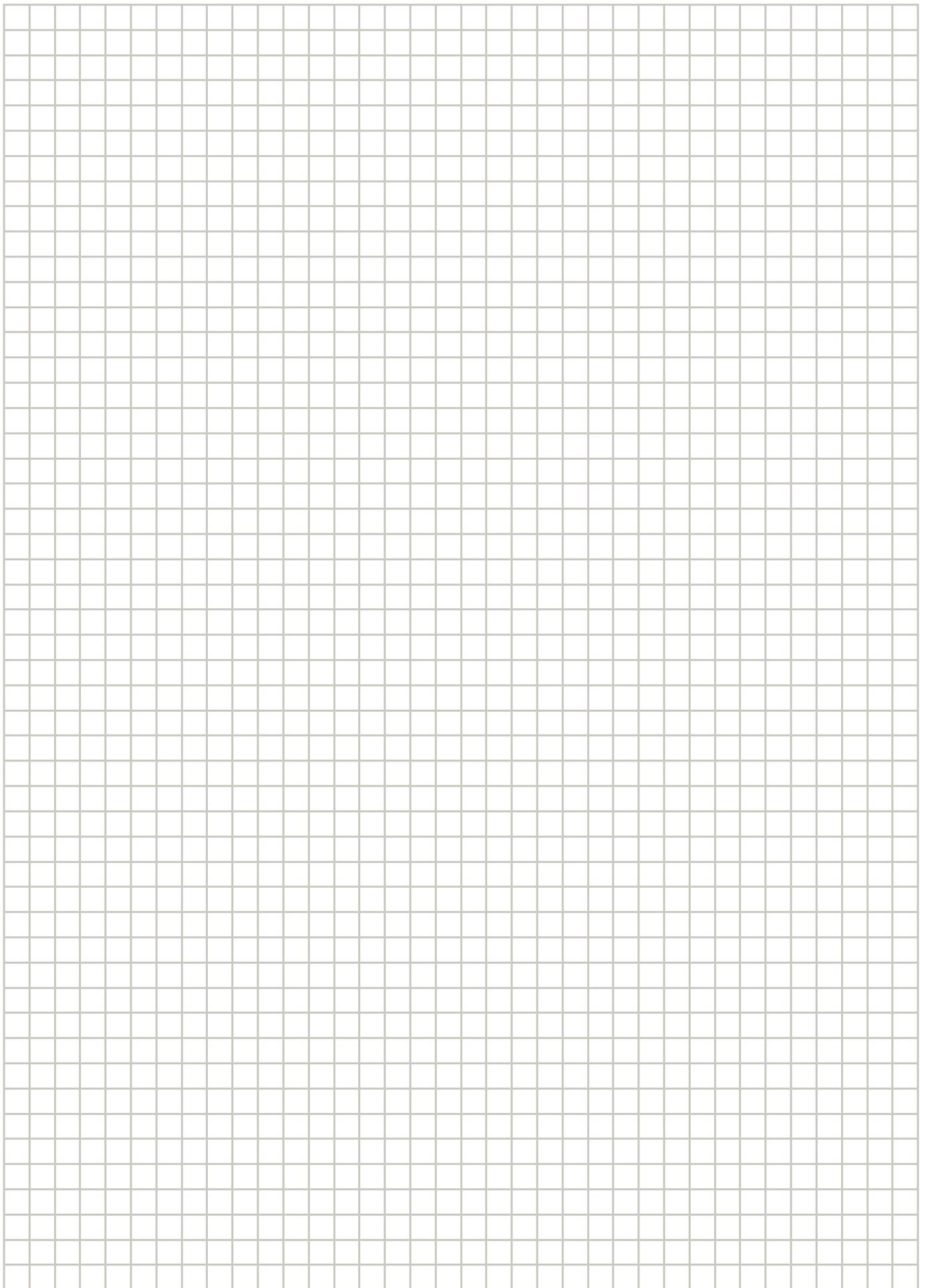

Connection Accessories

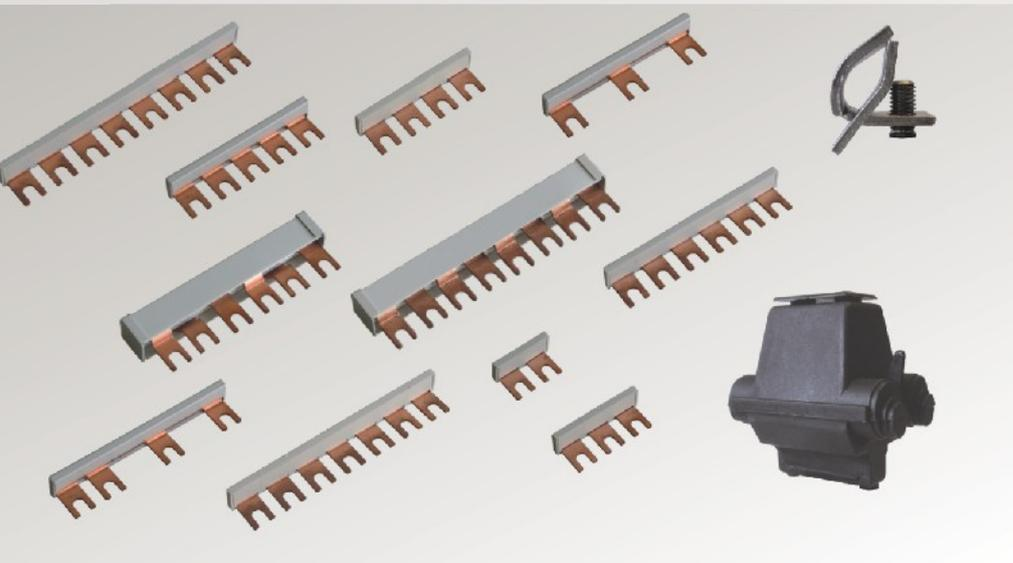

PROSHORT
PRONET S xx
PROBAR Series
Fixing cable
Fixing hook
PSN
PSI

The PROSHORT is an accessory used with the PROTEC family to provide simple through connections when needed to facilitate wiring installations.

The PRONET S decoupling coil has been developed to establish co-ordination between spark-gap lightning arresters (requirement Class I) and varistor-based surge arresters (Class II).

It is only necessary to install the PRONET S if the distance between lightning arrester and surge arrester at the zone interfaces (total line length) is not more than 7 meters.

Probar series of insulated busbar inter-connects for use with DIN rail products.

Fixing cable and fixing hook are used as fastening devices for PROTEC A overhead lines protection series.

PROSHORT



- **Category IEC / EN / VDE:** Class I, II / Type 1, 2 / B, C
- **Location of use:** All kind of distribution boards
- **Housing:** Compact design
- **Complies with:** IEC/EN 61643-11



Technical data

Type		PROSHORT
Electrical characteristics		
Nominal voltage	U_0	230V
Nominal discharge current (8/20)	I_n	100A
Max. discharge current (10/350)	I_{imp}	100kA
Mechanical characteristics		
Temperature range		-40°C ... +80°C
Terminal screw torque		max. 3.0Nm
Terminal cross section		35mm ² (solid) / 25mm ² (stranded)
Mounting		35mm DIN rail, EN 60715
Degree of protection		IP 20
Housing material		Thermoplastic; extinguishing degree UL 94 V-0

Ordering information

Ordering code PROSHORT	501 101
------------------------	---------

Dimensions

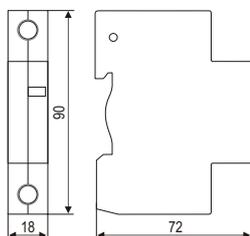

Internal configuration

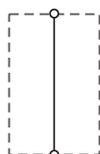

Dimensions, weight and packaging	
PROSHORT	
Dimensions DIN 43880	1TE
Weight per unit	72g
Packaging dimensions (single unit)	108 x 74 x 24mm
Min. packaging quantity	12 pcs.

PRONET S



- **Category IEC / EN / VDE:** Class I / Type 1 / B
- **Location of use:** Main distribution boards
- **Coordination element:** Decoupling coil
- **Nominal current:** $I_n = 35A; 63A$
- **Housing:** Compact housing
- **Complies with:** IEC/EN 61643-11



Technical data

Type	PRONET S xx	
	35	63
Electrical characteristics		
Nominal discharge current (8/20)	I_n	35A
Nominal voltage	U_n	230V
Inductance	L	15µH
Mechanical characteristics		
Temperature range	-40°C ... +80°C	
Terminal screw torque	max. 3.0Nm	
Terminal cross section	35mm ² (solid) / 25mm ² (stranded)	
Mounting	35mm DIN rail, EN 60715	
Degree of protection	IP 20	
Housing material	Thermoplastic; extinguishing degree UL 94 V-0	

Ordering information

I_n	35	63
Ordering code PRONET S xx	501 001	501 003

Dimensions

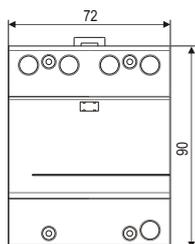
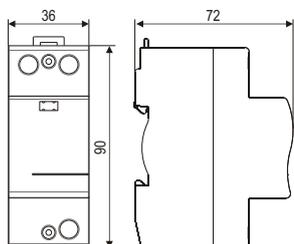

Internal configuration

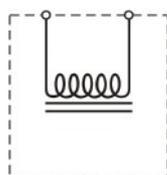

Dimensions, weight and packaging		
PRONET S xx	35	63
Dimensions DIN 43880	2TE	4TE
Weight per unit	438g	541g
Packaging dimensions (single unit)	109 x 76.5 x 41.5mm	109 x 76.5 x 78mm
Min. packaging quantity	7 pcs.	3 pcs.

Single-phase busbars

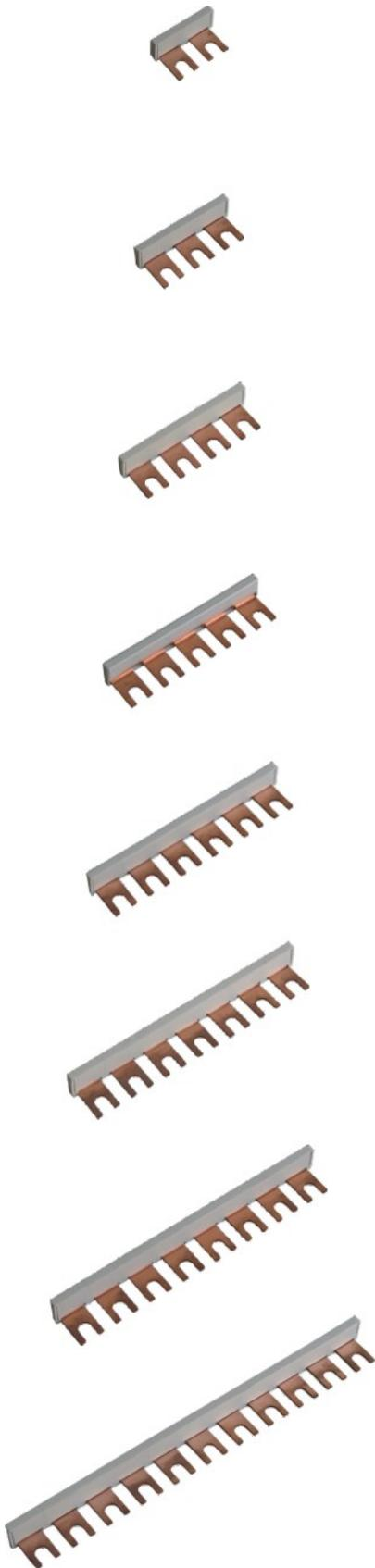

Ordering informations

Type	
PROBAR	1-2
No. of poles	2
Busbar cross-section	16mm ²
Ordering code	501 301

Type	
PROBAR	1-3
No. of poles	3
Busbar cross-section	16mm ²
Ordering code	501 303

Type	
PROBAR	1-4
No. of poles	4
Busbar cross-section	16mm ²
Ordering code	501 305

Type	
PROBAR	1-5
No. of poles	5
Busbar cross-section	16mm ²
Ordering code	501 307

Type	
PROBAR	1-6
No. of poles	6
Busbar cross-section	16mm ²
Ordering code	501 309

Type	
PROBAR	1-7
No. of poles	7
Busbar cross-section	16mm ²
Ordering code	501 311

Type	
PROBAR	1-8
No. of poles	8
Busbar cross-section	16mm ²
Ordering code	501 313

Type	
PROBAR	1-11
No. of poles	11
Busbar cross-section	16mm ²
Ordering code	501 315

Two-phase busbars



Ordering informations

Type	
PROBAR	2-8
No. of poles	8
Busbar cross-section	16mm ²
Ordering code	501 317

Three-phase busbars

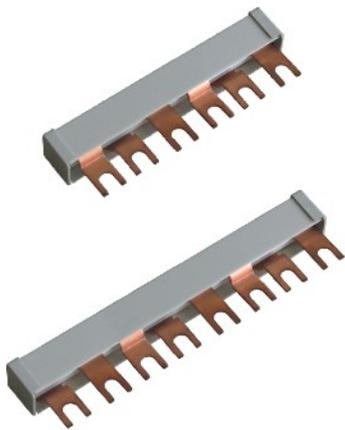

Ordering informations

Type	
PROBAR	3-6
No. of poles	6
Busbar cross-section	16mm ²
Ordering code	501 319

Type	
PROBAR	3-8
No. of poles	8
Busbar cross-section	16mm ²
Ordering code	501 321

Single-phase busbars

PROTEC BS(R) - 2TE, SAFETEC B(R) - 2TE

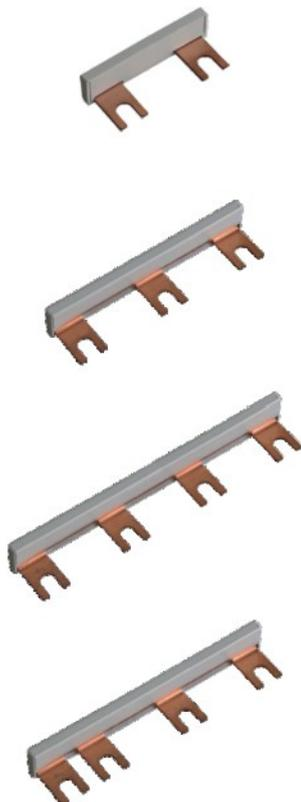

Ordering informations

Type	
PB	1-(2+0)
No. of poles	2
Busbar cross-section	16mm ²
Ordering code	501 331

Type	
PB	1-(3+0)
No. of poles	3
Busbar cross-section	16mm ²
Ordering code	501 332

Type	
PB	1-(4+0)
No. of poles	4
Busbar cross-section	16mm ²
Ordering code	501 335

Type	
PB	1-(3+1)
No. of poles	4
Busbar cross-section	16mm ²
Ordering code	501 334

Connection parts for PROTEC AQ and AQS Series

Ordering informations



Type	Fixing cable
Ordering code	509 507



Type	Fixing hook
Ordering code	509 501



Type	PSN (Connection clamp for non insulated conductor)
Ordering code	509 503



Type	PSI (Connection clamp for insulated conductor)
Ordering code	509 505

ProGRID Series - Power Quality Accessories



Surge and Lightning counter Family

- ProSEC I
 - ProSEC II+
 - ProSEC III
 - ProLEC
- } COMING SOON

Surge is a high frequency current event. For any kind of electrical device it presents a potentially dangerous event and can occur in electrical network for number of reasons. The most common cause is a lightning strike, but also switching of inductive loads, operation of industrial equipment, power grid disturbances and general fault or arcing conditions are all capable of producing a surge pulse. In case of a direct lightning strike the damage, caused by surge current, is sometimes clearly felt and visible, but most of other events go by unnoticed. Consequences of such 'quiet' disturbances are not always negligible.

Surge currents can cause loss of data transmission, switch tripping, disturbance of a machine control systems or a slow but noticeable degradation of circuit elements. On the other hand, a surge can be an indicator of a short circuit, inrush currents of power load after a blackout or wiring insulation damage.

The ProSEC family is a series of surge counters with different capabilities that sense and record the otherwise undetectable surge currents. This enables users to take preventive measures and plan maintenance.

SPD Life-status Monitoring Accessories

- ProALARM I
 - ProALARM II
 - ProSLS
 - ProALYSER
 - ProSTE
- } COMING SOON

Surge Protective Devices (SPDs) are designed to be self-sacrificial, often failing in order to protect more expensive equipment downstream. SPDs will typically withstand one large surge of their I_{max} (class II) or I_{imp} (class I) rating, or many smaller surges. In essence, their life is based on the magnitude and frequency of surges they have diverted. This means, that at some point in time, they will reach the end of their life cycle. This may be due to many small surges, or one large surge which exceeds the specified rating of the SPD. Upon reaching end-of-life, a correctly designed SPD will safely "disconnect" itself from the power supply and equipment is there to protect. Such disconnection usually goes unnoticed, since it is reported only with a visual indication directly on the SPD, which because of its longevity is usually not inspected frequently enough.

With our new SPD life status indication devices, we are making it easier for user to get the information about a failed SPD device immediately, or more importantly, to get a warning when a SPD is nearing its end-of-life. With that, power supply network will never be without SPD protection, which is as important as having the SPD installed in the first place.



ProSEC I



- Mechanical counter
- Self-energizing, no battery power needed
- Permanent record of surge events, non-resettable
- Sensor inside of counter enclosure, uses power contacts for connection
- Sensing surge currents as low as 100A (8/20 μ s)
- Complies with: IEC/EN 62561-6



Technical data

Type	ProSEC I	
Electrical characteristics		
Threshold current (8/20)	I_{tc}	100A
Max. counting discharge current (8/20)	I_{mcw}	30kA
Mechanical counter		0 - 999
Mechanical characteristics		
Temperature range		- 10°C ... + 60°C
Degree of protection		IP 20
Housing material		Thermoplastic; extinguishing degree UL 94 V-0
Mounting		35mm DIN rail, EN 60715

Installation example

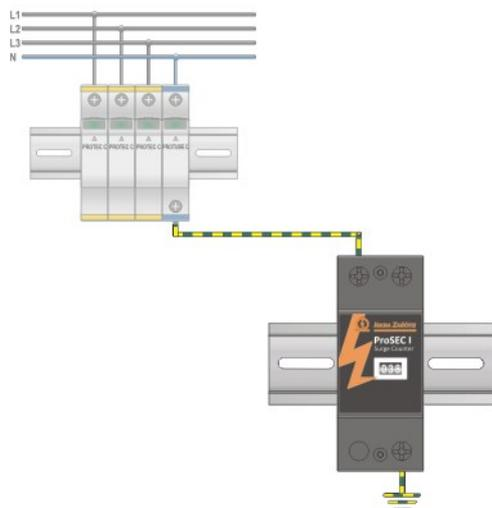

ProSEC I is a surge counter. For its operation it does not need any power supply so no maintenance is needed. It is a simple device, made to sense the lowest surge currents that can disturb the power supply inside a building. It is not possible to reset or set it in any way.

Ordering information

Ordering code ProSEC I	130 090
------------------------	---------

Dimensions

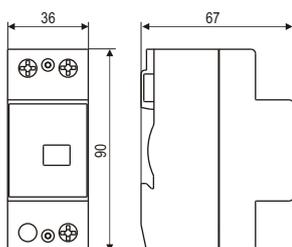

Dimensions, weight and packaging	
ProSEC I	
Dimensions DIN 43880	2TE
Weight per unit	140g
Packaging dimensions (single unit)	109 x 76.5 x 41.5mm

ProSEC II+



- LCD screen that shows number of surges, hour and date of surge event
- Buttons for TIME/DATE setting and log viewing
- Replacable battery, battery life minimum 4 years
- Easy to install, Snap-on surge current sensor
- Complies with: IEC/EN 62561-6, 61326-1



Technical data

Type	ProSEC II+	
Electrical characteristics		
Threshold current (8/20)	I_{tc}	50A
Max. counting discharge current (8/20)	I_{mcw}	50kA
Number of event logged		999
Mechanical characteristics		
Temperature range		- 20°C ... + 70°C
Degree of protection		IP 20
Housing material		Thermoplastic; extinguishing degree UL 94 V-0
Mounting		35mm DIN rail, EN 60715
Replacable battery (CR123A)		4 years
Max. wired diameter through the current sensor		14mm
Sensor cable		0.5m

Installation example

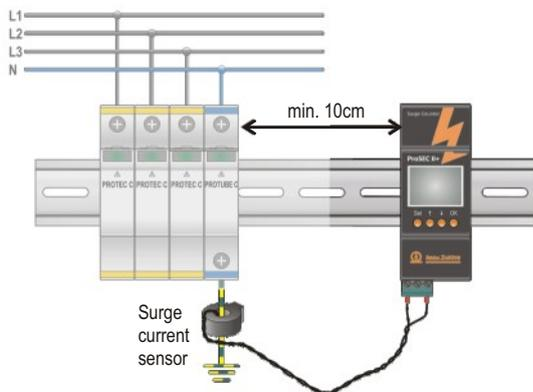

ProSEC II+ is a surge counter with an extra function. Beside surge number count it also logs hour and date for each surge counted. Its surge count and log of previous surges cannot be tempered with, so it can be used for cooperation with insurance companies. With additional time and date logging function, it is now possible to pinpoint the exact time of every surge and correlate it with equipment and power supply problems inside of building.

Ordering information

Ordering code ProSEC II+	130 092
--------------------------	---------

Dimensions

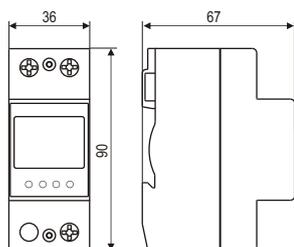

Dimensions, weight and packaging	
ProSEC II+	
Dimensions DIN 43880	2TE
Weight per unit	150g
Packaging dimensions (single unit)	110 x 83 x 42mm

ProSEC III



- Color LCD
- Surge counter displaying and logging time/date and current amplitude data
- Remote contact event warning
- "SPD check" warning
- Complies with: IEC/EN 62561-6, 61326-1



Technical data

Type	ProSEC III	
Electrical characteristics		
Threshold current (8/20)	I_{tc}	1kA
Max. counting discharge current (8/20)	I_{mcw}	50kA
Power supply		85 - 264V _{AC} , 100 - 400V _{DC}
Number of stored events		999
Current amplitude resolution		0.5kA
Mechanical characteristics		
Temperature range		- 20°C ... + 60°C
Degree of protection		IP 20
Housing material		Thermoplastic; extinguishing degree UL 94 V-0
Mounting		35mm DIN rail, EN 60715
Max. wired diameter through the current sensor		11mm
Sensor cable		0.5m

Installation example

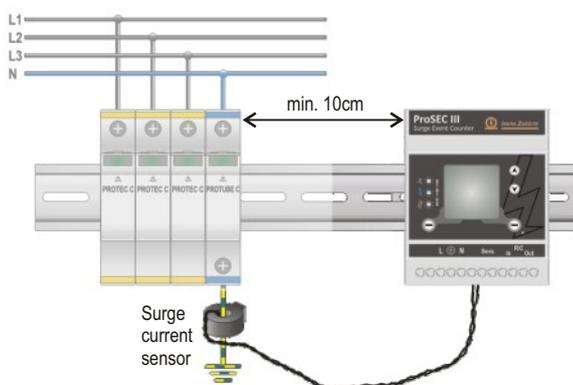

ProSEC III is the new surge current counter, the only one with possibility, to not only sense and log time and date of a surge current event, but to also measure its amplitude. With ProSEC III counter the cause of surge current becomes much more obvious. Therefore, the prediction of possible consequences caused by surges, are easier to assess. We can now make a complete analysis of surge events source and type at the place of measurement and take appropriate precautions and repairs that will keep our equipment and electrical power network in working order.

Ordering information

Ordering code ProSEC III	130 601
---------------------------------	----------------

Dimensions

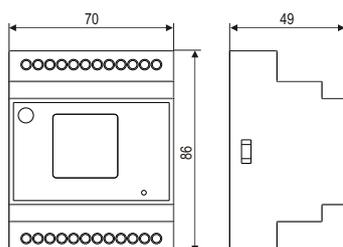

Dimensions, weight and packaging	
ProSEC II+	
Dimensions DIN 43880	4TE
Weight per unit	230g
Packaging dimensions (single unit)	109 x 76.5 x 96mm

ProLEC I



- Color LCD
- Surge counter displaying and logging time/date and current amplitude data
- Remote contact event warning
- Complies with: IEC/EN 62561-6, 61326-1



Technical data

Type	ProLEC I	
Electrical characteristics		
Threshold current (10/350)	I_{tc}	1kA
Max. withstand current (10/350)	I_{mcw}	100kA
Number of event logged		999
Current amplitude resolution		5kA
Mechanical characteristics		
Temperature range		- 20°C ... + 70°C
Degree of protection		IP 65
Housing material		Alu
Mounting		Directly on down-conductor

Installation example



ProLEC I is the first in line of the new lightning current sensors family. It is meant to be used for sensing, measuring and logging lightning discharges that flow through lightning protection systems. ProLEC device is installed directly on lightning down conductor. It is made to withstand currents up to 100kA (10/350). By installing ProLEC on a building's lightning protection system, we gain the knowledge of frequency, magnitude and exact time/date of atmospheric discharges that affected the object. Preventive or maintenance measures can be taken accordingly, depending on information gained from the counter.

Ordering information

Ordering code ProLEC I	130 520
------------------------	---------

Dimensions

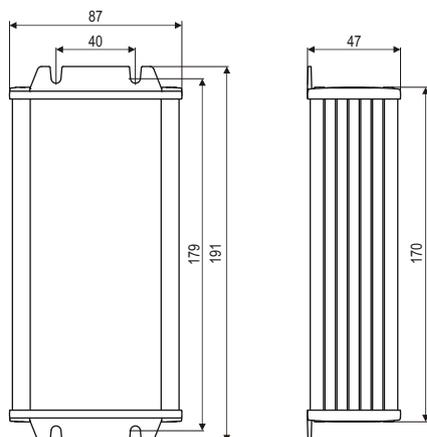

Dimensions, weight and packaging	
ProLEC I	
Dimensions	191 x 87 x 47mm
Weight per unit	420g

ProALARM I



- **Audio alarm (60dB) for SPD failure indication**
- **Multicolored LED:** **GREEN** (SPD and ProALARM in good order)
RED (Replace SPD)
ORANGE (Battery low)
- **Button to acknowledge and silence alarm**
- **Remote connections to SPD**
- **Battery supply** (approximately 8 years lifetime)



Technical data

Type	ProALARM I
Mechanical characteristics	
Temperature range	- 20°C ... + 70°C
Degree of protection	IP 20
Housing material	Thermoplastic; extinguishing degree UL 94 V-0
Mounting	35mm DIN rail, EN 60715

Installation example

ProALARM is a simple SPD failure indicating device, which informs the user of the need to replace a failed protection device when necessary. It can be quickly and easily installed without the need for connection to a remote control device. User is notified with a discrete beeping sound that can be acknowledged and deactivated.

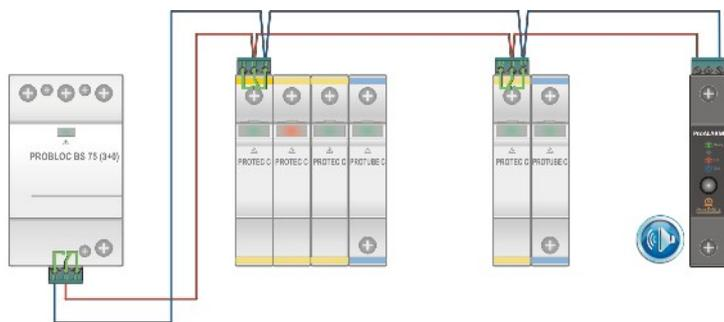

Ordering information

Ordering code ProALARM I	130 510
--------------------------	---------

Dimensions

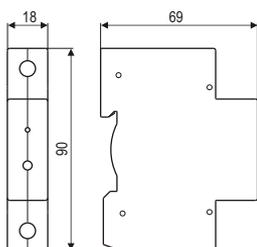

Dimensions, weight and packaging	
ProALARM I	
Dimensions DIN 43880	1TE
Weight per unit	80g
Packaging dimensions (single unit)	108 x 74 x 24mm

ProALARM II



- Easy to use 'RC (remote contacts) to Ethernet' device
- Monitoring RC outputs of 8 individual devices
- Device status accessible through WEB user interface
- Device status alarm through email
- Additional power supply module is needed (5-30V DC)
- Complies with: IEC/EN 62561-6



Technical data

Type	ProALARM II
Electrical characteristics	
Communication	Ethernet
Power supply (DC)	5V - 30V
Max. number of directly connected devices	8
Mechanical characteristics	
Temperature range	- 40°C ... + 85°C
Degree of protection	IP 20
Housing material	Thermoplastic; extinguishing degree UL 94 V-0
Mounting	35mm DIN rail, EN 60715

Installation example

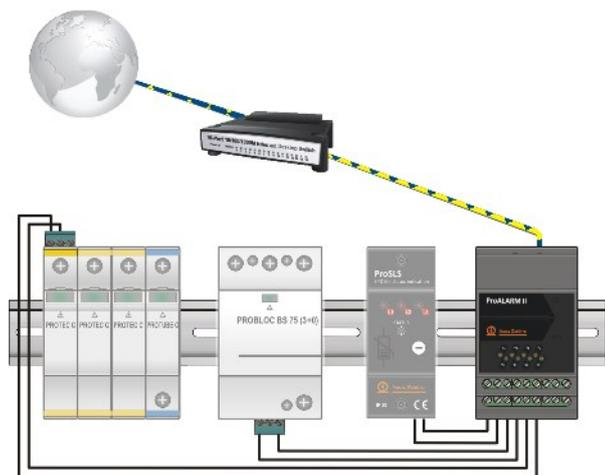

ProALARM II is a purpose designed alarm monitoring device, which interfaces with remote contact outputs RC, from many of the products designed by Iskra Zaščite. This monitoring information is conveyed by ProALARM II unit to end-user, or centralized facility monitoring system, by means of a WEB user interface.

ProALARM II can monitor up to 8 individual devices.

As a member of the Iskra ProGRID series of power quality devices, it is designed to monitor associated devices, such as ProSLS or and SPD device with RC option.

Also other devices that provide voltage-free RC contacts, such as building and fire Alarms, can be monitored with ProALARM II.

Ordering information

Ordering code ProALARM II	130 560
---------------------------	---------

Dimensions

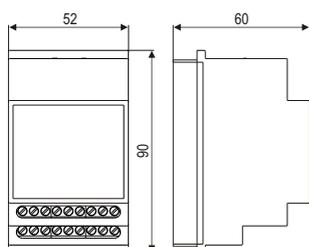

Dimensions, weight and packaging	
ProALARM II	
Dimensions DIN 43880	3TE
Weight per unit	140g
Packaging dimensions (single unit)	106 x 73.5 x 58mm

ProSLS



- Automatic adjustment to all SPD sizes and models
- Sensing zero leakage current of a disconnected SPD
- Compatible with ProALARM II 'communication over ethernet' device
- Three states indication: SPD OK, Change Needed, Failed
- Complies with: IEC/EN 61326-1



Technical data

Type	ProSLS
Electrical characteristics	
Lowest measurable current	100µA
Mechanical characteristics	
Temperature range	- 30°C ... + 70°C
Degree of protection	IP 20
Housing material	Thermoplastic; extinguishing degree UL 94 V-0
Mounting	35mm DIN rail, EN 60715
Replacable battery (CR2477)	8 years
Remote contacts	1A, 125V _{AC} /30V _{DC}

Installation example

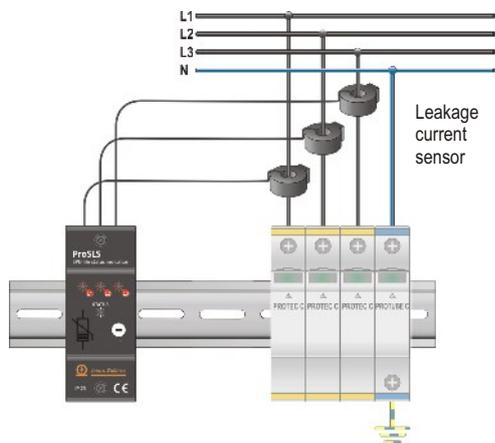

ProSLS is a device, that continuously monitors SPD's leakage current, the most accurate predictor of an SPD's life status. According to measured current, ProSLS is able to predict the advanced degradation or a sudden failure of SPD and convey this information to the user.

With a set of remote contacts, ProSLS can be connected to ProALARM II, thus warning the user about SPD state through a web interface.

Ordering information

Ordering code ProSLS	130 550
-----------------------------	---------

Dimensions

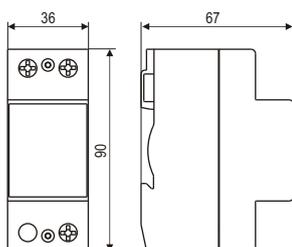

Dimensions, weight and packaging	
ProSLS	
Dimensions DIN 43880	2TE
Weight per unit	180g
Packaging dimensions (single unit)	106 x 73.5 x 58mm

ProAlyser



- SPD life status and failure indication
- Surge counter, measuring surge amplitude, logging Time/Date of event
- Logging of power quality events
- On-line measuring of electric supply parameters



Technical data

Type	ProAlyser
Mechanical characteristics	
Temperature range	- 20°C ... + 70°C
Degree of protection	IP 20
Housing material	Thermoplastic; extinguishing degree UL 94 V-0
Mounting	35mm DIN rail, EN 60715

Installation example

ProAlyser is an advanced SPD status indicator, 3-phase power analyzer and power quality indicator. The device is a powerful but simple to use tool for a complete overview of power supply in a building. Its main function though is an on-line monitoring of surge protection modules life status.

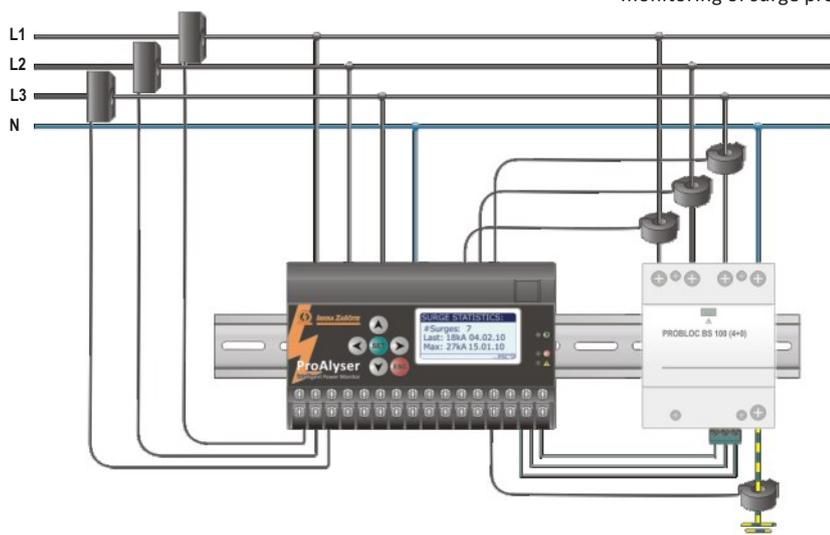

Ordering information

Ordering code ProAlyser	130 500
-------------------------	---------

Dimensions

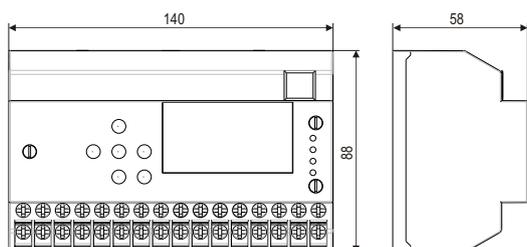

Dimensions, weight and packaging	
ProAlyser	
Dimensions DIN 43880	8TE
Weight per unit	580g
Packaging dimensions (single unit)	147 x 109 x 76.5mm

SLS (SPD Life Status)

- Three phase SPD monitoring
- Percentage Residual SPD Life - 100% to 0%
- Warning each 10% degradation of Residual SPD Life
- Critical Visual and Audible alarm for permanent SPD disconnection, or when Life Status < 30%

SPD	L1	L2	L3
R/C:	✓	✓	X
I mA:	23	16	0
Life%:	50	70	0

...ESC →

SURGE COUNTER

- Visual notification that a surge event has occurred
- Records:
 - Date (dd:mm:yy)
 - Time (hh:mm:ss)
 - Surge amplitude (kA)
- Logging of last 10 events in non-volatile memory
- Running total of number of surges and highest surge recorded

SURGE STATISTICS:

#Surges: 7
Last: 18kA 04.02.10
Max: 27kA 15.01.10

...ESC →

SRG Event: #12

Surge: 26.6kA
Time: 23:21:44
Date: 2.2.2010

←CLR... ..ESC →

POWER QUALITY INDICATOR

- Log of Temporary Overvoltages (Vn + 10%)
- Records:
 - Date (dd:mm:yy)
 - Time (hh:mm:ss)
 - Peak voltage (v)
- Log of Voltage Sags (Brownouts)
- Records:
 - Date (dd:mm:yy)
 - Time (hh:mm:ss)
- Log of Power Failures
- Records:
 - Date (dd:mm:yy)
 - Time (hh:mm:ss)
- Log of Network parameters
- Records:
 - MIN/MAX values (V, I, W, Hz, PF) per phase

LOGGED Data:

- ▶ SURGE Events
- OVER Voltages
- UNDER Voltages
- SPD Leakage
- SPD R/Cs
- PWR Failures

TOV Event: #14

Vpk: 388.9V
Time: 11:15:24
Date: 7.1.2010

←CLR... ..ESC →

P/F Event: #8

Power failure:
Time: 17:48:22
Date: 11.1.2010

←CLR... ..ESC →

3-PHASE POWER METER (PER PHASE)

- Voltage (VRSM)
- Current (IRMS)
- Frequency (Hz)
- Power Pactor (Cos Phi)
- Peak Voltage (Vpk)
- Energy Measurment (kWh, kVARh, kVAh)
- REMOTE INTERFACE RS232 SERIAL LINK AND MONITORING APPLICATION (PROPAC Software)**
- Real-time monitor
- Last five alarms and measurments
- Graphical data preview
- History log of alarms and measurments

SYSTEM ANALYSIS

uRMS :	224.4	V
iRMS :	9.8	A
Freq :	50.0	Hz
Pwr :	2199.1	W
Cos :	0.98	pf
VPk :	325.6	V
P :	185.3	kWh
Q :	19.2	kVARh
S :	186.3	kVAh

ProSTE



- 10/100Mbps Ethernet
- TCP/UDP/Telnet modes
- DHCP/Static IP modes
- Web or AT command based configuration
- Industrial Temperature Range (-40°C to 85°C)
- Standard and custom baud rates with factory application
- RS-232 capability



Technical data

Type	ProSTE
Communication	RS232 to Ethernet
Input	110 - 240VAC / 50 (60Hz)
Mechanical characteristics	
Temperature range	- 40°C ... + 85°C
Degree of protection	IP 20
Housing material	Thermoplastic; extinguishing degree UL 94 V-0
Mounting	35mm DIN rail, EN 60715

Installation example

ProSTE is a Serial-to-Ethernet unit designed to allow legacy industrial devices with only RS232 serial outputs to be directly accessible via an Ethernet connection. This allows monitoring and control of such devices from any network location or even via the Internet.

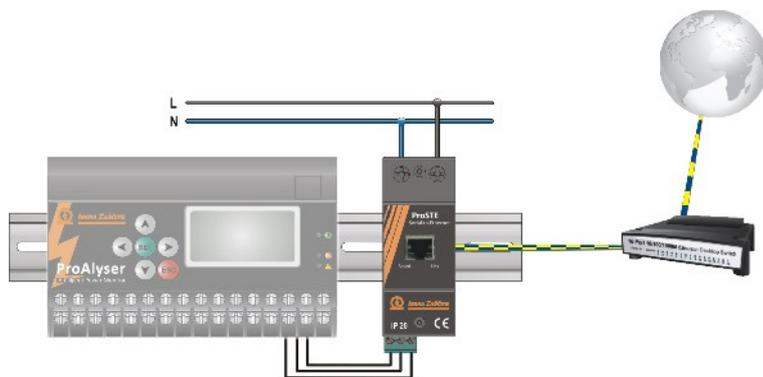

Ordering information

Ordering code ProSTE	130 530
----------------------	---------

Dimensions

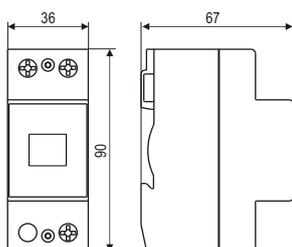

Dimensions, weight and packaging	
ProSTE	
Dimensions DIN 43880	2TE
Weight per unit	170g
Packaging dimensions (single unit)	109 x 76.5 x 41.5mm

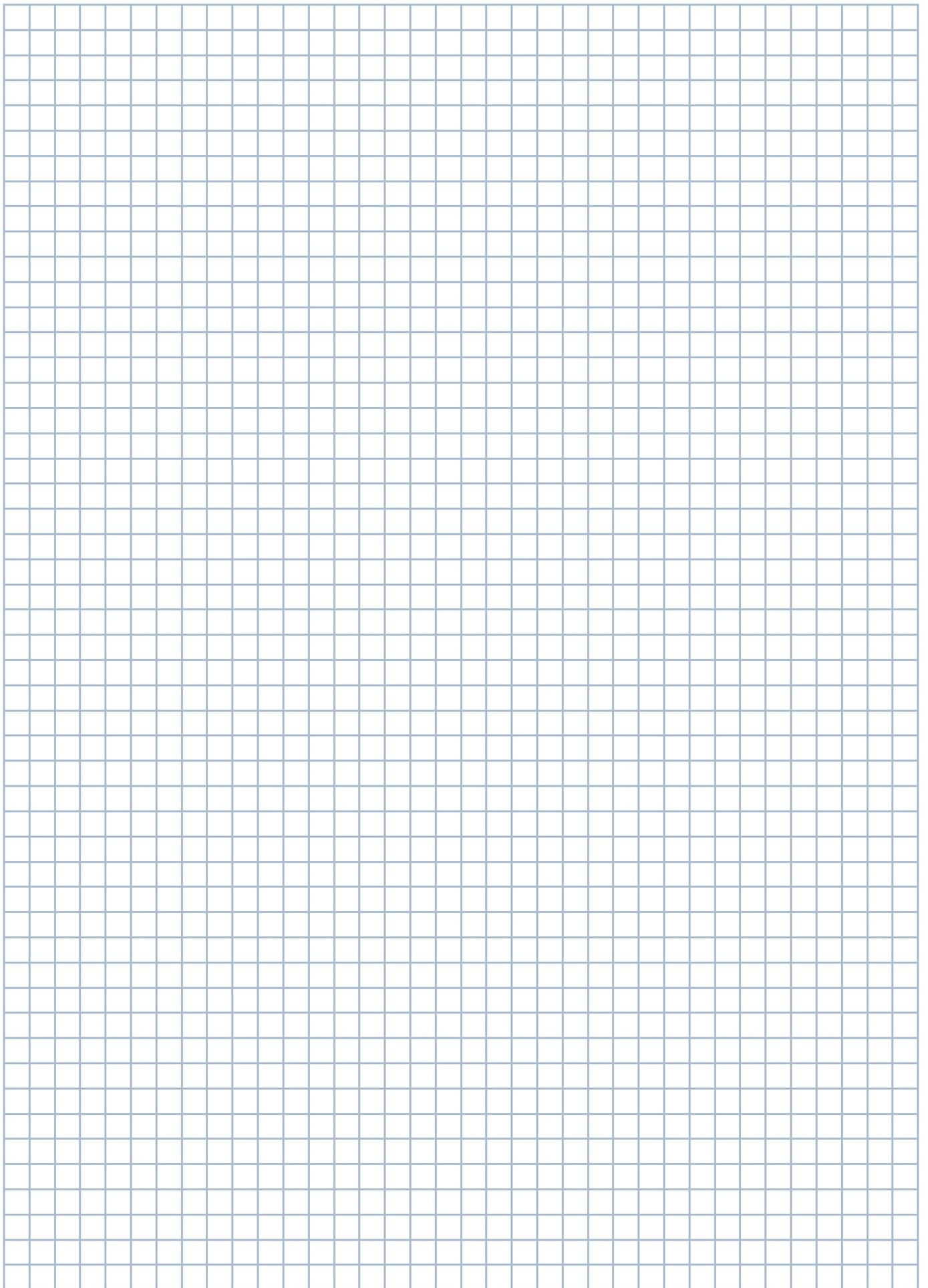

Product name	Ordering code	Dimensions DIN 43880	Packaging dimensions (single unit)	Minimum packaging quantity	Weight	Page	
Class I, II Compact Single and Multi-pole SPD 12.5kA per pole							
	SAFETEC B 12.5/150 TCG	54.0146	2TE	109 x 76.5 x 41.5mm	7 pcs.	175g	12
	SAFETEC BR 12.5/150 TCG	54.0147	2TE	109 x 76.5 x 41.5mm	7 pcs.	180g	12
	SAFETEC B 12.5/275 TCG	54.0148	2TE	109 x 76.5 x 41.5mm	7 pcs.	205g	12
	SAFETEC BR 12.5/275 TCG	54.0149	2TE	109 x 76.5 x 41.5mm	7 pcs.	210g	12
	SAFETEC B 12.5/440 TCG	54.0150	2TE	109 x 76.5 x 41.5mm	7 pcs.	255g	12
	SAFETEC BR 12.5/440 TCG	54.0151	2TE	109 x 76.5 x 41.5mm	7 pcs.	260g	12
	SAFETUBE B 50	54.0006	2TE	108 x 76.5 x 41.5mm	7 pcs.	180g	13
	SAFELOC B 25/150 (2+0) TCG	54.0152	4TE	109 x 76.5 x 78mm	3 pcs.	320g	15
	SAFELOC BR 25/150 (2+0) TCG	54.0153	4TE	109 x 76.5 x 78mm	3 pcs.	330g	15
	SAFELOC B 25/275 (2+0) TCG	54.0154	4TE	109 x 76.5 x 78mm	3 pcs.	420g	15
	SAFELOC BR 25/275 (2+0) TCG	54.0155	4TE	109 x 76.5 x 78mm	3 pcs.	430g	15
	SAFELOC B 25/440 (2+0) TCG	54.0156	4TE	109 x 76.5 x 78mm	3 pcs.	540g	15
	SAFELOC BR 25/440 (2+0) TCG	54.0157	4TE	109 x 76.5 x 78mm	3 pcs.	550g	15
	SAFELOC B 37.5/150 (3+0) TCG	54.0164	6TE	109 x 76.5 x 148mm	2 pcs.	430g	15
	SAFELOC BR 37.5/150 (3+0) TCG	54.0165	6TE	109 x 76.5 x 148mm	2 pcs.	435g	15
	SAFELOC B 37.5/275 (3+0) TCG	54.0166	6TE	109 x 76.5 x 148mm	2 pcs.	530g	15
	SAFELOC BR 37.5/275 (3+0) TCG	54.0167	6TE	109 x 76.5 x 148mm	2 pcs.	535g	15
	SAFELOC B 37.5/440 (3+0) TCG	54.0168	6TE	109 x 76.5 x 148mm	2 pcs.	740g	15
	SAFELOC BR 37.5/440 (3+0) TCG	54.0169	6TE	109 x 76.5 x 148mm	2 pcs.	745g	15
	SAFELOC B 50/150 (4+0) TCG	54.0170	8TE	109 x 76.5 x 148mm	2 pcs.	800g	15
	SAFELOC BR 50/150 (4+0) TCG	54.0171	8TE	109 x 76.5 x 148mm	2 pcs.	820g	15
	SAFELOC B 50/275 (4+0) TCG	54.0172	8TE	109 x 76.5 x 148mm	2 pcs.	1000g	15
	SAFELOC BR 50/275 (4+0) TCG	54.0173	8TE	109 x 76.5 x 148mm	2 pcs.	1020g	15
	SAFELOC B 50/440 (4+0) TCG	54.0174	8TE	109 x 76.5 x 148mm	2 pcs.	1160g	15
	SAFELOC BR 50/440 (4+0) TCG	54.0175	8TE	109 x 76.5 x 148mm	2 pcs.	1080g	15
	SAFELOC B 25/150 (1+1) TCG	54.0158	4TE	109 x 76.5 x 78mm	3 pcs.	280g	17
	SAFELOC BR 25/150 (1+1) TCG	54.0159	4TE	109 x 76.5 x 78mm	3 pcs.	285g	17
	SAFELOC B 25/275 (1+1) TCG	54.0160	4TE	109 x 76.5 x 78mm	3 pcs.	315g	17
	SAFELOC BR 25/275 (1+1) TCG	54.0161	4TE	109 x 76.5 x 78mm	3 pcs.	320g	17
	SAFELOC B 25/440 (1+1) TCG	54.0162	4TE	109 x 76.5 x 78mm	3 pcs.	340g	17
	SAFELOC BR 25/440 (1+1) TCG	54.0163	4TE	109 x 76.5 x 78mm	3 pcs.	345g	17
	SAFELOC B 50/150 (3+1) TCG	54.0176	8TE	109 x 76.5 x 148mm	2 pcs.	785g	17
	SAFELOC BR 50/150 (3+1) TCG	54.0177	8TE	109 x 76.5 x 148mm	2 pcs.	800g	17
	SAFELOC B 50/275 (3+1) TCG	54.0178	8TE	109 x 76.5 x 148mm	2 pcs.	900g	17
	SAFELOC BR 50/275 (3+1) TCG	54.0179	8TE	109 x 76.5 x 148mm	2 pcs.	915g	17
	SAFELOC B 50/440 (3+1) TCG	54.0180	8TE	109 x 76.5 x 148mm	2 pcs.	1020g	17
	SAFELOC BR 50/440 (3+1) TCG	54.0181	8TE	109 x 76.5 x 148mm	2 pcs.	1035g	17
Class I, II Compact Single and Multi-pole SPD 25kA per pole							
	SAFETEC B 25/150 TCG	54.0038	2TE	109 x 76.5 x 78mm	7 pcs.	275g	22
	SAFETEC BR 25/150 TCG	54.0039	2TE	109 x 76.5 x 78mm	7 pcs.	280g	22
	SAFETEC B 25/275 TCG	54.0040	2TE	109 x 76.5 x 78mm	7 pcs.	325g	22
	SAFETEC BR 25/275 TCG	54.0041	2TE	109 x 76.5 x 78mm	7 pcs.	330g	22
	SAFETEC B 25/440 TCG	54.0042	2TE	109 x 76.5 x 78mm	7 pcs.	375g	22
	SAFETEC BR 25/440 TCG	54.0043	2TE	109 x 76.5 x 78mm	7 pcs.	380g	22
	SAFETUBE B 50	54.0006	2TE	108 x 76.5 x 41.5mm	7 pcs.	180g	23
	SAFETUBE B 100	54.0007	2TE	108 x 76.5 x 41.5mm	7 pcs.	240g	23
	SAFELOC B 50/150 (2+0) TCG	54.0044	4TE	109 x 76.5 x 78mm	3 pcs.	520g	25
	SAFELOC BR 50/150 (2+0) TCG	54.0045	4TE	109 x 76.5 x 78mm	3 pcs.	530g	25
	SAFELOC B 50/275 (2+0) TCG	54.0046	4TE	109 x 76.5 x 78mm	3 pcs.	620g	25
	SAFELOC BR 50/275 (2+0) TCG	54.0047	4TE	109 x 76.5 x 78mm	3 pcs.	630g	25
	SAFELOC B 50/440 (2+0) TCG	54.0048	4TE	109 x 76.5 x 78mm	3 pcs.	740g	25
	SAFELOC BR 50/440 (2+0) TCG	54.0049	4TE	109 x 76.5 x 78mm	3 pcs.	750g	25
	SAFELOC B 75/150 (3+0) TCG	54.0056	6TE	109 x 76.5 x 148mm	2 pcs.	780g	25
	SAFELOC BR 75/150 (3+0) TCG	54.0057	6TE	109 x 76.5 x 148mm	2 pcs.	795g	25
	SAFELOC B 75/275 (3+0) TCG	54.0058	6TE	109 x 76.5 x 148mm	2 pcs.	930g	25
	SAFELOC BR 75/275 (3+0) TCG	54.0059	6TE	109 x 76.5 x 148mm	2 pcs.	945g	25
	SAFELOC B 75/440 (3+0) TCG	54.0060	6TE	109 x 76.5 x 148mm	2 pcs.	1095g	25
	SAFELOC BR 75/440 (3+0) TCG	54.0061	6TE	109 x 76.5 x 148mm	2 pcs.	1110g	25
	SAFELOC B 100/150 (4+0) TCG	54.0062	8TE	109 x 76.5 x 148mm	2 pcs.	1040g	25
	SAFELOC BR 100/150 (4+0) TCG	54.0063	8TE	109 x 76.5 x 148mm	2 pcs.	1060g	25
	SAFELOC B 100/275 (4+0) TCG	54.0064	8TE	109 x 76.5 x 148mm	2 pcs.	1240g	25
	SAFELOC BR 100/275 (4+0) TCG	54.0065	8TE	109 x 76.5 x 148mm	2 pcs.	1260g	25
	SAFELOC B 100/440 (4+0) TCG	54.0066	8TE	109 x 76.5 x 148mm	2 pcs.	1460g	25
	SAFELOC BR 100/440 (4+0) TCG	54.0067	8TE	109 x 76.5 x 148mm	2 pcs.	1480g	25
	SAFELOC B 50/150 (1+1) TCG	54.0050	4TE	109 x 76.5 x 78mm	3 pcs.	475g	27
	SAFELOC BR 50/150 (1+1) TCG	54.0051	4TE	109 x 76.5 x 78mm	3 pcs.	480g	27

	Product name	Ordering code	Dimensions DIN 43880	Packaging dimensions (single unit)	Minimum packaging quantity	Weight	Page	
	SAFEBLOC B 50/275 (1+1) TCG	54.0052	4TE	109 x 76.5 x 78mm	3 pcs.	515g	27	
	SAFEBLOC BR 50/275 (1+1) TCG	54.0053	4TE	109 x 76.5 x 78mm	3 pcs.	520g	27	
	SAFEBLOC B 50/440 (1+1) TCG	54.0054	4TE	109 x 76.5 x 78mm	3 pcs.	565g	27	
	SAFEBLOC B R 50/440 (1+1) TCG	54.0055	4TE	109 x 76.5 x 78mm	3 pcs.	570g	27	
	SAFEBLOC B 100/150 (3+1) TCG	54.0068	8TE	109 x 76.5 x 148mm	2 pcs.	985g	28	
	SAFEBLOC BR 100/150 (3+1) TCG	54.0069	8TE	109 x 76.5 x 148mm	2 pcs.	1000g	28	
	SAFEBLOC B 100/275 (3+1) TCG	54.0070	8TE	109 x 76.5 x 148mm	2 pcs.	1135g	28	
	SAFEBLOC BR 100/275 (3+1) TCG	54.0071	8TE	109 x 76.5 x 148mm	2 pcs.	1150g	28	
	SAFEBLOC B 100/440 (3+1) TCG	54.0072	8TE	109 x 76.5 x 148mm	2 pcs.	1285g	28	
	SAFEBLOC BR 100/440 (3+1) TCG	54.0073	8TE	109 x 76.5 x 148mm	2 pcs.	1300g	28	
Class I, II Compact Single and Multi-pole SPD 35 and 50kA								
	SAFETEC B 35/150 TCG	54.0300	4TE	109 x 76.5 x 78mm	3 pcs.	410g	34	
	SAFETEC BR 35/150 TCG	54.0301	4TE	109 x 76.5 x 78mm	3 pcs.	415g	34	
	SAFETEC B 35/275 TCG	54.0302	4TE	109 x 76.5 x 78mm	3 pcs.	510g	34	
	SAFETEC BR 35/275 TCG	54.0303	4TE	109 x 76.5 x 78mm	3 pcs.	515g	34	
	SAFETEC B 35/440 TCG	54.0304	4TE	109 x 76.5 x 78mm	3 pcs.	700g	34	
	SAFETEC BR 35/440 TCG	54.0305	4TE	109 x 76.5 x 78mm	3 pcs.	705g	34	
	SAFETEC B 50/150 TCG	54.0306	4TE	109 x 76.5 x 78mm	3 pcs.	750g	35	
	SAFETEC BR 50/150 TCG	54.0307	4TE	109 x 76.5 x 78mm	3 pcs.	760g	35	
	SAFETEC B 50/275 TCG	54.0308	4TE	109 x 76.5 x 78mm	3 pcs.	970g	35	
	SAFETEC BR 50/275 TCG	54.0309	4TE	109 x 76.5 x 78mm	3 pcs.	980g	35	
	SAFETEC B 50/440 TCG	54.0310	4TE	109 x 76.5 x 78mm	3 pcs.	1100g	35	
	SAFETEC BR 50/440 TCG	54.0311	4TE	109 x 76.5 x 78mm	3 pcs.	1110g	35	
Class I, II Compact Single and Multi-pole SPD 12.5kA per pole								
	PROTEC B2N 12.5/150	507.501	1TE	108 x 74 x 24mm	12 pcs.	124g	38	
	PROTEC B2N 12.5/275	507.503	1TE	108 x 74 x 24mm	12 pcs.	150g	38	
	PROTEC B2N 12.5/320	507.505	1TE	108 x 74 x 24mm	12 pcs.	150g	38	
	PROTEC B2N 12.5/385	507.535	1TE	108 x 74 x 24mm	12 pcs.	143g	38	
	PROTEC B2N 12.5/440	507.507	1TE	108 x 74 x 24mm	12 pcs.	146g	38	
	PROTEC B2NR 12.5/150	507.509	1TE	108 x 74 x 24mm	12 pcs.	129g	38	
	PROTEC B2NR 12.5/275	507.511	1TE	108 x 74 x 24mm	12 pcs.	155g	38	
	PROTEC B2NR 12.5/320	507.513	1TE	108 x 74 x 24mm	12 pcs.	155g	38	
	PROTEC B2NR 12.5/385	507.537	1TE	108 x 74 x 24mm	12 pcs.	148g	38	
	PROTEC B2NR 12.5/440	507.515	1TE	108 x 74 x 24mm	12 pcs.	151g	38	
	PROTUBE B2N 50	507.572	1TE	109 x 76.5 x 24mm	7 pcs.	238g	39	
	PROBLOC BS 25/150 (2+0)	504.405	2TE	109 x 76.5 x 41.5mm	7 pcs.	198g	41	
	PROBLOC BS 25/275 (2+0)	504.406	2TE	109 x 76.5 x 41.5mm	7 pcs.	251g	41	
	PROBLOC BS 25/320 (2+0)	504.407	2TE	109 x 76.5 x 41.5mm	7 pcs.	251g	41	
	PROBLOC BS 25/385 (2+0)	504.408	2TE	109 x 76.5 x 41.5mm	7 pcs.	267g	41	
	PROBLOC BS 25/440 (2+0)	504.409	2TE	109 x 76.5 x 41.5mm	7 pcs.	283g	41	
	PROBLOC BSR 25/150 (2+0)	504.420	2TE	109 x 76.5 x 41.5mm	7 pcs.	203g	41	
	PROBLOC BSR 25/275 (2+0)	504.421	2TE	109 x 76.5 x 41.5mm	7 pcs.	256g	41	
	PROBLOC BSR 25/320 (2+0)	504.422	2TE	109 x 76.5 x 41.5mm	7 pcs.	256g	41	
	PROBLOC BSR 25/385 (2+0)	504.423	2TE	109 x 76.5 x 41.5mm	7 pcs.	272g	41	
	PROBLOC BSR 25/440 (2+0)	504.424	2TE	109 x 76.5 x 41.5mm	7 pcs.	288g	41	
		PROBLOC BS 37.5/150 (3+0)	504.049	3TE	109 x 76.5 x 60mm	5 pcs.	300g	42
		PROBLOC BS 37.5/275 (3+0)	504.051	3TE	109 x 76.5 x 60mm	5 pcs.	382g	42
PROBLOC BS 37.5/320 (3+0)		504.053	3TE	109 x 76.5 x 60mm	5 pcs.	382g	42	
PROBLOC BS 37.5/385 (3+0)		504.267	3TE	109 x 76.5 x 60mm	5 pcs.	394g	42	
PROBLOC BS 37.5/440 (3+0)		504.055	3TE	109 x 76.5 x 60mm	5 pcs.	432g	42	
PROBLOC BSR 37.5/150 (3+0)		504.057	3TE	109 x 76.5 x 60mm	5 pcs.	305g	42	
PROBLOC BSR 37.5/275 (3+0)		504.059	3TE	109 x 76.5 x 60mm	5 pcs.	387g	42	
PROBLOC BSR 37.5/320 (3+0)		504.061	3TE	109 x 76.5 x 60mm	5 pcs.	387g	42	
PROBLOC BSR 37.5/385 (3+0)		504.269	3TE	109 x 76.5 x 60mm	5 pcs.	399g	42	
PROBLOC BSR 37.5/440 (3+0)		504.063	3TE	109 x 76.5 x 60mm	5 pcs.	437g	42	
	PROBLOC BS 50/150 (4+0)	504.065	4TE	109 x 76.5 x 78mm	3 pcs.	366g	43	
	PROBLOC BS 50/275 (4+0)	504.067	4TE	109 x 76.5 x 78mm	3 pcs.	462g	43	
	PROBLOC BS 50/320 (4+0)	504.069	4TE	109 x 76.5 x 78mm	3 pcs.	462g	43	
	PROBLOC BS 50/385 (4+0)	504.271	4TE	109 x 76.5 x 78mm	3 pcs.	494g	43	
	PROBLOC BS 50/440 (4+0)	504.071	4TE	109 x 76.5 x 78mm	3 pcs.	526g	43	
	PROBLOC BSR 50/150 (4+0)	504.073	4TE	109 x 76.5 x 78mm	3 pcs.	371g	43	
	PROBLOC BSR 50/275 (4+0)	504.075	4TE	109 x 76.5 x 78mm	3 pcs.	467g	43	
	PROBLOC BSR 50/320 (4+0)	504.077	4TE	109 x 76.5 x 78mm	3 pcs.	467g	43	
	PROBLOC BSR 50/385 (4+0)	504.273	4TE	109 x 76.5 x 78mm	3 pcs.	499g	43	
	PROBLOC BSR 50/440 (4+0)	504.079	4TE	109 x 76.5 x 78mm	3 pcs.	531g	43	
	PROBLOC BS 25/150 (1+1)	504.410	2TE	109 x 76.5 x 41.5mm	7 pcs.	192g	45	
	PROBLOC BS 25/275 (1+1)	504.411	2TE	109 x 76.5 x 41.5mm	7 pcs.	245g	45	
	PROBLOC BS 25/320 (1+1)	504.412	2TE	109 x 76.5 x 41.5mm	7 pcs.	245g	45	
	PROBLOC BS 25/385 (1+1)	504.413	2TE	109 x 76.5 x 41.5mm	7 pcs.	261g	45	
	PROBLOC BS 25/440 (1+1)	504.414	2TE	109 x 76.5 x 41.5mm	7 pcs.	577g	45	

Product Index

Product name	Ordering code	Dimensions DIN 43880	Packaging dimensions (single unit)	Minimum packaging quantity	Weight	Page	
	PROBLOC BS 50/150 (3+1)	504.480	4TE	109 x 76.5 x 78mm	3 pcs.	442g	46
	PROBLOC BS 50/275 (3+1)	504.481	4TE	109 x 76.5 x 78mm	3 pcs.	538g	46
	PROBLOC BS 50/320 (3+1)	504.482	4TE	109 x 76.5 x 78mm	3 pcs.	538g	46
	PROBLOC BS 50/385 (3+1)	504.483	4TE	109 x 76.5 x 78mm	3 pcs.	548g	46
	PROBLOC BS 50/440 (3+1)	504.484	4TE	109 x 76.5 x 78mm	3 pcs.	577g	46
	PROBLOC BSR 50/150 (3+1)	504.485	4TE	109 x 76.5 x 78mm	3 pcs.	447g	46
	PROBLOC BSR 50/275 (3+1)	504.486	4TE	109 x 76.5 x 78mm	3 pcs.	543g	46
	PROBLOC BSR 50/320 (3+1)	504.487	4TE	109 x 76.5 x 78mm	3 pcs.	543g	46
	PROBLOC BSR 50/385 (3+1)	504.488	4TE	109 x 76.5 x 78mm	3 pcs.	553g	46
	PROBLOC BSR 50/440 (3+1)	504.489	4TE	109 x 76.5 x 78mm	3 pcs.	582g	46
Class I, II Compact Single and Multi-pole SPD 25kA per pole							
	PROTEC BS 25/150	502.326	2TE	109 x 76.5 x 41.5mm	7 pcs.	200g	52
	PROTEC BS 25/275	502.327	2TE	109 x 76.5 x 41.5mm	7 pcs.	252g	52
	PROTEC BS 25/320	502.328	2TE	109 x 76.5 x 41.5mm	7 pcs.	252g	52
	PROTEC BS 25/385	502.329	2TE	109 x 76.5 x 41.5mm	7 pcs.	268g	52
	PROTEC BS 25/440	502.330	2TE	109 x 76.5 x 41.5mm	7 pcs.	285g	52
	PROTEC BSR 25/150	502.331	2TE	109 x 76.5 x 41.5mm	7 pcs.	205g	52
	PROTEC BSR 25/275	502.332	2TE	109 x 76.5 x 41.5mm	7 pcs.	257g	52
	PROTEC BSR 25/320	502.333	2TE	109 x 76.5 x 41.5mm	7 pcs.	257g	52
	PROTEC BSR 25/385	502.334	2TE	109 x 76.5 x 41.5mm	7 pcs.	273g	52
	PROTEC BSR 25/440	502.335	2TE	109 x 76.5 x 41.5mm	7 pcs.	289g	52
	PROTUBE BS 100	5030.44	2TE	109 x 76.5 x 41.5mm	7 pcs.	238g	53
	PROTUBE BS 50	5030.42	2TE	109 x 76.5 x 41.5mm	7 pcs.	178g	53
	PROBLOC BS 50/150 (2+0)	504.435	2TE	109 x 76.5 x 41.5mm	7 pcs.	266g	55
	PROBLOC BS 50/275 (2+0)	504.436	2TE	109 x 76.5 x 41.5mm	7 pcs.	374g	55
	PROBLOC BS 50/320 (2+0)	504.437	2TE	109 x 76.5 x 41.5mm	7 pcs.	374g	55
	PROBLOC BS 50/385 (2+0)	504.438	4TE	109 x 76.5 x 78mm	3 pcs.	438g	55
	PROBLOC BS 50/440 (2+0)	504.439	4TE	109 x 76.5 x 78mm	3 pcs.	458g	55
	PROBLOC BSR 50/150 (2+0)	504.445	2TE	109 x 76.5 x 41.5mm	7 pcs.	271g	55
	PROBLOC BSR 50/275 (2+0)	504.446	2TE	109 x 76.5 x 41.5mm	7 pcs.	379g	55
	PROBLOC BSR 50/320 (2+0)	504.447	2TE	109 x 76.5 x 41.5mm	7 pcs.	379g	55
	PROBLOC BSR 50/385 (2+0)	504.448	4TE	109 x 76.5 x 78mm	3 pcs.	443g	55
	PROBLOC BSR 50/440 (2+0)	504.449	4TE	109 x 76.5 x 78mm	3 pcs.	463g	55
	PROBLOC BS 75/150 (3+0)	504.518	3TE	109 x 76.5 x 60mm	5 pcs.	400g	56
	PROBLOC BS 75/275 (3+0)	504.519	3TE	109 x 76.5 x 60mm	5 pcs.	570g	56
	PROBLOC BS 75/320 (3+0)	504.520	3TE	109 x 76.5 x 60mm	5 pcs.	570g	56
	PROBLOC BS 75/385 (3+0)	504.464	8TE	109 x 76.5 x 148mm	2 pcs.	726g	56
	PROBLOC BS 75/440 (3+0)	504.465	8TE	109 x 76.5 x 148mm	2 pcs.	792g	56
	PROBLOC BSR 75/150 (3+0)	504.521	3TE	109 x 76.5 x 60mm	5 pcs.	405g	56
	PROBLOC BSR 75/275 (3+0)	504.522	3TE	109 x 76.5 x 60mm	5 pcs.	575g	56
	PROBLOC BSR 75/320 (3+0)	504.523	3TE	109 x 76.5 x 60mm	5 pcs.	575g	56
	PROBLOC BSR 75/385 (3+0)	504.466	8TE	109 x 76.5 x 148mm	2 pcs.	731g	56
	PROBLOC BSR 75/440 (3+0)	504.467	8TE	109 x 76.5 x 148mm	2 pcs.	797g	56
	PROBLOC BS 100/150 (4+0)	504.524	4TE	109 x 76.5 x 78mm	3 pcs.	532g	57
	PROBLOC BS 100/275 (4+0)	504.525	4TE	109 x 76.5 x 78mm	3 pcs.	756g	57
	PROBLOC BS 100/320 (4+0)	504.526	4TE	109 x 76.5 x 78mm	3 pcs.	756g	57
	PROBLOC BS 100/385 (4+0)	504.468	8TE	109 x 76.5 x 148mm	2 pcs.	912g	57
	PROBLOC BS 100/440 (4+0)	504.469	8TE	109 x 76.5 x 148mm	2 pcs.	1000g	57
	PROBLOC BSR 100/150 (4+0)	504.527	4TE	109 x 76.5 x 78mm	3 pcs.	537g	57
	PROBLOC BSR 100/275 (4+0)	504.528	4TE	109 x 76.5 x 78mm	3 pcs.	761g	57
	PROBLOC BSR 100/320 (4+0)	504.529	4TE	109 x 76.5 x 78mm	3 pcs.	761g	57
	PROBLOC BSR 100/385 (4+0)	504.470	8TE	109 x 76.5 x 148mm	2 pcs.	917g	57
	PROBLOC BSR 100/440 (4+0)	504.471	8TE	109 x 76.5 x 148mm	2 pcs.	1005g	57
	PROBLOC BS 50/150 (1+1)	504.454	3TE	109 x 76.5 x 60mm	5 pcs.	308g	59
	PROBLOC BS 50/275 (1+1)	504.455	3TE	109 x 76.5 x 60mm	5 pcs.	364g	59
	PROBLOC BS 50/320 (1+1)	504.456	3TE	109 x 76.5 x 60mm	5 pcs.	364g	59
	PROBLOC BS 50/385 (1+1)	504.457	3TE	109 x 76.5 x 60mm	5 pcs.	386g	59
	PROBLOC BS 50/440 (1+1)	504.458	3TE	109 x 76.5 x 60mm	5 pcs.	408g	59
	PROBLOC BSR 50/150 (1+1)	504.459	3TE	109 x 76.5 x 60mm	5 pcs.	313g	59
	PROBLOC BSR 50/275 (1+1)	504.460	3TE	109 x 76.5 x 60mm	5 pcs.	369g	59
	PROBLOC BSR 50/320 (1+1)	504.461	3TE	109 x 76.5 x 60mm	5 pcs.	369g	59
	PROBLOC BSR 50/385 (1+1)	504.462	3TE	109 x 76.5 x 60mm	5 pcs.	391g	59
	PROBLOC BSR 50/440 (1+1)	504.463	3TE	109 x 76.5 x 60mm	5 pcs.	414g	59
	PROBLOC BS 100/150 (3+1)	504.530	5TE	109 x 76.5 x 96mm	3 pcs.	588g	60
	PROBLOC BS 100/275 (3+1)	504.531	5TE	109 x 76.5 x 96mm	3 pcs.	728g	60
	PROBLOC BS 100/320 (3+1)	504.532	5TE	109 x 76.5 x 96mm	3 pcs.	728g	60
	PROBLOC BS 100/385 (3+1)	504.472	8TE	109 x 76.5 x 148mm	2 pcs.	834g	60
	PROBLOC BS 100/440 (3+1)	504.473	8TE	109 x 76.5 x 148mm	2 pcs.	900g	60
	PROBLOC BSR 100/150 (3+1)	504.533	5TE	109 x 76.5 x 96mm	3 pcs.	573g	60
	PROBLOC BSR 100/275 (3+1)	504.534	5TE	109 x 76.5 x 96mm	3 pcs.	733g	60
	PROBLOC BSR 100/320 (3+1)	504.535	5TE	109 x 76.5 x 96mm	3 pcs.	733g	60
	PROBLOC BSR 100/385 (3+1)	504.474	8TE	109 x 76.5 x 148mm	2 pcs.	839g	60
	PROBLOC BSR 100/440 (3+1)	504.475	8TE	109 x 76.5 x 148mm	2 pcs.	905g	60

Product name	Ordering code	Dimensions DIN 43880	Packaging dimensions (single unit)	Minimum packaging quantity	Weight	Page		
Class I, II Compact Single and Multi-pole SPD 35kA and 50kA per pole								
	PROTEC BS 35/150	502.320	2TE	109 x 76.5 x 41.5mm	7 pcs.	254g	66	
	PROTEC BS 35/275	502.321	2TE	109 x 76.5 x 41.5mm	7 pcs.	336g	66	
	PROTEC BS 35/320	502.322	2TE	109 x 76.5 x 41.5mm	7 pcs.	336g	66	
	PROTEC BS 35/385	502.306	3TE	109 x 76.5 x 60mm	5 pcs.	385g	66	
	PROTEC BS 35/440	502.307	3TE	109 x 76.5 x 60mm	5 pcs.	415g	66	
	PROTEC BSR 35/150	502.323	2TE	109 x 76.5 x 41.5mm	7 pcs.	259g	66	
	PROTEC BSR 35/275	502.324	2TE	109 x 76.5 x 41.5mm	7 pcs.	341g	66	
	PROTEC BSR 35/320	502.325	2TE	109 x 76.5 x 41.5mm	7 pcs.	341g	66	
	PROTEC BSR 35/385	502.308	3TE	109 x 76.5 x 60mm	5 pcs.	390g	66	
	PROTEC BSR 35/440	502.309	3TE	109 x 76.5 x 60mm	5 pcs.	420g	66	
		PROTEC BS 50/150	502.314	2TE	109 x 76.5 x 41.5mm	7 pcs.	266g	67
		PROTEC BS 50/275	502.315	2TE	109 x 76.5 x 41.5mm	7 pcs.	374g	67
PROTEC BS 50/320		502.316	2TE	109 x 76.5 x 41.5mm	7 pcs.	374g	67	
PROTEC BS 50/385		502.296	4TE	109 x 76.5 x 78mm	3 pcs.	438g	67	
PROTEC BS 50/440		502.297	4TE	109 x 76.5 x 78mm	3 pcs.	458g	67	
PROTEC BSR 50/150		502.317	2TE	109 x 76.5 x 41.5mm	7 pcs.	271g	67	
PROTEC BSR 50/275		502.318	2TE	109 x 76.5 x 41.5mm	7 pcs.	379g	67	
PROTEC BSR 50/320		502.319	2TE	109 x 76.5 x 41.5mm	7 pcs.	379g	67	
PROTEC BSR 50/385		502.298	4TE	109 x 76.5 x 78mm	3 pcs.	443g	67	
PROTEC BSR 50/440		502.299	4TE	109 x 76.5 x 78mm	3 pcs.	463g	67	
		PROBLOC BS 100/150 (1+1)	504.512	4TE	109 x 76.5 x 78mm	3 pcs.	430g	69
		PROBLOC BS 100/275 (1+1)	504.513	4TE	109 x 76.5 x 78mm	3 pcs.	540g	69
	PROBLOC BS 100/320 (1+1)	504.514	4TE	109 x 76.5 x 78mm	3 pcs.	540g	69	
	PROBLOC BS 100/385 (1+1)	504.396	8TE	109 x 76.5 x 148mm	2 pcs.	654g	69	
	PROBLOC BS 100/440 (1+1)	504.397	8TE	109 x 76.5 x 148mm	2 pcs.	698g	69	
	PROBLOC BSR 100/150 (1+1)	504.515	4TE	109 x 76.5 x 78mm	3 pcs.	435g	69	
	PROBLOC BSR 100/275 (1+1)	504.516	4TE	109 x 76.5 x 78mm	3 pcs.	545g	69	
	PROBLOC BSR 100/320 (1+1)	504.517	4TE	109 x 76.5 x 78mm	3 pcs.	545g	69	
	PROBLOC BSR 100/385 (1+1)	504.398	8TE	109 x 76.5 x 148mm	2 pcs.	559g	69	
	PROBLOC BSR 100/440 (1+1)	504.399	8TE	109 x 76.5 x 148mm	2 pcs.	703g	69	
Class I, II Modular Single and Multi-pole SPD 12.5kA per pole								
	PROTEC B2S 12.5/150	506.017	1TE	109 x 74 x 24mm	12 pcs.	124g	72	
	PROTEC B2S 12.5/275	506.018	1TE	109 x 74 x 24mm	12 pcs.	150g	72	
	PROTEC B2S 12.5/320	506.019	1TE	109 x 74 x 24mm	12 pcs.	150g	72	
	PROTEC B2S 12.5/385	506.020	1TE	109 x 74 x 24mm	12 pcs.	143g	72	
	PROTEC B2S 12.5/440	506.021	1TE	109 x 74 x 24mm	12 pcs.	146g	72	
	PROTEC B2SR 12.5/150	506.022	1TE	109 x 74 x 24mm	12 pcs.	129g	72	
	PROTEC B2SR 12.5/275	506.023	1TE	109 x 74 x 24mm	12 pcs.	155g	72	
	PROTEC B2SR 12.5/320	506.024	1TE	109 x 74 x 24mm	12 pcs.	155g	72	
	PROTEC B2SR 12.5/385	506.025	1TE	109 x 74 x 24mm	12 pcs.	148g	72	
	PROTEC B2SR 12.5/440	506.026	1TE	109 x 74 x 24mm	12 pcs.	151g	72	
		PROTEC B2S 25/150 (2+0)	506.027	2TE	109 x 76.5 x 41.5mm	7 pcs.	198g	73
		PROTEC B2S 25/275 (2+0)	506.028	2TE	109 x 76.5 x 41.5mm	7 pcs.	251g	73
PROTEC B2S 25/320 (2+0)		506.029	2TE	109 x 76.5 x 41.5mm	7 pcs.	251g	73	
PROTEC B2S 25/385 (2+0)		506.030	2TE	109 x 76.5 x 41.5mm	7 pcs.	267g	73	
PROTEC B2S 25/440 (2+0)		506.031	2TE	109 x 76.5 x 41.5mm	7 pcs.	283g	73	
PROTEC B2SR 25/150 (2+0)		506.032	2TE	109 x 76.5 x 41.5mm	7 pcs.	203g	73	
PROTEC B2SR 25/275 (2+0)		506.033	2TE	109 x 76.5 x 41.5mm	7 pcs.	256g	73	
PROTEC B2SR 25/320 (2+0)		506.034	2TE	109 x 76.5 x 41.5mm	7 pcs.	256g	73	
PROTEC B2SR 25/385 (2+0)		506.035	2TE	109 x 76.5 x 41.5mm	7 pcs.	272g	73	
PROTEC B2SR 25/440 (2+0)		506.036	2TE	109 x 76.5 x 41.5mm	7 pcs.	288g	73	
	PROTEC B2S 37.5/150 (3+0)	506.047	3TE	109 x 76.5 x 60mm	5 pcs.	300g	73	
	PROTEC B2S 37.5/275 (3+0)	506.048	3TE	109 x 76.5 x 60mm	5 pcs.	382g	73	
	PROTEC B2S 37.5/320 (3+0)	506.049	3TE	109 x 76.5 x 60mm	5 pcs.	382g	73	
	PROTEC B2S 37.5/385 (3+0)	506.050	3TE	109 x 76.5 x 60mm	5 pcs.	394g	73	
	PROTEC B2S 37.5/440 (3+0)	506.051	3TE	109 x 76.5 x 60mm	5 pcs.	432g	73	
	PROTEC B2SR 37.5/150 (3+0)	506.052	3TE	109 x 76.5 x 60mm	5 pcs.	305g	73	
	PROTEC B2SR 37.5/275 (3+0)	506.053	3TE	109 x 76.5 x 60mm	5 pcs.	387g	73	
	PROTEC B2SR 37.5/320 (3+0)	506.054	3TE	109 x 76.5 x 60mm	5 pcs.	387g	73	
	PROTEC B2SR 37.5/385 (3+0)	506.055	3TE	109 x 76.5 x 60mm	5 pcs.	399g	73	
	PROTEC B2SR 37.5/440 (3+0)	506.056	3TE	109 x 76.5 x 60mm	5 pcs.	437g	73	
	PROTEC B2S 50/150 (4+0)	506.057	4TE	109 x 76.5 x 78mm	3 pcs.	366g	73	
	PROTEC B2S 50/275 (4+0)	506.058	4TE	109 x 76.5 x 78mm	3 pcs.	462g	73	
	PROTEC B2S 50/320 (4+0)	506.059	4TE	109 x 76.5 x 78mm	3 pcs.	462g	73	
	PROTEC B2S 50/385 (4+0)	506.060	4TE	109 x 76.5 x 78mm	3 pcs.	494g	73	
	PROTEC B2S 50/440 (4+0)	506.061	4TE	109 x 76.5 x 78mm	3 pcs.	526g	73	
	PROTEC B2SR 50/150 (4+0)	506.062	4TE	109 x 76.5 x 78mm	3 pcs.	371g	73	
	PROTEC B2SR 50/275 (4+0)	506.063	4TE	109 x 76.5 x 78mm	3 pcs.	467g	73	
	PROTEC B2SR 50/320 (4+0)	506.064	4TE	109 x 76.5 x 78mm	3 pcs.	467g	73	
	PROTEC B2SR 50/385 (4+0)	506.065	4TE	109 x 76.5 x 78mm	3 pcs.	499g	73	
	PROTEC B2SR 50/440 (4+0)	506.066	4TE	109 x 76.5 x 78mm	3 pcs.	531g	73	

Product name	Ordering code	Dimensions DIN 43880	Packaging dimensions (single unit)	Minimum packaging quantity	Weight	Page	
	PROTEC B2S 25/150 (1+1)	506.037	2TE	109 x 76.5 x 41.5mm	7 pcs.	270g	75
	PROTEC B2S 25/275 (1+1)	506.038	2TE	109 x 76.5 x 41.5mm	7 pcs.	310g	75
	PROTEC B2S 25/320 (1+1)	506.039	2TE	109 x 76.5 x 41.5mm	7 pcs.	342g	75
	PROTEC B2S 25/385 (1+1)	506.040	2TE	109 x 76.5 x 41.5mm	7 pcs.	366g	75
	PROTEC B2S 25/440 (1+1)	506.041	2TE	109 x 76.5 x 41.5mm	7 pcs.	370g	75
	PROTEC B2SR 25/150 (1+1)	506.042	2TE	109 x 76.5 x 41.5mm	7 pcs.	275g	75
	PROTEC B2SR 25/275 (1+1)	506.043	2TE	109 x 76.5 x 41.5mm	7 pcs.	315g	75
	PROTEC B2SR 25/320 (1+1)	506.044	2TE	109 x 76.5 x 41.5mm	7 pcs.	347g	75
	PROTEC B2SR 25/385 (1+1)	506.045	2TE	109 x 76.5 x 41.5mm	7 pcs.	371g	75
	PROTEC B2SR 25/440 (1+1)	506.046	2TE	109 x 76.5 x 41.5mm	7 pcs.	375g	75
	PROTEC B2S 50/150 (3+1)	506.067	4TE	109 x 76.5 x 78mm	3 pcs.	498g	75
	PROTEC B2S 50/275 (3+1)	506.068	4TE	109 x 76.5 x 78mm	3 pcs.	578g	75
	PROTEC B2S 50/320 (3+1)	506.069	4TE	109 x 76.5 x 78mm	3 pcs.	642g	75
	PROTEC B2S 50/385 (3+1)	506.070	4TE	109 x 76.5 x 78mm	3 pcs.	690g	75
	PROTEC B2S 50/440 (3+1)	506.071	4TE	109 x 76.5 x 78mm	3 pcs.	698g	75
	PROTEC B2SR 50/150 (3+1)	506.072	4TE	109 x 76.5 x 78mm	3 pcs.	503g	75
	PROTEC B2SR 50/275 (3+1)	506.073	4TE	109 x 76.5 x 78mm	3 pcs.	583g	75
	PROTEC B2SR 50/320 (3+1)	506.074	4TE	109 x 76.5 x 78mm	3 pcs.	647g	75
	PROTEC B2SR 50/385 (3+1)	506.075	4TE	109 x 76.5 x 78mm	3 pcs.	695g	75
	PROTEC B2SR 50/440 (3+1)	506.076	4TE	109 x 76.5 x 78mm	3 pcs.	703g	75
Module PROTEC B2S 12.5/150	506.001		219 x 62 x 47mm	12 pcs.	78g	72	
Module PROTEC B2S 12.5/275	506.002		219 x 62 x 47mm	12 pcs.	88g	72	
Module PROTEC B2S 12.5/320	506.003		219 x 62 x 47mm	12 pcs.	102g	72	
Module PROTEC B2S 12.5/385	506.004		219 x 62 x 47mm	12 pcs.	116g	72	
Module PROTEC B2S 12.5/440	506.005		219 x 62 x 47mm	12 pcs.	128g	72	
Module PROTUBE B2S 50/255	506.006		219 x 62 x 47mm	12 pcs.	70g	75	
Class II Modular Single and Multi-pole SPD up to 40kA per pole							
	SAFETEC C 20/75	516.612	1TE	108 x 74 x 24mm	12 pcs.	125g	80
	SAFETEC C 40/150	516.001	1TE	108 x 74 x 24mm	12 pcs.	140g	80
	SAFETEC C 40/275	516.003	1TE	108 x 74 x 24mm	12 pcs.	140g	80
	SAFETEC C 40/385	516.614	1TE	108 x 74 x 24mm	12 pcs.	148g	80
	SAFETEC C 40/440	516.005	1TE	108 x 74 x 24mm	12 pcs.	150g	80
	SAFETEC C 25/750	516.616	1TE	108 x 74 x 24mm	12 pcs.	156g	80
	SAFETEC CR 20/75	516.613	1TE	108 x 74 x 24mm	12 pcs.	130g	80
	SAFETEC CR 40/150	516.002	1TE	108 x 74 x 24mm	12 pcs.	148g	80
	SAFETEC CR 40/275	516.004	1TE	108 x 74 x 24mm	12 pcs.	148g	80
	SAFETEC CR 40/385	516.615	1TE	108 x 74 x 24mm	12 pcs.	156g	80
	SAFETEC CR 40/440	516.006	1TE	108 x 74 x 24mm	12 pcs.	158g	80
	SAFETEC CR 25/750	516.617	1TE	108 x 74 x 24mm	12 pcs.	164g	80
	Module SAFETEC C(R) 20/75	516.648		219 x 62 x 47mm	12 pcs.	58g	80
Module SAFETEC C(R) 40/150	516.037		219 x 62 x 47mm	12 pcs.	62g	80	
Module SAFETEC C(R) 40/275	516.038		219 x 62 x 47mm	12 pcs.	66g	80	
Module SAFETEC C(R) 40/385	516.649		219 x 62 x 47mm	12 pcs.	72g	80	
Module SAFETEC C(R) 40/440	516.039		219 x 62 x 47mm	12 pcs.	74g	80	
Module SAFETEC C(R) 25/750	516.650		219 x 62 x 47mm	12 pcs.	78g	80	
SAFETUBE C40/255	516.417	1TE	108 x 74 x 24mm	12 pcs.	118g	81	
Module SAFETUBE C 40/255	516.115		219 x 62 x 47mm	12 pcs.	34g	81	
	SAFETEC C 40/75 (2+0)	516.618	2TE	109 x 76.5 x 41.5mm	7 pcs.	250g	83
	SAFETEC C 80/150 (2+0)	516.007	2TE	109 x 76.5 x 41.5mm	7 pcs.	280g	83
	SAFETEC C 80/275 (2+0)	516.009	2TE	109 x 76.5 x 41.5mm	7 pcs.	281g	83
	SAFETEC C 80/385 (2+0)	516.620	2TE	109 x 76.5 x 41.5mm	7 pcs.	284g	83
	SAFETEC C 80/440 (2+0)	516.011	2TE	109 x 76.5 x 41.5mm	7 pcs.	286g	83
	SAFETEC C 50/750 (2+0)	516.622	2TE	109 x 76.5 x 41.5mm	7 pcs.	288g	83
	SAFETEC CR 40/75 (2+0)	516.619	2TE	109 x 76.5 x 41.5mm	7 pcs.	260g	83
	SAFETEC CR 80/150 (2+0)	516.008	2TE	109 x 76.5 x 41.5mm	7 pcs.	288g	83
	SAFETEC CR 80/275 (2+0)	516.010	2TE	109 x 76.5 x 41.5mm	7 pcs.	289g	83
	SAFETEC CR 80/385 (2+0)	516.621	2TE	109 x 76.5 x 41.5mm	7 pcs.	292g	83
	SAFETEC CR 80/440 (2+0)	516.012	2TE	109 x 76.5 x 41.5mm	7 pcs.	294g	83
	SAFETEC CR 50/750 (2+0)	516.623	2TE	109 x 76.5 x 41.5mm	7 pcs.	296g	83
	SAFETEC C 60/75 (3+0)	516.630	3TE	109 x 76.5 x 60mm	5 pcs.	375g	83
	SAFETEC C 120/150 (3+0)	516.019	3TE	109 x 76.5 x 60mm	5 pcs.	420g	83
	SAFETEC C 120/275 (3+0)	516.021	3TE	109 x 76.5 x 60mm	5 pcs.	422g	83
SAFETEC C 120/385 (3+0)	516.632	3TE	109 x 76.5 x 60mm	5 pcs.	448g	83	
SAFETEC C 120/440 (3+0)	516.023	3TE	109 x 76.5 x 60mm	5 pcs.	450g	83	
SAFETEC C 75/750 (3+0)	516.634	3TE	109 x 76.5 x 60mm	5 pcs.	468g	83	
SAFETEC CR 60/75 (3+0)	516.631	3TE	109 x 76.5 x 60mm	5 pcs.	390g	83	
SAFETEC CR 120/150 (3+0)	516.020	3TE	109 x 76.5 x 60mm	5 pcs.	428g	83	
SAFETEC CR 120/275 (3+0)	516.022	3TE	109 x 76.5 x 60mm	5 pcs.	430g	83	
SAFETEC CR 120/385 (3+0)	516.633	3TE	109 x 76.5 x 60mm	5 pcs.	456g	83	
SAFETEC CR 120/440 (3+0)	516.024	3TE	109 x 76.5 x 60mm	5 pcs.	458g	83	
SAFETEC CR 75/750 (3+0)	516.635	3TE	109 x 76.5 x 60mm	5 pcs.	476g	83	

Product name	Ordering code	Dimensions DIN 43880	Packaging dimensions (single unit)	Minimum packaging quantity	Weight	Page	
	SAFETEC C 80/75 (4+0)	516.636	4TE	109 x 76.5 x 78mm	3 pcs	500g	83
	SAFETEC C 160/150 (4+0)	516.025	4TE	109 x 76.5 x 78mm	3 pcs	560g	83
	SAFETEC C 160/275 (4+0)	516.027	4TE	109 x 76.5 x 78mm	3 pcs	562g	83
	SAFETEC C 160/385 (4+0)	516.638	4TE	109 x 76.5 x 78mm	3 pcs	595g	83
	SAFETEC C 160/440 (4+0)	516.029	4TE	109 x 76.5 x 78mm	3 pcs	598g	83
	SAFETEC C 100/750 (4+0)	516.640	4TE	109 x 76.5 x 78mm	3 pcs	602g	83
	SAFETEC CR 80/75 (4+0)	516.637	4TE	109 x 76.5 x 78mm	3 pcs	520g	83
	SAFETEC CR 160/150 (4+0)	516.026	4TE	109 x 76.5 x 78mm	3 pcs	568g	83
	SAFETEC CR 160/275 (4+0)	516.028	4TE	109 x 76.5 x 78mm	3 pcs	570g	83
	SAFETEC CR 160/385 (4+0)	516.639	4TE	109 x 76.5 x 78mm	3 pcs	603g	83
	SAFETEC CR 160/440 (4+0)	516.030	4TE	109 x 76.5 x 78mm	3 pcs	606g	83
	SAFETEC CR 100/750 (4+0)	516.641	4TE	109 x 76.5 x 78mm	3 pcs	610g	83
	SAFETEC C 40/75 (1+1)	516.624	2TE	109 x 76.5 x 78mm	7 pcs.	253g	85
	SAFETEC C 80/150 (1+1)	516.013	2TE	109 x 76.5 x 78mm	7 pcs.	258g	85
	SAFETEC C 80/275 (1+1)	516.015	2TE	109 x 76.5 x 78mm	7 pcs.	258g	85
	SAFETEC C 80/385 (1+1)	516.626	2TE	109 x 76.5 x 78mm	7 pcs.	265g	85
	SAFETEC C 80/440 (1+1)	516.017	2TE	109 x 76.5 x 78mm	7 pcs.	268g	85
	SAFETEC C 50/750 (1+1)	516.628	2TE	109 x 76.5 x 78mm	7 pcs.	271g	85
	SAFETEC CR 40/75 (1+1)	516.625	2TE	109 x 76.5 x 78mm	7 pcs.	261g	85
	SAFETEC CR 80/150 (1+1)	516.014	2TE	109 x 76.5 x 78mm	7 pcs.	266g	85
	SAFETEC CR 80/275 (1+1)	516.016	2TE	109 x 76.5 x 78mm	7 pcs.	266g	85
	SAFETEC CR 80/385 (1+1)	516.627	2TE	109 x 76.5 x 78mm	7 pcs.	274g	85
	SAFETEC CR 80/440 (1+1)	516.018	2TE	109 x 76.5 x 78mm	7 pcs.	276g	85
	SAFETEC CR 50/750 (1+1)	516.629	2TE	109 x 76.5 x 78mm	7 pcs.	279g	85
	SAFETEC C 80/75 (3+1)	516.642	4TE	109 x 76.5 x 78mm	3 pcs.	533g	85
	SAFETEC C 160/150 (3+1)	516.031	4TE	109 x 76.5 x 78mm	3 pcs.	538g	85
	SAFETEC C 160/275 (3+1)	516.033	4TE	109 x 76.5 x 78mm	3 pcs.	540g	85
	SAFETEC C 160/385 (3+1)	516.644	4TE	109 x 76.5 x 78mm	3 pcs.	565g	85
	SAFETEC C 160/440 (3+1)	516.035	4TE	109 x 76.5 x 78mm	3 pcs.	568g	85
	SAFETEC C 100/750 (3+1)	516.646	4TE	109 x 76.5 x 78mm	3 pcs.	571g	85
	SAFETEC CR 80/75 (3+1)	516.643	4TE	109 x 76.5 x 78mm	3 pcs.	541g	85
	SAFETEC CR 160/150 (3+1)	516.032	4TE	109 x 76.5 x 78mm	3 pcs.	546g	85
	SAFETEC CR 160/275 (3+1)	516.034	4TE	109 x 76.5 x 78mm	3 pcs.	548g	85
	SAFETEC CR 160/385 (3+1)	516.645	4TE	109 x 76.5 x 78mm	3 pcs.	574g	85
	SAFETEC CR 160/440 (3+1)	516.036	4TE	109 x 76.5 x 78mm	3 pcs.	576g	85
	SAFETEC CR 100/750 (3+1)	516.647	4TE	109 x 76.5 x 78mm	3 pcs.	579g	85
Module SAFETEC C(R) 20/75	516.648		219 x 62 x 47mm	12 pcs.	58g	80	
Module SAFETEC C(R) 40/150	516.037		219 x 62 x 47mm	12 pcs.	62g	80	
Module SAFETEC C(R) 40/275	516.038		219 x 62 x 47mm	12 pcs.	66g	80	
Module SAFETEC C(R) 40/385	516.649		219 x 62 x 47mm	12 pcs.	72g	80	
Module SAFETEC C(R) 40/440	516.039		219 x 62 x 47mm	12 pcs.	74g	80	
Module SAFETEC C(R) 25/750	516.650		219 x 62 x 47mm	12 pcs.	78g	80	
Module SAFETUBE C 40/255	516.115		219 x 62 x 47mm	12 pcs.	34g	81	
Type 2 Modular Single and Multi-pole SPD							
	SAFETEC C 50/150 UL	516.058	1TE	219 x 62 x 47mm	12 pcs.	62g	90
	SAFETEC C 50/277 UL	516.060	1TE	219 x 62 x 47mm	12 pcs.	66g	90
	SAFETEC C 50/385 UL	516.062	1TE	219 x 62 x 47mm	12 pcs.	72g	90
	SAFETEC C 50/440 UL	516.064	1TE	219 x 62 x 47mm	12 pcs.	74g	90
	SAFETEC C 50/550 UL	516.066	1TE	219 x 62 x 47mm	12 pcs.	76g	90
	SAFETEC C 20/750 UL	516.068	1TE	219 x 62 x 47mm	12 pcs.	78g	90
	SAFETEC C 20/880 UL	516.586	1TE	219 x 62 x 47mm	12 pcs.	78g	90
	SAFETEC CR 50/150 UL	516.059	1TE	219 x 62 x 47mm	12 pcs.	62g	90
	SAFETEC CR 50/277 UL	516.061	1TE	219 x 62 x 47mm	12 pcs.	66g	90
	SAFETEC CR 50/385 UL	516.063	1TE	219 x 62 x 47mm	12 pcs.	72g	90
	SAFETEC CR 50/440 UL	516.065	1TE	219 x 62 x 47mm	12 pcs.	74g	90
	SAFETEC CR 50/550 UL	516.067	1TE	219 x 62 x 47mm	12 pcs.	76g	90
SAFETEC CR 25/750 UL	516.069	1TE	219 x 62 x 47mm	12 pcs.	78g	90	
SAFETEC CR 25/880 UL	516.587	1TE	219 x 62 x 47mm	12 pcs.	78g	90	
	SAFETEC C 100/150 (2+0) UL	516.070	2TE	109 x 76.5 x 41.5mm	7 pcs.	280g	91
	SAFETEC C 100/277 (2+0) UL	516.072	2TE	109 x 76.5 x 41.5mm	7 pcs.	281g	91
	SAFETEC C 100/385 (2+0) UL	516.074	2TE	109 x 76.5 x 41.5mm	7 pcs.	290g	91
	SAFETEC C 100/440 (2+0) UL	516.076	2TE	109 x 76.5 x 41.5mm	7 pcs.	299g	91
	SAFETEC C 40/750 (2+0) UL	516.080	2TE	109 x 76.5 x 41.5mm	7 pcs.	312g	91
	SAFETEC C 40/880 (2+0) UL	516.088	2TE	109 x 76.5 x 41.5mm	7 pcs.	312g	91
	SAFETEC CR 100/150 (2+0) UL	516.071	2TE	109 x 76.5 x 41.5mm	7 pcs.	288g	91
	SAFETEC CR 100/277 (2+0) UL	516.073	2TE	109 x 76.5 x 41.5mm	7 pcs.	289g	91
	SAFETEC CR 100/385 (2+0) UL	516.075	2TE	109 x 76.5 x 41.5mm	7 pcs.	298g	91
	SAFETEC CR 100/440 (2+0) UL	516.077	2TE	109 x 76.5 x 41.5mm	7 pcs.	307g	91
	SAFETEC CR 40/750 (2+0) UL	516.081	2TE	109 x 76.5 x 41.5mm	7 pcs.	320g	91
	SAFETEC CR 40/880 (2+0) UL	516.089	2TE	109 x 76.5 x 41.5mm	7 pcs.	320g	91
SAFETEC C 150/150 (3+0) UL	516.082	3TE	109 x 76.5 x 60mm	5 pcs.	420g	91	
SAFETEC C 150/277 (3+0) UL	516.084	3TE	109 x 76.5 x 60mm	5 pcs.	422g	91	
SAFETEC C 150/385 (3+0) UL	516.086	3TE	109 x 76.5 x 60mm	5 pcs.	435g	91	

Product name	Ordering code	Dimensions DIN 43880	Packaging dimensions (single unit)	Minimum packaging quantity	Weight	Page	
	SAFETEC C 150/440 (3+0) UL	516.088	3TE	109 x 76.5 x 60mm	5 pcs.	450g	91
	SAFETEC C 150/550 (3+0) UL	516.090	3TE	109 x 76.5 x 60mm	5 pcs.	459g	91
	SAFETEC C 60/750 (3+0) UL	516.091	3TE	109 x 76.5 x 60mm	5 pcs.	468g	91
	SAFETEC C 60/880 (3+0) UL	516.590	3TE	109 x 76.5 x 60mm	5 pcs.	468g	91
	SAFETEC CR 150/150 (3+0) UL	516.083	3TE	109 x 76.5 x 60mm	5 pcs.	428g	91
	SAFETEC CR 150/277 (3+0) UL	516.085	3TE	109 x 76.5 x 60mm	5 pcs.	430g	91
	SAFETEC CR 150/385 (3+0) UL	516.087	3TE	109 x 76.5 x 60mm	5 pcs.	443g	91
	SAFETEC CR 150/440 (3+0) UL	516.089	3TE	109 x 76.5 x 60mm	5 pcs.	458g	91
	SAFETEC CR 150/550 (3+0) UL	516.130	3TE	109 x 76.5 x 60mm	5 pcs.	467g	91
	SAFETEC CR 60/750 (3+0) UL	516.092	3TE	109 x 76.5 x 60mm	5 pcs.	476g	91
	SAFETEC CR 60/880 (3+0) UL	516.591	3TE	109 x 76.5 x 60mm	5 pcs.	476g	91
	SAFETEC C 200/150 (4+0) UL	516.093	4TE	109 x 76.5 x 78mm	3 pcs.	560g	91
	SAFETEC C 200/277 (4+0) UL	516.095	4TE	109 x 76.5 x 78mm	3 pcs.	562g	91
	SAFETEC C 200/385 (4+0) UL	516.097	4TE	109 x 76.5 x 78mm	3 pcs.	580g	91
	SAFETEC C 200/440 (4+0) UL	516.099	4TE	109 x 76.5 x 78mm	3 pcs.	598g	91
	SAFETEC C 80/750 (4+0) UL	516.103	4TE	109 x 76.5 x 78mm	3 pcs.	624g	91
	SAFETEC C 80/880 (4+0) UL	516.592	4TE	109 x 76.5 x 78mm	3 pcs.	624g	91
	SAFETEC CR 200/150 (4+0) UL	516.094	4TE	109 x 76.5 x 78mm	3 pcs.	568g	91
	SAFETEC CR 200/277 (4+0) UL	516.096	4TE	109 x 76.5 x 78mm	3 pcs.	570g	91
	SAFETEC CR 200/385 (4+0) UL	516.098	4TE	109 x 76.5 x 78mm	3 pcs.	588g	91
	SAFETEC CR 200/440 (4+0) UL	516.100	4TE	109 x 76.5 x 78mm	3 pcs.	606g	91
	SAFETEC CR 80/750 (4+0) UL	516.104	4TE	109 x 76.5 x 78mm	3 pcs.	632g	91
SAFETEC CR 80/880 (4+0) UL	516.593	4TE	109 x 76.5 x 78mm	3 pcs.	632g	91	
Module SAFETEC C(R) 50/150 UL	516.201		219 x 62 x 47mm	12 pcs.	62g	91	
Module SAFETEC C(R) 50/277 UL	516.202		219 x 62 x 47mm	12 pcs.	66g	91	
Module SAFETEC C(R) 50/385 UL	516.203		219 x 62 x 47mm	12 pcs.	72g	91	
Module SAFETEC C(R) 50/440 UL	516.204		219 x 62 x 47mm	12 pcs.	74g	91	
Module SAFETEC C(R) 50/550 UL	516.205		219 x 62 x 47mm	12 pcs.	76g	91	
Module SAFETEC C(R) 20/750 UL	516.206		219 x 62 x 47mm	12 pcs.	78g	91	
Module SAFETEC C(R) 20/880 UL	516.585		219 x 62 x 47mm	12 pcs.	78g	91	
Class II Modular Single and Multi-pole SPD 40kA per pole							
	PROTEC C 40/75	50.0001	1TE	108 x 74 x 24mm	12 pcs.	112g	96
	PROTEC C 40/150	50.0003	1TE	108 x 74 x 24mm	12 pcs.	122g	96
	PROTEC C 40/275	50.0005	1TE	108 x 74 x 24mm	12 pcs.	128g	96
	PROTEC C 40/320	50.0007	1TE	108 x 74 x 24mm	12 pcs.	128g	96
	PROTEC C 40/385	50.0171	1TE	108 x 74 x 24mm	12 pcs.	129g	96
	PROTEC C 40/440	50.0009	1TE	108 x 74 x 24mm	12 pcs.	130g	96
	PROTEC CR 40/75	50.0011	1TE	108 x 74 x 24mm	12 pcs.	117g	96
	PROTEC CR 40/150	50.0013	1TE	108 x 74 x 24mm	12 pcs.	127g	96
	PROTEC CR 40/275	50.0015	1TE	108 x 74 x 24mm	12 pcs.	133g	96
	PROTEC CR 40/320	50.0017	1TE	108 x 74 x 24mm	12 pcs.	133g	96
	PROTEC CR 40/385	50.0175	1TE	108 x 74 x 24mm	12 pcs.	134g	96
PROTEC CR 40/440	50.0019	1TE	108 x 74 x 24mm	12 pcs.	145g	96	
Module PROTEC C(R) 40/75	50.0216		219 x 62 x 47mm	12 pcs.	44g		
Module PROTEC C(R) 40/150	50.0217		219 x 62 x 47mm	12 pcs.	48g		
Module PROTEC C(R) 40/275	50.0219		219 x 62 x 47mm	12 pcs.	52g		
Module PROTEC C(R) 40/320	50.0220		219 x 62 x 47mm	12 pcs.	56g		
Module PROTEC C(R) 40/385	50.0221		219 x 62 x 47mm	12 pcs.	58g		
Module PROTEC C(R) 40/440	50.0222		219 x 62 x 47mm	12 pcs.	60g		
	PROTUBE C40/255	50.3005	1TE	108 x 74 x 24mm	12 pcs.	118g	97
Module PROTUBE C 40/255	50.0234		219 x 62 x 47mm	12 pcs.	36g	97	
	PROTEC C 80/150 (2+0)	50.0073	2TE	109 x 76.5 x 41.5mm	7 pcs.	234g	99
	PROTEC C 80/275 (2+0)	50.0075	2TE	109 x 76.5 x 41.5mm	7 pcs.	244g	99
	PROTEC C 80/320 (2+0)	50.0077	2TE	109 x 76.5 x 41.5mm	7 pcs.	244g	99
	PROTEC C 80/385 (2+0)	50.0179	2TE	109 x 76.5 x 41.5mm	7 pcs.	245g	99
	PROTEC C 80/440 (2+0)	50.0079	2TE	109 x 76.5 x 41.5mm	7 pcs.	247g	99
	PROTEC CR 80/150 (2+0)	50.0081	2TE	109 x 76.5 x 41.5mm	7 pcs.	239g	99
	PROTEC CR 80/275 (2+0)	50.0083	2TE	109 x 76.5 x 41.5mm	7 pcs.	249g	99
	PROTEC CR 80/320 (2+0)	50.0085	2TE	109 x 76.5 x 41.5mm	7 pcs.	249g	99
	PROTEC CR 80/385 (2+0)	50.0183	2TE	109 x 76.5 x 41.5mm	7 pcs.	250g	99
	PROTEC CR 80/440 (2+0)	50.0087	2TE	109 x 76.5 x 41.5mm	7 pcs.	252g	99
		PROTEC C 120/150 (3+0)	50.0105	3TE	109 x 76.5 x 60mm	5 pcs.	330g
PROTEC C 120/275 (3+0)		50.0107	3TE	109 x 76.5 x 60mm	5 pcs.	352g	99
PROTEC C 120/320 (3+0)		50.0109	3TE	109 x 76.5 x 60mm	5 pcs.	352g	99
PROTEC C 120/385 (3+0)		50.0195	3TE	109 x 76.5 x 60mm	5 pcs.	354g	99
PROTEC C 120/440 (3+0)		50.0111	3TE	109 x 76.5 x 60mm	5 pcs.	356g	99
PROTEC CR 120/150 (3+0)		50.0113	3TE	109 x 76.5 x 60mm	5 pcs.	335g	99
PROTEC CR 120/275 (3+0)		50.0115	3TE	109 x 76.5 x 60mm	5 pcs.	357g	99
PROTEC CR 120/320 (3+0)		50.0117	3TE	109 x 76.5 x 60mm	5 pcs.	357g	99
PROTEC CR 120/385 (3+0)		50.0199	3TE	109 x 76.5 x 60mm	5 pcs.	359g	99
PROTEC CR 120/440 (3+0)		50.0119	3TE	109 x 76.5 x 60mm	5 pcs.	361g	99

Product name	Ordering code	Dimensions DIN 43880	Packaging dimensions (single unit)	Minimum packaging quantity	Weight	Page	
	PROTEC C 160/150 (4+0)	50.0121	4TE	109 x 76.5 x 78mm	3 pcs.	432g	99
	PROTEC C 160/275 (4+0)	50.0123	4TE	109 x 76.5 x 78mm	3 pcs.	456g	99
	PROTEC C 160/320 (4+0)	50.0125	4TE	109 x 76.5 x 78mm	3 pcs.	456g	99
	PROTEC C 160/385 (4+0)	50.0203	4TE	109 x 76.5 x 78mm	3 pcs.	460g	99
	PROTEC C 160/440 (4+0)	50.0127	4TE	109 x 76.5 x 78mm	3 pcs.	466g	99
	PROTEC CR 160/150 (4+0)	50.0129	4TE	109 x 76.5 x 78mm	3 pcs.	437g	99
	PROTEC CR 160/275 (4+0)	50.0131	4TE	109 x 76.5 x 78mm	3 pcs.	461g	99
	PROTEC CR 160/320 (4+0)	50.0133	4TE	109 x 76.5 x 78mm	3 pcs.	461g	99
	PROTEC CR 160/385 (4+0)	50.0207	4TE	109 x 76.5 x 78mm	3 pcs.	465g	99
	PROTEC CR 160/440 (4+0)	50.0135	4TE	109 x 76.5 x 78mm	3 pcs.	471g	99
Module PROTEC C(R) 40/75	50.0216		219 x 62 x 47mm	12 pcs.	44g	99	
Module PROTEC C(R) 40/150	50.0217		219 x 62 x 47mm	12 pcs.	48g	99	
Module PROTEC C(R) 40/275	50.0219		219 x 62 x 47mm	12 pcs.	52g	99	
Module PROTEC C(R) 40/320	50.0220		219 x 62 x 47mm	12 pcs.	56g	99	
Module PROTEC C(R) 40/385	50.0221		219 x 62 x 47mm	12 pcs.	58g	99	
Module PROTEC C(R) 40/440	50.0222		219 x 62 x 47mm	12 pcs.	60g	99	
	PROTEC C 80/150 (1+1)	50.0089	2TE	109 x 76.5 x 41.5mm	7 pcs.	221g	101
	PROTEC C 80/275 (1+1)	50.0091	2TE	109 x 76.5 x 41.5mm	7 pcs.	225g	101
	PROTEC C 80/320 (1+1)	50.0093	2TE	109 x 76.5 x 41.5mm	7 pcs.	225g	101
	PROTEC C 80/385 (1+1)	50.0187	2TE	109 x 76.5 x 41.5mm	7 pcs.	226g	101
	PROTEC C 80/440 (1+1)	50.0095	2TE	109 x 76.5 x 41.5mm	7 pcs.	227g	101
	PROTEC CR 80/150 (1+1)	50.0097	2TE	109 x 76.5 x 41.5mm	7 pcs.	226g	101
	PROTEC CR 80/275 (1+1)	50.0099	2TE	109 x 76.5 x 41.5mm	7 pcs.	230g	101
	PROTEC CR 80/320 (1+1)	50.0101	2TE	109 x 76.5 x 41.5mm	7 pcs.	230g	101
	PROTEC CR 80/385 (1+1)	50.0191	2TE	109 x 76.5 x 41.5mm	7 pcs.	231g	101
	PROTEC CR 80/440 (1+1)	50.0103	2TE	109 x 76.5 x 41.5mm	7 pcs.	232g	101
	PROTEC C 160/150 (3+1)	50.0137	4TE	109 x 76.5 x 78mm	3 pcs.	423g	101
	PROTEC C 160/275 (3+1)	50.0139	4TE	109 x 76.5 x 78mm	3 pcs.	441g	101
	PROTEC C 160/320 (3+1)	50.0141	4TE	109 x 76.5 x 78mm	3 pcs.	441g	101
	PROTEC C 160/385 (3+1)	50.0211	4TE	109 x 76.5 x 78mm	3 pcs.	445g	101
	PROTEC C 160/440 (3+1)	50.0143	4TE	109 x 76.5 x 78mm	3 pcs.	447g	101
	PROTEC CR 160/150 (3+1)	50.0145	4TE	109 x 76.5 x 78mm	3 pcs.	428g	101
	PROTEC CR 160/275 (3+1)	50.0147	4TE	109 x 76.5 x 78mm	3 pcs.	446g	101
	PROTEC CR 160/320 (3+1)	50.0149	4TE	109 x 76.5 x 78mm	3 pcs.	446g	101
	PROTEC CR 160/385 (3+1)	50.0215	4TE	109 x 76.5 x 78mm	3 pcs.	450g	101
	PROTEC CR 160/440 (3+1)	50.0151	4TE	109 x 76.5 x 78mm	3 pcs.	452g	101
Module PROTEC C(R) 40/75	50.0216		219 x 62 x 47mm	12 pcs.	44g	101	
Module PROTEC C(R) 40/150	50.0217		219 x 62 x 47mm	12 pcs.	48g	101	
Module PROTEC C(R) 40/275	50.0219		219 x 62 x 47mm	12 pcs.	52g	101	
Module PROTEC C(R) 40/320	50.0220		219 x 62 x 47mm	12 pcs.	56g	101	
Module PROTEC C(R) 40/385	50.0221		219 x 62 x 47mm	12 pcs.	58g	101	
Module PROTEC C(R) 40/440	50.0222		219 x 62 x 47mm	12 pcs.	60g	101	
Module PROTUBE C 40/255	50.0234		219 x 62 x 47mm	12 pcs.	36g	101	
Class II Modular Single up to 40kA							
	PROTEC C 20/150	50.0037	1TE	108 x 74 x 24mm	12 pcs.	119g	106
	PROTEC C 20/275	50.0039	1TE	108 x 74 x 24mm	12 pcs.	125g	106
	PROTEC C 20/320	50.0041	1TE	108 x 74 x 24mm	12 pcs.	125g	106
	PROTEC C 20/385	50.0315	1TE	108 x 74 x 24mm	12 pcs.	126g	106
	PROTEC C 20/440	50.0043	1TE	108 x 74 x 24mm	12 pcs.	127g	106
	PROTEC CR 20/150	50.0045	1TE	108 x 74 x 24mm	12 pcs.	124g	106
	PROTEC CR 20/275	50.0047	1TE	108 x 74 x 24mm	12 pcs.	130g	106
	PROTEC CR 20/320	50.0049	1TE	108 x 74 x 24mm	12 pcs.	140g	106
	PROTEC CR 20/385	50.0317	1TE	108 x 74 x 24mm	12 pcs.	131g	106
	PROTEC CR 20/440	50.0051	1TE	108 x 74 x 24mm	12 pcs.	132g	106
Module PROTEC C(R) 20/150	50.0479		219 x 62 x 47mm	12 pcs.	48g	106	
Module PROTEC C(R) 20/275	50.0480		219 x 62 x 47mm	12 pcs.	56g	106	
Module PROTEC C(R) 20/320	50.0481		219 x 62 x 47mm	12 pcs.	56g	106	
Module PROTEC C(R) 20/385	50.0482		219 x 62 x 47mm	12 pcs.	60g	106	
Module PROTEC C(R) 20/440	50.0483		219 x 62 x 47mm	12 pcs.	58g	106	
	PROTEC CN 20/150	507.253	1TE	108 x 74 x 24mm	12 pcs.	131g	107
	PROTEC CN 20/275	507.254	1TE	108 x 74 x 24mm	12 pcs.	109g	107
	PROTEC CN 20/320	507.255	1TE	108 x 74 x 24mm	12 pcs.	109g	107
	PROTEC CN 20/385	507.256	1TE	108 x 74 x 24mm	12 pcs.	136g	107
	PROTEC CN 20/440	507.257	1TE	108 x 74 x 24mm	12 pcs.	137g	107
	PROTEC CNR 20/150	507.258	1TE	108 x 74 x 24mm	12 pcs.	136g	107
	PROTEC CNR 20/275	507.259	1TE	108 x 74 x 24mm	12 pcs.	114g	107
	PROTEC CNR 20/320	507.260	1TE	108 x 74 x 24mm	12 pcs.	114g	107
	PROTEC CNR 20/385	507.261	1TE	108 x 74 x 24mm	12 pcs.	141g	107
	PROTEC CNR 20/440	507.262	1TE	108 x 74 x 24mm	12 pcs.	142g	107
PROTEC CN 40/75	507.001	1TE	108 x 74 x 24mm	12 pcs.	127g	108	
PROTEC CN 40/150	507.003	1TE	108 x 74 x 24mm	12 pcs.	134g	108	

Product name	Ordering code	Dimensions DIN 43880	Packaging dimensions (single unit)	Minimum packaging quantity	Weight	Page	
	PROTEC CN 40/275	507.005	1TE	108 x 74 x 24mm	12 pcs.	112g	108
	PROTEC CN 40/320	507.007	1TE	108 x 74 x 24mm	12 pcs.	112g	108
	PROTEC CN 40/385	507.021	1TE	108 x 74 x 24mm	12 pcs.	139g	108
	PROTEC CN 40/440	507.009	1TE	108 x 74 x 24mm	12 pcs.	140g	108
	PROTEC CNR 40/75	507.011	1TE	108 x 74 x 24mm	12 pcs.	132g	108
	PROTEC CNR 40/150	507.013	1TE	108 x 74 x 24mm	12 pcs.	139g	108
	PROTEC CNR 40/275	507.015	1TE	108 x 74 x 24mm	12 pcs.	117g	108
	PROTEC CNR 40/320	507.017	1TE	108 x 74 x 24mm	12 pcs.	117g	108
	PROTEC CNR 40/385	507.023	1TE	108 x 74 x 24mm	12 pcs.	144g	108
	PROTEC CNR 40/440	507.019	1TE	108 x 74 x 24mm	12 pcs.	145g	108
	PROTUBE CN 40/255	507.574	1TE	108 x 74 x 24mm	12 pcs.	122g	109
	PROTEC CG 20/150	50.0239	1TE	108 x 74 x 24mm	12 pcs.	112g	111
	PROTEC CG 20/275	50.0241	1TE	108 x 74 x 24mm	12 pcs.	128g	111
	PROTEC CG 20/385	50.0243	1TE	108 x 74 x 24mm	12 pcs.	130g	111
	PROTEC CGR 20/150	50.0245	1TE	108 x 74 x 24mm	12 pcs.	117g	111
	PROTEC CGR 20/275	50.0247	1TE	108 x 74 x 24mm	12 pcs.	133g	111
	PROTEC CGR 20/385	50.0249	1TE	108 x 74 x 24mm	12 pcs.	135g	111
	Module PROTEC CG(R) 20/150	50.0235		219 x 62 x 47mm	12 pcs.	40g	111
Module PROTEC CG(R) 20/275	50.0236		219 x 62 x 47mm	12 pcs.	56g	111	
Module PROTEC CG(R) 20/385	50.0237		219 x 62 x 47mm	12 pcs.	58g	111	
	PROTEC CG 40/150	50.0323	1TE	219 x 62 x 47mm	12 pcs.	112g	112
	PROTEC CG 40/275	50.0325	1TE	219 x 62 x 47mm	12 pcs.	130g	112
	PROTEC CG 40/385	50.0327	1TE	219 x 62 x 47mm	12 pcs.	132g	112
	PROTEC CGR 40/150	50.0329	1TE	219 x 62 x 47mm	12 pcs.	117g	112
	PROTEC CGR 40/275	50.0331	1TE	219 x 62 x 47mm	12 pcs.	135g	112
	PROTEC CGR 40/385	50.0333	1TE	219 x 62 x 47mm	12 pcs.	137g	112
	Module PROTEC CG(R) 40/150	50.0502		219 x 62 x 47mm	12 pcs.	40g	112
	Module PROTEC CG(R) 40/275	50.0503		219 x 62 x 47mm	12 pcs.	56g	112
	Module PROTEC CG(R) 40/385	50.0504		219 x 62 x 47mm	12 pcs.	58g	112
	Class II Modular and Multi-pole SPD up to 40kA per pole						
	PROTEC CMG 40/150 (2+0)	508.197	1TE	108 x 74 x 24mm	12 pcs.	130g	118
	PROTEC CMG 40/275 (2+0)	508.198	1TE	108 x 74 x 24mm	12 pcs.	146g	118
	PROTEC CMGR 40/150 (2+0)	508.199	1TE	108 x 74 x 24mm	12 pcs.	135g	118
	PROTEC CMGR 40/275 (2+0)	508.200	1TE	108 x 74 x 24mm	12 pcs.	151g	118
	Module PROTEC CMG(R) 40/150 (2+0)	508.201		219 x 62 x 47mm	12 pcs.	63g	118
Module PROTEC CMG(R) 40/275 (2+0)	508.202		219 x 62 x 47mm	12 pcs.	79g	118	
	PROTEC CM 80/150 (2+0)	508.001	1TE	108 x 74 x 24mm	12 pcs.	134g	119
	PROTEC CM 80/275 (2+0)	508.003	1TE	108 x 74 x 24mm	12 pcs.	144g	119
	PROTEC CM 80/320 (2+0)	508.005	1TE	108 x 74 x 24mm	12 pcs.	144g	119
	PROTEC CM 80/385 (2+0)	508.109	1TE	108 x 74 x 24mm	12 pcs.	150g	119
	PROTEC CM 80/440 (2+0)	508.007	1TE	108 x 74 x 24mm	12 pcs.	152g	119
	PROTEC CMR 80/150 (2+0)	508.009	1TE	108 x 74 x 24mm	12 pcs.	139g	119
	PROTEC CMR 80/275 (2+0)	508.011	1TE	108 x 74 x 24mm	12 pcs.	149g	119
	PROTEC CMR 80/320 (2+0)	508.013	1TE	108 x 74 x 24mm	12 pcs.	149g	119
	PROTEC CMR 80/385 (2+0)	508.111	1TE	108 x 74 x 24mm	12 pcs.	155g	119
	PROTEC CMR 80/440 (2+0)	508.015	1TE	108 x 74 x 24mm	12 pcs.	147g	119
	Module PROTEC CM(R) 80/150 (2+0)	508.174		219 x 62 x 47mm	12 pcs.	67g	119
	Module PROTEC CM(R) 80/275 (2+0)	508.164		219 x 62 x 47mm	12 pcs.	78g	119
	Module PROTEC CM(R) 80/320 (2+0)	508.175		219 x 62 x 47mm	12 pcs.	78g	119
	Module PROTEC CM(R) 80/385 (2+0)	508.146		219 x 62 x 47mm	12 pcs.	83g	119
	Module PROTEC CM(R) 80/440 (2+0)	508.147		219 x 62 x 47mm	12 pcs.	85g	119
	PROTEC CM 80/150 (1+1)	508.045	1TE	108 x 74 x 24mm	12 pcs.	124g	120
	PROTEC CM 80/275 (1+1)	508.047	1TE	108 x 74 x 24mm	12 pcs.	126g	120
	PROTEC CM 80/320 (1+1)	508.049	1TE	108 x 74 x 24mm	12 pcs.	126g	120
	PROTEC CM 80/385 (1+1)	508.117	1TE	108 x 74 x 24mm	12 pcs.	129g	120
	PROTEC CM 80/440 (1+1)	508.051	1TE	108 x 74 x 24mm	12 pcs.	130g	120
	PROTEC CMR 80/150 (1+1)	508.053	1TE	108 x 74 x 24mm	12 pcs.	129g	120
	PROTEC CMR 80/275 (1+1)	508.055	1TE	108 x 74 x 24mm	12 pcs.	131g	120
	PROTEC CMR 80/320 (1+1)	508.057	1TE	108 x 74 x 24mm	12 pcs.	131g	120
	PROTEC CMR 80/385 (1+1)	508.119	1TE	108 x 74 x 24mm	12 pcs.	134g	120
	PROTEC CMR 80/440 (1+1)	508.059	1TE	108 x 74 x 24mm	12 pcs.	135g	120
	Module PROTEC CM(R) 80/150 (1+1)	508.186		219 x 62 x 47mm	12 pcs.	57g	120
	Module PROTEC CM(R) 80/275 (1+1)	508.187		219 x 62 x 47mm	12 pcs.	59g	120
	Module PROTEC CM(R) 80/320 (1+1)	508.188		219 x 62 x 47mm	12 pcs.	59g	120
	Module PROTEC CM(R) 80/385 (1+1)	508.189		219 x 62 x 47mm	12 pcs.	62g	120
	Module PROTEC CM(R) 80/440 (1+1)	508.190		219 x 62 x 47mm	12 pcs.	63g	120
PROTEC CM 80A/150 (1+1)	508.120	1TE	108 x 74 x 24mm	12 pcs.	124g	120	
PROTEC CM 80A/275 (1+1)	508.122	1TE	108 x 74 x 24mm	12 pcs.	126g	120	

Product name	Ordering code	Dimensions DIN 43880	Packaging dimensions (single unit)	Minimum packaging quantity	Weight	Page
 PROTEC CM 80A/320 (1+1)	508.124	1TE	108 x 74 x 24mm	12 pcs.	126g	120
PROTEC CM 80A/385 (1+1)	508.126	1TE	108 x 74 x 24mm	12 pcs.	129g	120
PROTEC CM 80A/440 (1+1)	508.128	1TE	108 x 74 x 24mm	12 pcs.	130g	120
PROTEC CMR 80A/150 (1+1)	508.130	1TE	108 x 74 x 24mm	12 pcs.	129g	120
PROTEC CMR 80A/275 (1+1)	508.132	1TE	108 x 74 x 24mm	12 pcs.	131g	120
PROTEC CMR 80A/320 (1+1)	508.134	1TE	108 x 74 x 24mm	12 pcs.	131g	120
PROTEC CMR 80A/385 (1+1)	508.136	1TE	108 x 74 x 24mm	12 pcs.	134g	120
PROTEC CMR 80A/440 (1+1)	508.138	1TE	108 x 74 x 24mm	12 pcs.	135g	120
Module PROTEC CM(R) 80A/150 (1+1)	508.176		219 x 62 x 47mm	12 pcs.	57g	120
Module PROTEC CM(R) 80A/275 (1+1)	508.143		219 x 62 x 47mm	12 pcs.	59g	120
Module PROTEC CM(R) 80A/320 (1+1)	508.177		219 x 62 x 47mm	12 pcs.	59g	120
Module PROTEC CM(R) 80A/385 (1+1)	508.144		219 x 62 x 47mm	12 pcs.	62g	120
Module PROTEC CM(R) 80A/440 (1+1)	508.145		219 x 62 x 47mm	12 pcs.	63g	120
Class III Modular and Compact Single and Multi-pole SPD						
 PROTEC D 10/150	508.601	1TE	108 x 74 x 24mm	12 pcs.	124g	126
PROTEC D 10/275	508.603	1TE	108 x 74 x 24mm	12 pcs.	130g	126
PROTEC D 10/320	508.605	1TE	108 x 74 x 24mm	12 pcs.	130g	126
PROTEC D 10/385	508.617	1TE	108 x 74 x 24mm	12 pcs.	131g	126
PROTEC D 10/440	508.607	1TE	108 x 74 x 24mm	12 pcs.	132g	126
PROTEC DR 10/150	508.609	1TE	108 x 74 x 24mm	12 pcs.	129g	126
PROTEC DR 10/275	508.611	1TE	108 x 74 x 24mm	12 pcs.	135g	126
PROTEC DR 10/320	508.613	1TE	108 x 74 x 24mm	12 pcs.	135g	126
PROTEC DR 10/385	508.619	1TE	108 x 74 x 24mm	12 pcs.	136g	126
PROTEC DR 10/440	508.615	1TE	108 x 74 x 24mm	12 pcs.	137g	126
Module PROTEC D(R) 10/150	508.620		219 x 62 x 47mm	12 pcs.	52g	126
Module PROTEC D(R) 10/275	508.621		219 x 62 x 47mm	12 pcs.	58g	126
Module PROTEC D(R) 10/320	508.622		219 x 62 x 47mm	12 pcs.	58g	126
Module PROTEC D(R) 10/385	508.623		219 x 62 x 47mm	12 pcs.	59g	126
Module PROTEC D(R) 10/440	508.624		219 x 62 x 47mm	12 pcs.	60g	126
 PROTEC DM 20/150 (2+0)	508.029	1TE	108 x 74 x 24mm	12 pcs.	136g	127
PROTEC DM 20/275 (2+0)	508.031	1TE	108 x 74 x 24mm	12 pcs.	140g	127
PROTEC DM 20/320 (2+0)	508.033	1TE	108 x 74 x 24mm	12 pcs.	150g	127
PROTEC DM 20/385 (2+0)	508.113	1TE	108 x 74 x 24mm	12 pcs.	153g	127
PROTEC DM 20/440 (2+0)	508.035	1TE	108 x 74 x 24mm	12 pcs.	155g	127
PROTEC DMR 20/150 (2+0)	508.037	1TE	108 x 74 x 24mm	12 pcs.	141g	127
PROTEC DMR 20/275 (2+0)	508.039	1TE	108 x 74 x 24mm	12 pcs.	145g	127
PROTEC DMR 20/320 (2+0)	508.041	1TE	108 x 74 x 24mm	12 pcs.	155g	127
PROTEC DMR 20/385 (2+0)	508.115	1TE	108 x 74 x 24mm	12 pcs.	158g	127
PROTEC DMR 20/440 (2+0)	508.043	1TE	108 x 74 x 24mm	12 pcs.	160g	127
Module PROTEC DM(R) 20/150 (2+0)	508.191		219 x 62 x 47mm	12 pcs.	69g	127
Module PROTEC DM(R) 20/275 (2+0)	508.192		219 x 62 x 47mm	12 pcs.	73g	127
Module PROTEC DM(R) 20/320 (2+0)	508.193		219 x 62 x 47mm	12 pcs.	83g	127
Module PROTEC DM(R) 20/385 (2+0)	508.194		219 x 62 x 47mm	12 pcs.	86g	127
Module PROTEC DM(R) 20/440 (2+0)	508.195		219 x 62 x 47mm	12 pcs.	88g	127
 PROTEC DMG 20/320 (2+0)	508.021	1TE	108 x 74 x 24mm	12 pcs.	118g	128
PROTEC DMGR 20/320 (2+0)	508.027	1TE	108 x 74 x 24mm	12 pcs.	123g	128
Module PROTEC DMG(R) 20/320 (2+0)	508.196		219 x 62 x 47mm	12 pcs.	52g	128
 PROLED 275 (3+1) 16A	130 302	4TE	109 x 76.5 x 78mm	3 pcs.	164g	131
PROLED 275 (4+0) 16A	130 301	4TE	109 x 76.5 x 78mm	3 pcs.	164g	131
 MPE-MINI	121 501		35 x 25 x 12mm	30 pcs.	52g	132
MPE-MINI LED	130 331		35 x 25 x 12mm	30 pcs.	52g	132
 ZE 200-PS	121 532		95 x 150 x 90mm	1 pc	182g	133
 VTC 10/150	122 646		109 x 76.5 x 78mm	100 pcs.	6g	134
VTC 10/275	122 636		109 x 76.5 x 78mm	100 pcs.	8g	134
VTC 10/320	509 313		109 x 76.5 x 78mm	100 pcs.	12g	134
VTC 10/440	122 808		109 x 76.5 x 78mm	100 pcs.	16g	134
 PROFILT D 8A	130 061	2TE	109 x 76.5 x 41.5mm	7 pcs.	94g	135
 PROFILT D 10A	130 051	5TE	109 x 76.5 x 96mm	3 pcs.	420g	136
PROFILT D 16A	130 052	5TE	109 x 76.5 x 96mm	3 pcs.	420g	136
PROFILT D 25A	130 053	5TE	109 x 76.5 x 96mm	3 pcs.	420g	136
PROFILT D 30A	130 050	5TE	109 x 76.5 x 96mm	3 pcs.	420g	136
Modular and Compact SPD for DC Power Systems						
 DC PROTEC B 10/24	510 598	4TE	109 x 76.5 x 78mm	3 pcs.	246g	140
DC PROTEC B 10/48	510 600	4TE	109 x 76.5 x 78mm	3 pcs.	280g	140
DC PROTEC BR 10/24	510 599	4TE	109 x 76.5 x 78mm	3 pcs.	251g	140

Product name	Ordering code	Dimensions DIN 43880	Packaging dimensions (single unit)	Minimum packaging quantity	Weight	Page
 DC PROTEC BR 10/48	510 601	4TE	109 x 76.5 x 78mm	3 pcs.	288g	140
DC PROTEC C 40/24	510 564	2TE	109 x 76.5 x 78mm	3 pcs.	246g	141
DC PROTEC C 40/48	510 566	2TE	109 x 76.5 x 78mm	3 pcs.	280g	141
DC PROTEC CR 40/24	510 565	2TE	109 x 76.5 x 78mm	3 pcs.	251g	141
DC PROTEC CR 40/48	510 567	2TE	109 x 76.5 x 78mm	3 pcs.	288g	141
 PROTEC C 40/75	50.0001	1TE	108 x 74 x 24mm	12 pcs.	112g	142
PROTEC CR 40/75	50.0011	1TE	108 x 74 x 24mm	12 pcs.	117g	142
Module PROTEC C(R) 40/75	50.0216		219 x 62 x 47mm	12 pcs.	44g	142
 PROTEC CN 40/75	507.001	1TE	108 x 74 x 24mm	12 pcs.	127g	143
PROTEC CNR 40/75	507.011	1TE	108 x 74 x 24mm	12 pcs.	132g	143
 PROTEC DMDR 20/24	515 051	1TE	108 x 74 x 24mm	12 pcs.	96g	144
PROTEC DMDR 20/48	515 053	1TE	108 x 74 x 24mm	12 pcs.	96g	144
PROTEC DMDR 20/60	515 054	1TE	108 x 74 x 24mm	12 pcs.	96g	144
PROTEC DMDR 20/120	515 055	1TE	108 x 74 x 24mm	12 pcs.	96g	144
Module PROTEC DMDR 20/24	515 086		219 x 62 x 47mm	12 pcs.	99g	144
Module PROTEC DMDR 20/48	515 087		219 x 62 x 47mm	12 pcs.	99g	144
Module PROTEC DMDR 20/60	515 088		219 x 62 x 47mm	12 pcs.	99g	144
Module PROTEC DMDR 20/120	515 089		219 x 62 x 47mm	12 pcs.	99g	144
 VM-DC 12	7035.02	1TE	108 x 74 x 24mm	12 pcs.	90g	145
VM-DC 24	7035.04	1TE	108 x 74 x 24mm	12 pcs.	90g	145
Module VM-DC 12	7035.01		219 x 62 x 47mm	12 pcs.	30g	145
Module VM-DC 24	7035.03		219 x 62 x 47mm	12 pcs.	30g	145
 SMH-PS 12V	7081.20	2/3TE	102 x 87 x 15mm	15 pcs.	66g	146
SMH-PS 24V	7081.21	2/3TE	102 x 87 x 15mm	15 pcs.	66g	146
SMH-PS 48V	7081.22	2/3TE	102 x 87 x 15mm	15 pcs.	64g	146
Module SMH-PS 12V	7081.25		102 x 87 x 15mm	15 pcs.	22g	146
Module SMH-PS 24V	7081.26		102 x 87 x 15mm	15 pcs.	22g	146
Module SMH-PS 48V	7081.27		102 x 87 x 15mm	15 pcs.	22g	146

Class I, II SPD for Photovoltaic Systems

 SAFETEC B 12.5/300 PV TCG	54.0096	4TE	109 x 76.5 x 78mm	3 pcs.	440g	148
SAFETEC BR 12.5/300 PV TCG	54.0097	4TE	109 x 76.5 x 78mm	3 pcs.	445g	148
SAFETEC B 12.5/600 PV TCG	54.0098	4TE	109 x 76.5 x 78mm	3 pcs.	460g	148
SAFETEC BR 12.5/600 PV TCG	54.0099	4TE	109 x 76.5 x 78mm	3 pcs.	465g	148
SAFETEC B 12.5/1000 PV TCG	54.0102	4TE	109 x 76.5 x 78mm	3 pcs.	800g	148
SAFETEC BR 12.5/1000 PV TCG	54.0103	4TE	109 x 76.5 x 78mm	3 pcs.	805g	148
 SAFETEC B 12.5/600 Y PV TCG	54.0100	6TE	109 x 110 x 78mm	2 pcs.	590g	149
SAFETEC BR 12.5/600 Y PV TCG	54.0101	6TE	109 x 110 x 78mm	2 pcs.	600g	149
SAFETEC B 12.5/1000 Y PV TCG	54.0104	6TE	109 x 110 x 78mm	2 pcs.	630g	149
SAFETEC BR 12.5/1000 Y PV TCG	54.0105	6TE	109 x 110 x 78mm	2 pcs.	640g	149
SAFETEC B 12.5/1200 Y PV TCG	54.0106	6TE	109 x 110 x 78mm	2 pcs.	1100g	149
SAFETEC BR 12.5/1200 Y PV TCG	54.0107	6TE	109 x 110 x 78mm	2 pcs.	1110g	149
SAFETEC B 12.5/1500 Y PV TCG	54.0108	6TE	109 x 110 x 78mm	2 pcs.	1160g	149
SAFETEC BR 12.5/1500 Y PV TCG	54.0109	6TE	109 x 110 x 78mm	2 pcs.	1170g	149
 SAFETEC C 75 PV	516.040	2TE	109 x 76.5 x 41.5mm	7 pcs.	246g	151
SAFETEC C 300 PV	516.042	2TE	109 x 76.5 x 41.5mm	7 pcs.	280g	151
SAFETEC C 600 PV	516.044	2TE	109 x 76.5 x 41.5mm	7 pcs.	290g	151
SAFETEC C 1000 PV	516.046	2TE	109 x 76.5 x 41.5mm	7 pcs.	299g	151
SAFETEC CR 75 PV	516.041	2TE	109 x 76.5 x 41.5mm	7 pcs.	251g	151
SAFETEC CR 300 PV	516.043	2TE	109 x 76.5 x 41.5mm	7 pcs.	288g	151
SAFETEC CR 600 PV	516.045	2TE	109 x 76.5 x 41.5mm	7 pcs.	298g	151
SAFETEC CR 1000 PV	516.047	2TE	109 x 76.5 x 41.5mm	7 pcs.	307g	151
Module SAFETEC C(R) 75 PV	516.050		219 x 62 x 47mm	12 pcs.	45g	151
Module SAFETEC C(R) 300 PV	516.051		219 x 62 x 47mm	12 pcs.	68g	151
Module SAFETEC C(R) 600 PV	516.052		219 x 62 x 47mm	12 pcs.	74g	151
Module SAFETEC C(R) 1000 PV	516.053		219 x 62 x 47mm	12 pcs.	78g	151
 SAFETEC C 1000Y PV	516.242	3TE	109 x 76.5 x 60mm	5 pcs.	396g	152
SAFETEC C 1200Y PV	516.048	3TE	109 x 76.5 x 60mm	5 pcs.	390g	152
SAFETEC C 1500Y PV	516.271	3TE	109 x 76.5 x 60mm	5 pcs.	400g	152
SAFETEC CR 1000Y PV	516.243	3TE	109 x 76.5 x 60mm	5 pcs.	402g	152
SAFETEC CR 1200Y PV	516.049	3TE	109 x 76.5 x 60mm	5 pcs.	396g	152
SAFETEC CR 1500Y PV	516.272	3TE	109 x 76.5 x 60mm	5 pcs.	406g	152
Module SAFETEC C(R) 1000Y PV	516.244		219 x 62 x 47mm	12 pcs.	74g	152
Module SAFETEC C(R) 1200Y PV	516.054		219 x 62 x 47mm	12 pcs.	74g	152
Module SAFETEC C(R) 1500Y PV	516.273		219 x 62 x 47mm	12 pcs.	76g	152

Product name	Ordering code	Dimensions DIN 43880	Packaging dimensions (single unit)	Minimum packaging quantity	Weight	Page	
	SAFETEC C 300 PV (2+0) UL	516.105	2TE	109 x 76.5 x 41.5mm	7 pcs.	280g	155
	SAFETEC C 600 PV (2+0) UL	516.107	2TE	109 x 76.5 x 41.5mm	7 pcs.	290g	155
	SAFETEC C 1000 PV (2+0) UL	516.199	2TE	109 x 76.5 x 41.5mm	7 pcs.	299g	155
	SAFETEC CR 300 PV (2+0) UL	516.106	2TE	109 x 76.5 x 41.5mm	7 pcs.	288g	155
	SAFETEC CR 600 PV (2+0) UL	516.108	2TE	109 x 76.5 x 41.5mm	7 pcs.	298g	155
	SAFETEC CR 1000 PV (2+0) UL	516.200	2TE	109 x 76.5 x 41.5mm	7 pcs.	307g	155
Module SAFETEC C(R) 300 PV UL	516.207		219 x 62 x 47mm	12 pcs.	68g	155	
	Module SAFETEC C(R) 600 PV UL	516.208		219 x 62 x 47mm	12 pcs.	74g	155
	Module SAFETEC C(R) 1000 PV UL	516.209		219 x 62 x 47mm	12 pcs.	78g	155
	SAFETEC C 300 PV (3+0) UL	516.598	3TE	109 x 76.5 x 60mm	5 pcs.	358g	156
	SAFETEC C 600 PV (3+0) UL	516.599	3TE	109 x 76.5 x 60mm	5 pcs.	370g	156
	SAFETEC C 1000 PV (3+0) UL	516.600	3TE	109 x 76.5 x 60mm	5 pcs.	396g	156
	SAFETEC C 1200 PV (3+0) UL	516.109	3TE	109 x 76.5 x 60mm	5 pcs.	390g	156
	SAFETEC C 1500 PV (3+0) UL	516.601	3TE	109 x 76.5 x 60mm	5 pcs.	400g	156
	SAFETEC CR 300 PV (3+0) UL	516.594	3TE	109 x 76.5 x 60mm	5 pcs.	364g	156
	SAFETEC CR 600 PV (3+0) UL	516.595	3TE	109 x 76.5 x 60mm	5 pcs.	376g	156
	SAFETEC CR 1000 PV (3+0) UL	516.604	3TE	109 x 76.5 x 60mm	5 pcs.	402g	156
	SAFETEC CR 1200 PV (3+0) UL	516.210	3TE	109 x 76.5 x 60mm	5 pcs.	392g	156
	SAFETEC CR 1500 PV (3+0) UL	516.605	3TE	109 x 76.5 x 60mm	5 pcs.	406g	156
Module SAFETEC C(R) 300 PV UL	516.602		219 x 62 x 47mm	12 pcs.	62g	156	
	Module SAFETEC C(R) 600 PV UL	516.603		219 x 62 x 47mm	12 pcs.	66g	156
	Module SAFETEC C(R) 1000 PV UL	516.604		219 x 62 x 47mm	12 pcs.	74g	156
	Module SAFETEC C(R) 1200 PV UL	516.210		219 x 62 x 47mm	12 pcs.	74g	156
	Module SAFETEC C(R) 1500 PV UL	516.605		219 x 62 x 47mm	12 pcs.	76g	156
	PV PROTEC C 40/100	501.521	2TE	109 x 76.5 x 41.5mm	7 pcs.	274g	159
	PV PROTEC C 40/550	501.527	2TE	109 x 76.5 x 41.5mm	7 pcs.	302g	159
	PV PROTEC C 40/600	501.709	3TE	109 x 76.5 x 60mm	5 pcs.	329g	159
	PV PROTEC C 40/1000	501.543	3TE	109 x 76.5 x 60mm	5 pcs.	398g	159
	PV PROTEC CR 40/100	501.531	2TE	109 x 76.5 x 41.5mm	7 pcs.	279g	159
	PV PROTEC CR 40/550	501.537	2TE	109 x 76.5 x 41.5mm	7 pcs.	307g	159
	PV PROTEC CR 40/600	501.710	3TE	109 x 76.5 x 60mm	5 pcs.	334g	159
	PV PROTEC CR 40/1000	501.547	3TE	109 x 76.5 x 60mm	5 pcs.	403g	159
	Module PV PROTEC C(R) 40/100	50.0496		219 x 62 x 47mm	12 pcs.	46g	159
	Module PV PROTEC C(R) 40/550	50.0497		219 x 62 x 47mm	12 pcs.	58g	159
Module PV PROTEC C(R) 40/600	501.711		219 x 62 x 47mm	12 pcs.	52g	159	
Module PV PROTEC C(R) 40/1000	50.0498		219 x 62 x 47mm	12 pcs.	58g	159	
Class I, II SPD for Wind Systems							
	SAFETEC B 12.5/440 WT TCG	54.0324	2TE	109 x 76.5 x 41.5mm	7 pcs.	371g	162
	SAFETEC BR 12.5/440 WT TCG	54.0325	2TE	109 x 76.5 x 41.5mm	7 pcs.	376g	162
	SAFETEC B 12.5/750 WT TCG	54.0074	2TE	109 x 76.5 x 41.5mm	7 pcs.	400g	162
	SAFETEC BR 12.5/750 WT TCG	54.0075	2TE	109 x 76.5 x 41.5mm	7 pcs.	405g	162
	SAFETEC B 25/440 WT TCG	54.0326	4TE	109 x 76.5 x 78mm	3 pcs.	692g	163
	SAFETEC BR 25/440 WT TCG	54.0327	4TE	109 x 76.5 x 78mm	3 pcs.	697g	163
	SAFETEC B 25/750 WT TCG	54.0076	4TE	109 x 76.5 x 78mm	3 pcs.	800g	163
	SAFETEC BR 25/750 WT TCG	54.0077	4TE	109 x 76.5 x 78mm	3 pcs.	805g	163
	SAFETEC C 440 (3+0) WT	516.652	3TE	109 x 76.5 x 60mm	5 pcs.	397g	165
	SAFETEC C 750 (3+0) WT	516.055	3TE	109 x 76.5 x 60mm	5 pcs.	364g	165
	SAFETEC C 880 (3+0) WT	516.369	3TE	109 x 76.5 x 60mm	5 pcs.	364g	165
	SAFETEC CR 440 (3+0) WT	516.653	3TE	109 x 76.5 x 60mm	5 pcs.	402g	165
	SAFETEC CR 750 (3+0) WT	516.056	3TE	109 x 76.5 x 60mm	5 pcs.	369g	165
	SAFETEC CR 880 (3+0) WT	516.370	3TE	109 x 76.5 x 60mm	5 pcs.	369g	165
Module SAFETEC C(R) 440 WT	516.654		219 x 62 x 47mm	12 pcs.	74g	165	
	Module SAFETEC C(R) 750 WT	516.057		219 x 62 x 47mm	12 pcs.	78g	165
	Module SAFETEC C(R) 880 WT	516.371		219 x 62 x 47mm	12 pcs.	78g	165
	SAFETEC C 440 (3+0) WT UL	516.225	3TE	109 x 76.5 x 60mm	5 pcs.	397g	167
	SAFETEC C 690 (3+0) WT UL	516.227	3TE	109 x 76.5 x 60mm	5 pcs.	364g	167
	SAFETEC C 750 (3+0) WT UL	516.229	3TE	109 x 76.5 x 60mm	5 pcs.	364g	167
	SAFETEC CR 440 (3+0) WT UL	516.226	3TE	109 x 76.5 x 60mm	5 pcs.	402g	167
	SAFETEC CR 750 (3+0) WT UL	516.228	3TE	109 x 76.5 x 60mm	5 pcs.	369g	167
	SAFETEC CR 880 (3+0) WT UL	516.230	3TE	109 x 76.5 x 60mm	5 pcs.	369g	167
Module SAFETEC C(R) 440 WT UL	516.262		219 x 62 x 47mm	12 pcs.	74g	167	
	Module SAFETEC C(R) 690 WT UL	516.263		219 x 62 x 47mm	12 pcs.	78g	167
	Module SAFETEC C(R) 750 WT UL	516.264		219 x 62 x 47mm	12 pcs.	78g	167
PV Combiner Boxes for Photovoltaic Systems							
PVCB I 2-0.6	130 130					170	
PVCB I 4-0.7	130 131					170	
PVCB I 6-0.8	130 132					170	

Product Index

	Product name	Ordering code	Dimensions DIN 43880	Packaging dimensions (single unit)	Minimum packaging quantity	Weight	Page	
	PVCB I 2-1	130 133					170	
	PVCB I 4-1	130 134					170	
	PVCB I 6-1	130 135					170	
	PVCB I 2-0.6-F	130 136					170	
	PVCB I 4-0.7-F	130 137					170	
	PVCB I 6-0.8-F	130 138					170	
	PVCB I 2-1-F	130 139					170	
	PVCB I 4-1-F	130 140					170	
	PVCB I 6-1-F	130 141					170	
	PVCB I 2-0.6 - MS-F	130 142					170	
	PVCB I 4-0.7 - MS-F	130 143					170	
	PVCB I 6-0.8 - MS-F	130 144					170	
	PVCB I 2-1 - MS-F	130 145					170	
	PVCB I 4-1 - MS-F	130 146					170	
	PVCB I 6-1 - MS-F	130 147					170	
	PVCB I 2-0.6 - MS-D	130 148					170	
	PVCB I 4-0.7 - MS-D	130 149					170	
	PVCB I 6-0.8 - MS-D	131 150					170	
	PVCB I 2-1 - MS-D	132 151					170	
	PVCB I 4-1 - MS-D	133 152					170	
	PVCB I 6-1 - MS-D	134 153					170	
	PVCB II 2-0.6	130 154					171	
	PVCB II 4-0.7	130 155					171	
	PVCB II 6-0.8	130 156					171	
	PVCB II 2-1	130 157					171	
	PVCB II 4-1	130 158					171	
	PVCB II 6-1	130 159					171	
	PVCB II 2-0.6-F	130 160					171	
	PVCB II 4-0.7-F	130 161					171	
	PVCB II 6-0.8-F	130 162					171	
	PVCB II 2-1-F	130 163					171	
	PVCB II 4-1-F	130 164					171	
	PVCB II 6-1-F	130 165					171	
	PVCB II 2-0.6-MS F	130 166					171	
	PVCB II 4-0.7-MS F	130 167					171	
	PVCB II 6-0.8-MS-F	130 168					171	
	PVCB II 2-1-MS-F	130 169					171	
	PVCB II 4-1-MS-F	130 170					171	
	PVCB II 6-1-MS-F	130 171					171	
	PVCB II 2-0.6-MS-D	130 172					171	
	PVCB II 4-0.7-MS-D	130 173					171	
	PVCB II 6-0.8-MS-D	130 174					171	
	PVCB II 2-1-MS-D	130 175					171	
	PVCB II 4-1-MS-D	130 176					171	
	PVCB II 6-1-MS-D	130 177					171	
AC Boxes								
	PBS-C80 (2+0)-F16	130 021					174	
	PBS-C80 (1+1)-F16	130 022					174	
	PBS-D10 (2+0)-F16	130 023					174	
	PBL-C160 (4+0)-F16	130 024					174	
	PBL-C160 (3+1)-F16	130 025					174	
	PBS-D40 (4+0)-F16	130 026					174	
	PROFILT PSF - 1/40/320/TT 25 kA	130 086					175	
	PROFILT PSF - 1/40/320/TT 50 kA	130 046					175	
	PROFILT PSF - 1/63/320/TT 25 kA	130 079					175	
	PROFILT PSF - 1/63/320/TT 50 kA	130 070					175	
	PROFILT PSF - 3/40/320/TT 25 kA	130 083					175	
	PROFILT PSF - 3/40/320/TT 50 kA	130 048					175	
PROFILT PSF - 3/63/320/TT 25 kA	130 044					175		
PROFILT PSF - 3/63/320/TT 50 kA	130 056					175		
Class II SPD for Overhead Power Supply								
	PROTEC AQ 25/150	509.017		295 x 245 x 210mm	60 pcs.	104g	178	
	PROTEC AQ 25/275	509.019		295 x 245 x 210mm	60 pcs.	106g	178	
	PROTEC AQ 25/320	509.021		295 x 245 x 210mm	60 pcs.	108g	178	
	PROTEC AQ 25/385	509.045		295 x 245 x 210mm	60 pcs.	110g	178	
	PROTEC AQ 25/440	509.023		295 x 245 x 210mm	60 pcs.	112g	178	
	PROTEC AQ 40/150	509.029		290 x 250 x 210mm	60 pcs.	144g	179	

	Product name	Ordering code	Dimensions DIN 43880	Packaging dimensions (single unit)	Minimum packaging quantity	Weight	Page	
	PROTEC AQ 40/275	509.031		290 x 250 x 210mm	60 pcs.	146g	179	
	PROTEC AQ 40/320	509.033		290 x 250 x 210mm	60 pcs.	149g	179	
	PROTEC AQ 40/385	509.047		290 x 250 x 210mm	60 pcs.	154g	179	
	PROTEC AQ 40/440	509.035		290 x 250 x 210mm	60 pcs.	157g	179	
	PROTEC AQS 40/150	509.049		382 x 349 x 250mm	100 pcs.	122g	180	
	PROTEC AQS 40/275	509.051		382 x 349 x 250mm	100 pcs.	126g	180	
	PROTEC AQS 40/320	509.053		382 x 349 x 250mm	100 pcs.	130g	180	
	PROTEC AQS 40/440	509.055		382 x 349 x 250mm	100 pcs.	134g	180	
Isolating Spark Gap (ISG) for Equipotential Bonding								
	EPZ-100/350	509.509		310 x 330 x 160mm	20 pcs.	500g	182	
	EPZ-100/500	509.511		310 x 330 x 160mm	20 pcs.	500g	182	
	EPZ-100/350 Ex	322.973		310 x 330 x 160mm	20 pcs.	500g	183	
	EPZ-100/500 Ex	322.975		310 x 330 x 160mm	20 pcs.	500g	183	
Connection Accessories								
	PROSHORT	501 101		108 x 74 x 24mm	12 pcs.	72g	186	
	PRONET S 35	501 001		109 x 76.5 x 41.4mm	7 pcs.	438g	187	
	PRONET S 63	501 003		109 x 76.5 x 78mm	3 pcs.	541g	187	
	PROBAR 1-2	501 301					188	
	PROBAR 1-3	501 303					188	
	PROBAR 1-4	501 305					188	
	PROBAR 1-5	501 307					188	
	PROBAR 1-6	501 309					188	
	PROBAR 1-7	501 311					188	
	PROBAR 1-8	501 313					188	
	PROBAR 1-11	501 315					188	
		PROBAR 2-8	501 317					189
		PROBAR 3-6	501 319					189
		PROBAR 3-8	501 321					189
	PB 1-(2+0)	501 331					189	
	PB 1-(3+0)	501 332					189	
	PB 1-(4+0)	501 335					189	
	PB 1-(3+1)	501 334					189	
		Fixing cable	509 507					190
	Fixing hook	509 501					190	
	PSN	509 503					190	
	PSI	509 505					190	
								190
ProGRID Series - Power Quality Accessories								
Surge and Lightning counter Family								
	ProSEC I	130 090		109 x 76.5 x 41.5mm		140g	192	
	ProSEC II+	130 092		110 x 83 x 42mm		150g	193	
	ProSEC III	130 601		109 x 76.5 x 96mm		230g	194	
	ProLEC I	130 520		191 x 87 x 47mm		420g	195	
SPD Life-status Monitoring Accessories								
	ProALARM I	130 510		108 x 74 x 24mm		80g	196	
	ProALARM II	130 560		106 x 73.5 x 58mm		140g	197	
	ProSLS	130 550		106 x 73.5 x 58mm		180g	198	
	ProAlyser	130 500		147 x 109 x 76.5mm		580g	199	
	ProSTE	130 530		109 x 76.5 x 41.5mm		170g	201	



QR code

With the QR code you have direct access to our web site.

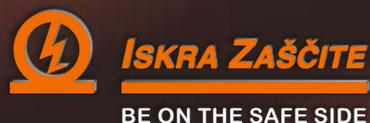

ISKRA ZAŠČITE

BE ON THE SAFE SIDE

ISKRA ZAŠČITE d. o. o.

Surge Protection Systems, Engineering & Cooperation

Stegne 23 A, SI - 1000 Ljubljana, Slovenia

T +386 1 5003 100

F +386 1 5003 236

E info@iskrazascite.si

W www.iskrazascite.si

We reserve the right to introduce changes in performance, dimensions and materials in the course of technical progress.

Copyright All rights reserved. No part of this work, nor of the information laid down herein and/or derivable herefrom and/or developed in connection herewith, may be reproduced or used in any form or by any means. Legal action will be taken against infringements.

This publication replaces the previous edition