



HIRSCHMANN

A **BELDEN** BRAND

User Manual

Installation

Industrial ETHERNET Rail Switch

RS20/RS22/RS30/RS32/RS40 Family

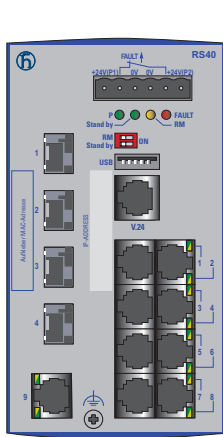

RS40-0009...

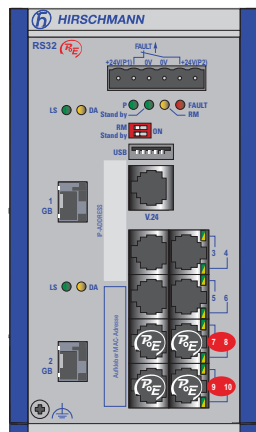

RS32-0802...

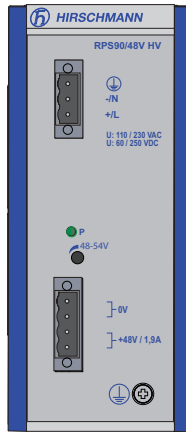

RPS90/48V HV

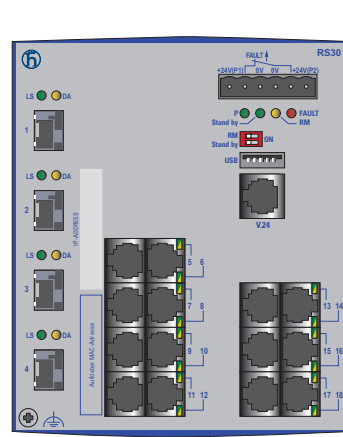

RS30-1602...

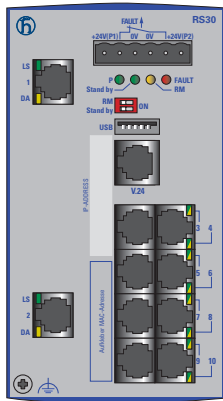

RS30-0802...

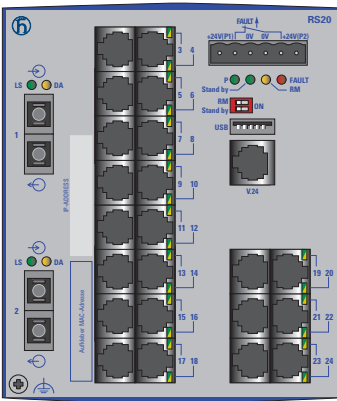

RS20-2400...

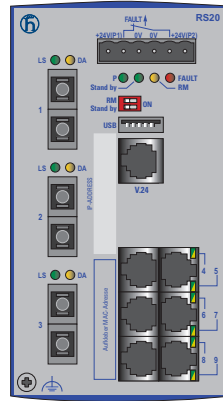

RS20-0900...

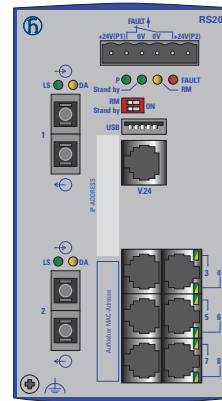

RS20-0800...

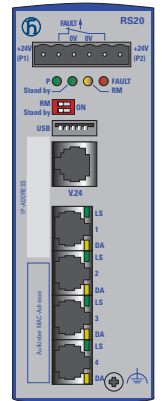

RS20-0400...



039692002171010000

The naming of copyrighted trademarks in this manual, even when not specially indicated, should not be taken to mean that these names may be considered as free in the sense of the trademark and tradename protection law and hence that they may be freely used by anyone.

© 2010 Hirschmann Automation and Control GmbH

Manuals and software are protected by copyright. All rights reserved. The copying, reproduction, translation, conversion into any electronic medium or machine scannable form is not permitted, either in whole or in part. An exception is the preparation of a backup copy of the software for your own use. For devices with embedded software, the end-user license agreement on the enclosed CD applies.

The performance features described here are binding only if they have been expressly agreed when the contract was made. This document was produced by Hirschmann Automation and Control GmbH according to the best of the company's knowledge. Hirschmann reserves the right to change the contents of this document without prior notice. Hirschmann can give no guarantee in respect of the correctness or accuracy of the information in this document.

Hirschmann can accept no responsibility for damages, resulting from the use of the network components or the associated operating software. In addition, we refer to the conditions of use specified in the license contract.

You can get the latest version of this manual on the Internet at the Hirschmann product site (www.beldensolutions.com).

Printed in Germany
Hirschmann Automation and Control GmbH
Stuttgarter Str. 45-51
72654 Neckartenzlingen
Germany
Tel.: +49 1805 141538

Contents

Safety instructions	4
About this Manual	11
Key	11
1 Device description	12
1.1 Description of the device variants	14
1.1.1 Combination options for RS20/30	16
1.1.2 Combination options for RS40	19
1.1.3 Number of ports and media for RS20-...	20
1.1.4 Number of ports and media for RS30-...	24
1.1.5 Number of ports and media for RS40-...	27
1.2 Device variants with PoE (optional)	28
1.2.1 Number of ports and media for devices with PoE	28
1.2.2 PoE power units	30
2 Assembly and start-up	31
2.1 Installing the device	31
2.1.1 Unpacking and checking	31
2.1.2 Installing the SFP modules (optional)	32
2.1.3 Insert data in label area	32
2.1.4 Adjust DIP switch settings	33
2.1.5 RS20/RS30/RS40: supply voltage and signal contact	33
2.1.6 RS22/RS32: supply voltage and signal contact	35
2.1.7 Installing the device on the DIN rail, grounding	38
2.1.8 Dimension drawings	41
2.1.9 Connecting the ferrite	44
2.1.10 Installing the terminal block, start-up procedure	44
2.1.11 Connecting the data lines	44
2.2 Display elements	48
2.3 Basic set-up	50
2.4 Disassembly	52
3 Technical data	53
A Further Support	63

Safety instructions

■ Notes on safety

This manual contains instructions to be observed for ensuring your personal safety and for preventing damage. The warnings appear next to a warning triangle with a different heading depending on the degree of danger posed:



Danger!

Means that death, serious physical injury or significant damage to property **will occur** if the corresponding safety measures are not carried out.



Warning!

Means that death, serious physical injury or significant damage to property **could occur** if the corresponding safety measures are not carried out.



Caution!

Means that minor physical injury or damage to property can occur if the required safety measures are not carried out.

Note: Contains important information on the product, on how to manage the product, or on the respective section of the documentation to which your special attention is being drawn.

■ Certified usage

Please observe the following: The device may only be employed for the purposes described in the catalog and technical description, and only in conjunction with external devices and components recommended or approved by the manufacturer. The product can only be operated correctly and safely if it is transported, stored, installed and assembled properly and correctly. Furthermore, it must be operated and serviced carefully.

■ Supply voltage

For safety reasons the devices have been designed to operate at low voltages. Thus, they may only be connected to the supply voltage connections and to the signal contact with SELV circuits with the voltage restrictions in accordance with IEC/EN 60950-1.

The supply voltage is electrically isolated from the housing.

Use undamaged parts.

- Relevant for North America: For use in Class 2 circuits.
The device may only be connected to a supply voltage of class 2 that fulfills the requirements of the National Electrical Code, Table 11(b). If the voltage is being supplied redundantly (two different voltage sources), the combined supply voltages must fulfill the requirements of the National Electrical Code, Table 11(b).
- Relevant for North America: For use in Class 2 circuits.
Only use copper wire/conductors of class 1, 75 °C (167 °F).
- Relevant for North America
for devices certified for hazardous locations:
Power, input and output (I/O) wiring must be in accordance with Class I, Division 2 wiring methods [Article 501-4(b) of the National Electrical Code, NFPA 70] and in accordance with the authority having jurisdiction.
- Relevant for RS20 devices and RS30 devices used in explosive gas atmospheres according to ATEX Directive 94/9 EC:
 - ▶ Make sure that the device has the following label:
 II 3G (... followed by other specifications).
 - ▶ The product must be mounted in a suitable IP 54-certified housing – tested to 4 J impact to minimize the risk of mechanical damage.
 - ▶ For ambient temperatures below -10 °C and above +60 °C use wiring suitable for both the minimum and maximum temperatures.
 - ▶ Connectors may be connected exclusively in dead-voltage state.
 - ▶ DIP switches may be switched exclusively in dead-voltage state.
- The device does not contain any service components. Internal fuses are only triggered if there is a fault in the device. If the device is not functioning correctly, or if it is damaged, switch off the voltage supply and return the device to the plant for inspection.
- Only switch on the supply voltage to the device if
 - the housing is closed,
 - the terminal blocks are wired up correctly and
 - the terminal blocks are connected.

■ **Supply voltage for PoE power supply units (optional)**

- Connect the protective conductor with the ground screw before you set up the other connections. When removing the connections, you remove the protective conductor last.
- Make sure that the cross-section of the protective conductor cable is the same size as or bigger than the cross-section of the voltage supply cables.
- Only use connection cables that are permitted for the specified temperature range.



Warning!

- If the neutral conductor or the negative terminal of the supply voltage is not grounded
- If you are using a DC voltage greater than 125 V DC for the supply voltage install a suitable input fuse.

For RPS90/48V-LV power supply units, use a slow-blow fuse with a nominal rating of 10 A for the voltage supply input.

For RPS90/48V-HV power supply units, use a slow-blow fuse with a nominal rating of 6.3 A.

With AC power supply, use a cable cross-section of at least 0.75 mm² (for North America AWG 18) for the current conductor at the voltage input.

With DC power supply, use a cable cross-section of at least 1.0 mm² (for North America AWG 16) for the current conductor at the voltage input.



Warning!

Only connect a supply voltage that corresponds to the type plate of your device.

- ▶ PoE power supply unit RPS90/48V LV: 18 V DC to 60 V DC
- ▶ PoE power supply unit RPS90/48V HV: 48 V DC to 320 V DC or 90 V AC to 265 V AC

■ Shielding ground

Note: The shielding ground of the connectable twisted pair lines is connected to the front panel as a conductor.

- Beware of possible short circuits when connecting a cable section with conductive shielding braiding.

■ ATEX Directive 94/9 EC

Relevant for RS40 devices used in explosive gas atmospheres according to ATEX Directive 94/9 EC:

- Make sure that the device has the following label:

- The modules shall be installed in an enclosure in accordance with EN 60079-15 providing a degree of protection of at least IP54 according to EN 60529, taking into account the environmental conditions under which the equipment will be used.
- When the temperature under rated conditions exceeds 70 °C at the cable or conduit entry point, or 80 °C at the branching point of the conductors, the temperature specification of the selected cable shall be in compliance with the actual measured temperature values.
- Provisions shall be made to prevent the rated voltage from being exceeded by transient disturbances of more than 40%.

■ Housing



Warning!

Never insert sharp objects (small screwdrivers, wires, etc.) into the inside of the product. There is the risk of an electric shock.



Warning!

When installing the device, make sure the ventilation slots remain free, as otherwise damage can occur through overheating.

Only technicians authorized by the manufacturer are permitted to open the housing.

The housing is grounded via the separate ground screw on the bottom left of the front panel.

For the ground conductor, use a cable with a cross section of at least 1.0 mm².

- The clearance to the ventilation slots of the housing must be at least 10 cm (3.94 in).
- The device must be installed in the vertical position.
- If installed in a living area or office environment, the device must be operated exclusively in switch cabinets with fire protection characteristics in accordance with EN 60950-1.

■ Environment

The device may only be operated at the specified surrounding air temperature (temperature of the surrounding air at a distance of up to 5 cm (1.97 in) from the device) and relative air humidity specified in the technical data.

- Install the device in a location where the climatic threshold values specified in the technical data will be observed.
- Use the device only in an environment within the contamination level specified in the technical data.

■ **Qualification requirements for personnel**

Qualified personnel as understood in this manual and the warning signs, are persons who are familiar with the setup, assembly, startup, and operation of this product and are appropriately qualified for their job. This includes, for example, those persons who have been:

- ▶ trained or directed or authorized to switch on and off, to ground and to label power circuits and devices or systems in accordance with current safety engineering standards;
- ▶ trained or directed in the care and use of appropriate safety equipment in accordance with the current standards of safety engineering;
- ▶ trained in providing first aid.

■ **General safety instructions**

Electricity is used to operate this equipment. Comply with every detail of the safety requirements specified in the operating instructions regarding the voltages to apply (see [page 4](#)).

Non-observance of these safety instructions can therefore cause material damage and/or serious injuries.

- Only appropriately qualified personnel should work on this device or in its vicinity. These personnel must be thoroughly familiar with all the warnings and maintenance procedures in accordance with this operating manual.
- The proper and safe operation of this device depends on proper handling during transport, proper storage and assembly, and conscientious operation and maintenance procedures.
- Never start operation with damaged components.
- Only use the devices in accordance with this manual. In particular, observe all warnings and safety-related information.
- Any work that may be required on the electrical installation may only be carried out by personnel trained for this purpose.

Note: LED or LASER components in compliance with IEC 60825-1 (2001):

CLASS 1 LASER PRODUCT

CLASS 1 LED PRODUCT

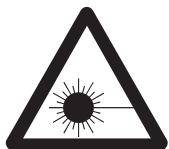

Warning

Laser light

Do not look into the beam or view it directly with optical instruments (e.g. magnifying glasses, microscopes).

Failure to observe this warning within a distance of 100 mm

can endanger your sight.

Light is emitted from the optical connections or from the ends of the optical fibers that are connected to them. Light Emitting Diode CLASS 2M, wave length 650 nm, power <2 mW, according to DIN EN 60825-1:2003-10.

■ **National and international safety regulations**

- Make sure that the electrical installation meets local or nationally applicable safety regulations.

■ **CE marking**

The devices comply with the regulations contained in the following European directive(s):

2004/108/EG

Directive of the European Parliament and the council for standardizing the regulations of member states with regard to electromagnetic compatibility.

RPS90/48V HV:

2006/95/EG

Directive of the European Parliament and the council for standardizing the regulations of member states with regard to electrical equipment to be used within specific voltage ranges.

RPS90/48V LV:

72/245/EWG, 2004/104/EG, 2009/19/EGEG

Guideline for standardizing the regulations of member states relating to radio interference from motor vehicles. Certified devices are marked with an e1 type approval indicator.

In accordance with the above-named EU directive(s), the EU conformity declaration will be at the disposal of the relevant authorities at the following address:

Hirschmann Automation and Control GmbH

Stuttgarter Str. 45-51

72654 Neckartenzlingen

Tel.: +49 1805 141538

The product can be used in living areas (living area, place of business, small business) and in industrial areas.

- ▶ Interference immunity: EN 61000-6-2:2005
- ▶ Emitted interference: EN 55022:2006 + A1:2007 Class A



Warning!

This is a class A device. This device can cause interference in living areas, and in this case the operator may be required to take appropriate measures.

The assembly guidelines provided in these instructions must be strictly adhered to in order to observe the EMC threshold values.

■ **FCC note:**

This device complies with part 15 of FCC rules. Operation is subject to the following two conditions : (1) This device may not cause harmful interference; (2) this device must accept any interference received, including interference that may cause undesired operation.

Appropriate testing has established that this device fulfills the requirements of a class A digital device in line with part 15 of the FCC regulations.

These requirements are designed to provide sufficient protection against interference when the device is being used in a business environment.

The device creates and uses high frequencies and can radiate same, and if it is not installed and used in accordance with this operating manual, it can cause radio transmission interference. The use of this device in a living area can also cause interference, and in this case the user is obliged to cover the costs of removing the interference.

■ **Recycling note**

After usage, this product must be disposed of properly as electronic waste, in accordance with the current disposal regulations of your county, state and country.

About this Manual

The “Installation” user manual contains a device description, safety instructions, a description of the display, and the other information that you need to install the device.

The following manuals are available as PDF files on the CD-ROM supplied:

- ▶ Installation user manual
- ▶ Basic Configuration user manual
- ▶ Redundancy Configuration user manual
- ▶ Web-based Interface reference guide
- ▶ Command Line Interface user manual

The Network Management Software HiVision/Industrial HiVision provides you with additional options for smooth configuration and monitoring:

- ▶ Configuration of multiple devices simultaneously.
- ▶ Graphical interface with network layouts.
- ▶ Auto-topology discovery.
- ▶ Event log.
- ▶ Event handling.
- ▶ Client / Server structure.
- ▶ Browser interface
- ▶ ActiveX control for SCADA integration
- ▶ SNMP/OPC gateway

Key

The symbols used in this manual have the following meanings:

▶	Listing
□	Work step
■	Subheading

1 Device description

The RS20/22/30/32/40 family provides you with a range of Switch variants. You can set up your device individually based on different criteria:

- ▶ Number of ports
- ▶ Transmission speed
- ▶ Media type
- ▶ Types of connectors
- ▶ Temperature range
- ▶ Certifications
- ▶ Software variant

The RS20/22/30/32/40 devices are designed for the special requirements of industrial automation. They meet the relevant industry standards, provide very high operational reliability, even under extreme conditions, and also long-term reliability and flexibility.

The devices allow you to set up switched industrial ETHERNET networks that conform to the IEEE 802.3 and 802.3u standards using copper wires or optical fibers in a line or ring structure.

The devices work without a fan.

The voltage is supplied redundantly.

Mount the devices by

- ▶ simply snapping them onto a DIN rail
- ▶ mounting them on a wall (only RS22/RS32)

Depending on the device variant, you can choose various media to connect terminal devices and other infrastructure components:

- ▶ twisted pair cable
- ▶ multimode F/O
- ▶ singlemode F/O

The twisted pair ports support:

- ▶ Autocrossing
- ▶ Autonegotiation
- ▶ Autopolarity

There are a number of convenient options for managing the device.

Administer your devices via:

- ▶ a Web browser
- ▶ Telnet
- ▶ management software (e.g. HiVision)
- ▶ a V.24 interface (locally on the Switch)

The HIPER-Ring redundancy concept enables a quick reconfiguration. With one additional connection, projection remains simple.

Product configuration data can be provided by:

- ▶ diagnosis displays
- ▶ displaying the operating parameters
- ▶ a label area for the IP address

Depending on the software you choose, the devices provide you with a large range of functions:

- ▶ Redundancy functions
 - ▶ Rapid Spanning Tree Protocol (RSTP)
 - ▶ Redundant ring structure
 - ▶ HIPER-Ring
 - ▶ Redundant coupling
 - ▶ Link aggregation
 - ▶ Redundant power supply
- ▶ Security
 - ▶ Protection from unauthorized access
 - ▶ Blocking of unauthorized messages (MAC or IP based)
- ▶ Synchronized system time in the network
- ▶ Network load control
- ▶ Operation diagnosis
- ▶ Diagnostics (hardware self-testing)
- ▶ Reset
- ▶ Priority
- ▶ VLAN
- ▶ Topology Discovery
- ▶ Web-based Interface
- ▶ Command Line Interface CLI
- ▶ SNMP
- ▶ 802.1x port authentication
- ▶ Real Time Clock

The Hirschmann network components help you to establish continuous communication across all levels of the company. Connect your devices to:

- ▶ devices of the MICE family
- ▶ backbone devices of the MACH family
- ▶ the BAT wireless transmission system
- ▶ the EAGLE security system
- ▶ products for the LION control room / MACH 100 family

1.1 Description of the device variants

The devices differ with regard to the range of software functions, the number of interfaces, and the media type for connecting segments.

The table below shows three port categories for each product variant: uplink ports, PoE ports and other ports. The table also shows for each product category the number of ports you can select, and the type of ports. In the column for the port type, the abbreviations F/O (optical fiber) and TP (twisted pair) indicate the media type, while the abbreviations DSC, ST, SFP and RJ45 indicate the socket type.

Variant	Uplink ports		Other ports		PoE ports included	
	Number	Type	Number	Type	Number	Type
RS20-...	2	Ports 1 and 2 10/100 Mbit/s, media selectable, DSC, ST, RJ45	2, 6, 14, 22	10/100 Mbit/s, TP, RJ45	—	—
	3	Ports 1 to 3 10/100 Mbit/s, media selectable, DSC, ST, RJ45	6, 14, 22	10/100 Mbit/s, TP, RJ45	—	—
RS22-...	2	Ports 1 and 2 10/100 Mbit/s, media selectable, DSC, ST, RJ45	6, 14, 22	10/100 Mbit/s, TP, RJ45	4	10/100 Mbit/s, TP, RJ45
	3	Ports 1 to 3 10/100 Mbit/s, media selectable, DSC, ST, RJ45	6, 14, 22	10/100 Mbit/s, TP, RJ45	4	10/100 Mbit/s, TP, RJ45
RS30-...	2	Ports 1 and 2 1000 Mbit/s, media selectable, SFP, RJ45	8, 16, 24	10/100 Mbit/s, TP, RJ45	—	—
	4	Ports 1+2, 3+4 2x100/1000 Mbit/s, 2x 100 Mbit/s, F/O, SFP	6, 14, 22	10/100 Mbit/s, TP, RJ45	—	—
RS32-...	2	Ports 1 and 2 1000 Mbit/s, media selectable, SFP, RJ45	8, 16, 24	10/100 Mbit/s, TP, RJ45	4	10/100 Mbit/s, TP, RJ45
	4	Ports 1+2, 3+4 2x100/1000 Mbit/s, 2x 100 Mbit/s, F/O, SFP	6, 14, 22	10/100 Mbit/s, TP, RJ45	4	10/100 Mbit/s, TP, RJ45
RS40-...	4	Ports 1 to 4 4 combo ports: 100/1000 Mbit/s, F/O, SFP 10/100/1000 Mbit/s, TP, RJ45	5	10/100/ 1000 Mbit/s, TP, RJ45	—	—

Table 1: Number and type of ports

The devices also provide you with the following options for selecting the variant you desire:

Operating temperature	Standard	0 °C to +60 °C
	Extended	-40 °C to +70 °C
	Extended with conformal coating	-40 °C to +70 °C
	Extended with PoE devices	-40 °C to +50 °C
Operating voltage	Standard	9.6 to 60 V DC or 18 to 30 V AC Safety extra-low voltage (SELV), redundant inputs disconnected.
	PoE	48 V (47 V DC to 52 V DC)
Certifications / declarations	CE, UL508, ISA 12.12.01 (UL1604)	
	CE, UL508, ISA 12.12.01 (UL1604), Germanischer Lloyd (GL), IEC/EN 61850-3 declaration (sub station), IEEE 1613 (sub station), EN 50121-4 railway (along track)	
	CE, UL508, ISA 12.12.01 (UL1604), Germanischer Lloyd (GL), IEC/EN 61850-3 declaration (sub station), IEEE 1613 (sub station), EN 50121-4 railway (along track), ATEX RL 94/9 EG (hazardous location)	
Software variant	Enhanced Professional	

The devices comply with the specifications of the standard(s):

- ▶ ISO/IEC 8802-03 10BASE-T/100BASE-TX/1000BASE-T
- ▶ ISO/IEC 8802-03 100BASE-FX
- ▶ ISO/IEC 8802-03 1000BASE-SX/LX

1.1.1 Combination options for RS20/30

The product designation of your device is made from combining the desired product characteristics in accordance with the following table. You will find the corresponding short designation in columns 3 and 4.

Item	Characteristic	Ident.	Ident. 2 ^{a)}	Property
1 to 4	Product	RS20		Rail Switch without gigabit ports
		RS30		Rail Switch with gigabit ports
		RS22		Rail Switch without gigabit ports, with PoE ^{b)c)}
		RS32		Rail Switch with gigabit ports, with PoE ^{b)c)}
5	- (hyphen)	-		
6 to 7	Number of 10/100 Mbit/s ports	04		4 * 10/100 Mbit/s Ethernet
		08		8 * 10/100 Mbit/s Ethernet
		09		9 * 10/100 Mbit/s Ethernet
		16		16 * 10/100 Mbit/s Ethernet
		17		17 * 10/100 Mbit/s Ethernet
		24		24 * 10/100 Mbit/s Ethernet
		25		25 * 10/100 Mbit/s Ethernet
8 and 9	Number of 1000 Mbit/s ports	00		0 * 1000 Mbit/s Ethernet
		02		2 * 1000 Mbit/s Ethernet (not for 4-port devices) ^{b)}
10 and 11 ^{a)}	Uplink port(s) 1 port (Ident. column) or alternatively 2 ports (Ident.2 column)	T1		Twisted pair T(X), RJ45
		M2	MM ^{d)}	Multimode FX, DSC, 100 Mbit/s
		M4	NN ^{d)}	Multimode FX, ST, 100 Mbit/s
		S2	VV ^{d)}	Singlemode FX, DSC, 100 Mbit/s
		S4	UU ^{d)}	Singlemode FX, ST, 100 Mbit/s
		E2	EE ^{d)e)}	Singlemode+ FX, DSC, 100 Mbit/s
		L2	LL ^{d)}	Singlemode Longhaul, DSC, 100 Mbit/s
		G2	GG ^{d)}	Singlemode Longhaul FX DSC 200 km, 100 Mbit/s
		O6	OO ^{b)f)}	SFP slot, 1000 Mbit/s
Z6	ZZ ^{b)f)}	SFP slot, 100 Mbit/s		
12 and 13 ^{a)}	See items 10 and 11			
14	Temperature range	S		Standard 0 °C to +60 °C
		T		Extended -40 °C to +70 °C ^{g)}
		E		Extended -40 °C to +70 °C, conformal coating ^{f)}
15	Voltage range incl. maximum tolerances	D ^{h)}		9.6 V DC to 60 V DC or 18 V AC to 30 V AC
		P ⁱ⁾		47 V DC to 52 V DC (PoE)
16	Certification	A		CE, UL 508, ISA 12.12.01 (UL 1604)
		H		CE, UL 508, ISA 12.12.01 (UL 1604), GL, Railway (along track), Sub Station
		B ^{j)}		CE, UL 508, ISA 12.12.01 (UL 1604), GL, Railway (along track), Sub Station, Hazardous Location (ATEX)
17	Software variant	E		Enhanced
		P		Professional

Table 2: Combination options of device variants RS20/RS30/RS22/RS32

- a. For device variants with two uplink ports you use the "Ident." column for items 10+11 and for items 12+13.
For device variants with three uplink ports you use the "Ident.2" column for items 10+11 and the "Ident." column for items 12+13.
For device variants with four uplink ports you use the "Ident.2" column for items 10+11 and for items 12+13.
- b. Not in combination with "04 * 100 Mbit/s Ethernet".
- c. The last four ports of the device have PoE (Power over Ethernet).
- d. For RS20-0900..., RS20-1700..., RS20-2500...;
RS22-0900..., RS22-1700..., RS22-2500...
- e. Devices with ports with product code E2 or EE: only certification "A" available (see product code for item 16).
- f. In connection with "2nd uplink port" "ZZ" and "1st uplink port" "OO".
- g. Not when using GG or G2 transceivers.
Temperature range for PoE-capable devices (RS22-..., RS32-...): -40 °C to +50 °C
- h. Not for PoE-capable devices (RS22-..., RS32-...).
- i. For PoE-capable devices (RS22-..., RS32-...).
- j. Without railway certification EN50155 (Train).

■ Examples for product name

RS20-	Rail Switch without gigabit ports
09	9 * 100 Mbit/s Ethernet ports
00	0 * 1000 Mbit/s Ethernet ports
MM	Port 1 + 2 = 2 * Multimode FX, DSC, 100 Mbit/s
M2	Port 3 = Multimode FX, DSC, 100 Mbit/s
S	Temperature range standard: 0 °C to +60 °C
D	Voltage range: 9.6 V DC to 60 V DC or 18 V AC to 30 V AC
A	Certifications: CE, UL 508, ISA 12.12.01 (UL 1604)
P	Software variant: Professional

Table 3: Example of RS20 with 3 uplink ports: RS20-0900MMM2SDAP

RS30-	Rail Switch with gigabit ports
08	8 * 100 Mbit/s Ethernet ports
02	2 * 1000 Mbit/s Ethernet ports
O6	Port 1 = SFP slot, 1000 Mbit/s
T1	Port 2 = twisted pair TX, RJ45 connector, 1000 Mbit/s
T	Temperature range extended: -40 °C to +70 °C
D	Voltage range: 9.6 V DC to 60 V DC or 18 V AC to 30 V AC
A	Certifications: CE, UL 508, ISA 12.12.01 (UL 1604)
E	Software variant: Enhanced

Table 4: Example of RS30 with 2 uplink ports: RS30-0802O6T1TDAE

Additional examples of devices with 3 or 4 uplink ports:

- ▶ RS20-0900**NNM4**TDAE for RS20 with 3 uplink ports (ST)
 - NN**: 2 * Multimode FX, ST, 100 Mbit/s (ports 1 and 2)
 - M4**: 1 * Multimode FX, ST, 100 Mbit/s (port 3)

- ▶ RS30-2402**OOZZ**TDAP for RS30 with 4 uplink ports (SFP)
 - OO**: 2 * SFP slot, 1000 Mbit/s (ports 1 and 2)
 - ZZ**: 2 * SFP slot, 100 Mbit/s (ports 3 and 4)

Example of device with Power over Ethernet:

- ▶ RS32-0802**O6T1**SPAP for RS32 with 2 uplink ports and PoE
 - O6**: 1 * SFP slot, 1000 Mbit/s (port 1)
 - T1**: 1 * twisted pair TX, RJ45, 1000 Mbit/s (port 2)
 - P**: Voltage range 47 V DC to 52 V DC (PoE)

1.1.2 Combination options for RS40

The product designation of your device is made from combining the desired product characteristics in accordance with the following table. The corresponding short designation is in column 3.

Item	Characteristic	Ident.	Property
1 to 4	Product	RS40	Rail Switch with gigabit ports
5	- (hyphen)	-	
6 to 7	Number of 10/100 Mbit/s ports	00	0 * 10/100 Mbit/s Ethernet
8 and 9	Number of 1000 Mbit/s ports	09	9 * 1000 Mbit/s Ethernet
10 and 11	1st + 2nd uplink ports	CC	2 * combo port multirate (SFP slot: 100/1000 Mbit/s, alternatively twisted pair RJ45 socket: 10/100/1000 Mbit/s)
12 and 13	3rd + 4th uplink ports	CC	2 * combo port multirate (SFP slot: 100/1000 Mbit/s, alternatively twisted pair RJ45 socket: 10/100/1000 Mbit/s)
14	Temperature range	S	Standard 0 °C to +60 °C
		T	Extended -40 °C to +70 °C
		E	Extended -40 °C to +70 °C, conformal coating
15	Voltage range	D	9.6 V DC to 60 V DC or 18 V AC to 30 V AC
16	Certification	A	CE, UL 508, ISA 12.12.01 (UL 1604)
		H	CE, UL 508, GL, Railway (along track), Sub Station Pending: ISA 12.12.01 (UL 1604)
		B	CE, UL 508, GL, Railway (along track), Sub Station Pending: ISA 12.12.01 (UL 1604), Hazardous Location (ATEX)
17	Software variant	E	Enhanced
		P	Professional

Table 5: Combination options for the device variants of the RS40

■ Examples for product name

RS40-	Rail Switch with gigabit ports
00	0 * 100 Mbit/s Ethernet ports
09	9 * 1000 Mbit/s Ethernet ports
CC	Ports 1 + 2 = combo port: SFP slot (100/1000 Mbit/s), alternatively: RJ45 connector (10/100/1000 Mbit/s)
CC	Ports 3 + 4 = combo port: SFP slot (100/1000 Mbit/s), alternatively: RJ45 connector (10/100/1000 Mbit/s)
E	Temperature range extended (-40 °C to +70 °C) with conformal coating
D	Voltage range: 9.6 V DC to 60 V DC or 18 V AC to 30 V AC
A	Certifications: CE, UL 508, ISA 12.12.01 (UL 1604)
P	Software variant: Professional

Table 6: Example of RS40 with 4 uplink ports: RS40-0009CCCCEDAP

1.1.3 Number of ports and media for RS20-...

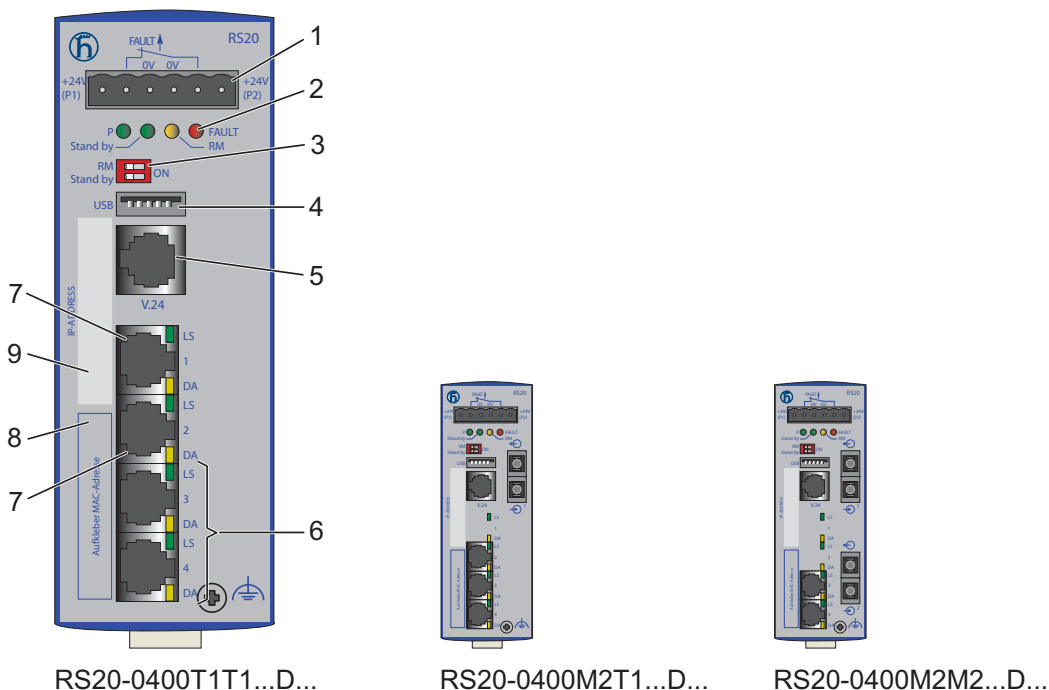

Figure 1: Device variants with 4 * 10/100 Mbit/s ports (RS20-0400...)

- 1 – plug-in terminal block, 6-pin
- 2 – LED display elements
- 3 – 2-pin DIP switch
- 4 – USB interface
- 5 – V.24 connection for external management
- 6 – ports in compliance with 10/100BASE-T(X) (RJ45 connections)
- 7 – port 1 + port 2, free choice of connections:
 - T1: Twisted-pair T(X), RJ45, 10/100 Mbit/s
 - M2: Multimode FX, DSC, 100 Mbit/s

- M4: Multimode FX, ST, 100 Mbit/s
- S2: Singlemode FX, DSC, 100 Mbit/s
- S4: Singlemode FX, ST, 100 Mbit/s
- L2: Singlemode Longhaul FX, DSC, 100 Mbit/s
- G2: Singlemode Longhaul+ FX, DSC, 100 Mbit/s, 200 km
- 8 – MAC address field
- 9 – IP address field

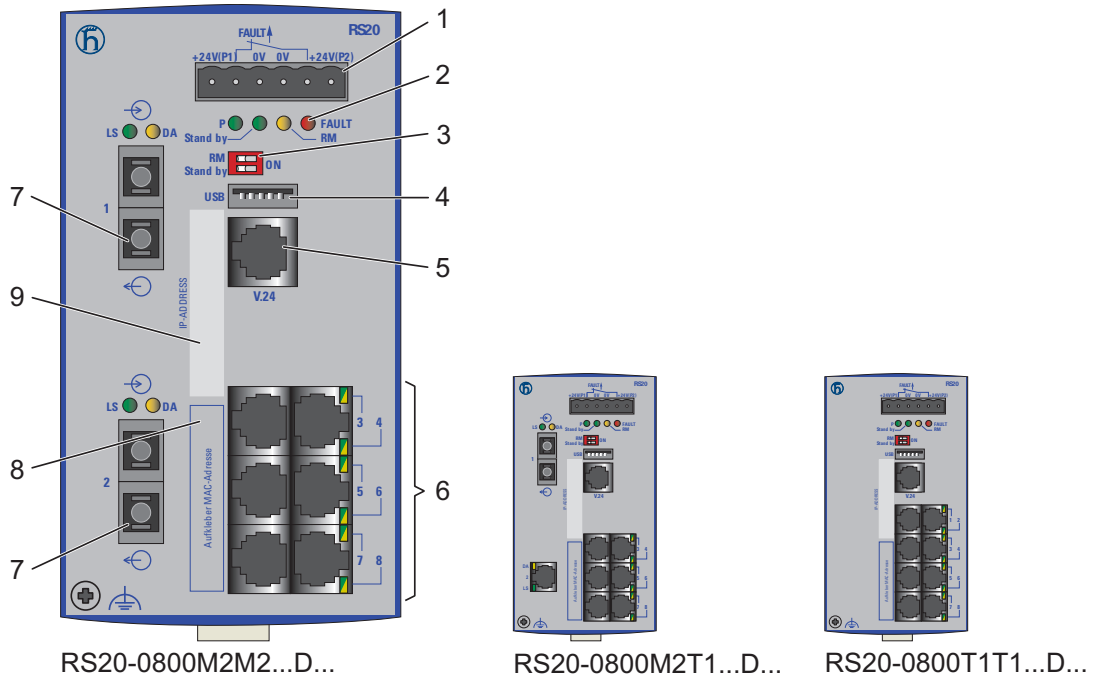

Figure 2: Device variants with 8 * 10/100 Mbit/s ports (RS20-0800...)
1 to 9 – see fig. 1

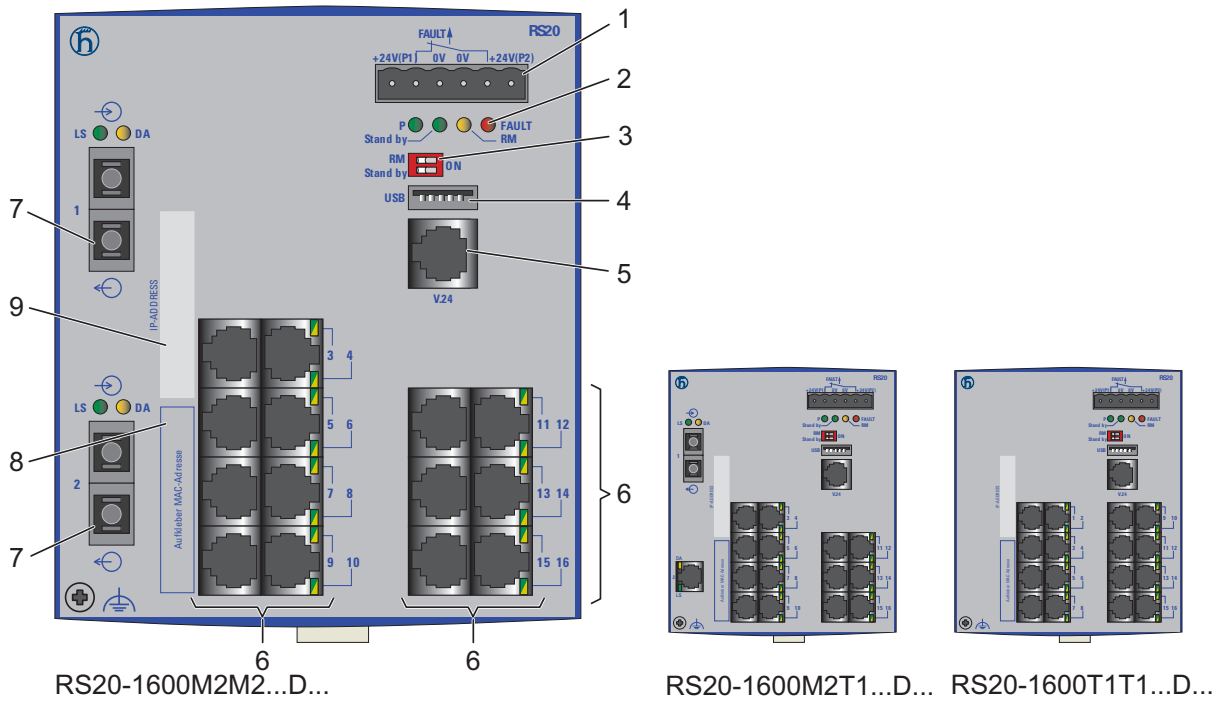

Figure 3: Device variants with 16 * 10/100 Mbit/s ports (RS20-1600...)
1 to 9 – see fig. 1

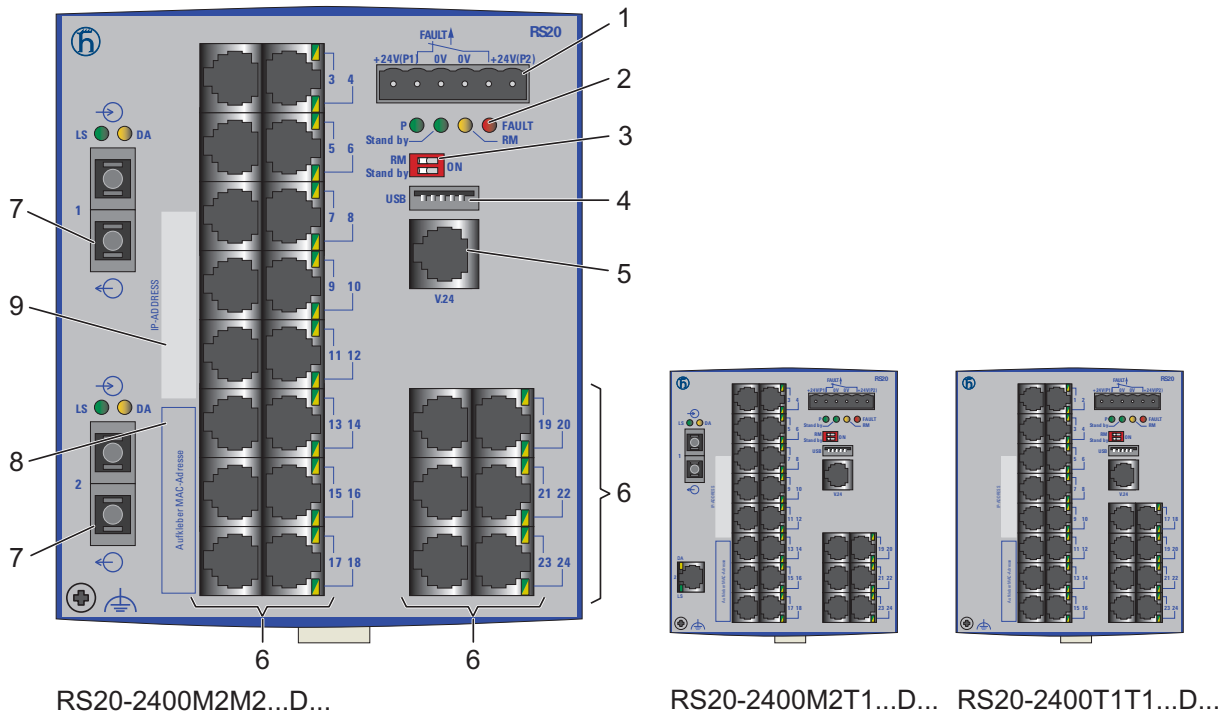

Figure 4: Device variants with 24 * 10/100 Mbit/s ports (RS20-2400...)
1 to 9 – see fig. 1

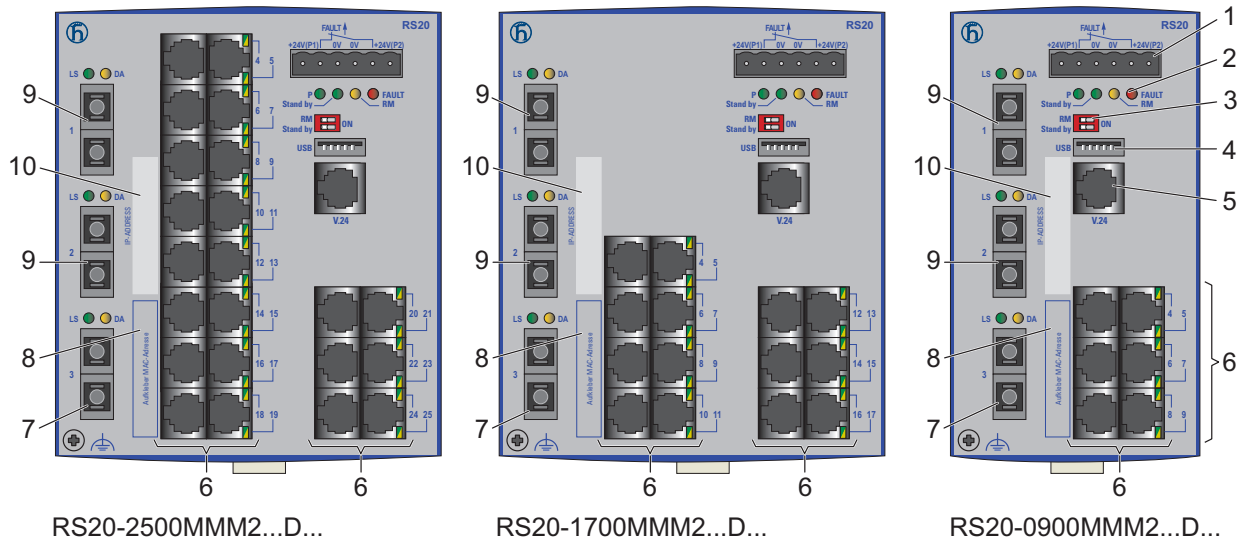

Figure 5: Device variants with 3 uplink ports (100 Mbit/s)
1 to 6 – see fig. 1

7 – port 3, free choice of connection:

T1: Twisted-pair T(X), RJ45, 10/100 Mbit/s

M2: Multimode FX, DSC, 100 Mbit/s

M4: Multimode FX, ST, 100 Mbit/s

S2: Singlemode FX, DSC, 100 Mbit/s

S4: Singlemode FX, ST, 100 Mbit/s

L2: Singlemode Longhaul FX, DSC, 100 Mbit/s

G2: Singlemode Longhaul+ FX, DSC, 100 Mbit/s, 200 km

8 – MAC address field

9 – port 1 + port 2, free choice of connections:

MM: Multimode FX, DSC, 100 Mbit/s

NN: Multimode FX, ST, 100 Mbit/s

VV: Singlemode FX, DSC, 100 Mbit/s

UU: Singlemode FX, ST, 100 Mbit/s

LL: Singlemode Longhaul FX, DSC, 100 Mbit/s

GG: Singlemode Longhaul+ FX, DSC, 100 Mbit/s, 200 km

10 – IP address field

1.1.4 Number of ports and media for RS30-...

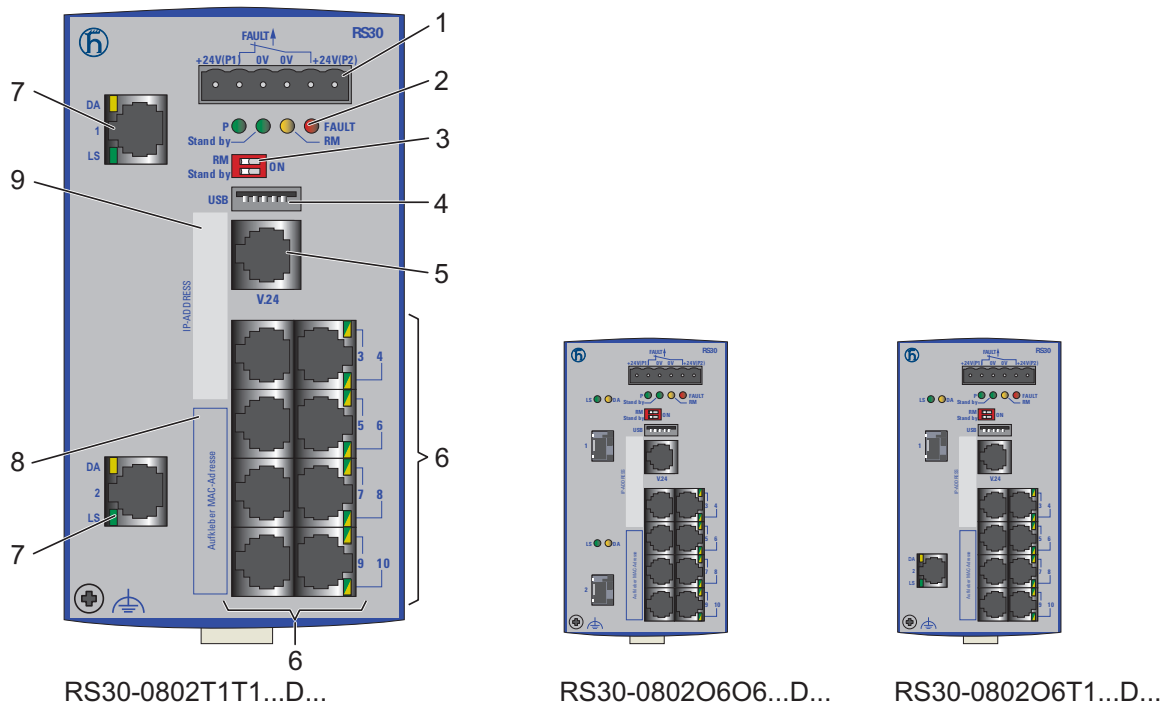

Figure 6: Device variants with 2 * 1000 Mbit/s ports and 8 * 10/100 Mbit/s ports (RS30-0802...)

- 1 – plug-in terminal block, 6-pin
- 2 – LED display elements
- 3 – 2-pin DIP switch
- 4 – USB interface
- 5 – V.24 connection for external management
- 6 – ports in compliance with 10/100BASE-T(X) (RJ45 connections)
- 7 – port 1 + port 2, free choice of connections:
 - T1: Twisted-pair T(X), RJ45, 10/100/1000 Mbit/s
 - O6: SX/LX, SFP slot, 1000 Mbit/s
- 8 – MAC address field
- 9 – IP address field

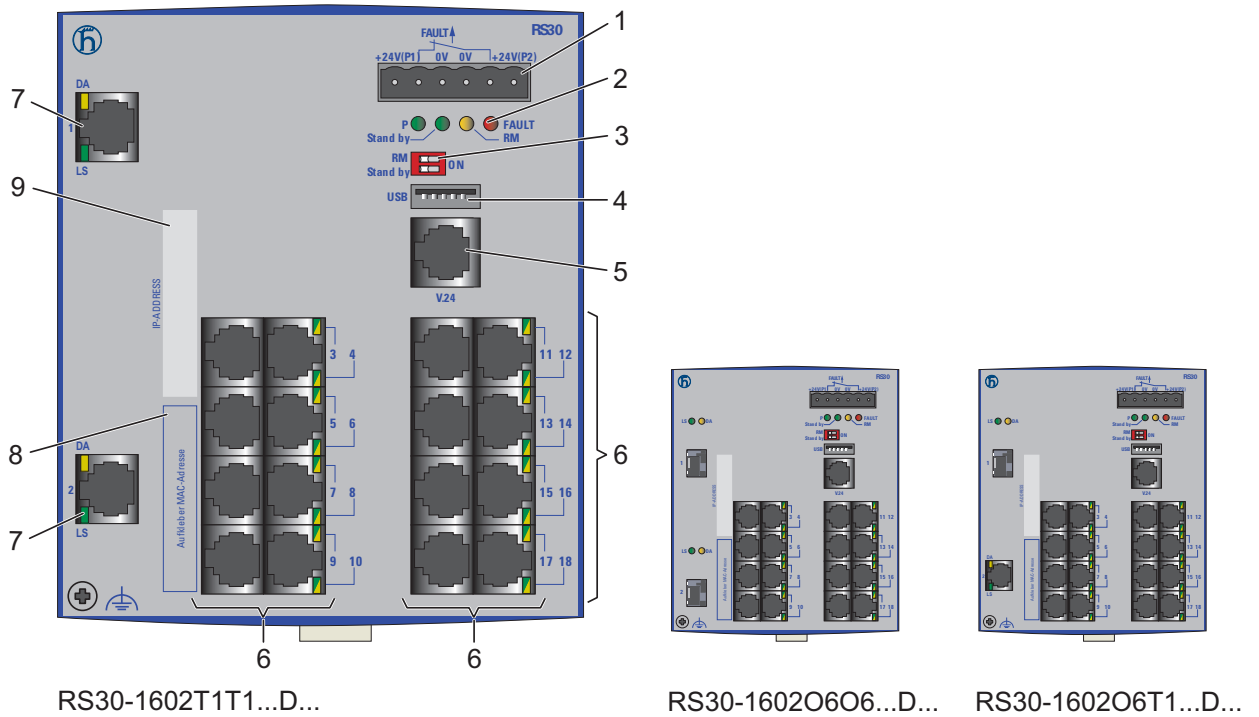

Figure 7: Device variants with 2 * 1000 Mbit/s ports and 16 * 10/100 Mbit/s ports (RS30-1602...)
1 to 9 – see fig. 6

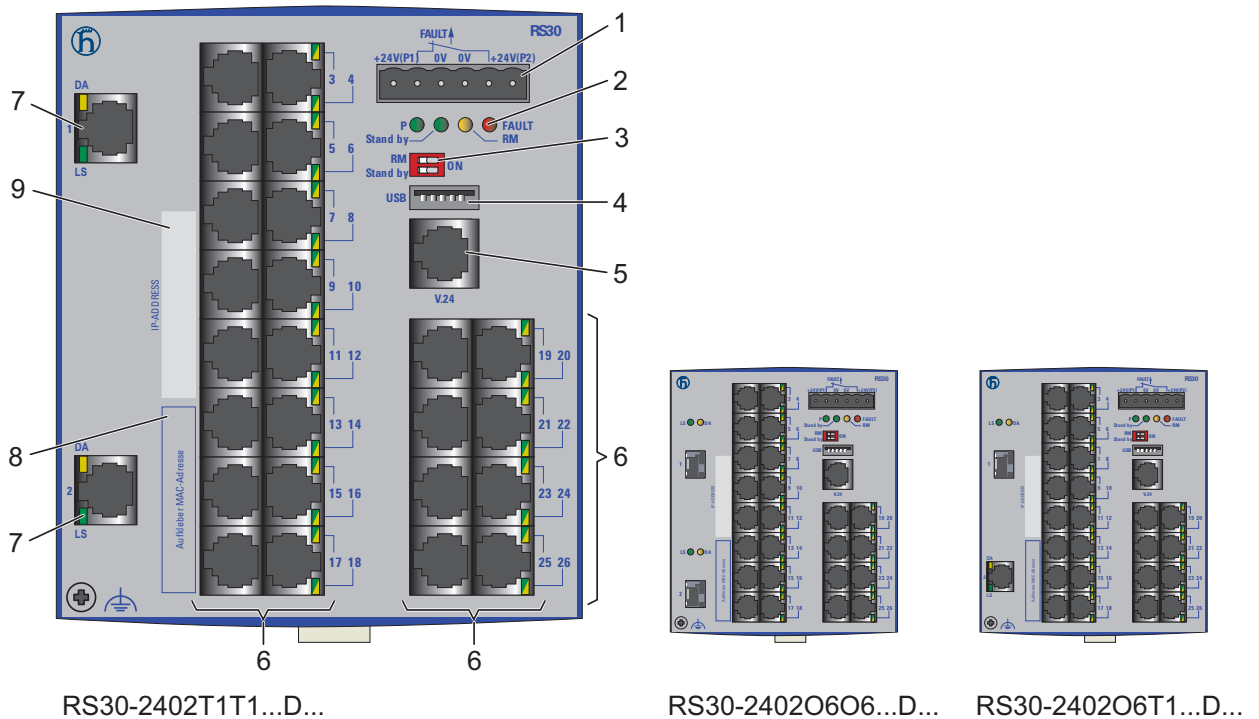

Figure 8: Device variants with 2 * 1000 Mbit/s ports and 24 * 10/100 Mbit/s ports (RS30-2402...)
1 to 9 – see fig. 6

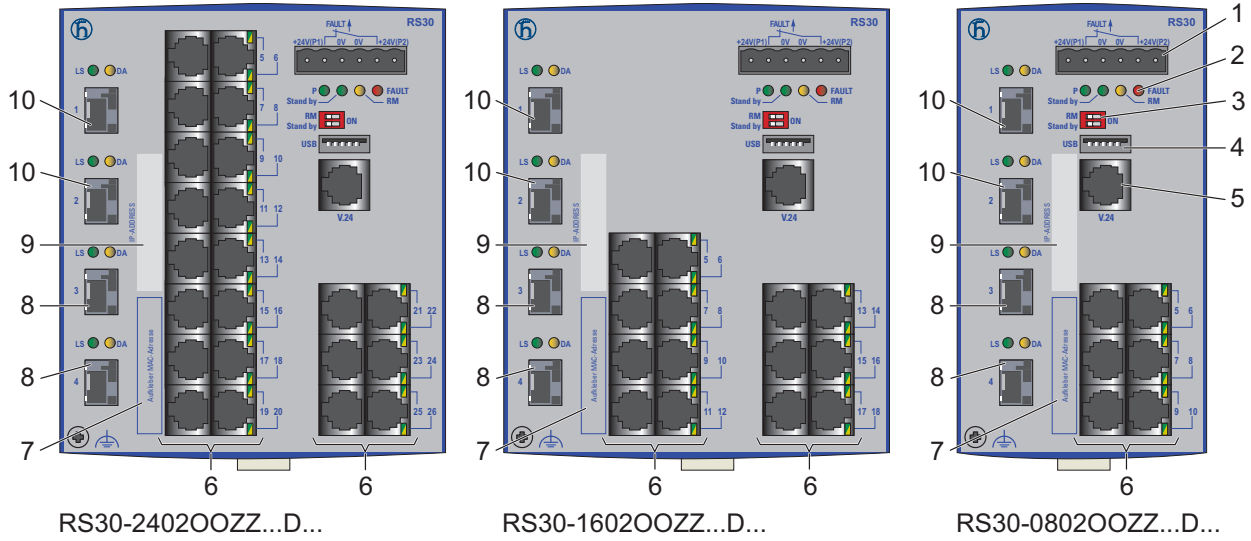

Figure 9: Device variants with 4 uplink ports

1 to 6 – see [fig. 6](#)

7 – MAC address field

8 – port 3 + port 4:

ZZ: FX, SFP slot, 100 Mbit/s

9 – IP address field

10 – port 1 + port 2:

OO: FX/SX/LX, SFP slot, 100/1000 Mbit/s

1.1.5 Number of ports and media for RS40-...

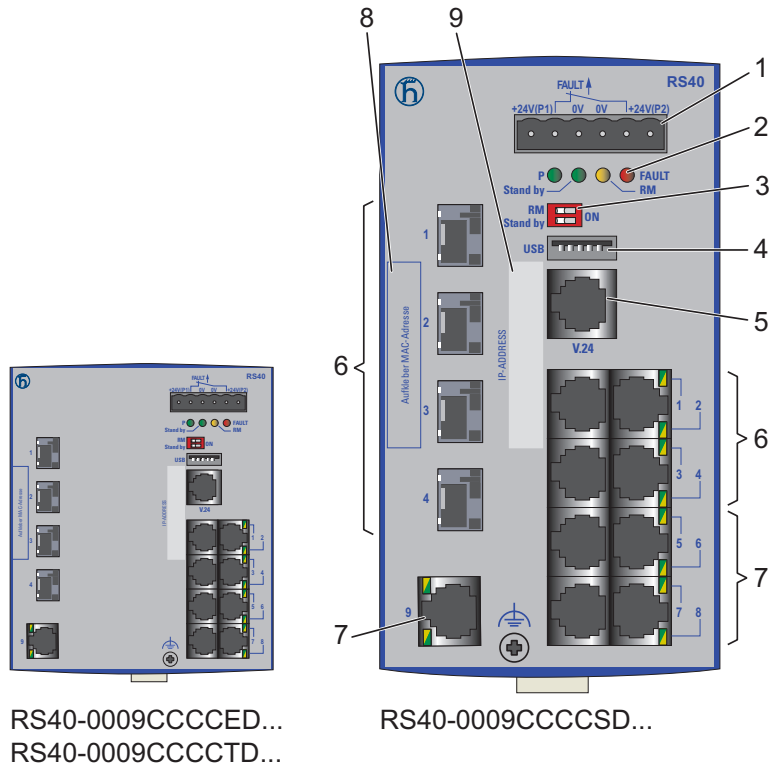

Figure 10: Device variants with 9 * 1000 Mbit/s ports (RS40-0009...)

1 to 5 and 8 to 9 – see [fig. 6](#)

6 – port 1 to port 4: combo ports (CC):

FX/SX/LX, SFP slot, 100 or 1000 Mbit/s

alternatively: T(X), RJ45 connections, 10/100/1000 Mbit/s

7 – ports in compliance with 10/100/1000BASE-T(X) (RJ45 connections)

1.2 Device variants with PoE (optional)

1.2.1 Number of ports and media for devices with PoE

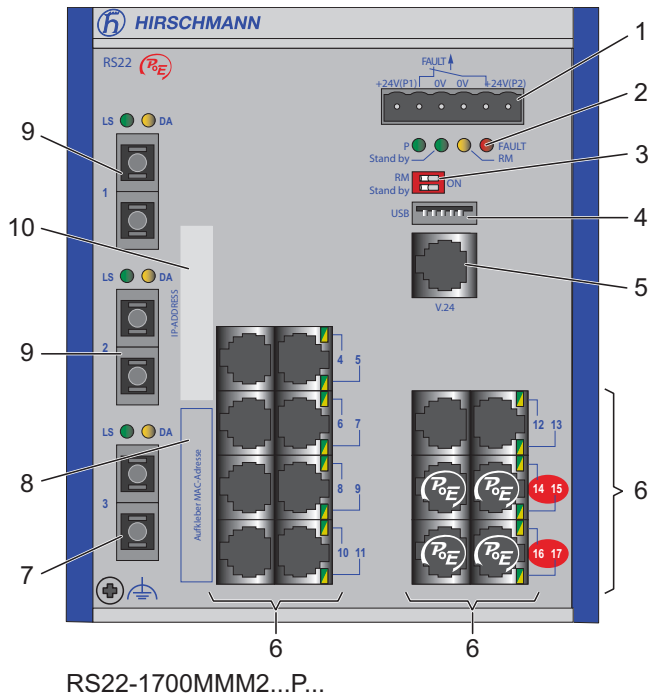

Figure 11: RS22 device variants with PoE (example: RS22-1700MMM2...P...)

1 to 5 and 7 to 9 – see [fig. 5](#)

6 – ports in compliance with 10/100BASE-T(X) (RJ45 connections; the PoE-capable ports 14 to 17 are indicated accordingly)

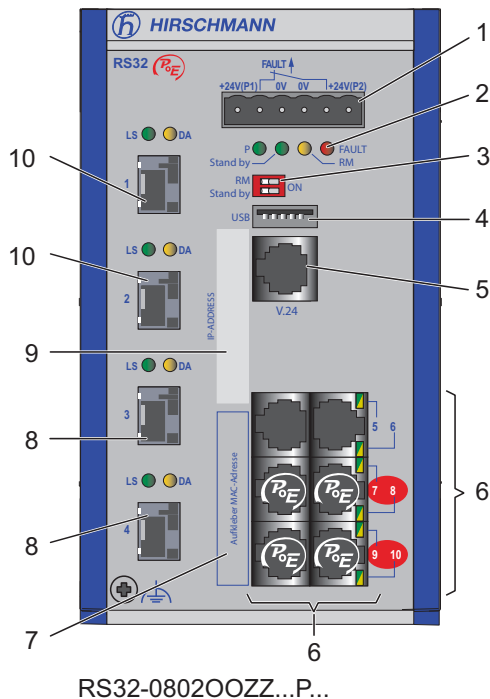

Figure 12: RS32 device variants with 4 uplink ports (example: RS32-08020OZZ...P...)

1 to 5 and 7 to 9 – see [fig. 9](#)

6 – ports in compliance with 10/100BASE-T(X) (RJ45 connections; the PoE-capable ports 7 to 10 are indicated accordingly)

Device variants RS22-... and RS32-... support Power over Ethernet (PoE) in accordance with IEEE 802.3af.

They allow the connection and remote supply of, for example, IP telephones (Voice over IP), webcams, sensors, printer servers and WLAN access points via 10BASE-T/100BASE-TX. With PoE, these terminal devices are powered by the twisted-pair cable.

The RS22-... and RS32-... devices provide four 10BASE-T/100BASE-TX ports (RJ45 sockets) for connecting network segments or PoE terminal devices (PD, Powered Device) for all IEEE802.3af classes up to a maximum power output of 15.4 W.

The 4 PoE-capable ports are the 4 bottom ports on the right side of the device (see on page 28 "Number of ports and media for devices with PoE"). On the device, the PoE ports are highlighted in red.

The current is supplied on wire pairs transmitting the signal; the individual ports are not electrically insulated from each other.

The following conditions are met in accordance with IEEE 802.3af:

- ▶ Endpoint PSE
- ▶ Alternative A

1.2.2 PoE power units

The following PoE power units are available for supplying the devices with PoE voltage:

- ▶ **RPS90/48V LV:** Low-voltage PoE power unit
 - ▶ Input voltage range: 24 V DC to 48 V DC
 - ▶ Power output at up to +60 °C: 90 W
 - ▶ Power output at +60 °C to +70 °C: 60 W
- ▶ **RPS90/48V HV:** High-voltage PoE power unit
 - ▶ Input voltage range:
60 V DC to 250 V DC or 110 V AC to 230 V AC
You can choose between a DC or AC voltage connection.
 - ▶ Power output at up to +60 °C: 90 W
 - ▶ Power output at +60 °C to +70 °C: 60 W

The output voltage can be set in the range from 48 V DC to 54 V DC.
The default setting for the output voltage is 48 V DC.

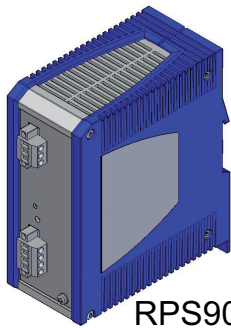

RPS90/48V HV

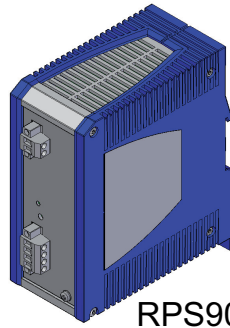

RPS90/48V LV

2 Assembly and start-up

The devices have been developed for practical application in a harsh industrial environment. The installation process is correspondingly simple. On delivery, the device is ready for operation.

The following steps should be performed to install and configure a switch:

- ▶ Unpacking and checking
- ▶ Installing the SFP modules (optional)
- ▶ Insert data in label area
- ▶ Adjust DIP switch settings
- ▶ Connect PoE power unit (optional)
- ▶ Connect the terminal block for voltage supply and signal contact and connect the supply voltage
- ▶ Install the device on the DIN rail, grounding
- ▶ Install the terminal block, start-up procedure
- ▶ Connecting the data lines

2.1 Installing the device

2.1.1 Unpacking and checking

- Check that the contents of the package are complete ([see page 59 "Scope of delivery"](#)).
- Check the individual parts for transport damage.

2.1.2 Installing the SFP modules (optional)

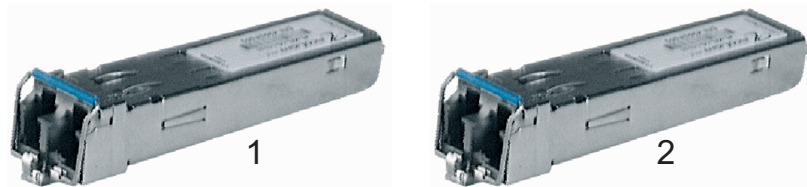

Figure 13: 1 - Fast EETHERNET fiber optic SFP module
2 - Gigabit ETHERNET fiber optic SFP module

- Before attaching an SFP module, first remove the protective cap over the socket.
- Push the SFP module with the lock closed into the socket until it latches audibly in place.

Note: Only use Hirschmann SFP modules ([see page 60 "Accessories"](#)).

2.1.3 Insert data in label area

The information field for the IP address on the front of the device helps you to structure your network installation clearly.

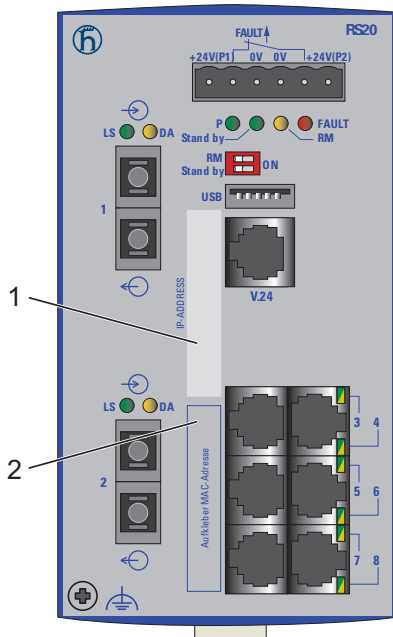

Figure 14: Label area for IP address of device
1 – IP address of device (label area)
2 – MAC address of device (label)

2.1.4 Adjust DIP switch settings

The 2-pin DIP switch on the front panel of the device gives you the following options:



Figure 15: 2-pin DIP switch

Switch RM position	Switch stand-by position	Ring redundancy	Coupling switch	Ring Manager	Coupling Manager	Ring port	Control port	Coupling port	Software configuration
OFF	OFF	on	on	off	off	1 + 2			
ON	OFF	on	on	on	off	1 + 2			
OFF	ON	on	on	off	on	1 + 2	3	4	
ON	ON								SW config. has priority over DIP switch configuration

State on delivery: both DIP switches “ON”.

- Before starting operation of the device, check whether the default settings of the DIP switch correspond to your requirements.

2.1.5 RS20/RS30/RS40: supply voltage and signal contact

The supply voltage and the signal contact are connected via a 6-pin terminal block with a snap lock.



Caution!

Note the safety instructions ([see page 4 "Notes on safety"](#)) and only connect a supply voltage that corresponds to the type plate of your device. Make sure that the contact load capability of the signal contact is not exceeded ([see page 53 "Technical data"](#)).

■ Supply voltage for RS20/RS30/RS40

Redundant power supplies can be used. Both inputs are uncoupled. There is no distributed load. With redundant supply, the power supply unit supplies the device only with the higher output voltage. The supply voltage is electrically isolated from the housing. See “Insulation voltage” in chapter ["Technical data"](#) on [page 53](#).

You can choose between DC or AC voltage when connecting the supply voltage. You use the +24V and 0V pins to connect the AC voltage ([see fig. 16](#)).

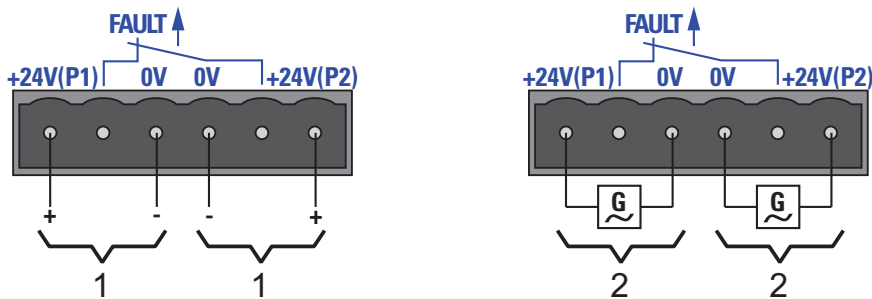

Figure 16: Connecting the supply voltage at the 6-pin terminal block
 1 – DC voltage, voltage range: 9.6 V DC to 60 V DC
 2 – AC voltage, voltage range: 18 V AC to 30 V AC

Note: With non-redundant supply of the main voltage, the device reports a loss of power. You can avert this message by applying the supply voltage via both inputs, or by changing the configuration in the Management.

■ Signal contact for RS20/RS30/RS40

- ▶ The signal contact (“FAULT”, for pin assignment of terminal block, see [fig. 16](#)) monitors the functioning of the device, thus enabling remote diagnostics. You can specify the type of function monitoring in the Management.
- ▶ You can also use the switch Web page to switch the signal contact manually and thus control external devices.

A break in contact is used to report the following conditions via the potential-free signal contact (relay contact, closed circuit):

- ▶ The detected inoperability of at least one of the two voltage supplies (voltage supply 1 or 2 is below the threshold value).
- ▶ A continuous malfunction in the device.
- ▶ The loss of connection at at least one port. The report of the link status can be masked by the Management for each port. In the delivery state, link status monitoring is deactivated.
- ▶ The loss of ring redundancy reserve.
- ▶ A detected error during the self-test.
- ▶ Incorrect configuration of the HIPER-Ring or ring coupling.

The following condition is also reported in RM mode:

- ▶ Ring redundancy reserve is available. On delivery, there is no ring redundancy monitoring.
- Pull the terminal block off the device and connect the power supply and signal lines.

2.1.6 RS22/RS32: supply voltage and signal contact

For the RS22/RS32, the PoE supply voltage and the signal contact are connected via the 6-pin terminal block with a snap lock.

The RS22/RS32 devices are supplied with PoE voltage (48 V DC safety low voltage) via an external power supply unit.

- Make sure that the external power supply unit you use to provide the PoE voltage fulfills the following basic prerequisites:
 - ▶ Insulation requirements according to IEEE 802.3af (insulation resistance 48 V, output to “rest of the world” 2,250 V DC for 1 min.).
 - ▶ Output power < 100 W
 - ▶ Current limitation < 5 A
 - ▶ The power supply unit and the devices with PoE ports form a “limited power source” according to IEC 60950-1.
 - ▶ The external PoE power supply unit must be able to provide the power for the connected PDs (Power Devices) and for the Switch.

Note: The RS22/RS32 devices fulfill the technical data and the certifications when using the RPS90/48V LV and RPS90/48V HV power units from Hirschmann. Only use these power units, to ensure that the specifications are fulfilled.

■ RPS90/48V LV: connecting the input voltage

With the RPS90/48V LV low-voltage PoE power unit, you connect a DC supply voltage of 24 V DC to 48 V DC at the input connection.

The supply voltage is connected via pin 1 and pin 2.

Figure	Pin	Assignment	Voltage range
	1	Minus terminal of the supply voltage	Low voltage input voltage: 24 V DC to 48 V DC
	2	Plus terminal of the supply voltage	

Table 7: Connecting the low-voltage supply voltage at PoE power unit RPS90/48V LV

- First connect the protective conductor to the protective conductor terminal.
- Connect the DC voltage to the 2-pin terminal block.
- Use a supply cable with a maximum length of 2 meters to the power unit.

■ RPS90/48V HV: connecting the input voltage

With the RPS90/48V HV high-voltage PoE power unit, you connect either a DC or AC supply voltage at the input connection:

- ▶ 60 V DC to 250 V DC
- ▶ 110 V AC to 230 V AC

The supply voltage is connected via pin 2 and pin 3, and the protective conductor is connected via pin 1.

Figure	Pin	Assignment	Voltage range
	1	Protective conductor	High voltage input voltage: 110 V AC to 230 V AC
	2	Minus terminal of the supply voltage	
	3	Plus terminal of the supply voltage	

Table 8: Connecting the high-voltage supply voltage at PoE power unit RPS90/48V HV (AC voltage)

Figure	Pin	Assignment	Voltage range
	1	Protective conductor	High-voltage input voltage: 60 V DC to 250 V DC
	2	Minus terminal of the supply voltage	
	3	Plus terminal of the supply voltage	
		= external fuse for supply voltages > 125 V DC	

Table 9: Connecting the high-voltage supply voltage at PoE power unit RPS90/48V HV (DC voltage)

- First connect the protective conductor to the protective conductor terminal.
- Connect the supply voltage via the 3-pin terminal block. Pay attention to the +/L and -/N connections.
- If the neutral conductor or the minus terminal of the supply voltage is not grounded, install a suitable fuse in the input line.
- For supply voltages > 125 VDC:
Install a suitable external fuse in the supply voltage input line of the plus terminal.
- Use a supply cable with a maximum length of 2 meters to the power unit.

■ RS22/RS32 supply voltage

The RPS90/48V LV and RPS90/48V HV PoE power supply units provide an output voltage of typically 48 V DC for supplying the RS22-.../RS32-... devices with the PoE voltage.



Caution!

Note the safety instructions (see page 4 "Notes on safety") and only connect a supply voltage that corresponds to the type plate of your device. Make sure that the contact load capability of the signal contact is not exceeded (see page 53 "Technical data").

Figure	Pin	Assignment	Voltage range
	1+2	Minus terminal of the output voltage	Output voltage (PoE voltage) range: 48 V DC to 54 V DC (default: 48 V DC)
	3+4	Plus terminal of the output voltage	

Table 10: Output voltage of RPS90/48V LV and RPS90/48V HV PoE power units

- Connect the PoE voltage to the 6-pin terminal block for the device included in the delivery.
Make sure the following requirements are met:
 - ▶ Supply line length < 0.5 m.

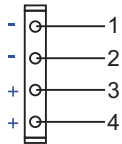
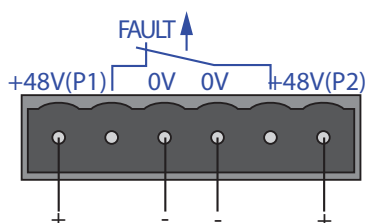

Figure 17: Connecting the PoE supply voltage at the 6-pin terminal block of device RS22/RS32

■ RS22/RS32 signal contact

- ▶ The signal contact (“FAULT”, for pin assignment of terminal block, see [fig. 17](#)) monitors the functioning of the device, thus enabling remote diagnostics. You can specify the type of function monitoring in the Management.
- ▶ You can also use the switch Web page to switch the signal contact manually and thus control external devices.

A break in contact is used to report the following conditions via the potential-free signal contact (relay contact, closed circuit):

- ▶ The detected inoperability of at least one of the two voltage supplies (voltage supply 1 or 2 is below the threshold value).
- ▶ A continuous malfunction in the device.
- ▶ The loss of connection at at least one port. The report of the link status can be masked by the Management for each port. In the delivery state, link status monitoring is deactivated.
- ▶ The loss of ring redundancy reserve.
- ▶ A detected error during the self-test.
- ▶ Incorrect configuration of the HIPER-Ring or ring coupling.

The following condition is also reported in RM mode:

- ▶ Ring redundancy reserve is available. On delivery, there is no ring redundancy monitoring.

- Pull the terminal block off the device and connect the power supply and signal lines.

2.1.7 Installing the device on the DIN rail, grounding

■ Mounting on the DIN rail

The devices are mounted very quickly by snapping them onto the DIN rail.

- Mount the device on a 35 mm DIN rail in accordance with DIN EN 60175.
- Attach the upper snap-in guide of the device into the DIN rail and press it down against the DIN rail until it snaps into place.

Note: The shielding ground of the connectable twisted pair lines is connected to the front panel as a conductor.

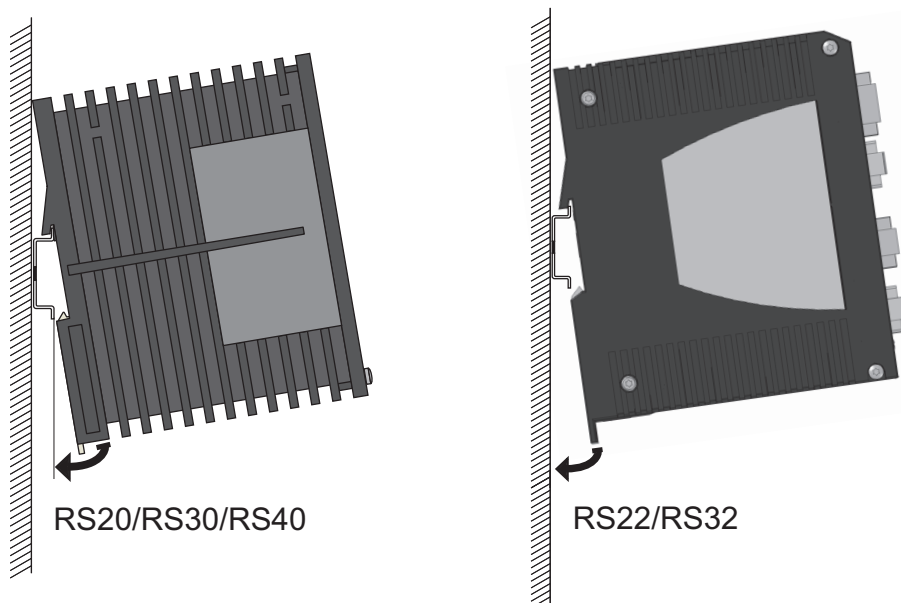

Figure 18: Mounting on the DIN rail

■ DIN rail mounting on ships (RS30-0802...)

When you are mounting your RS30-0802... Open Rail device on a DIN rail on ships and in similar applications, the Open Rail Mounting Kit available as an accessory can be used to avoid excessive resonance.

- You must use the Open Rail Mounting Kit with the order number 942 007-001 (see page 60 "Accessories") when mounting your RS30-0802... device on ships.

If you have very little space on your DIN rail, you can alternatively use Open Rail Mounting Kit 942 007-101 (for mounting DIN rail on DIN rail).

- Mount one mounting kit on each side of your RS30-0802... device, but at least one mounting kit on one side of the RS30-0802... device. If possible, position one side of the RS30-0802... device on a wall, or in a similarly stable way. If you are positioning multiple RS30-0802... devices side by side, mount the row of devices in the way described for a single device.
- Mount a standard DIN rail stopper on both sides beside the mounting kit.

For more information on mounting the RS30-0802... on a DIN rail on ships, see the “Open Rail Mounting Kit Mounting Instructions” manual supplied with the Open Rail Mounting Kit.

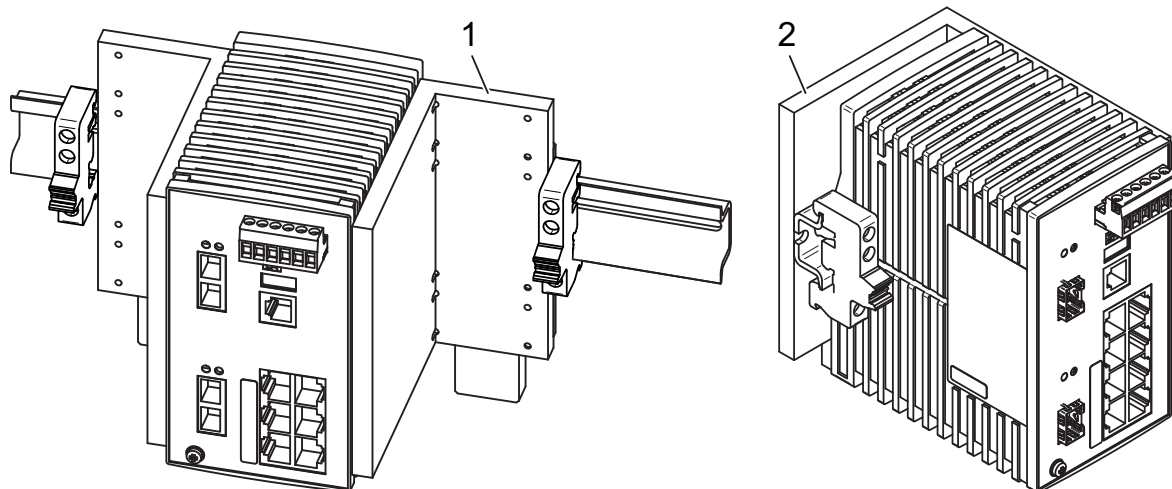

Figure 19: Mounting the RS30-0802... on ships with the Open Rail Mounting Kit
 1 - Open Rail Mounting Kit 942 007-001
 2 - Open Rail Mounting Kit 942 007-101

■ **Mounting on the wall (RS22/RS32)**

In addition to the option of mounting them on a DIN rail, you can also mount the RS22/RS32 devices on the wall using the wall mounting plate supplied ([see page 60 "Accessories"](#)).



Figure 20: Mounting the RS22/RS32 devices on the wall

- Mount the device on the wall plate as shown in the illustration. Insert the upper snap-in guide of the device into the rail and press it down against the rail until it snaps into place.
- Fasten the wall plate ([see on page 60 "Accessories"](#)) on a level wall surface using four screws.

■ Grounding

With the RS20/RS30/RS40, the front panel of the device is grounded via the separate ground screw.

With the RS22/RS32, the front panel and the metal housing of the device is grounded via the separate ground screw.

- For the ground conductor, use a cable with a cross section of at least 1.0 mm².

2.1.8 Dimension drawings

■ Dimension drawings for RS20/RS30/RS40

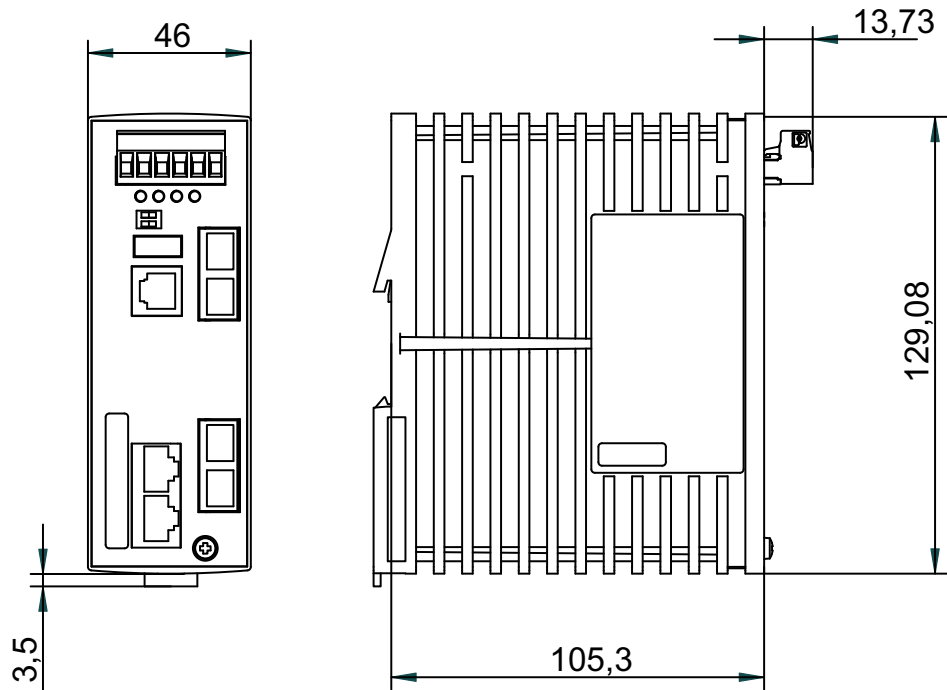

Figure 21: Dimensions of device variants RS20-04... with 4 ports

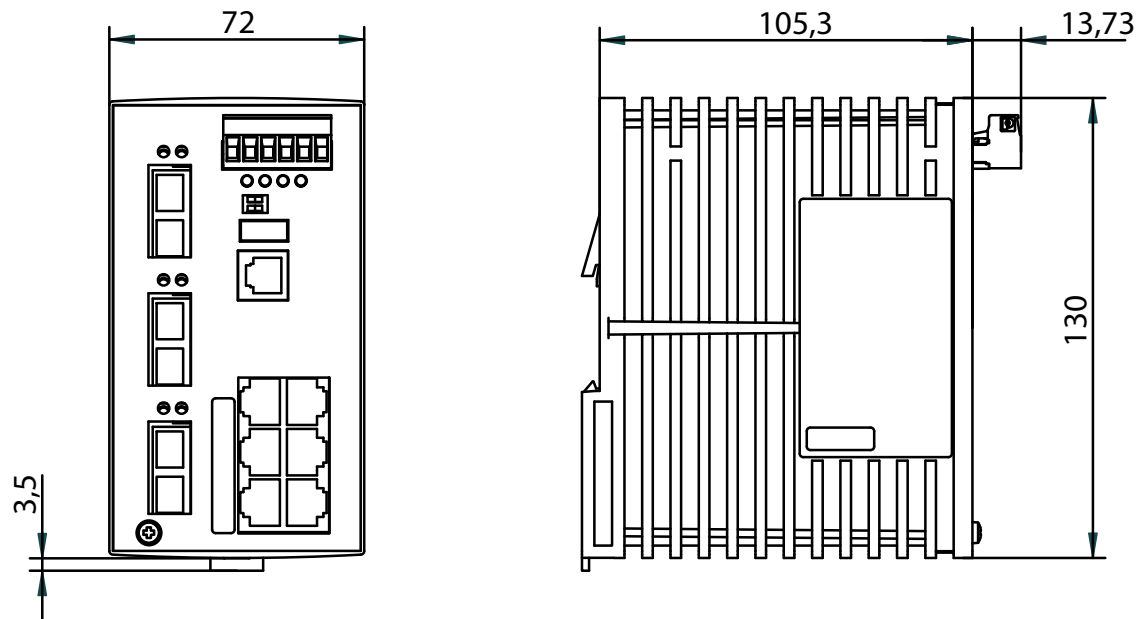

Figure 22: Dimensions of device variants RS20.../RS30.../RS40... with 8 to max. 10 ports

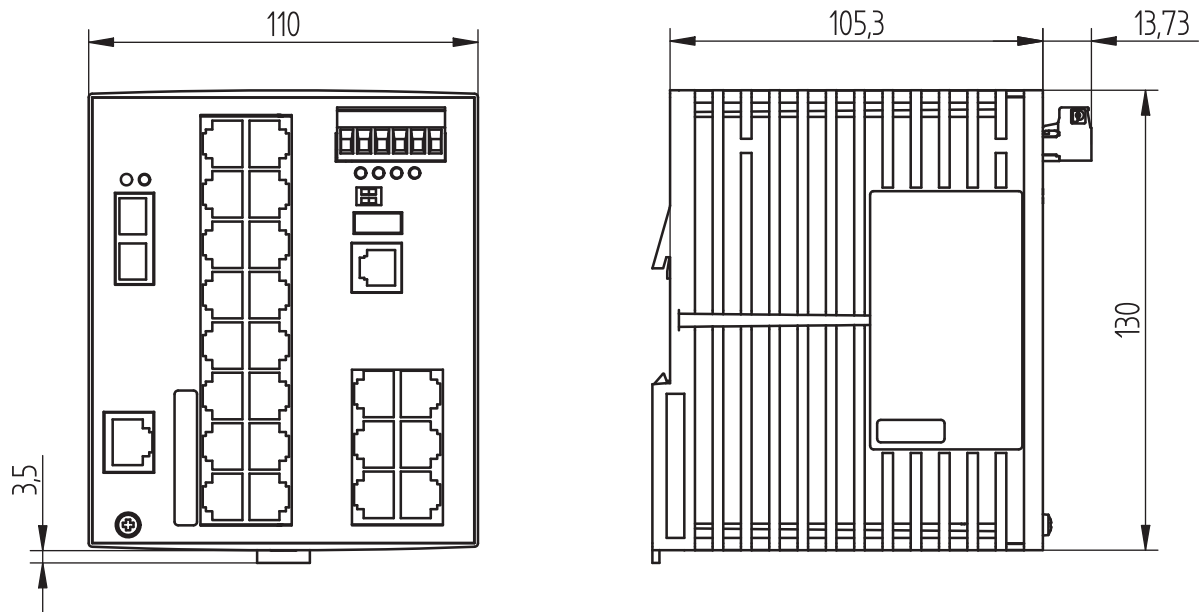

Figure 23: Dimensions of device variants RS20.../RS30.../RS40... with 16 to max. 26 ports

■ Dimension drawings for RS22/RS32

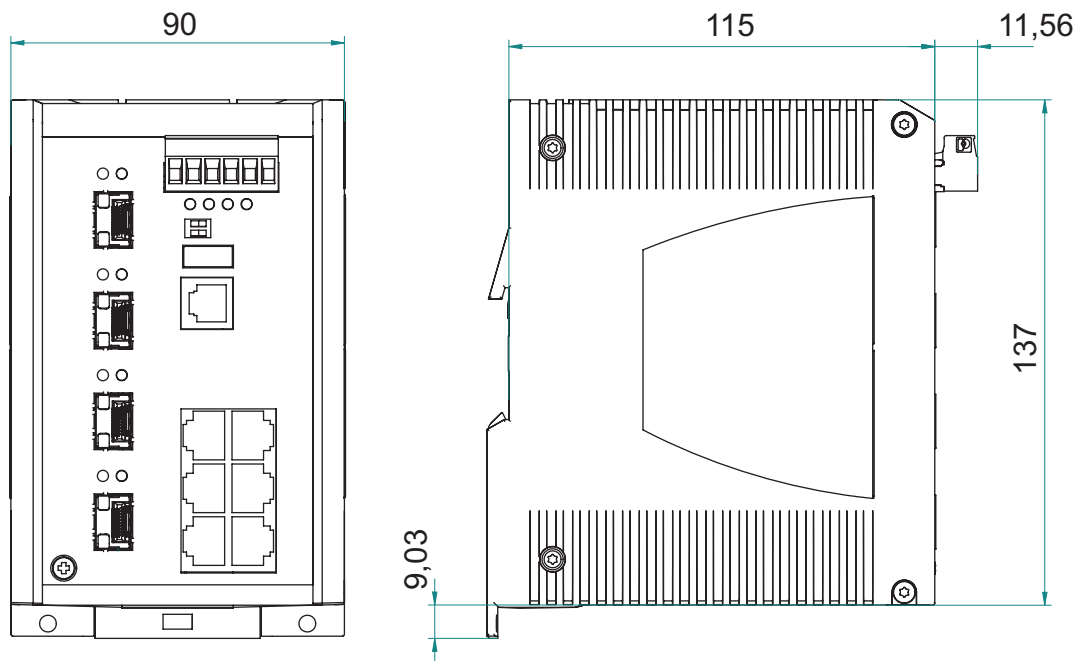

Figure 24: Dimensions of device variants RS22.../RS32... with 8 to max. 10 ports

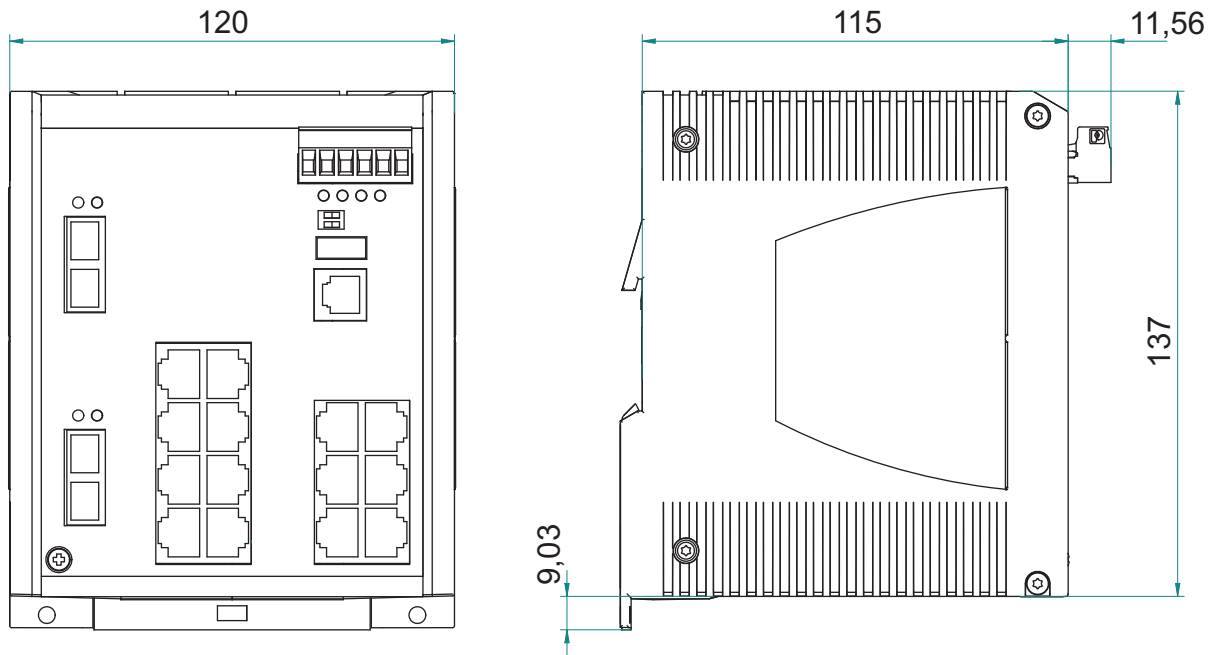

Figure 25: Dimensions of device variants RS22.../RS32... with 16 to max. 26 ports

■ **Dimension drawings for PoE power units**

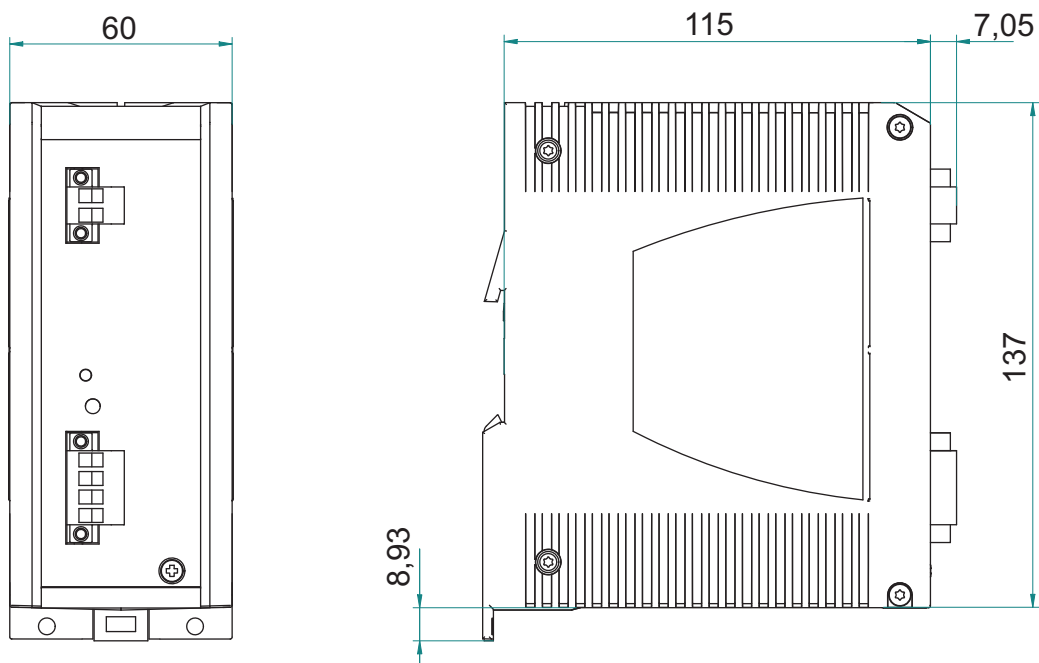

Figure 26: Dimensions of RPS90/48V LV and RPS90/48V HV PoE power units

2.1.9 Connecting the ferrite

Note: For PoE devices with 16 or more ports (RS22-16..., RS22-17..., RS22-24... and RS22-25...):

To adhere to EMC conformity, you connect the ferrite supplied to the 48V output of the voltage supply line (see fig. 27).

- Insert both cables of the 48V output through the ferrite twice.
- Lock the ferrite.
- The ferrite should be connected as close as possible to the output (max. distance 50 cm).

The ferrite can be opened with the key supplied.

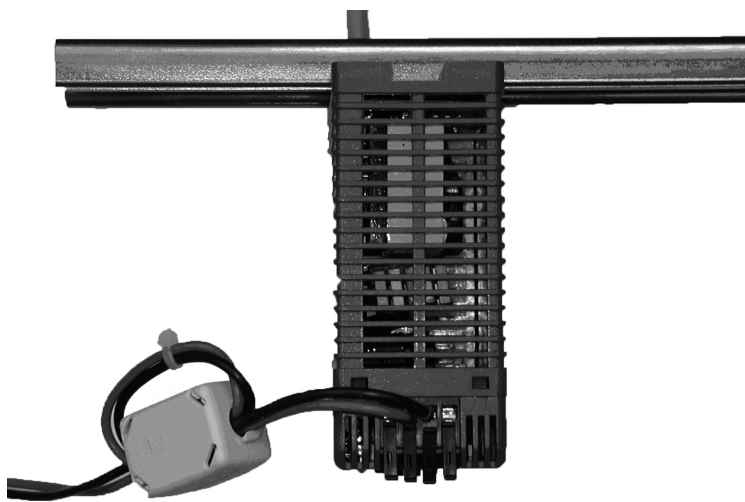

Figure 27: Connecting the ferrite to the voltage supply line

2.1.10 Installing the terminal block, start-up procedure

- Mount the terminal block for the voltage supply and signal contact on the front of the device using the snap lock. Make sure that the snap lock snaps into place.

Connecting the voltage supply via the terminal block starts the operation of the device.

2.1.11 Connecting the data lines

You can connect terminal devices and other segments at the ports of the device via twisted pair cables or F/O cables.

- Install the data lines according to your requirements.

■ 10/100 Mbit/s twisted pair connection

These connections are RJ45 sockets.

10/100 Mbit/s TP ports enable the connection of terminal devices or independent network segments according to the IEEE 802.3 10BASE-T/100BASE-TX standard.

These ports support:

- ▶ Autonegotiation
- ▶ Autopolarity
- ▶ Autocrossing (if autonegotiation is activated)
- ▶ 100 Mbit/s half-duplex mode, 100 Mbit/s full duplex mode
- ▶ 10 Mbit/s half-duplex mode, 10 Mbit/s full duplex mode

State on delivery: autonegotiation activated.

The socket housing is electrically connected to the front panel.

Figure	Pin	Function
	1+2	One line pair: receiver path
	3+6	One line pair: sender path
	4,5,7,8	Not used

Table 11: Pin assignment of a TP/TX interface in MDI-X mode, RJ45 socket

■ 10/100 Mbit/s twisted-pair connection PoE (RS22-.../RS32-...)

These connections are RJ45 sockets.

10/100 Mbit/s TP PoE ports enable the connection of terminal devices or independent network segments according to the IEEE 802.3 10BASE-T/100BASE-TX and IEEE 802.3af (Power over ETHERNET on data lines) standards.

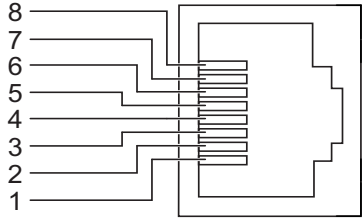
These ports support:

- ▶ Autonegotiation
- ▶ Autopolarity
- ▶ Autocrossing (if autonegotiation is activated)
- ▶ 100 Mbit/s half-duplex mode, 100 Mbit/s full duplex mode
- ▶ 10 Mbit/s half-duplex mode, 10 Mbit/s full duplex mode
- ▶ Power over ETHERNET (PoE, at the last four ports of the device)

State on delivery: autonegotiation activated.

The socket housing is electrically connected to the front panel.

The PoE voltage is input via the wire pairs transmitting the signal (phantom voltage).

Figure	Pin	Function	PoE
	1	RD+ Receive Data +	V-
	2	RD- Receive Data -	V-
	3	TD+ Transmit Data +	V+
	6	TD- Transmit Data -	V+
	4,5,7,8	Not used	

Table 12: Pin assignment of a TP/TX interface for PoE for the voltage supply to the wire pairs transmitting the signal, RJ45 socket, MDI-X mode

■ 10/100/1000 Mbit/s twisted pair connection

These connections are RJ45 sockets.

10/100/1000 Mbit/s TP ports enable the connection of terminal devices or independent network segments according to the IEEE 802.3 10BASE-T/100BASE-TX/1000BASE-T standard.

These ports support:

- ▶ Autonegotiation
- ▶ Autopolarity
- ▶ Autocrossing (if autonegotiation is activated)
- ▶ 1000 Mbit/s full duplex
- ▶ 100 Mbit/s half-duplex mode, 100 Mbit/s full duplex mode
- ▶ 10 Mbit/s half-duplex mode, 10 Mbit/s full duplex mode

State on delivery: autonegotiation activated.

The socket housing is electrically connected to the front panel.

The pin assignment corresponds to MDI-X.

Figure	Pin	Function
	1	BI_DB +
	2	BI_DB -
	3	BI_DA +
	4	BI_DD +
	5	BI_DD -
	6	BI_DA -
	7	BI_DC +
	8	BI_DC -

Table 13: Pin assignment of a 1000 MBit/s TP interface in MDI-X mode, RJ45 socket

■ **100 Mbit/s F/O connection**

In device variants RS20 and RS22, these ports are DSC connectors or ST connectors.

In device variants RS30, RS32 and RS40, these ports are SFP slots. 100 MBit/s F/O ports enable the connection of terminal devices or independent network segments in compliance with the IEEE 802.3 100BASE-FX standard.

These ports support:

- ▶ Full or half duplex mode

State on delivery: full duplex FDX

Note: Make sure that the LH ports are only connected with LH ports, SM ports are only connected with SM ports, and MM ports only with MM ports.

■ **1 Gbit/s F/O connection**

These ports are SFP slots.

1 Gbit/s F/O ports enable the connection of terminal devices or independent network segments according to the IEEE 802.3 1000BASE-SX/1000BASE-LX standard.

These ports support:

- ▶ Autonegotiation

Note: Make sure that the LH ports are only connected with LH ports, SX ports are only connected with SX ports, and LX ports only with LX ports.

Note: In device variants RS30-...02OOZZ... and RS32-...02OOZZ... (four uplink ports with SFP slot) Gigabit-ETHERNET-SFP transceivers or Fast-ETHERNET-SFP transceivers can be mounted at the two top ports, and Fast-ETHERNET-SFP transceivers can be mounted at the two bottom ports ([see page 60 "Accessories"](#)).

In device variants RS40-... Gigabit-ETHERNET-SFP transceiver or Fast-ETHERNET-SFP transceiver can be mounted at the combo ports ([see page 60 "Accessories"](#)).

2.2 Display elements

After the operating voltage is set up, the software starts and initializes itself. Afterwards, the device performs a self-test. During this process, various LEDs light up. The process takes around 60 seconds.

■ Device state

These LEDs provide information about conditions which affect the operation of the whole device.



Figure 28: Device status LEDs

P - Power (green/yellow LED)	
Glowing green	Both supply voltages are on
Glowing yellow	There is only one supply voltage (P1 or P2) on
Not glowing	Supply voltages P1 and P2 are too low
FAULT - error, signal contact (red LED) ^a	
Glowing red	The signal contact is open, i.e. it is reporting an error.
Not glowing	The signal contact is closed, i.e. it is not reporting an error.
RM - Ring Manager (green/yellow LED)	
Glowing green	RM function active, redundant port disabled
Glowing yellow	RM function active, redundant port enabled
Not glowing	RM function not active
Flashing green	Incorrect configuration of the HIPER-Ring (e.g. the ring is not connected to the ring port).
Stand-by	
Glowing green	Stand-by mode enabled
Not glowing	Stand-by mode not enabled
RM and Stand-by - display saving processes of the AutoConfiguration Adapter (ACA)	
Flashing alternately	Error during saving process.
LEDs flash synchronously, two times a second	Loading configuration from the ACA.
LEDs flash synchronously, once a second	Saving the configuration in the ACA.

■ Port state

The green and yellow LEDs at the individual port display port-related information. During the boot phase, these LEDs are used to display the status of the boot procedure.

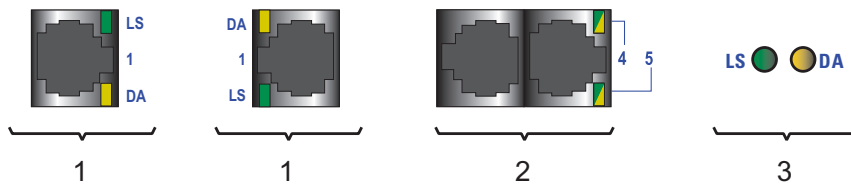

Figure 29: Port status LEDs

1 – Port status LEDs for isolated or single-row RJ45 sockets: one green and one yellow LED per port.

2 – Port status LEDs for double-row RJ45 sockets: one LED per port, glowing/flashing either green or yellow.

3 – Port status LEDs for DSC, ST, SFP

LS - link status (green LED)

Not glowing	No valid connection.
Glowing green	Valid connection.
Flashing green (1 time a period)	Port is switched to stand-by.
Flashing green (3 times a period)	Port is switched off.

DA - data (yellow LED)

Not glowing	No data reception at corresponding port
Flashing yellow	Data reception at corresponding port

2.3 Basic set-up

The IP parameters must be entered when the device is installed for the first time. The device provides the following options for configuring IP addresses:

- ▶ Configuration via V.24 connection
- ▶ Configuration using the HiDiscovery protocol
- ▶ Configuration via BOOTP
- ▶ Configuration via DHCP
- ▶ Configuration via DHCP Option 82
- ▶ Configuration using AutoConfiguration Adapter

Further information on the basic settings of the device can be found in the "Basic Configuration" user manual on the CD ROM.

■ Default settings

- ▶ IP address: The device looks for the IP address using DHCP
- ▶ Password for management:
 - Login: user; password: public (read only)
 - Login: admin; password: private (read and write)
- ▶ V.24 data rate: 9,600 Baud
- ▶ Ring redundancy: disabled
- ▶ Ethernet ports: link status is not evaluated (signal contact)
- ▶ Optical 100 Mbit/s ports: 100 Mbit/s, full duplex
- ▶ All other ports: autonegotiation
- ▶ Ring Manager disabled (DIP switch RM and stand-by: ON)
- ▶ Stand-by coupling disabled (DIP switch RM and stand-by: ON)
 - Port 4 = control port, port 3 = coupling port for red. Ring coupling
- ▶ Rapid Spanning Tree enabled

■ USB interface

The USB socket has an interface for the local connection of an AutoConfiguration Adapter ACA 21-USB. It is used for saving/loading the configuration data and diagnostic information, and for loading the software.

Figure	Pin	Function
	1	VCC (VBus)
	2	- Data
	3	+ Data
	4	Ground (GND)

Table 14: Pin assignment of the USB interface

■ V.24 interface (external management)

The V.24 interface is an RJ11 socket.

At the V.24 connection, a serial interface is provided for the local connection of an external management station (VT100 terminal or PC with corresponding terminal emulation) or an AutoConfiguration Adapter ACA 11. This enables you to set up a connection to the Command Line Interface (CLI) and to the system monitor.

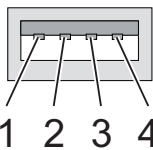
VT 100 terminal settings

Speed	9,600 Baud
Data	8 bit
Stopbit	1 bit
Handshake	off
Parity	none

The socket housing is electrically connected to the front panel of the device.

The V.24 interface is not electrically isolated from the supply voltage.

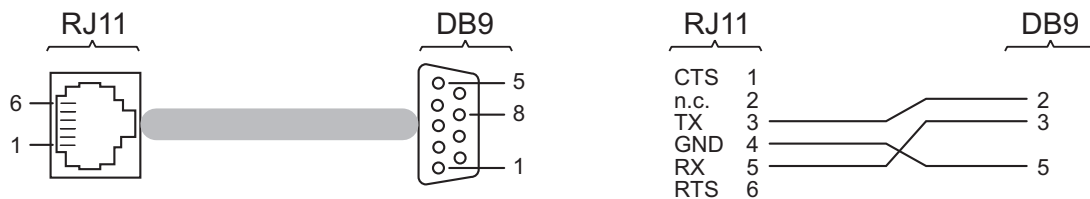

Figure 30: Pin assignment of the V.24 interface and the DB9 connector

Note: You will find the order number for the terminal cable, which is ordered separately, in the Technical Data chapter ([see page 60](#)).

You will find a description of the V.24 interface in the “Basic Configuration User Manual” on the CD-ROM.

2.4 Disassembly

■ Removing the device from the DIN rail

- To take the device off the DIN rail, insert a screwdriver horizontally under the housing into the locking slide, pull it (without tipping the screwdriver) downwards and lift the device upwards.

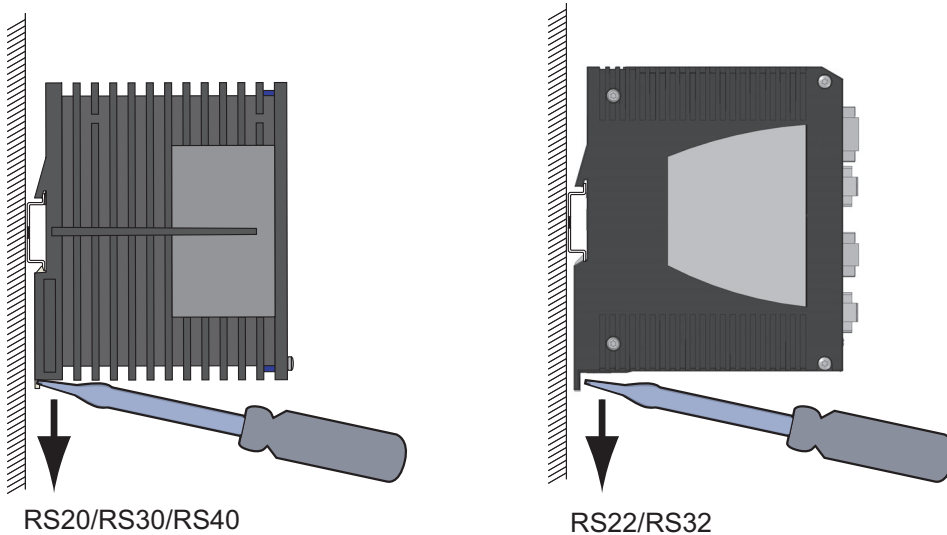

■ Removing the device from the wall mounting plate

- To remove the device from the rail of the wall plate, press the device downwards and pull it from the rail below.

■ Disassembling the SFP modules

- Pull the module out of the socket by means of the opened lock.
- Close the module with the protective cap.



3 Technical data

■ General technical data

Dimensions W x H x D	RS20-0400...	47 mm x 131 mm x 111 mm
	RS20-08..., RS20-09..., RS30-0802	74 mm x 131 mm x 111 mm
	RS20-16..., RS20-17..., RS30-1602	110 mm x 131 mm x 111 mm
	RS20-24..., RS20-25..., RS30-2402	110 mm x 131 mm x 111 mm
	RS40-0009CCCCS...	74 mm x 131 mm x 111 mm
	RS40-0009CCCCE..., RS40-0009CCCCT...	110 mm x 131 mm x 111 mm
	RS22-08..., RS22-09..., RS32-0802	90 mm x 137 mm x 115 mm
	RS22-16..., RS22-17..., RS32-1602	120 mm x 137 mm x 115 mm
	RS22-24..., RS22-25..., RS32-2402	120 mm x 137 mm x 115 mm
	RPS 90/48V LV PoE power unit	60 mm x 137 mm x 115 mm
RPS 90/48V HV PoE power unit	60 mm x 137 mm x 115 mm	
Weight	RS20-0400...	400 g
	RS20-08..., RS20-09..., RS30-0802	410 g
	RS20-16..., RS20-17..., RS30-1602	600 g
	RS20-24..., RS20-25..., RS30-2402	650 g
	RS40-0009CCCCS...	530 g
	RS40-0009CCCCE..., RS40-0009CCCCT...	600 g
	RS22-08..., RS22-09..., RS32-0802	820 g
	RS22-16..., RS22-17..., RS32-1602	1150 g
	RS22-24..., RS22-25..., RS32-2402	1200 g
	RPS 90/48V LV PoE power unit	770 g
RPS 90/48V HV PoE power unit	740 g	
Power supply	Operating voltage RS20-..., RS30-..., RS40-...	12 to 48 V DC
	Rated voltage range DC	min. 9.6 to max. 60 V DC
	Max. voltage range DC	24 V AC
	Rated voltage range AC	min. 18 to max. 30 V AC
	Max. voltage range AC	Safety extra-low voltage (SELV), redundant inputs disconnected. Relevant for North America: NEC Class 2 power source max. 5A.
	Operating voltage RS22-..., RS32-...	48 V (47 V DC to 52 V DC)
		Safety extra-low voltage (SELV), redundant inputs disconnected. Relevant for North America: NEC Class 2 power source max. 5A.

PoE power unit RPS90/48V HV	Nominal voltage AC	110 - 230 V, 50 - 60 Hz
	Voltage range AC	90 - 265 V, 47 - 63 Hz (incl. max. tolerances)
	Power consumption at 110 V AC	1.00 A
	Power consumption at 230 V AC	0.50 A
	Nominal voltage DC	60 - 250 V
	Voltage range DC	48 - 320 V (incl. max. tolerances)
	Current consumption at 60 V DC	1.70 A
	Current consumption at 250 V DC	0.39 A
	Connection type	3-pin terminal block
	Output voltage	48 - 54 V DC (variable, default value: 48 V DC)
Power output	At up to +60 °C: 90 W At +60 °C to +70 °C: 60 W	
Power failure bypass	> 10 ms	
PoE power unit RPS90/48V LV	Nominal voltage DC	24 - 48 V
	Voltage range DC	18 - 60 V (incl. max. tolerances)
	Current consumption at 24 V DC	4.20 A
	Current consumption at 48 V DC	2.10 A
	Connection type	2-pin terminal block
	Output voltage	48 - 54 V DC (variable, default value: 48 V DC)
	Power output	At up to +60 °C: 90 W At +60 °C to +70 °C: 60 W
Power failure bypass	> 10 ms	
Overload current protection at input	Non-replaceable fuse	
Insulation voltage between operating voltage connections and housing	800 V DC Protective elements limit the insulation voltage to 90 V DC (1mA)	
"FAULT" signal contact	Switching current	max. 1 A, SELV
	Switching voltage	max. 60 V DC or max. 30 V AC, SELV
Environment	Storage temperature (ambient air)	Standard: -40 °C to +70 °C Extended: -40 °C to +85 °C
	Humidity	10% to 95% (non-condensing)
	Air pressure	Up to 2000 m (795 hPa), higher altitudes on request

Operating temperature	RS20/RS30/RS40	Standard: 0 °C to +60 °C Extended: -40 °C to +70 °C
	RS22-..., RS32-...	Extended: -40 °C to +50 °C
	RS40-...B... (ATEX) Standard (S)	Temperature Code T4: 0 °C to +60 °C
	RS40-...B... (ATEX) Extended (E and T)	Temperature Code T3: -40 °C to +70 °C Temperature Code T4: -40 °C to +60 °C
	RPS90/48V HV	-40 °C to +70 °C
	RPS90/48V LV	-40 °C to +70 °C Cold start at temperatures above -30 °C at an input voltage \geq 21.6 V DC
Pollution degree		2
Protection classes	Laser protection	Class 1 according to EN 60825-1 (2001)
	Protection class	IP 20

■ EMC and immunity

EMC interference immunity		A ^{a)}	B ^{a)}	H ^{a)}
IEC/EN 61000-4-2	Electrostatic discharge			
	Contact discharge	4 kV	8 kV	8 kV
	Air discharge	8 kV	15 kV	15 kV
IEC/EN 61000-4-3	Electromagnetic field			
	80 - 3,000 MHz	10 V/m	20 V/m	20 V/m
IEC/EN 61000-4-4	Fast transients (burst)			
	Power line	2 kV	4 kV	4 kV
	Data line	1 kV	4 kV	4 kV
IEC/EN 61000-4-5	Voltage surges			
	Power line, line / line	0.5 kV	1 kV	1 kV
	Power line, line / earth	1 kV	2 kV	2 kV
	Data line	1 kV	4 kV	4 kV
IEC/EN 61000-4-6	Line-conducted interference voltages			
	10 kHz - 150 kHz	3 V	3 V	3 V
	150 kHz - 80 MHz	10 V	10 V	10 V
EN 61000-4-9	Impulse-shaped magnetic fields	—	300 A/m	300 A/m
EMC emitted interference		A ^{a)}	B ^{a)}	H ^{a)}
EN 55022	Class A	Yes	Yes	Yes
FCC 47 CFR Part 15	Class A	Yes	Yes	Yes
German Lloyd	Classification + Construction Guidelines VI-7-3 Part 1 Ed.2001	—	Yes	Yes
Stability		A ^{a)}	B ^{a)}	H ^{a)}
Vibration	IEC 60068-2-6 Test FC test level according to IEC 61131-2	Yes	Yes	Yes
	Germanischer Lloyd Guidelines for the Performance of Type Tests Part 1	—	Yes	Yes

Stability		A ^a	B ^{a)}	H ^{a)}
	IEC 870-2-2 table 3 normal installation according to EN 61850-3	—	Yes	Yes
Shock	IEC 60068-2-27 Test Ea test level according to IEC 61131-2	Yes	Yes	Yes
	IEC 870-2-2 table 3 normal installation according to EN 61850-3	—	Yes	Yes

- a. Product code A: Certification = CE, UL
Product code B: Certification = CE, UL, GL, railway (along track), sub station, ATEX
Product code H: Certification = CE, UL, GL, railway (along track), sub station
(s. [page 16](#) "Combination options for RS20/30" and [page 19](#) "Combination options for RS40")

■ Network range

TP port	
Length of a twisted pair segment	max. 100 m / 328 ft (cat5e cable with 1000BASE-T)

Table 15: TP port 10BASE-T / 100BASE-TX / 1000BASE-T

Product code	Wave length	Fiber	System attenuation	Expansion	Fiber data
-M2, -MM MM	1300 nm	50/125 µm	0-8 dB	0-5 km	1.0 dB/km, 800 MHz*km
-M2, -MM MM	1300 nm	62.5/125 µm	0-11 dB	0-4 km	1.0 dB/km, 500 MHz*km
-S2, -VV SM	1300 nm	9/125 µm	0-16 dB	0-30 km	0.4 dB/km; 3.5 ps/(nm*km)
-E2, EE SM+	1300 nm	9/125 µm	7-29 dB	20-65 km	0.4 dB/km; 3.5 ps/(nm*km)
-L2, -LL LH	1550 nm	9/125 µm	7-29 dB	24-86 km	0.3 dB/km; 19 ps/(nm*km)
-G2, -GG LH+	1550 nm	9/125 µm	14-47 dB	67-176 km	0.25 dB/km; 19 ps/(nm*km)

Table 16: F/O port 100BASE-FX

Product code M-FAST SFP-...	Wave length	Fiber	System attenuation	Expansion	Fiber data
-MM/LC...	MM 1310 nm	50/125 µm	0-8 dB	0-5 km	1.0 dB/km, 800 MHz*km
-MM/LC...	MM 1310 nm	62.5/125 µm	0-11 dB	0-4 km	1.0 dB/km, 500 MHz*km
-SM/LC...	SM 1310 nm	9/125 µm	0-13 dB	0-25 km	0.4 dB/km; 3.5 ps/(nm*km)
-SM+/LC...	SM 1310 nm	9/125 µm	10-29 dB	25-65 km	0.4 dB/km; 3.5 ps/(nm*km)
-LH/LC	SM 1550 nm	9/125 µm	10-29 dB	40-104 km	0.25 dB/km; 19 ps/(nm*km)

Table 17: Fiber port 100BASE-FX (SFP fiber optic Fast ETHERNET Transceiver)

Product code M-SFP-...	Wave length	Fiber	System attenuation	Expansion	Fiber data
-SX/LC...	MM 850 nm	50/125 μ m	0-7.5 dB	0-550 m	3.0 dB/km, 400 MHz*km
-SX/LC...	MM 850 nm	62.5/125 μ m	0-7.5 dB	0-275 m	3.2 dB/km, 200 MHz*km
-MX/LC...	MM 1310 nm	50/125 μ m	0-8 dB	2 km ^a	1.0 dB/km, 500 MHz*km
-MX/LC	MM 1310 nm	62.5/125 μ m	0-8 dB	1 km	1.0 dB/km, 500 MHz*km
-LX/LC...	MM 1310 nm ^b	50/125 μ m	0-11 dB	0-550 m	1.0 dB/km, 800 MHz*km
-LX/LC...	MM 1310 nm ^b	62.5/125 μ m	0-11 dB	0-550 m	1.0 dB/km, 500 MHz*km
-LX/LC...	SM 1310 nm	9/125 μ m	0-11 dB	0-20 km	0.4 dB/km; 3.5 ps/(nm*km)
-LX+/LC	SM 1310 nm	9/125 μ m	5-20 dB	14-42 km	0.4 dB/km; 3.5 ps/(nm*km)
-LH/LC...	LH 1550 nm	9/125 μ m	6-22 dB	24-72 km	0.25 dB/km; 19 ps/(nm*km)
-LH+/LC	LH 1550 nm	9/125 μ m	15-30 dB	71-108 km	0.25 dB/km; 19 ps/(nm*km)
-LH+/LC	LH 1550 nm	9/125 μ m	15-30 dB	71-128 km	0.21 dB/km (typical); 19 ps/(nm*km)

Table 18: Fiber port 1000BASE-FX (SFP fiber optic Gigabit ETHERNET Transceiver)

- a. Distances up to 3 km reachable, 1000 MHz*km (1300 nm)
- b. With F/O adapter compliant with IEEE 802.3-2002 clause 38 (single-mode fiber offset-launch mode conditioning patch cord)

MM = Multimode, SM = Singlemode, LH = Singlemode Longhaul

■ Power consumption/power output

Device name	Device model	Maximum power consumption	Power output
2 uplink ports:			
RS20-0400...	2xTX port	5.3 W	18.1 Btu (IT)/h
RS20-0400...	1xFX port, 1xTX port	6.5 W	22.2 Btu (IT)/h
RS20-0400...	2xFX port	7.7 W	26.3 Btu (IT)/h
RS20-0800...	RS22-0800... 2xTX port	5.3 W	18.1 Btu (IT)/h
RS20-0800...	RS22-0800... 1xFX port, 1xTX port	6.5 W	22.2 Btu (IT)/h
RS20-0800...	RS22-0800... 2xFX port	7.7 W	26.3 Btu (IT)/h
RS20-1600...	RS22-1600... 2xTX port	9.4 W	32.1 Btu (IT)/h
RS20-1600...	RS22-1600... 1xFX port, 1xTX port	10.6 W	36.2 Btu (IT)/h
RS20-1600...	RS22-1600... 2xFX port	11.8 W	40.3 Btu (IT)/h
RS20-2400-...	RS22-2400-... 2xTX port	12.1 W	41.3 Btu (IT)/h
RS20-2400-...	RS22-2400-... 1xFX port, 1xTX port	13.3 W	45.4 Btu (IT)/h
RS20-2400-...	RS22-2400-... 2xFX port	14.5 W	52.9 Btu (IT)/h
RS30-0802-...	RS32-0802-... 2xTX port	8.9 W	30.4 Btu (IT)/h
RS30-0802-...	RS32-0802-... 1xFX port, 1xTX port	8.6 W	29.4 Btu (IT)/h
RS30-0802-...	RS32-0802-... 2xFX port	8.3 W	28.4 Btu (IT)/h
RS30-1602-...	RS32-1602-... 2xTX port	13.0 W	44.4 Btu (IT)/h
RS30-1602-...	RS32-1602-... 1xFX port, 1xTX port	12.7 W	43.4 Btu (IT)/h
RS30-1602-...	RS32-1602-... 2xFX port	12.4 W	42.4 Btu (IT)/h
RS30-2402-...	RS32-2402-... 2xTX port	15.7 W	53.6 Btu (IT)/h
RS30-2402-...	RS32-2402-... 1xFX port, 1xTX port	15.4 W	52.6 Btu (IT)/h
RS30-2402-...	RS32-2402-... 2xFX port	15.1 W	51.6 Btu (IT)/h
3 uplink ports:			
RS20-0900-...	RS22-0900-... 3xFX port	9.6 W	32.8 Btu (IT)/h
RS20-1700-...	RS22-1700-... 3xFX port	13.7 W	46.7 Btu (IT)/h
RS20-2500-...	RS22-2500-... 3xFX port	16.4 W	56.0 Btu (IT)/h
4 uplink ports:			
RS30-0802-...	RS32-0802-... 4xFX port	12.7 W	43.3 Btu (IT)/h
RS30-1602-...	RS32-1602-... 4xFX port	16.8 W	57.3 Btu (IT)/h
RS30-2402-...	RS32-2402-... 4xFX port	19.5 W	66.5 Btu (IT)/h
RS40-...	4xFX port	20.0 W	68.2 Btu (IT)/h

Table 19: Power consumption/power output RS20/RS30/RS40 and RS22/RS32 without PDs (powered devices)

Device name	Device model	Maximum power consumption	Power output
2 uplink ports:			
RS22-0800...	2xTX port	70.9 W	31.8 Btu (IT)/h
RS22-0800...	1xFX port, 1xTX port	72.1 W	35.9 Btu (IT)/h
RS22-0800...	2xFX port	73.3 W	40.0 Btu (IT)/h
RS22-1600...	2xTX port	75.0 W	45.8 Btu (IT)/h
RS22-1600...	1xFX port, 1xTX port	76.2 W	49.9 Btu (IT)/h
RS22-1600...	2xFX port	77.4 W	54.0 Btu (IT)/h
RS22-2400-...	2xTX port	77.7 W	55.0 Btu (IT)/h
RS22-2400-...	1xFX port, 1xTX port	78.9 W	59.1 Btu (IT)/h
RS22-2400-...	2xFX port	80.1 W	66.6 Btu (IT)/h
RS32-0802-...	2xTX port	74.5 W	44.1 Btu (IT)/h
RS32-0802-...	1xFX port, 1xTX port	74.2 W	43.1 Btu (IT)/h
RS32-0802-...	2xFX port	73.9 W	42.1 Btu (IT)/h
RS32-1602-...	2xTX port	78.6 W	58.1 Btu (IT)/h
RS32-1602-...	1xFX port, 1xTX port	78.3 W	57.1 Btu (IT)/h
RS32-1602-...	2xFX port	78.0 W	56.1 Btu (IT)/h
RS32-2402-...	2xTX port	81.3 W	67.3 Btu (IT)/h
RS32-2402-...	1xFX port, 1xTX port	81.0 W	66.3 Btu (IT)/h
RS32-2402-...	2xFX port	80.7 W	65.3 Btu (IT)/h
3 uplink ports:			
RS22-0900-...	3xFX port	75.2 W	46.5 Btu (IT)/h
RS22-1700-...	3xFX port	79.3 W	60.4 Btu (IT)/h
RS22-2500-...	3xFX port	82.0 W	69.7 Btu (IT)/h
4 uplink ports:			
RS32-0802-...	4xFX port	78.3 W	57.0 Btu (IT)/h
RS32-1602-...	4xFX port	82.4 W	71.0 Btu (IT)/h
RS32-2402-...	4xFX port	85.1 W	80.2 Btu (IT)/h

Table 20: Power consumption/power output RS22/RS32 with 4 x Class0 PD (powered device)

■ Scope of delivery

Device	Scope of delivery
RS20-..., RS30-..., RS40-..., RS22-... or RS32-...	Device Terminal block for supply voltage and signal contact Installation user manual and CD-ROM
RS22-16..., RS22-17..., RS22-24..., RS22-25...	Additionally: ferrite with key

■ Order numbers/product description

See table on [page 16 "Combination options for RS20/30"](#) and table on [page 19 "Combination options for RS40"](#).

■ Accessories

Name	Operating temperature (chassis)	Order number
6-pin terminal block (50 pcs.)		943 845-006
AutoConfiguration Adapter ACA 11		943 751-001
AutoConfiguration Adapter ACA 21-USB		943 271-001
HiVision Network Management software		943 471-100
OPC Server software HiOPC		943 055-001
RPS 90/48V HV (high-voltage) PoE power unit		943 979-001
RPS 90/48V HV (high-voltage) PoE power unit with conformal coating		943 979-101
RPS 90/48V LV (low-voltage) PoE power unit		943 980-001
RPS 90/48V LV (low-voltage) PoE power unit with conformal coating		943 980-101
Pocket Guide		280 710-851
Rail Power Supply RPS 30		943 662-003
Rail Power Supply RPS 80 EEC		943 662-080
Rail Power Supply RPS 120 EEC		943 662-120
Terminal cable		943 301-001
Wall mounting plate for mounting the RS22/RS32 on the wall		
Wall mounting plate, width 120 mm		943 971-001
Wall mounting plate, width 90 mm		943 971-002
Wall mounting plate, width 60 mm		943 971-003
Gigabit ETHERNET SFP Transceiver		
M-SFP-SX/LC	0 °C to +60 °C	943 014-001
M - SFP - SX / LC EEC	-40 °C to +70 °C	943 896-001
M - SFP - MX / LC	0 °C to +60 °C	942 035-001
M-SFP-LX/LC	0 °C to +60 °C	943 015-001
M - SFP - LX / LC EEC	-40 °C to +70 °C	943 897-001
M - SFP - LX+ / LC	0 °C to +60 °C	942 023-001
M - SFP - LX+ / LC EEC	-40 °C to +70 °C	942 024-001
M-SFP-LH/LC	0 °C to +60 °C	943 042-001
M - SFP - LH / LC EEC	-40 °C to +70 °C	943 898-001
M-SFP-LH+/LC	0 °C to +60 °C	943 049-001
Fast ETHERNET SFP Transceiver		
M-FAST SFP-MM/LC	0 °C to +60 °C	943 865-001
M-FAST SFP-MM/LC EEC	-40 °C to +70 °C	943 945-001
M-FAST SFP-SM/LC	0 °C to +60 °C	943 866-001
M-FAST SFP-SM/LC EEC	-40 °C to +70 °C	943 946-001
M-FAST SFP-SM+/LC	0 °C to +60 °C	943 867-001
M-FAST SFP-SM+/LC EEC	-40 °C to +70 °C	943 947-001
M-FAST SFP-LH/LC	0 °C to +60 °C	943 868-001
M-FAST SFP-LH/LC EEC	-40 °C to +70 °C	943 948-001
Bidirectional Gigabit ETHERNET SFP Transceiver		
M-SFP-BIDI Type A LX/LC EEC	-40 °C to +85 °C	943 974-001

Name	Operating temperature (chassis)	Order number
M-SFP-BIDI Type B LX/LC EEC	-40 °C to +70 °C	943 974-002
M-SFP-BIDI Type A LH/LC EEC	-40 °C to +70 °C	943 975-001
M-SFP-BIDI Type B LH/LC EEC	-40 °C to +70 °C	943 975-002
M-SFP-BIDI Bundle LX/LC EEC (Type A + B)	-40 °C to +70 °C	943 974-101
M-SFP-BIDI Bundle LH/LC EEC (Type A + B)	-40 °C to +70 °C	943 975-101

■ Underlying norms and standards

Name	
cUL 508:1998	Safety for Industrial Control Equipment
EN 50121-4:2006	Railway applications - EMC - emitted interference and interference immunity for signal and telecommunication systems
EN 55022:2006 + A1:2007	IT equipment – radio interference characteristics
EN 60079-15	Electrical equipment for explosive gas atmospheres – part 15: Construction, testing and marking of protection type "n" electrical apparatus.
EN 61000-6-2:2005	Generic norm – immunity in industrial environments
EN 61131-2:2007	Programmable logic controllers
FCC 47 CFR Part 15:2009	Code of Federal Regulations
Germanischer Lloyd	Ship Applications - Classification and Construction Guidelines VI-7-3 Part 1 Ed.2003
IEC/EN 60950-1:2006	Safety for the installation of IT equipment
IEC/EN 61850-3	Communications networks and systems in stations
IEEE 802.1 D	Switching, GARP, GMRP, Spanning Tree
IEEE 802.1 D-1998	Media access control (MAC) bridges (includes IEEE 802.1p Priority and Dynamic Multicast Filtering, GARP, GMRP)
IEEE 802.1 Q	Tagging
IEEE 802.1 Q-1998	Virtual Bridged Local Area Networks (VLAN Tagging, GVRP)
IEEE 802.1 w.2001	Rapid Reconfiguration
IEEE 802.3-2002	Ethernet
IEEE 1613	Standard Environment and Testing Requirements for Communication Networking Devices in Electric Power Substations
ISA 12.12.01 (cUL 1604), CSA C22.2 No. 213	Electrical Equipment for Use in Class I and Class II, Div.2 and Class III Hazardous (Classified) Locations
KR	Korean Register of Shipping

Table 21: List of norms and standards

The device has a certification based on a specific standard only if the certification indicator appears on the housing. However, with the exception of Germanischer Lloyd, ship certifications as well as RINA certifications are only included in the product information under www.beldensolutions.com. Use shielded twisted pair cables to fulfill the more stringent EMC requirements for the particular certifications.

A Further Support

■ Technical Questions and Training Courses

In the event of technical queries, please contact your local Hirschmann distributor or Hirschmann office.

You can find the addresses of our distributors on the Internet:

www.beldensolutions.com.

Our support line is also at your disposal:

▶ Tel. +49 1805 14-1538

▶ Fax +49 7127 14-1551

Answers to Frequently Asked Questions can be found on the Hirschmann internet site (www.beldensolutions.com) at the end of the product sites in the FAQ category.

The current training courses to technology and products can be found under <http://www.hicomcenter.com>.

■ Hirschmann Competence Center

In the long term, excellent products alone do not guarantee a successful customer relationship. Only comprehensive service makes a difference worldwide. In the current global competition scenario, the Hirschmann Competence Center is ahead of its competitors on three counts with its complete range of innovative services:

- ▶ Consulting incorporates comprehensive technical advice, from system evaluation through network planning to project planing.
- ▶ Training offers you an introduction to the basics, product briefing and user training with certification.
- ▶ Support ranges from the first installation through the standby service to maintenance concepts.

With the Hirschmann Competence Center, you have decided against making any compromises. Our client-customized package leaves you free to choose the service components you want to use.

Internet:

<http://www.hicomcenter.com>.



HIRSCHMANN

A **BELDEN** BRAND