

34HY SERIES 1.8°

Key Features

- Low Noise
- Low Inertia
- High Acceleration

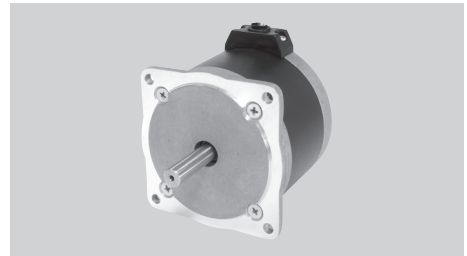

General Specifications

- 8-Leadwire Motors

Series & Length	Model Number	Holding Torque		Rated Current	Resistance per Phase	Inductance per Phase	Detent Torque		Rotor Inertia	
		mN.m	oz-in	A	ohm	mH	mN.m	oz-in	g.cm ²	oz-in ²
34HY0 63 mm (2.48 in.)	34HY0809 Bi-polar Parallel	2300	326.0	1.8	2.3	18	120	17.00	560	3.08
	34HY0809 Bi-polar Series	2300	326.0	0.9	9.2	72				
	34HY0809 Unipolar	1800	255.1	1.3	4.6	18				
	34HY0810 Bi-polar Parallel	2300	326.0	4.2	0.6	3.6				
	34HY0810 Bi-polar Series	2300	326.0	2.1	2.4	14.4				
	34HY0810 Unipolar	1800	255.1	3	1.2	3.6				
34HY1 91 mm (3.58 in.)	34HY1801-10 Bi-polar Parallel	4000	566.9	5.6	0.3	2.4	210	29.75	1200	6.60
	34HY1801-10 Bi-polar Series	4000	566.9	2.8	1.2	9.6				
	34HY1801-10 Unipolar	3100	439.3	4	0.6	2.4				
	34HY1803 Bi-polar Parallel	4600	651.9	3.9	0.8	6.7				
	34HY1803 Bi-polar Series	4600	651.9	1.9	3.2	26.8				
	34HY1803 Unipolar	3500	496.0	2.8	1.6	6.7				
34HY2 130 mm (5.12 in.)	34HY2801 Bi-polar Parallel	7800	1105.4	8.4	0.47	4	180	25.50	2100	11.55
	34HY2801 Bi-polar Series	7800	1105.4	4.2	1.88	16				
	34HY2801 Unipolar	6000	850.3	6	0.94	4				
	34HY2802 Bi-polar Parallel	5600	793.7	9.4	0.19	1.6				
	34HY2802 Bi-polar Series	5600	793.7	4.7	0.76	6				
	34HY2802 Unipolar	4300	609.4	6.7	0.38	1.5				

- Wiring Connection, Lead Wires, Schematic Diagrams & Stepping Sequence.....Page 62 - 64

Mechanical Dimension

Series	L	Mass
	mm (in.)	kg (lb.)
34HY0	63 (2.48)	1.5 (3.31)
34HY1	91 (3.58)	2.6 (5.73)
34HY2	130 (5.12)	3.6 (7.94)

Unit: mm(inch)

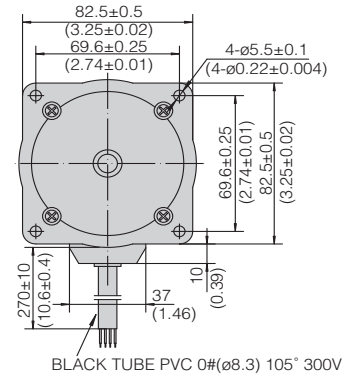
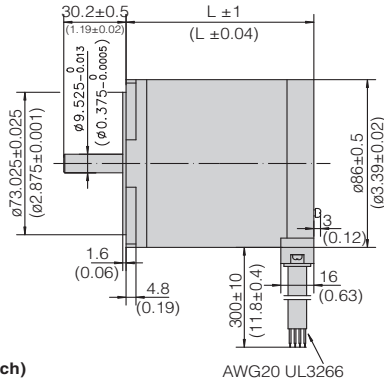

Dynamic Torque Curves

8-Leadwire Motors

34HY0809 Bi-polar Parallel

Conditions: Bi-polar Constant Current Driver
Driver: AMA MS7080M
Mode: Full Step

1.8A(Peak) 48V 1.8A(Peak) 60V

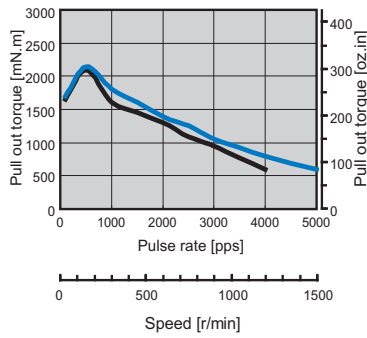

34HY0809 Bi-polar series

Conditions: Bi-polar Constant Current Driver
Driver: AMA MS7080M
Mode: Full Step

0.9A(Peak) 48V 0.9A(Peak) 60V

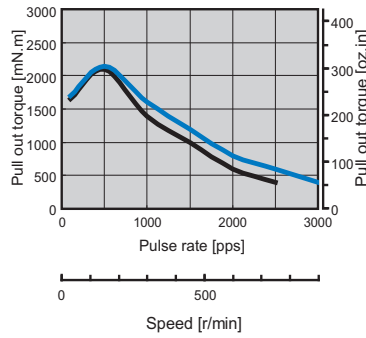

34HY0809 Uni-polar

Conditions: Uni-polar Constant Current Driver
Driver: AMA MSU8080M
Mode: Full Step

1.3A(Peak) 48V 1.3A(Peak) 60V

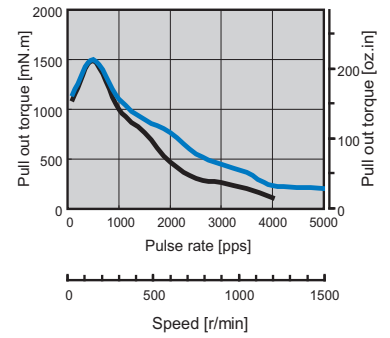

34HY0810 Bi-polar Parallel

Conditions: Bi-polar Constant Current Driver
Driver: AMA MS7080M
Mode: Full Step

4.2A(Peak) 48V 4.2A(Peak) 60V

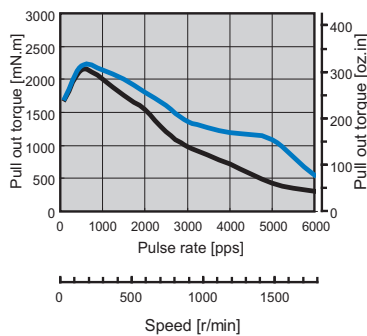

34HY0810 Bi-polar series

Conditions: Bi-polar Constant Current Driver
Driver: AMA MS7080M
Mode: Full Step

2.1A(Peak) 48V 2.1A(Peak) 60V

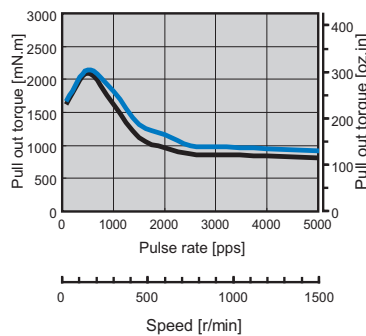

34HY0810 Uni-polar

Conditions: Uni-polar Constant Current Driver
Driver: AMA MSU8080M
Mode: Full Step

3.0A(Peak) 48V 3.0A(Peak) 60V

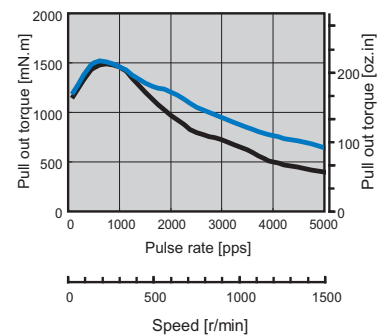

Dynamic Torque Curves

- 8-Leadwire Motors

34HY1801-10 Bi-polar Parallel

Conditions:Bi-polar Constant Current Driver
Driver: AMA MSU8080M
Mode:Full Step

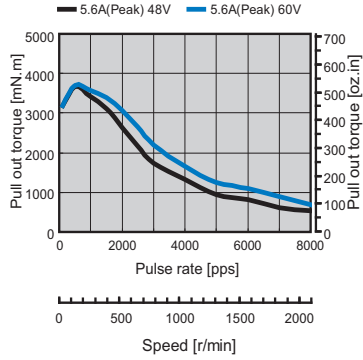

34HY1801-10 Bi-polar Series

Conditions:Bi-polar Constant Current Driver
Driver: AMA MSU8080M
Mode:Full Step

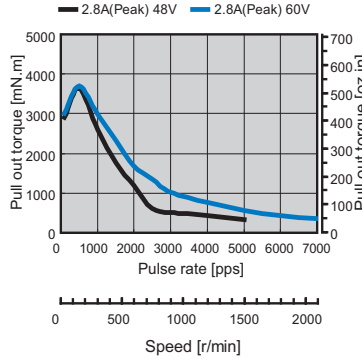

34HY1801-10 Uni-polar

Conditions:Uni-polar Constant Current Driver
Driver: AMA MSU8080M
Mode:Full Step

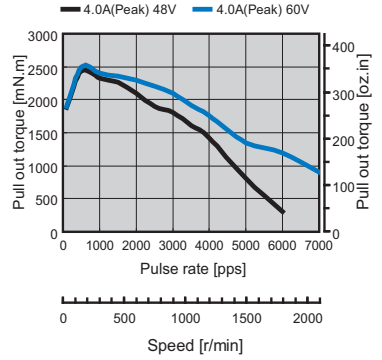

34HY1803 Bi-polar Parallel

Conditions:Bi-polar Constant Current Driver
Driver: AMA MS7080M
Mode:Full Step

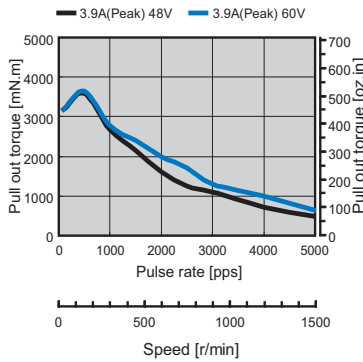

34HY1803 Bi-polar Series

Conditions:Bi-polar Constant Current Driver
Driver: AMA MS7080M
Mode:Full Step

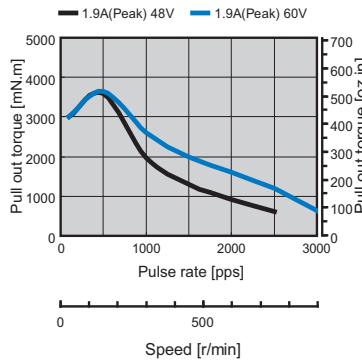

34HY1803 Uni-polar

Conditions:Uni-polar Constant Current Driver
Driver: AMA MSU8080M
Mode:Full Step

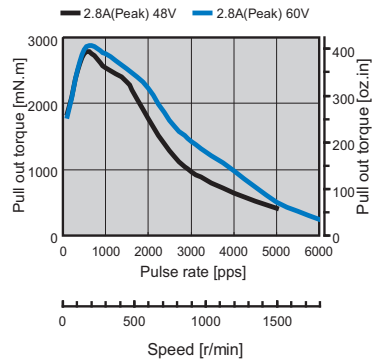

34HY2801 Bi-polar Parallel

Conditions:Bi-polar Constant Current Driver
Driver: AMA MS7080M
Mode:Full Step

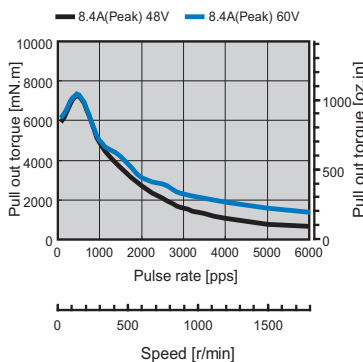

34HY2801 Bi-polar Series

Conditions:Bi-polar Constant Current Driver
Driver: AMA MS7080M
Mode:Full Step

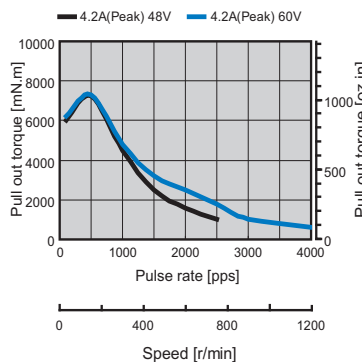

34HY2801 Uni-polar

Conditions:Uni-polar Constant Current Driver
Driver: AMA MSU8080M
Mode:Full Step

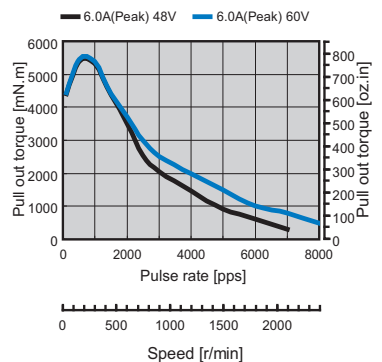

Dynamic Torque Curves

- 8-Leadwire Motors

34HY2802 Bi-polar Parallel

Conditions: Bi-polar Constant Current Driver
 Driver: AMA MS7080M
 Mode: Full Step

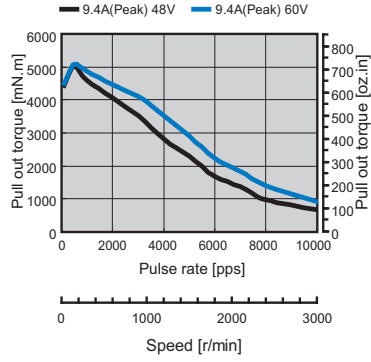

34HY2802 Bi-polar Series

Conditions: Bi-polar Constant Current Driver
 Driver: AMA MS7080M
 Mode: Full Step

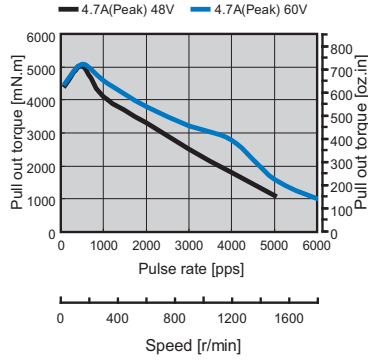

34HY2802 Uni-polar

Conditions: Uni-polar Constant Current Driver
 Driver: AMA MSU8080M
 Mode: Full Step

