

EC-i 30 Ø30 mm, brushless, 45 Watt

High Torque

NEW

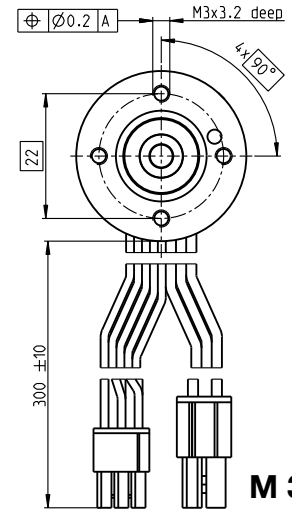
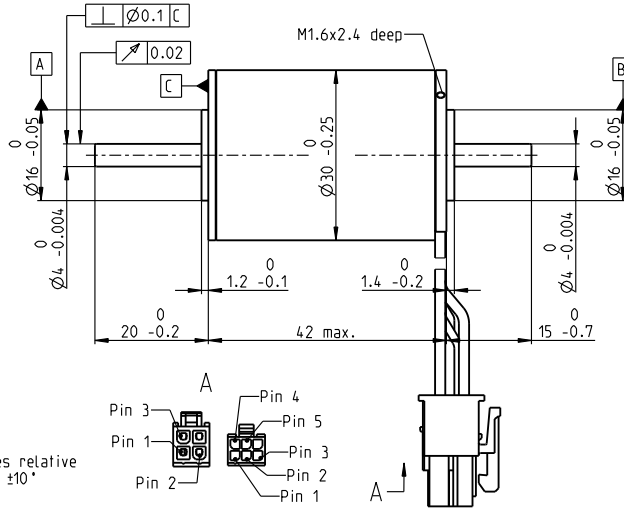
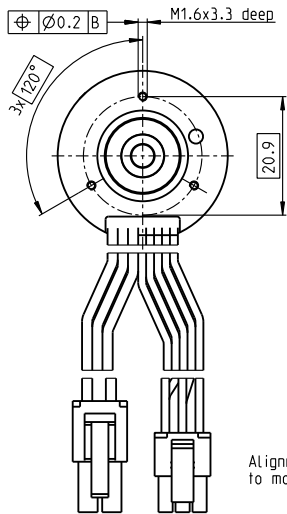

Alignment of cables relative to mounting holes ±10°

M 3:4

- Stock program
- Standard program
- Special program (on request)

Part Numbers

with Hall sensors

539480 539481 **539482** 539483 539484

Motor Data (provisional)

Values at nominal voltage		12	18	24	36	48
1 Nominal voltage	V	12	18	24	36	48
2 No load speed	rpm	8250	8250	8520	8250	8520
3 No load current	mA	273	182	143	91.1	71.5
4 Nominal speed	rpm	6710	6760	7030	6790	7050
5 Nominal torque (max. continuous torque)	mNm	65.4	67.7	63.8	67.6	63.8
6 Nominal current (max. continuous current)	A	4.51	3.09	2.28	1.54	1.14
7 Stall torque ¹	mNm	731	840	811	885	835
8 Stall current	A	53.2	40.8	30.5	21.5	15.7
9 Max. efficiency	%	86.3	87.2	86.9	87.5	87.1
Characteristics						
10 Terminal resistance phase to phase	Ω	0.225	0.441	0.787	1.68	3.06
11 Terminal inductance phase to phase	mH	0.199	0.449	0.749	1.8	3
12 Torque constant	mNm/A	13.7	20.6	26.6	41.2	53.2
13 Speed constant	rpm/V	696	464	359	232	180
14 Speed/torque gradient	rpm/mNm	11.4	9.94	10.6	9.43	10.3
15 Mechanical time constant	ms	0.969	0.843	0.902	0.8	0.876
16 Rotor inertia	gcm ²	8.1	8.1	8.1	8.1	8.1

Specifications

Thermal data	
17 Thermal resistance housing-ambient	11.1 K/W
18 Thermal resistance winding-housing	3.75 K/W
19 Thermal time constant winding	27.8 s
20 Thermal time constant motor	866 s
21 Ambient temperature	-40...+100°C
22 Max. winding temperature	+155°C
Mechanical data (preloaded ball bearings)	
23 Max. speed	10000 rpm
24 Axial play at axial load < 9.0 N	0 mm
> 9.0 N	0.14 mm preloaded
25 Radial play	5 N
26 Max. axial load (dynamic)	98 N
27 Max. force for press fits (static) (static, shaft supported)	2000 N
28 Max. radial load, 5 mm from flange	25 N

Other specifications

29 Number of pole pairs	4
30 Number of phases	3
31 Weight of motor	156 g

Values listed in the table are nominal.

Connection motor (Cable AWG 20)		
red	Motor winding 1	Pin 1
black	Motor winding 2	Pin 2
white	Motor winding 3	Pin 3
	N.C.	Pin 4

Connector Article number		
Molex	39-01-2040	
Connection sensors (Cable AWG 26)		
yellow	Hall sensor 1	Pin 1
brown	Hall sensor 2	Pin 2
grey	Hall sensor 3	Pin 3
blue	GND	Pin 4
green	V _{Hall} 4.5...24 VDC	Pin 5
	N.C.	Pin 6

Connector Article number
Molex 430-25-0600
Wiring diagram for Hall sensors see p. 43
¹Calculation does not include saturation effect (p. 53/164)

Operating Range

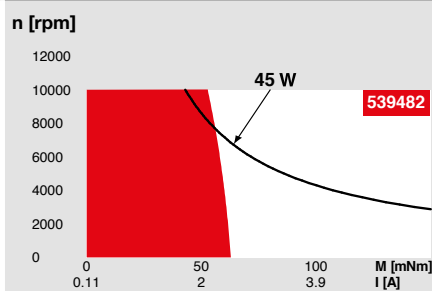

Comments

- Continuous operation**
In observation of above listed thermal resistance (lines 17 and 18) the maximum permissible winding temperature will be reached during continuous operation at 25°C ambient.
= Thermal limit.
- Short term operation**
The motor may be briefly overloaded (recurring).
- Assigned power rating**

maxon Modular System

Overview on page 28–36

Planetary Gearhead

Ø32 mm
1.0 - 6.0 Nm
Page 347

Screw Drive
Ø32 mm
Page 374–378

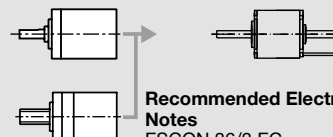

Recommended Electronics:

Notes	Page 32
ESCON 36/3 EC	445
ESCON Mod. 50/4 EC-S	445
ESCON Mod. 50/5	445
ESCON 50/5	447
DEC Module 50/5	449
EPOS2 P 24/5	464
EPOS4 50/5	453
EPOS4 Mod./Comp. 50/5	453
MAXPOS 50/5	468

Encoder 16 EASY

128 - 1024 CPT, 3 channels
Page 409

Encoder 16 EASY Absolute

4096 steps
Page 411

Encoder 16 RIO

1024 - 32768 CPT, 3 channels
Page 423

Encoder HEDL 5540

500 CPT, 3 channels
Page 427

Encoder AEDL 5810

1024 - 5000 CPT, 3 channels
Page 434