

OEM pressure transmitter for general industrial applications Model OT-1

WIKA data sheet PE 81.42

Applications

General industrial applications

- Machine building
- Hydraulics
- Pneumatics

Special features

- Fully automated production for OEM volumes
- Compact design
- MTTFd values > 100 years



Pressure transmitter model OT-1

Description

For universal application

The OT-1 is the ideal product for customers who want to use a cost optimised pressure transmitter.

As many electrical output signals and pressure connections are available, the pressure transmitter can be easily integrated into a wide variety of applications.

The case consists of a highly resistive, fiberglass-enforced plastic material (PBT). This material has been successfully used in the automotive industry for many years. Inside the case a metal pod is responsible for a good EMI-protection.

Excellent performance

The hermetically welded thin film measuring cell guarantees long-term leak tightness. There are no additional sealing materials required.

The thin film measuring cell is made of high quality stainless steel using sputtering technology to offer high long-term stability and excellent burst pressure values.

Interesting price/performance ratio

The pressure transmitter OT-1 has been specially developed for OEM applications in the machine building industry, particularly hydraulics and pneumatics. The transmitter is manufactured on a fully automated production line.

Especially for high-volume OEM requirements this product concept is particularly interesting due to its excellent price/performance ratio.

Individual versions to customer specifications

Due to its manufacturing know-how gained in many years of experience WIKA can offer customised solutions.

Specifications

Model OT-1

Pressure ranges	bar	6	10	16	25	40	60	100	160	250	400	600	
Over pressure safety	bar	20	20	32	50	80	120	200	320	500	800	1200	
Burst pressure	bar	100	100	160	250	400	550	800	1000	1200	1700	2400	
Materials													
■ Wetted parts		Stainless steel											
■ Case		Highly resistive, fiberglass-enforced plastic (PBT)											
		Signal output					Power supply U _B			Maximum load R _A			
		4 ... 20 mA, 2-wire					DC 8 ... 36 V			R _A ≤ (U _B - 8 V) / 0.02 A			
		1 ... 6 V, 3-wire					DC 9 ... 36 V			R _A > 2.5 kOhm			
		1 ... 5 V, 3-wire					DC 8 ... 36 V			R _A > 2.5 kOhm			
		0 ... 10 V, 3-wire					DC 14 ... 36 V			R _A > 5 kOhm			
		0.5 ... 4.5 V, ratiometric					DC 5 ± 0.5 V			R _A > 4.5 kOhm			
		Others on request											
Response time (10 ... 90 %)	ms	≤ 2											
Insulation voltage		DC 500 V											
Accuracy *)	% of span	≤ 1.0											
	% of span	≤ 2.0 for pressure ranges ≤ 16 bar											
		*) Including non-linearity, hysteresis, non-repeatability, zero point and full scale error (corresponds to error of measurement per IEC 61298-2).											
Non-linearity	% of span	≤ 0.4 typ. (BFSL) according to IEC 61298-2											
1-year stability	% of span	≤ 0.3 (at reference conditions)											
Permissible temperature of													
■ Medium		-40 ... +125 °C					-40 ... +257 °F						
■ Ambience		-40 ... +100 °C					-40 ... +212 °F						
		With cable version limited temperature range from -40 ... +90 °C / -40 ... +194 °F											
■ Storage		-40 ... +120 °C					-40 ... +248 °F						
		With cable version limited temperature range from -40 ... +90 °C / -40 ... +194 °F											
Rated temperature range		0 ... +80 °C					+32 ... 176 °F						
Temperature error within rated temperature range	% of span	≤ 1 typ. ≤ 1.5 max.											
CE-conformity													
■ Pressure equipment directive		97/23/EC											
■ EMC directive		2004/108/EC, EN 61 326 Emission (Group 1, Class B) and Immunity (industrial locations)											
Wiring protection													
■ Short-circuit proofness		Sig+ towards UB-											
■ Reverse polarity protection		UB+ towards UB-											
Mass	g	Ca. 70											

Dimensions in mm

Electrical connections

Circular connector
M 12x1

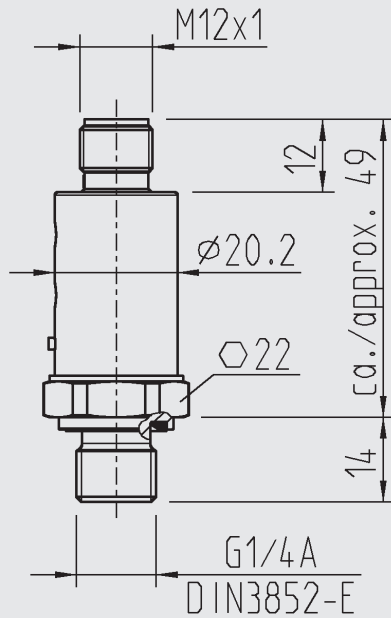

Connector
Metri Pack Serie 150

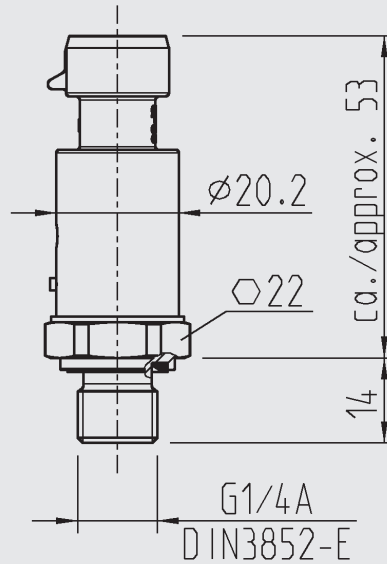

Flying leads

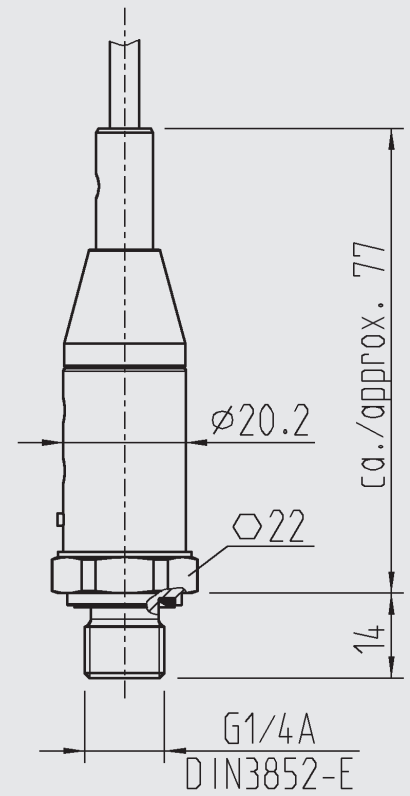

Others on request.

Pressure connections

G 1/4
DIN 3852-E
with sealing NBR {FKM}

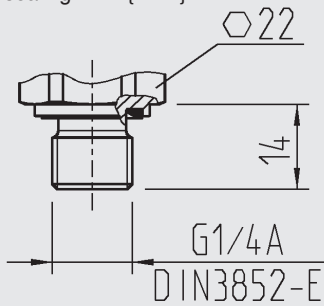

G 1/4
EN 837

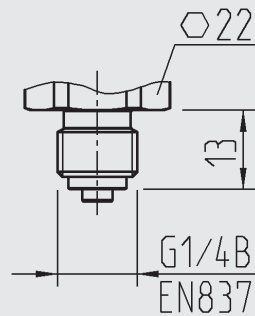

M 14x1,5
DIN 3852-E

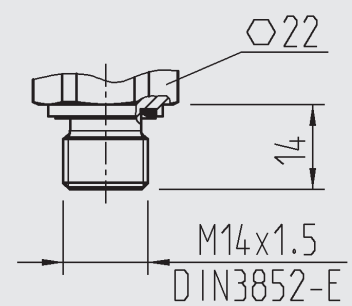

1/4 NPT
ANSI/ASME B1.20.1

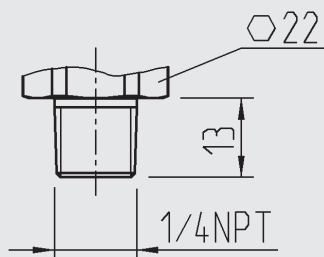

Others on request.

For installation and safety instructions see the operating instructions for this product.

For tapped holes and welding sockets please see Technical Information IN 00.14 for download at www.wika.de

Electrical connections

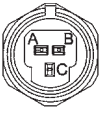
Electrical connections							
	M 12x1 circular connector, 4-pin			Connector Metri Pack Series 150 3-pin			Flying leads (PVC with 0.5 m or 2 m length)
							
2-wire	U+ = 1	U- = 3		U+ = B	U- = A		U+ = brown U- = green
3-wire	U+ = 1	U- = 3	S+ = 4	U+ = B	U- = A	S+ = C	U+ = brown U- = green S+ = white
Wire gauge	-			-			0.34 mm ² (with end splices)
Diameter of cable	-			-			5.2 mm
Ingress protection per IEC 60 529	IP 67			IP 67			IP 67
The ingress protection classes specified only apply while the pressure transmitter is connected with female connectors that provide the corresponding ingress protection.							

Legend:

- 2-wire The two connection lines are used for the power supply.
The measurement signal also provides the supply current.
- 3-wire Two of the connection lines are used for the power supply.
One connection line is used for the measurement signal.
- U+ Positive power terminal
- U- Negative power terminal
- S+ Positive measurement terminal

The specifications given in this document represent the state of engineering at the time of publishing.
We reserve the right to make modifications to the specifications and materials.

