

»» Features

- 10.5mm slim type miniature PCB Relay.
- UL/CUL, TUV approved.
- High ratings 7A 250VAC and high insulation 2500V between coils to contacts.
- Special design for household appliances applications.
- Flux free and sealed types are both available.
- Comply with RoHS-Directive 2002/95/EC, and ELV-Directive 2000/53/EC.
- Relay with AgCdO contact material do not comply with the Directives.

»» Type List

◆ Standard Type

Terminal style	Contact form	High insulation type	Designation		
			Flux tight	Sealed type	Sealed type washable
PCB terminal	1A (SPNO)	-----	851-1A-C	851-1A-V	851-1A-S
		B	851B-1A-C	851B-1A-V	851B-1A-S
	1C (SPDT)	-----	851-1C-C	851-1C-V	851-1C-S
		B	851B-1C-C	851B-1C-V	851B-1C-S

◆ High Power Type

PCB terminal	1A (SPNO)	-----	851H-1A-C	851H-1A-V	851H-1A-S
		B	851HB-1A-C	851HB-1A-V	851HB-1A-S
	1C (SPDT)	-----	851H-1C-C	851H-1C-V	851H-1C-S
		B	851HB-1C-C	851HB-1C-V	851HB-1C-S

◆ High Sensitivity Type

PCB terminal	1A (SPNO)	-----	851N-1A-C	851N-1A-V	851N-1A-S
		B	851NB-1A-C	851NB-1A-V	851NB-1A-S
	1C (SPDT)	-----	851N-1C-C	851N-1C-V	851N-1C-S
		B	851NB-1C-C	851NB-1C-V	851NB-1C-S

»» Ordering Information

851 H N B - 1A - F - C
1 2 3 4 5 6 7

1. 851 -- Basic series designation

2. Blank -- Standard type
H -- High power type

3. Blank -- Standard type
N -- High sensitivity type

4. Blank -- Standard type
B -- High insulation type

5. 1A -- Single pole normally open
1B -- Single pole normally closed
1C -- Single pole double throw

6. Blank -- Standard type
F -- Class F

7. C -- Flux tight
V -- Sealed type
S -- Sealed type washable

»» Contact Rating

Load type	851	851H
Resistive load	5A 250VAC	7A 250VAC

»» Coil Rating (DC)

◆ Standard Type

Rated voltage (V)	Rated current ±10% at 23 °C (mA)	Coil resistance ±10% at 23 °C (Ω)	Max. continuous voltage at 85 °C	Pick up voltage(Max) at 23 °C	Drop out voltage(Min) at 23 °C	Power consumption at rated voltage
3	120	25	160% of rated voltage	75% of rated voltage	5% of rated voltage	approx. 0.36W
5	72.5	69				
6	60	100				
9	40	225				
12	30	400				
18	20	900				
24	15	1600				
36	10	3600				
48	7.5	6400				

◆ High Sensitivity Type

Rated voltage (V)	Rated current ±10% at 23 °C (mA)	Coil resistance ±10% at 23 °C (Ω)	Max. continuous voltage at 85 °C	Pick up voltage(Max) at 23 °C	Drop out voltage(Min) at 23 °C	Power consumption at rated voltage
3	83.3	36	170% of rated voltage	75% of rated voltage	5% of rated voltage	approx. 0.25W
5	50	100				
6	41.3	145				
9	27.7	325				
12	20.9	575				
18	13.8	1300				
24	10.4	2310				
36	6.9	5180				

»» Specification

Contact material	AgCdO / AgSnO alloy	
Contact resistance ⁽¹⁾	100mΩ Max.	
Operate time ⁽¹⁾	10ms Max.	
Release time ⁽¹⁾	5ms Max.	
Insulation resistance ⁽¹⁾	1000 MΩ Min. (DC 500V)	
Dielectric strength ⁽¹⁾	Between open contact : AC750V,50/60Hz 1 min.	
	Between contact and coil : AC2000V,50/60Hz 1 min.	
	: AC2500V,50/60Hz 1 min. (for High insulation type)	
Vibration resistance	Operating extremes	10~55Hz, amplitude 1.5 mm
	Damage limits	10~55Hz, amplitude 1.5 mm
Shock resistance	Operating extremes	10G
	Damage limits	50G
Life expectancy	Mechanical	10,000,000 operations (frequency 18,000 operations/hr)
	Electrical	100,000 operations (frequency 1,200 operations/hr)
Operating ambient temperature	-40~+85 °C (no freezing)	
Weight	Approx. 8g	

Note : (1) initial value

»» Safety Approval

Certified	UL / CUL	TUV
File No.	E88991	R 09854137

»» Safety Approval Rating

◆ UL / CUL

851		851H	
NO	NC	NO	NC
7A 277VAC	5A 277VAC	10A 277VAC	7A 277VAC
7A 30VDC	5A 30VDC	7A 30VDC	7A 30VDC
1/10HP 125/250VAC	1/10HP 125/250VAC	1/4HP 125/250VAC	1/4HP 125/250VAC

◆ TUV

851		851H	
NO	NC	NO	NC
7A 250VAC	5A 250VAC	10A 250VAC	7A 250VAC
5A 250VAC cosφ0.4	3A 250VAC cosφ0.4	7A 250VAC cosφ0.4	5A 250VAC cosφ0.4
7A 30VDC	5A 30VDC	7A 30VDC	7A 30VDC

»» Outline Dimensions

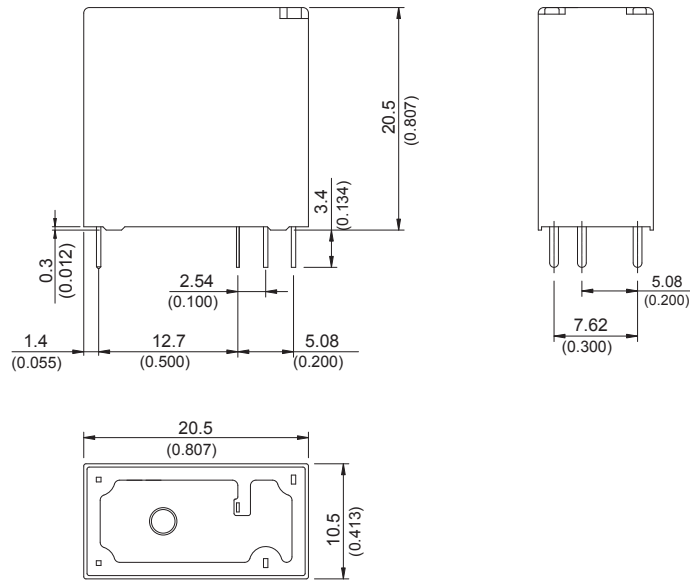

»» Wiring Diagram BOTTOM VIEW

1C



1A



1B



»» PC Board Layout BOTTOM VIEW

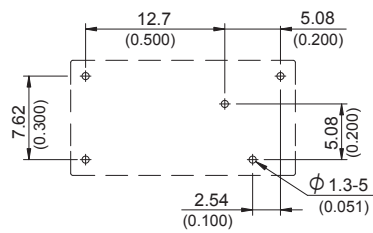

»» Engineering Data

