

Centrifugal Fans

direct driven
with scroll

Issue 1.3
November 2012

NICOTRA GEBHARDT-FAN.RU

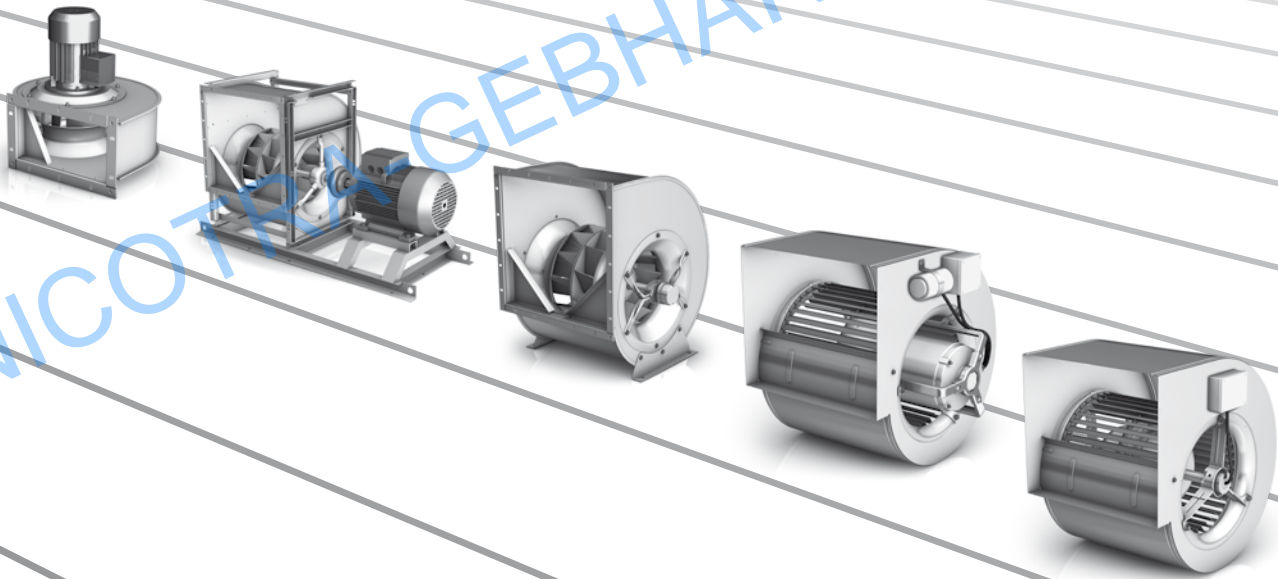

The overall picture will decide

Depending on the model of the fan, the efficiency grade "N" set in accordance with the ErP Directive must be achieved from 2013 and 2015 respectively.

Efficiency grade "N" to ErP-Directive

Year	Centrifugal fans with backward curved blades			Centrifugal fans with forward curved blades	
	without housing static	with housing static	total	with housing static	total
2013	≥ 0.50	≥ 0.55	≥ 0.50	≥ 0.50	≥ 0.50
2015	≥ 0.55	≥ 0.60	≥ 0.55	≥ 0.55	≥ 0.55

The efficiency grade designates a parameter in the calculation of the target energy efficiency of a fan depending on the electric input power when operating at the optimal energy efficiency point. The figure of parameter "N" corresponds to the target energy efficiency with a power of 10 kW.

To make the selection easier for our customers, we offer complete systems as defined by the ErP Directive!

In order to compare the systems, the total efficiency η_e of the fan without speed regulation is considered.

η_e = Total efficiency
 $P_{u(s)}$ = Fan gas power when operating at the optimal energy efficiency point
 P_e = Electric input power when operating at the optimal energy efficiency point

If the system has speed regulation, it will be taken into account with the "part load compensation factor" C_c (see below):

P_{ed} = Input power of speed regulator when operating at the optimal energy efficiency point
 C_c = part load compensation factor

- ▶ without speed regulation: $C_c = 1$
- ▶ with speed regulation $P_{ed} \geq 5$ kW: $C_c = 1.04$
- ▶ with speed regulation $P_{ed} < 5$ kW: $C_c = -0.03 \ln(P_{ed}) + 1.088$

In order to take the speed regulation into account via the part load compensation factor C_c , the following mathematical losses arise in accordance with the formula prescribed by ErP for the following typical motor powers:

- ▶ $P_{ed} = 4.00$ kW: $C_c = 1.05$ (5 %)
- ▶ $P_{ed} = 2.20$ kW: $C_c = 1.06$ (6 %)
- ▶ $P_{ed} = 0.75$ kW: $C_c = 1.10$ (10 %)

Complete systems by Nicotra Gebhardt

Nicotra Gebhardt can supply complete systems in all product categories which meet the ErP requirements. We offer highly efficient fan systems

- ▶ with matching components and "high efficiency drives" – belt and direct drive.
- ▶ with integrated or external control to regulate speed.
- ▶ with IEC standard motors (IE2) or internal rotor motors with brushless DC technology.
- ▶ and with AC external rotor motors or brushless DC external rotor motors.

Building blocks for best values





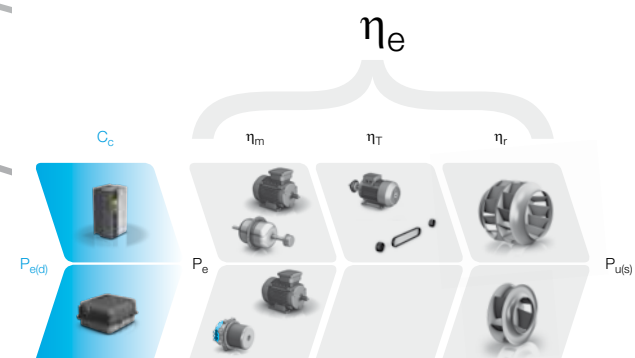

Thanks to the decades-long experience of Nicotra Gebhardt all the components of our fans contribute to their high performance.

Impellers and blades are optimised for turbulence and therefore particularly efficient. An example: With the latest development, the RLM Evo impeller, the free-running centrifugal fans of Nicotra Gebhardt achieve system efficiency grades never reached before.

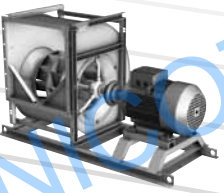
In addition, the brushless DC drives which Nicotra Gebhardt offers for its direct drive fans improve the system efficiency grades.

The fan technology of Nicotra Gebhardt delivers highly efficient systems for all applications.



	TEM/REM	RZM	RZP	RZA	DD	DDMB	DDM
							
	•	•	•	•	•	•	•
6.000 m³/h	•	•	•	•	•	•	•
10.000 m³/h	•	•	•	•	•	•	•
18.000 m³/h	•	•	•	•	•	•	•
35.000 m³/h	REM: 22.000 m³/h	•	•	•	•	•	•
100.000 m³/h	•	•	•	•	•	•	•
200.000 m³/h	•	•	•	•	•	•	•
40 °C	•	•	•	•	•	•	•
60 °C	•	•	•	•	•	•	•
80 °C	•	•	•	•	•	•	•
ATEX	•	•	•	•	•	•	•
Voltage	•	•	•	•	•	•	•
Brushless-DC	•	•	•	•	•	•	•
External Inverter	•	•	•	•	•	•	•
Forward curved blades galvanised sheet steel	TEM: •	•	•	•	•	•	•
Backward curved blades coated steel	REM: •	•	•	•	•	•	•
Galvanised steel	•	•	•	•	•	•	•
Coated steel	•	•	•	•	•	•	•
Single inlet	•	•	•	•	•	•	•
Double inlet	•	•	•	•	•	•	•
ErP status	•	•	•	•	•	•	•

MOTRA-GEBHARDT-FAN.RU

Flow rate

Media temperature

Speed control

Impeller

Casing material

Inlet type

Nicotra Gebhardt technologies like ...

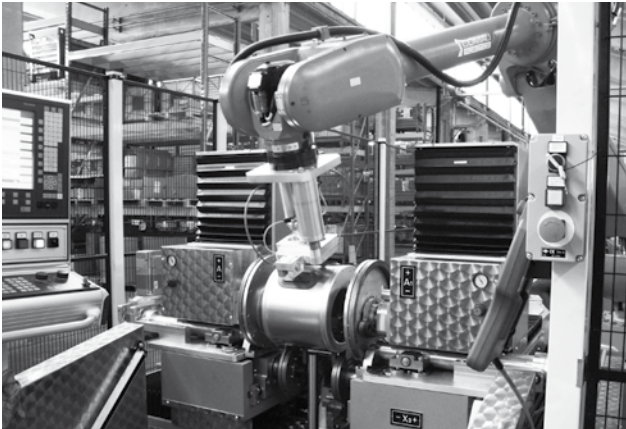

Automated manufacture of compact scroll and impeller with forward curved blades



Own AC and Brushless-DC motor production for optimal tuning of motor and fan!

proSELECTA II

proSELECTA II is a technical selection program that allows you to configure your own individually designed fan. It provides you with the opportunity to choose from the entire range of fan types and their associated options.

Simple and reliable selection

The result from proSELECTA II is the provision of all the technical data for your fan, including sound level data, dimension specifications and accessories. Apart from that, as a registered user, your purchase prices are provided. Additionally fully dimensioned drawings in dxf format are available, which can be downloaded and transferred straight into your CAD system.

So that you can be sure. Models and options that are technically not permissible, are automatically excluded in proSELECTA II. So there is no chance that you will configure a "wrong" device option.

You can register as a proSELECTA II user with us, which enables us to offer you faster order processing. What this means for you is:

- ▶ The complete configuration of your fan with its associated system accessories and belt drive layout.
- ▶ The possibility to produce fans that operate via a frequency inverter.
- ▶ The option of saving your own fan configuration on our server.
- ▶ The opportunity to modify your saved configuration, even over the phone to your Nicotra Gebhardt representative.



High performance centrifugal fans DDM

double width, double inlet, (DWDI),
with built-in, optimised external rotor motor,
made of galvanised sheet steel;
available in various models;
Impeller with forward curved blades of galvanised steel plate

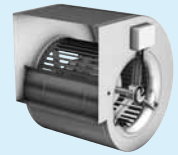
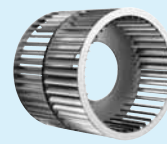

DDM

High performance centrifugal fans DDMB

double width, double inlet, (DWDI),
with built-in, brushless DC external rotor motor and external commutation unit,
made of galvanised sheet steel;
available in various models;
Impeller with forward curved blades of galvanised steel plate

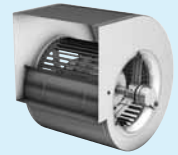
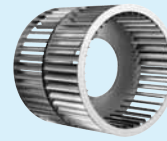

DDMB

High performance centrifugal fans DD

double width, double inlet, (DWDI),
built-in, optimised internal rotor motor,
made of galvanised sheet steel;
available in various models;
Impeller with forward curved blades of galvanised steel plate

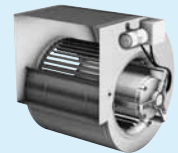
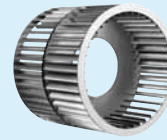

DD

High performance centrifugal fans RZA rotavent

double inlet,
with built-in, low-slip external rotor motor,
made of galvanised sheet steel or welded and coated,
with multi position feet and connecting flange at discharge;
Impeller with true aerofoil blades, welded and painted – system rotavent

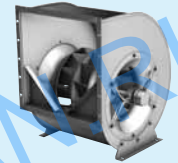

RZA

High performance centrifugal fans RZP rotavent

double inlet,
with built-in, brushless DC external rotor motor and external commutation unit,
made of galvanised sheet steel;
with multi position feet and connecting flange at discharge;
Impeller with true aerofoil blades, welded and painted – system rotavent

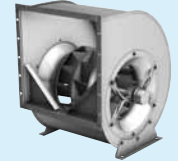

RZP

High performance centrifugal fans RZM rotavent

double inlet,
fan with directly coupled motor fitted on pedestal and base frame,
made of galvanised sheet steel with heavy duty reinforced side frame,
connecting flange at discharge,
Impeller with true aerofoil blades, welded and painted – system rotavent

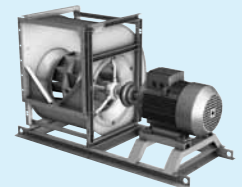

RZM

High performance centrifugal fans REM/TEM

single inlet, with flanged IEC standard motor out of air stream,
in unterschiedlichen Ausführungsvarianten,
Impeller with true aerofoil blades, welded and painted (REM)
or forward curved blades of galvanised steel plate (TEM),
with or without pedestal for horizontal or vertical mounting

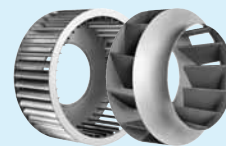
TEM
REM**Fittings / Accessories**

- ▶ complete system accessories
- ▶ fittings and options

Fittings
Accessories**Technical Description**

- ▶ Descriptions
- ▶ Operating limits
- ▶ Notes

Technical
Description

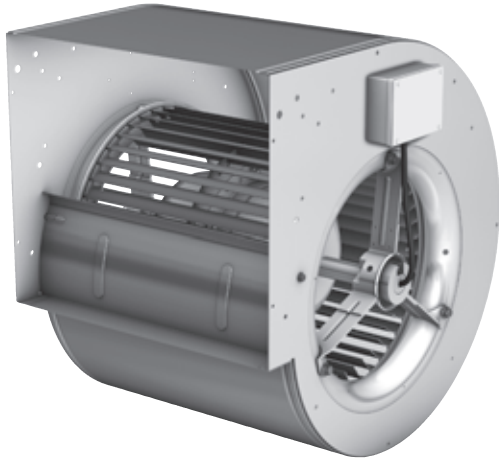

The best fan for your application!

DDM range – direct driven fans

Direct driven centrifugal fans of DDM range with forward curved impeller directly mounted on the external rotor motor are the ideal solution for your applications in the HVAC business.

The fact of manufacturing by ourselves each fan component – the casing, the impeller and motor – enables us to create fans that perfectly meet the requirements of high performances and low power consumptions.

The wide range of different versions and motor types allows you to find the fan exactly matching what you really need.

You anyway get the generally recognized advantages of the direct drive technology :

- **Maintenance free**
- **No transmission losses**
- **Long fan life time**
- **High reliability**
- **Low operating costs**

And, more, all the additional product advantages of the DDM range are at your fingertips.

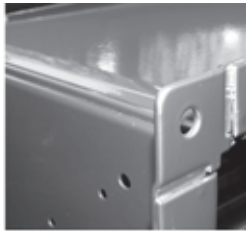

Compact casing

Aerodynamically optimized in terms of both airflow and design, scrolls are made of galvanized steel and automatically assembled using an innovative procedure, providing a sturdy and long-lasting product.

- **without welding points for no corrosion troubles**
- **high precision manufacturing process for high quality product**

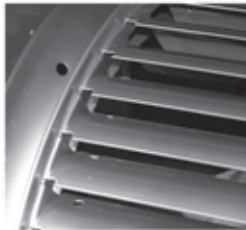

Real forward curved impeller

The impeller has been optimized for the best efficiency, match to the special motor features.

We manufacture the high performance impellers through a highly – automated and innovative production process.

- **low noise level**
- **low power consumption**



Optimized external rotor motor

The fan impeller is directly mounted on the motor thus providing efficient motor cooling by the fan airflow.

Motor speed can be adjusted either by the use of transformers and TRIAC regulators. Motors are generally fitted with thermal protector for protection against overheating.

- **high reliability and efficiency**
- **wide range of operative conditions**



Vibration isolation

The vibration isolation pads of the motor shaft ensures a very low noise during fan operation and no transmission of noise and vibrations to the other parts of the fan, making installation more quiet and comfortable.

- **low noise level**
- **no noise and vibrations transmitted to the surrounding structures**



Easy electrical connection

All fans could be provided with connection box, terminal block or loose cable.

A wiring diagram sticker, placed on each fan, describes the correct electrical connection.

- **fast and easy wiring**
- **safe operation**

NICOTRA | GEBHARDT | FAN.RU

Program overview:

DDM range

This kind of fans are specially conceived for use in dust-free environments, at temperatures up to +40°C, or higher on selected models. The performance data have been obtained in a laboratory registered by AMCA for AMCA 210/99 air performance testing. Data are not certified by AMCA.



Fan range DDM

- Impeller size (width and diameter) up to 15"
- Speed variation either by step-transformers or stepless
- External rotor motor with integrated thermal protector
- Fan models suitable for 60Hz supply are available
- Air Flow up to 12,000m³/h
- Static pressure up to 800Pa

The variety of DDM

We have the right fan for all your application!

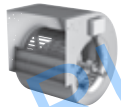
Many different sizes, versions and motor types are available in the DDM range.

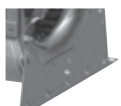
Version	Description	Figure
DDM	Lap-jointed scroll made from galvanized steel and forward curved blades impeller directly mounted on an external rotor motor.	
+SCT	with terminal box mounted	
+FL	with discharge flange mounted	
+SB	with housing feet either mounted or loose	

DDM-120/126

Technical Data

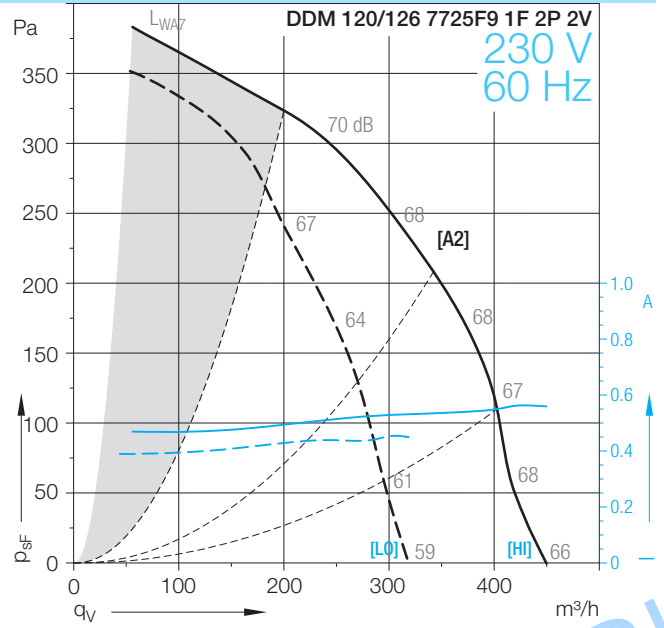
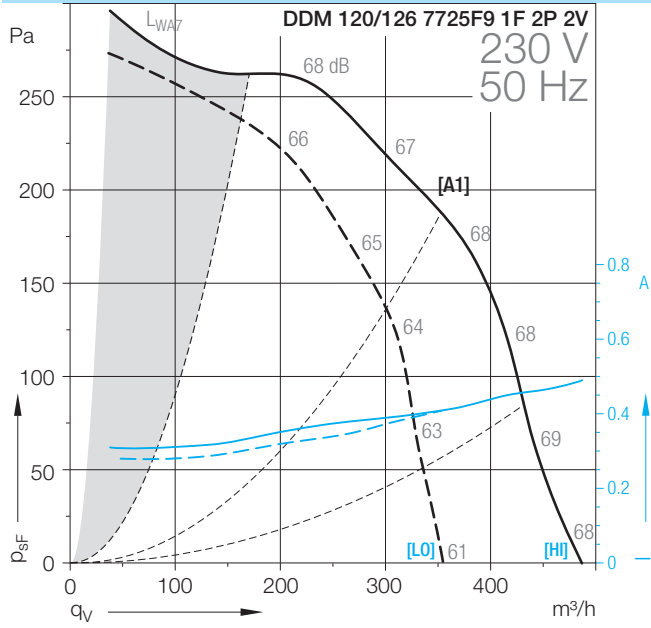

NICOTRA-GEBHARDT-FAN.RU

DDM-120/126

Technical Data										
	Speed control	Curves	Nominal motor power	Poles	Phases	Connection	Mains frequency	Max. power consumption	Max. current consumption	Speed
			W	-			Hz	W	A	1/min
DDM 120/126										
7725F9 1F 2P 2V	*	[A1/A2]	45	2	1~		50/60	113	0.5	2400

Technical Data										
	Operating Capacitor	Nominal capacitor voltage	Motor protection class	Motor thermal class	Thermal protection	Media Temperature max.	Fan weight	Density of media	Installation type (ISO 5801)	Article number
	µF	V				°C	kg	kg/m³		
DDM 120/126										
7725F9 1F 2P 2V	3.15	450	IP32	B	EXT	40	5	1.2	B	6M02010

- (1) = Speed controllable via Transformer
- (2) = Speed controllable via TRIAC or Transformer
- (3) = Speed controllable via Inverter
- * = No speed control available

[HI] High speed, [ME] Medium speed, [LO] Low speed
Attention! We suggest to do not use the fan in the grey marked area! The noise ratings given in the performance curves are sound power level L_{WA7} , see „Technical Description“.

Dimensions in mm, subject to change.

DDM 120/127 7725F9 1F 2P 2V

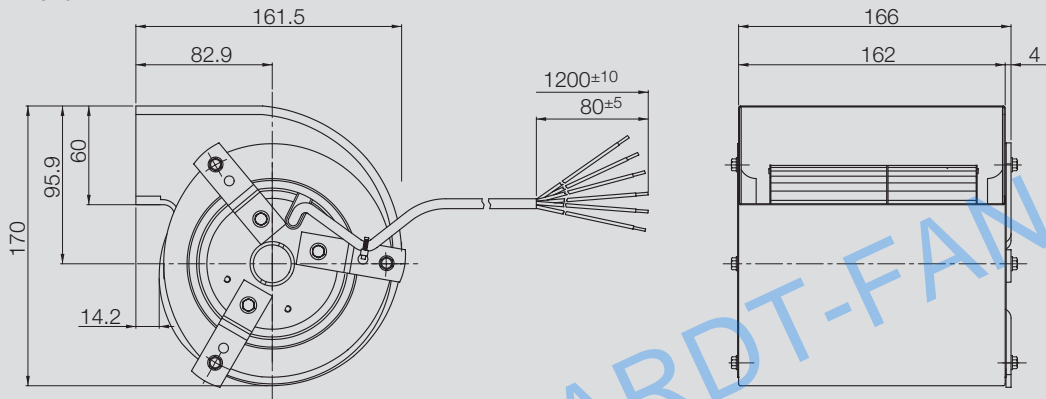

NICOTRA-GEBHARDT-FAN.RU

DDM-133/126

Technical Data

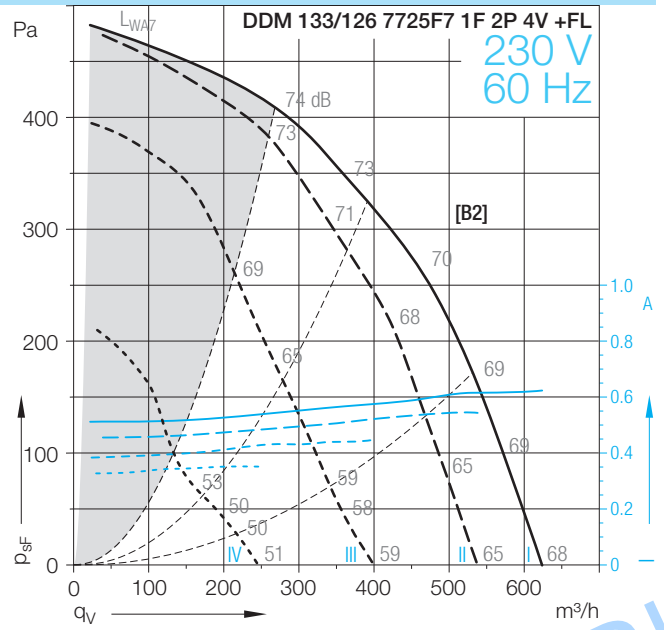
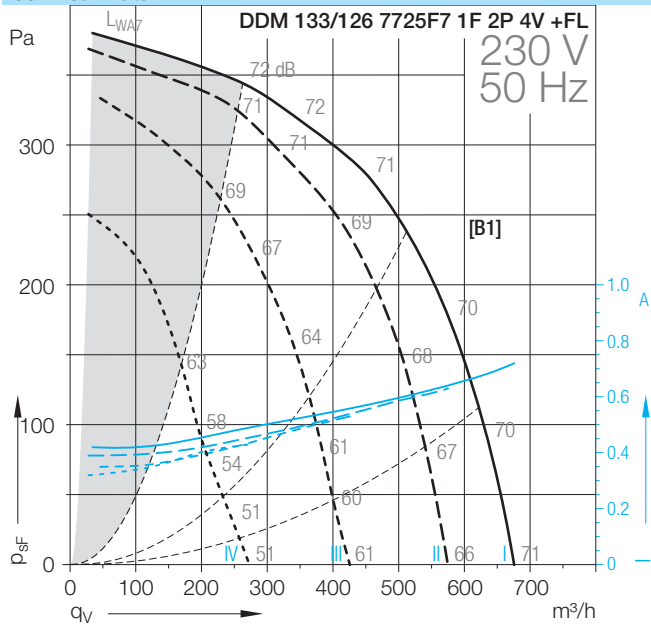

NICOTRA-GEBHARDT-FAN.RU

DDM-133/126

Technical Data										
	Speed control	Curves	Nominal motor power	Poles	Phases	Connection	Mains frequency	Max. power consumption	Max. current consumption	Speed
DDM 133/126			W	-			Hz	W	A	1/min
7725F7 1F 2P 4V +FL	*	[B1/B2]	60	2	1~		50/60	170	0.7	2500

Technical Data										
	Operating Capacitor	Nominal capacitor voltage	Motor protection class	Motor thermal class	Thermal protection	Media Temperature max.	Fan weight	Density of media	Installation type (ISO 5801)	Article number
DDM 133/126	μF	V				$^{\circ}\text{C}$	kg	kg/m³		
7725F7 1F 2P 4V +FL	4	450	IP32	B	INT	40	5	1.2	B	6M02097

- (1) = Speed controllable via Transformer
- (2) = Speed controllable via TRIAC or Transformer
- (3) = Speed controllable via Inverter
- * = No speed control available

[HI] High speed, [ME] Medium speed, [LO] Low speed
Attention! We suggest to do not use the fan in the grey marked area! The noise ratings given in the performance curves are sound power level L_{WA7} , see „Technical Description“.

Dimensions in mm, subject to change.
DDM 133/127 7725F7 1F 2P 4V +FL

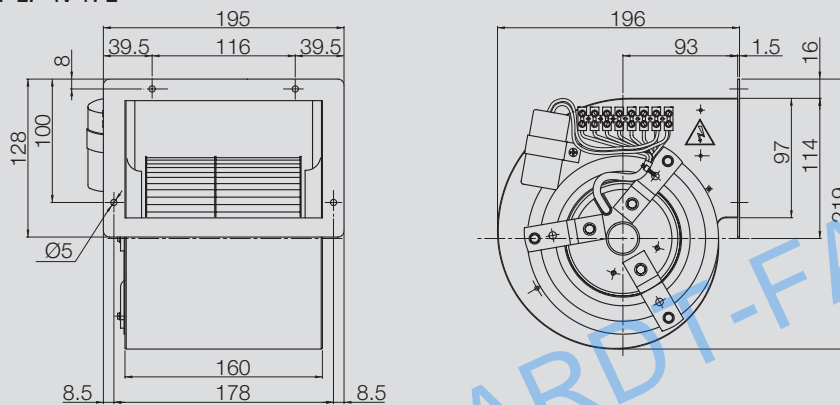

NICOTRA-GEBHARDT-FAN.RU

DDM-133/190

Technical Data

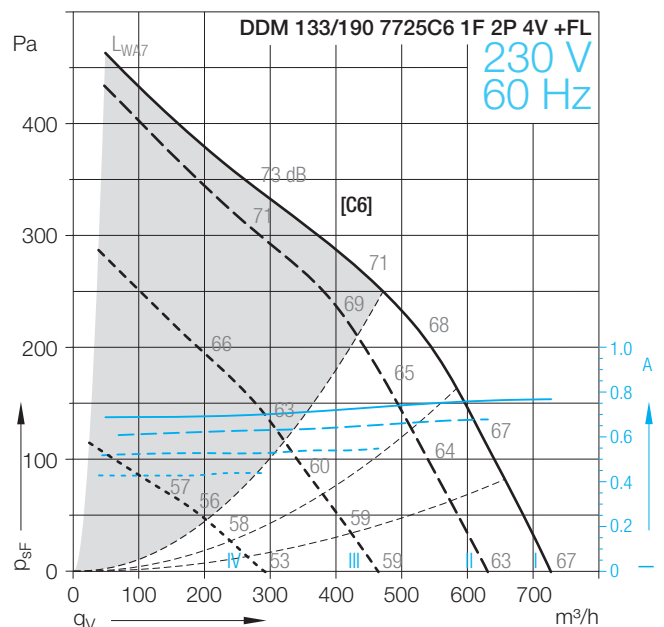
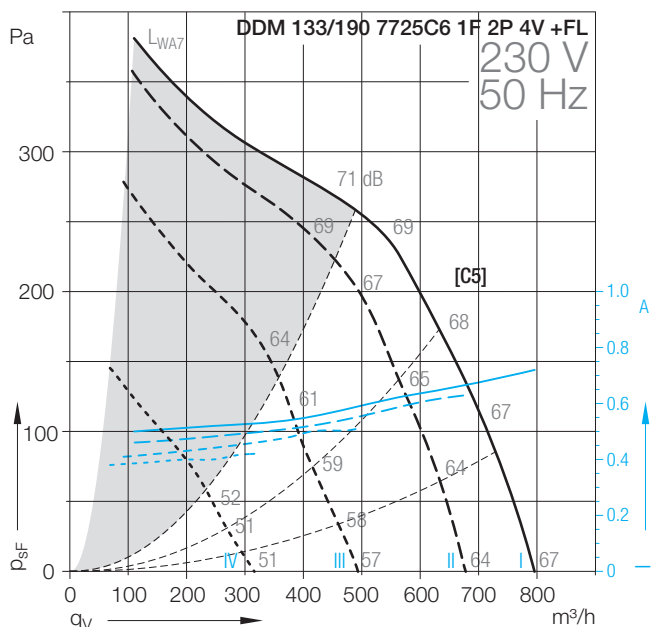
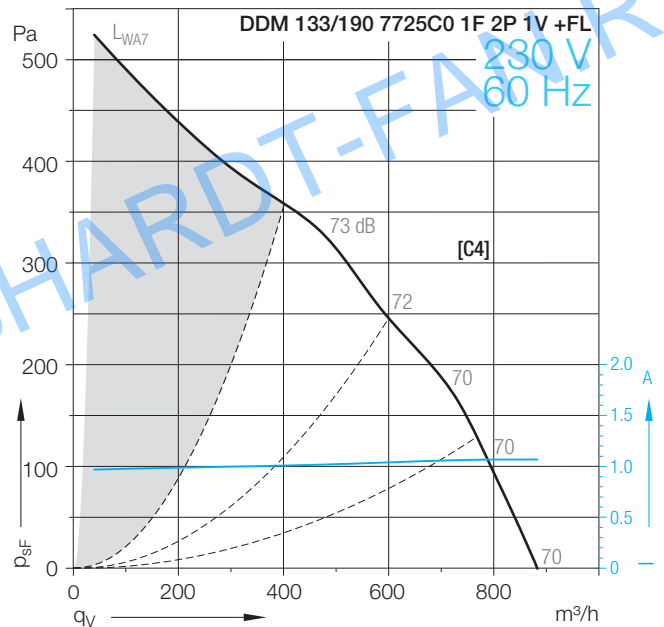
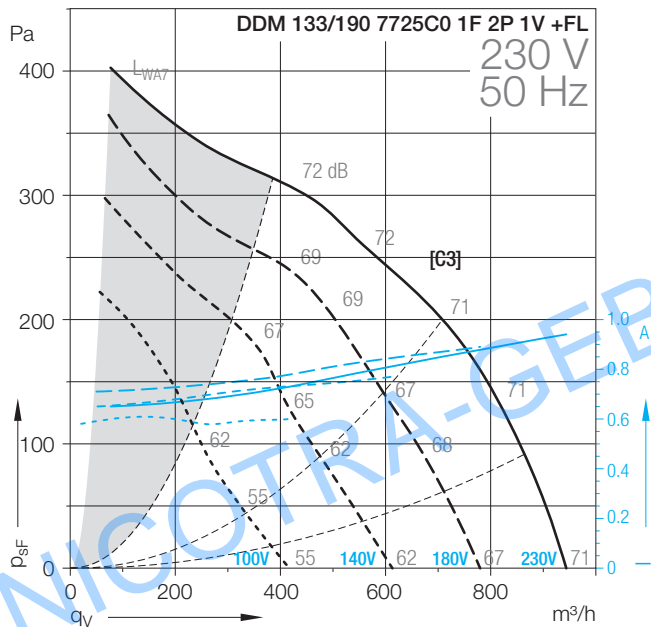
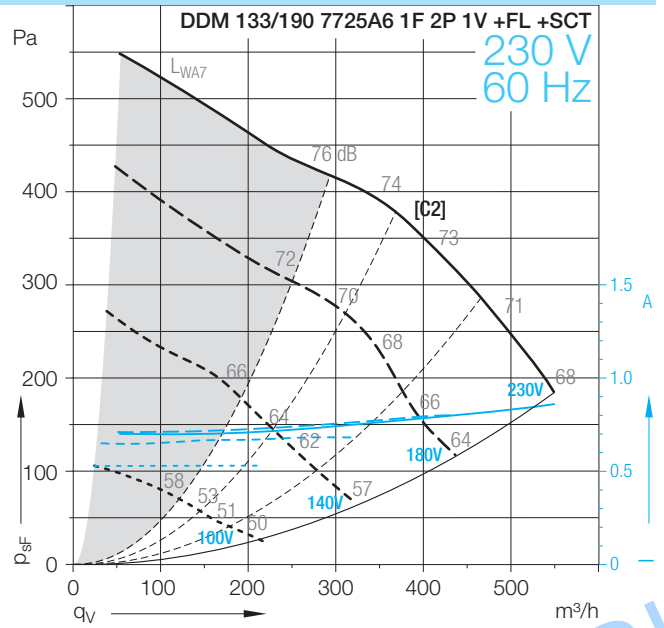
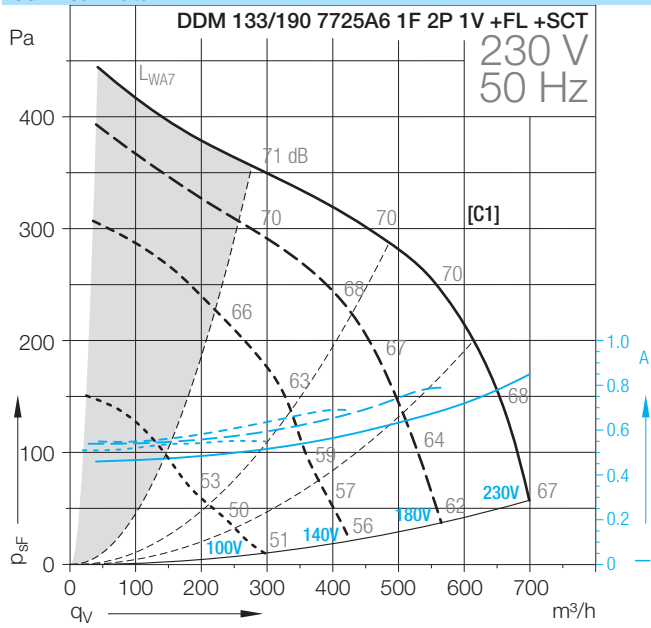

DDM-133/190

Technical Data

	Speed control	Curves	Nominal motor power	Poles	Phases	Connection	Mains frequency	Max. power consumption	Max. current consumption	Speed
DDM 133/190			W	-			Hz	W	A	1/min
7725A6 1F 2P 1V +FL	(2)	[C1/C2]	90	2	1~		50/60	202	0.9	2350
7725C0 1F 2P 1V +FL	(2)	[C3/C4]	90	2	1~		50/60	226	1	2300
7725C6 1F 2P 4V +FL	*	[C5/C6]	60	2	1~		50/60	175	0.7	2500

Technical Data

	Operating Capacitor	Nominal capacitor voltage	Motor protection class	Motor thermal class	Thermal protection	Media Temperature max.	Fan weight	Density of media	Installation type (ISO 5801)	Article number
DDM 133/190	μF	V				$^{\circ}\text{C}$	kg	kg/m³		
7725A6 1F 2P 1V +FL	4	450	IP54	F	INT	40	4	1.2	B	6102LT
7725C0 1F 2P 1V +FL	6.3	450	IP32	B	EXT	40	5	1.2	B	6102FW
7725C6 1F 2P 4V +FL	4	450	IP32	B	EXT	40	5	1.2	B	6102YC

(1) = Speed controllable via Transformer

(2) = Speed controllable via TRIAC or Transformer

(3) = Speed controllable via Inverter

* = No speed control available

[H] High speed, [ME] Medium speed, [LO] Low speed

Attention! We suggest to do not use the fan in the grey marked area! The noise ratings given in the performance curves are sound power level L_{WA7} , see „Technical Description“.

Dimensions in mm, subject to change.

DDM 133/190 7725A6 1F 2P 1V +FL

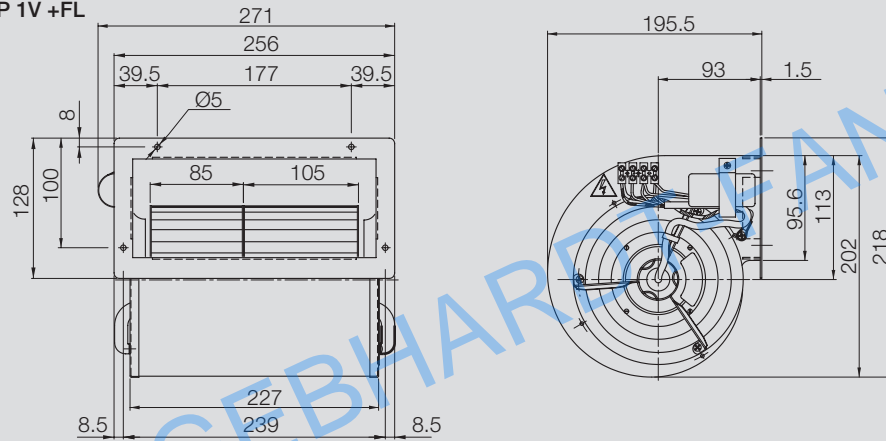

DDM 133/190 7725C0 1F 2P 1V +FL

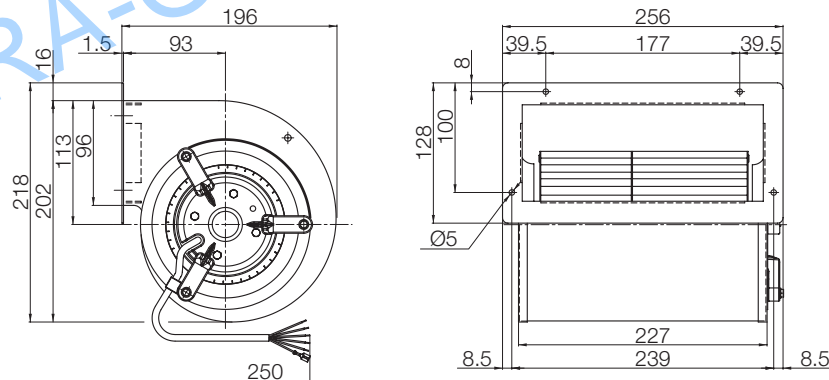

DDM 133/190 7725C6 1F 2P 4V +FL

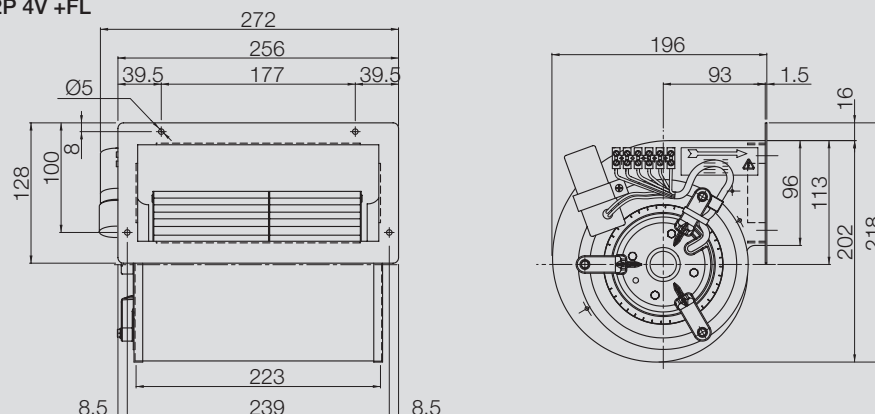

DDM-146/190

Technical Data

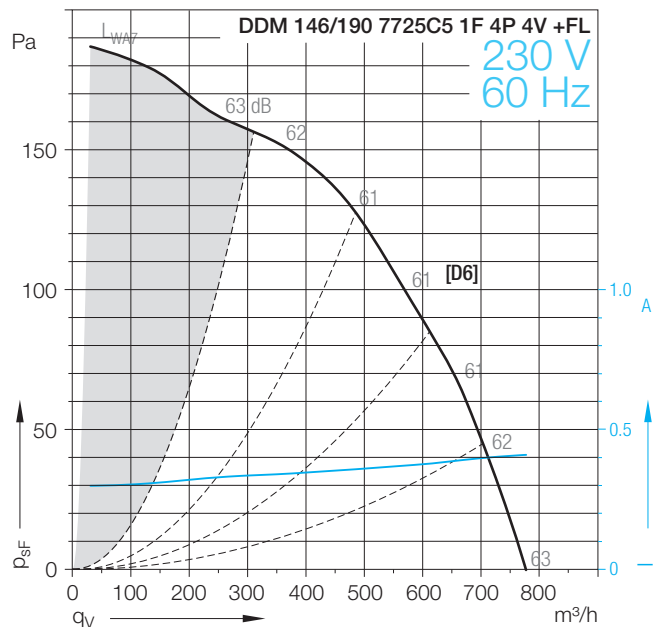
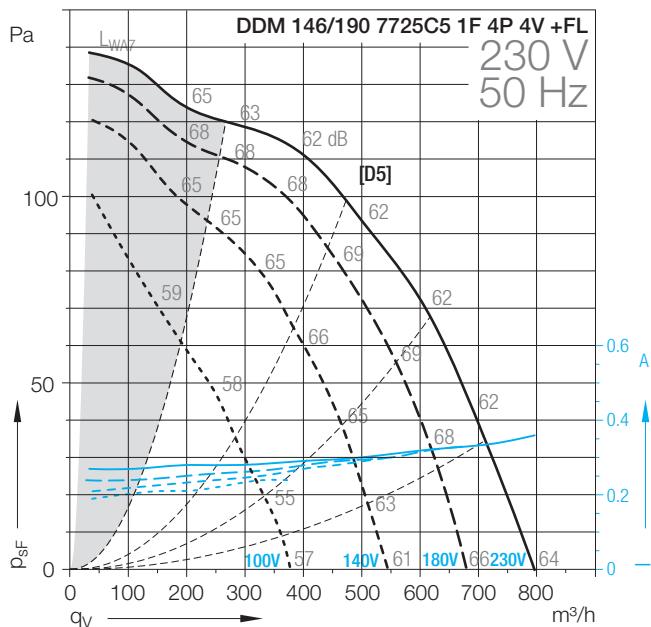
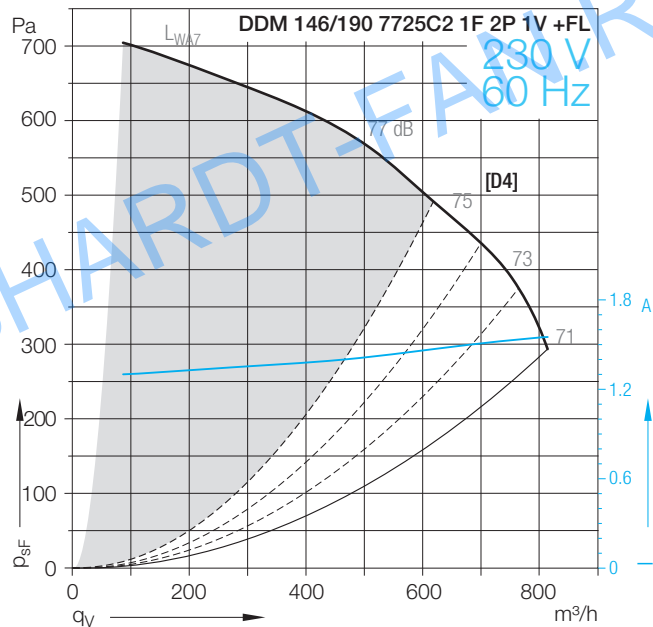
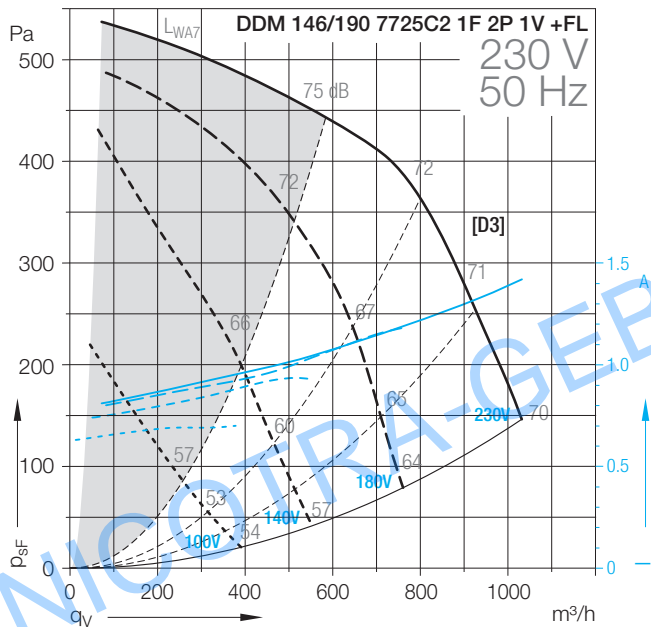
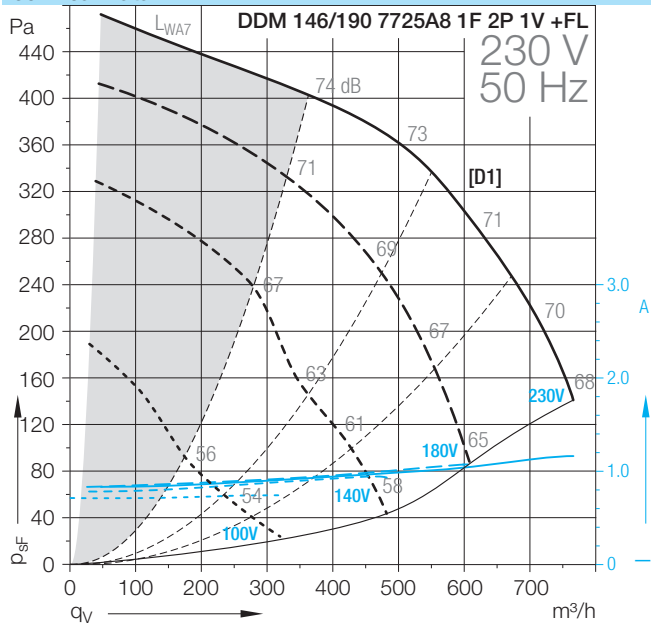

DDM-146/190

Technical Data										
	Speed control	Curves	Nominal motor power	Poles	Phases	Connection	Mains frequency	Max. power consumption	Max. current consumption	Speed
DDM 146/190			W	-			Hz	W	A	1/min
7725A8 1F 2P 1V +FL	(2)	[D1]	110	2	1~		50	274	1.1	2400
7725C2 1F 2P 1V +FL	(1)	[D3/D4]	160	2	1~		50/60	326	1.4	2200
7725C5 1F 4P 1V +FL	(2)	[D5/D6]	20	4	1~		50/60	84	0.4	1300

Technical Data										
	Operating Capacitor	Nominal capacitor voltage	Motor protection class	Motor thermal class	Thermal protection	Media Temperature max.	Fan weight	Density of media	Installation type (ISO 5801)	Article number
DDM 146/190	µF	V				°C	kg	kg/m³		
7725A8 1F 2P 1V +FL	5	450	IP54	F	INT	40	5	1.2	B	6102AZ
7725C2 1F 2P 1V +FL	10	450	IP32	F	EXT	40	7	1.2	B	6102YU
7725C5 1F 4P 1V +FL	2	450	IP32	B	INT	50	7	1.2	B	6102MH

- (1) = Speed controllable via Transformer
- (2) = Speed controllable via TRIAC or Transformer
- (3) = Speed controllable via Inverter
- * = No speed control available

[HI] High speed, [ME] Medium speed, [LO] Low speed
Attention! We suggest to do not use the fan in the grey marked area! The noise ratings given in the performance curves are sound power level L_{WA7} , see „Technical Description“.

Dimensions in mm, subject to change.

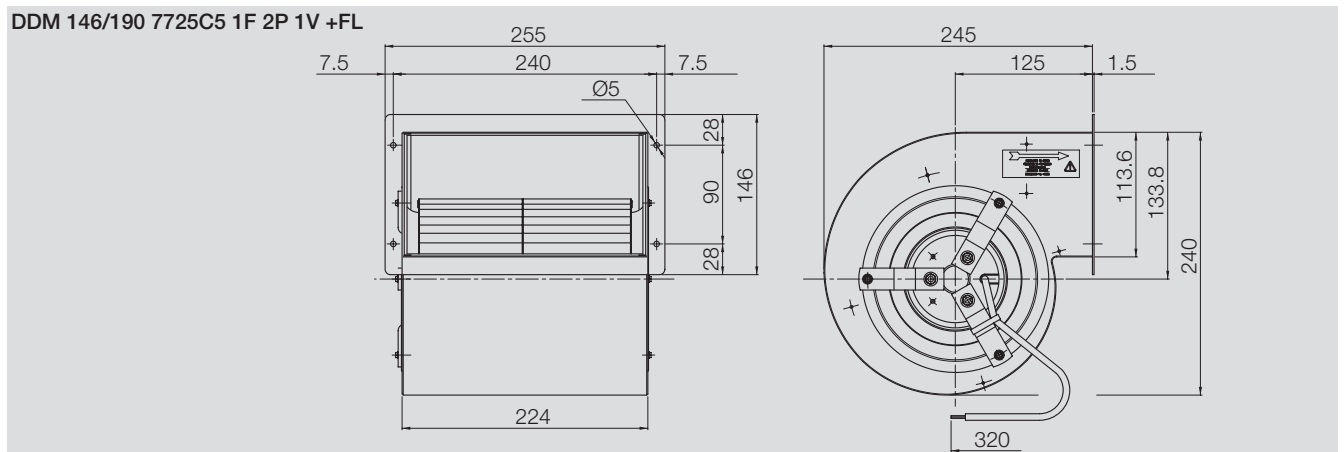
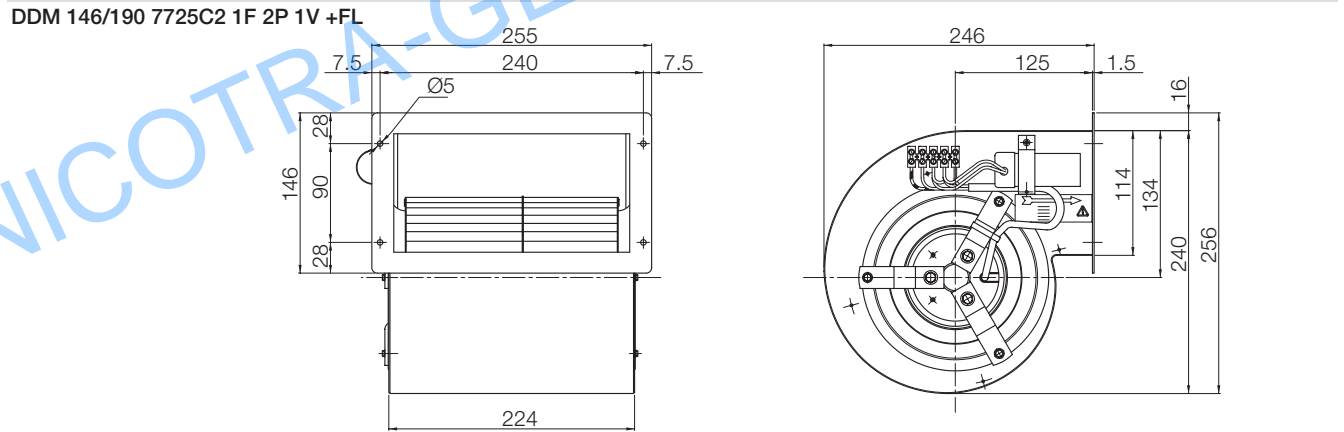
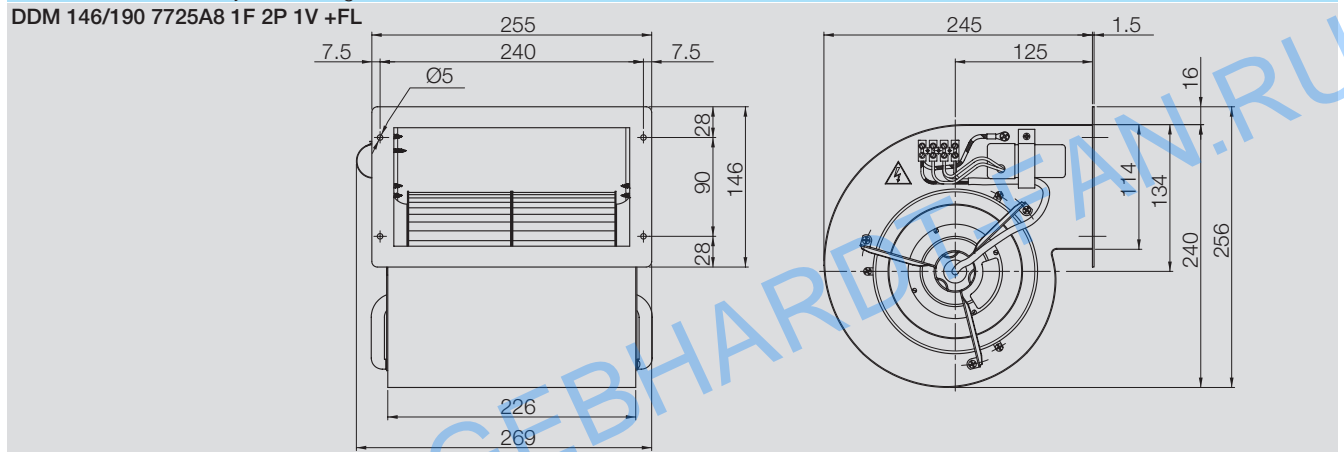

DDM-225/240

Technical Data

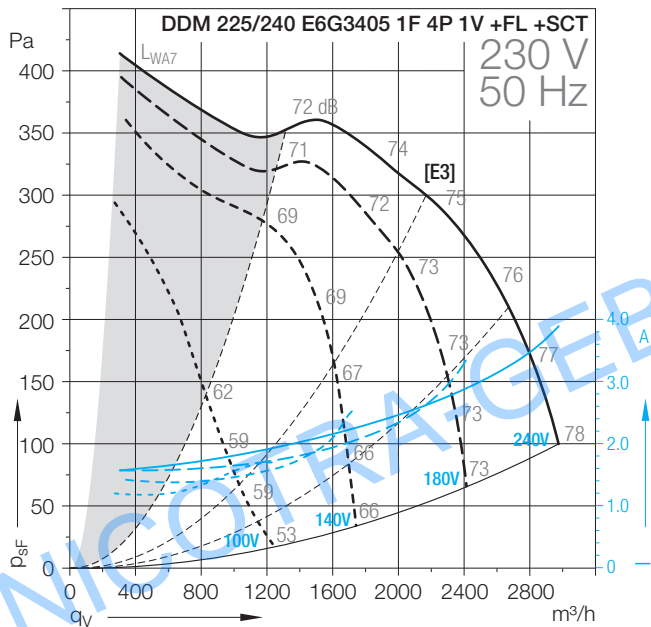
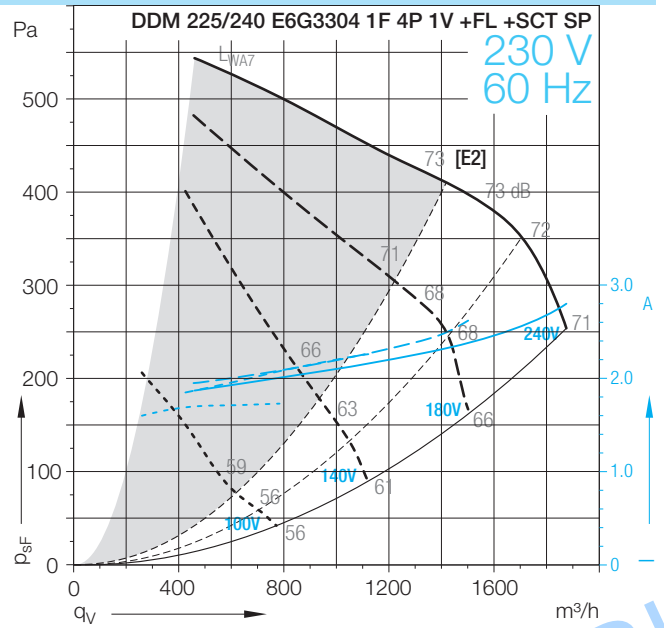
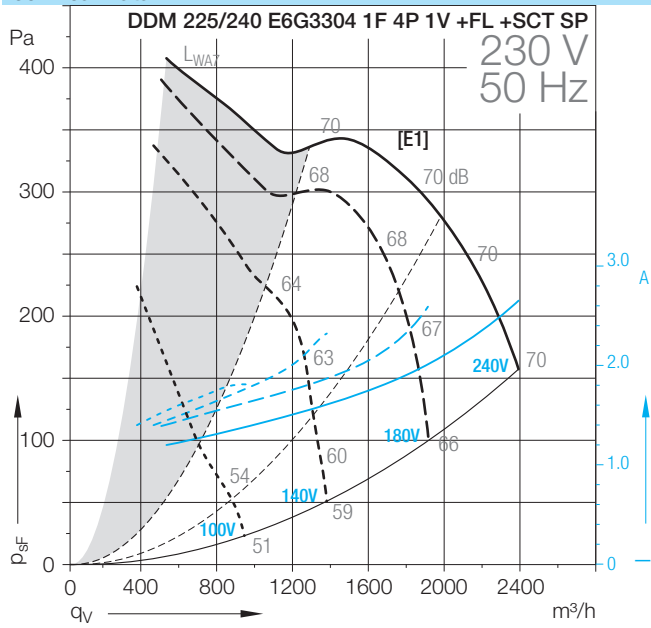

NICOTRA|GEBHARDT-FAN.RU

DDM-225/240

Technical Data										
	Speed control	Curves	Nominal motor power	Poles	Phases	Connection	Mains frequency	Max. power consumption	Max. current consumption	Speed
			W	-			Hz	W	A	1/min
DDM 225/240										
E6G3304 1F 4P 1V +FL +SCT SP	(2)	[E1/E2]	300	4	1~		50/60	633	2.6	1260
E6G3405 1F 4P 1V +FL +SCT	(2)	[E3/E4]	420	4	1~		50	910	3.9	1320

Technical Data										
	Operating Capacitor	Nominal capacitor voltage	Motor protection class	Motor thermal class	Thermal protection	Media Temperature max.	Fan weight	Density of media	Installation type (ISO 5801)	Article number
	µF	V				°C	kg	kg/m³		
DDM 225/240										
E6G3304 1F 4P 1V +FL +SCT SP	10	450	IP55	F	EXT	40	14	1.2	B	6102CT
E6G3405 1F 4P 1V +FL +SCT	16	450	IP55	F	EXT	40	14	1.2	B	6M02120

(1) = Speed controllable via Transformer

(2) = Speed controllable via TRIAC or Transformer

(3) = Speed controllable via Inverter

* = No speed control available

[HI] High speed, [ME] Medium speed, [LO] Low speed

Attention! We suggest to do not use the fan in the grey marked area! The noise ratings given in the performance curves are sound power level L_{WA7} , see „Technical Description“.

Dimensions in mm, subject to change.

DDM 225/240 E6G3304 1F 4P 1V +FL +SCT SP

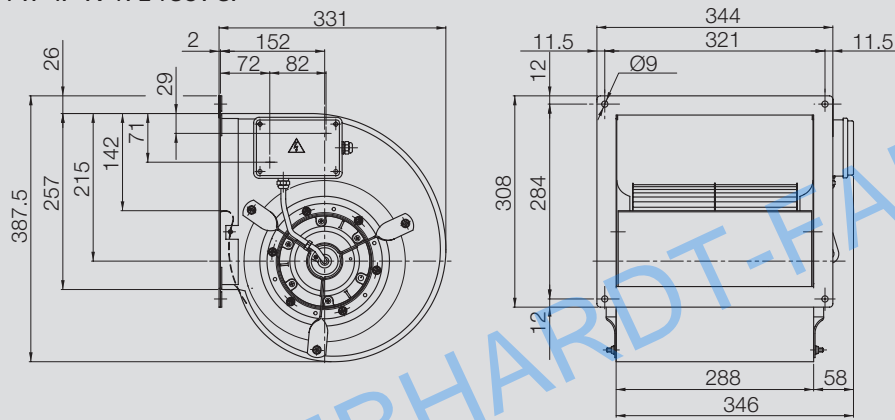

DDM 225/240 E6G3405 1F 4P 1V +FL +SCT

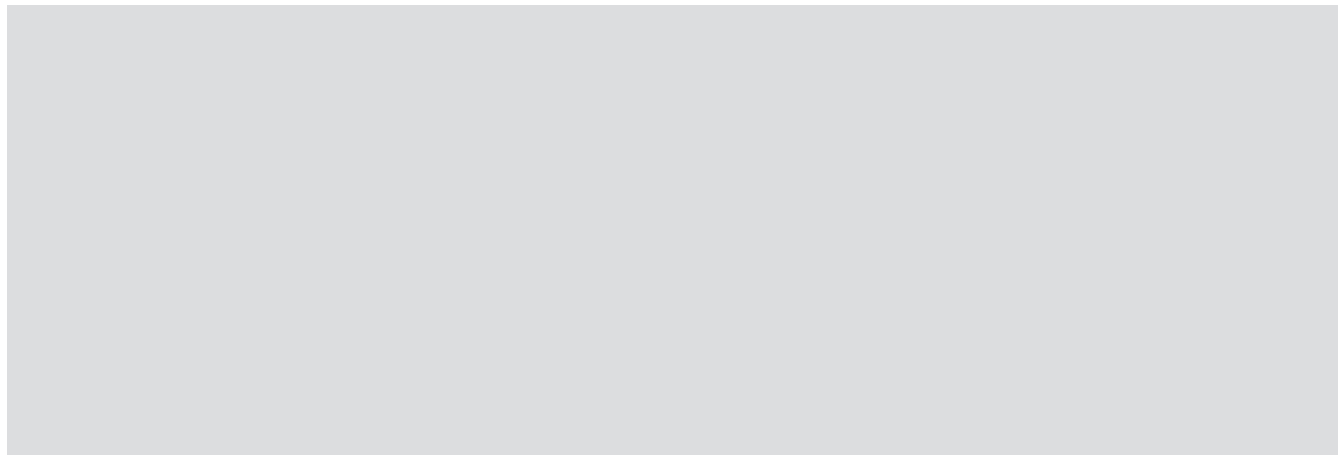
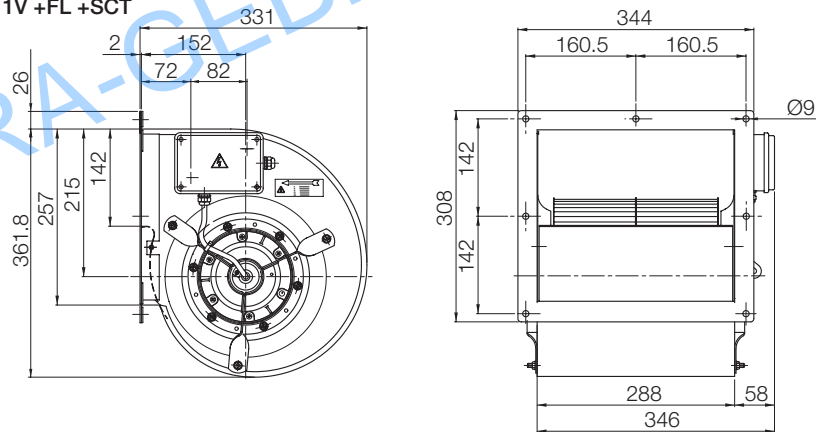

DDM-280/204

Technical Data

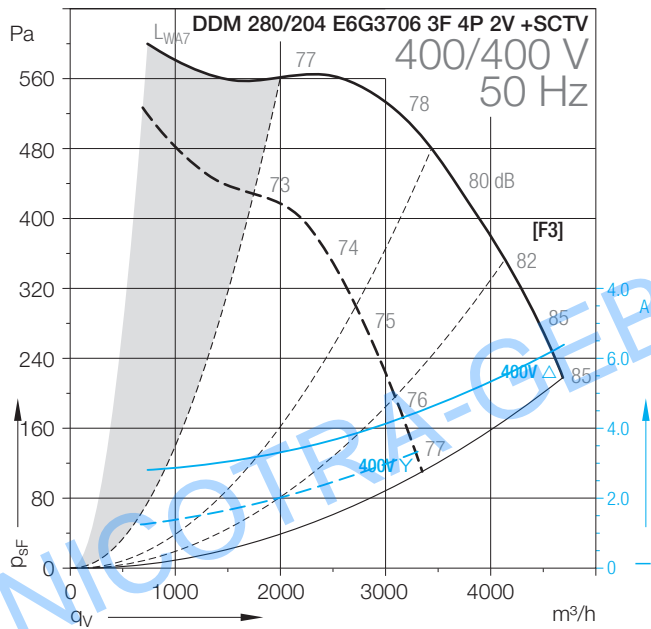
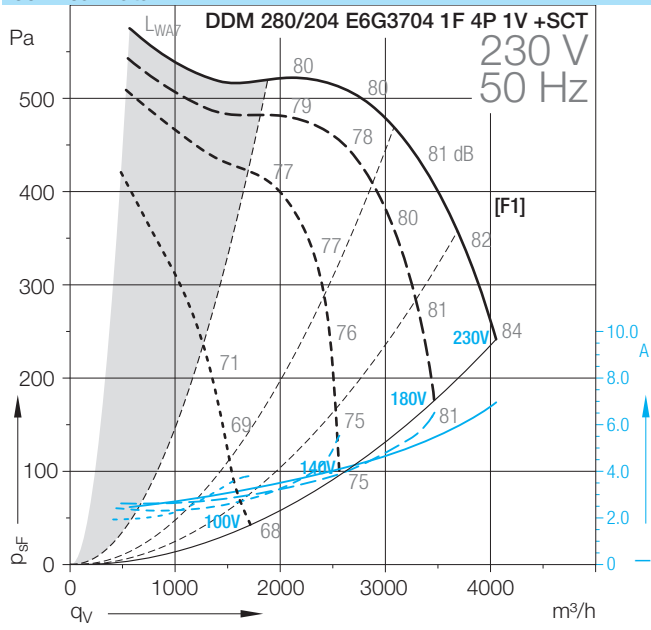

DDM-280/204

Technical Data										
DDM 280/204	Speed control	Curves	Nominal motor power	Poles	Phases	Connection	Mains frequency	Max. power consumption	Max. current consumption	Speed
			W	-			Hz	W	A	1/min
E6G3704 1F 4P 1V +SCT	(2)	[F1]	600	4	1~		50	1603	6.9	1380
E6G3706 3F 4P 1V +SCT	(1)	[F3]	750	4	3~	Δ/Y	50	1924	3.1	1370

Technical Data										
DDM 280/204	Operating Capacitor	Nominal capacitor voltage	Motor protection class	Motor thermal class	Thermal protection	Media Temperature max.	Fan weight	Density of media	Installation type (ISO 5801)	Article number
	μF	V				°C	kg	kg/m³		
E6G3704 1F 4P 1V +SCT	25	450	IP55	F	EXT	40	23	1.2	B	6102XE
E6G3706 3F 4P 1V +SCT			IP55	F	EXT	40	23	1.2	B	6M02121

(1) = Speed controllable via Transformer

(2) = Speed controllable via TRIAC or Transformer

(3) = Speed controllable via Inverter

* = No speed control available

[HI] High speed, [ME] Medium speed, [LO] Low speed

Attention! We suggest to do not use the fan in the grey marked area! The noise ratings given in the performance curves are sound power level L_{WA7} , see „Technical Description“.

Dimensions in mm, subject to change.

DDM 280/204 E6G3304 1F 4P 1V +SCT

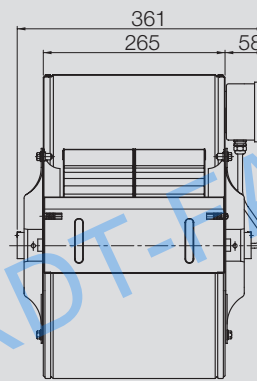
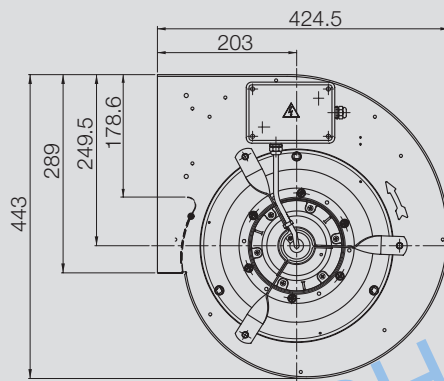

DDM 280/204 E6G3706 1F 4P 1V +SCT

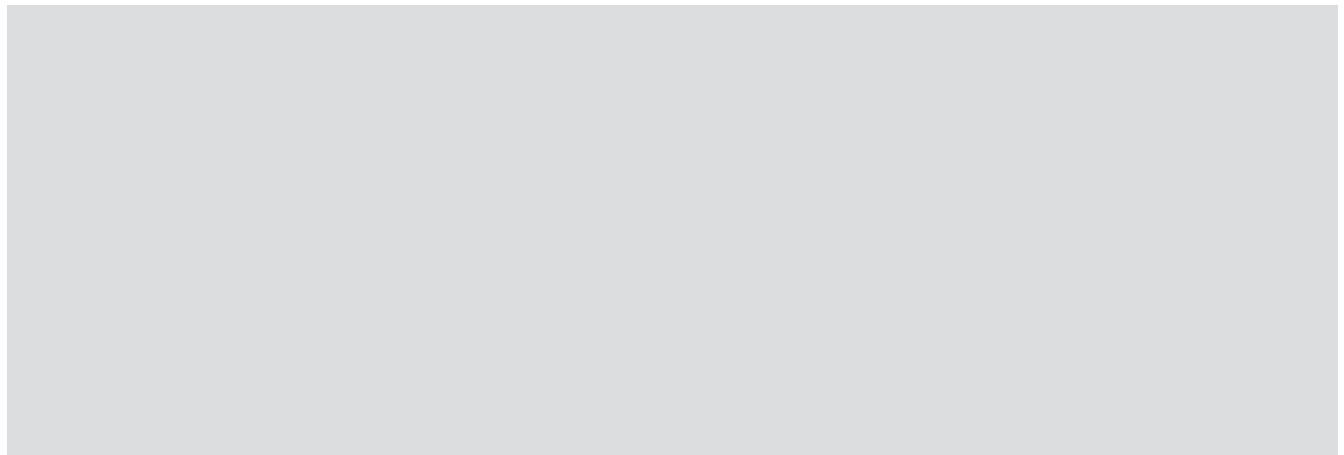
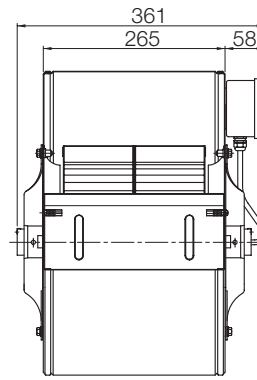
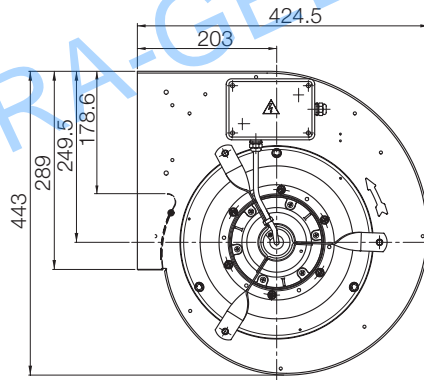

DDM-7/7

Technical Data

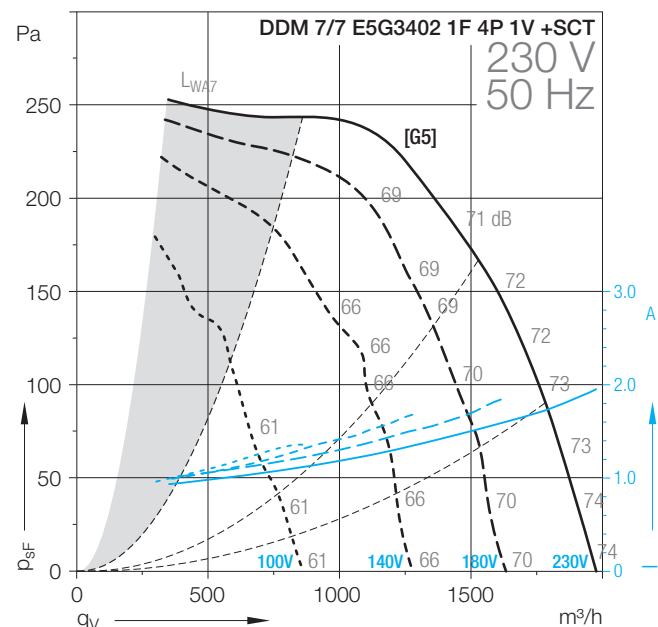
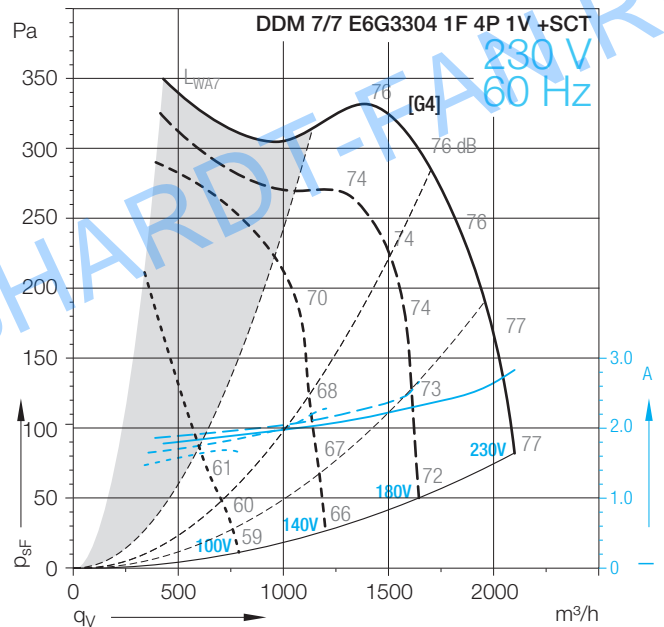
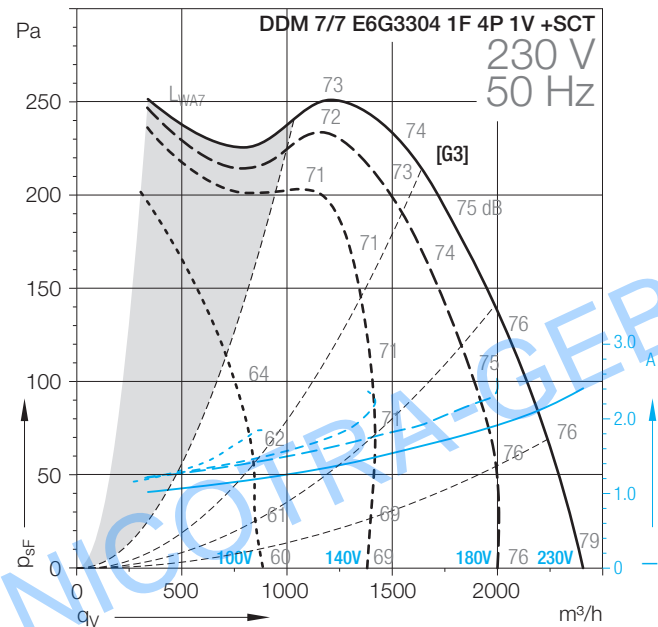
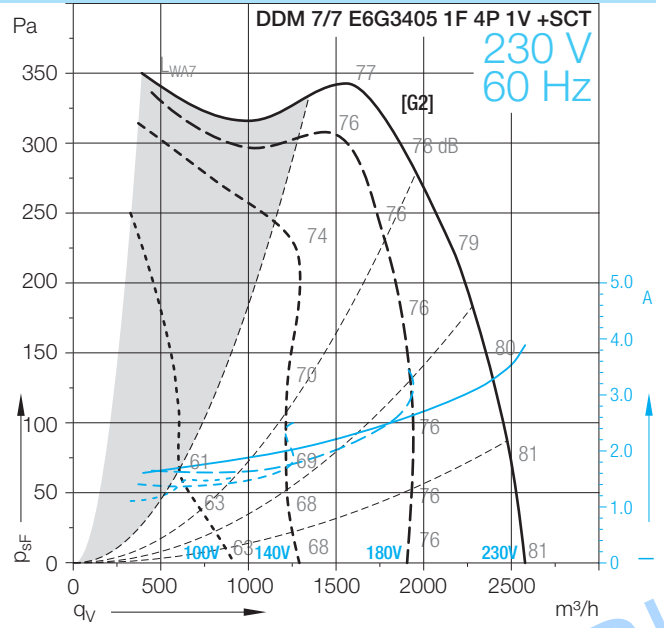
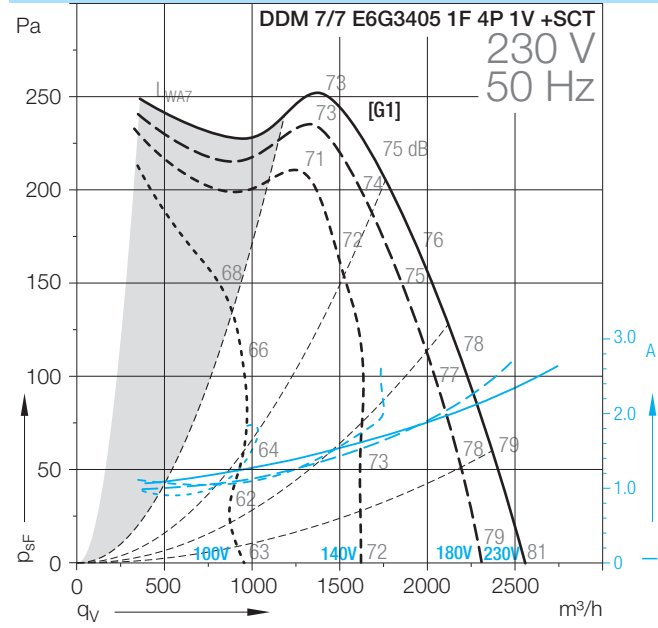

DDM-7/7

Technical Data										
	Speed control	Curves	Nominal motor power	Poles	Phases	Connection	Mains frequency	Max. power consumption	Max. current consumption	Speed
DDM 7/7			W	-			Hz	W	A	1/min
E6G3405 1F 4P 1V +SCT	(2)	[G1/G2]	420	4	1~		50/60	623	2.6	1320
E6G3304 1F 4P 1V +SCT	(2)	[G3/G4]	300	4	1~		50/60	555	2.3	1260
E5G3402 1F 4P 1V +SCT	(2)	[G5]	184	4	1~		50	458	1.9	1250

Technical Data										
	Operating Capacitor	Nominal capacitor voltage	Motor protection class	Motor thermal class	Thermal protection	Media Temperature max.	Fan weight	Density of media	Installation type (ISO 5801)	Article number
DDM 7/7	µF	V				°C	kg	kg/m³		
E6G3405 1F 4P 1V +SCT	12.5	450	IP55	F	EXT	50	12	1.2	B	6M02WL
E6G3304 1F 4P 1V +SCT	10	450	IP55	F	EXT	40	12	1.2	B	6M02Y8
E5G3402 1F 4P 1V +SCT	6.3	450	IP55	F	EXT	40	12	1.2	B	6M02L7

(1) = Speed controllable via Transformer

(2) = Speed controllable via TRIAC or Transformer

(3) = Speed controllable via Inverter

* = No speed control available

[H] High speed, [ME] Medium speed, [LO] Low speed

Attention! We suggest to do not use the fan in the grey marked area! The noise ratings given in the performance curves are sound power level L_{WA7} , see „Technical Description“.

Dimensions in mm, subject to change.

DDM 7/7 E6G3405 1F 4P 1V +SCT

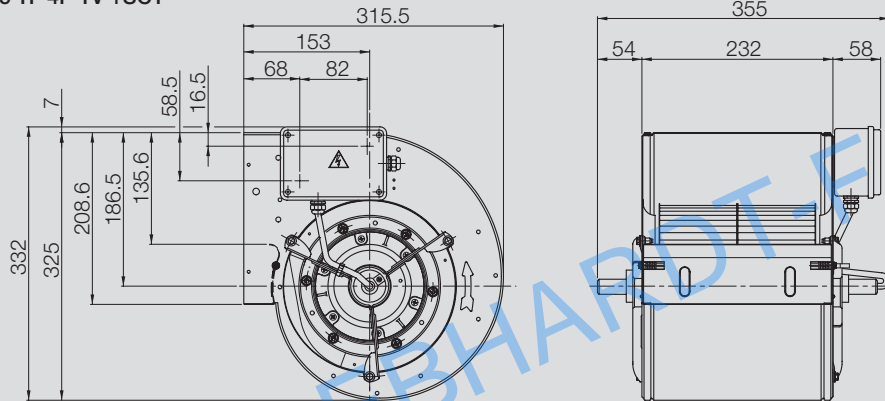

DDM 7/7 E6G3304 1F 4P 1V +SCT

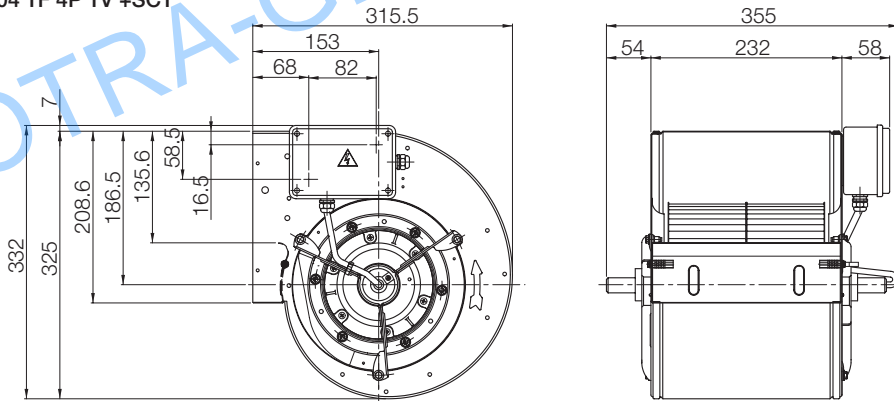

DDM 7/7 E5G3402 1F 4P 1V +SCT

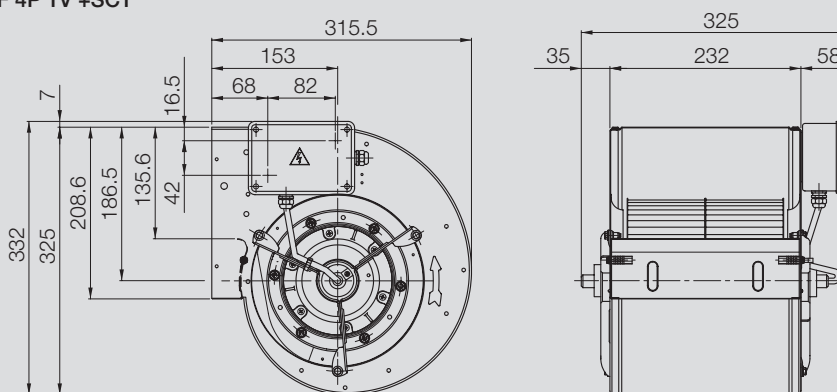

DDM-7/7

Technical Data

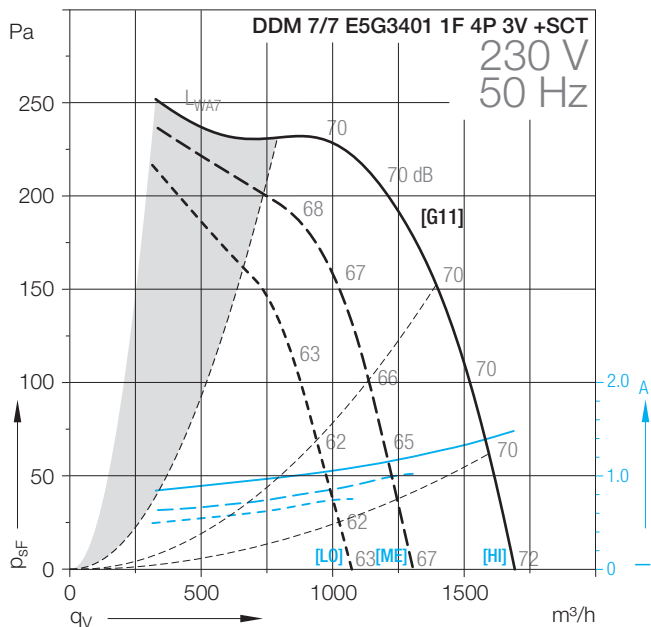
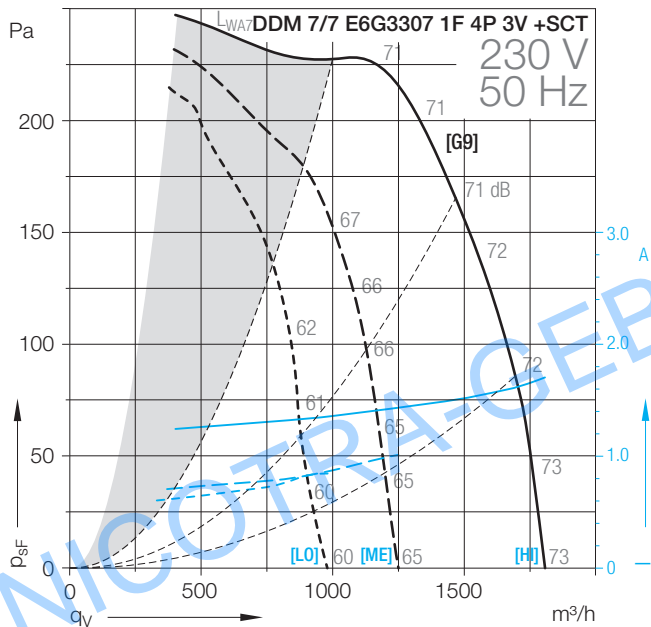
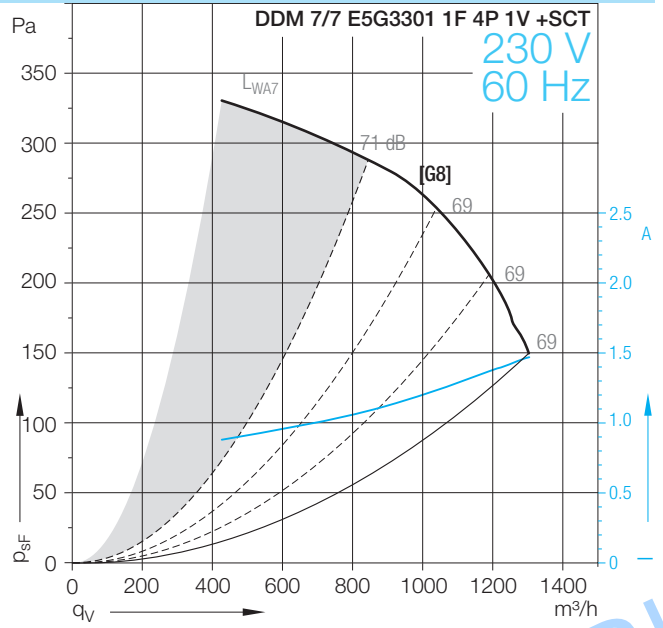
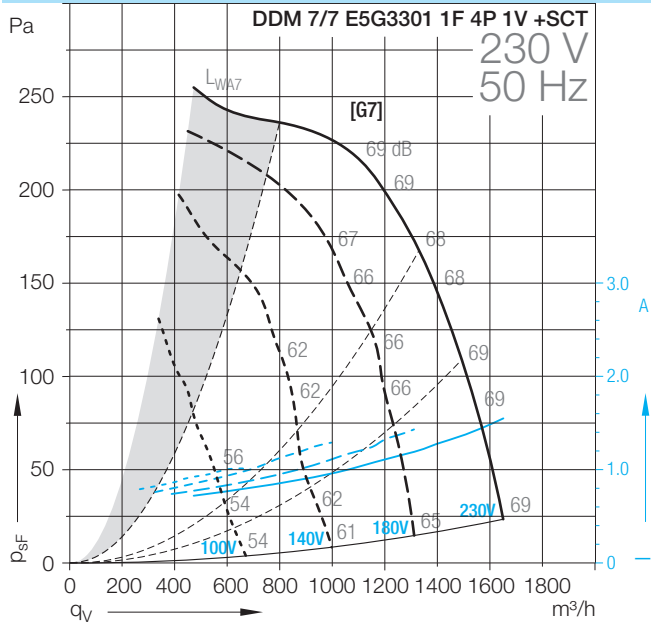

DDM-7/7

Technical Data										
	Speed control	Curves	Nominal motor power	Poles	Phases	Connection	Mains frequency	Max. power consumption	Max. current consumption	Speed
DDM 7/7			W	-			Hz	W	A	1/min
E5G3301 1F 4P 1V +SCT	(2)	[G7/G8]	147	4	1~		50/60	364	1.5	1200
E6G3307 1F 4P 3V +SCT	*	[G9]	184	4	1~		50	406	1.7	1230
E5G3401 1F 4P 3V +SCT	*	[G11]	147	4	1~		50	358	1.5	1150

Technical Data										
	Operating Capacitor	Nominal capacitor voltage	Motor protection class	Motor thermal class	Thermal protection	Media Temperature max.	Fan weight	Density of media	Installation type (ISO 5801)	Article number
DDM 7/7	µF	V				°C	kg	kg/m³		
E5G3301 1F 4P 1V +SCT	5	450	IP55	F	EXT	40	12	1.2	B	6M029M
E6G3307 1F 4P 3V +SCT	8	450	IP55	F	EXT	60	13	1.2	B	6M022U
E5G3401 1F 4P 3V +SCT	6.3	450	IP44	F	EXT	40	9	1.2	B	6M02U8

(1) = Speed controllable via Transformer

(2) = Speed controllable via TRIAC or Transformer

(3) = Speed controllable via Inverter

* = No speed control available

[H] High speed, [ME] Medium speed, [LO] Low speed

Attention! We suggest to do not use the fan in the grey marked area! The noise ratings given in the performance curves are sound power level L_{WA7} , see „Technical Description“.

Dimensions in mm, subject to change.

DDM 7/7 E5G3301 1F 4P 1V +SCT

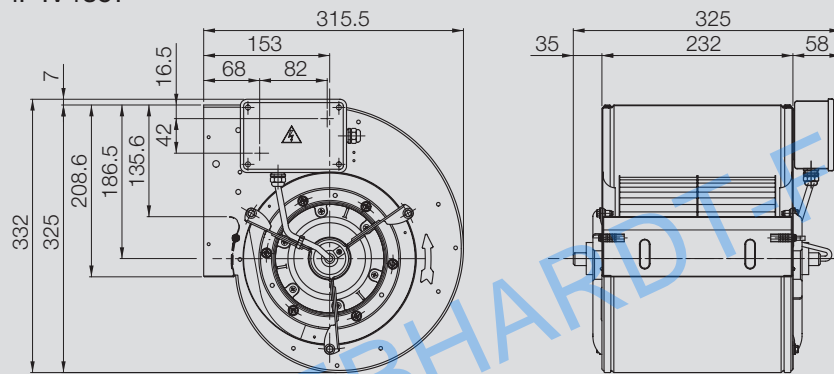

DDM 7/7 E6G3307 1F 4P 3V +SCT

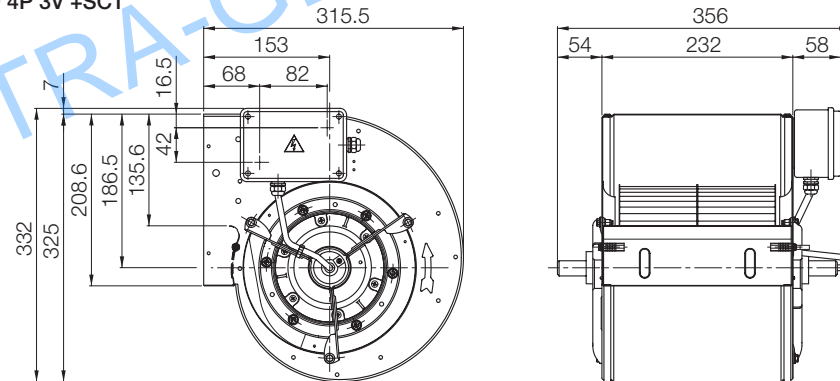

DDM 7/7 E5G3401 1F 4P 3V +SCT

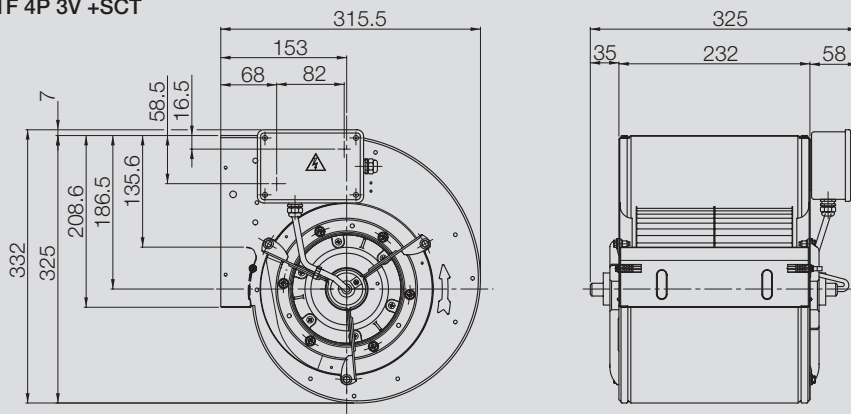

DDM-7/7

Technical Data

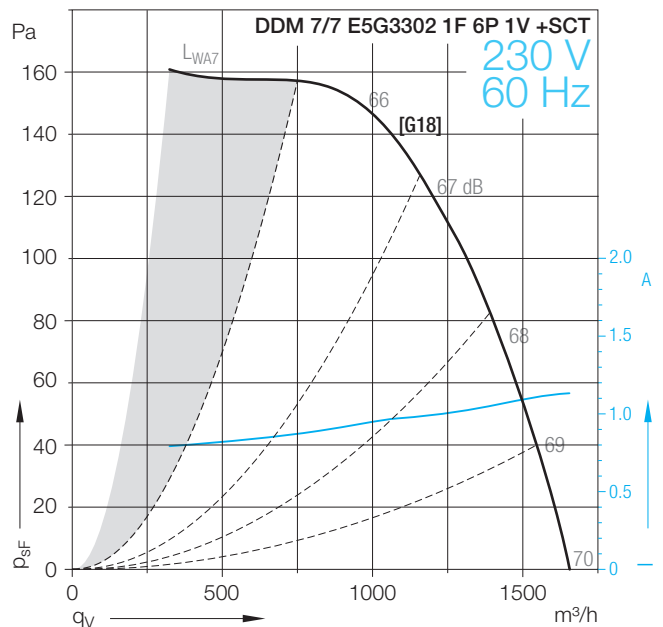
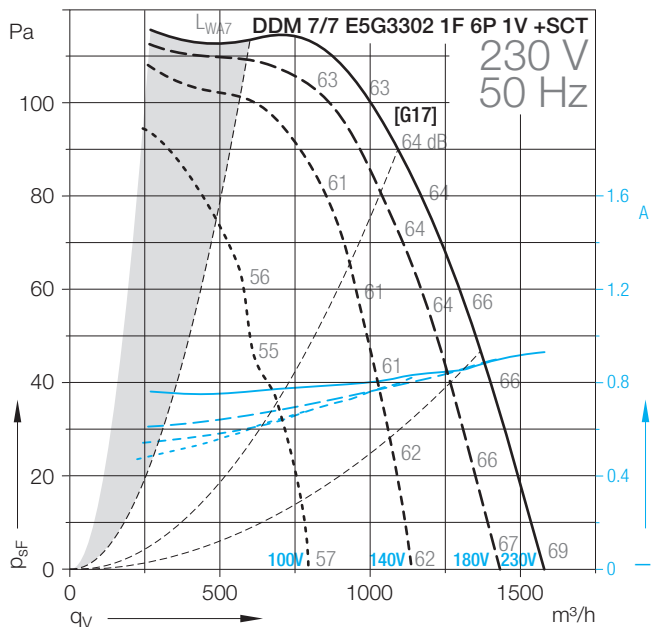
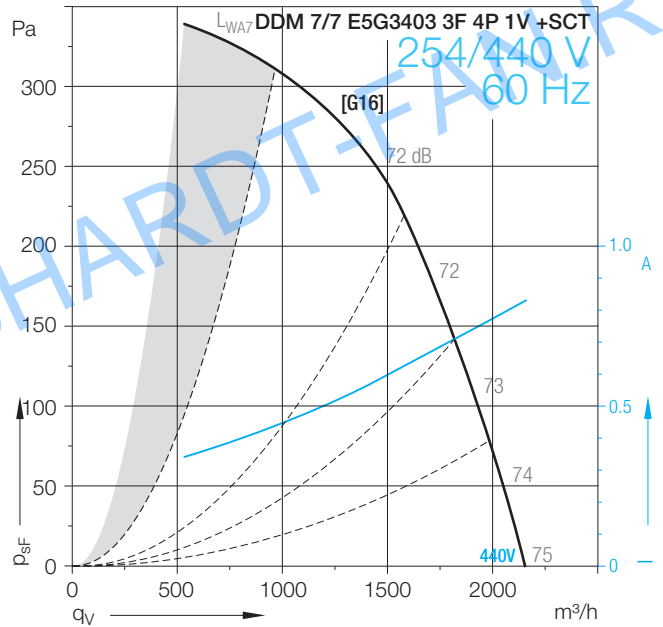
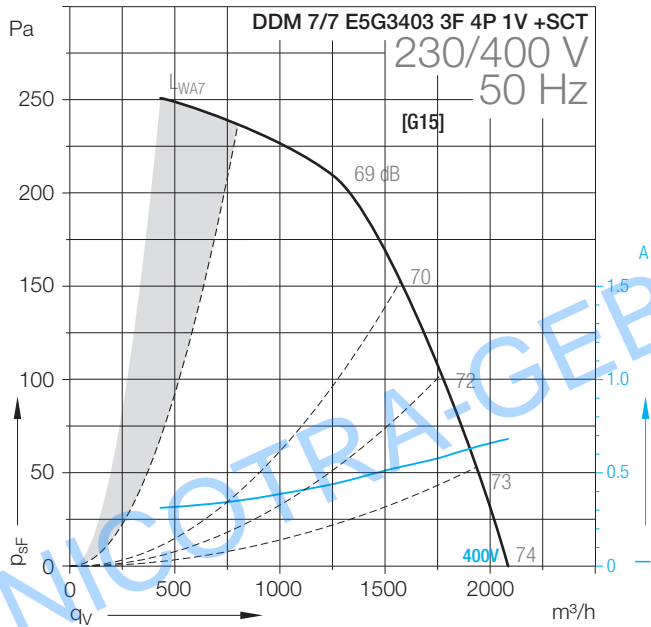
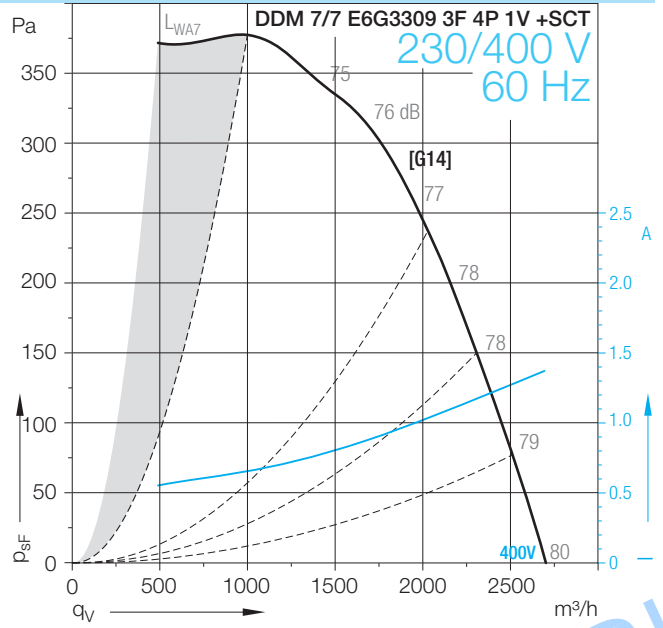
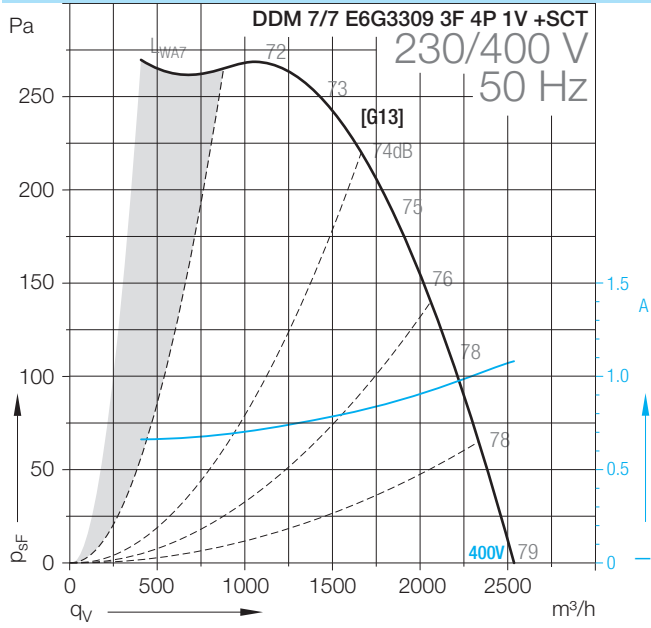

DDM-7/7

Technical Data										
	Speed control	Curves	Nominal motor power	Poles	Phases	Connection	Mains frequency	Max. power consumption	Max. current consumption	Speed
DDM 7/7			W	-			Hz	W	A	1/min
E6G3309 3F 4P 1V +SCT	*	[G13/G14]	300	4	3~	Δ/Y	50/60	605	1	1360
E5G3403 3F 4P 1V +SCT	*	[G15/G16]	147	4	3~	Δ/Y	50/60	413	0.7	1290
E5G3302 1F 6P 1V +SCT	(2)	[G17/G18]	90	6	1~		50/60	213	0.9	840

Technical Data										
	Operating Capacitor	Nominal capacitor voltage	Motor protection class	Motor thermal class	Thermal protection	Media Temperature max.	Fan weight	Density of media	Installation type (ISO 5801)	Article number
DDM 7/7	μF	V				°C	kg	kg/m³		
E6G3309 3F 4P 1V +SCT			IP55	F	EXT	70	15	1.2	B	6M02WM
E5G3403 3F 4P 1V +SCT			IP55	F	EXT	40	13	1.2	B	6M022H
E5G3302 1F 6P 1V +SCT	5	450	IP55	F	EXT	70	12	1.2	B	6M02Z4

- (1) = Speed controllable via Transformer
- (2) = Speed controllable via TRIAC or Transformer
- (3) = Speed controllable via Inverter
- * = No speed control available

[HI] High speed, [ME] Medium speed, [LO] Low speed
Attention! We suggest to do not use the fan in the grey marked area! The noise ratings given in the performance curves are sound power level L_{WA7} , see „Technical Description“.

Dimensions in mm, subject to change.

DDM 7/7 E6G3309 3F 4P 1V +SCT

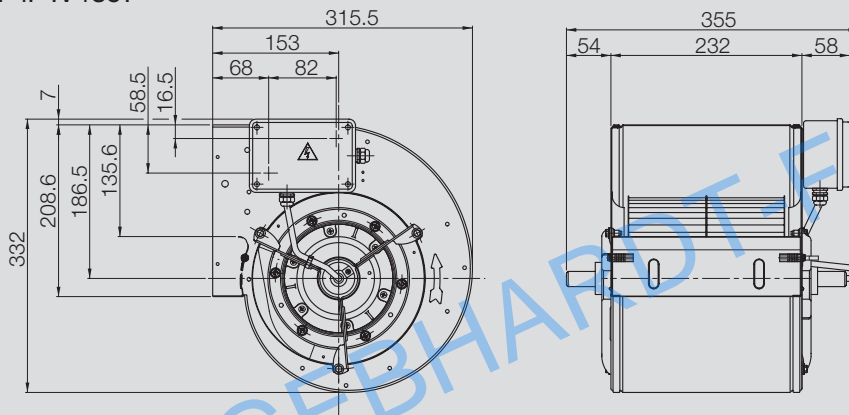

DDM 7/7 E5G3403 3F 4P 1V +SCT

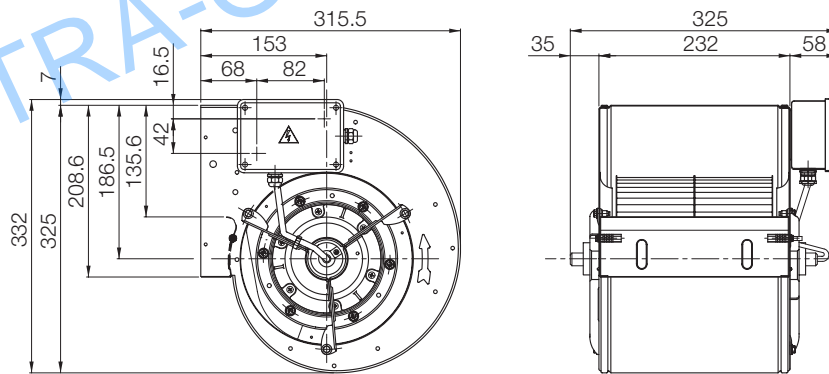

DDM 7/7 E5G3302 1F 6P 1V +SCT

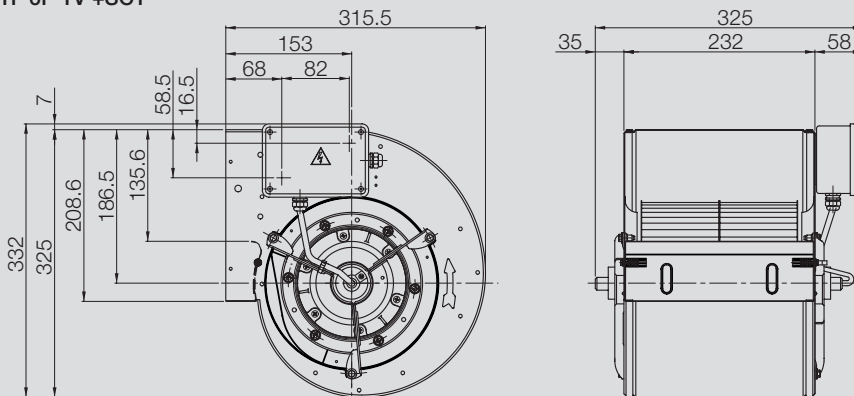

DDM-7/9

Technical Data

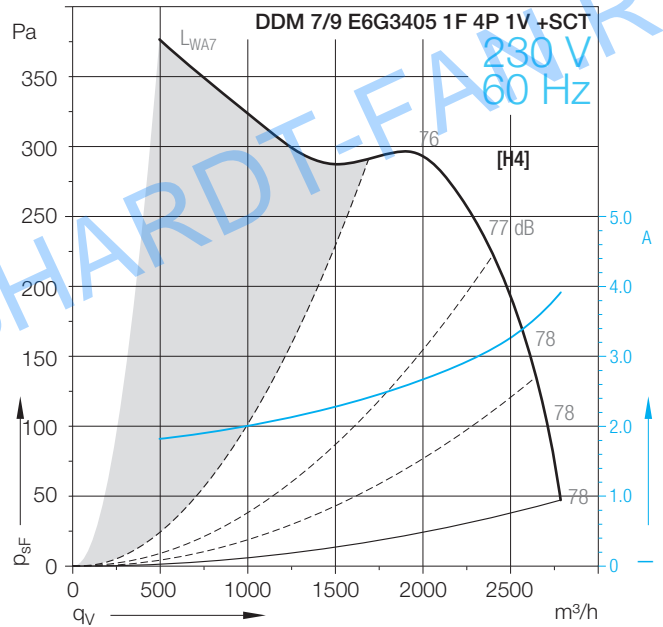
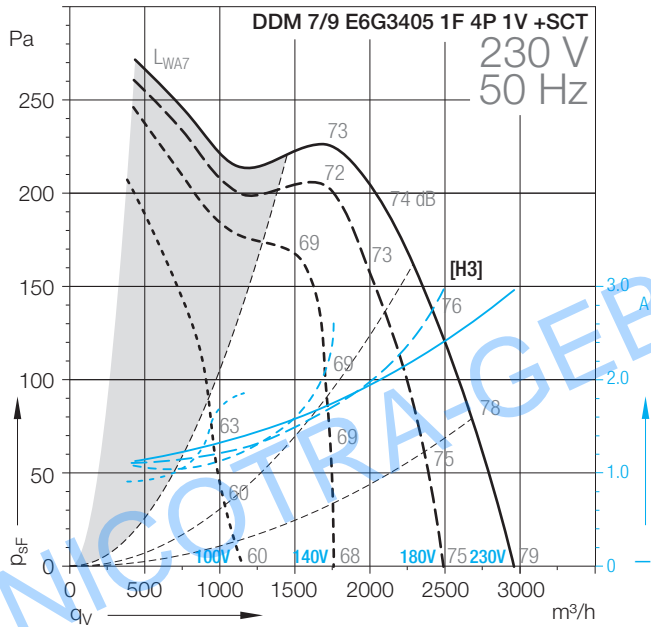
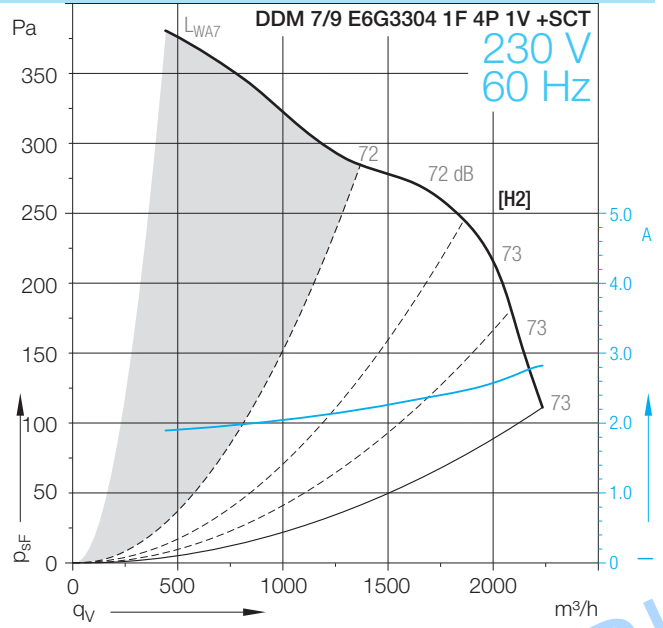
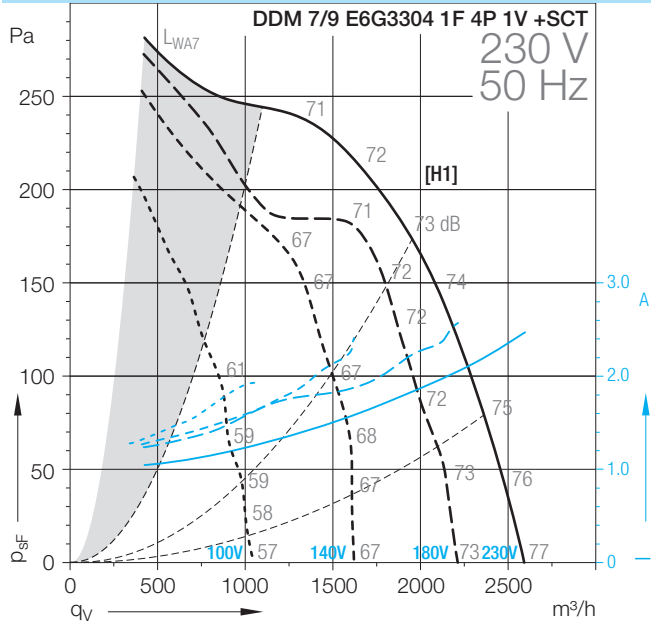

DDM-7/9

Technical Data										
	Speed control	Curves	Nominal motor power	Poles	Phases	Connection	Mains frequency	Max. power consumption	Max. current consumption	Speed
DDM 7/9			W	-			Hz	W	A	1/min
E6G3304 1F 4P 1V +SCT	(2)	[H1/H2]	300	4	1~		50/60	587	2.4	1260
E6G3405 1F 4P 1V +SCT	(2)	[H3/H4]	420	4	1~		50/60	696	3	1320

Technical Data										
DDM 7/9	Operating Capacitor	Nominal capacitor voltage	Motor protection class	Motor thermal class	Thermal protection	Media Temperature max.	Fan weight	Density of media	Installation type (ISO 5801)	Article number
	µF	V				°C	kg	kg/m³		
E6G3304 1F 4P 1V +SCT	10	450	IP55	F	EXT	40	15	1.2	B	6M02L6
E6G3405 1F 4P 1V +SCT	12.5	450	IP55	F	EXT	40	15	1.2	B	6M025X

(1) = Speed controllable via Transformer

(2) = Speed controllable via TRIAC or Transformer

(3) = Speed controllable via Inverter

* = No speed control available

[HI] High speed, [ME] Medium speed, [LO] Low speed

Attention! We suggest to do not use the fan in the grey marked area! The noise ratings given in the performance curves are sound power level L_{WA7} , see „Technical Description“.

Dimensions in mm, subject to change.

DDM 7/9 E6G3304 1F 4P 1V +SCT

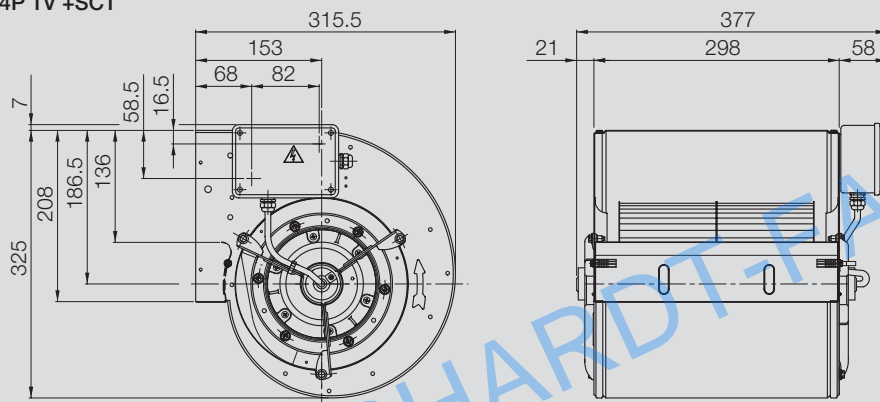

DDM 7/9 E6G3405 1F 4P 1V +SCT

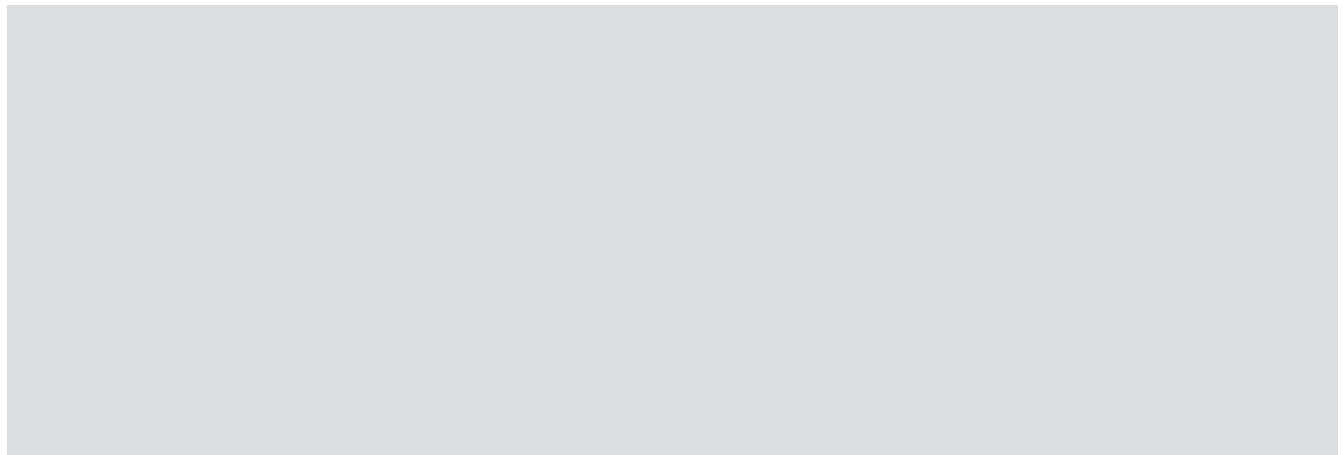
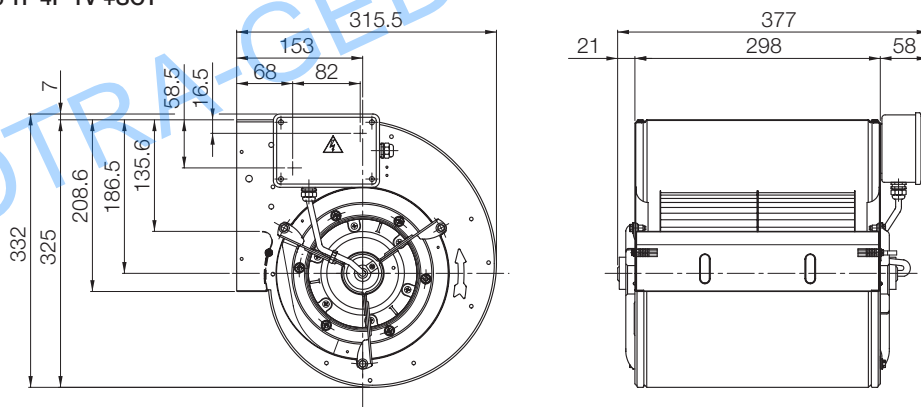

DDM-9/7

Technical Data

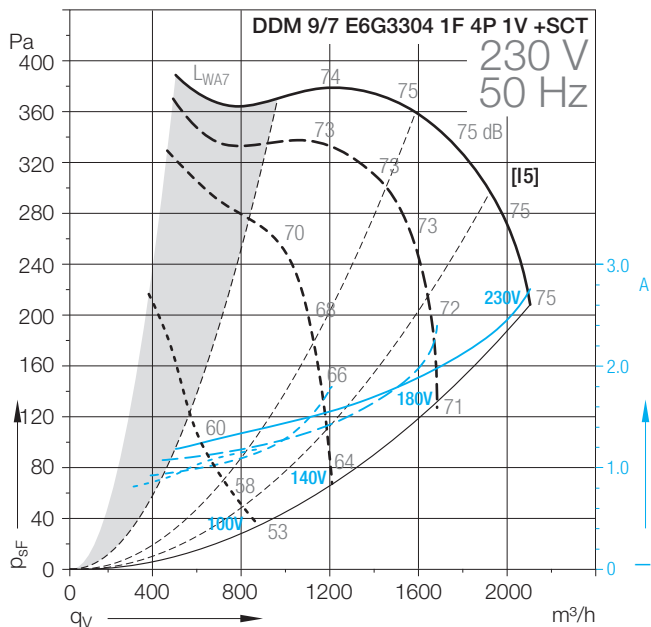
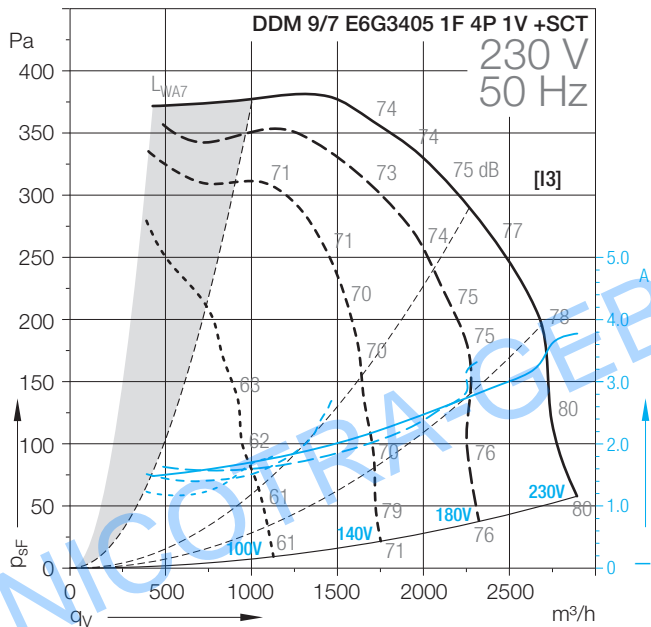
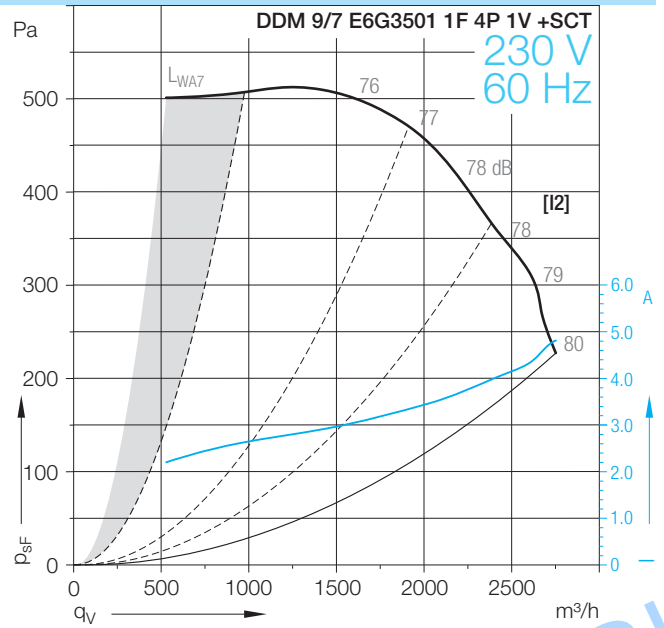
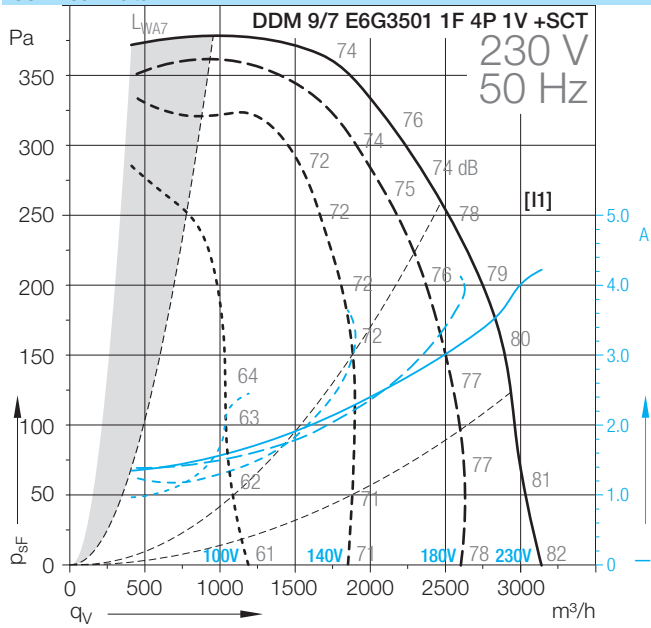

DDM-9/7

Technical Data

	Speed control	Curves	Nominal motor power W	Poles -	Phases	Connection	Mains frequency Hz	Max. power consumption W	Max. current consumption A	Speed 1/min
DDM 9/7										
E6G3501 1F 4P 1V +SCT	(2)	[1/1/2]	550	4	1~		50/60	1004	4.2	1290
E6G3405 1F 4P 1V +SCT	(2)	[3]	420	4	1~		50	908	3.6	1320
E6G3304 1F 4P 1V +SCT	(2)	[5]	300	4	1~		50	639	2.6	1260

Technical Data

	Operating Capacitor µF	Nominal capacitor voltage V	Motor protection class	Motor thermal class	Thermal protection	Media Temperature max. °C	Fan weight kg	Density of media kg/m³	Installation type (ISO 5801)	Article number
DDM 9/7										
E6G3501 1F 4P 1V +SCT	12.5	450	IP55	F	EXT	40	17	1.2	B	6M020M
E6G3405 1F 4P 1V +SCT	16	450	IP55	F	EXT	40	15	1.2	B	6M022A
E6G3304 1F 4P 1V +SCT	10	450	IP55	F	EXT	40	15	1.2	B	6M020N

(1) = Speed controllable via Transformer

(2) = Speed controllable via TRIAC or Transformer

(3) = Speed controllable via Inverter

* = No speed control available

[HI] High speed, [ME] Medium speed, [LO] Low speed

Attention! We suggest to do not use the fan in the grey marked area! The noise ratings given in the performance curves are sound power level L_{WA7} , see „Technical Description“.

Dimensions in mm, subject to change.

DDM 9/7 E6G3501 1F 4P 1V +SCT

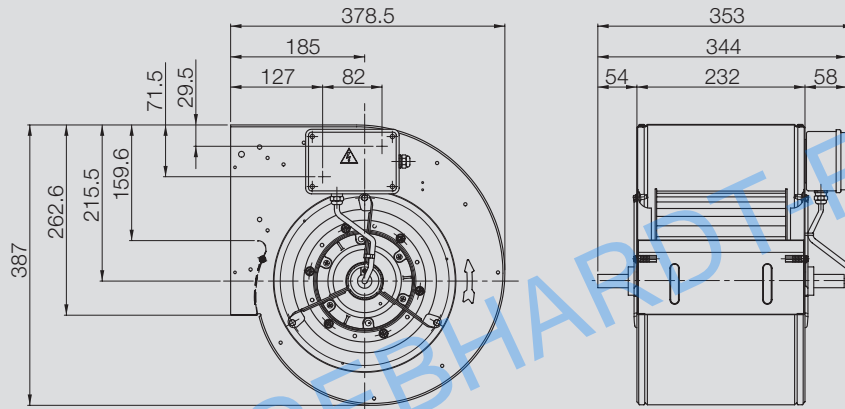

DDM 9/7 E6G3405 1F 4P 1V +SCT

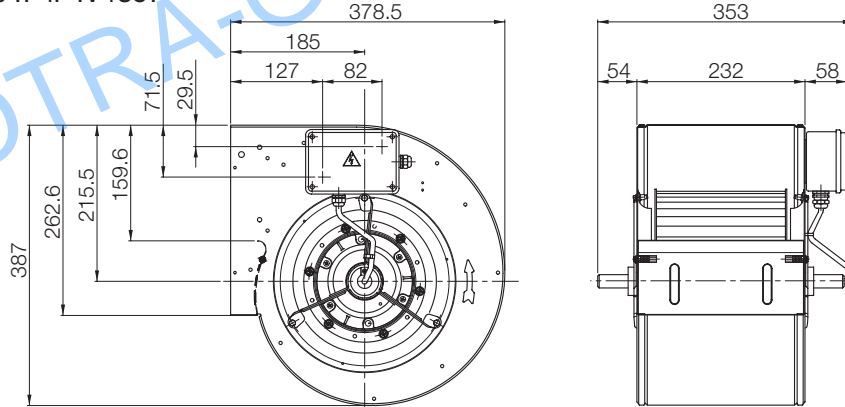

DDM 9/7 E6G3304 1F 4P 1V +SCT

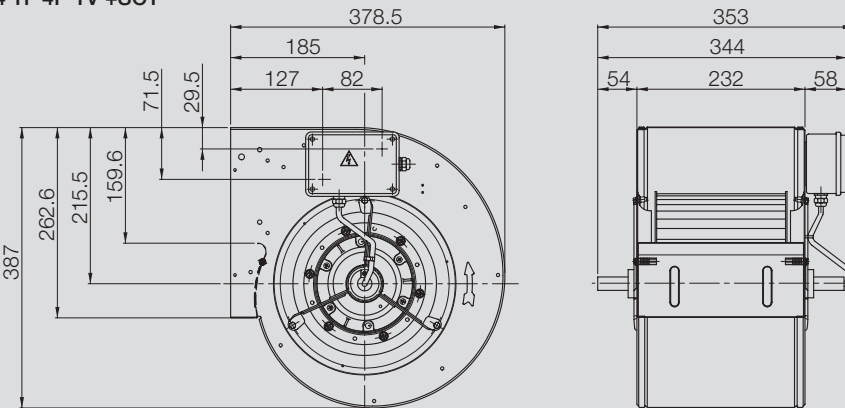

DDM-9/7

Technical Data

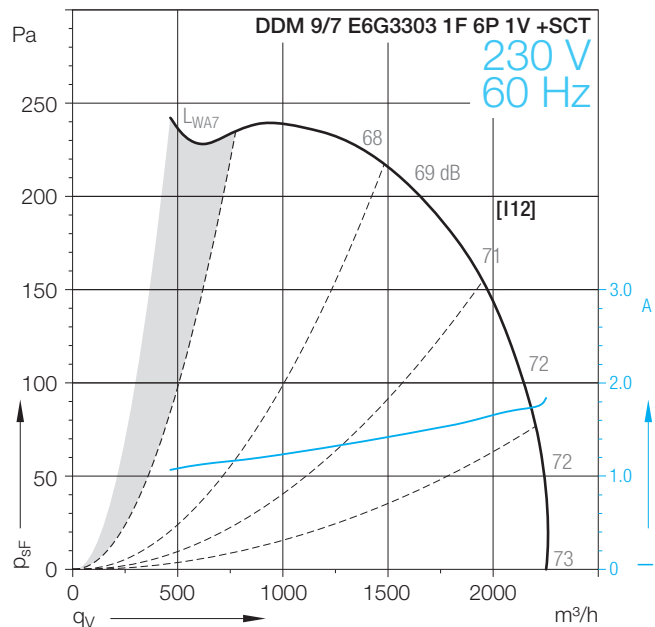
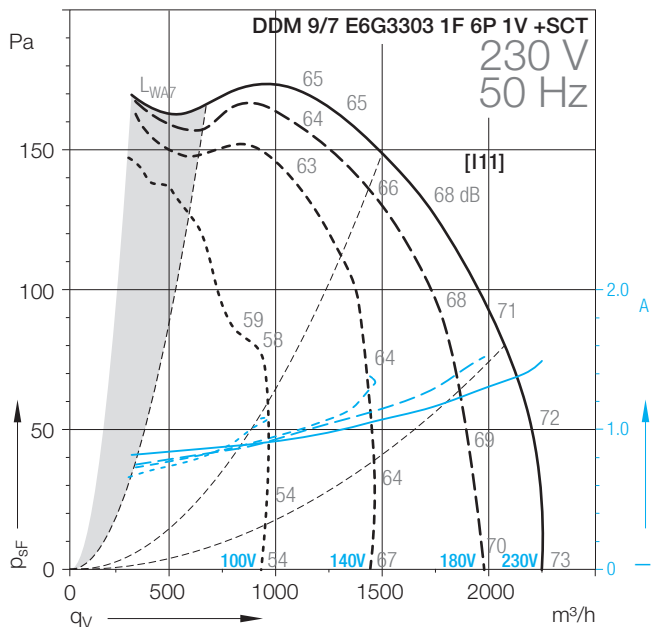
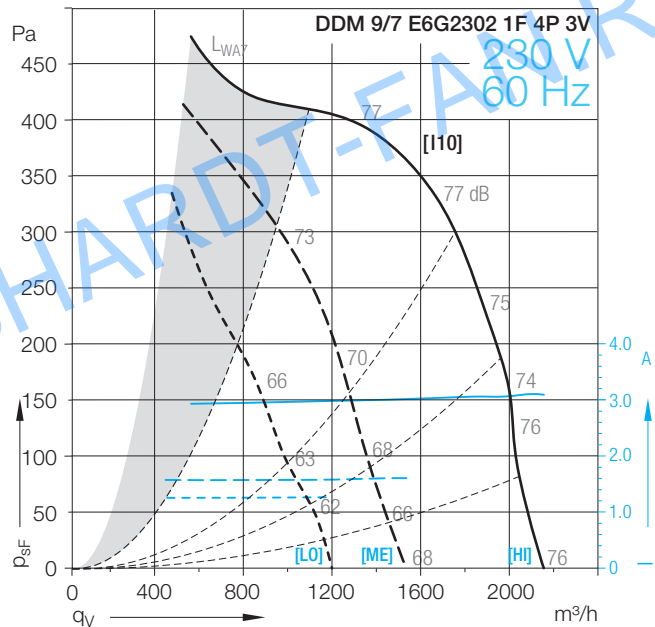
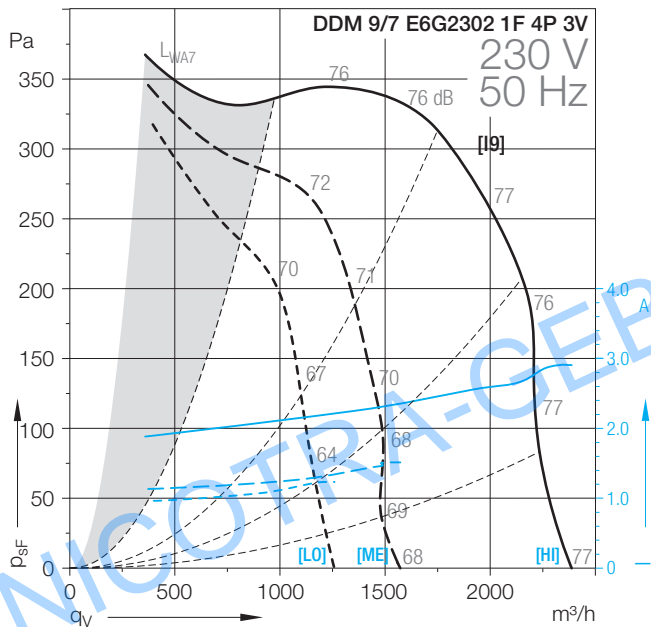
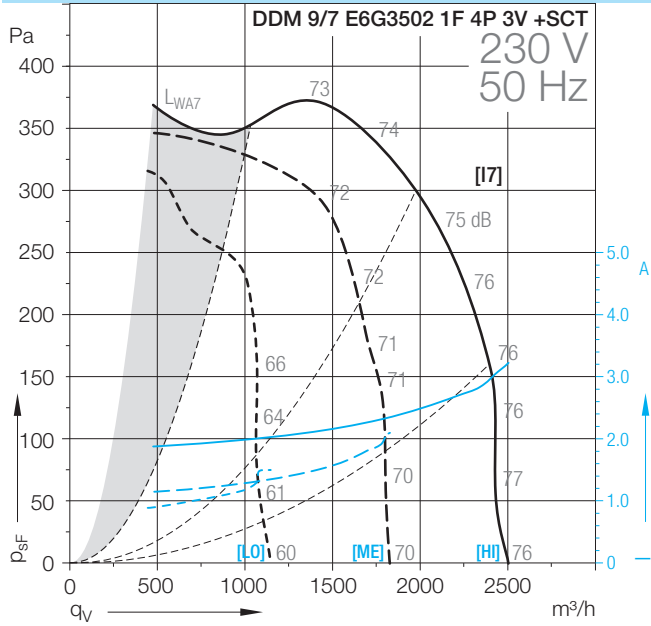

DDM-9/7

Technical Data										
	Speed control	Curves	Nominal motor power	Poles	Phases	Connection	Mains frequency	Max. power consumption	Max. current consumption	Speed
			W	-			Hz	W	A	1/min
DDM 9/7										
E6G3502 1F 4P 3V +SCT	*	[I7]	350	4	1~		50	742	3.1	1250
E6G2302 1F 4P 3V	*	[I9/I10]	250	4	1~		50/60	736	3	1260
E6G3303 1F 6P 1V +SCT	(2)	[I11/I12]	200	6	1~		50/60	345	1.5	840

Technical Data										
	Operating Capacitor	Nominal capacitor voltage	Motor protection class	Motor thermal class	Thermal protection	Media Temperature max.	Fan weight	Density of media	Installation type (ISO 5801)	Article number
	µF	V				°C	kg	kg/m³		
DDM 9/7										
E6G3502 1F 4P 3V +SCT	12.5	450	IP55	F	EXT	40	17	1.2	B	6M02U9
E6G2302 1F 4P 3V	12.5	500	IP10	F	EXT	40	13	1.2	B	6M02ZN
E6G3303 1F 6P 1V +SCT	8	450	IP55	F	EXT	70	13	1.2	B	6M02H8

- (1) = Speed controllable via Transformer
- (2) = Speed controllable via TRIAC or Transformer
- (3) = Speed controllable via Inverter
- * = No speed control available

[HI] High speed, [ME] Medium speed, [LO] Low speed
Attention! We suggest to do not use the fan in the grey marked area! The noise ratings given in the performance curves are sound power level L_{WA7} , see „Technical Description“.

Dimensions in mm, subject to change.

DDM 9/7 E6G3502 1F 4P 3V +SCT

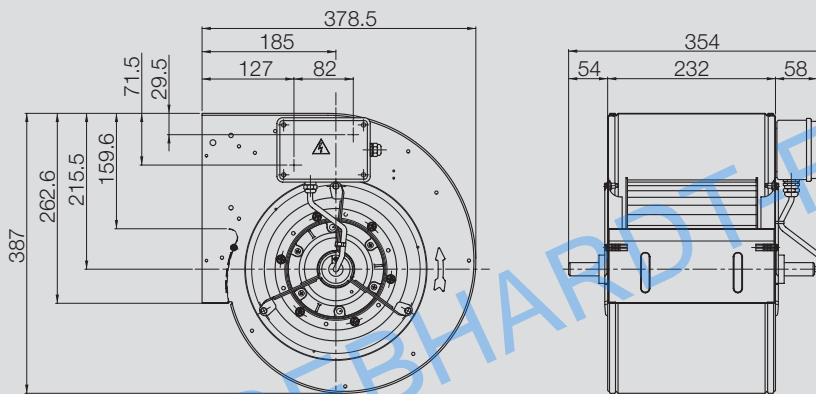

DDM 9/7 E6G2302 1F 4P 3V +SCT

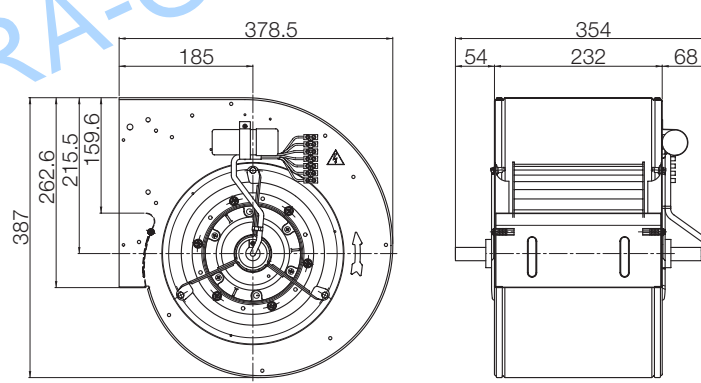

DDM 9/7 E6G3303 1F 6P 1V +SCT

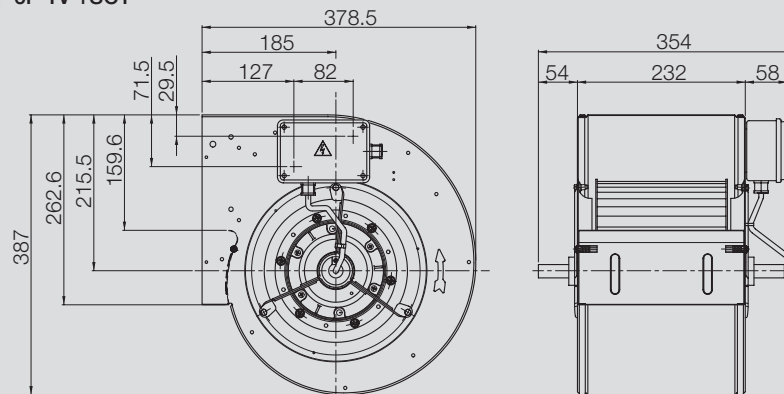

DDM-9/7

Technical Data

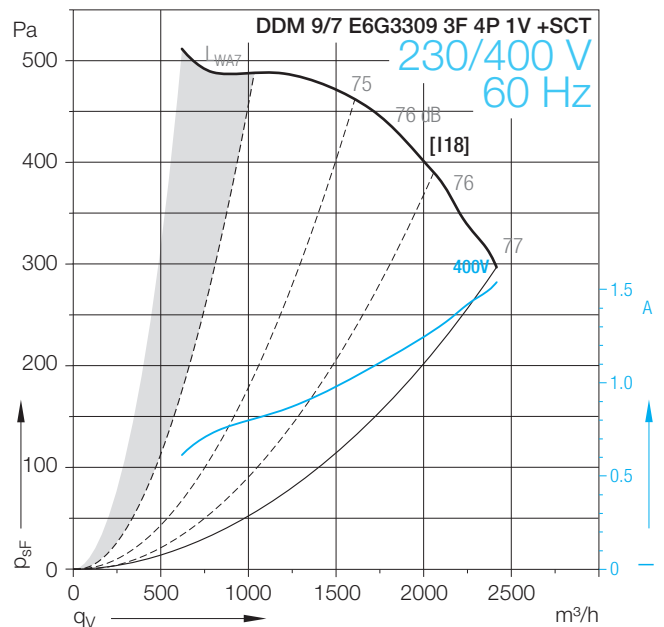
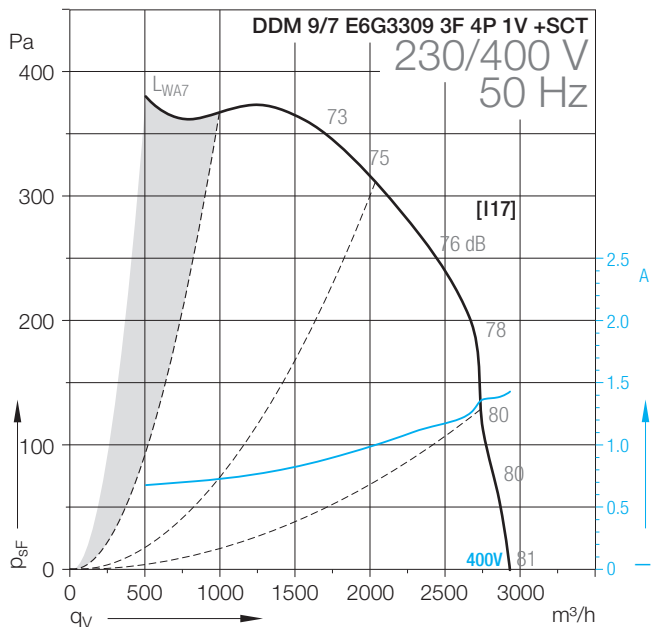
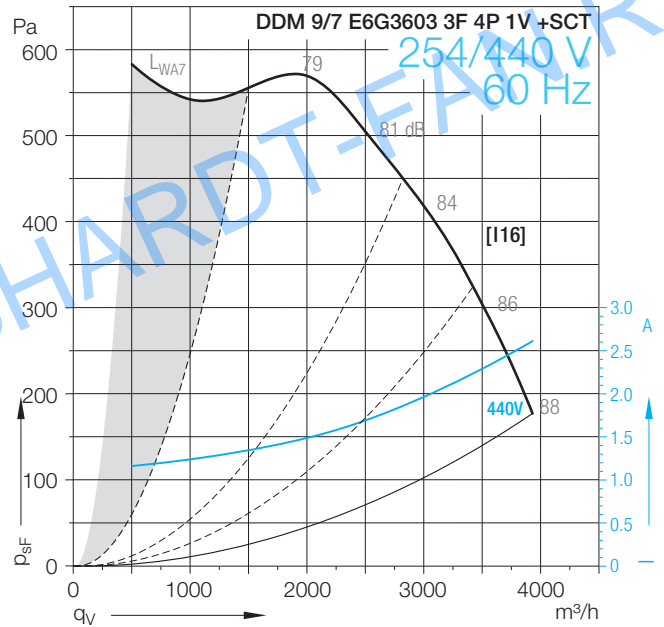
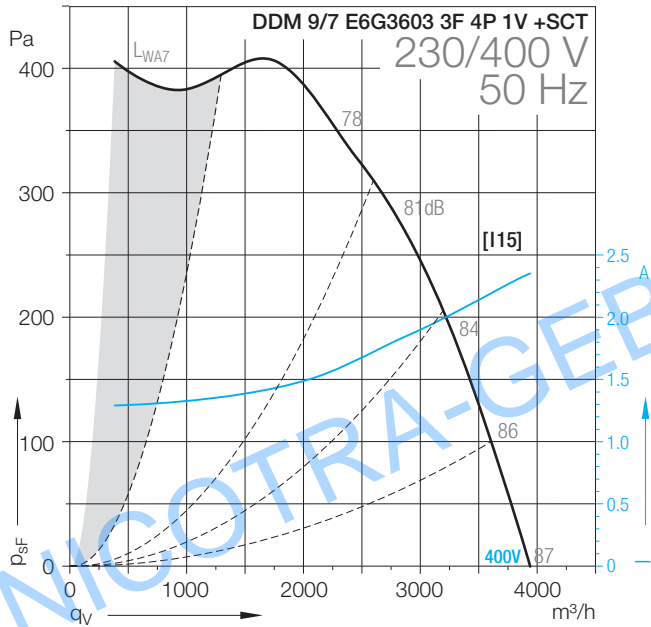
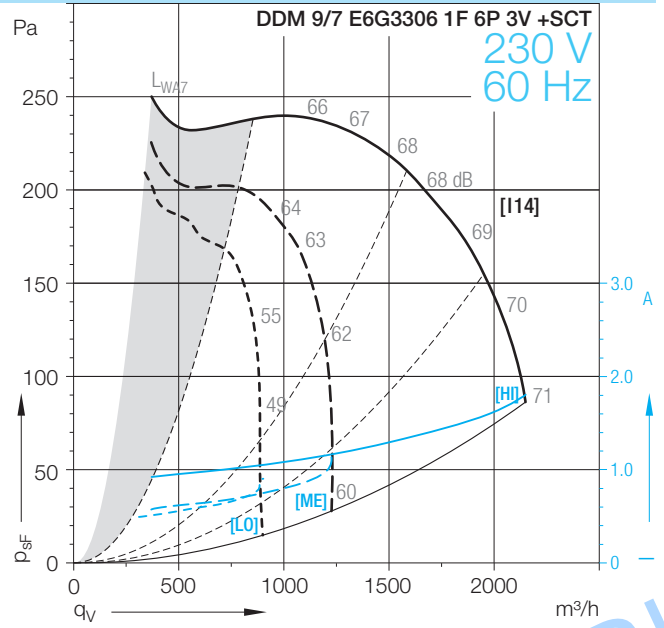
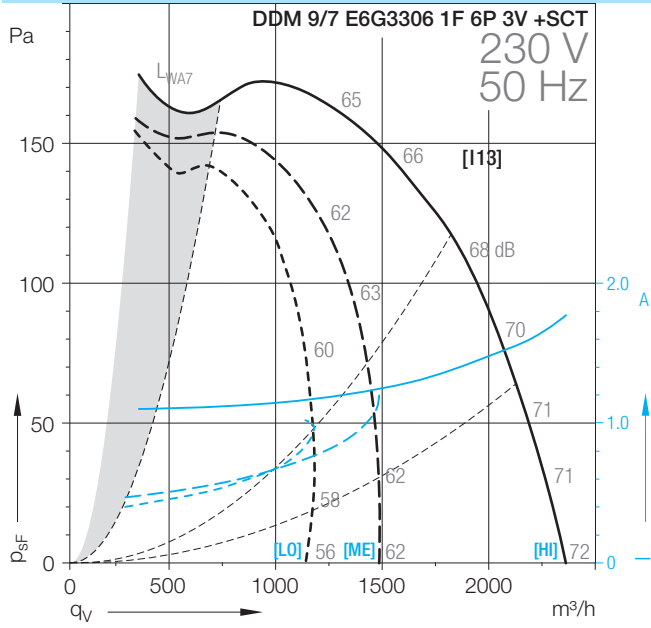

DDM-9/7

Technical Data										
	Speed control	Curves	Nominal motor power	Poles	Phases	Connection	Mains frequency	Max. power consumption	Max. current consumption	Speed
DDM 9/7			W	-			Hz	W	A	1/min
E6G3306 1F 6P 3V +SCT	*	[13/114]	200	6	1~		50/60	415	1.7	830
E6G3603 3F 4P 1V +SCT	*	[15/116]	550	4	3~	Δ/Y	50/60	1355	2.3	1410
E6G3309 3F 4P 1V +SCT	*	[17/118]	300	4	3~	Δ/Y	50/60	843	1.4	1360

Technical Data										
	Operating Capacitor	Nominal capacitor voltage	Motor protection class	Motor thermal class	Thermal protection	Media Temperature max.	Fan weight	Density of media	Installation type (ISO 5801)	Article number
DDM 9/7	μF	V				°C	kg	kg/m ³		
E6G3306 1F 6P 3V +SCT	8	450	IP44	F	EXT	40	15	1.2	B	6M02WP
E6G3603 3F 4P 1V +SCT			IP55	F	EXT	40	12	1.2	B	6102WT
E6G3309 3F 4P 1V +SCT			IP55	F	EXT	40	10	1.2	B	6M02WR

- (1) = Speed controllable via Transformer
- (2) = Speed controllable via TRIAC or Transformer
- (3) = Speed controllable via Inverter
- * = No speed control available

[HI] High speed, [ME] Medium speed, [LO] Low speed

Attention! We suggest to do not use the fan in the grey marked area! The noise ratings given in the performance curves are sound power level L_{WA7} , see „Technical Description“.

Dimensions in mm, subject to change.

DDM 9/7 E6G3306 1F 6P 3V +SCT

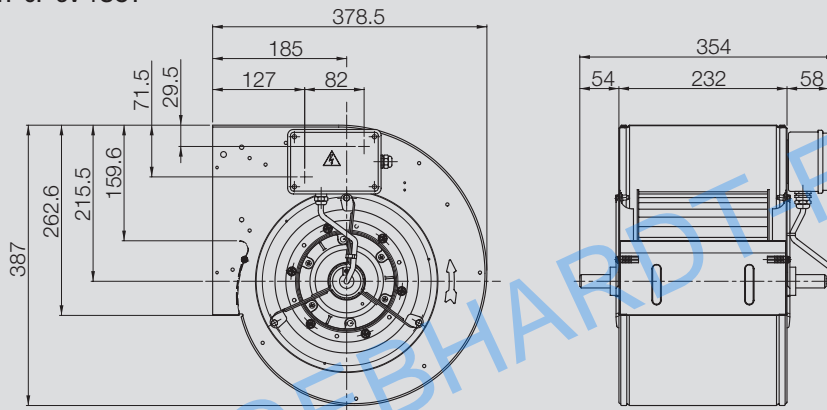

DDM 9/7 E6G3603 3F 4P 1V +SCT

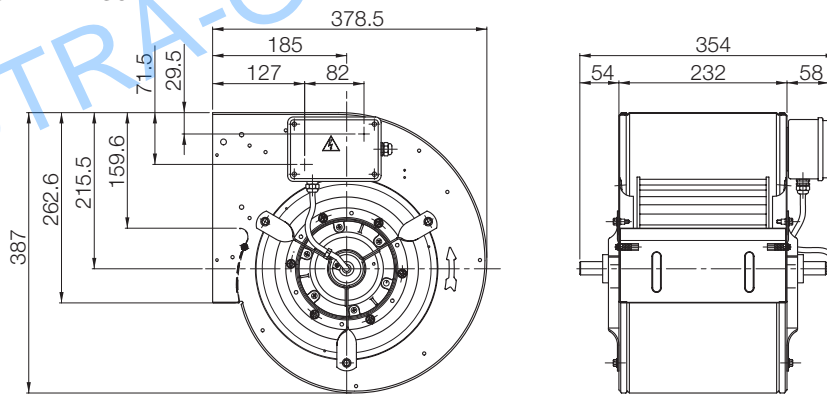

DDM 9/7 E6G3309 3F 4P 1V +SCT

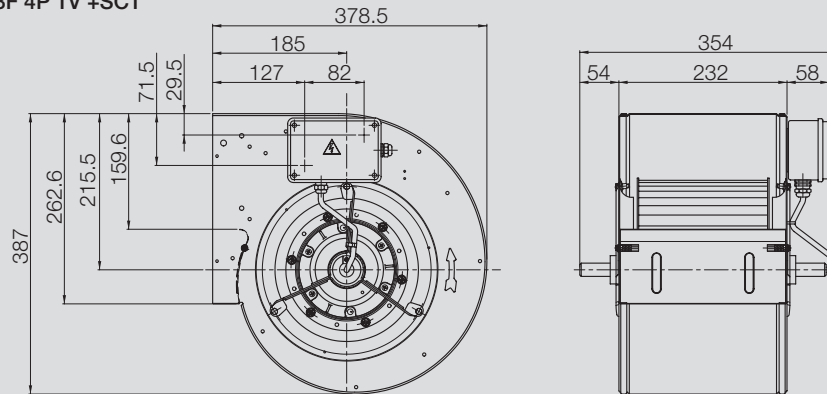

DDM-9/7 TIGHT

Technical Data

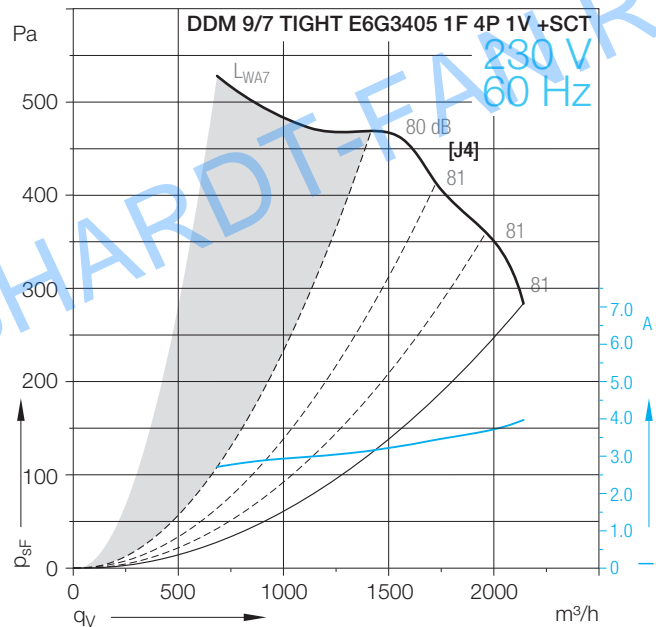
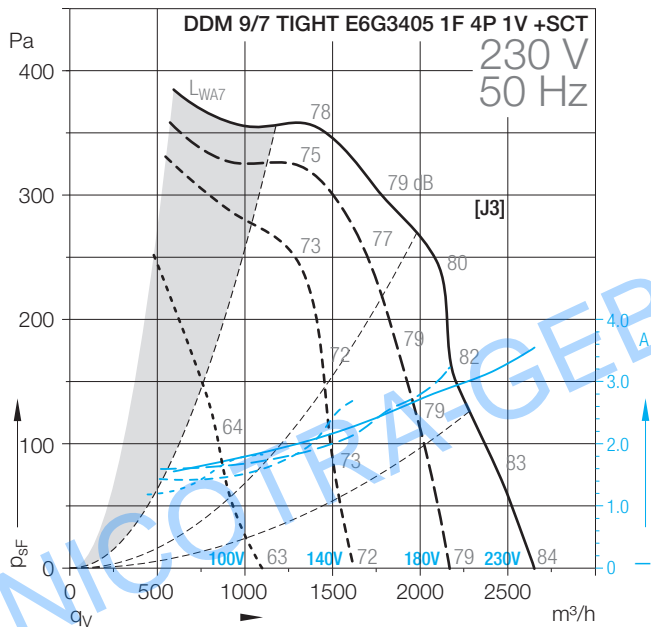
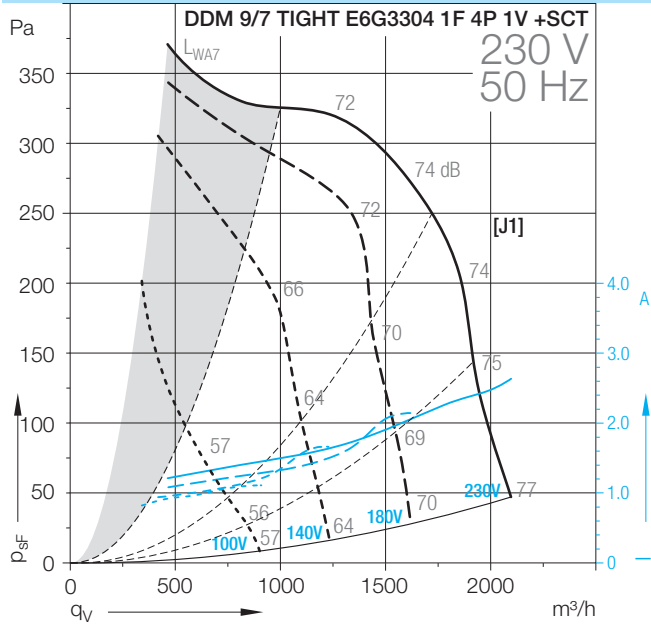

DDM-9/7 TIGHT

Technical Data										
	Speed control	Curves	Nominal motor power	Poles	Phases	Connection	Mains frequency	Max. power consumption	Max. current consumption	Speed
DDM 9/7 TIGHT			W	-			Hz	W	A	1/min
E6G3304 1F 4P 1V +SCT	(2)	[J1]	300	4	1~		50	627	2.6	1260
E6G3405 1F 4P 1V +SCT	(2)	[J3/J4]	420	4	1~		50/60	821	3.6	1320

Technical Data										
DDM 9/7 TIGHT	Operating Capacitor	Nominal capacitor voltage	Motor protection class	Motor thermal class	Thermal protection	Media Temperature max.	Fan weight	Density of media	Installation type (ISO 5801)	Article number
	µF	V				°C	kg	kg/m³		
E6G3304 1F 4P 1V +SCT	10	450	IP55	F	EXT	40	17	1.2	B	6M02WX
E6G3405 1F 4P 1V +SCT	16	450	IP55	F	EXT	40	16	1.2	B	6M02WY

(1) = Speed controllable via Transformer

(2) = Speed controllable via TRIAC or Transformer

(3) = Speed controllable via Inverter

* = No speed control available

[HI] High speed, [ME] Medium speed, [LO] Low speed

Attention! We suggest to do not use the fan in the grey marked area! The noise ratings given in the performance curves are sound power level L_{WA7} , see „Technical Description“.

Dimensions in mm, subject to change.

DDM 9/7 TIGHT E6G3304 1F 4P 1V +SCT

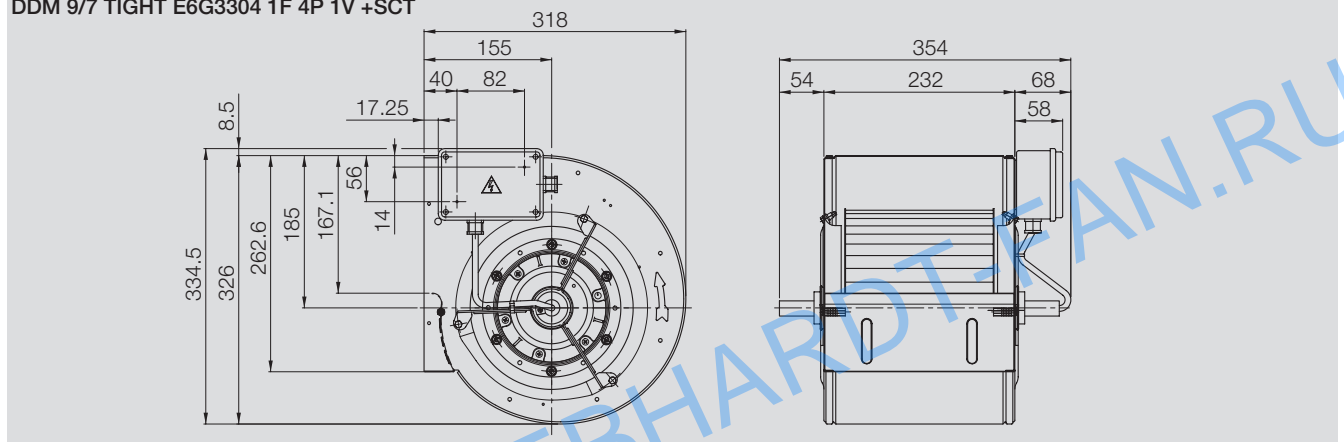

DDM 9/7 TIGHT E6G3405 1F 4P 1V +SCT

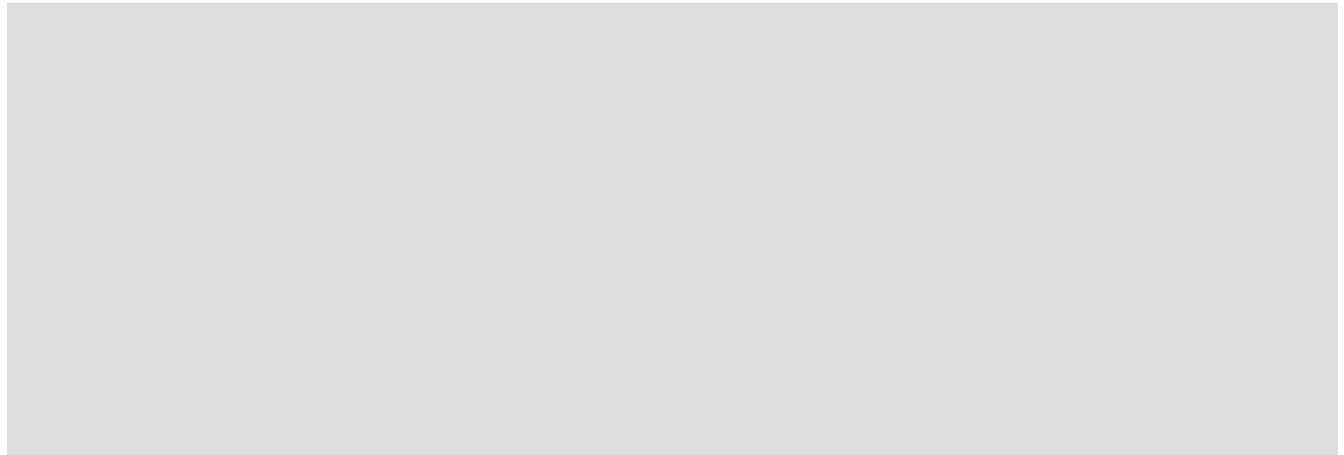
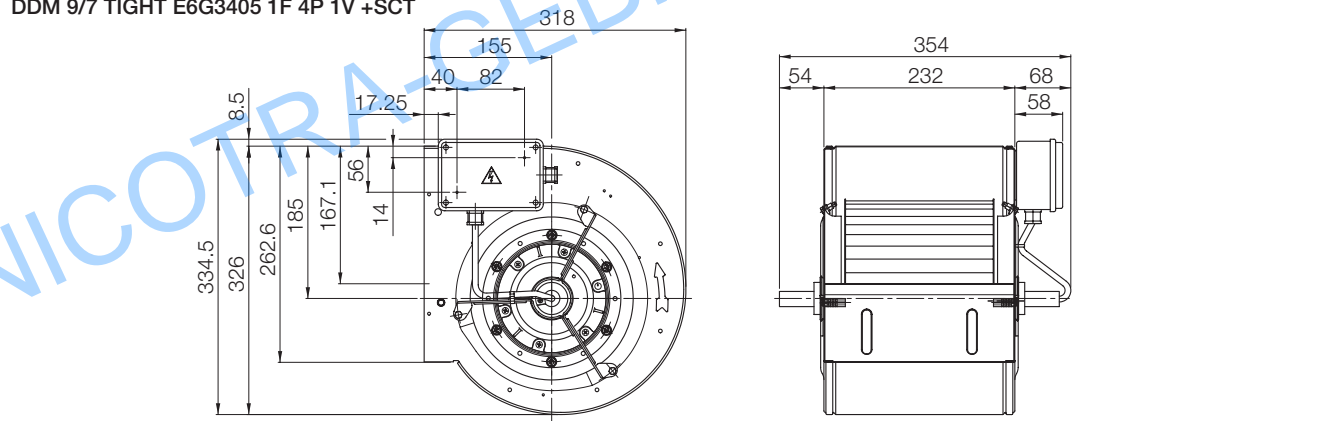

DDM-9/9

Technical Data

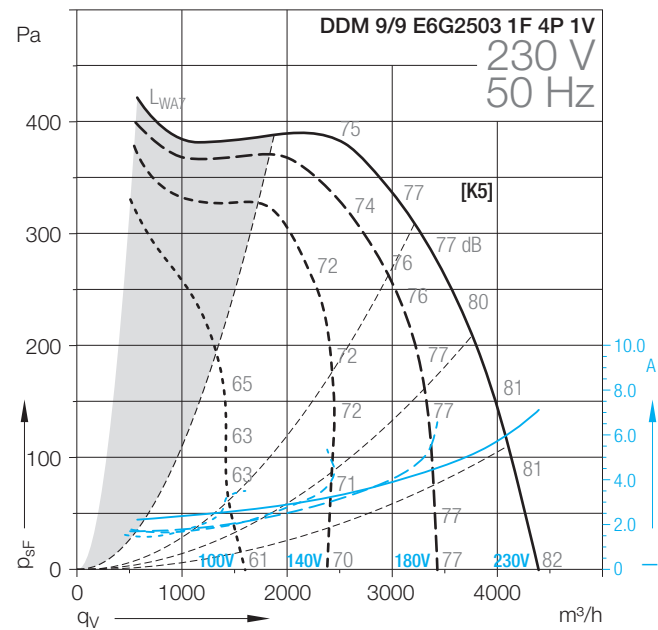
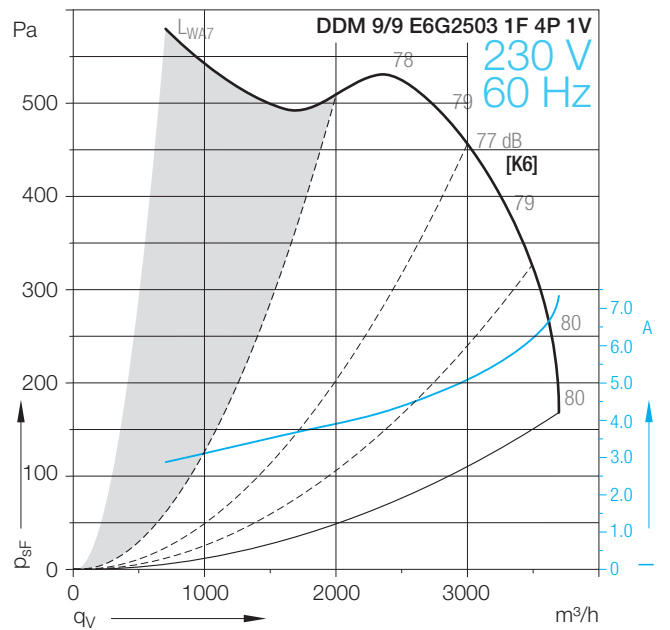
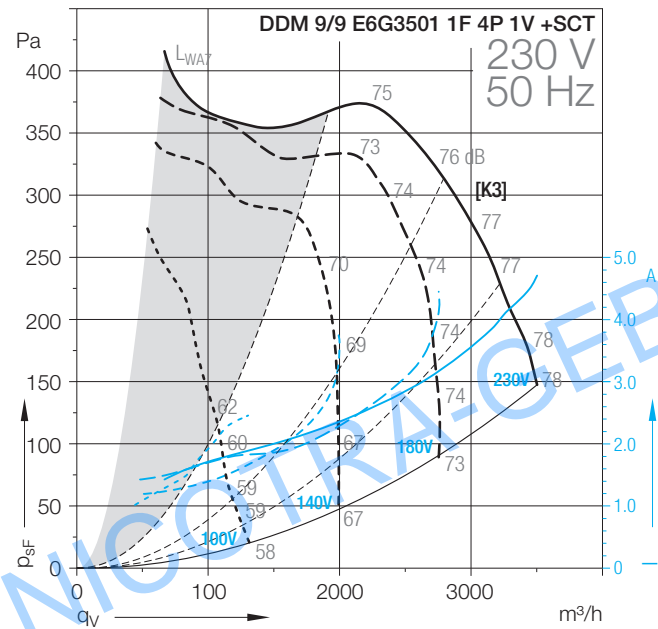
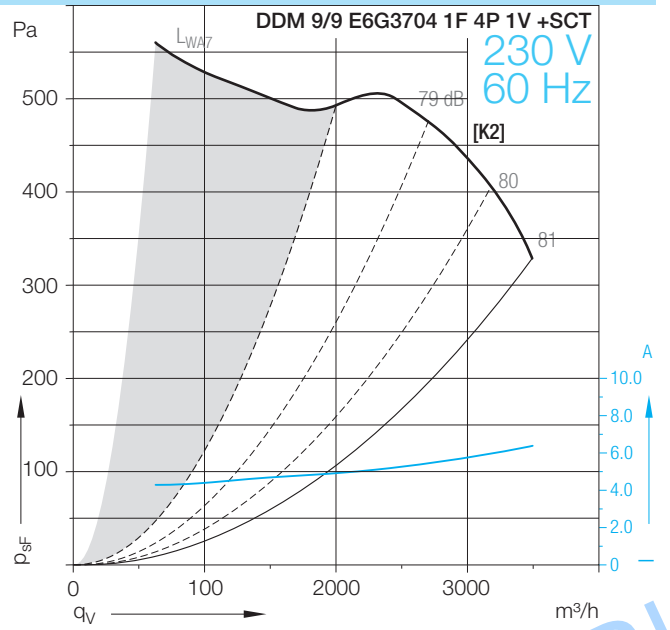
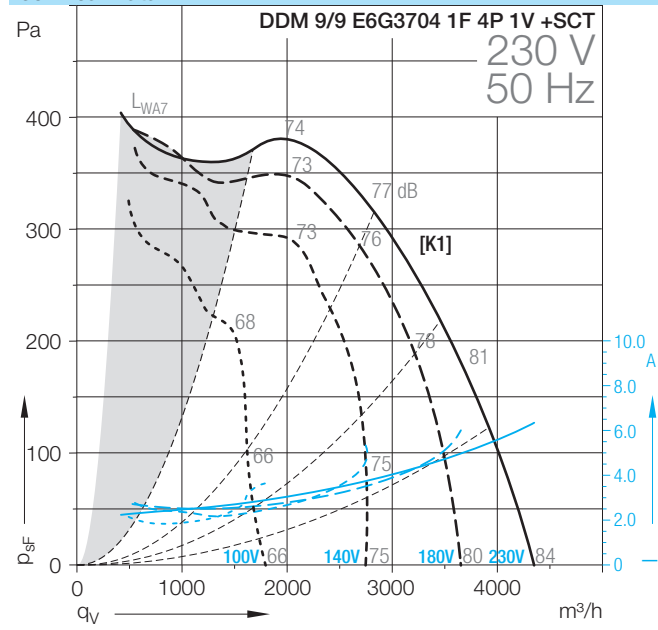

DDM-9/9

Technical Data										
	Speed control	Curves	Nominal motor power	Poles	Phases	Connection	Mains frequency	Max. power consumption	Max. current consumption	Speed
DDM 9/9			W	-			Hz	W	A	1/min
E6G3704 1F 4P 1V +SCT	(2)	[K1/K2]	600	4	1~		50/60	1480	6.3	1380
E6G3501 1F 4P 1V +SCT	(2)	[K3]	550	4	1~		50	1107	4.6	1290
E6G2503 1F 4P 1V	(2)	[K5/K6]	550	4	1~		50/60	1611	6.8	1400

Technical Data										
	Operating Capacitor	Nominal capacitor voltage	Motor protection class	Motor thermal class	Thermal protection	Media Temperature max.	Fan weight	Density of media	Installation type (ISO 5801)	Article number
DDM 9/9	µF	V				°C	kg	kg/m³		
E6G3704 1F 4P 1V +SCT	25	450	IP55	F	EXT	40	17	1.2	B	6M020Z
E6G3501 1F 4P 1V +SCT	12.5	450	IP55	F	EXT	40	17	1.2	B	6M02H5
E6G2503 1F 4P 1V	20	450	IP10	F	EXT	40	17	1.2	B	6M02R8

- (1) = Speed controllable via Transformer
- (2) = Speed controllable via TRIAC or Transformer
- (3) = Speed controllable via Inverter
- * = No speed control available

[H] High speed, [ME] Medium speed, [LO] Low speed
Attention! We suggest to do not use the fan in the grey marked area! The noise ratings given in the performance curves are sound power level L_{WA7} , see „Technical Description“.

Dimensions in mm, subject to change.

DDM 9/9 E6G3704 1F 4P 1V +SCT

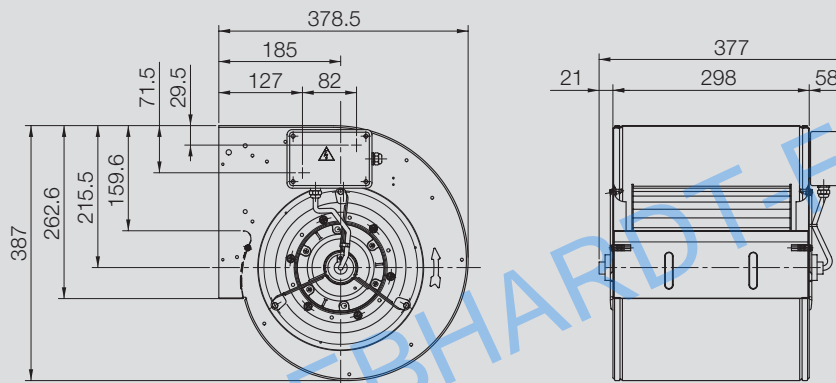

DDM 9/9 E6G3501 1F 4P 1V +SCT

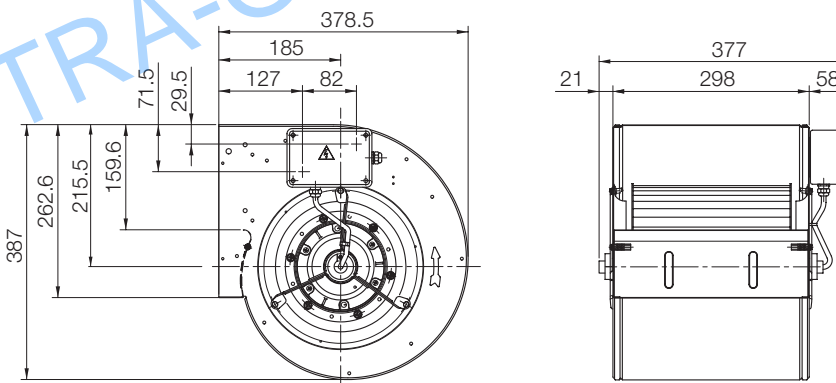

DDM 9/9 E6G2503 1F 4P 1V +SCT

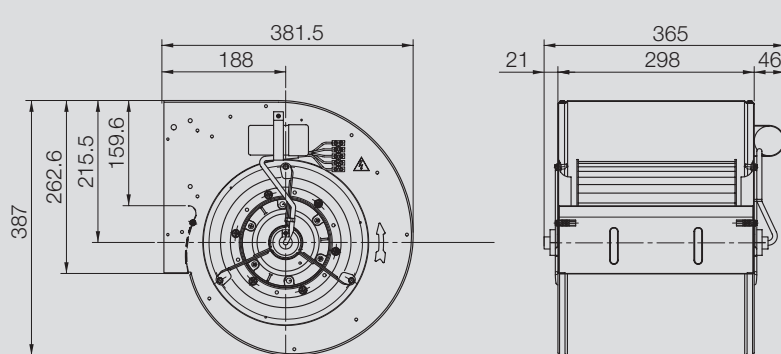

DDM-9/9

Technical Data

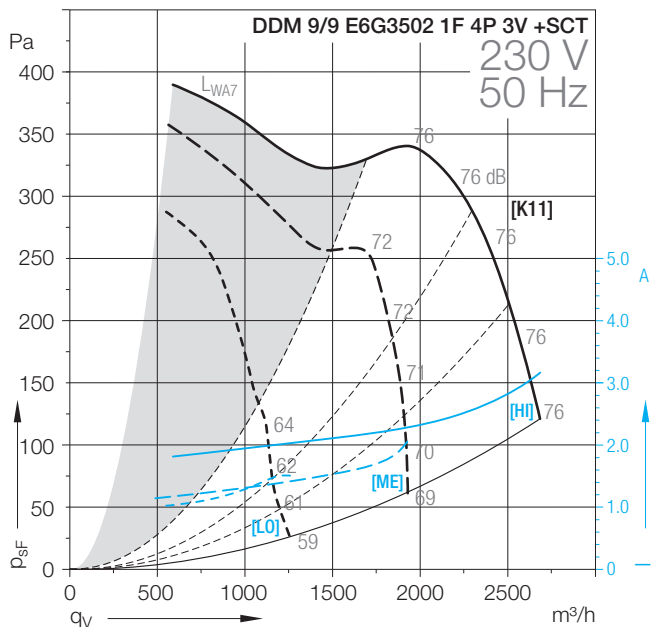
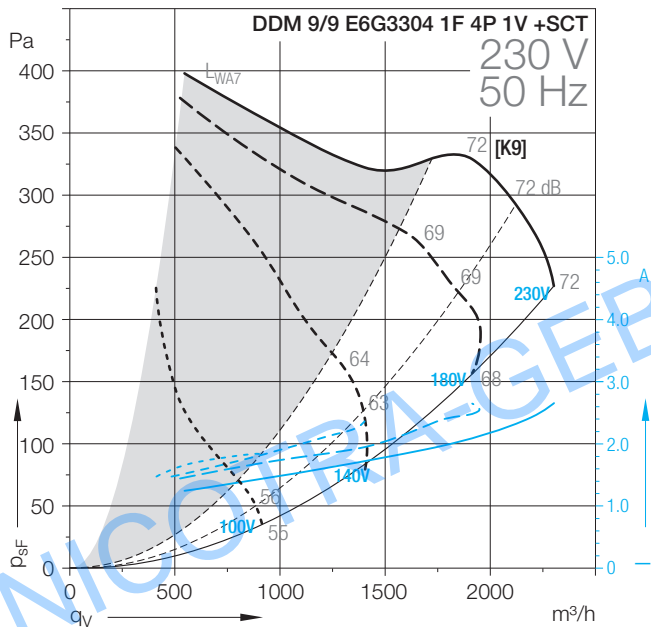
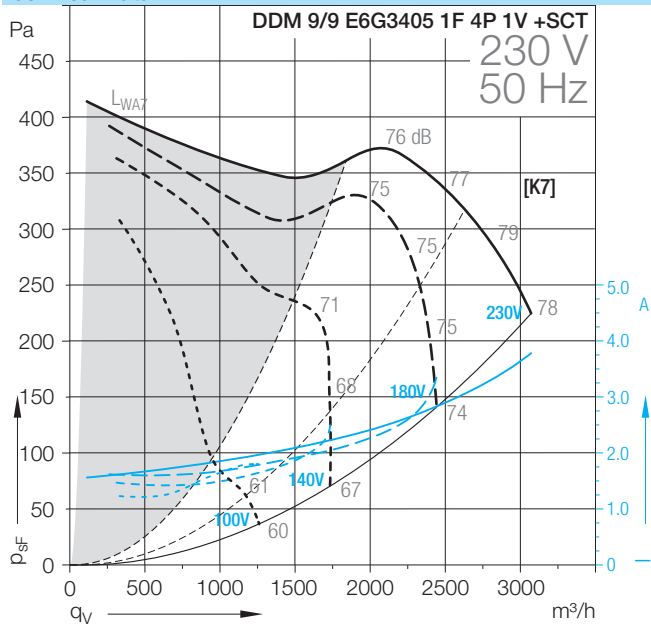

DDM-9/9

Technical Data										
	Speed control	Curves	Nominal motor power	Poles	Phases	Connection	Mains frequency	Max. power consumption	Max. current consumption	Speed
DDM 9/9			W	-			Hz	W	A	1/min
E6G3405 1F 4P 1V +SCT	(2)	[K7]	420	4	1~		50	920	3.6	1320
E6G3304 1F 4P 1V +SCT	(2)	[K9]	300	4	1~		50	354	2.5	1260
E6G3502 1F 4P 3V +SCT	*	[K11]	350	4	1~		50	734	3	1250

Technical Data										
	Operating Capacitor	Nominal capacitor voltage	Motor protection class	Motor thermal class	Thermal protection	Media Temperature max.	Fan weight	Density of media	Installation type (ISO 5801)	Article number
DDM 9/9	µF	V				°C	kg	kg/m³		
E6G3405 1F 4P 1V +SCT	16	450	IP55	F	EXT	40	17	1.2	B	6M02XN
E6G3304 1F 4P 1V +SCT	10	450	IP55	F	EXT	40	16	1.2	B	6M02K1
E6G3502 1F 4P 3V +SCT	12.5	450	IP55	F	EXT	40	16	1.2	B	6M02W0

- (1) = Speed controllable via Transformer
- (2) = Speed controllable via TRIAC or Transformer
- (3) = Speed controllable via Inverter
- * = No speed control available

[H] High speed, [ME] Medium speed, [LO] Low speed
Attention! We suggest to do not use the fan in the grey marked area! The noise ratings given in the performance curves are sound power level L_{WA7} , see „Technical Description“.

Dimensions in mm, subject to change.

DDM 9/9 E6G3405 1F 4P 1V +SCT

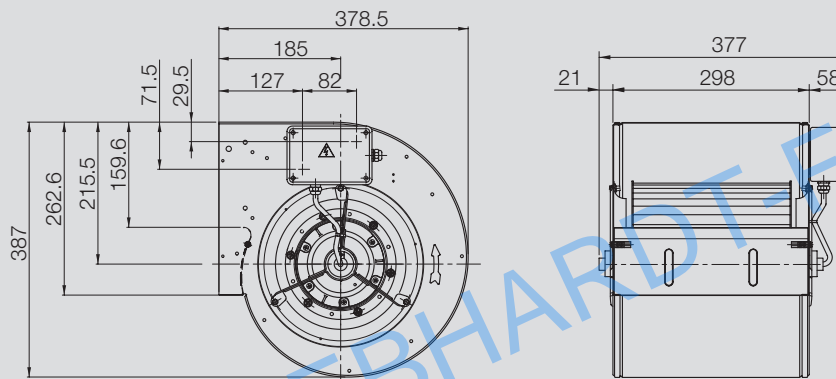

DDM 9/9 E6G3304 1F 4P 1V +SCT

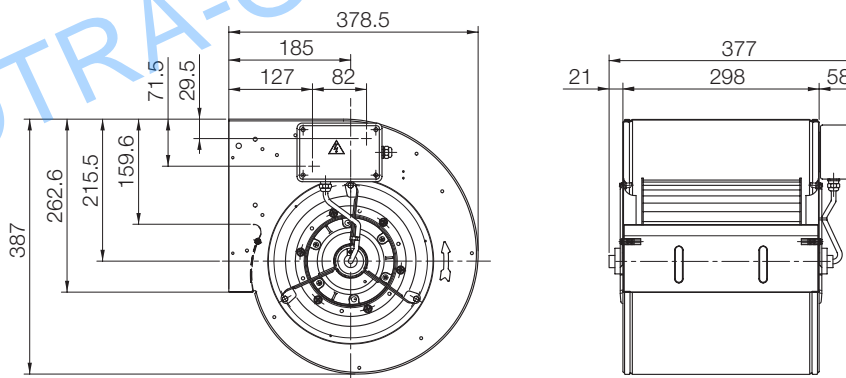

DDM 9/9 E6G3502 1F 4P 3V +SCT

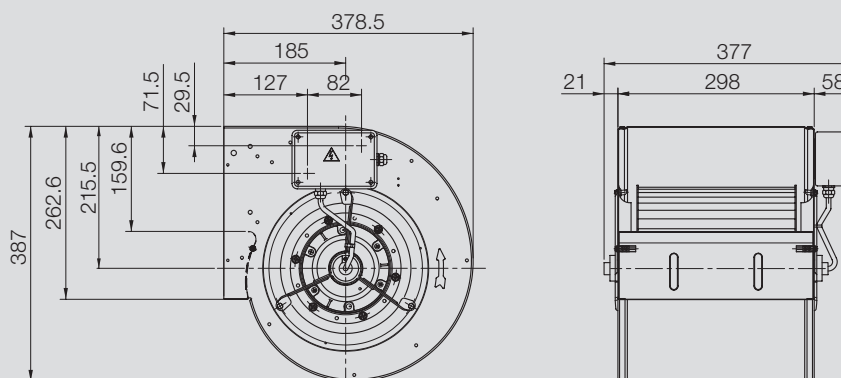

DDM-9/9

Technical Data

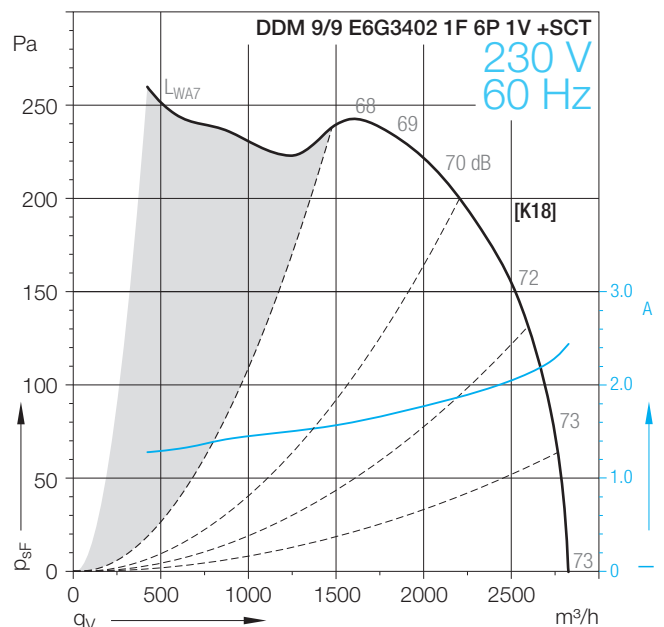
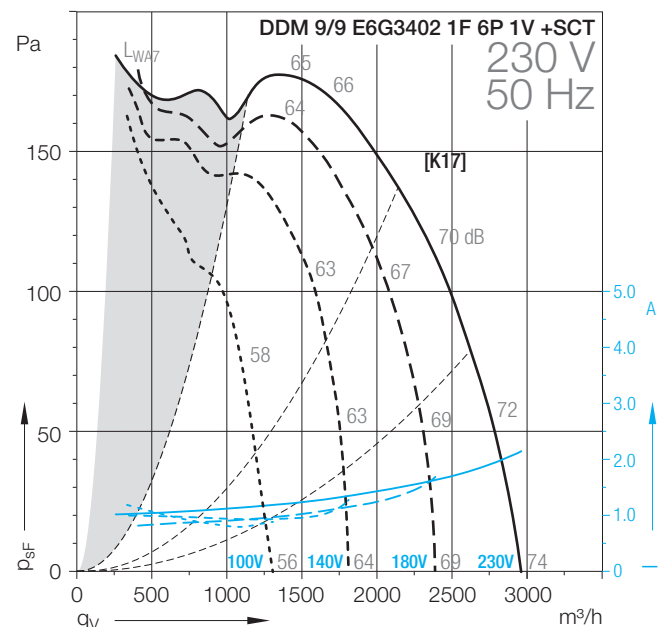
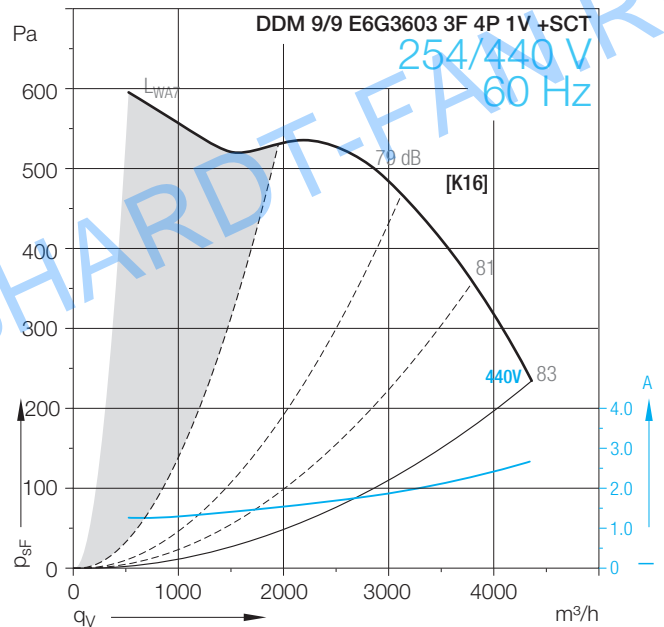
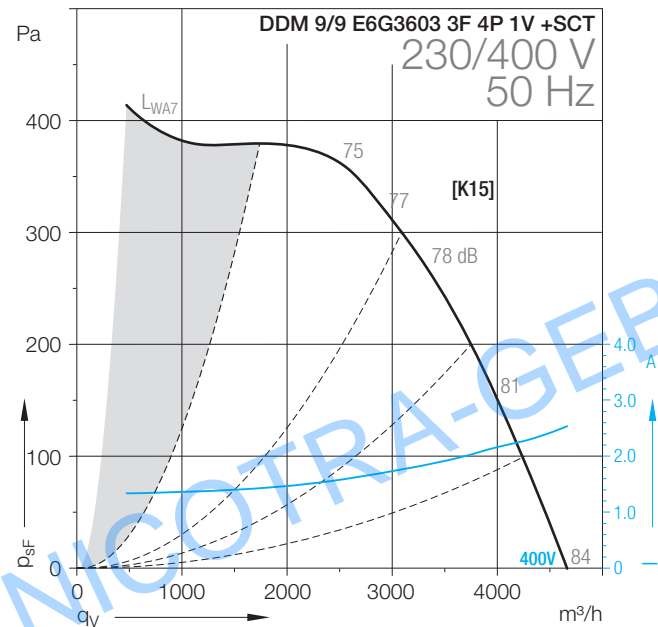
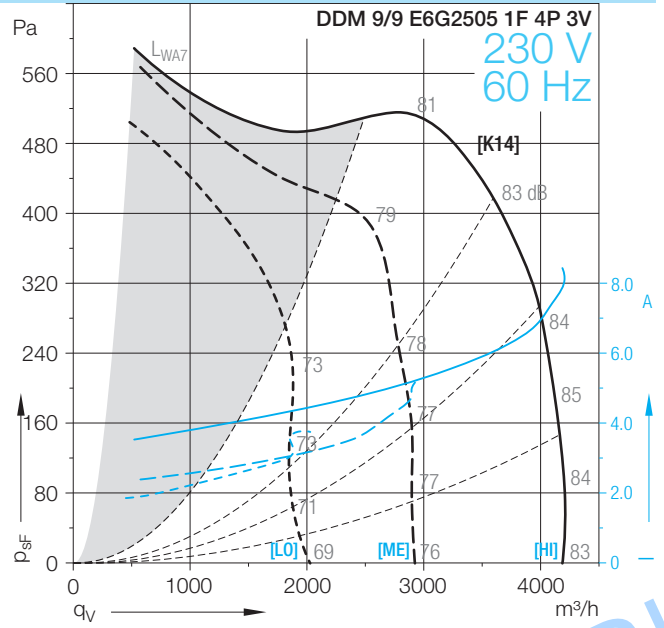
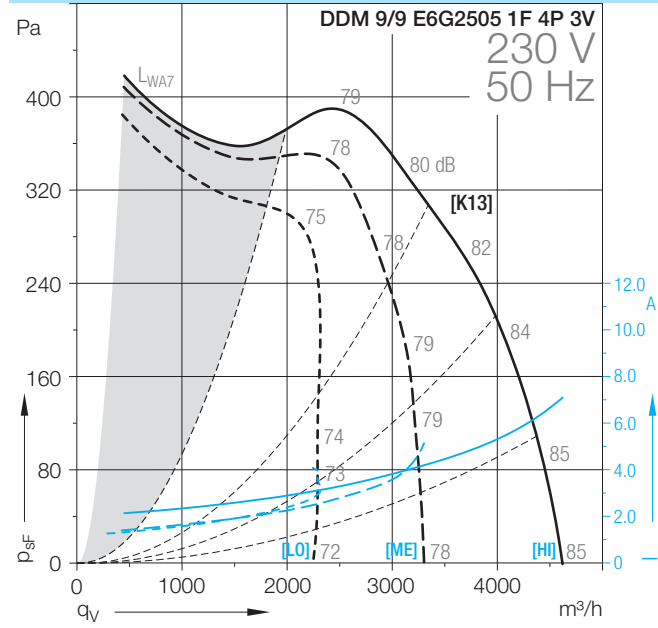

DDM-9/9

Technical Data										
	Speed control	Curves	Nominal motor power	Poles	Phases	Connection	Mains frequency	Max. power consumption	Max. current consumption	Speed
DDM 9/9			W	-			Hz	W	A	1/min
E6G2505 1F 4P 3V	*	[K13/K14]	550	4	1~		50/60	1644	7.1	1400
E6G3603 3F 4P 1V +SCT	*	[K15/K16]	550	4	3~	Δ/Y	50/60	1482	2.5	1410
E6G3402 1F 6P 1V +SCT	(2)	[K17/K18]	250	6	1~		50/60	486	2.2	800

Technical Data										
	Operating Capacitor	Nominal capacitor voltage	Motor protection class	Motor thermal class	Thermal protection	Media Temperature max.	Fan weight	Density of media	Installation type (ISO 5801)	Article number
DDM 9/9	μF	V				°C	kg	kg/m³		
E6G2505 1F 4P 3V	25	450	IP10	F	EXT	40	18	1.2	B	6M02007
E6G3603 3F 4P 1V +SCT			IP55	F	EXT	40	16	1.2	B	6M028A
E6G3402 1F 6P 1V +SCT	12.5	450	IP55	F	EXT	70	16	1.2	B	6M02NM

(1) = Speed controllable via Transformer

(2) = Speed controllable via TRIAC or Transformer

(3) = Speed controllable via Inverter

* = No speed control available

[HI] High speed, [ME] Medium speed, [LO] Low speed

Attention! We suggest to do not use the fan in the grey marked area! The noise ratings given in the performance curves are sound power level L_{WA7} , see „Technical Description“.

Dimensions in mm, subject to change.

DDM 9/9 E6G2505 1F 4P 3V

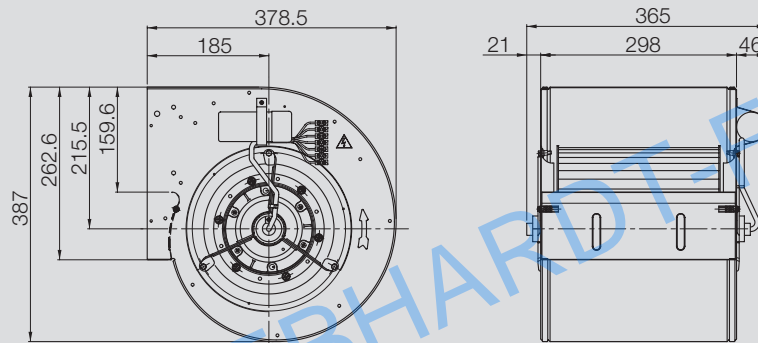

DDM 9/9 E6G3603 3F 4P 1V +SCT

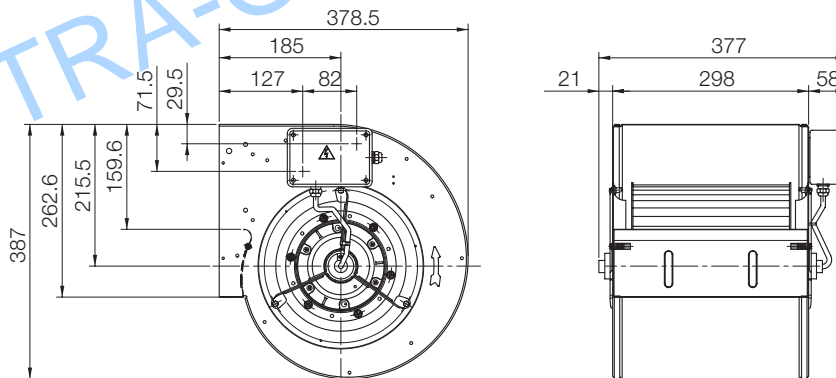

DDM 9/9 E6G3402 1F 6P 1V +SCT

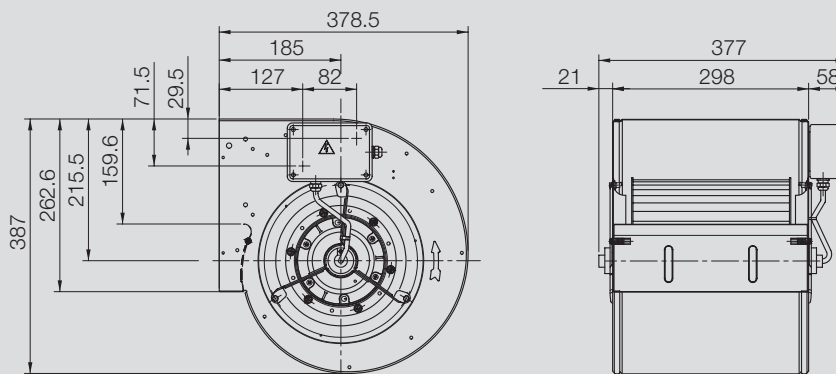

DDM-9/9

Technical Data

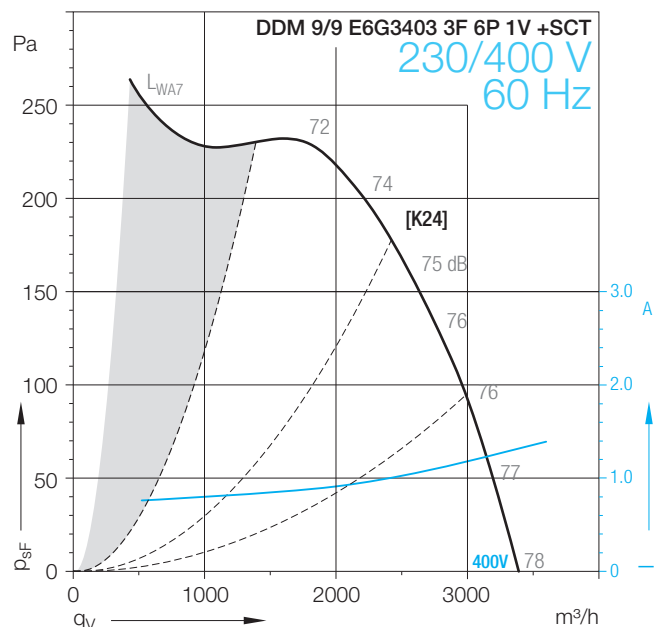
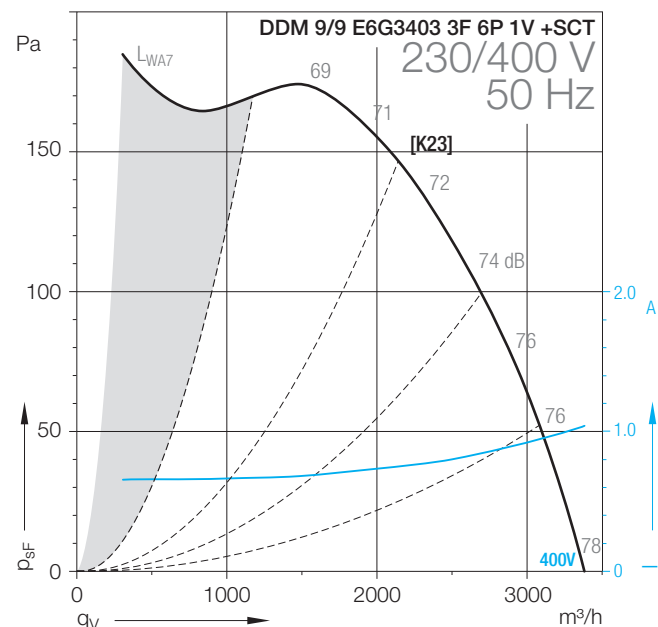
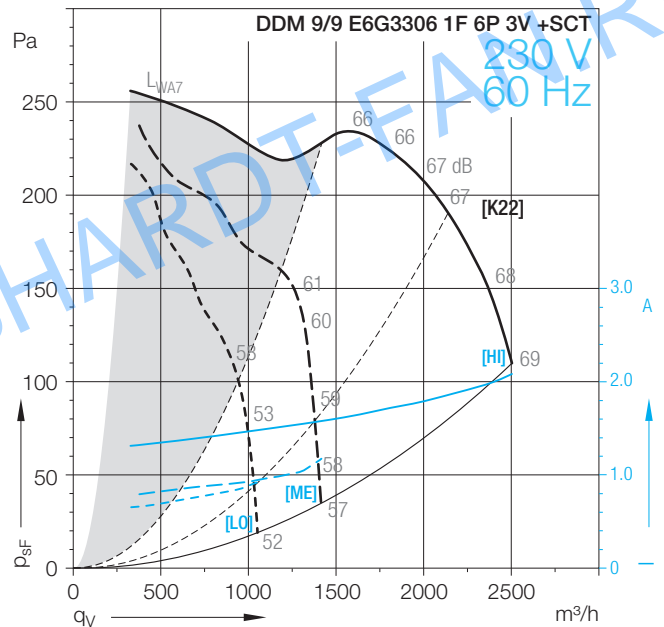
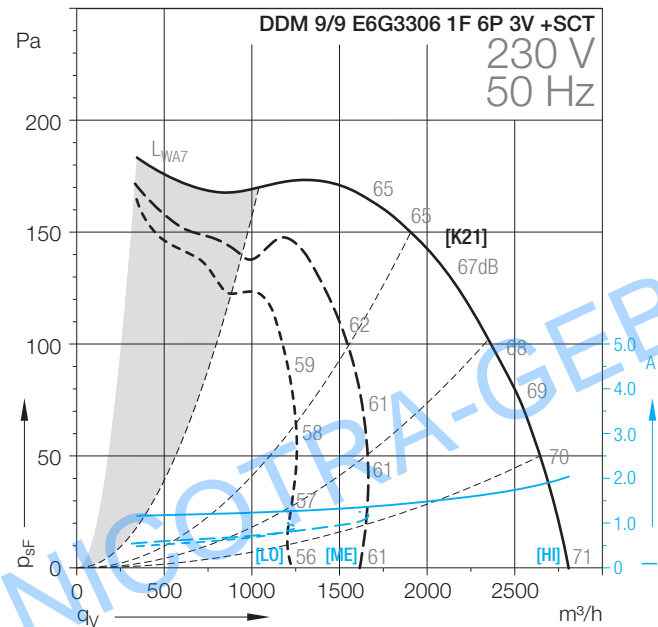
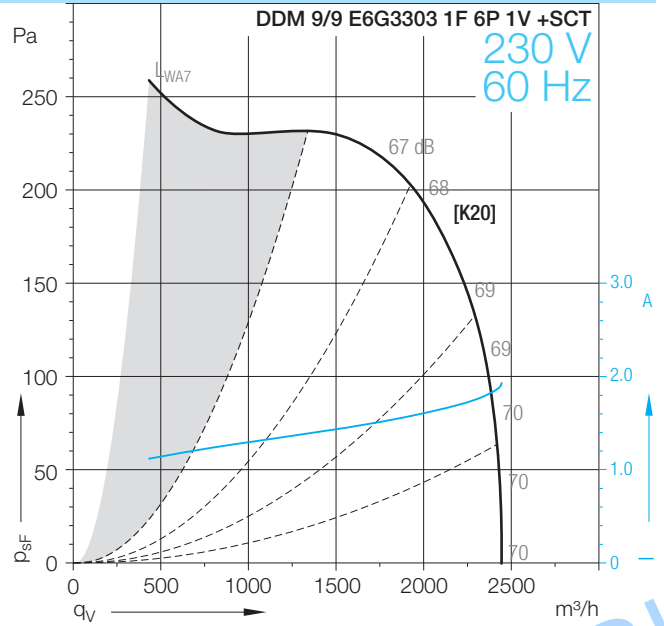
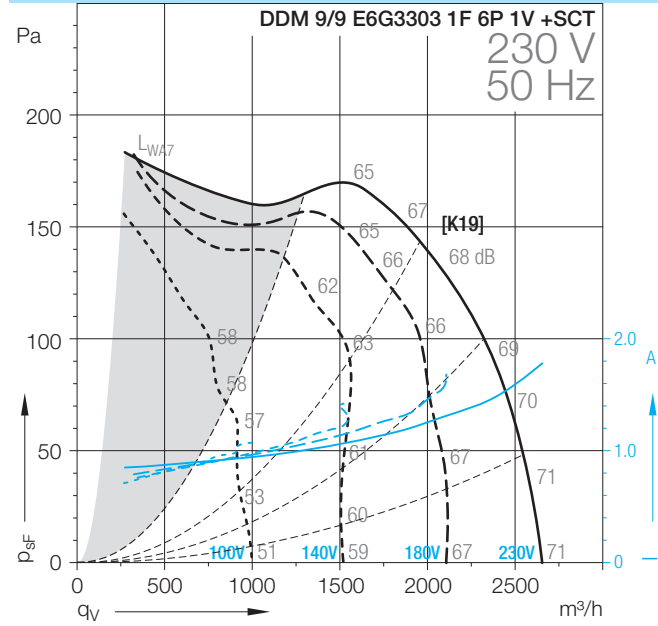

DDM-9/9

Technical Data										
	Speed control	Curves	Nominal motor power	Poles	Phases	Connection	Mains frequency	Max. power consumption	Max. current consumption	Speed
DDM 9/9			W	-			Hz	W	A	1/min
E6G3303 1F 6P 1V +SCT	(2)	[K19/K20]	200	6	1~		50/60	407	1.8	840
E6G3306 1F 6P 3V +SCT	*	[K21/K22]	200	6	1~		50/60	478	2	830
E6G3403 3F 6P 1V +SCT	*	[K23/K24]	245	6	3~	Δ/Y	50/60	552	1.2	870

Technical Data										
	Operating Capacitor	Nominal capacitor voltage	Motor protection class	Motor thermal class	Thermal protection	Media Temperature max.	Fan weight	Density of media	Installation type (ISO 5801)	Article number
DDM 9/9	μF	V				°C	kg	kg/m³		
E6G3303 1F 6P 1V +SCT	8	450	IP55	F	EXT	60	16	1.2	B	6M02M2
E6G3306 1F 6P 3V +SCT	10	450	IP44	F	EXT	40	14	1.2	B	6M02WU
E6G3403 3F 6P 1V +SCT			IP44	F	EXT	40	19	1.2	B	6M02G2

- (1) = Speed controllable via Transformer
- (2) = Speed controllable via TRIAC or Transformer
- (3) = Speed controllable via Inverter
- * = No speed control available

[HI] High speed, [ME] Medium speed, [LO] Low speed

Attention! We suggest to do not use the fan in the grey marked area! The noise ratings given in the performance curves are sound power level L_{WA7} , see „Technical Description“.

Dimensions in mm, subject to change.

DDM 9/9 E6G3303 1F 6P 1V +SCT

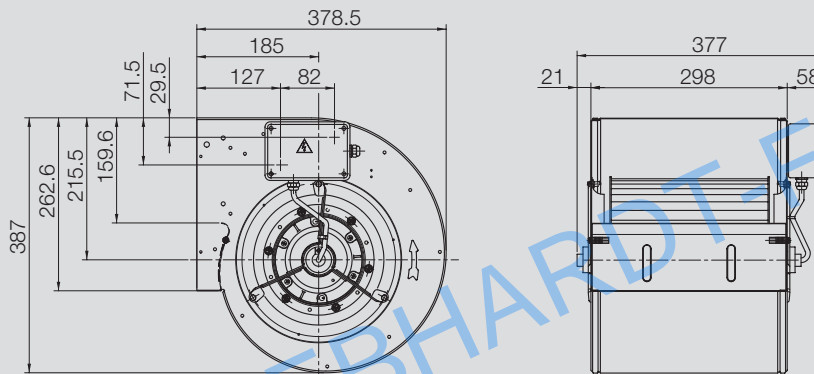

DDM 9/9 E6G3306 1F 4P 3V +SCT

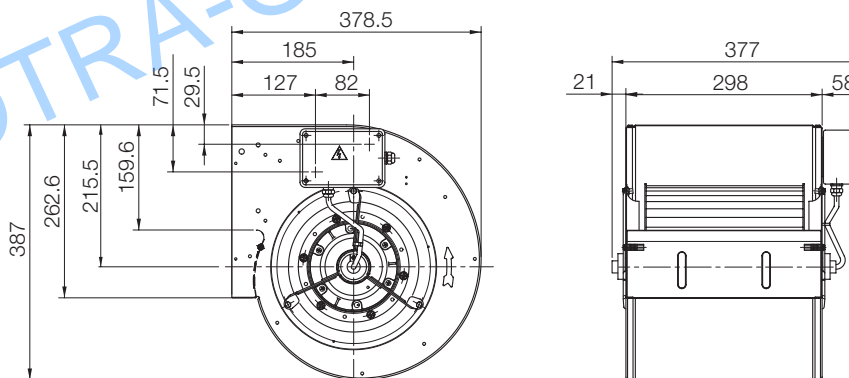

DDM 9/9 E6G3403 3F 6P 1V +SCT

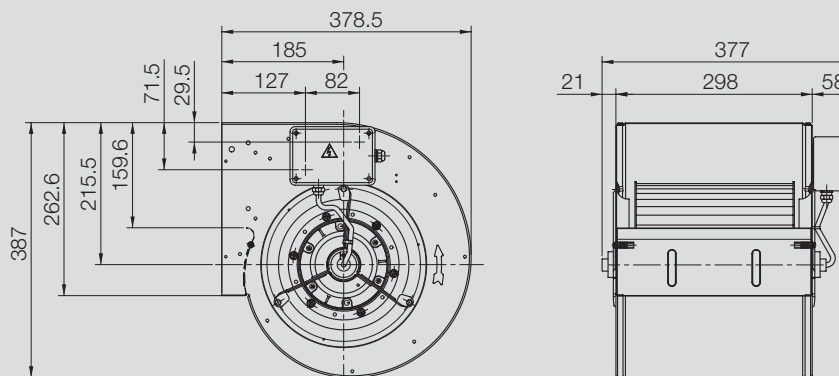

DDM-9/9 TIGHT

Technical Data

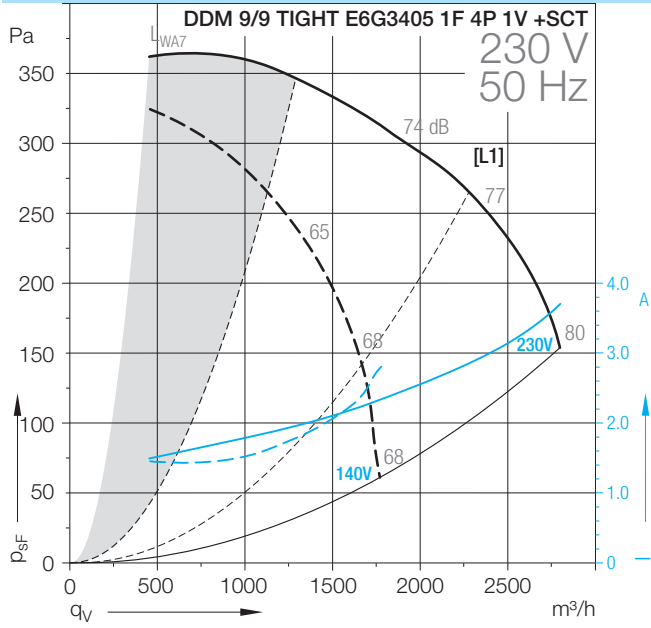

NICOTRA-GEBHARDT-FAN.RU

DDM-9/9 TIGHT

Technical Data										
	Speed control	Curves	Nominal motor power	Poles	Phases	Connection	Mains frequency	Max. power consumption	Max. current consumption	Speed
			W	-			Hz	W	A	1/min
DDM 9/9 TIGHT										
E6G3405 1F 4P 1V +SCT	(2)	[L1]	420	4	1~		50	865	3.8	1320

Technical Data										
	Operating Capacitor	Nominal capacitor voltage	Motor protection class	Motor thermal class	Thermal protection	Media Temperature max.	Fan weight	Density of media	Installation type (ISO 5801)	Article number
	µF	V				°C	kg	kg/m³		
DDM 9/9 TIGHT										
E6G3405 1F 4P 1V +SCT	16	450	IP55	F	EXT	40	15	1.2	B	6M02L8

- (1) = Speed controllable via Transformer
- (2) = Speed controllable via TRIAC or Transformer
- (3) = Speed controllable via Inverter
- * = No speed control available

[HI] High speed, [ME] Medium speed, [LO] Low speed
Attention! We suggest to do not use the fan in the grey marked area! The noise ratings given in the performance curves are sound power level L_{WA7} , see „Technical Description“.

Dimensions in mm, subject to change.

DDM 9/9 TIGHT E6G3405 1F 4P 1V +SCT

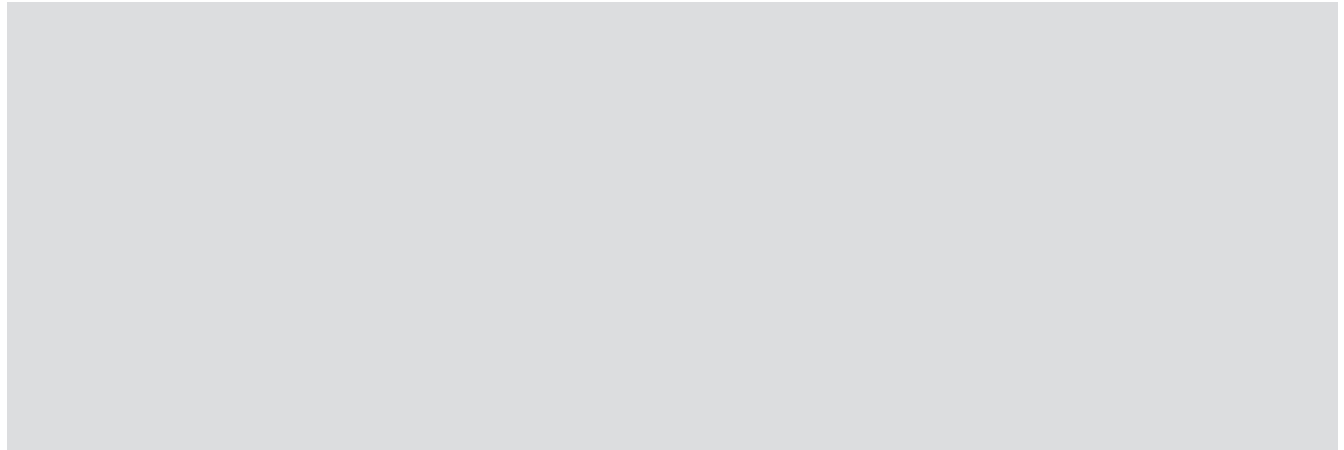
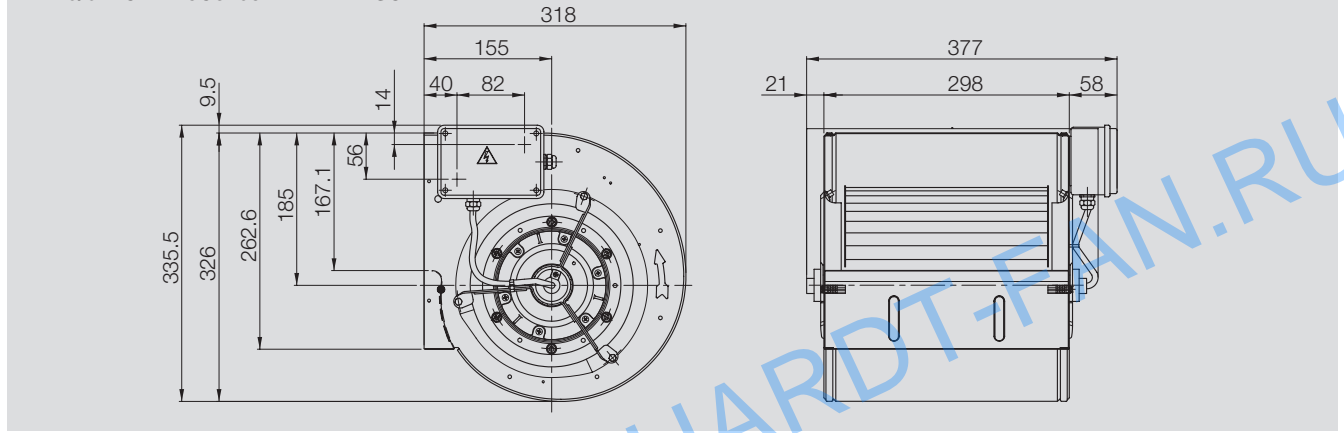

DDM-10/8

Technical Data

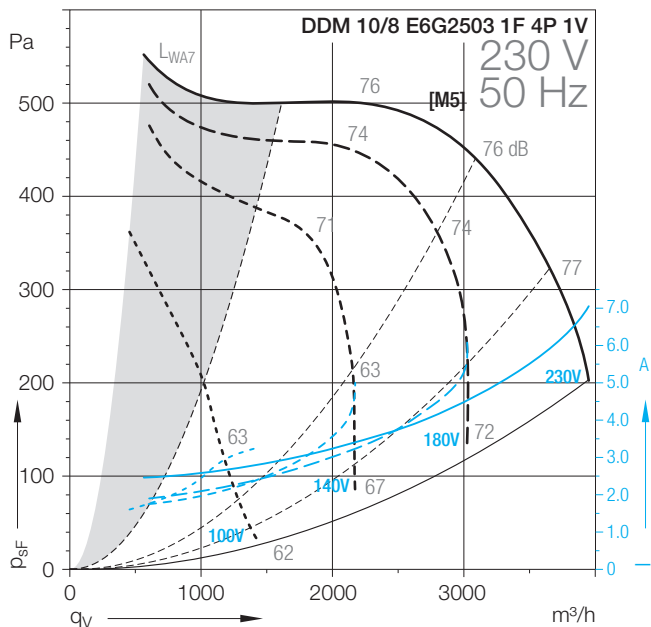
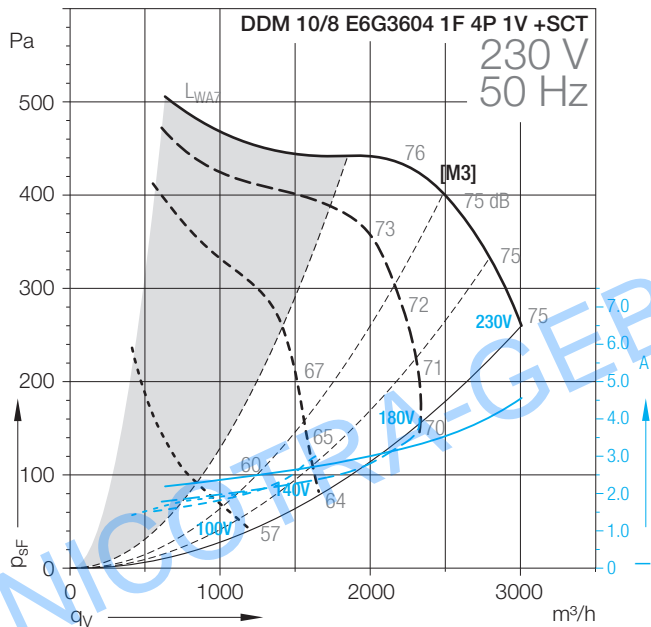
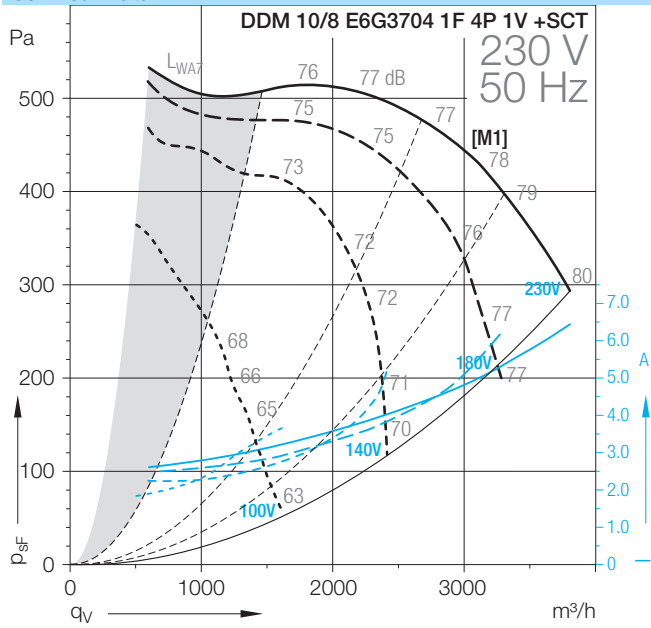

DDM-10/8

Technical Data										
	Speed control	Curves	Nominal motor power	Poles	Phases	Connection	Mains frequency	Max. power consumption	Max. current consumption	Speed
DDM 10/8			W	-			Hz	W	A	1/min
E6G3704 1F 4P 1V +SCT	(2)	[M1]	600	4	1~		50	1510	6.4	1380
E6G3604 1F 4P 1V +SCT	(2)	[M3]	550	4	1~		50	1061	4.6	1220
E6G2503 1F 4P 1V	(2)	[M5]	550	4	1~		50	1645	6.7	1400

Technical Data										
	Operating Capacitor	Nominal capacitor voltage	Motor protection class	Motor thermal class	Thermal protection	Media Temperature max.	Fan weight	Density of media	Installation type (ISO 5801)	Article number
DDM 10/8	µF	V				°C	kg	kg/m³		
E6G3704 1F 4P 1V +SCT	25	450	IP55	F	EXT	40	23	1.2	B	6102Z0
E6G3604 1F 4P 1V +SCT	16	450	IP55	F	EXT	40	20	1.2	B	6M02X4
E6G2503 1F 4P 1V	20	450	IP10	F	EXT	40	18	1.2	B	6M025N

(1) = Speed controllable via Transformer

(2) = Speed controllable via TRIAC or Transformer

(3) = Speed controllable via Inverter

* = No speed control available

[H] High speed, [ME] Medium speed, [LO] Low speed

Attention! We suggest to do not use the fan in the grey marked area! The noise ratings given in the performance curves are sound power level L_{WA7} , see „Technical Description“.

Dimensions in mm, subject to change.

DDM 10/8 E6G3704 1F 4P 1V +SCT

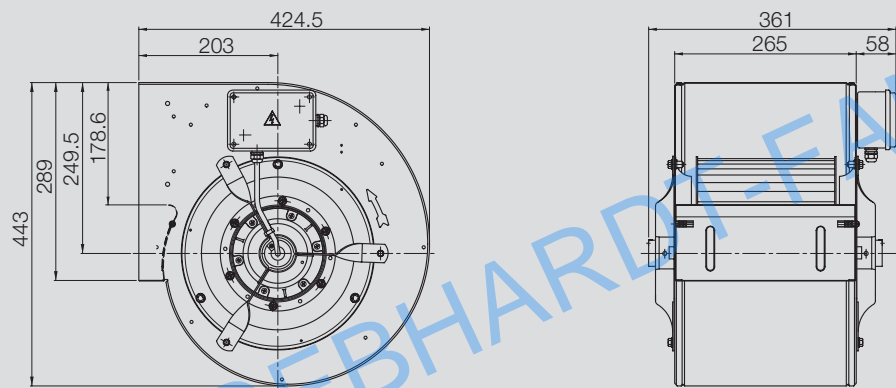

DDM 10/8 E6G3604 1F 4P 1V +SCT

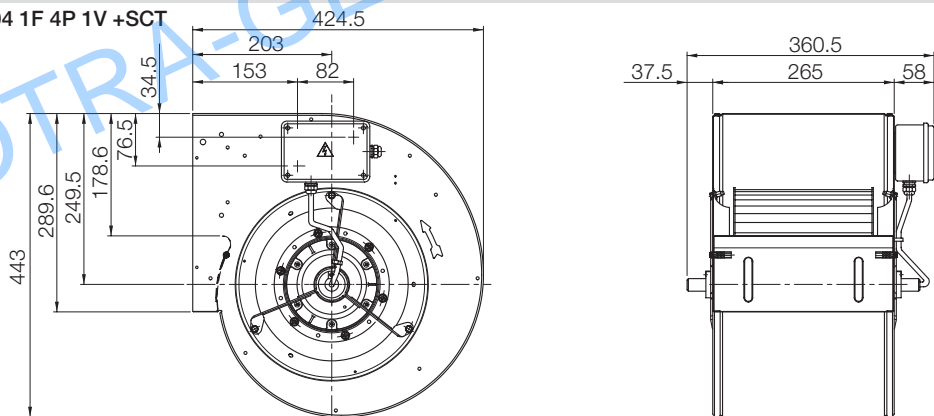

DDM 10/8 E6G2503 1F 4P 1V

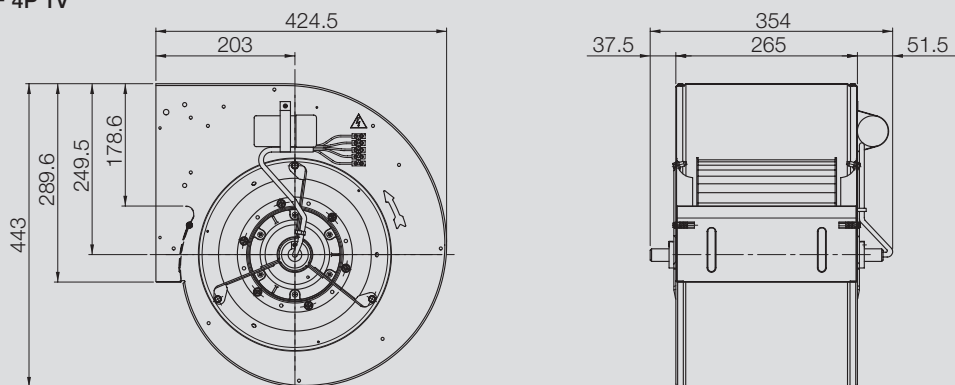

DDM-10/8

Technical Data

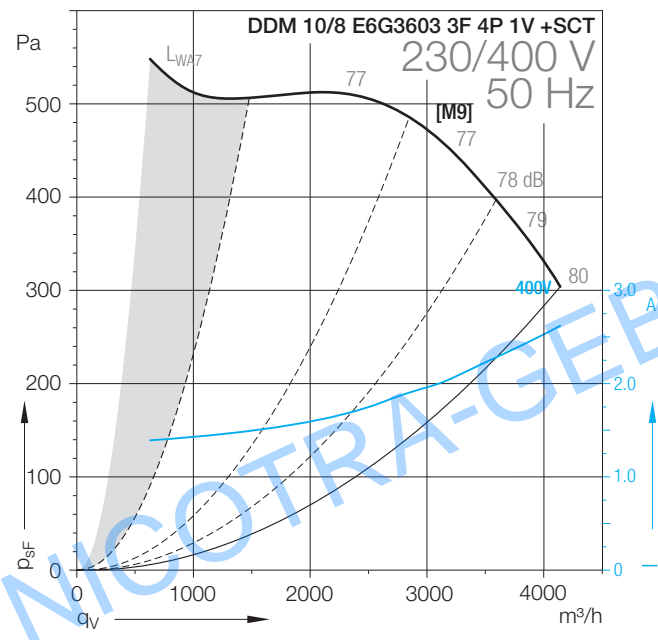
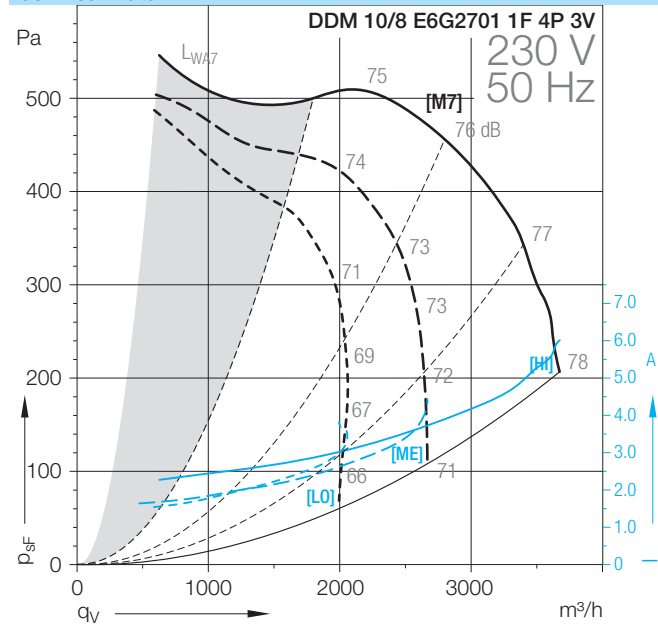

NICOTRA-GEBHARDT-FAN.RU

DDM-10/8

Technical Data										
	Speed control	Curves	Nominal motor power	Poles	Phases	Connection	Mains frequency	Max. power consumption	Max. current consumption	Speed
DDM 10/8			W	-			Hz	W	A	1/min
E6G2701 1F 4P 3V	*	[M7]	550	4	1~		50	1422	5.9	1380
E6G3603 3F 4P 1V +SCT	*	[M9]	550	4	3~	Δ/Y	50	1376	2.5	1410

Technical Data										
DDM 10/8	Operating Capacitor	Nominal capacitor voltage	Motor protection class	Motor thermal class	Thermal protection	Media Temperature max.	Fan weight	Density of media	Installation type (ISO 5801)	Article number
	μF	V				°C	kg	kg/m³		
E6G2701 1F 4P 3V	25	450	IP10	F	EXT	40	18	1.2	B	61025P
E6G3603 3F 4P 1V +SCT			IP55	F	EXT	40	24	1.2	B	6M02XA

(1) = Speed controllable via Transformer

(2) = Speed controllable via TRIAC or Transformer

(3) = Speed controllable via Inverter

* = No speed control available

[HI] High speed, [ME] Medium speed, [LO] Low speed

Attention! We suggest to do not use the fan in the grey marked area! The noise ratings given in the performance curves are sound power level L_{WA7} , see „Technical Description“.

Dimensions in mm, subject to change.

DDM 10/8 E6G2701 1F 4P 3V

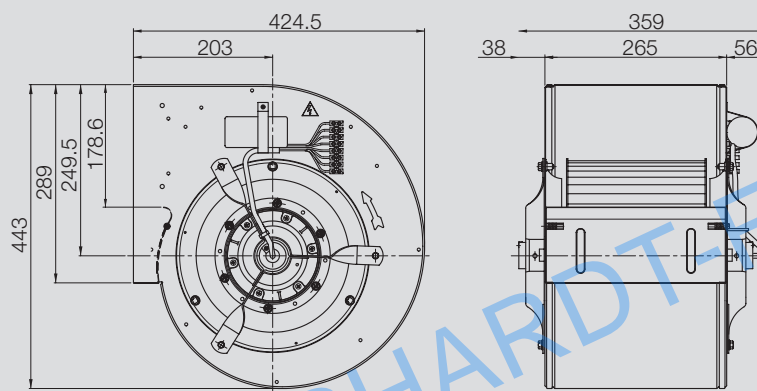

DDM 10/8 E6G3603 3F 4P 1V +SCT

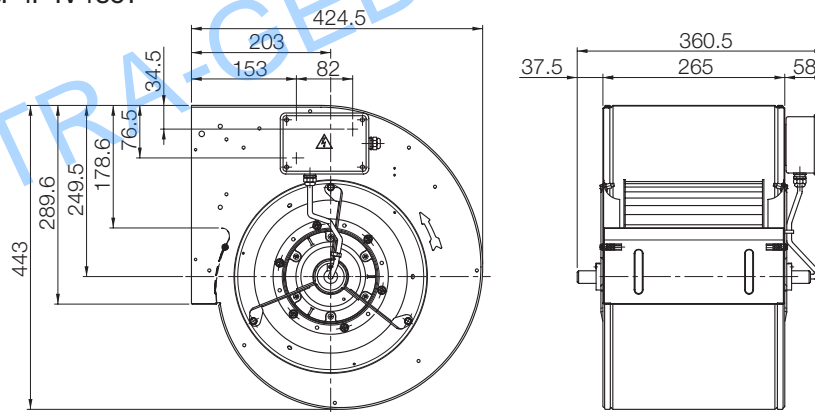

DDM-10/8

Technical Data										
	Speed control	Curves	Nominal motor power	Poles	Phases	Connection	Mains frequency	Max. power consumption	Max. current consumption	Speed
DDM 10/8			W	-			Hz	W	A	1/min
E6G3602 1F 6P 1V +SCT	(2)	[M11/M12]	515	6	1~		50/60	860	3.6	800
E6G3402 1F 6P 1V +SCT	(2)	[M13]	250	6	1~		50	533	2.3	800

Technical Data										
DDM 10/8	Operating Capacitor	Nominal capacitor voltage	Motor protection class	Motor thermal class	Thermal protection	Media Temperature max.	Fan weight	Density of media	Installation type (ISO 5801)	Article number
	µF	V				°C	kg	kg/m³		
E6G3602 1F 6P 1V +SCT	25	450	IP55	F	EXT	70	14	1.2	B	6M02N9
E6G3402 1F 6P 1V +SCT	12.5	450	IP55	F	EXT	40	17	1.2	B	6M02WZ

(1) = Speed controllable via Transformer

(2) = Speed controllable via TRIAC or Transformer

(3) = Speed controllable via Inverter

* = No speed control available

[HI] High speed, [ME] Medium speed, [LO] Low speed

Attention! We suggest to do not use the fan in the grey marked area! The noise ratings given in the performance curves are sound power level L_{WA7} , see „Technical Description“.

Dimensions in mm, subject to change.

DDM 10/8 E6G3602 1F 6P 1V +SCT

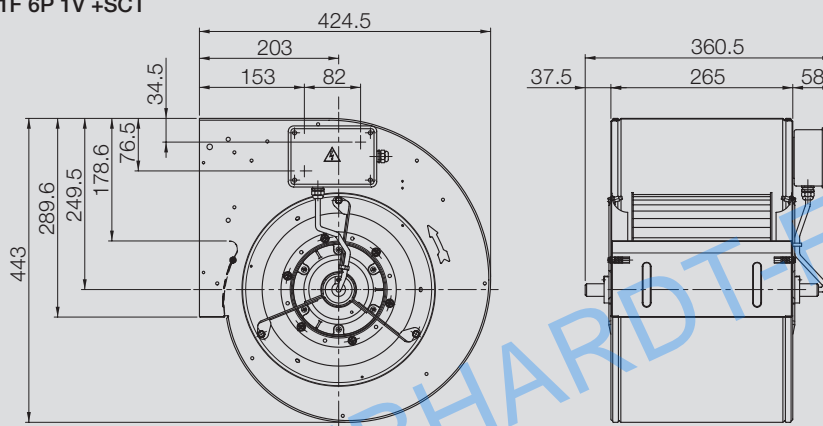

DDM 10/8 E6G3402 1F 6P 1V +SCT

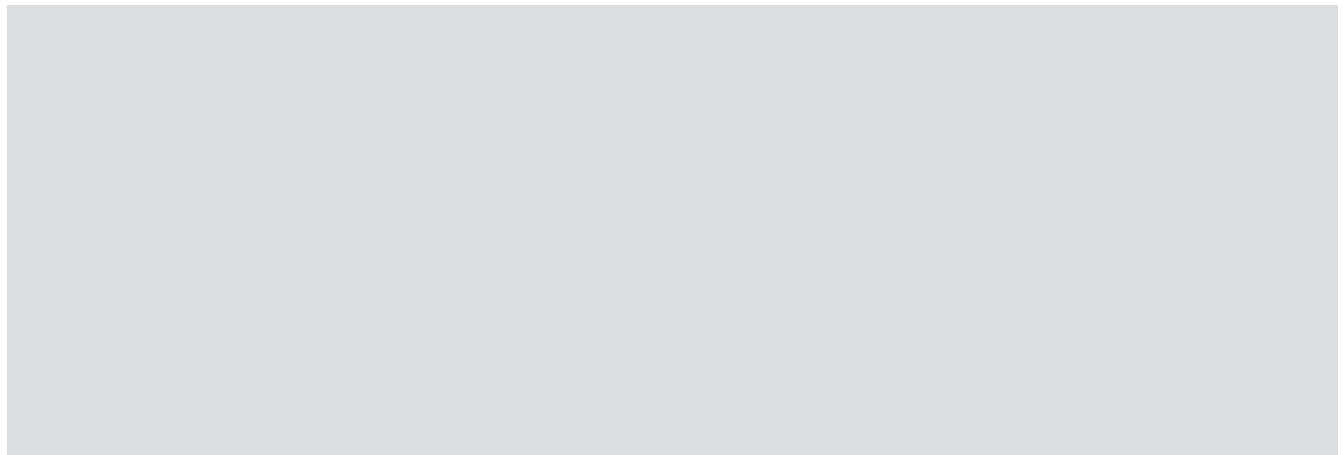
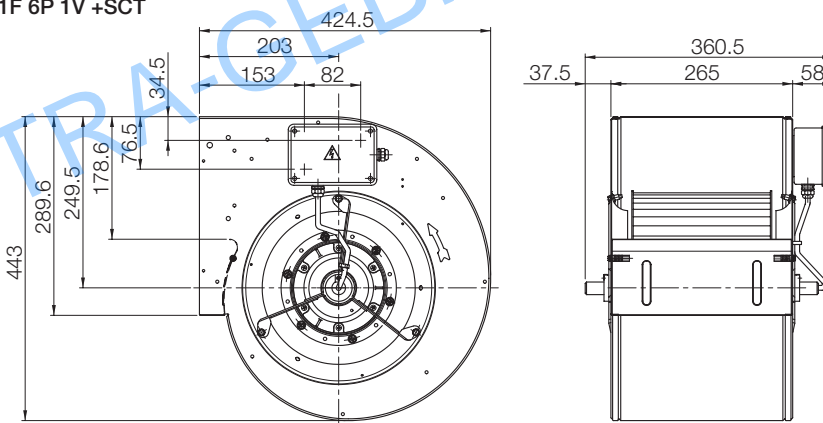

DDM-10/8

Technical Data										
	Speed control	Curves	Nominal motor power	Poles	Phases	Connection	Mains frequency	Max. power consumption	Max. current consumption	Speed
DDM 10/8			W	-			Hz	W	A	1/min
E6G2601 1F 6P 3V	*	[M15]	420	6	1~		50	926	4.3	890
E6G3404 1F 6P 3V +SCT	*	[M17]	280	6	1~		50	656	2.9	865
E6G3403 3F 6P 1V +SCT	*	[M19/M20]	245	6	3~	Δ/Y	50/60	659	1.3	870

Technical Data										
	Operating Capacitor	Nominal capacitor voltage	Motor protection class	Motor thermal class	Thermal protection	Media Temperature max.	Fan weight	Density of media	Installation type (ISO 5801)	Article number
DDM 10/8	μF	V				°C	kg	kg/m³		
E6G2601 1F 6P 3V	20	450	IP10	F	EXT	70	24	1.2	B	6M02LP
E6G3404 1F 6P 3V +SCT	12.5	450	IP55	F	EXT	40	15	1.2	B	6M024A
E6G3403 3F 6P 1V +SCT			IP44	F	EXT	40	24	1.2	B	6M02XC

(1) = Speed controllable via Transformer

(2) = Speed controllable via TRIAC or Transformer

(3) = Speed controllable via Inverter

* = No speed control available

[HI] High speed, [ME] Medium speed, [LO] Low speed

Attention! We suggest to do not use the fan in the grey marked area! The noise ratings given in the performance curves are sound power level L_{WA7} , see „Technical Description“.

Dimensions in mm, subject to change.

DDM 10/8 E6G2601 1F 6P 3V

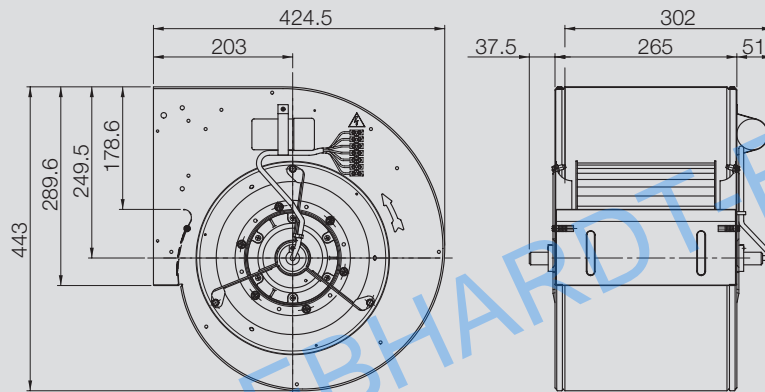

DDM 10/8 E6G3404 1F 6P 3V +SCT

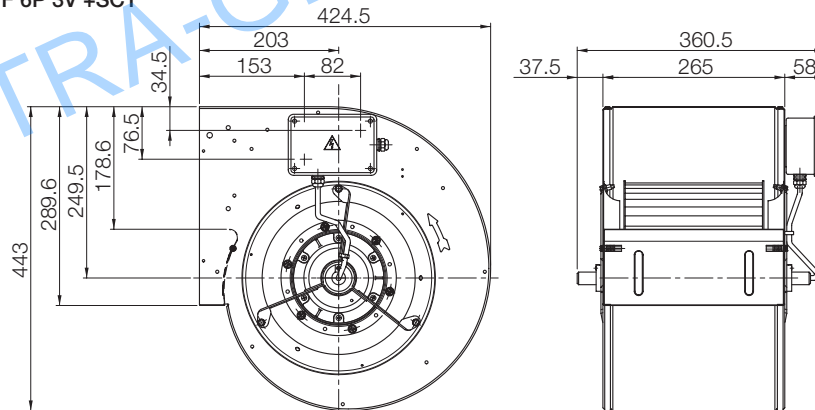

DDM 10/8 E6G3403 3F 6P 1V +SCT

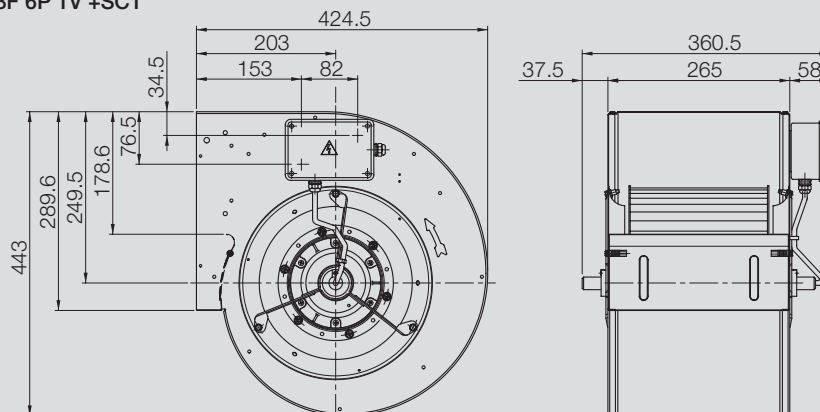

DDM-10/10

Technical Data

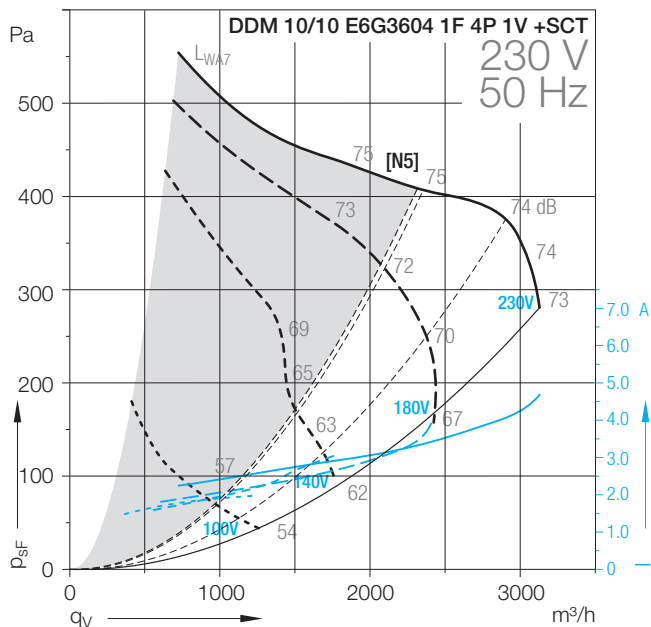
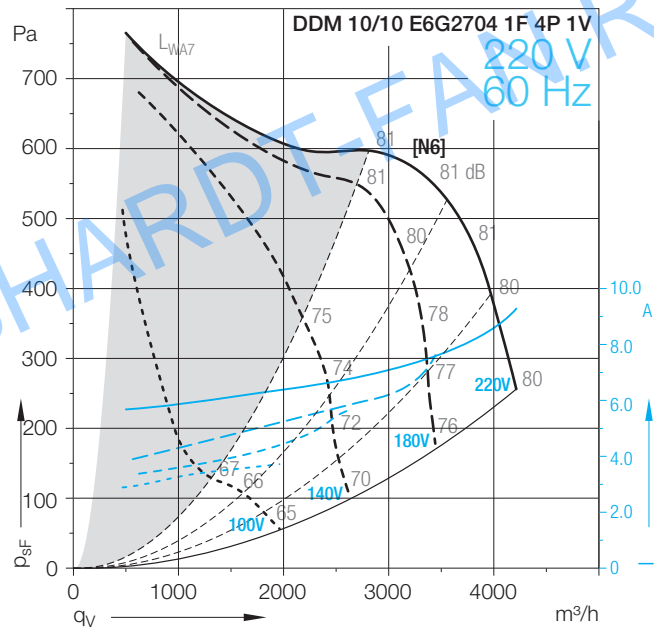
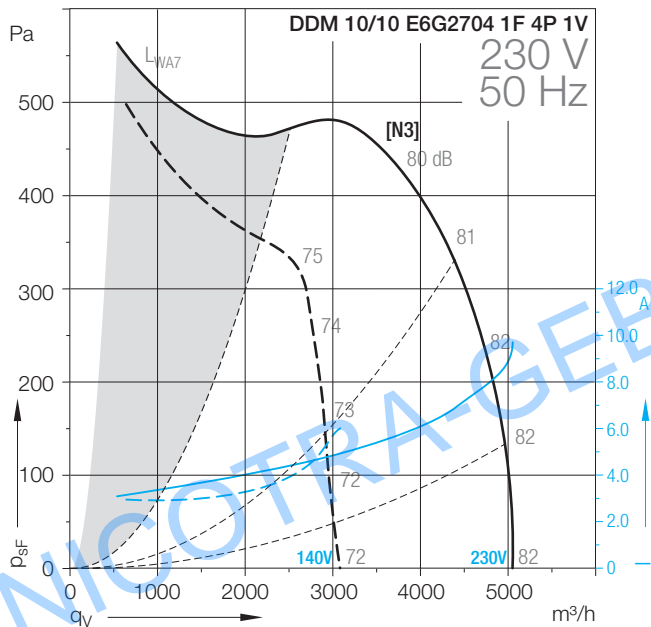
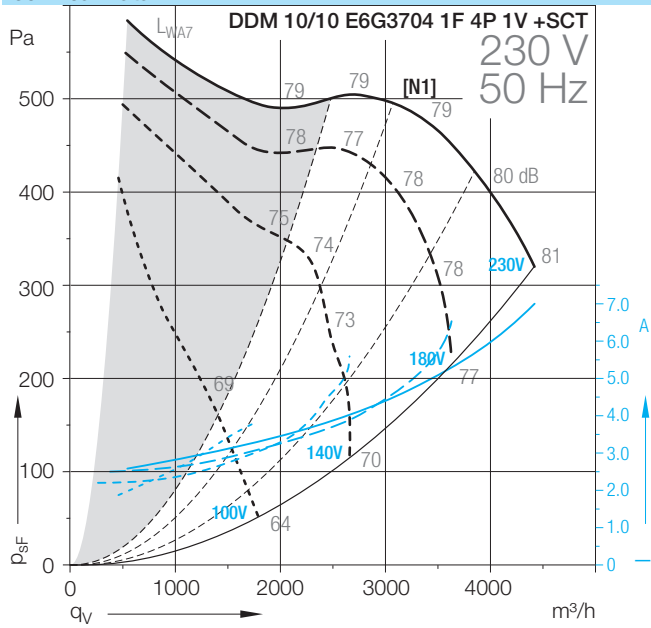

DDM-10/10

Technical Data										
	Speed control	Curves	Nominal motor power	Poles	Phases	Connection	Mains frequency	Max. power consumption	Max. current consumption	Speed
DDM 10/10			W	-			Hz	W	A	1/min
E6G3704 1F 4P 1V +SCT	(2)	[N1]	600	4	1~		50	1653	6.6	1380
E6G2704 1F 4P 1V	(2)	[N3/N4]	600	4	1~		50/60	2227	9.3	1380
E6G3604 1F 4P 1V +SCT	(2)	[N5]	550	4	1~		50	1069	4.6	1220

Technical Data										
	Operating Capacitor	Nominal capacitor voltage	Motor protection class	Motor thermal class	Thermal protection	Media Temperature max.	Fan weight	Density of media	Installation type (ISO 5801)	Article number
DDM 10/10	µF	V				°C	kg	kg/m³		
E6G3704 1F 4P 1V +SCT	25	450	IP55	F	EXT	40	24	1.2	B	6M02Z6
E6G2704 1F 4P 1V	30	450	IP10	F	EXT	40	26	1.2	B	6M02CY
E6G3604 1F 4P 1V +SCT	16	450	IP55	F	EXT	40	21	1.2	B	6M02P0

- (1) = Speed controllable via Transformer
- (2) = Speed controllable via TRIAC or Transformer
- (3) = Speed controllable via Inverter
- * = No speed control available

[HI] High speed, [ME] Medium speed, [LO] Low speed

Attention! We suggest to do not use the fan in the grey marked area! The noise ratings given in the performance curves are sound power level L_{WA7} , see „Technical Description“.

Dimensions in mm, subject to change.

DDM 10/10 E6G3704 1F 4P 1V +SCT

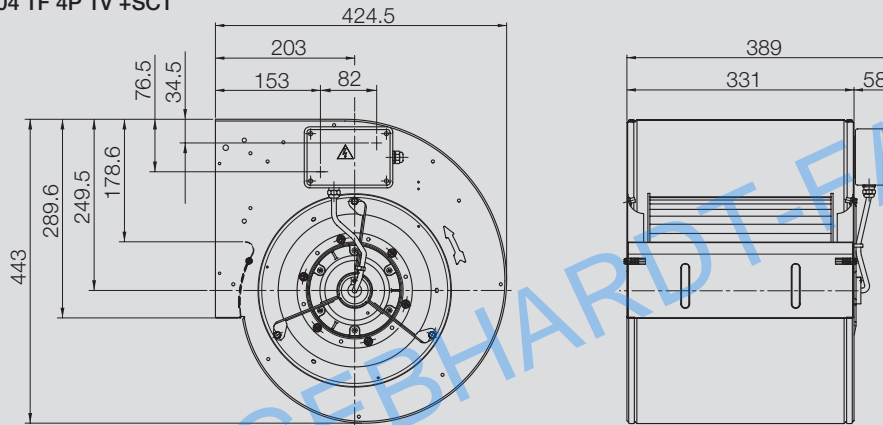

DDM 10/10 E6G2704 1F 4P 1V

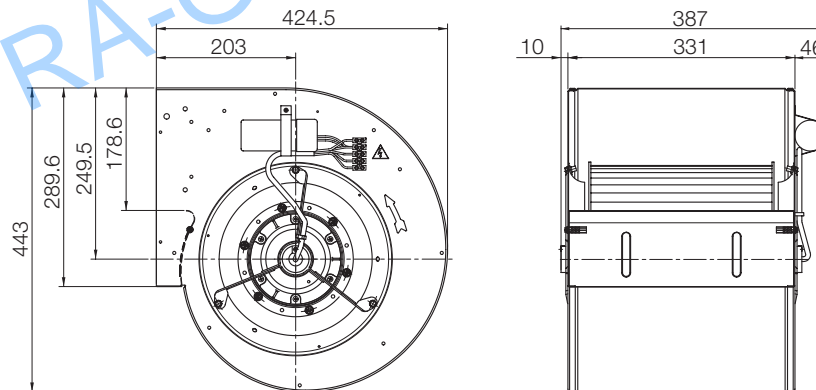

DDM 10/10 E6G3604 1F 4P 1V +SCT

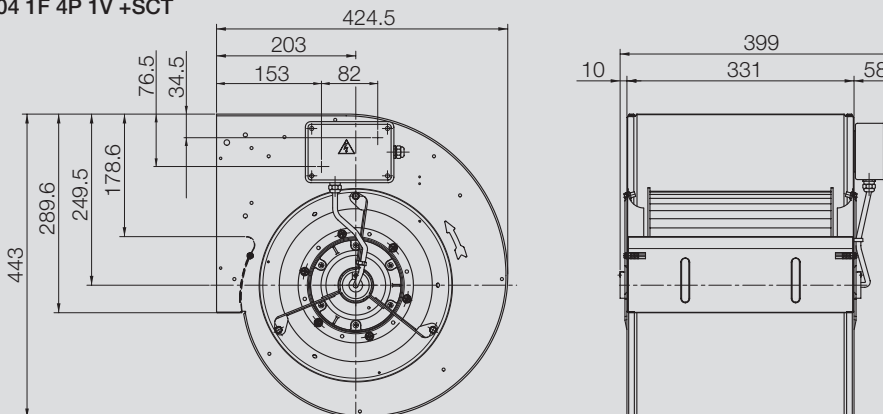

DDM-10/10

Technical Data										
	Speed control	Curves	Nominal motor power	Poles	Phases	Connection	Mains frequency	Max. power consumption	Max. current consumption	Speed
DDM 10/10			W	-			Hz	W	A	1/min
E6G2503 1F 4P 1V	(2)	[N7]	550	4	1~		50	1542	6.5	1400
E6G2701 1F 4P 3V	*	[N9]	550	4	1~		50	1398	5.7	1380

Technical Data										
	Operating Capacitor	Nominal capacitor voltage	Motor protection class	Motor thermal class	Thermal protection	Media Temperature max.	Fan weight	Density of media	Installation type (ISO 5801)	Article number
DDM 10/10	µF	V				°C	kg	kg/m³		
E6G2503 1F 4P 1V	25	450	IP10	F	EXT	40	16	1.2	B	6M02XF
E6G2701 1F 4P 3V	25	450	IP10	F	EXT	40	23	1.2	B	6M02Z8

(1) = Speed controllable via Transformer

(2) = Speed controllable via TRIAC or Transformer

(3) = Speed controllable via Inverter

* = No speed control available

[HI] High speed, [ME] Medium speed, [LO] Low speed

Attention! We suggest to do not use the fan in the grey marked area! The noise ratings given in the performance curves are sound power level L_{WA7} , see „Technical Description“.

Dimensions in mm, subject to change.

DDM 10/10 E6G2503 1F 4P 1V

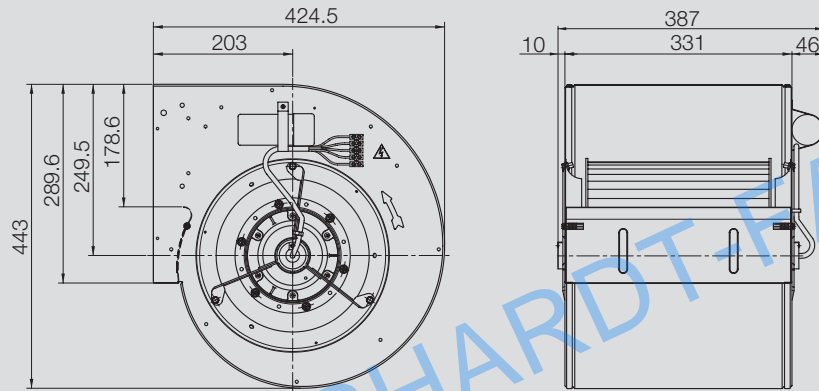

DDM 10/10 E6G2701 1F 4P 3V

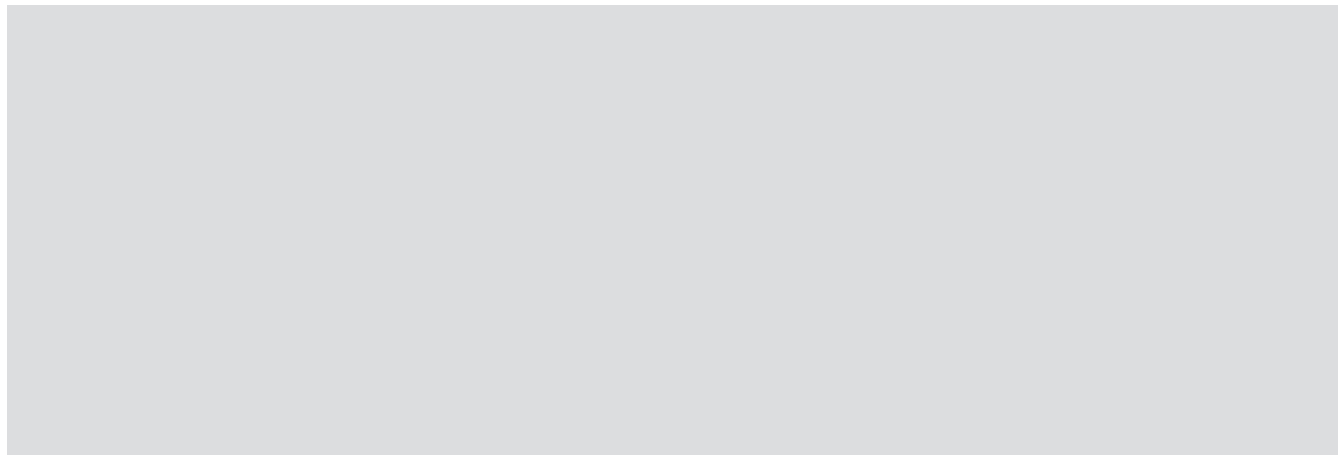
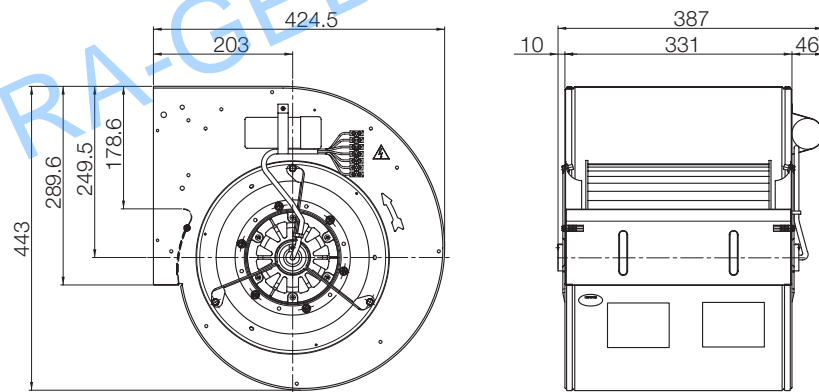

DDM-10/10

Technical Data

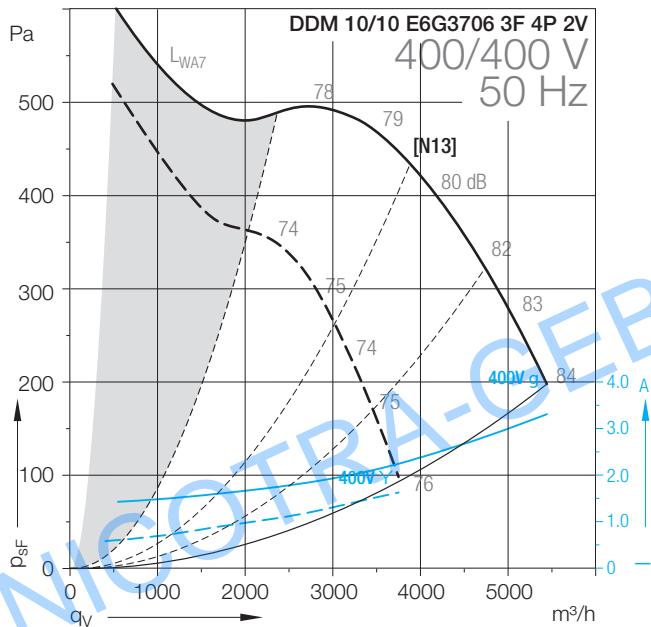
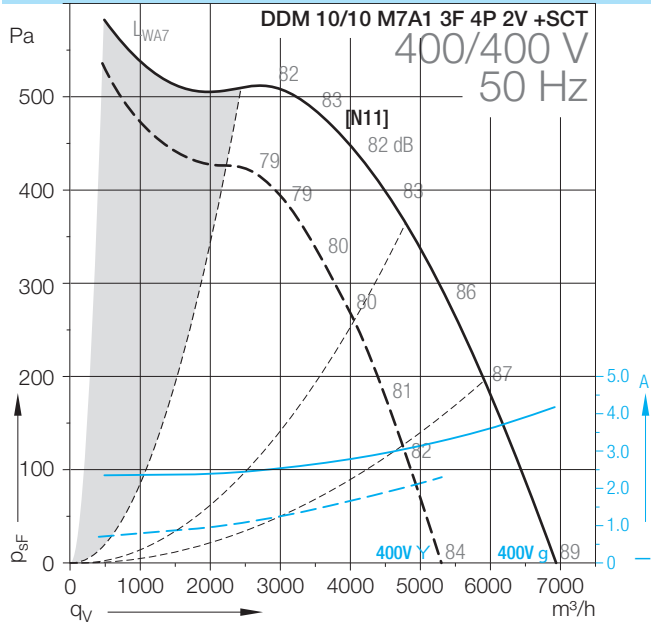

NICOTRA-GEBHARDT-FAN.RU

DDM-10/10

Technical Data										
	Speed control	Curves	Nominal motor power	Poles	Phases	Connection	Mains frequency	Max. power consumption	Max. current consumption	Speed
DDM 10/10			W	-			Hz	W	A	1/min
M7A1 3F 4P 2V +SCT	(2)/(3)	[N11]	1000	4	3~	Δ/Y	50	2555	4.2	1220
E6G3706 3F 4P 2V +SCT	(1)	[N13]	750	4	3~	Δ/Y	50	1888	3.3	1370

Technical Data										
	Operating Capacitor	Nominal capacitor voltage	Motor protection class	Motor thermal class	Thermal protection	Media Temperature max.	Fan weight	Density of media	Installation type (ISO 5801)	Article number
DDM 10/10						°C	kg	kg/m³		
M7A1 3F 4P 2V +SCT			IP54	F	INT	40	21	1.2	B	6M0212Z
E6G3706 3F 4P 2V +SCT			IP55	F	EXT	40	18	1.2	B	6M021Y

(1) = Speed controllable via Transformer

(2) = Speed controllable via TRIAC or Transformer

(3) = Speed controllable via Inverter

* = No speed control available

[HI] High speed, [ME] Medium speed, [LO] Low speed

Attention! We suggest to do not use the fan in the grey marked area! The noise ratings given in the performance curves are sound power level L_{WA7} , see „Technical Description“.

Dimensions in mm, subject to change.

DDM 10/10 M7A1 3F 4P 2V +SCT

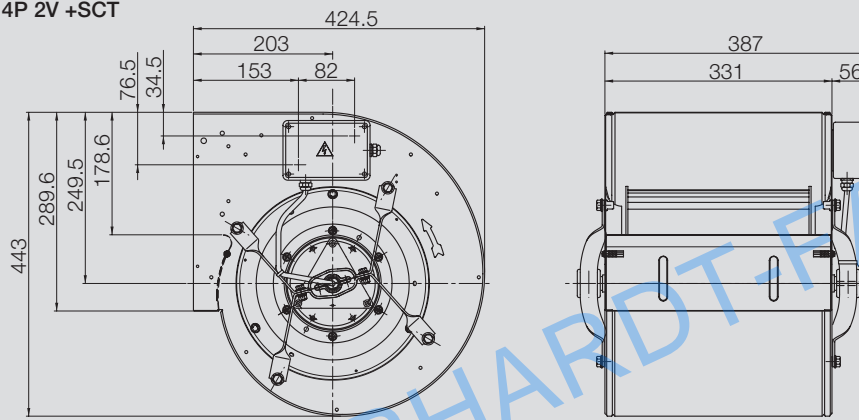

DDM 10/10 E6G3706 3F 4P 2V +SCT

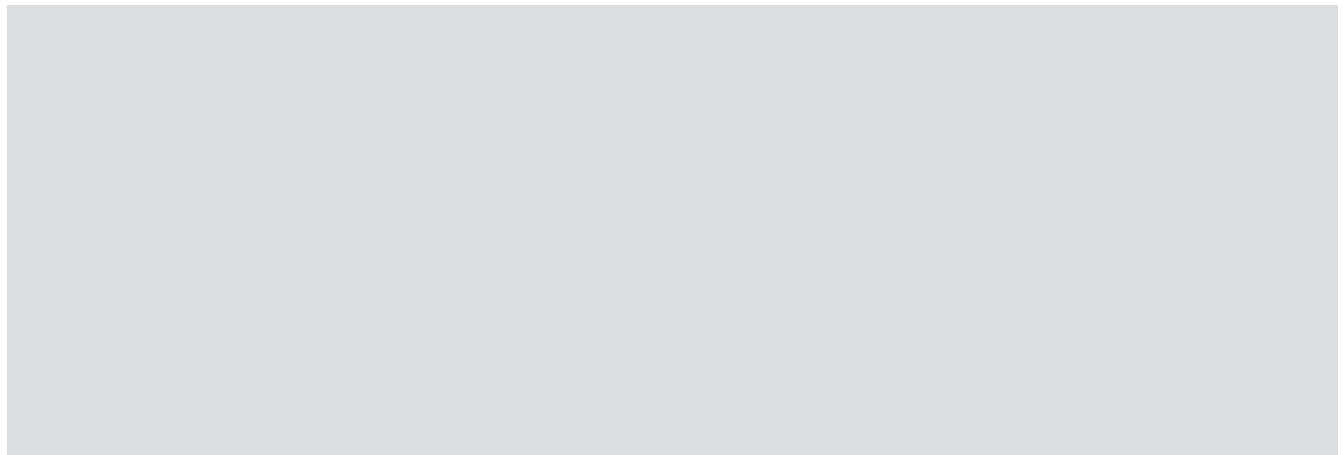
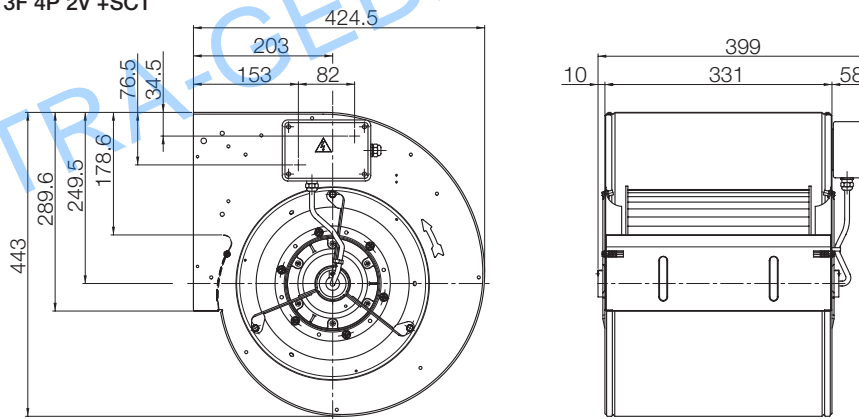

DDM-10/10

Technical Data

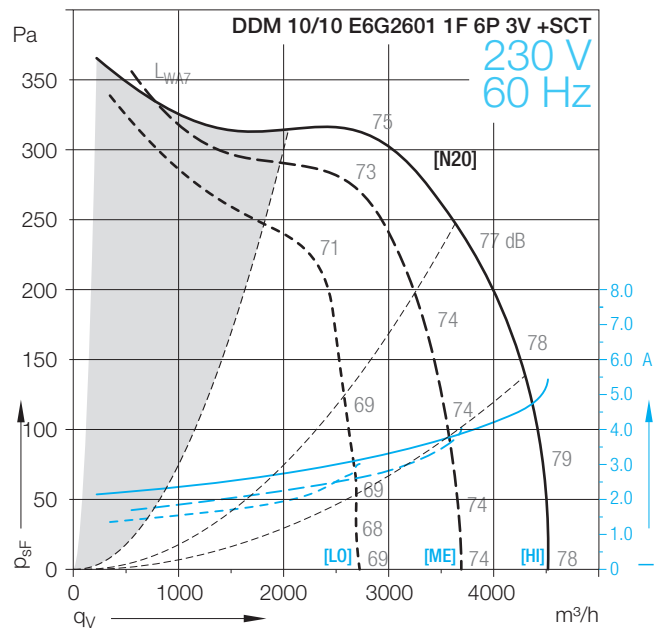
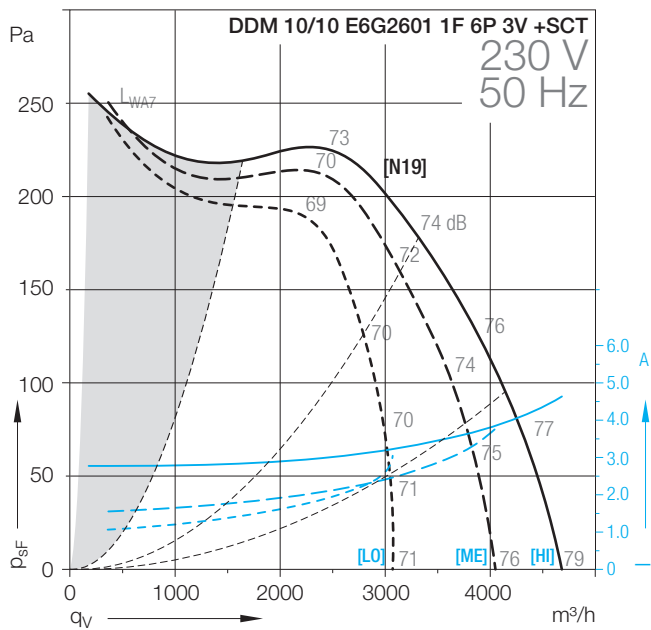
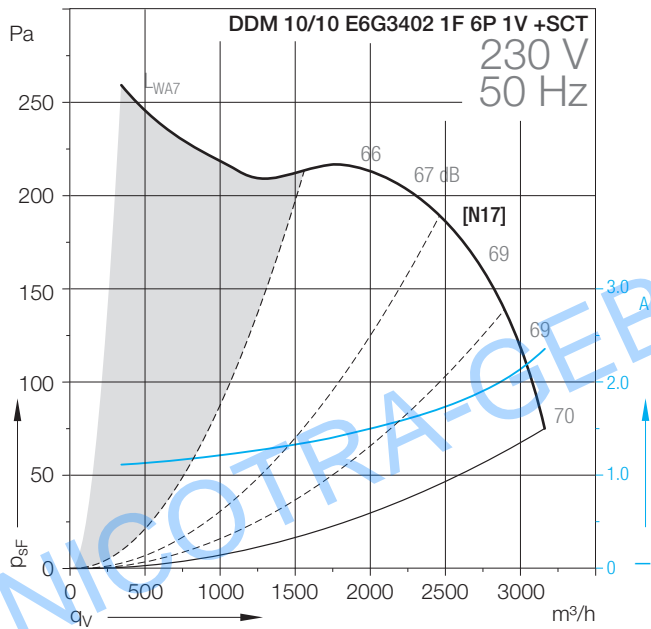
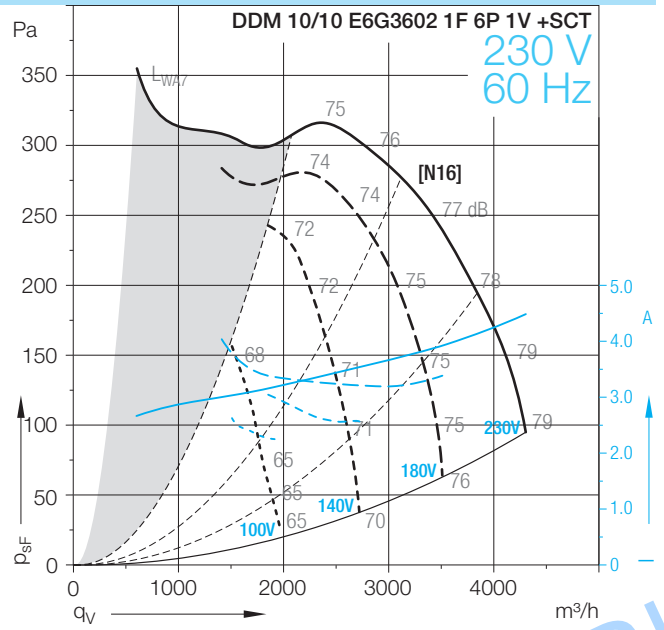
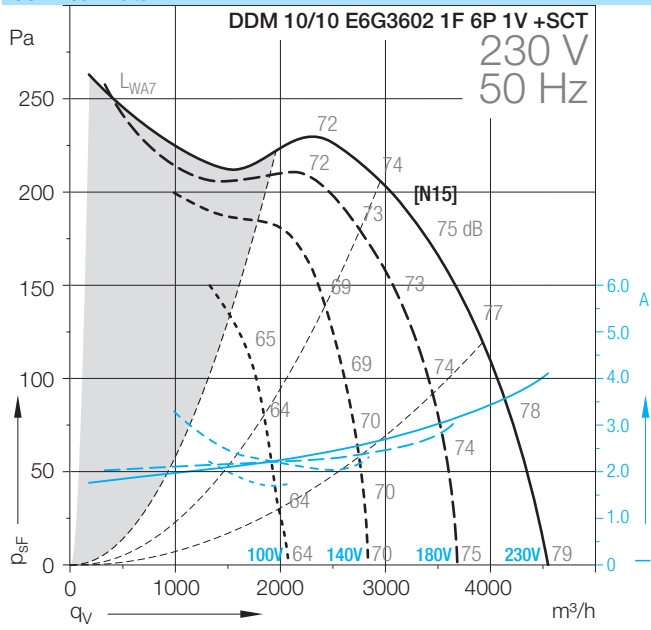

DDM-10/10

Technical Data										
	Speed control	Curves	Nominal motor power	Poles	Phases	Connection	Mains frequency	Max. power consumption	Max. current consumption	Speed
DDM 10/10			W	-			Hz	W	A	1/min
E6G3602 1F 6P 1V +SCT	(2)	[N15/N16]	515	6	1~		50/60	952	3.8	800
E6G3402 1F 6P 1V +SCT	(2)	[N17]	250	6	1~		50	564	2.3	800
E6G2601 1F 6P 3V	*	[N19/N20]	420	6	1~		50	1035	5	890

Technical Data										
	Operating Capacitor	Nominal capacitor voltage	Motor protection class	Motor thermal class	Thermal protection	Media Temperature max.	Fan weight	Density of media	Installation type (ISO 5801)	Article number
DDM 10/10	µF	V				°C	kg	kg/m³		
E6G3602 1F 6P 1V +SCT	25	450	IP55	F	EXT	50	21	1.2	B	6M02N1
E6G3402 1F 6P 1V +SCT	12.5	450	IP55	F	EXT	40	22	1.2	B	6M02GA
E6G2601 1F 6P 3V	20	450	IP10	F	EXT	60	24	1.2	B	6M02FF

- (1) = Speed controllable via Transformer
- (2) = Speed controllable via TRIAC or Transformer
- (3) = Speed controllable via Inverter
- * = No speed control available

[HI] High speed, [ME] Medium speed, [LO] Low speed

Attention! We suggest to do not use the fan in the grey marked area! The noise ratings given in the performance curves are sound power level L_{WA7} , see „Technical Description“.

Dimensions in mm, subject to change.

DDM 10/10 E6G3602 1F 6P 1V +SCT

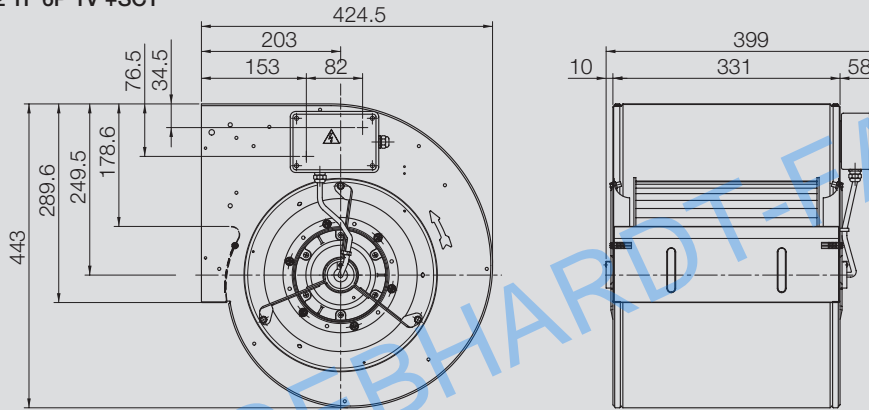

DDM 10/10 E6G3402 1F 6P 1V +SCT

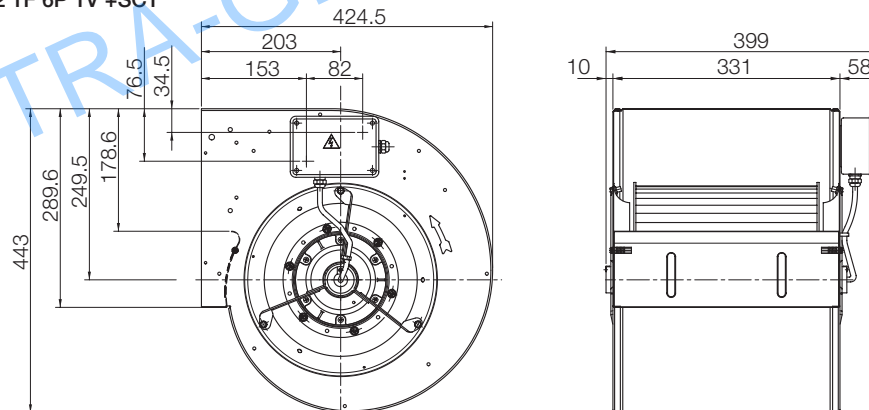

DDM 10/10 E6G2601 1F 6P 3V

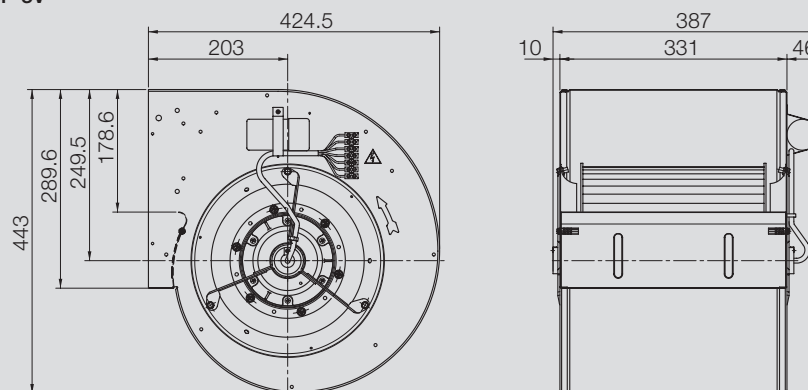

DDM-10/10

Technical Data

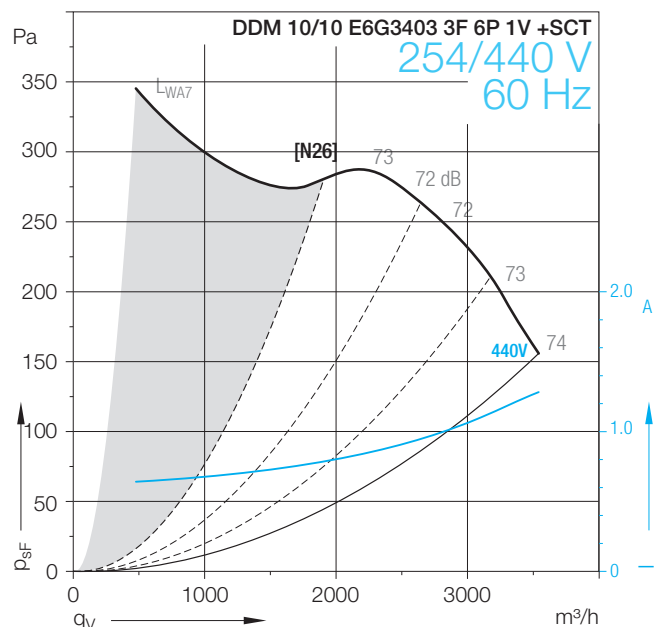
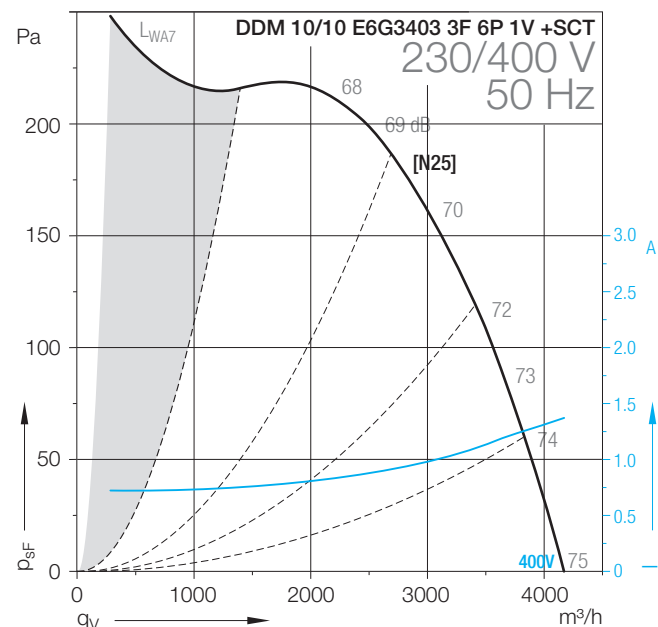
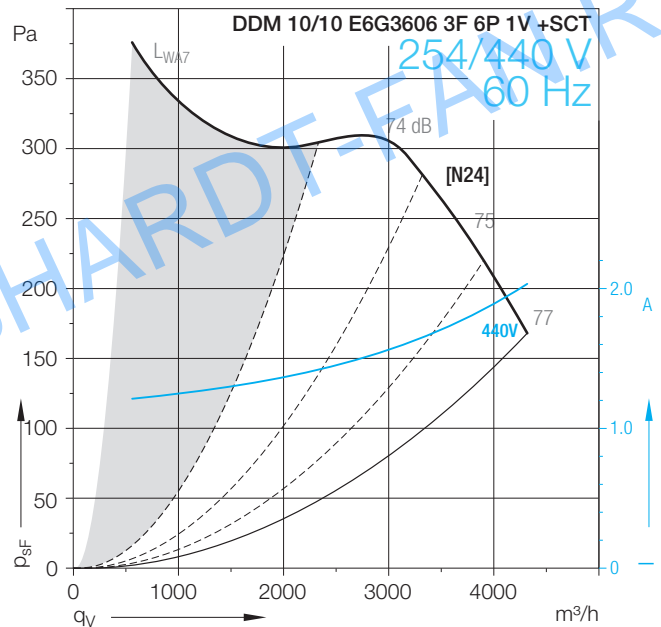
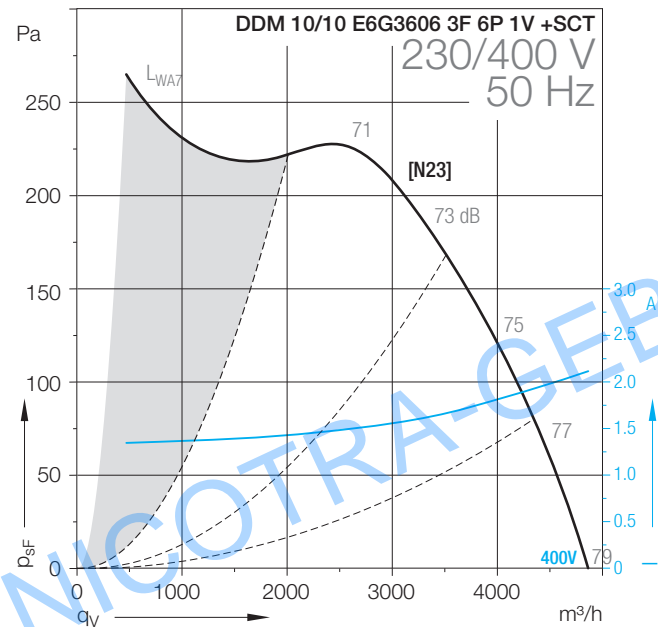
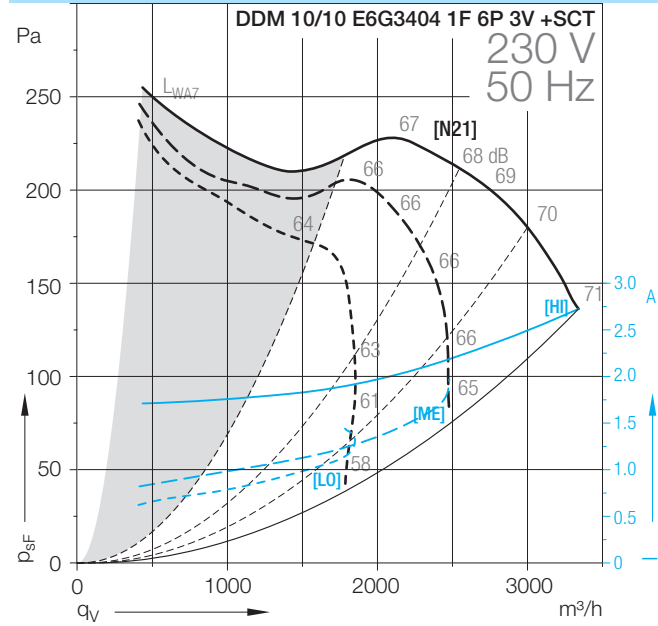

DDM-10/10

Technical Data										
	Speed control	Curves	Nominal motor power	Poles	Phases	Connection	Mains frequency	Max. power consumption	Max. current consumption	Speed
DDM 10/10			W	-			Hz	W	A	1/min
E6G3404 1F 6P 3V +SCT	*	[N21]	280	6	1~		50	620	2.7	865
E6G3606 3F 6P 1V +SCT	*	[N23/N24]	350	6	3~	Δ/Y	50/60	1049	2	900
E6G3403 3F 6P 1V +SCT	*	[N25/N26]	245	6	3~	Δ/Y	50/60	783	1.3	870

Technical Data										
	Operating Capacitor	Nominal capacitor voltage	Motor protection class	Motor thermal class	Thermal protection	Media Temperature max.	Fan weight	Density of media	Installation type (ISO 5801)	Article number
DDM 10/10	μF	V				°C	kg	kg/m³		
E6G3404 1F 6P 3V +SCT	12.5	450	IP44	F	EXT	40	23	1.2	B	6M02XM
E6G3606 3F 6P 1V +SCT			IP55	F	EXT	40	24	1.2	B	6M025T
E6G3403 3F 6P 1V +SCT			IP44	F	EXT	40	24	1.2	B	6M02G3

- (1) = Speed controllable via Transformer
- (2) = Speed controllable via TRIAC or Transformer
- (3) = Speed controllable via Inverter
- * = No speed control available

[H] High speed, [ME] Medium speed, [LO] Low speed
Attention! We suggest to do not use the fan in the grey marked area! The noise ratings given in the performance curves are sound power level L_{WA7} , see „Technical Description“.

Dimensions in mm, subject to change.

DDM 10/10 E6G3404 1F 6P 3V +SCT

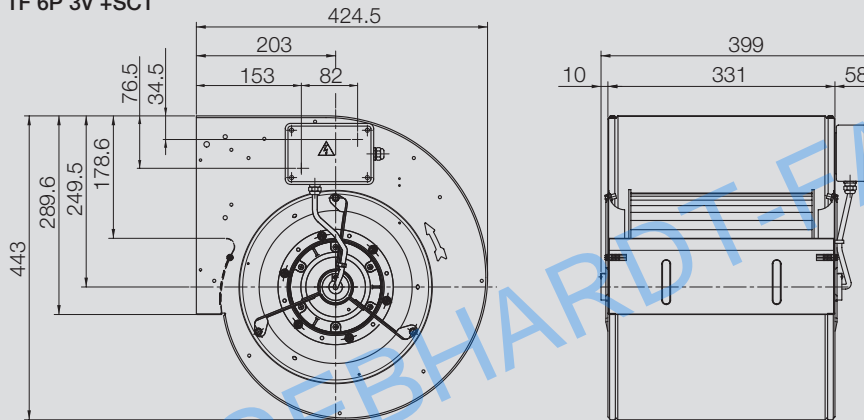

DDM 10/10 E6G3606 3F 6P 1V +SCT

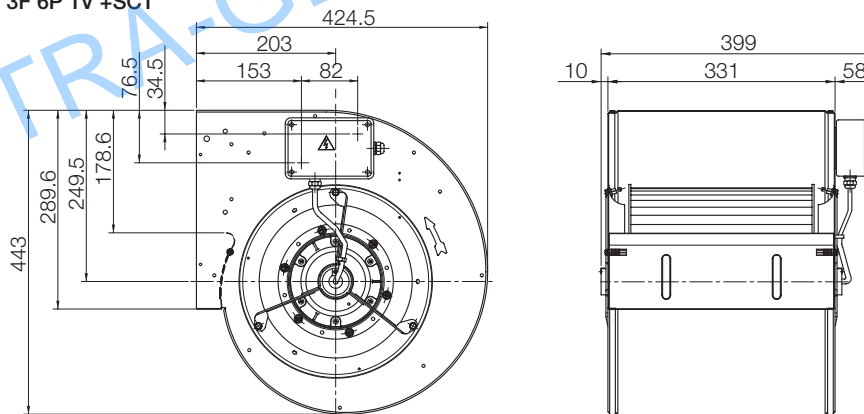

DDM 10/10 E6G3403 3F 6P 1V +SCT

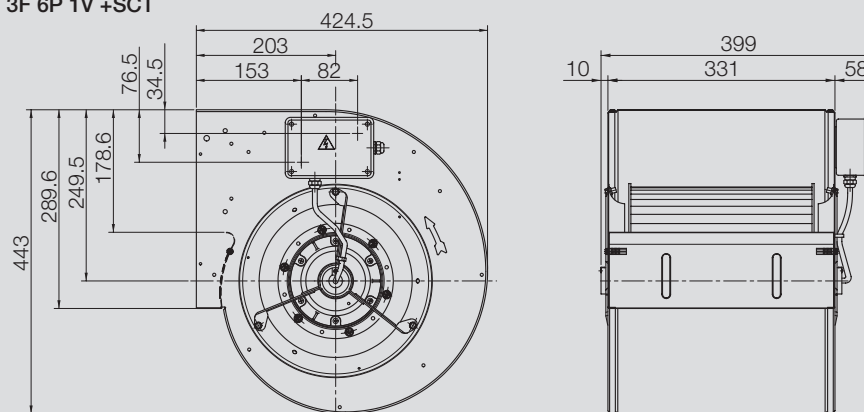

DDM-12/9

Technical Data

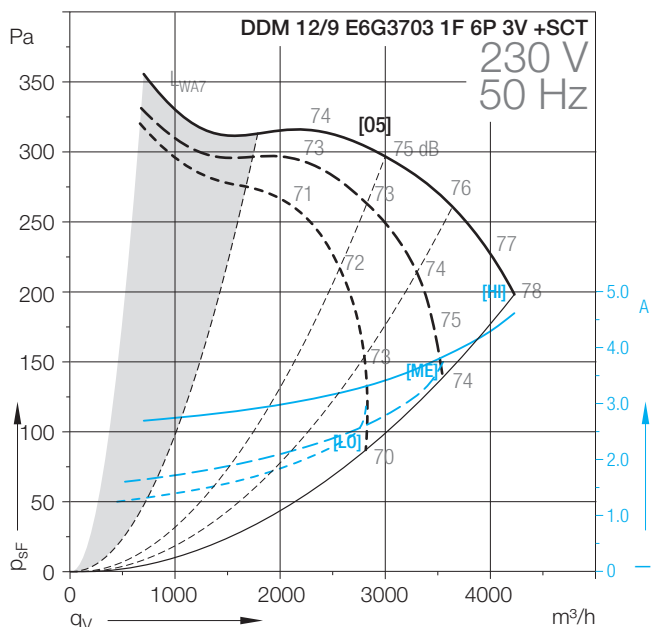
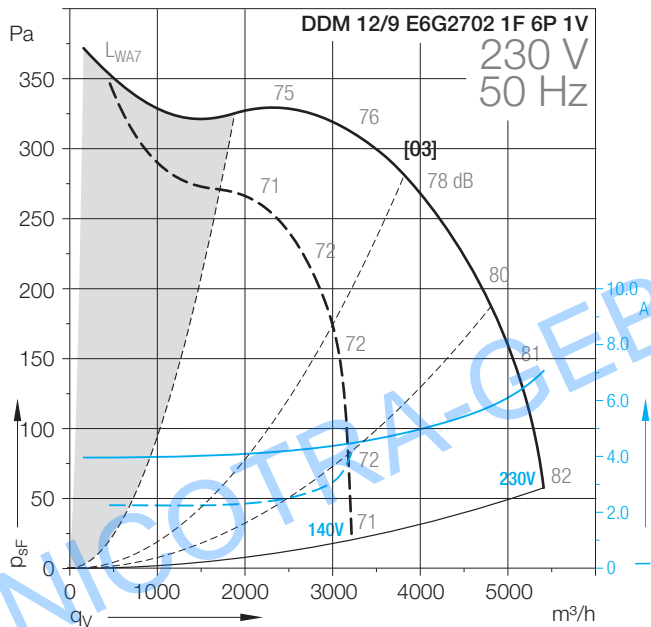
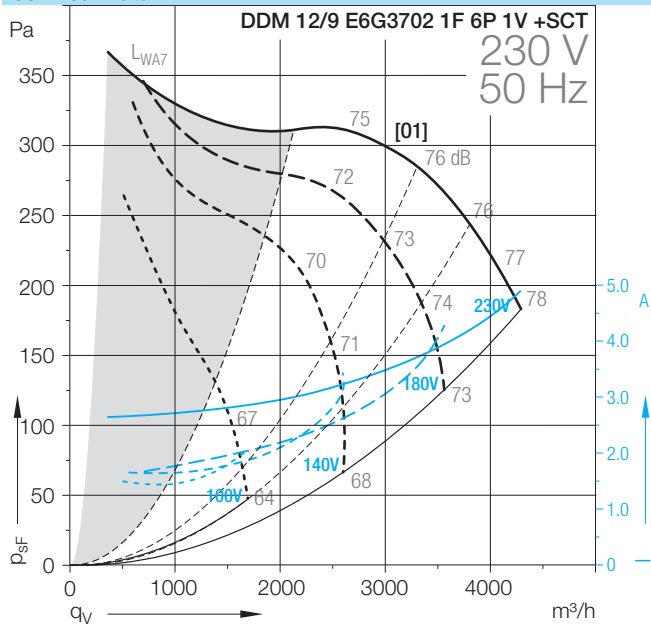

DDM-12/9

Technical Data

	Speed control	Curves	Nominal motor power	Poles	Phases	Connection	Mains frequency	Max. power consumption	Max. current consumption	Speed
DDM 12/9			W	-			Hz	W	A	1/min
E6G3702 1F 6P 1V +SCT	(2)	[01]	515	6	1~		50	1072	5	830
E6G2702 1F 6P 1V	(2)	[03]	590	6	1~		50	1578	6.9	860
E6G3703 1F 6P 3V +SCT	*	[05]	500	6	1~		50	1020	4.5	860

Technical Data

	Operating Capacitor	Nominal capacitor voltage	Motor protection class	Motor thermal class	Thermal protection	Media Temperature max.	Fan weight	Density of media	Installation type (ISO 5801)	Article number
DDM 12/9	µF	V				°C	kg	kg/m³		
E6G3702 1F 6P 1V +SCT	20	450	IP55	F	EXT	40	26	1.2	B	6102N0
E6G2702 1F 6P 1V	25	500	IP10	F	EXT	40	34	1.2	B	6102CL
E6G3703 1F 6P 3V +SCT	20	450	IP55	F	EXT	40	34	1.2	B	6102CA

(1) = Speed controllable via Transformer

(2) = Speed controllable via TRIAC or Transformer

(3) = Speed controllable via Inverter

* = No speed control available

[H] High speed, [ME] Medium speed, [LO] Low speed

Attention! We suggest to do not use the fan in the grey marked area! The noise ratings given in the performance curves are sound power level L_{WA7} , see „Technical Description“.

Dimensions in mm, subject to change.

DDM 12/9 E6G3702 1F 6P 1V +SCT

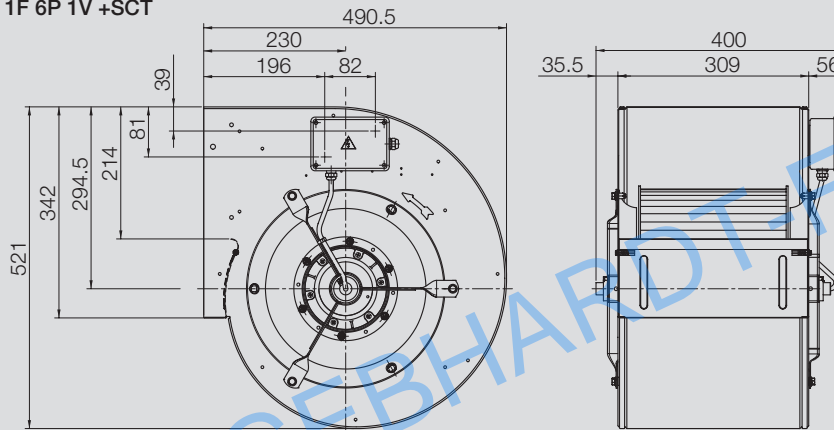

DDM 12/9 E6G2702 1F 6P 1V

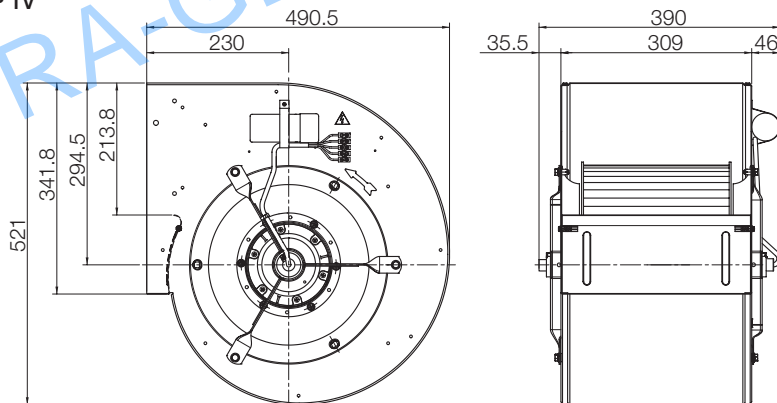

DDM 12/9 E6G3703 1F 6P 3V +SCT

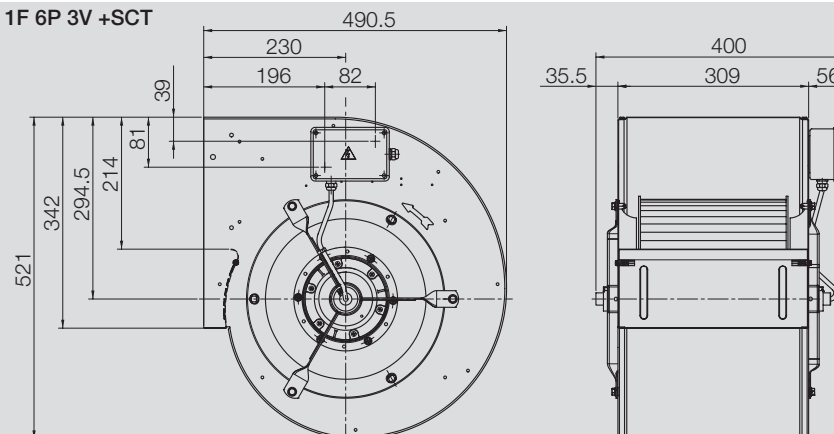

DDM-12/9

Technical Data

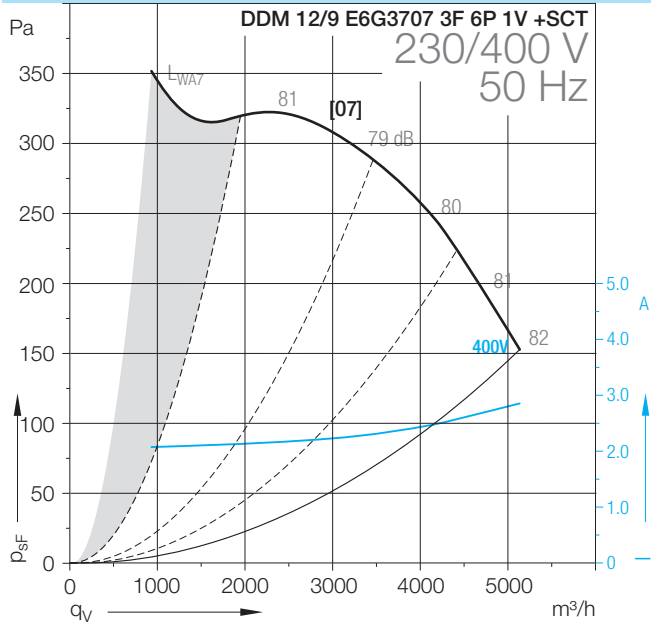

NICOTRA-GEBHARDT-FAN.RU

DDM-12/9

Technical Data										
	Speed control	Curves	Nominal motor power	Poles	Phases	Connection	Mains frequency	Max. power consumption	Max. current consumption	Speed
			W	-			Hz	W	A	1/min
DDM 12/9										
E6G3707 3F 6P 1V +SCT	*	[07]	550	6	3~	Δ/Y	50	1332	2.8	890

Technical Data										
	Operating Capacitor	Nominal capacitor voltage	Motor protection class	Motor thermal class	Thermal protection	Media Temperature max.	Fan weight	Density of media	Installation type (ISO 5801)	Article number
						°C	kg	kg/m ³		
DDM 12/9										
E6G3707 3F 6P 1V +SCT			IP55	F	EXT	40	34	1.2	B	61021R

(1) = Speed controllable via Transformer

(2) = Speed controllable via TRIAC or Transformer

(3) = Speed controllable via Inverter

* = No speed control available

[HI] High speed, [ME] Medium speed, [LO] Low speed

Attention! We suggest to do not use the fan in the grey marked area! The noise ratings given in the performance curves are sound power level L_{WA7} , see „Technical Description“.

Dimensions in mm, subject to change.

DDM 12/9 E6G3707 3F 6P 1V +SCT

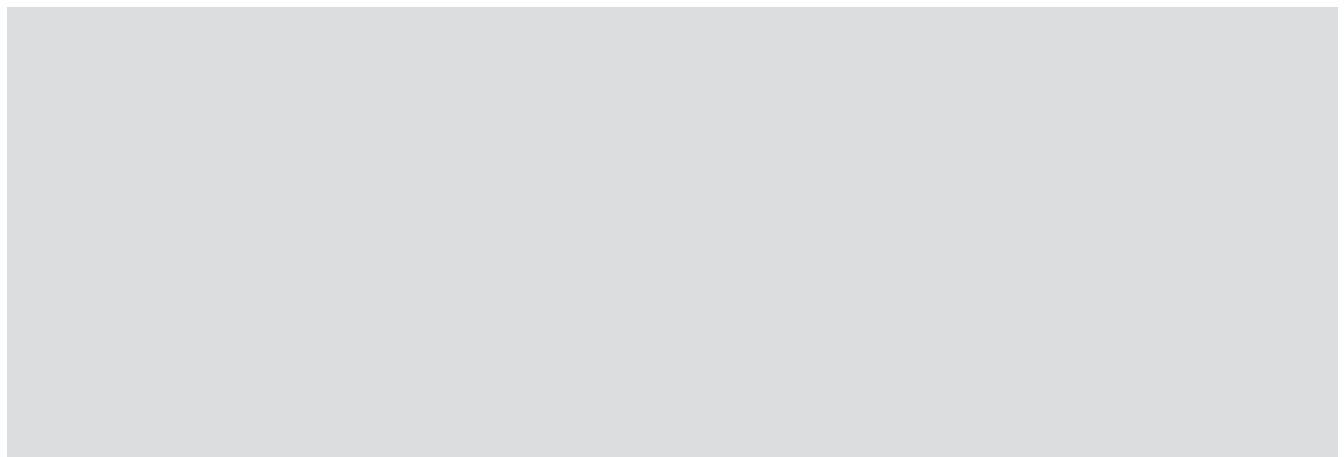
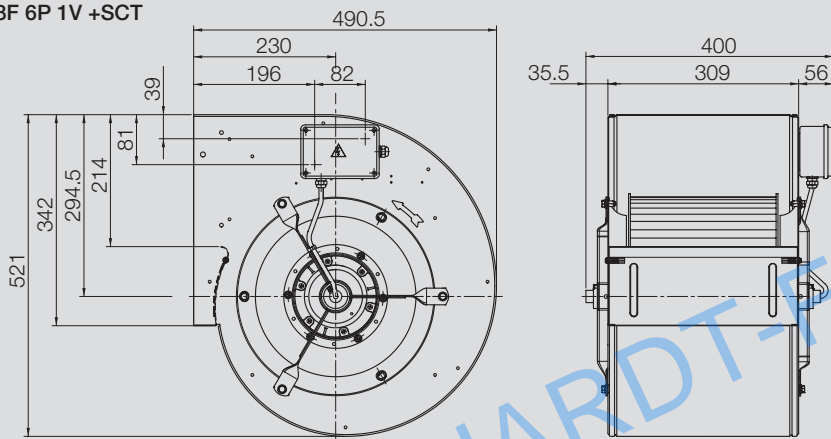

DDM-12/12

Technical Data

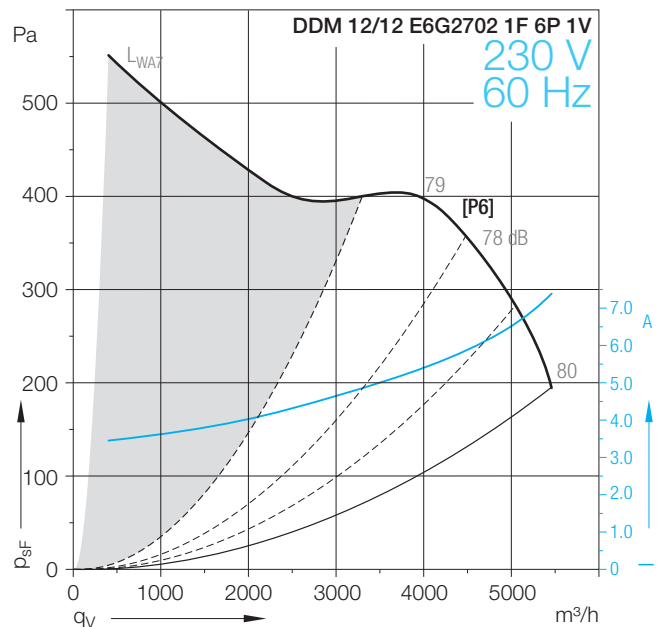
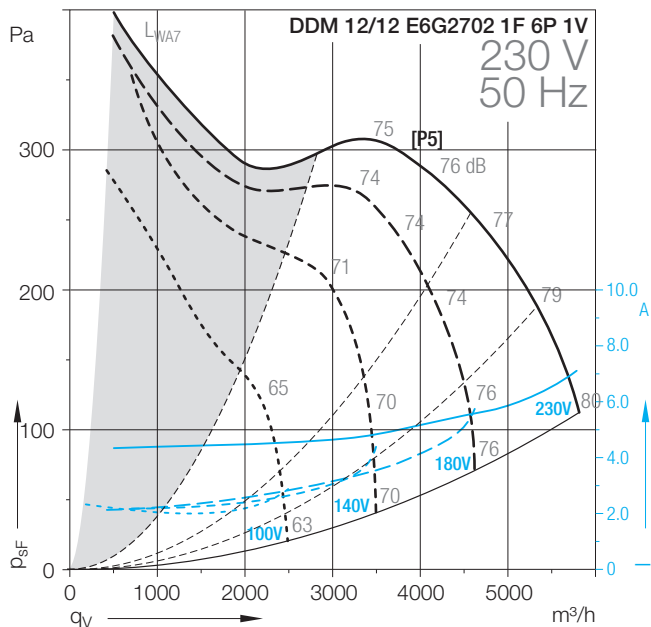
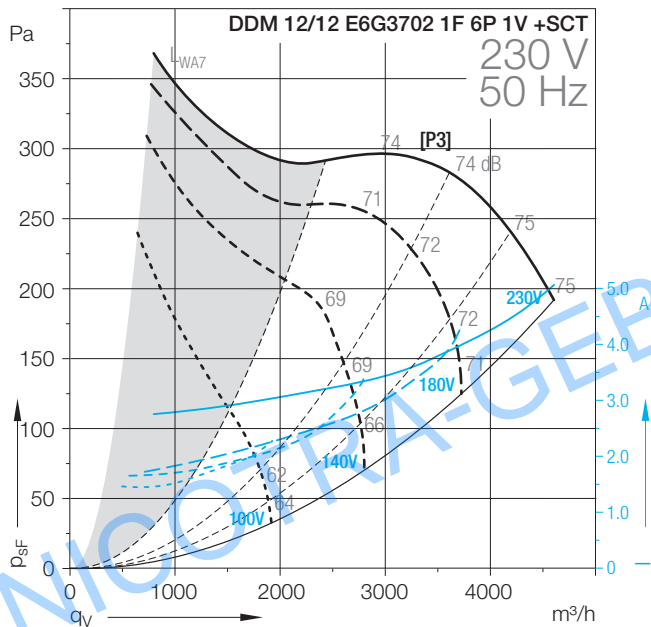
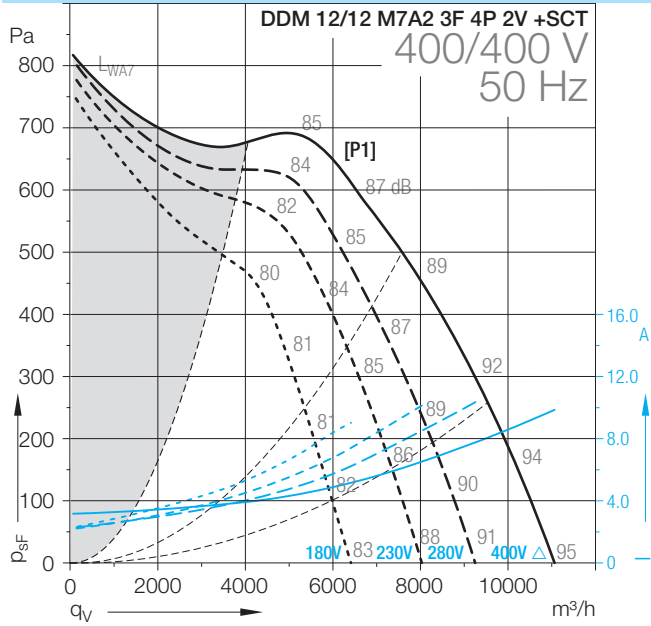

DDM-12/12

Technical Data										
	Speed control	Curves	Nominal motor power	Poles	Phases	Connection	Mains frequency	Max. power consumption	Max. current consumption	Speed
DDM 12/12			W	-			Hz	W	A	1/min
M7A2 3F 4P 2V +SCT	(2)/(3)	[P1]	2200	4	3~	Δ/Y	50	5780	9.7	1400
E6G3702 1F 6P 1V +SCT	(2)	[P3]	515	6	1~		50	1105	5	830
E6G2702 1F 6P 1V	(2)	[P5/P6]	590	6	1~		50/60	1560	6.9	860

Technical Data										
	Operating Capacitor	Nominal capacitor voltage	Motor protection class	Motor thermal class	Thermal protection	Media Temperature max.	Fan weight	Density of media	Installation type (ISO 5801)	Article number
DDM 12/12	μF	V				°C	kg	kg/m³		
M7A2 3F 4P 2V +SCT			IP54	F	EXT	40	59	1.2	B	6M02123
E6G3702 1F 6P 1V +SCT	20	450	IP55	F	EXT	40	36	1.2	B	6102N5
E6G2702 1F 6P 1V	25	450	IP10	F	EXT	40	36	1.2	B	6102AA

- (1) = Speed controllable via Transformer
- (2) = Speed controllable via TRIAC or Transformer
- (3) = Speed controllable via Inverter
- * = No speed control available

[HI] High speed, [ME] Medium speed, [LO] Low speed
Attention! We suggest to do not use the fan in the grey marked area! The noise ratings given in the performance curves are sound power level L_{WA7} , see „Technical Description“.

Dimensions in mm, subject to change.

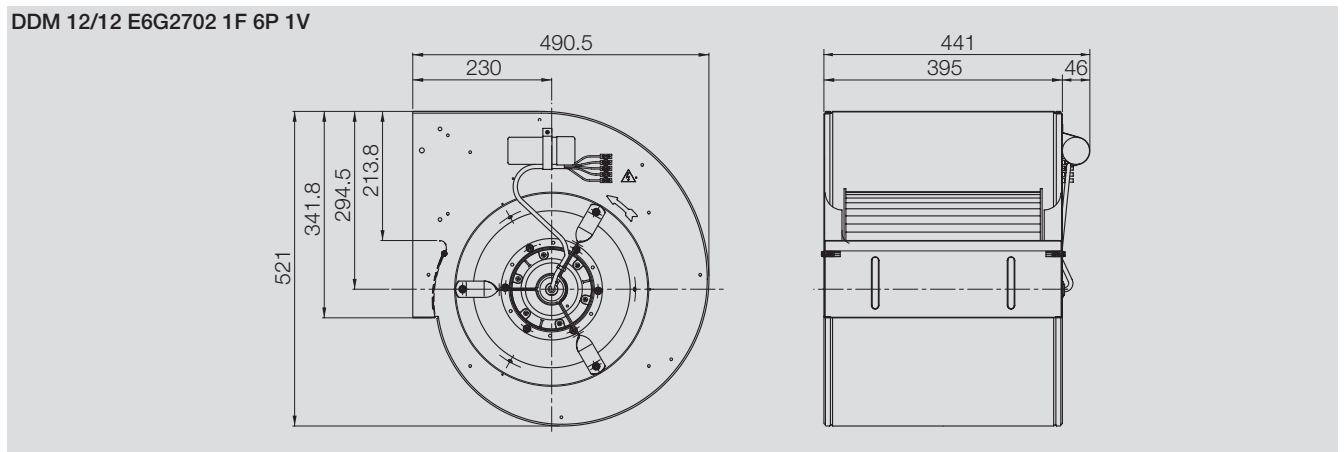
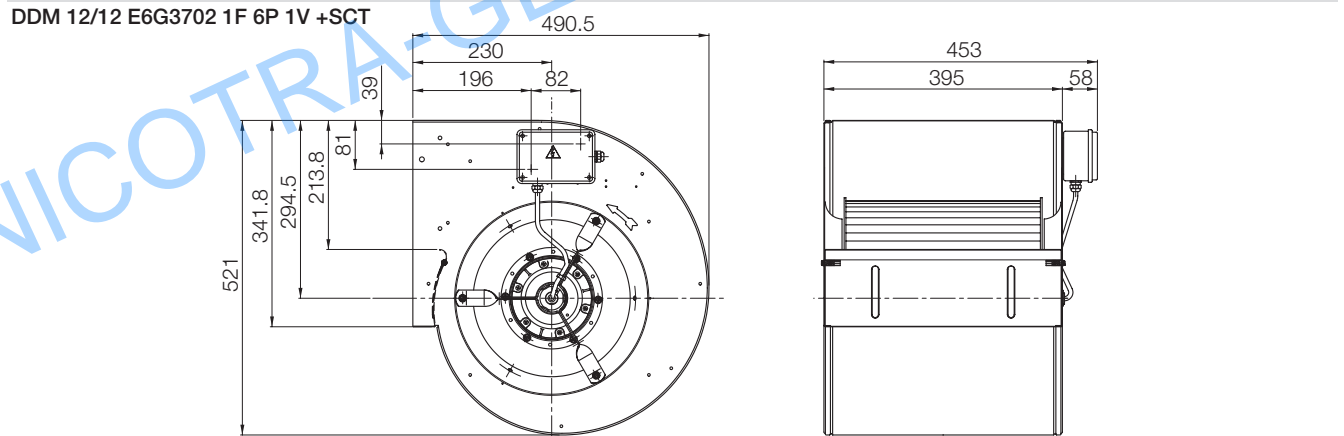
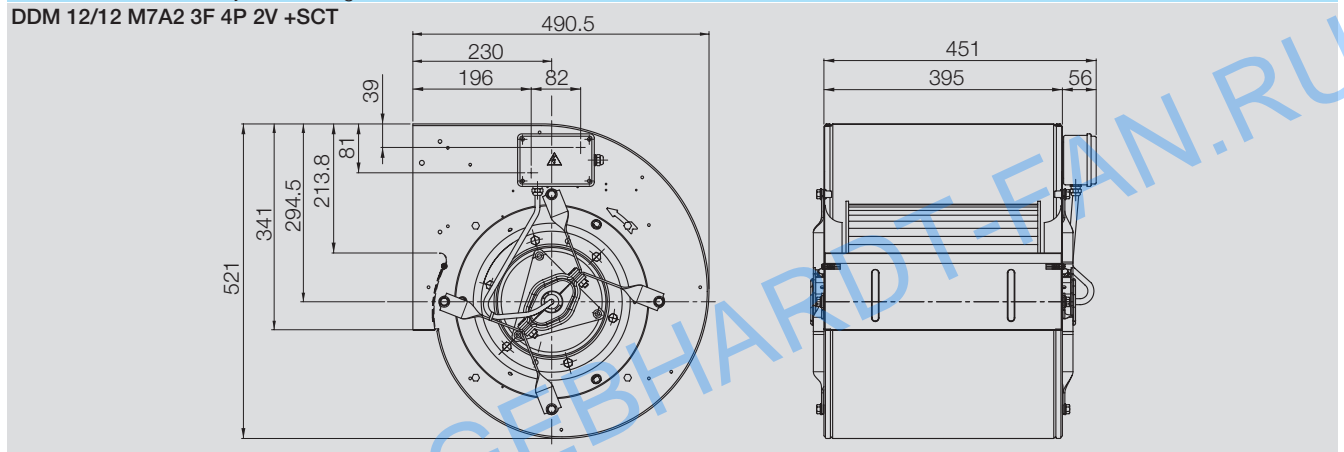

DDM-12/12

Technical Data

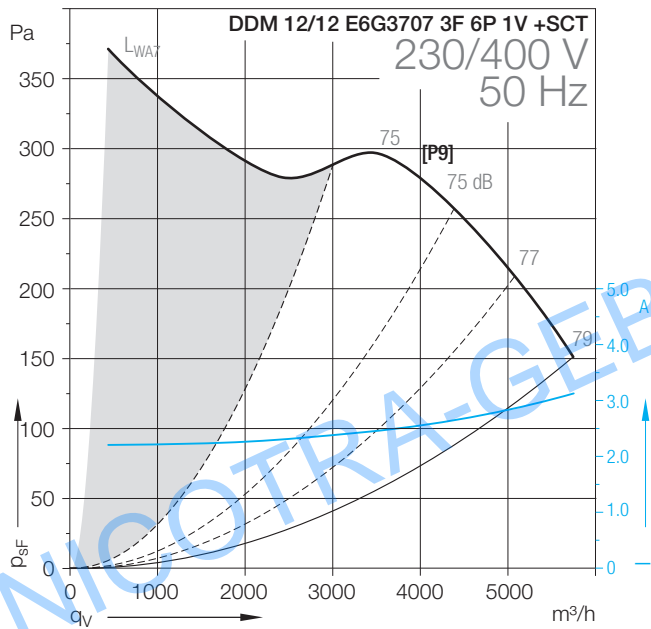
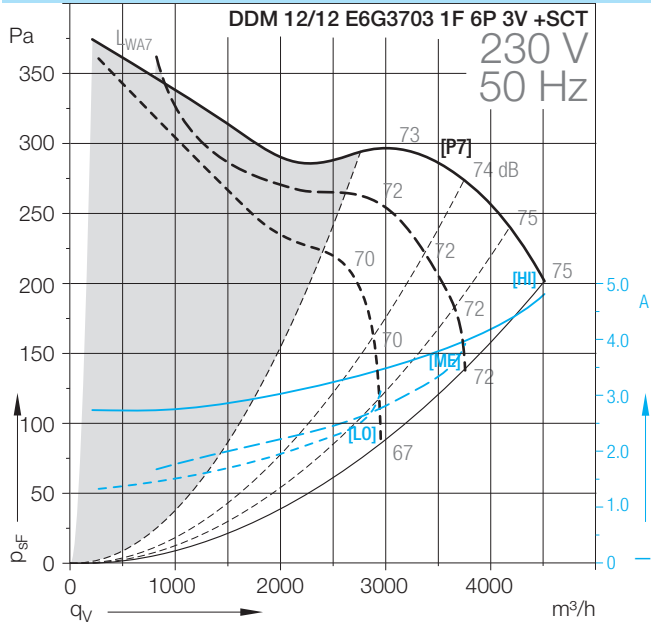

DDM-12/12

Technical Data										
	Speed control	Curves	Nominal motor power	Poles	Phases	Connection	Mains frequency	Max. power consumption	Max. current consumption	Speed
DDM 12/12			W	-			Hz	W	A	1/min
E6G3703 1F 6P 3V +SCT	*	[P7]	500	6	1~		50	1039	4.5	860
E6G3707 3F 6P 1V +SCT	*	[P9]	550	6	3~	Δ/Y	50	1437	2.8	890

Technical Data										
DDM 12/12	Operating Capacitor	Nominal capacitor voltage	Motor protection class	Motor thermal class	Thermal protection	Media Temperature max.	Fan weight	Density of media	Installation type (ISO 5801)	Article number
	μF	V				°C	kg	kg/m ³		
E6G3703 1F 6P 3V +SCT	20	450	IP55	F	EXT	40	32	1.2	B	6102K2
E6G3707 3F 6P 1V +SCT			IP55	F	EXT	40	34	1.2	B	6102OR

(1) = Speed controllable via Transformer

(2) = Speed controllable via TRIAC or Transformer

(3) = Speed controllable via Inverter

* = No speed control available

[HI] High speed, [ME] Medium speed, [LO] Low speed

Attention! We suggest to do not use the fan in the grey marked area! The noise ratings given in the performance curves are sound power level L_{WA7} , see „Technical Description“.

Dimensions in mm, subject to change.

DDM 12/12 E6G3703 1F 6P 3V +SCT

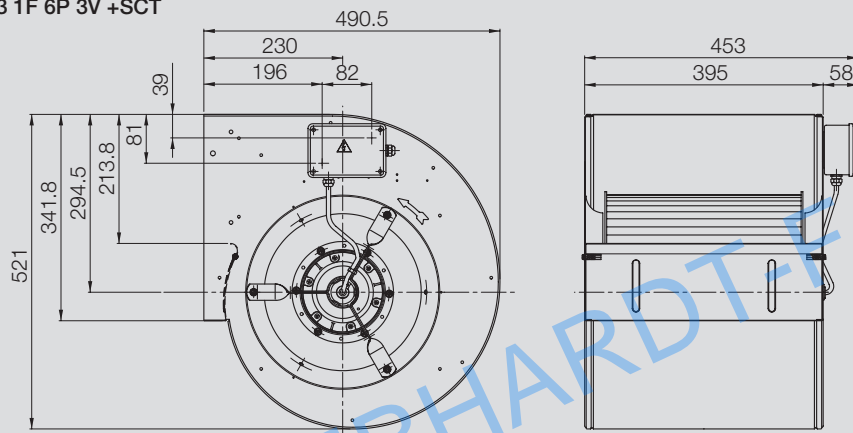

DDM 12/12 E6G3707 3F 6P 1V +SCT

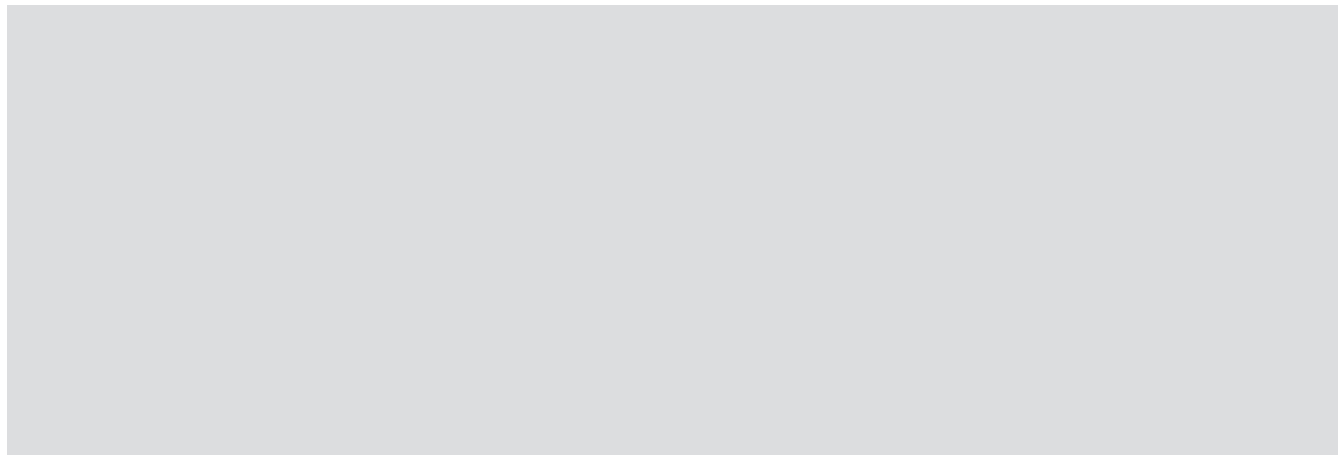
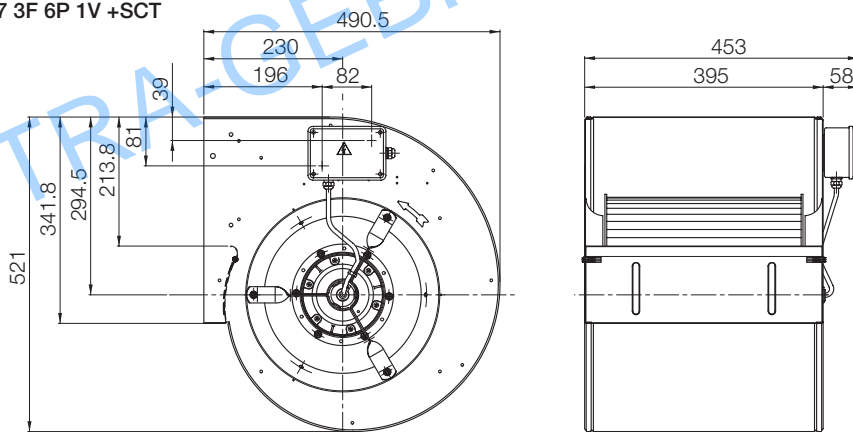

DDM

Specifications



High performance centrifugal fan DDM

Double width, double inlet (DWDI), direct driven forward curved blades fan. Lap-jointed scroll of galvanized steel (EN 10142) assembled through a high technology roller-lock seaming for fan sizes 7 inches and larger, spot-welded scroll of Sendzimir galvanized steel for smaller sizes. Straight cut off plate at fan outlet. Impeller with forward curved blades of galvanized steel, directly mounted on an "External Rotor" motor for optimal motor cooling and no transmission losses. Motors may be single or three-phase, single or multiple speed, speed-adjustable by voltage regulation through transformers or TRIAC regulators. Motors suitable for use at 50Hz or 60Hz are available. Built-in thermal protection devices *either in series or wired out* is standard fit. Maintenance free self-aligning ball bearings, vibration isolation pads. Impeller dynamically balanced in class 6.3, according to ISO 1940. Different fan options and accessories, motor types and sizes available - see technical data.

Fan data

Fan type		
Volume flow	Q_V		m ³ /h
Static pressure	p_{sF}		Pa
Air density at fan inlet	ρ_1		kg/m ³
Air temperature	t		°C
Max. power consumption	P_e		kW
Speed	N		1/min
Frequency	f		Hz
Sound power level (A weighted)	L_{WA}		dB
Weight	m		kg

Fittings / Accessories

- Outlet flange - O
- Outlet flexible connection - A (sizes $\geq 7/7$)
- Mounting feet - O/A (sizes $\geq 7/7$)
- Terminal box - O
- Inlet guard - O/A
- Outlet guard - O/A
- Powder-coating - O
- TRIAC electronic regulators - A

Legend

O = Options
 A = Accessory
 O/A = The item could be delivered as an option or an accessory

Please, check availability of each individual option or accessory on each specific fan model.

Fittings / Accessories

Accessories

All options and accessories must be specified separately. Please take the technical data and dimensions from the corresponding page of the catalogue.

Flanges



Made from galvanized or painted steel, to connect ducts and system components to the fan outlet side.

Dimensions in mm, subject to change.

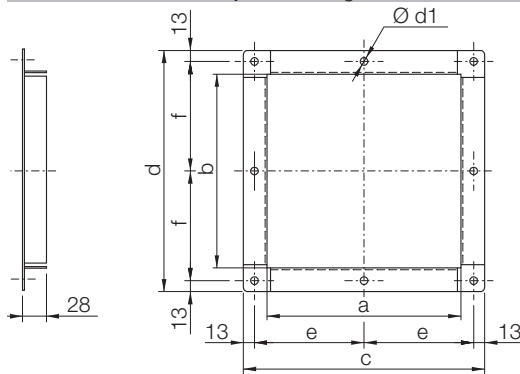

DDM	a	b	c	d	e	f	Ø d1
7/7	232	201	288	257	131	115.5	9
7/9	298	208	354	257	164	115.5	9
9/7	232	255	288	311	131	142.5	9
9/7 TIGHT	232	263	288	311	131	142.5	9
9/9	298	255	354	311	164	142.5	9
9/9 TIGHT	298	263	354	311	164	142.5	9
10/8	265	284	321	340	147.5	157	9
10/10	331	284	387	340	180.5	157	9
12/9	309	334	365	390	169.5	182	9
12/12	395	334	451	390	212.5	182	9
15/15	471	397	527	453	250.5	213.5	9

Flexible connection

Dimensions in mm, subject to change.

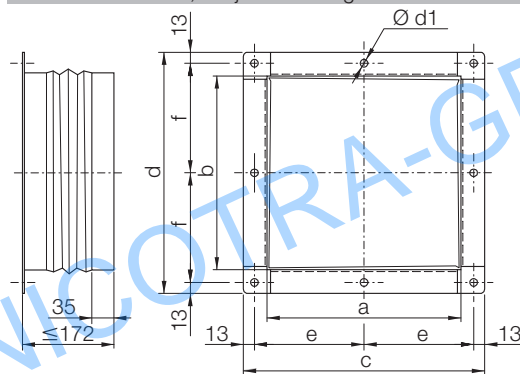

DDM	a	b	c	d	e	f	Ø d1
7/7	232	201	288	257	131	115.5	9
7/9	298	208	354	257	164	115.5	9
9/7	232	255	288	311	131	142.5	9
9/7 TIGHT	232	263	288	311	131	142.5	9
9/9	298	255	354	311	164	142.5	9
9/9 TIGHT	298	263	354	311	164	142.5	9
10/8	265	284	321	340	147.5	157	9
10/10	331	284	387	340	180.5	157	9
12/9	309	334	365	390	169.5	182	9
12/12	395	334	451	390	212.5	182	9
15/15	471	397	527	453	250.5	213.5	9

Dimensions in mm, subject to change.

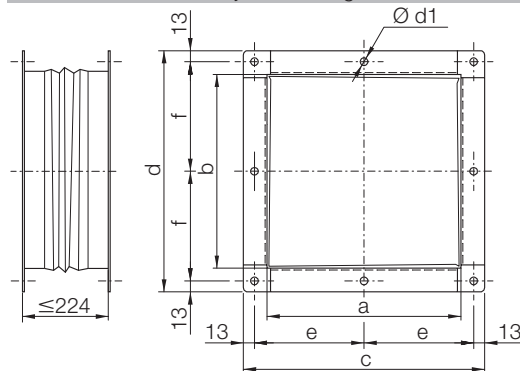

DDM	a	b	c	d	e	f	Ø d1
7/7	232	201	288	257	131	115.5	9
7/9	298	208	354	257	164	115.5	9
9/7	232	255	288	311	131	142.5	9
9/7 TIGHT	232	263	288	311	131	142.5	9
9/9	298	255	354	311	164	142.5	9
9/9 TIGHT	298	263	354	311	164	142.5	9
10/8	265	284	321	340	147.5	157	9
10/10	331	284	387	340	180.5	157	9
12/9	309	334	365	390	169.5	182	9
12/12	395	334	451	390	212.5	182	9
15/15	471	397	527	453	250.5	213.5	9

Fittings / Accessories

Mounting feet

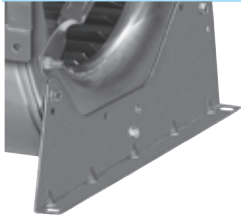

Feet made from galvanized steel, either mounted or loose, enable the fan to be installed with a 0, 90 and 270 orientation.

Dimensions in mm, subject to change.

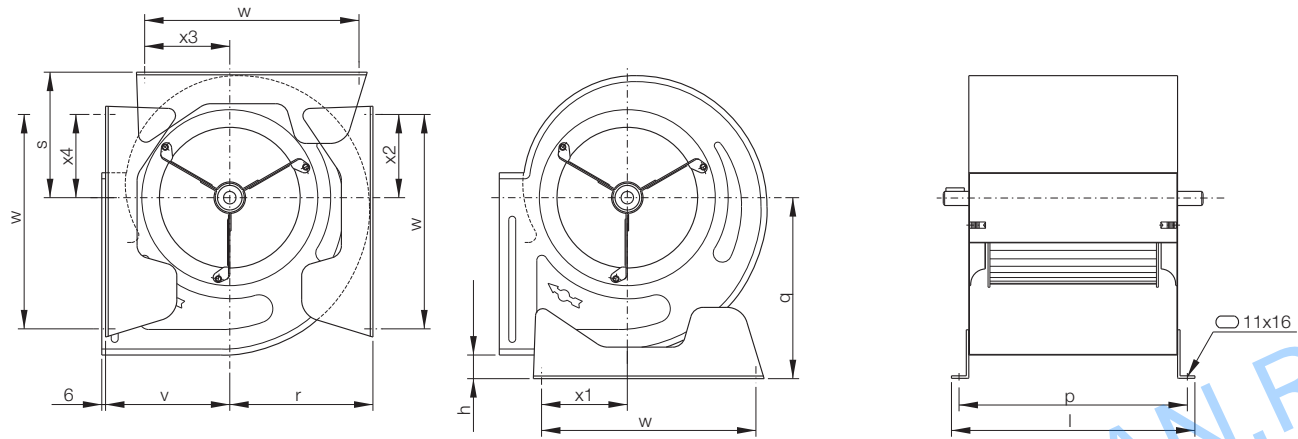

DDM	h	l	p	q	r	s	v	w	x1	x2	x3	x4
7/7	17	282	258	203	169	145	147	225	117	86	88	47
7/9	17	348	324	203	169	177	179	300	119	124	123	120
9/7	38	282	258	253	199	177	179	300	119	124	123	120
9/7 TIGHT	17	282	258	202	170	149	-	225	120	86	97	-
9/9	38	348	324	253	199	177	179	300	119	124	123	120
9/9 TIGHT	17	348	324	202	170	149	-	225	120	86	97	-
10/8	38	315	291	287	227	198	197	340	136	132	135	132
10/10	38	381	357	287	227	198	197	340	136	132	135	132
12/9	38	359	335	332	266	232	224	408	161	153	161	153
12/12	38	445	421	332	266	232	224	408	161	153	161	153
15/15	38	521	497	380	309	272	258	495	197	211	201	200

Terminal box



Each fan is equipped with a loose cable, a terminal strip or a terminal box (see specific catalog data for details)

The terminal box is commonly fitted to the side plate of the fan. It is made of plastic material and provided with cable glands. A schematic diagram, always provided with the fan, displays the proper electrical connection.

Dimensions in mm, subject to change.

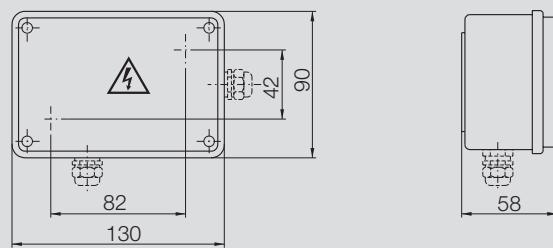

Protection guards



Inlet or outlet protection guards are available as accessories from size 7/7 to 10/10, for bigger sizes and for further information, please contact Nicotra Gebhardt technical department.

Fittings / Accessories

Increased corrosion protection

Nicotra Gebhardt fans are provided – as a standard equipment – with a highly efficient corrosion protection but, in the event of extremely high corrosion risk, additional corrosion protections might be required. Following to the application and corrosion stress conditions, special coatings of various types and thickness can be supplied on request.

RVM - Single-phase manual regulator



Electronical speed control unit producing a stepless modulated output voltage for fans with speed controlled single phase motors

Execution

Casing made of impact resistant plastic.

Function

The speed controller is equipped with an EMC-filter, a turning knob for speed control starting at a fixed rpm-value, an operation indicating light (RVM 5I, RVM 9I, RVM 20I), and an internal fuse protection.

Technical Data

	Article number	Nominal voltage V	Max. current A	Frequency Hz	Protection class	Temperature range °C	Fuse	a mm	b mm	c mm
RVM 1,5E	K43157	230	1.5	50/60	IP20	+0/+40	5X20 10A FAST	82	82	38
RVM 3E	K43142	230	3	50/60	IP20	+0/+40	5X20 10A FAST	82	82	38
RVM 5I	K43143	230	5	50/60	IP54	-10/+40	5X20 10A FAST	125	125	90
RVM 9I	K43144	230	9	50/60	IP54	-10/+40	6,3X32 20A FAST	125	125	105
RVM 20I	K43139	230	20	50/60	IP54	-10/+40	6,3x32 32A GL	175	175	105

Dimensions

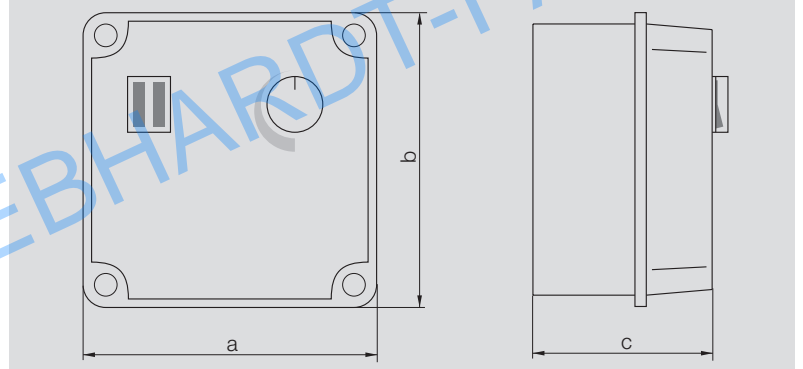

Wiring Diagram

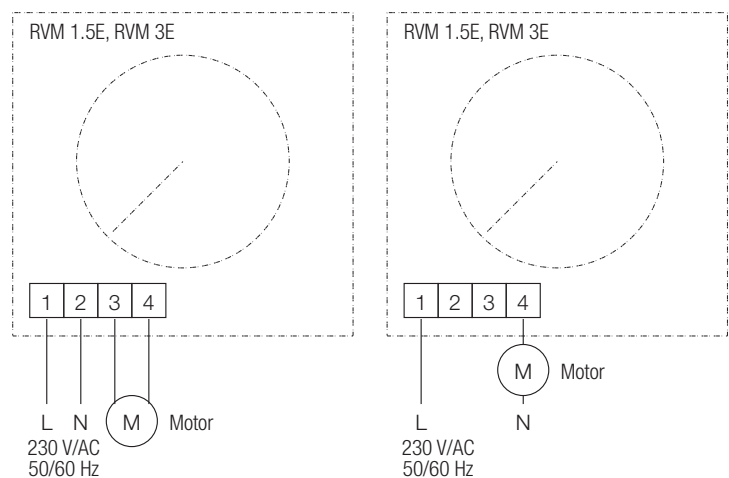

Fittings / Accessories

Wiring Diagram

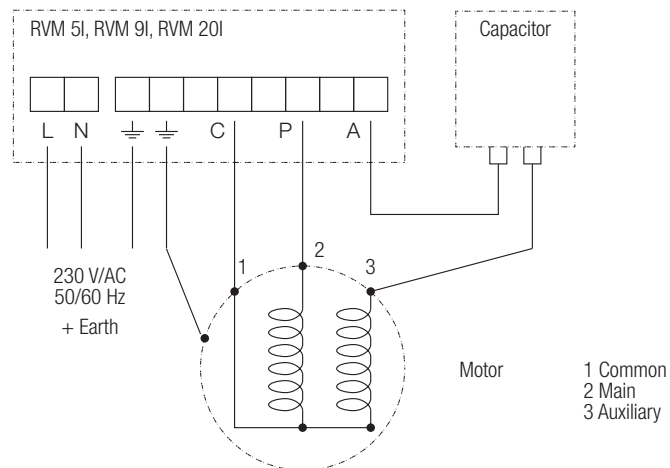

RVT - Three-phase manual regulator



Electronical speed control unit producing a stepless modulated output voltage for fans with speed controlled three phase motors.

Execution

Plastic casing with cast aluminium base plate, IP54 protection class.

Function

With the control unit a setting of the minimum speed value as well as the maximum speed is provided. It is equipped with an internal overload protection and, as an option, there are contacts provided for connecting the thermo contacts (PTO) in the motor winding.

Following to switching the unit on, the controller automatically is operating a softstart of the motor up to the speed which is set by the position of the potentiometer. By turning the potentiometer the motor speed will be changing due to driving it with a varying voltage through phase cutting.

Technical Data

	Article number	Nominal voltage V	Nominal current A	Frequency Hz	Protection class	Temperature range °C	Fuse	a mm	b mm	c mm
RVT 3A	K43114	400	3	50/60	IP54	+0/+40	6x32 GF10	175	175	105
RVT 6A	K43115	400	6	50/60	IP54	+0/+40	6x32 GF20	175	175	105
RVT 9A	K43116	400	9	50/60	IP54	+0/+40	6x32 GF20	175	250	105

Dimensions

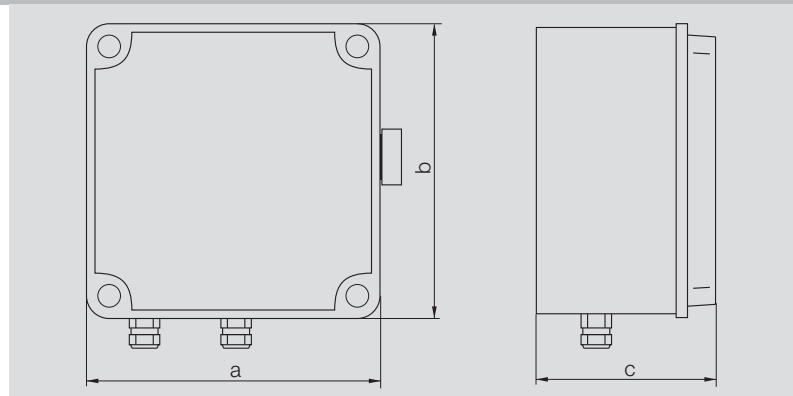

Fittings / Accessories

Wiring Diagram

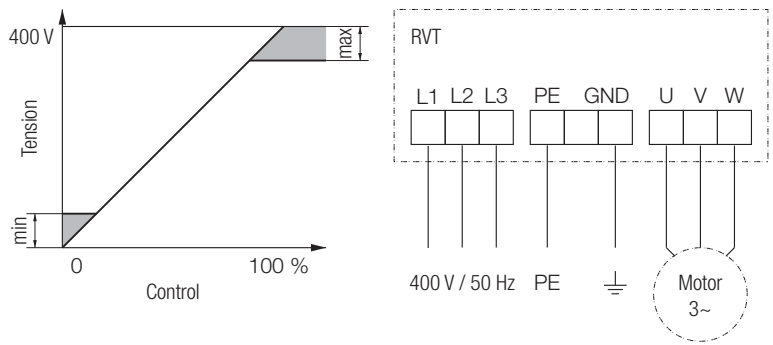

Star-delta switch



Enclosed selector for star-delta motor configuration for three-phase motors.

Execution

Insulated polycarbonate module, IP66 protection degree. front mounting, silver front panel, 60 switching angle, terminals accessible both from mounting direction or laterally, data rated according to IEC 60947.

Function

A 3-position changeover switch for 0 = Motor OFF, Y = STAR motor configuration, Δ = DELTA motor configuration. It must be installed between the 3-phase power supply (L1, L2, L3) and a 3-phase controllable motors, having the STAR-DELTA terminals externally available (U1, V1, W1 and U2, V2, W2 respectively). It provides a safe way to switch between the STAR and DELTA motor configurations, changing, in this way, between the high (DELTA) and low (STAR) motor speed.

The switch can't be used as STAR/DELTA motor starter!

Technical Data

Article number	Nominal voltage V	Nominal current A	Frequency Hz	Protection class	Temperature range °C	
M200	K43131	400	16	50/60	IP66	-25/+40

Dimensions in mm, subject to change.

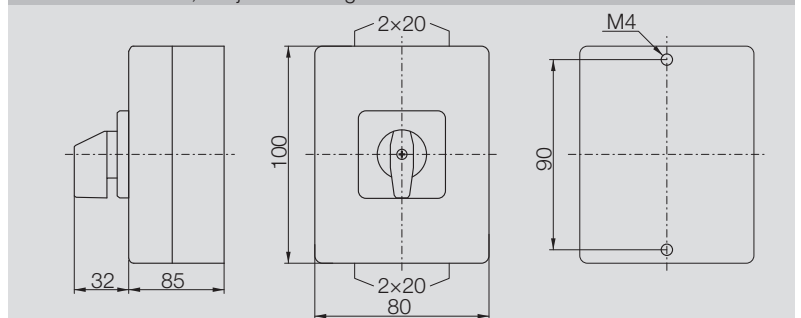

Wiring Diagram

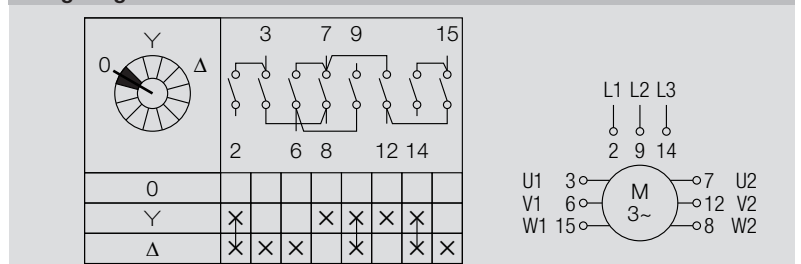

Description

Safety

These fans are intended to be incorporated into finished products for the treatment of clean and filtered air, free of dust, particles, shavings, grease, etc., within the rated ranges of temperature and electrical supply.

The design of the installation shall guarantee the essential safety requirements, as specified by the locally enforceable legislation, including safety against human contact with moving parts, e.g. by application of the design principles stated in EN ISO 12100.

When the inlet and/or outlet of a fan are connected to a ducting system, or to a closed plenum, including integral filters or grids, these may be designed also to provide the specified protection level.

Otherwise, the fan must be protected by fitting appropriate inlet or outlet guards, designed in accordance with EN ISO 13857, available from Nicotra Gebhardt as accessories or options.

Type code

	2P 4P 6P	1V 2V 3V 4V	FL	SCT	SP	SB	GRG	GRGP
1F 3F								
Single phase Three phase	2-pole 4-pole 6-pole	1-Speed 2-Speeds 3-Speeds 4-Speeds	Outlet flange	Terminal box	Special version	Mounting Feet	Inlet guard	Outlet guard

Performance data

Air performance ratings shown in this catalogue have been derived from performance tests made with installation type "B", with free inlet and ducted outlet.

The performance data shall be obtained in a laboratory registered by AMCA for AMCA 210/99 air performance testing. Data are not certified by AMCA.

Ratings are referred to the standard air density of $\rho_1 = 1.2\text{kg/m}^3$ at the fan inlet.

Sound

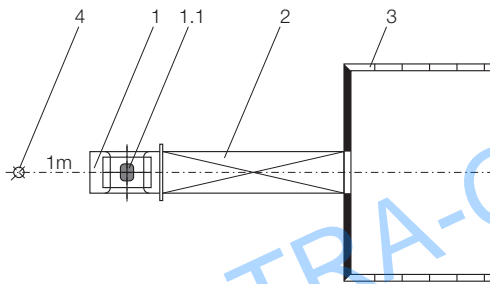

In the diagrams, the A-weighted housing and free inlet sound power level L_{WA7} is given as the emission parameter for the ventilator.

The A-weighted noise level L_{pA7} for a distance of 1m (see sketch) is achieved approximately in that the correction value given below is subtracted from the respective A sound power level.

It should be noted that site acoustics, duct design, reverberation, natural frequencies etc. can all influence noise to a greater or a lesser extent.

$$L_{pA7} \approx L_{WA7} - dL$$

Correction values dL :

Size $\leq 10/10$: $dL = 11\text{dB}$

Size $\geq 12/9$: $dL = 13\text{dB}$

- 1 = Fan
- 1.1 = Motor
- 2 = duct on discharge
- 3 = Chamber
- 4 = Microphone position

Fan operating area

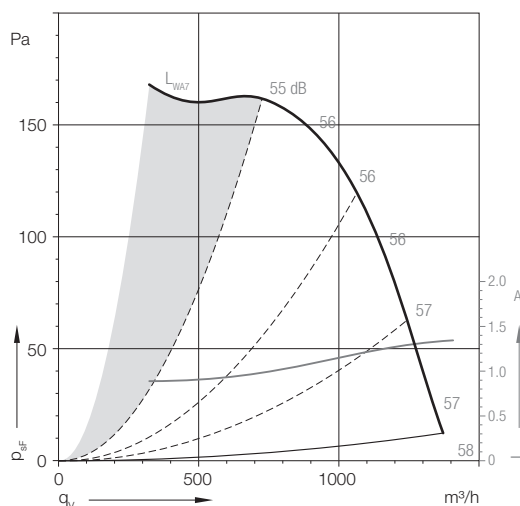

For a proper fan selection the duty point in the grey area to the left of the leftmost dashed parabolic line drawn on each performance diagram should preferably be avoided. In this area the fan stall is producing fluctuating pressure and fluctuating loads on the fan and motor; some single-phase motors may also be overheating in this low-load condition.

When the performance curves of a fan are cut to the right with continuous-line parabola, a fan selection with the duty point located below of this parabola shall be carefully avoided, because the drive motor would be overloaded and would be overheating. Such an operating condition may be evidenced by a motor input current exceeding the maximum rated value.

Description

Fan lifespan

The high level of manufacturing technology and the use of selected materials provide a considerable fan operating lifetime.
In most applications, the fan components more subjected to wear are the motor bearings.
The bearings are sized to reach, using 80% of the maximum allowed current and working at an air temperature not higher than 40°C, a L_{10h} operating life of 20,000 hours. This means a 7 years fan lifetime, for fans running 8 hours a day.

Media

This range of fans are specially designed for use into air handling units (AHU) and ventilation systems.
The centrifugal fans are ideal for conveying clean air. The allowed air temperature comes from -20°C to +40°C.

Motors

Most motors have "F" ISO insulation class but some of the smaller models have nevertheless "B" ISO insulation class.
Motors could have IP32; IP44; IP54 or IP55 protection class (closed frame) or IP10; IP20 protection class (open frame).
Detailed information for each fan model are provided with fan specification on the product pages.

Motor protection

All standard production motors are equipped with an integrated thermal overload protectors (TOP), as protection against thermal overload.
TOP may be wired internally to windings and then they'll automatically stop the motor, if a overheating event occurs, and start the motor again once it is cooled down.
TOP may alternatively be externally wired, that means TOP terminals are available to the user in the motor terminal block or terminal box.
In this case, the TOP terminals can be manually connected in series between power supply and motor windings or, alternatively, to an external device that switches off the mains to prevent that the motor be damaged by an overheating conditions.

Speed regulation generally

All standard production motors can always be used with transformers or devices which do not modify the sinusoidal wave line to change the fan speed is always allowed.

Speed regulation for fans equipped with single-phase motors

Single or multiple speed available. Single phase motors are generally suitable for speed regulation by changing the input voltage with our electronic single-phase RVM speed regulators (see chapter "Options/Accessories" for further information).
The speed variable types are marked with an dot in the technical data tables.
The reduced – voltage curves shown in the catalogue may be obtained by either using transformers or our RVM regulators. In the last case, we have commonly used a 2-wires connection for running currents up to 3 Ampere max and a 3-wires connection for higher running currents.
Speed regulation of multi-speed fans is obtained by connecting the mains to the correct motor terminals according to the wiring diagram supplied with each fan.

Speed regulation for fans equipped with three-phase motors

Single or double speed available. Performance diagrams of single speed fans usually shows only the curve referred to a 230V star – 400V delta configuration.
Performance diagrams of double speed fans usually shows the curves referred to a 400V star (high speed) – 400V delta (low speed) configurations.
The use of RVT controllers or inverter is only acceptable with special motors equipped with a reinforced insulation of the windings. In this case, these devices shall be in accordance with the requirements of IEC / TS 60034-17:2006.

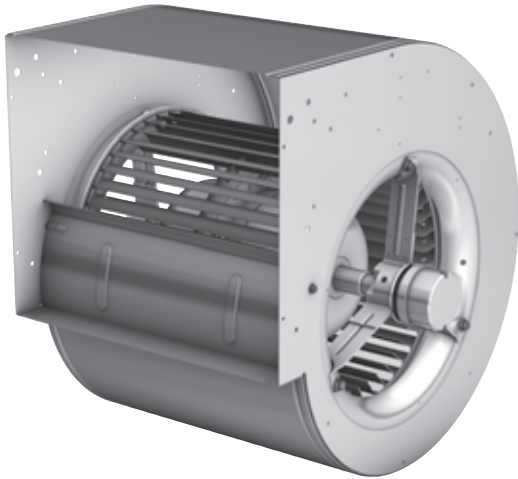

The high efficiency direct driven centrifugal fans DDMB, with brushless DC external rotor motor:

The logical continuation of the successful series DDM.

Product features

- new brushless-DC external rotor motor
- new lapjointed scroll
- high efficiency
- low power consumption
- low sound power level
- high reliability

High efficiency variable speed drive

Energie saving concept

- high efficiency drive due to optimized motor design
- PFC disabled at Stop
- NTC bypassed during operation

General features

- integrated PFC
- brownout protection
- IP54 for complete drive
- dry contact - error signal
- simple usage - fan selection by DIP switches and GO! (no parameter setup)
- designed for double inlet fans
- external unit - no obstruction of intake - less aerodynamic losses

Interface

- analogue
- MODBUS RTU

Comparison of the different levels of system efficiency

Brushless DC motor has a significantly higher level of drive system (motor and control) efficiency under all operating conditions.

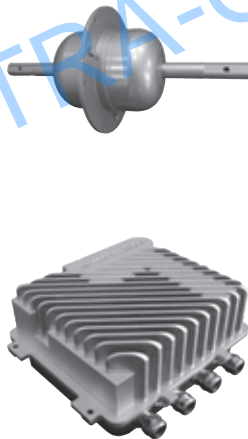
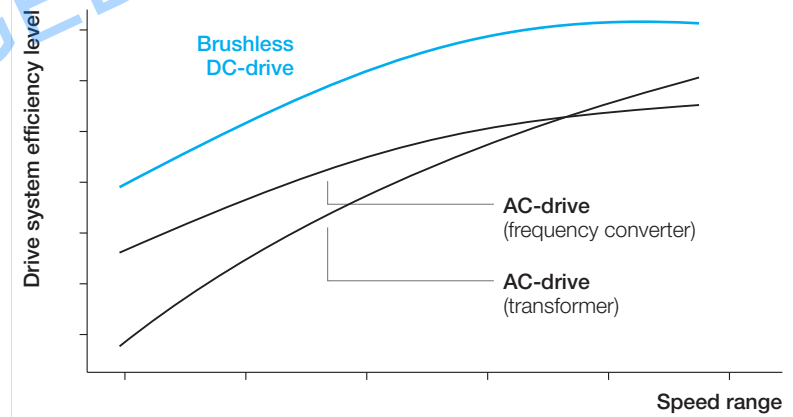

NICOTRA-GEBHARDT-FAN.RU

Program overview:

DDMB range

This kind of fans are specially conceived for use in dust-free environments, at temperatures up to +40°C, or higher on selected models. The performance data have been obtained in a laboratory registered by AMCA for AMCA 210/99 air performance testing. Data are not certified by AMCA.



Fan range DDMB

- Impeller size (width and diameter) up to 12"
- Brushless-DC external rotor motor
- High efficient variable speed drive
- External unit – no obstruction of intake
- Air flow up to 6,000m³/h
- Static pressure up to 1,500Pa

The variety of DDMB

We have the right fan for all your applications!

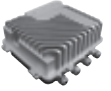
Many different sizes, versions and options are available in the DDMB range!

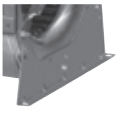
Version	Description	Figure
DDMB	Lap-jointed scroll made from galvanized steel and forward curved blades impeller directly mounted on a brushless-DC external rotor motor .	
EKE 07	external commutation unit	
+FL	with discharge flange mounted	
+SB	with housing feet either mounted or loose	

DDMB-7/7

Technical Data

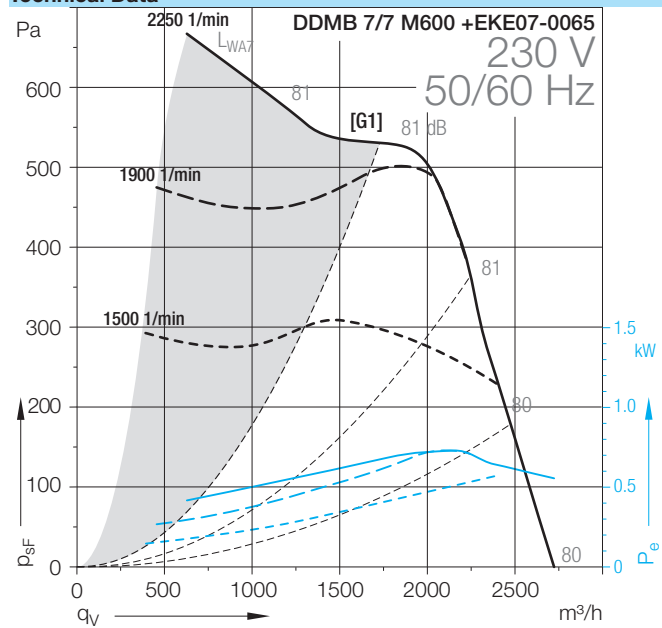

NICOTRA-GEBHARDT-FAN.RU

DDMB-7/7

Technical Data									
	Speed control	Curves	Nominal motor power W	Mains voltage V	Phases	Mains frequency Hz	Max. power consumption W	Max. input current A	Speed 1/min
DDMB 7/7									
M600 +EKE07-0065	(5)	[G1]	310	230	1~	50/60	750	3.2	2250

Technical Data									
	Motor protection class	Motor thermal class	Thermal protection	Media Temperature max. °C	Fan weight kg	Density of media kg/m³	Installation type (ISO 5801)	Article number	
DDMB 7/7									
M600 +EKE07-0065	IP54	F	EXT	40	15	1.2	B	6M0400	

(5) = Stepless speed controllable via electronic Commutation Unit
 The fans must be used with the Electronic Commutation Unit EKE07.

Attention! We suggest to do not use the fan in the grey marked area! The noise ratings given in the performance curves are sound power level L_{WA7} , see „Technical Description“.

Dimensions in mm, subject to change.

DDMB 7/7 M600

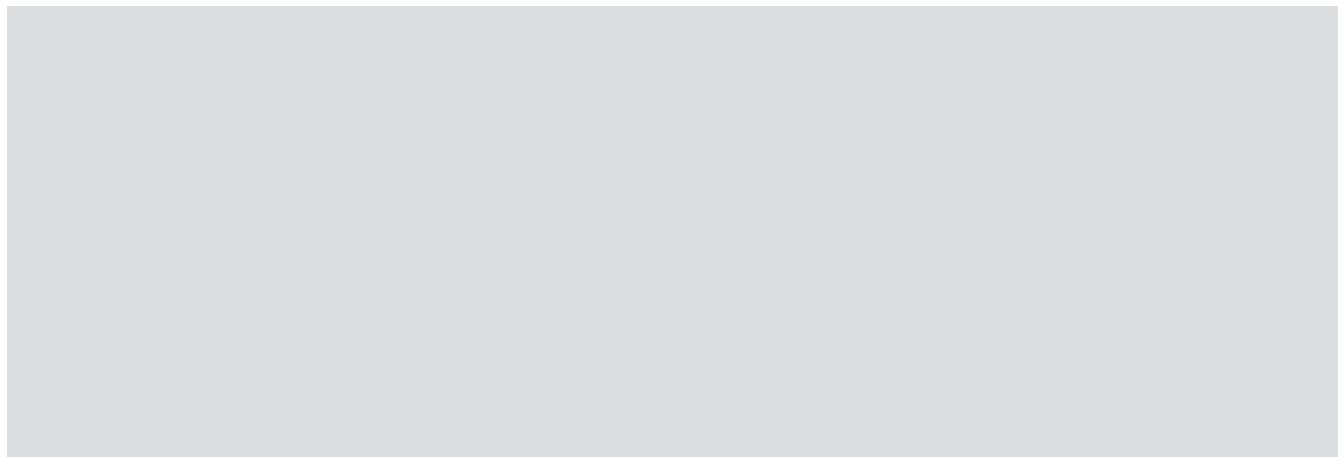
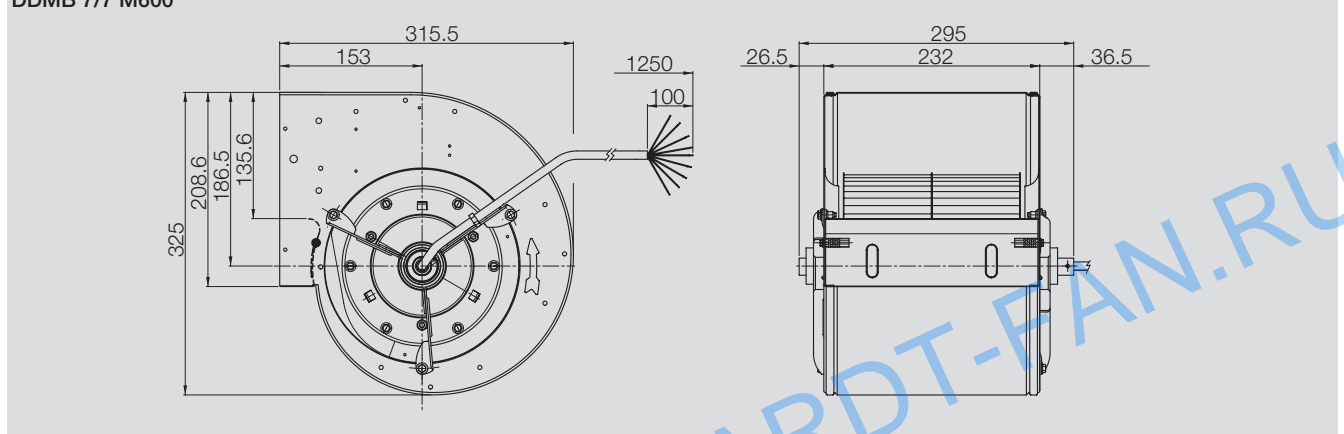

DDMB-9/7

Technical Data

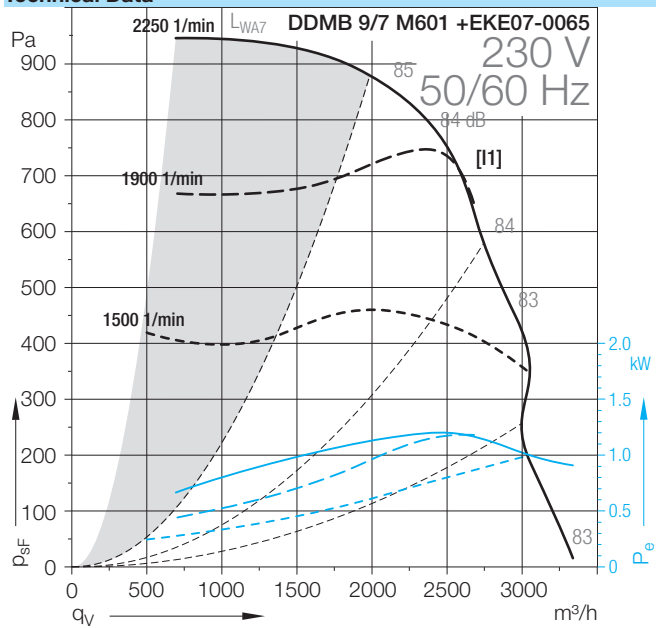

NICOTRA-GEBHARDT-FAN.RU

DDMB-9/7

Technical Data									
	Speed control	Curves	Nominal motor power W	Mains voltage V	Phases	Mains frequency Hz	Max. power consumption W	Max. input current A	Speed 1/min
DDMB 9/7									
M601 +EKE07-0065	(5)	[I1]	560	230	1~	50/60	1200	5.1	2250

Technical Data									
	Motor protection class	Motor thermal class	Thermal protection	Media Temperature max. °C	Fan weight kg	Density of media kg/m³	Installation type (ISO 5801)	Article number	
DDMB 9/7									
M601 +EKE07-0065	IP54	F	EXT	40	17.9	1.2	B	6M0401	

(5) = Stepless speed controllable via electronic Commutation Unit
 The fans must be used with the Electrical Commutation Unit EKE07.

Attention! We suggest to do not use the fan in the grey marked area! The noise ratings given in the performance curves are sound power level L_{WA7} , see „Technical Description“.

Dimensions in mm, subject to change.

DDMB 9/7 M601

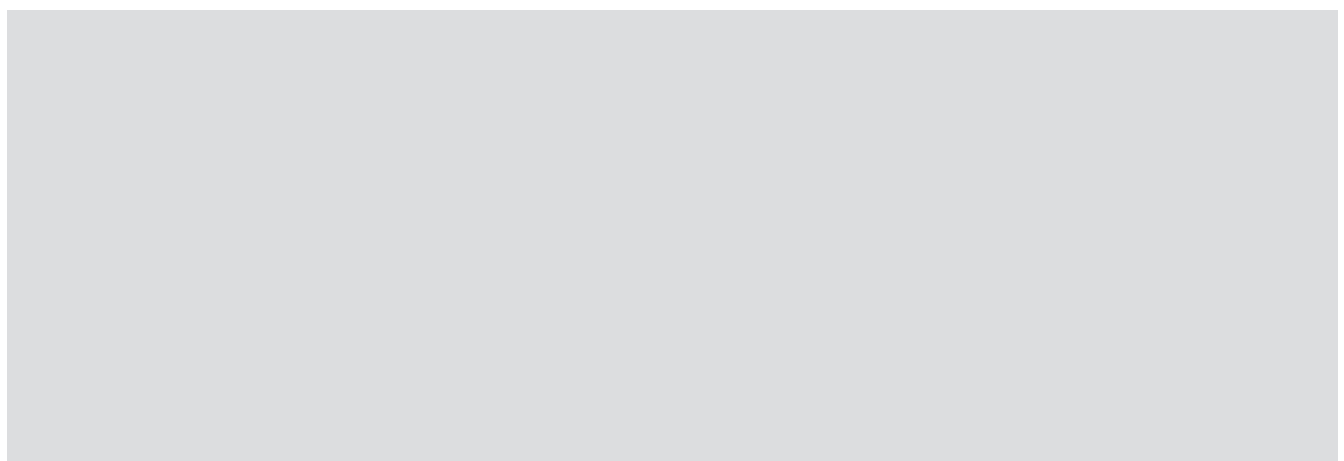
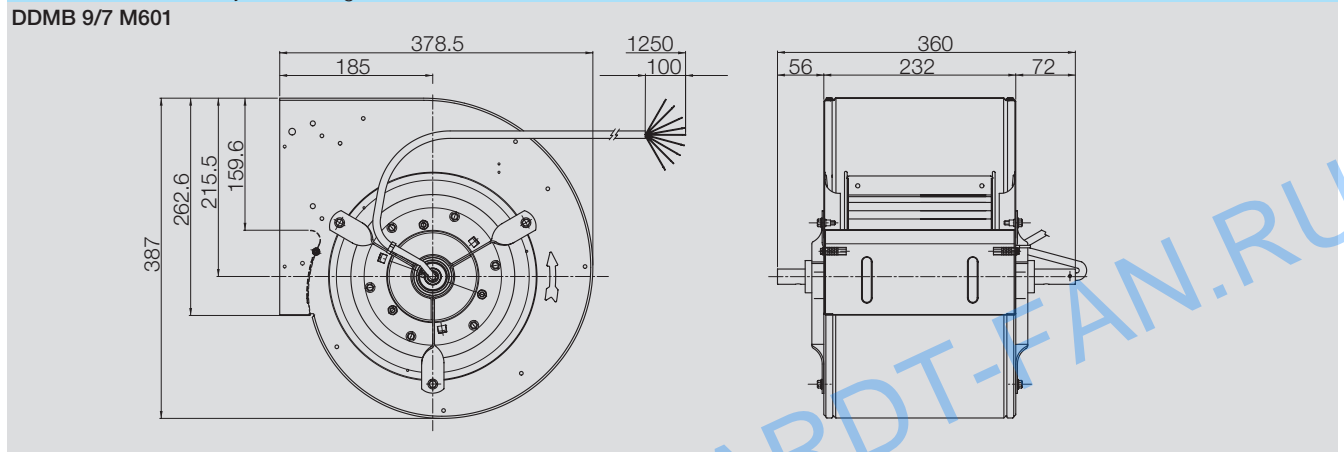

DDMB-9/7 TIGHT

Technical Data

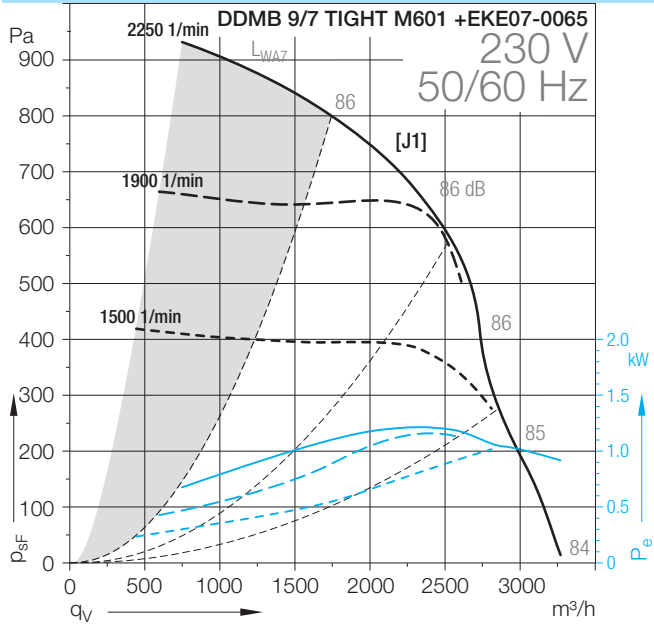

NICOTRA-GEBHARDT-FAN.RU

DDMB-9/7 TIGHT

Technical Data									
	Speed control	Curves	Nominal motor power W	Mains voltage V	Phases	Mains frequency Hz	Max. power consumption W	Max. input current A	Speed 1/min
DDMB 9/7 TIGHT									
M601 +EKE07-0065	(5)	[J1]	560	230	1~	50/60	1200	5.1	2250

Technical Data									
	Motor protection class	Motor thermal class	Thermal protection	Media Temperature max. °C	Fan weight kg	Density of media kg/m³	Installation type (ISO 5801)	Article number	
DDMB 9/7 TIGHT									
M601 +EKE07-0065	IP54	F	EXT	40	17	1.2	B	6M0403	

(5) = Stepless speed controllable via electronic Commutation Unit
 The fans must be used with the Electronic Commutation Unit EKE07.

Attention! We suggest to do not use the fan in the grey marked area! The noise ratings given in the performance curves are sound power level L_{WA7} , see „Technical Description“.

Dimensions in mm, subject to change.

DDMB 9/7 TIGHT M601

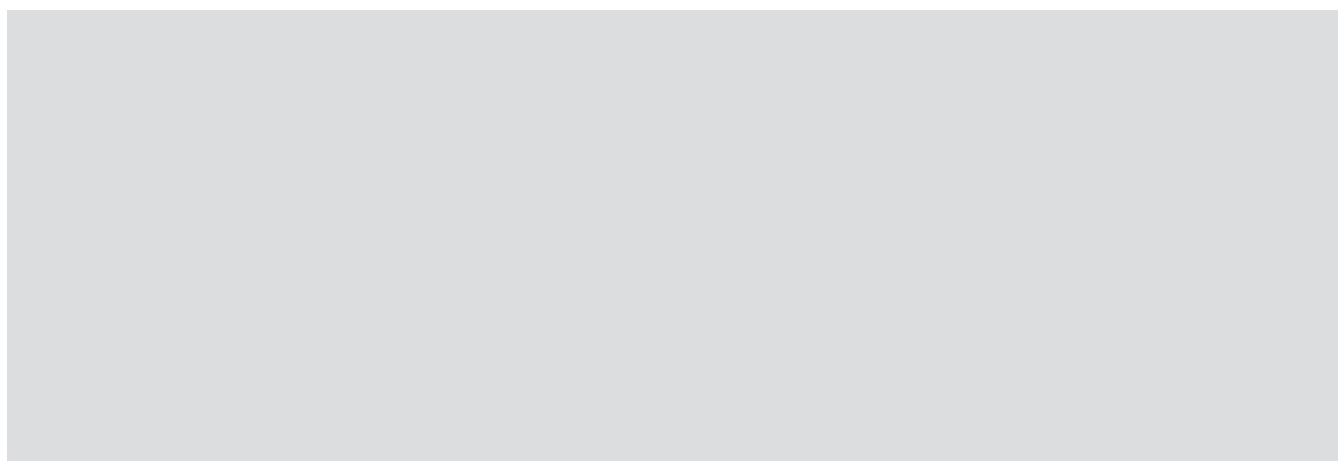
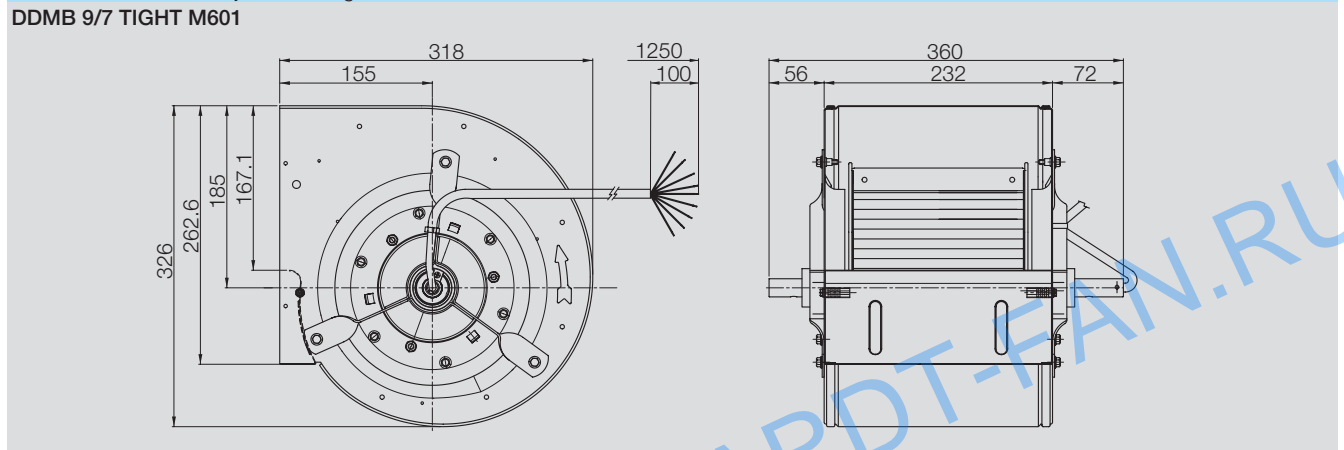

DDMB-9/9

Technical Data

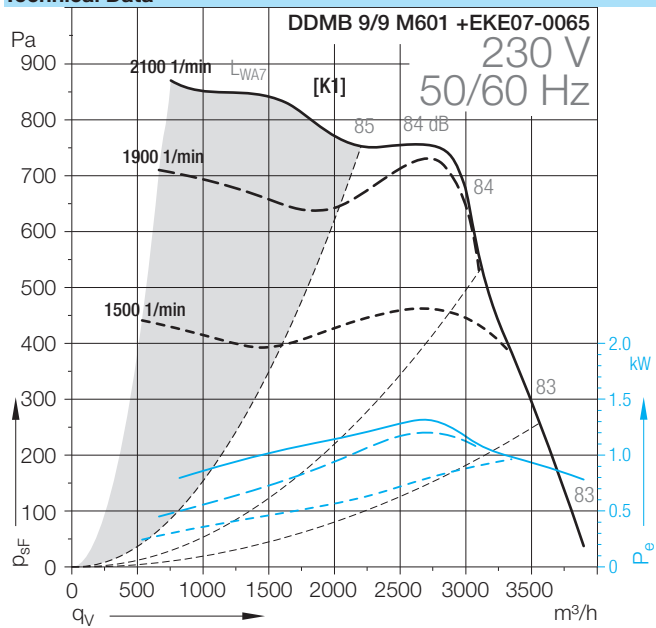

NICOTRA-GEBHARDT-FAN.RU

DDMB-9/9

Technical Data									
	Speed control	Curves	Nominal motor power W	Mains voltage V	Phases	Mains frequency Hz	Max. power consumption W	Max. input current A	Speed 1/min
DDMB 9/9									
M601 +EKE07-0065	(5)	[K1]	560	230	1~	50/60	1300	5.6	2100

Technical Data									
	Motor protection class	Motor thermal class	Thermal protection	Media Temperature max. °C	Fan weight kg	Density of media kg/m³	Installation type (ISO 5801)	Article number	
DDMB 9/9									
M601 +EKE07-0065	IP54	F	EXT	40	18.9	1.2	B	6M0402	

(5) = Stepless speed controllable via electronic Commutation Unit
 The fans must be used with the Electrical Commutation Unit EKE07.

Attention! We suggest to do not use the fan in the grey marked area! The noise ratings given in the performance curves are sound power level L_{WA7} , see „Technical Description“.

Dimensions in mm, subject to change.

DDMB 9/9 M601

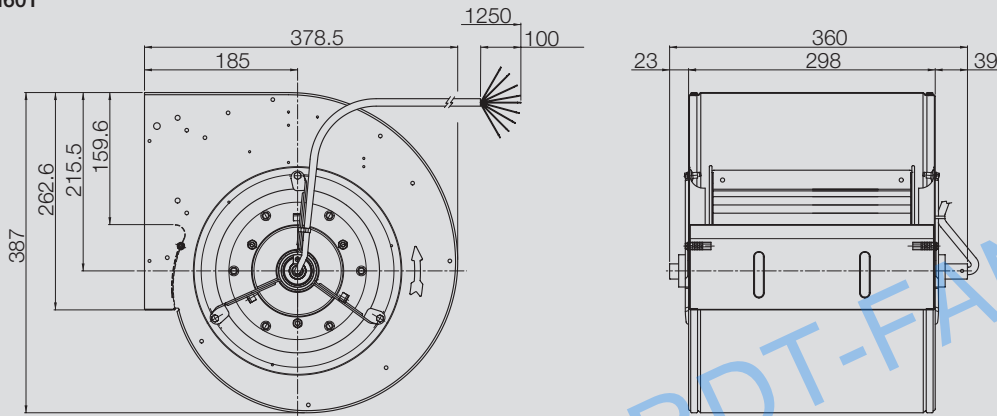

NICOTRA-GEBHARDT-FAN.RU

DDMB-9/9 TIGHT

Technical Data

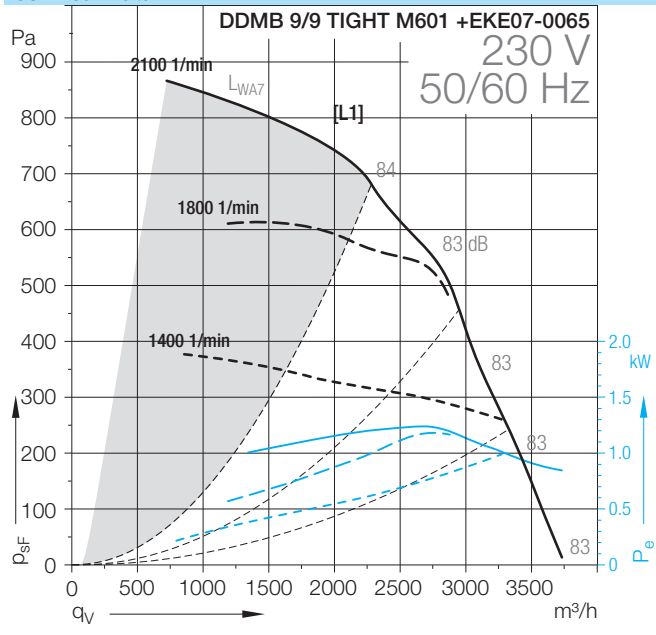

NICOTRA-GEBHARDT-FAN.RU

DDMB-9/9 TIGHT

Technical Data									
	Speed control	Curves	Nominal motor power W	Mains voltage V	Phases	Mains frequency Hz	Max. power consumption W	Max. input current A	Speed 1/min
DDMB 9/9 TIGHT									
M601 +EKE07-0065	(5)	[L1]	560	230	1~	50/60	1250	5.3	2100

Technical Data									
	Motor protection class	Motor thermal class	Thermal protection	Media Temperature max. °C	Fan weight kg	Density of media kg/m³	Installation type (ISO 5801)	Article number	
DDMB 9/9 TIGHT									
M601 +EKE07-0065	IP54	F	EXT	40	18	1.2	B	6M0404	

(5) = Stepless speed controllable via electronic Commutation Unit
 The fans must be used with the Electronic Commutation Unit EKE07.

Attention! We suggest to do not use the fan in the grey marked area! The noise ratings given in the performance curves are sound power level L_{WA7} , see „Technical Description“.

Dimensions in mm, subject to change.

DDMB 9/9 TIGHT M601

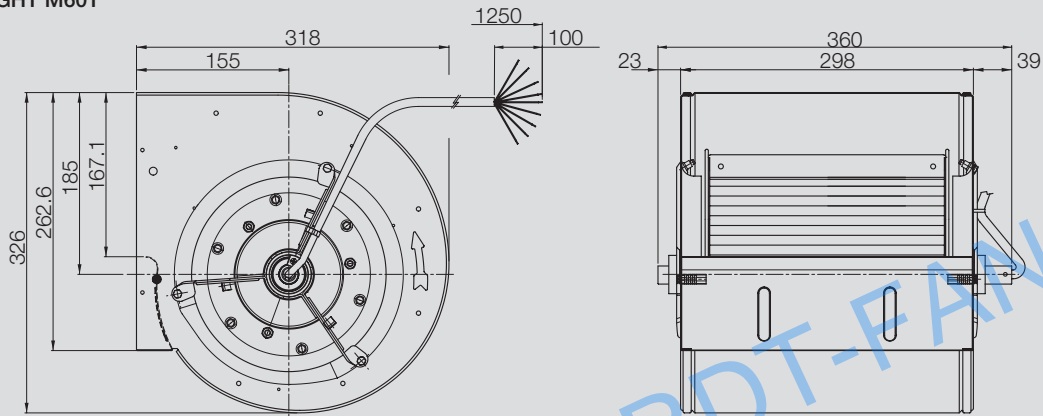

DDMB-10/8

Technical Data

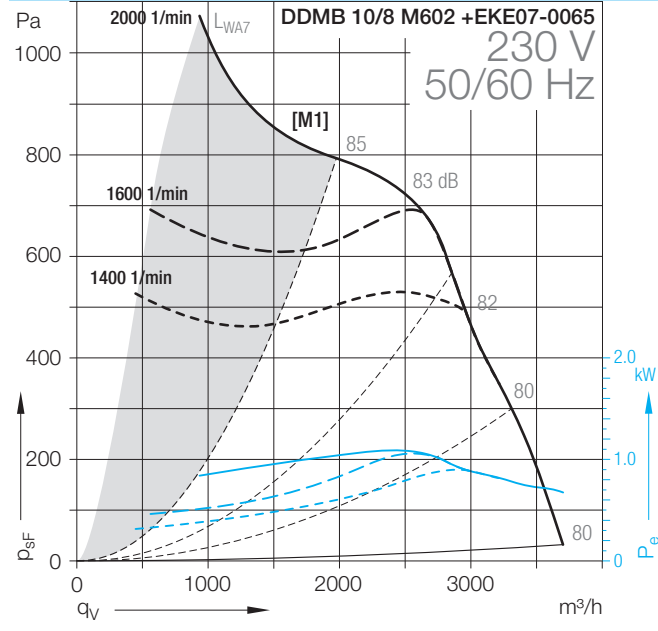

NICOTRA-GEBHARDT-FAN.RU

DDMB-10/8

Technical Data									
	Speed control	Curves	Nominal motor power W	Mains voltage V	Phases	Mains frequency Hz	Max. power consumption W	Max. input current A	Speed 1/min
DDMB 10/8									
M602 +EKE07-0065	(5)	[M1]	560	230	1~	50/60	1150	4.8	2000

Technical Data									
	Motor protection class	Motor thermal class	Thermal protection	Media Temperature max. °C	Fan weight kg	Density of media kg/m³	Installation type (ISO 5801)	Article number	
DDMB 10/8									
M602 +EKE07-0065	IP54	F	EXT	40	19.4	1.2	B	6M0405	

(5) = Stepless speed controllable via electronic Commutation Unit
 The fans must be used with the Electronic Commutation Unit EKE07.

Attention! We suggest to do not use the fan in the grey marked area! The noise ratings given in the performance curves are sound power level L_{WA7} , see „Technical Description“.

Dimensions in mm, subject to change.

DDMB 10/8 M602

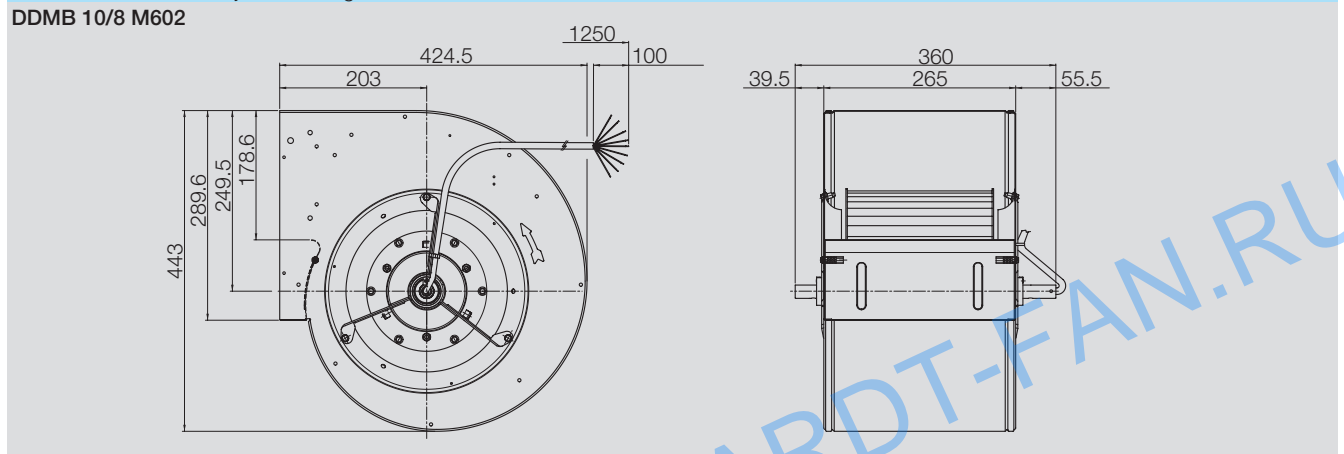

NICOTRA-GEBHARDT-FAN.RU

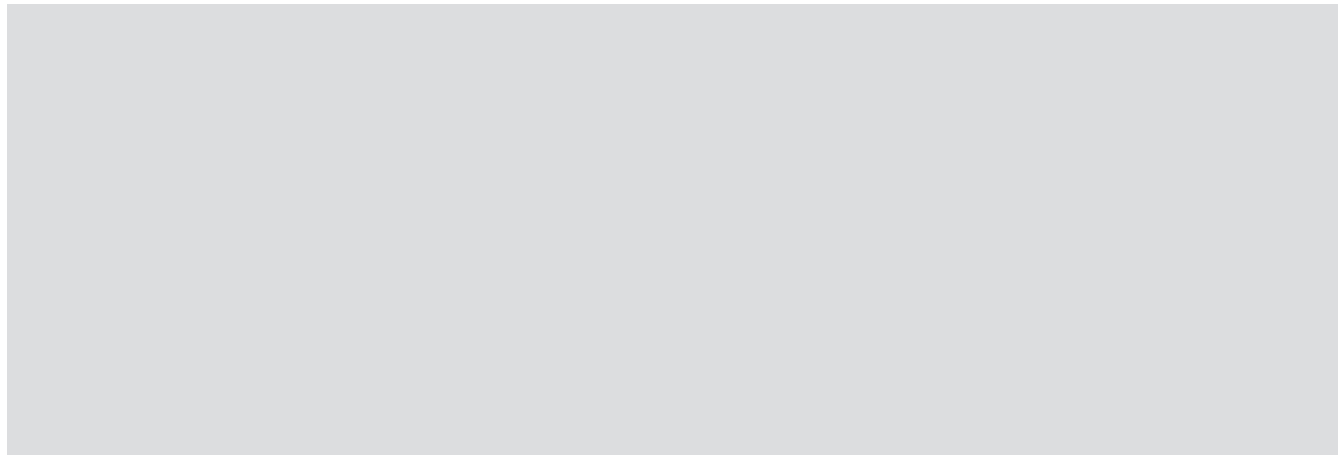

DDMB-10/10

Technical Data

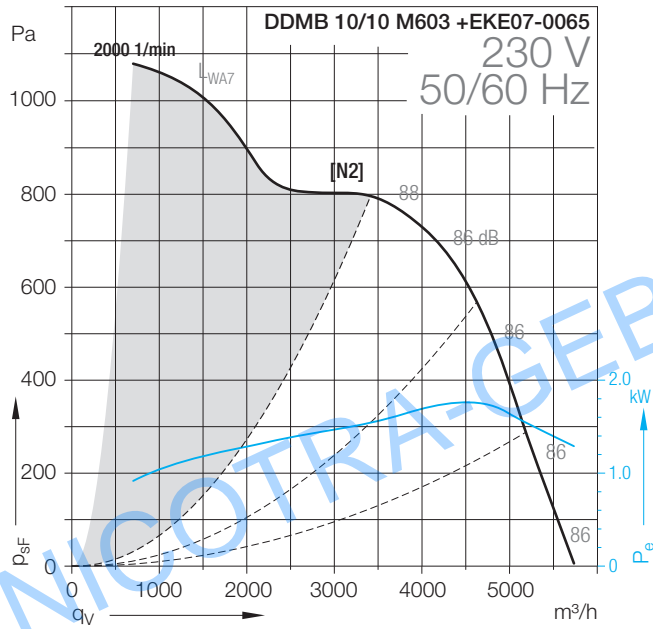
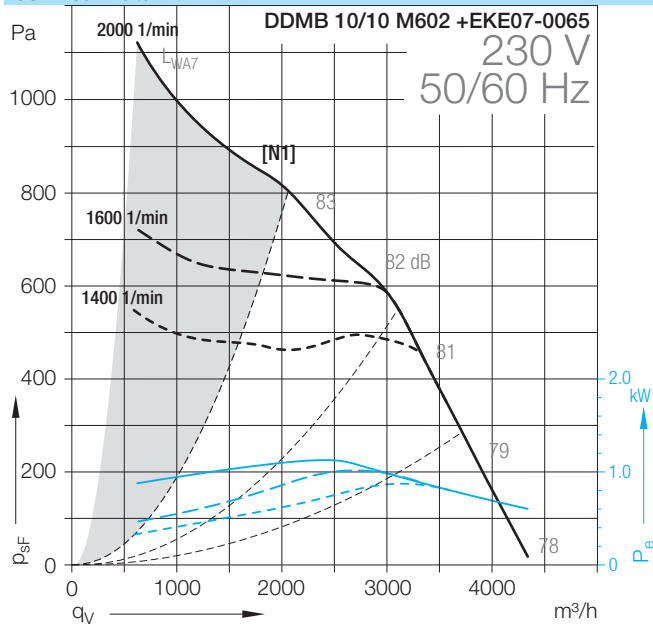

DDMB-10/10

Technical Data									
	Speed control	Curves	Nominal motor power W	Mains voltage V	Phases	Mains frequency Hz	Max. power consumption W	Max. input current A	Speed 1/min
DDMB 10/10									
M602 +EKE07-0065	(5)	[N1]	560	230	1~	50/60	1150	4.8	2000
M603 +EKE07-0065	(5)	[N1]	920	230	1~	50/60	1750	7.2	2000

Technical Data									
	Motor protection class	Motor thermal class	Thermal protection	Media Temperature max. °C	Fan weight kg	Density of media kg/m³	Installation type (ISO 5801)	Article number	
DDMB 10/10									
M602 +EKE07-0065	IP54	F	EXT	40	20.5	1.2	B	6M0406	
M603 +EKE07-0065	IP54	F	EXT	40	26.72	1.2	B	6M0407	

(5) = Stepless speed controllable via electronic Commutation Unit
 The fans must be used with the Electronic Commutation Unit EKE07.

Attention! We suggest to do not use the fan in the grey marked area! The noise ratings given in the performance curves are sound power level L_{WA7} , see „Technical Description“.

Dimensions in mm, subject to change.

DDMB 10/10 M602

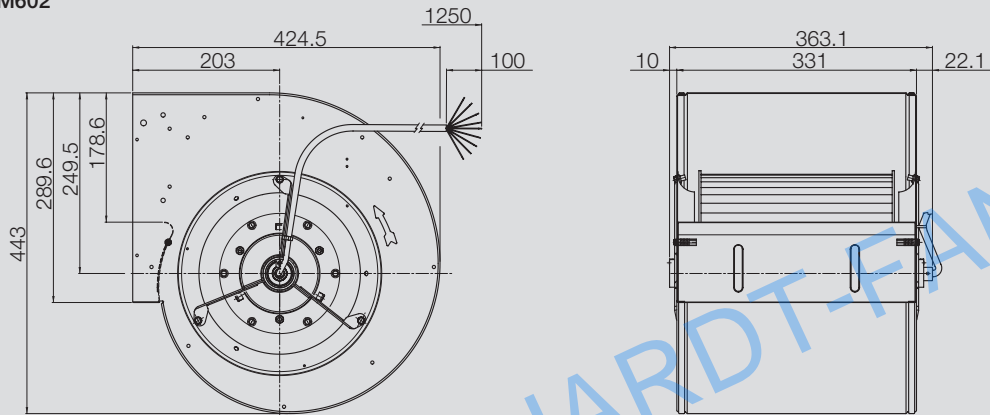

DDMB 10/10 M603

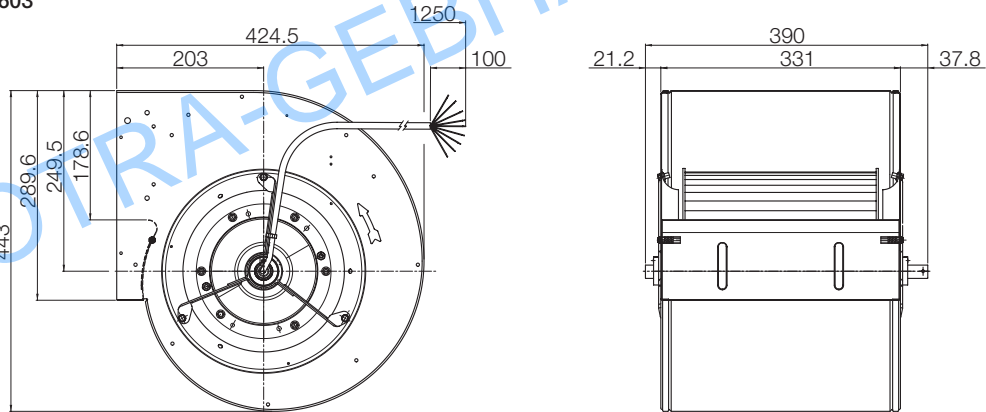

DDMB-12/9

Technical Data

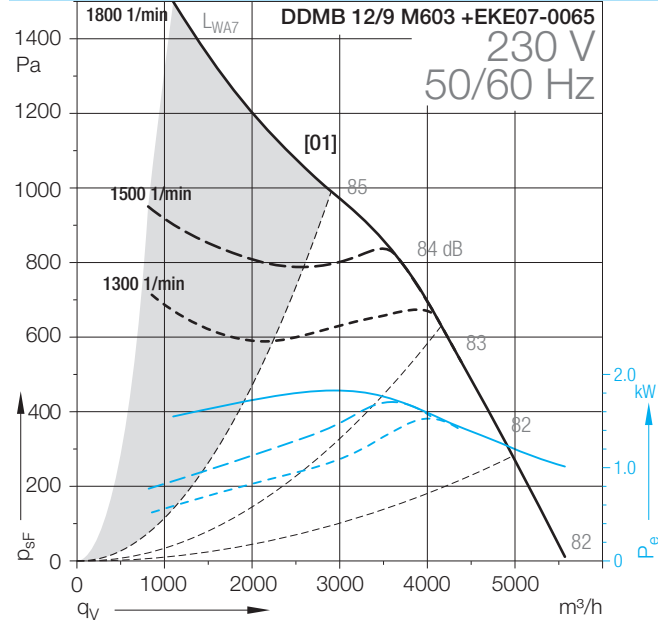

NICOTRA-GEBHARDT-FAN.RU

DDMB-12/9

Technical Data									
	Speed control	Curves	Nominal motor power W	Mains voltage V	Phases	Mains frequency Hz	Max. power consumption W	Max. input current A	Speed 1/min
DDMB 12/9									
M603 +EKE07-0065	(5)	[01]	920	230	1~	50/60	1800	7.6	1800

Technical Data									
	Motor protection class	Motor thermal class	Thermal protection	Media Temperature max. °C	Fan weight kg	Density of media kg/m³	Installation type (ISO 5801)	Article number	
DDMB 12/9									
M603 +EKE07-0065	IP54	F	EXT	40	29.83	1.2	B	6M0408	

(5) = Stepless speed controllable via electronic Commutation Unit
 The fans must be used with the Electronic Commutation Unit EKE07.

Attention! We suggest to do not use the fan in the grey marked area! The noise ratings given in the performance curves are sound power level L_{WA7} , see „Technical Description“.

Dimensions in mm, subject to change.

DDMB 12/9 M603

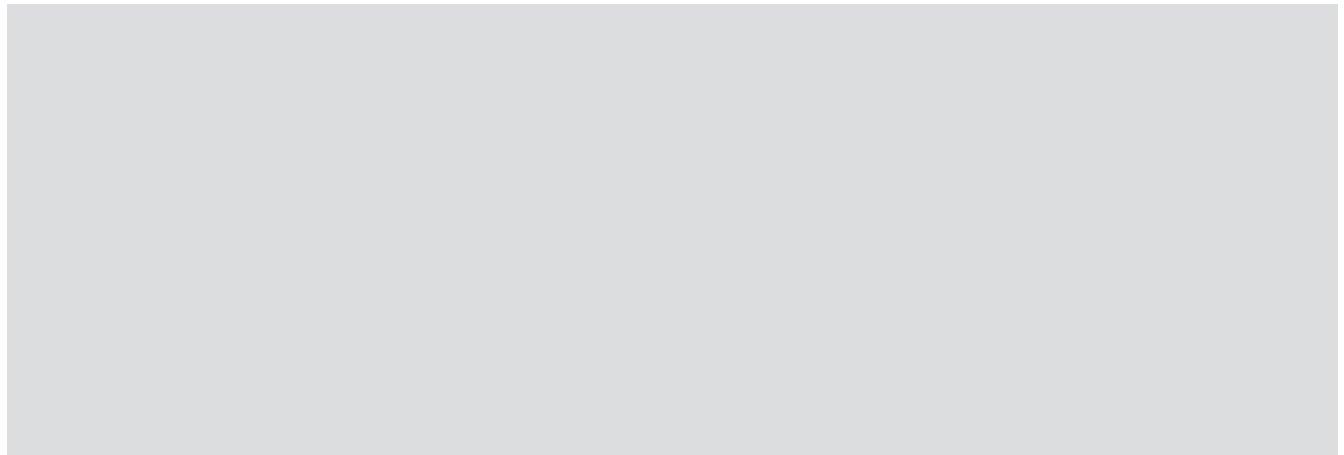
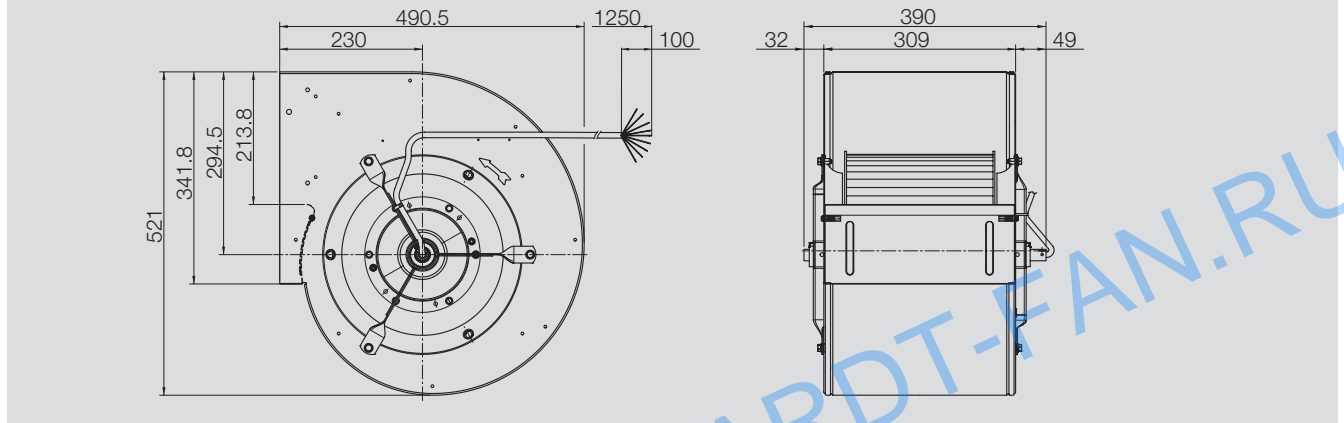

DDMB-12/12

Technical Data

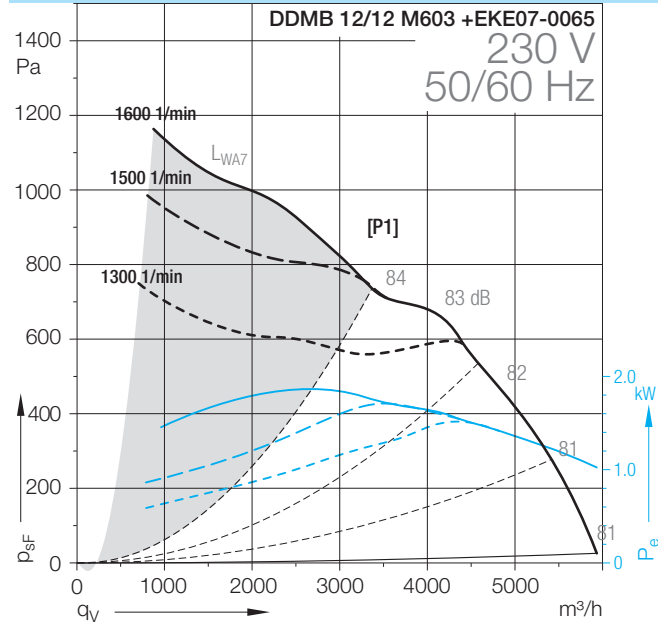

NICOTRA-GEBHARDT-FAN.RU

DDMB-12/12

Technical Data									
	Speed control	Curves	Nominal motor power W	Mains voltage V	Phases	Mains frequency Hz	Max. power consumption W	Max. input current A	Speed 1/min
DDMB 12/12									
M603 +EKE07-0065	(5)	[P1]	920	230	1~	50/60	1750	7.4	1600

Technical Data									
	Motor protection class	Motor thermal class	Thermal protection	Media Temperature max. °C	Fan weight kg	Density of media kg/m³	Installation type (ISO 5801)	Article number	
DDMB 12/12									
M603 +EKE07-0065	IP54	F	EXT	40	31.6	1.2	B	6M0409	

(5) = Stepless speed controllable via electronic Commutation Unit
 The fans must be used with the Electronic Commutation Unit EKE07.

Attention! We suggest to do not use the fan in the grey marked area! The noise ratings given in the performance curves are sound power level L_{WA7} , see „Technical Description“.

Dimensions in mm, subject to change.

DDMB 12/12 M603

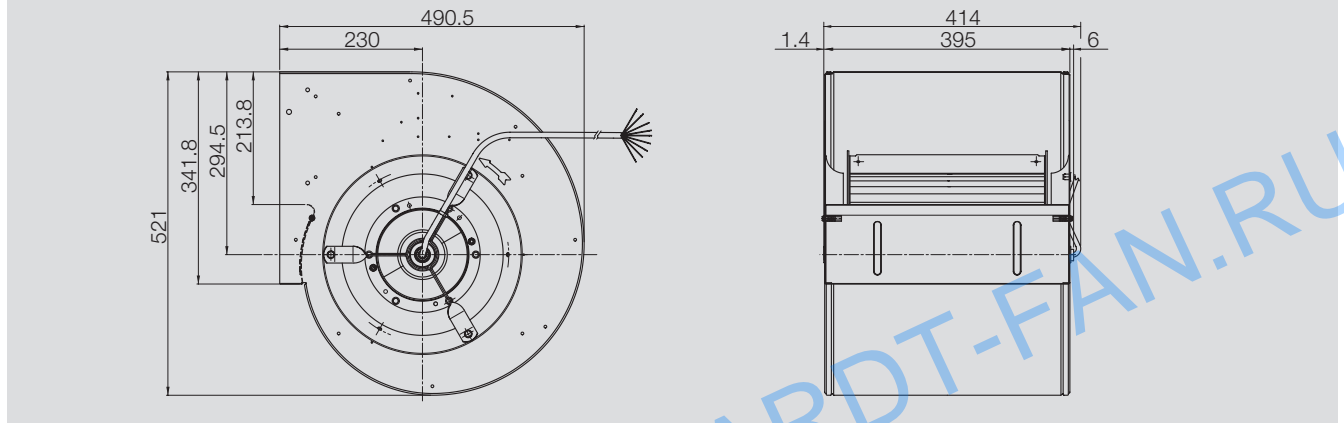

NICOTRA-GEBHARDT-FAN.RU

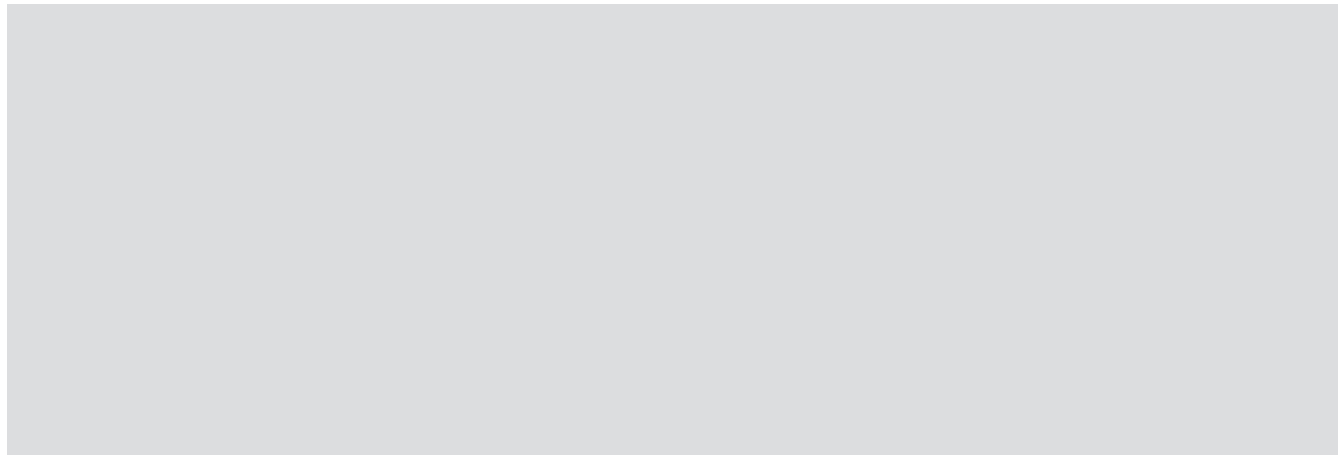

DDMB

Specifications

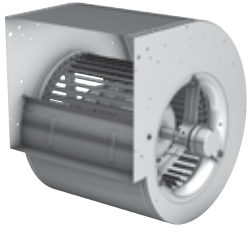

High performance centrifugal fan DDMB

Double width, double inlet (DWDI), direct driven forward curved blades fan. Lap-jointed scroll of galvanized steel (EN10142) assembled through a high technology roller-lock seaming (sizes ≥7 inches), spot-welded scroll of galvanized steel (sizes <7 inches). Straight cut off plate at fan outlet.

Impeller with forward curved blades of galvanized steel, directly mounted on a brushless DC "External rotor" motor, optimal motor cooling and no transmission losses.

High efficient brushless DC motor with external control unit – no obstruction of intake; continuously variable speed control with integrated active PFC and brownout protection, drive system complete in protection class IP54, 50/60Hz, 0...5V/0...10V, Modbus RTU.

Maintenance free, vibration isolaton pads. Impeller dynamically balanced according to ISO 1940.

Different fan sizes, options and accessories available - see technical data.

Fan data

Fan type		
Volume flow	q_v		m ³ /h
Static pressure	p_{sF}		Pa
Air density at fan inlet	ρ_1		kg/m ³
Air temperature	t		°C
Max. power consumption	P_e		kW
Speed	N		1/min
Frequency	f		Hz
Sound power level (A weighted)	L_{WA}		dB
Weight	m		kg

Fittings / Accessories

- Outlet flange - O
- Outlet flexible connection - A (sizes ≥7/7)
- Mounting feet - O/A (sizes ≥7/7)
- Terminal box - O
- Inlet guard -O/A
- Outlet guard - O/A
- Powder-coating - O

Legend

O = Options

A = Accessory

O/A = The item could be delivered as an option or an accessory

Please, check availability of each individual option or accessory on each specific fan model.

Electrical commutation unit

Electrical commutation unit

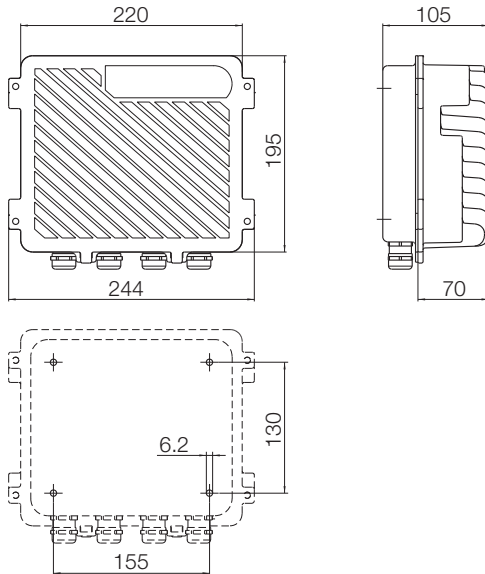
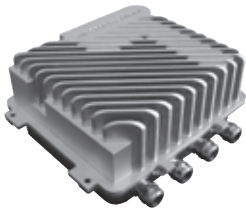

Execution

Controller EKE07 with single phase input and variable output voltage and frequency, especially designed to operate forward curved fans with brushless DC motors. By using modern power semiconductors a high efficiency at any speed is guaranteed.

Specification

- suitable exclusively for operating Nicotra Gebhardt brushless DC motors
- for single phase supply 230V/50-60Hz – input power up to 1.8kW
- internal speed-, power- and motor current limitation can be adjusted according to the connected fan type simply by dip switches
- integrated active Power Factor Correction (power factor >95%)
- Modbus RTU serial interface
- analogue interface 0...5V/0...10V
- dry error contact (max. 24V DC/250mA)
- protection class IP54 (protected against dust and splashing water)
-

Standards and guide lines

European Low Voltage Directive

The Controller EKE07 complies to the requirements of the Low Voltage Directive 2006/95/EC. The unit has been manufactured according to the standard:

EN 60146-1-1 (Semiconductor converters - General requirements and line commutated converters)

European EMC Directive

The Controller EKE07 is supplied exclusively in connection with products of the company Nicotra Gebhardt. The unit is fully integrated in the corresponding products and then complies to all requirements of the EMC directive, according to the EMC product standard for electrical drives with variable speed EN 61800-3.

European Machinery Directive

The Controller EKE07 does not impinge on the application field of the Machinery Directive.

Interface

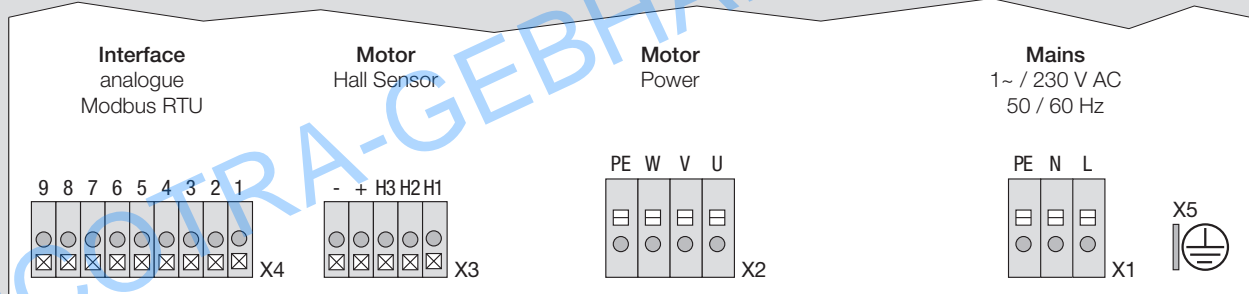

Performance

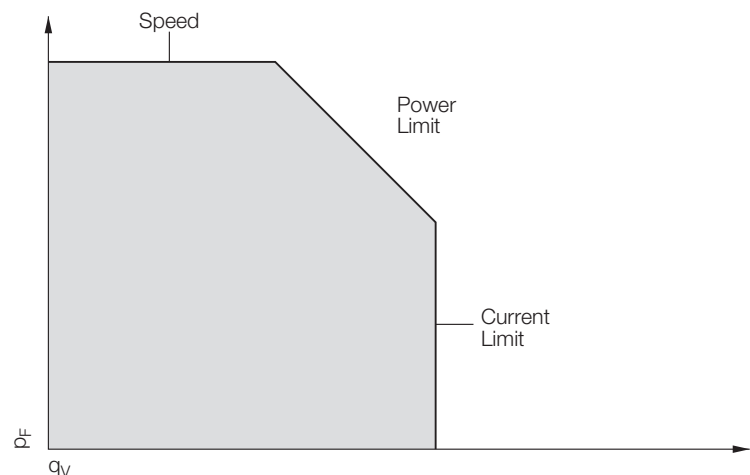

The exact limits depend on the fan type selected by dip switches.

Fittings / Accessories

Accessories

All options and accessories must be specified separately. Please take the technical data and dimensions from the corresponding page of the catalogue.

Flanges



Made from galvanized or painted steel, to connect ducts and system components to the fan outlet side.

Dimensions in mm, subject to change.

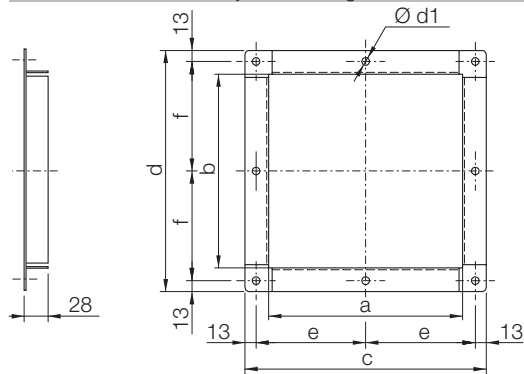

DDMB	a	b	c	d	e	f	Ø d1
7/7	232	201	288	257	131	115.5	9
9/7	232	255	288	311	131	142.5	9
9/7 TIGHT	232	263	288	311	131	142.5	9
9/9	298	255	354	311	164	142.5	9
9/9 TIGHT	298	263	354	311	164	142.5	9
10/8	265	284	321	340	147.5	157	9
10/10	331	284	387	340	180.5	157	9
12/9	309	334	365	390	169.5	182	9
12/12	395	334	451	390	212.5	182	9

Flexible connection

Flexible connection to connect the fan to system components or units, absorbing and stopping the vibration transmission.

Dimensions in mm, subject to change.

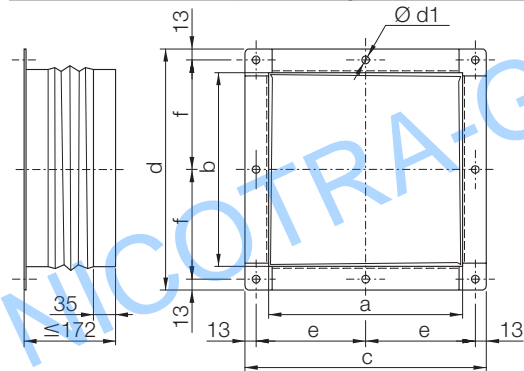

DDMB	a	b	c	d	e	f	Ø d1
7/7	232	201	288	257	131	115.5	9
9/7	232	255	288	311	131	142.5	9
9/7 TIGHT	232	263	288	311	131	142.5	9
9/9	298	255	354	311	164	142.5	9
9/9 TIGHT	298	263	354	311	164	142.5	9
10/8	265	284	321	340	147.5	157	9
10/10	331	284	387	340	180.5	157	9
12/9	309	334	365	390	169.5	182	9
12/12	395	334	451	390	212.5	182	9

Dimensions in mm, subject to change.

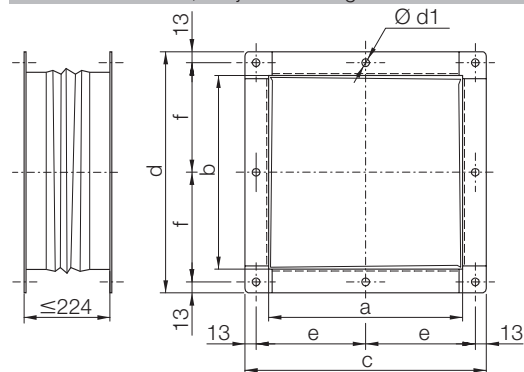

DDMB	a	b	c	d	e	f	Ø d1
7/7	232	201	288	257	131	115.5	9
9/7	232	255	288	311	131	142.5	9
9/7 TIGHT	232	263	288	311	131	142.5	9
9/9	298	255	354	311	164	142.5	9
9/9 TIGHT	298	263	354	311	164	142.5	9
10/8	265	284	321	340	147.5	157	9
10/10	331	284	387	340	180.5	157	9
12/9	309	334	365	390	169.5	182	9
12/12	395	334	451	390	212.5	182	9

Fittings / Accessories

Mounting feet

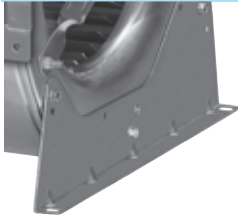

Feet made from galvanized steel, either mounted or loose, enable the fan to be installed with a 0, 90 and 270 orientation.

Dimensions in mm, subject to change.

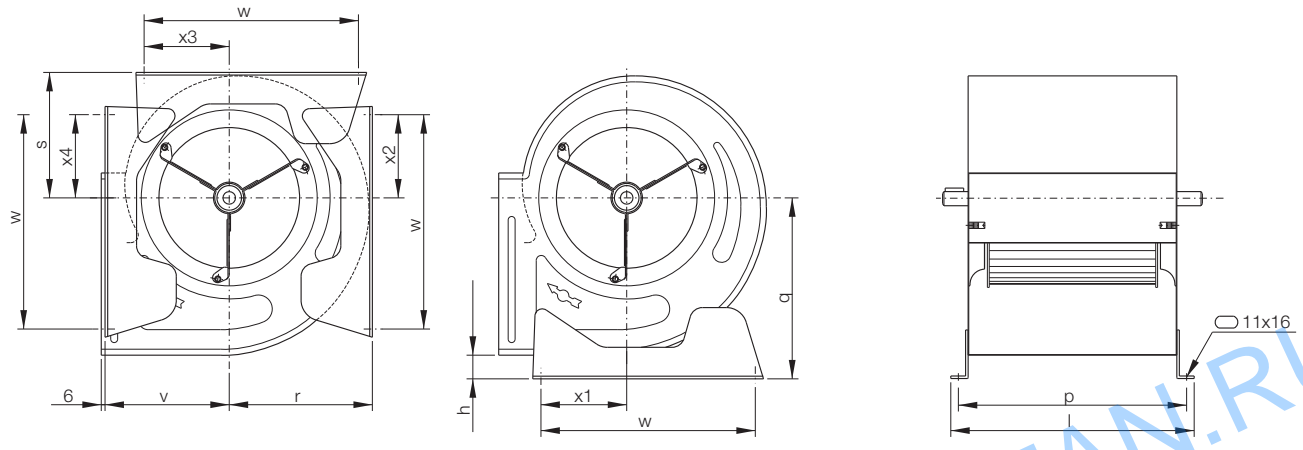

DDMB	h	l	p	q	r	s	v	w	x1	x2	x3	x4
7/7	17	282	258	203	169	145	147	225	117	86	88	47
9/7	38	282	258	253	199	177	179	300	119	124	123	120
9/7 TIGHT	17	282	258	202	170	149	–	225	120	86	97	–
9/9	38	348	324	253	199	177	179	300	119	124	123	120
9/9 TIGHT	17	348	324	202	170	149	–	225	120	86	97	–
10/8	38	315	291	287	227	198	197	340	136	132	135	132
10/10	38	381	357	287	227	198	197	340	136	132	135	132
12/9	38	359	335	332	266	232	224	408	161	153	161	153
12/12	38	445	421	332	266	232	224	408	161	153	161	153

Protection guards



The fans are designed for installation in equipment and as standard are not equipped with protective guards.

They should not be put into operation before all protective devices are fitted and connected!

Protective measures must be carried out as set out in DIN EN ISO 12100 "Safety of machinery - Basic concepts, general principles for design".

If the application of the fan allows free access to the inlet and discharge apertures, safety devices must be put in place on the fan in accordance with DIN EN ISO 13857! Suitable safety guards are available as an optional extra.

Increased corrosion protection

Nicotra Gebhardt fans are provided – as a standard equipment – with a highly efficient corrosion protection but, in the event of extremely high corrosion risk, additional corrosion protections might be required.

Following to the application and corrosion stress conditions, special coatings of various types and thickness can be supplied on request.

Fittings / Accessories

Speed regulator module REGPOT



REGPOT1 and REGPOT2 are devices used to give variable voltage by inside rotating. It's possible regulate minimum voltage. STOP function is implemented. REGPOT series are used to control voltage controlled electronic devices (DRIVER, Electronic motor, brushless inverter).

Dimensions in mm, subject to change.

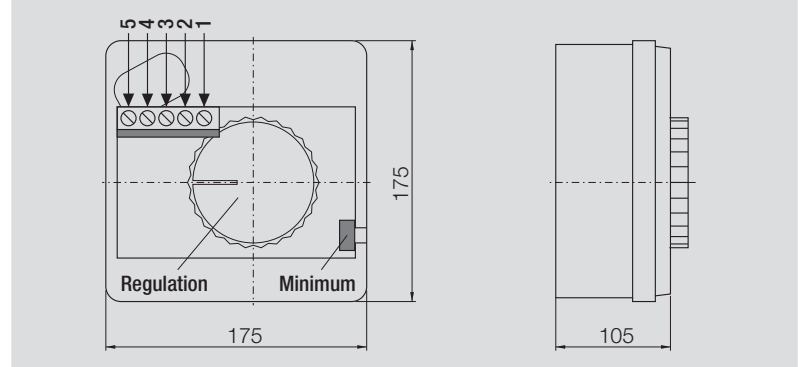

Wiring Diagram

REGPOT1

without STOP

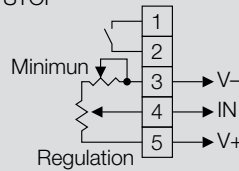

with STOP

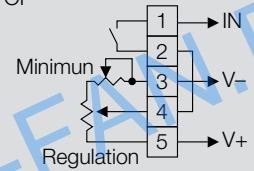

Wiring Diagram

REGPOT2

without STOP

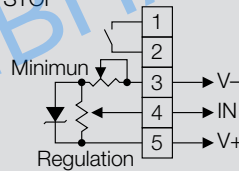

with STOP

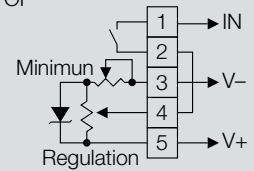

Description

Safety

These fans are intended to be incorporated into finished products for the treatment of clean and filtered air, free of dust, particles, shavings, grease, etc., within the rated ranges of temperature and electrical supply.

The design of the installation shall guarantee the essential safety requirements, as specified by the locally enforceable legislation, including safety against human contact with moving parts, e.g. by application of the design principles stated in EN ISO 12100.

When the inlet and/or outlet of a fan are connected to a ducting system, or to a closed plenum, including integral filters or grids, these may be designed also to provide the specified protection level.

Otherwise, the fan must be protected by fitting appropriate inlet or outlet guards, designed in accordance with EN ISO 13857, available from Nicotra Gebhardt as accessories or options.

Type code

1F 3F	2P 4P 6P	1V 2V 3V 4V	FL	SCT	SP	SB	GRG	GRGP
Single phase Three phase	2-pole 4-pole 6-pole	1-Speed 2-Speeds 3-Speeds 4-Speeds	Outlet flange	Terminal box	Special version	Mounting Feet	Inlet guard	Outlet guard

Performance data

Air performance ratings shown in this catalogue have been derived from performance tests made with installation type "B", with free inlet and ducted outlet.

The performance data shall be obtained in a laboratory registered by AMCA for AMCA 210/99 air performance testing. Data are not certified by AMCA.

Ratings are referred to the standard air density of $\rho_1 = 1.2\text{kg/m}^3$ at the fan inlet.

Sound

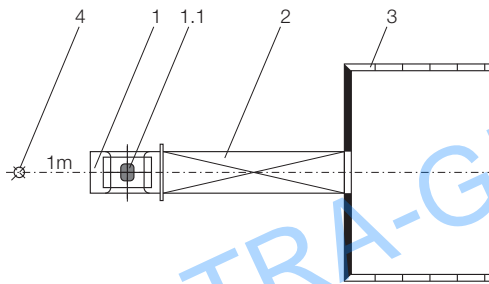

In the diagrams, the A-weighted housing and free inlet sound power level L_{WA7} is given as the emission parameter for the ventilator.

The A-weighted noise level L_{pA7} for a distance of 1m (see sketch) is achieved approximately in that the correction value given below is subtracted from the respective A sound power level.

It should be noted that site acoustics, duct design, reverberation, natural frequencies etc. can all influence noise to a greater or a lesser extent.

$$L_{pA7} \approx L_{WA7} - dL$$

Correction values dL:
 Size $\leq 10/10$: dL = **11dB**
 Size $\geq 12/9$: dL = **13dB**

- 1 = Fan
- 1.1 = Motor
- 2 = duct on discharge
- 3 = Chamber
- 4 = Microphone position

Motors

These brushless DC external rotor motors (BLDC) are especially designed. They have an highest efficiency also in the partial load area.

Motor protection

The motors are protected via safe operating area (SOA). SOA defines the conditions (voltage, power, current, speed) over which the drive can be expected to operate without self-damage. The SOA of the DDMB is automatically guaranteed by the motor design and the controller settings. Additionally to that the motors are equipped with thermo contact (PTO) to protect the motors against thermal overload.

Speed regulation

The speed limits are defined by the presetting of the dip switches and the winding configuration. Between that limits the speed can be controlled via analogue (0...5V or 0...10V) or MODBUS-interface.

Description

Fan operating area

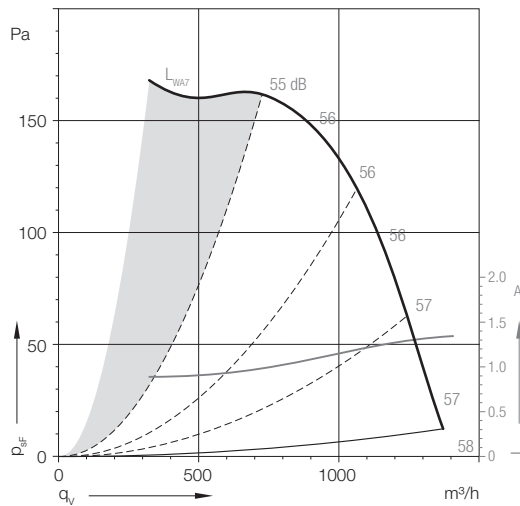

For a proper fan selection the duty point in the grey area to the left of the leftmost dashed parabolic line drawn on each performance diagram should preferably be avoided. In this area the fan stall is producing fluctuating pressure and fluctuating loads on the fan and motor; some motors may also be overheating in this low-load condition. When the performance curves of a fan are cut to the right with continuous-line parabola, a fan selection with the duty point located below of this parabola shall be carefully avoided, because the drive motor would be overloaded and would be overheating. Such an operating condition may be evidenced by a motor input current exceeding the maximum rated value.

Fan lifespan

The high level of manufacturing technology and the use of selected materials provide a considerable fan operating lifetime. Only the motor bearings are subject to wear in most applications. The calculated bearing life time L_{10h} is appr. 30,000 hrs.

Media

This range of fans are specially designed for use into air handling units (AHU) and ventilation systems. The centrifugal fans are ideal for conveying clean air. The allowed air temperature comes from -20°C to +40°C.

Accessories

Frequency converter



Design

Frequency inverter with variable output voltage and frequency, specially designed for the operation of centrifugal fans with induction motors. Due to the use of modern power semiconductors it is possible to achieve a speed of revolution with high efficiency. Switching frequencies up to 16kHz can be set with all types. If the highest switching frequencies are required (for example for reasons of noise reduction), the maximum output current is decreased, in which case the performance category should be specially checked.

The overall package includes the frequency inverter, filter for class B (for residential and commercial uses) as well as a control unit.

General Performance characteristics

Motor protection feature for motors with thermistor temperature sensors, adjustable acceleration and deceleration ramps, minimum and maximum rotation speeds, fixed rotation speeds, trapping switch during operation, programmable inputs and PI-controller (MM420 and MM430 only), RS485 serial interface as well as a detailed operating instructions. Caution about combination with isolators (ESH)! Special EMC-action can be necessary, furthermore do not switch during operation, overvoltages can destroy the switch and the motor-winding.

Performance range G110 1AC 230V (for single-phase AC supply)

0.25kW to 2.2kW rated motor power, 200V to 240V 10% single-phase AC, 47Hz up to 63Hz, three-phase current output 3x230V AC, protection class IP20. Permitted ambient temperature during operation: -10°C up to +40°C.

Performance range MM420 3AC 400V (for three-phase AC supply)

0.55kW to 11kW rated motor power, 380V to 480V 10% three-phase AC, 47Hz up to 63Hz, three-phase current output 3x400V AC, protection class IP20. Permitted ambient temperature during operation: -10°C up to +50°C. The interference suppression filter required to comply with the EMC basic interference suppression standard EN 50081-1 (residential and commercial uses) is integrated into the package as substructure option. Power choke to comply with EN 61000-3-2 as additional component.

Observe performance reduction when using high clock frequencies!

Performance range MM430 3AC 400V

(for three-phase AC supply)

15kW to 250kW rated motor power, 380V to 480V 10% three-phase AC, 47Hz up to 63Hz, three-phase current output 3x400V AC, protection class IP20.

Permitted ambient temperature during operation: -10°C up to +50°C. The interference suppression filter required to comply with the EMC basic interference suppression standard EN 50081-1 (industrial applications) is partially integrated. In order to attain EMC requirements Class B a frequency inverter without filter should be selected. The appropriate EMC-B filter is then required as an additional component.

Observe performance reduction when using high clock frequencies!

The indicated ratings of the units are made for a quick selection. The exact dedication of an inverter in this catalogue is made by taking into account of the max. admitted current at a pulse frequency of 4kHz. It is important to know that at higher pulse frequencies the supplied current of the inverter will be decreasing, with the possible consequences of having to select a larger inverter unit. Also longer feed lines or additional radio frequency filters may lead to the choice of a larger inverter size.

The selected frequency inverters (G110 und MM420) are units contains the frequency inverter (as shown in the following tables) with the matching interference suppression filter (Class B) and a control panel. A further component is the line choke which is available as an accessory. For more information the available frequency inverters are shown in the following tables.

Accessories

Frequency converter

Technical Data | Dimensions

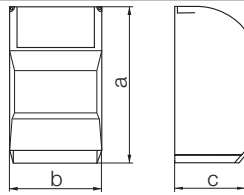

For three-phase AC motors on the single-phase supply.

6SL3211-	Nominal power kW	Nominal current A	a mm	b mm	c mm	Weight kg
0AB12-5BA0	0.25	1.7	150	90	116	0.8
0AB13-7BA0	0.37	2.3	150	90	116	0.8
0AB15-5BA0	0.55	3.2	150	90	131	0.9
0AB17-5BA0	0.75	3.9	150	90	131	0.9
0AB21-1AA0	1.1	6	160	140	142	1.5
0AB21-5AA0	1.5	7.8	160	140	142	1.5
0AB22-2AA0	2.2	11	181	184	152	2.1

Technical Data | Dimensions

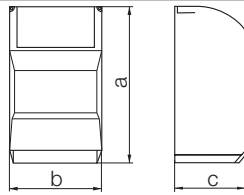

For three-phase AC motors on the three-phase supply

6SE6420-	Nominal power kW	Nominal current A	a mm	b mm	c mm	Weight kg
2UD15-5AA1	0.55	1.6	173	73	149	1
2UD17-5AA1	0.75	2.1	173	73	149	1
2UD21-1AA1	1.1	3	173	73	149	1
2UD21-5AA1	1.5	4	173	73	149	1
2AD22-2BA1	2.2	5.9	202	149	172	3.3
2AD23-0BA1	3	7.7	202	149	172	3.3
2AD24-0BA1	4	10.2	202	149	172	3.3
2AD25-5CA1	5.5	13.2	245	185	195	5
2AD27-5CA1	7.5	18.4	245	185	195	5
2AD31-1CA0	11	26	245	185	195	5

Technical Data | Dimensions

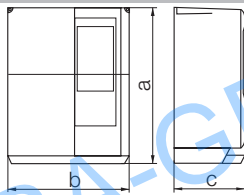

For three-phase AC motors on the three-phase supply

6SE6430-	Nominal power kW	Nominal current A	a mm	b mm	c mm	Weight kg
2AD31-5CA0	15	32	245	185	195	5.7
2AD31-8DA0	18.5	38	520	275	245	17
2AD32-2DA0	22	45	520	275	245	17
2AD33-0DA0	30	62	520	275	245	17
2AD33-7EA0	37	75	650	275	245	22
2AD34-5EA0	45	90	650	275	245	22
2AD35-5FA0	55	110	1150	350	320	75
2AD37-5FA0	75	145	1150	350	320	75
2AD37-8FA0	90	178	1150	350	320	75
2UD41-1FA0	110	180.4	1450	326	356	116
2UD41-3FA0	132	220	1450	326	356	116
2UD41-6GA0	160	265.8	1533	326	545	116
2UD42-0GA0	200	325.6	1533	326	545	116
2UD42-5GA0	250	419.8	1533	326	545	116

Motor protection unit



Motor protection unit EUM 33

Motor protection unit for three-phase current motors (standard motors) without thermal contacts.

Design

Plastic casing in protection class IP55, permissible ambient temperature +40°C, 40Hz up to 60Hz, frontal operation, for wall mounting. Motor protection unit for single-speed, non-variable speed three-phase current motors without thermal contacts.

Function

The motor protection units must be adjusted on site to the trigger current. If the preset trigger current is exceeded, the device disconnects the motor from the mains supply via a thermal overload release. Pressing the "on key" causes the unit to turn on again.

All motor protection units EUM33 are also suitable for the protection of EExe-motors (PTB-Prüfung Gesch-Nr. 3.35/386.3060). They must however be mounted outside of explosion endangered areas, since they are not themselves designed with explosion protection.

Technical Data

EUM 33-	Continuous current A	Setting range A	Max. nominal power kW
0004-8D	0.4	+0.2/+0.4	0.09
0006-8D	0.6	+0.4/+0.6	0.12
0010-8D	1	+0.6/+1	0.25
0016-8D	1.6	+1/+1.6	0.55
0024-8D	2.4	+1.6/+2.4	0.8
0040-8D	4	+2.4/+4	1.5
0060-8D	6	+4/+6	2.5
0100-8D	10	+6/+10	4
0160-8D	16	+10/+16	7.5
0200-8D	20	+16/+20	9
0250-8D	25	+20/+25	12.5
0500-8D	50	+25/+50	25
0580-8D	58	+50/+58	30

Dimensions in mm, subject to change.

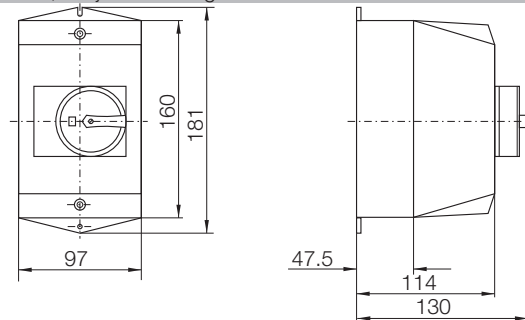

Wiring Diagram

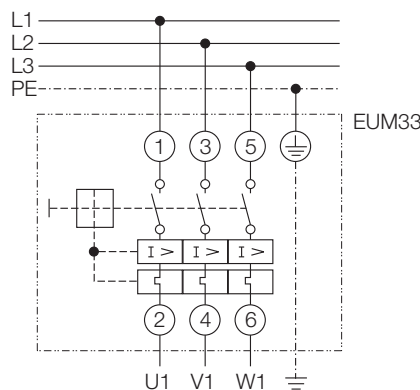

Accessories

Universal control device



Universal control device for installation in control cabinets Digital control module for controlling pressure, air velocity or volume flow (PI controller). For example, a transformer for fans is controlled via the 0...10V output. The device is designed for installation in control cabinets.

Type

Multi functional LC-display for actual and nominal values (m/s, hPa = mbar, 100m³/h). Menuassisted adjustment via three function keys.

Actual value input 0...10V e. g. for:

- air speed sensors Type EIL in measuring ranges from 0...1m/s and 0...10m/s e. g. for Air velocity control in clean room technology
- Pressure sensors Type EIP in measurement ranges 50Pa up to 4000Pa e. g. for Pressure control in canal systems of air conditioning systems (VVS) and Flow control in centrifugal fans with pressure tapplings in the inlet cone

The control module calculates the required flow (m³/h) from the differential measured pressure between the surrounding level and inlet cone.

- Output 0...10V e. g. for controlling a transformer
- Failure message is output via display (internal/external) and relay programmable
- External set value specification via potentiometer or 0...10V signal
- Specification of two set values (day/night), can be switched over externally or via keyboard
- Protection against unauthorised setting by keyboard code

Application area

- Pressure regulation for centralised ventilation systems and variable volume flow systems for building air conditioning (VVS) e.g. in combination with a frequency inverter or a commutation unit or a transformer and a pressure sensor
- Volume flow regulation for centrifugal fans (with measuring stub in the inlet cone) e.g. in combination with a frequency inverter or a commutation unit or a transformer or a mini-interface inverter and a pressure sensor and the volume flow volumeter
- Air speed regulation for clean room systems, e.g. in combination with a transformer and an air speed sensor

Electrical connection and installation

Connection to 230V, 50/60Hz. The control module can be installed in a control cabinet door. Admissible relative humidity: 85%, noncondensing. Power supply for the sensors included:

+24V, 20%, I_{max} = 70mA.

Setting options

- Set values in the measurement range of the sensor (m/s, hPa = mbar), or in the volume flow range of the fan (×100m³/h)
- Switch over of set value (day/night)
- Min./max. setting range
- Translation of performance curve (P component)
- Constant of integration can be selected (I component)
- Reversal of the effect of the control behaviour
- Rotation of the performance curve
- Switchover or programming of internal/external set value
- Sensor selection via keypad
- Programming for "Filter fault"
- Keypad code
- K factor entry (The K10-factor can be found in the current lists of our fan line)

Technical Data

	Input voltage V	Output voltage V	Max. output current mA	Motor protection class	Operating consumption VA	Operating temperature °C
ERA 02- 4000-5E	0/10	0/10	10	IP20	10	+0/+40

Accessories

Universal control device



Dimensions in mm, subject to change.

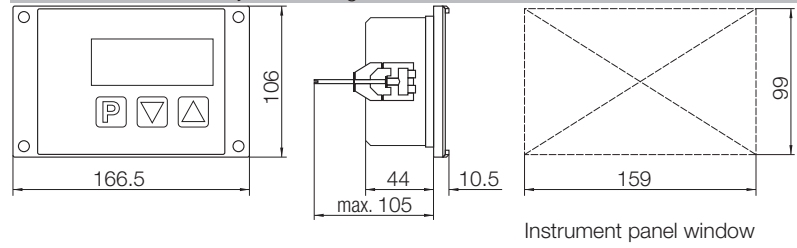

Wiring Diagram

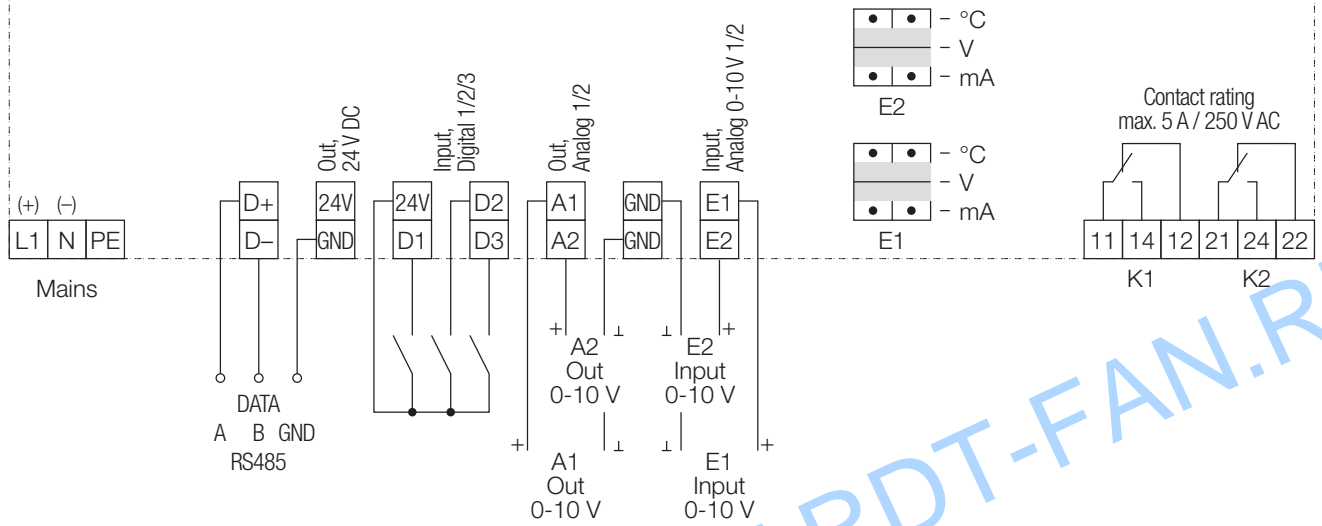

NICOTRA-GEBHARDT-FAN.RU

Differential pressure sensor



Differential pressure sensor with membrane for measuring the pressure, negative pressure or differential pressure of nonaggressive gases.

Type

The differential pressure to be measured acts transformed into an output signal of 0...10V by electronics (in SMD technology).

Application ranges

Volume flow regulators in centrifugal fans (with volume flow measuring device IMV) in connection with a frequency inverter type G110, MM420, MM430, or a universal regulator appliance type ERA 02-4000-5E in connection with a frequency regulator.

Electrical connection and installation

The differential pressure sensor delivers a starting signal (0...10V) by pressure increase at the "Plus" connection opposite pressure on the "Minus" connection.

Voltage supply

- 15...30V DC or 24V AC, 15%
- Pressure connections must point downward, tube connection ø5mm

Measuring accuracy

- Null drift: 0.75%
- Sum of linearity and hysteresis: 1%
- Temperature drift zero point: 0.3%/10K
- Temperature drift length of measurement: 0.2%/10K

Dimensions in mm, subject to change.

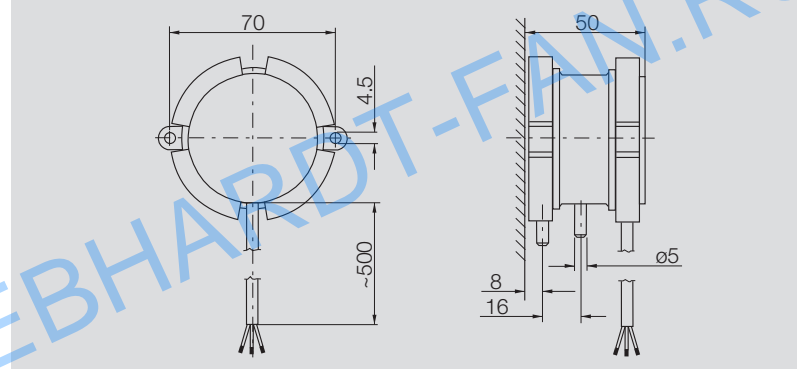

Technical Data

EIP 01-	Pressure range Pa	Motor protection class	Max. current consumption mA	Overload protection Pa	Output signal proportional V	Operating temperature °C
0200-12	+0/+200	IP65	12	20000	+0/+10	+0/+50
0500-12	+0/+500	IP65	12	20000	+0/+10	+0/+50
1000-12	+0/+1000	IP65	12	20000	+0/+10	+0/+50
2000-12	+0/+2000	IP65	12	20000	+0/+10	+0/+50
4000-12	+0/+4000	IP65	12	20000	+0/+10	+0/+50

Wiring Diagram

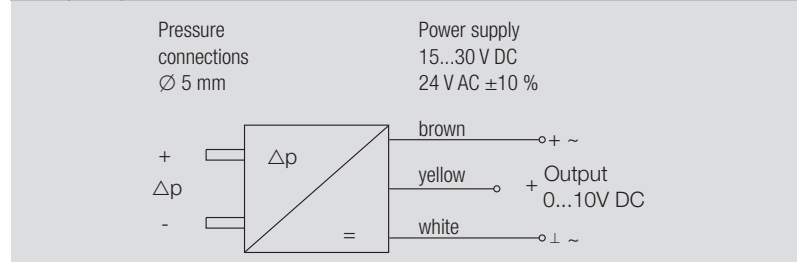

Accessories

Isolator ESH 21



Isolator ESH 21 (≤ 3kW)

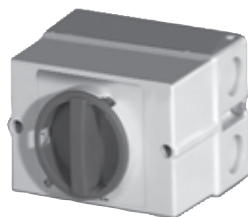

Isolator ESH 21 (≥ 5.5kW)

Design

Beautifully shaped, shock-resistant plastic casing. Protection class IP44/IP65, for sur-face mounting, switching symbols 0 and I. The isolator is fitted with connection terminals that are very accessible and has a con-nection diagram glued in the casing.

The **ESH21 up to 3kW** is designed to IP44. It is equipped with an integrated lo-cking mechanism.

The **ESH21 up to 5.5kW** is designed to IP65. It is equipped with a coupling cover and an integrated locking mechanism. A padlock can in some cases be fitted to the rotary switch.

Function

The isolator disconnects the fan safely from the mains in the event of cleaning, maintenance or repair work on site and thus avoids accidents due to uncontrolled activation of the unit by third parties. It is no main switch or emergency switch.

All of the classified isolators are fitted with potential-free contacts (1 closer and 1 opener).

The isolators for motors with a built-in thermal contact have on principle three supplementary auxiliary contacts, so that the pre-switched control device does not drop out during cleaning or servicing work due to motor.

Caution about combination with frequency inverter!

Special EMC-action can be necessary, furthermore do not switch during operation, overvoltages can destroy the switch and the motor-winding.

The isolators are grouped according to motor rated power. All important characteristic data are evident from the model designation.

E.g.: **ESH 21-0030-65** = 3kW switch - 6 main contacts - 5 auxiliary contacts

Technical Data | Dimensions

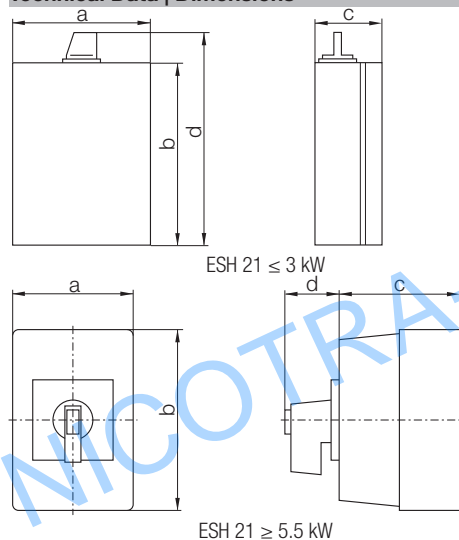

ESH 21-	Permissible motor power kW	a mm	b mm	c mm	d
0030-22	3	73	108	45	
0030-25	3	73	108	45	
0030-32	3	73	108	45	
0030-35	3	73	108	45	
0030-62	3	73	108	45	
0030-65	3	73	108	45	
0055-32	5.5	85	120	80	110
0055-65	5.5	125	125	126	157
0075-32	7.5	85	120	80	110
0075-35	7.5	85	120	80	110
0075-62	7.5	100	190	91	133
0075-95	7.5	125	125	126	157
0110-32	11	85	160	80	110
0110-62	11	100	190	91	133
0150-32	15	100	190	91	120
0150-62	15	145	250	100	145
0220-32	22	100	190	91	120
0220-62	22	145	250	100	145
0300-32	30	145	250	100	140
0300-62	30	200	300	172	200
0370-32	37	145	250	100	140
0370-62	37	200	300	172	200
0450-32	45	200	300	172	200
0450-62	45	300	300	172	210
0550-32	55	200	300	172	200
0550-62	55	300	300	172	210
0900-32	90	280	400	180	210
0900-62	90	280	280	260	327

Accessories

Isolator ESH 22

Design

Shock-resistant metal casing, black switch with symbols 0 and I. Protection class IP65 or IP54, for surface mounting (see determination in the tabular).

The isolator is fitted with connection terminals that are very accessible and has a connection diagram glued in the casing.

All isolators are equipped with a coupling cover and an integrated locking mechanism. In some cases a padlock can be fitted to the rotary switch.

Function

The isolator disconnects the fan safely from the mains in the event of cleaning, maintenance or repair work on site and thus avoids accidents due to uncontrolled activation of the unit by third parties. It is no main switch or emergency switch.

All of the classified isolators are fitted with potential-free contacts (1 closer and 1 opener).

The isolators for motors with a built-in thermal contact have on principle three supplementary auxiliary contacts, so that the preswitched control device does not drop out during cleaning or servicing work due to motor.

Use

The isolator ESH22 with metal casing is necessary, if screened components must be used. (e.g. frequency inverters or control engineering devices are used featuring electronic components).

Attention!

Do not switch during operation, overvoltages can destroy the switch and the motor winding!

The isolators are grouped according to motor rated power. All important characteristic data are evident from the model designation.

E.g.: **ESH 22-0075-65** = 7.5kW switch, 6 main contacts, 5 auxiliary contacts.

Technical Data | Dimensions

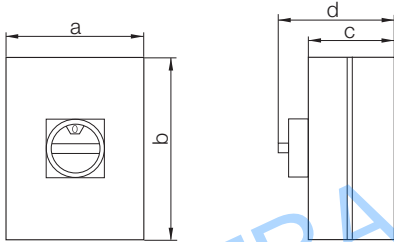

ESH 22-	Permissible motor power kW	a mm	b mm	c mm	d mm	Cable lead-through (top)	Cable lead-through (bottom)
0075-32	7.5	122	120	120	120	2×PG21	2×PG21
0110-32	11	122	120	120	120	2×PG21	2×PG21
0150-32	15	180	180	130	130	2×PG21	2×PG21
0220-32	22	180	180	130	130	2×PG21	2×PG21
0300-32	30	230	280	150	150	2×PG29/1×PG16	2×PG29
0370-32	37	230	280	150	150	2×PG36/1×PG16	2×PG36
0075-62	7.5	180	180	130	130	1×PG29/1×PG16	2×PG29
0110-62	11	180	180	130	130	1×PG36/1×PG16	2×PG36
0150-62	15	230	280	150	150	2×PG36/1×PG16	2×PG36
0220-62	22	230	280	150	150	2×PG36/1×PG16	2×PG36
0300-62	30	230	280	150	150	2×PG36/1×PG16	2×PG36
0370-62	37	230	280	150	150	2×PG36/1×PG16	2×PG36
0055-35	5.5	180	180	100	100	2×PG21	2×PG21
0075-65	7.5	116	95	80	80	2×PG16	2×PG16
0075-95	7.5	116	95	80	80	2×PG16	2×PG16

Notes

Quality management system

DIN EN ISO 9001

Nicotra Gebhardt quality is the result of a continuous company policy intended to guarantee that our product properties and features are clearly superior to comparable products.

This already established company maxim led in April 1985 to the auditing and certification of the existing quality management system. In the following years it was updated to match the changing international and European standards. Modern production processes, monitored by our quality management system, guarantee a high repeat accuracy in production.

This ongoing high standard of quality permits the establishing of the performance data in classes of accuracy in accordance with DIN 24166.

The narrow tolerances ensure a high level of data reliability for our products.

Machine Safety

The fans contained in this catalogue are not machines in the sense of the EC Machine Directive. They are delivered with a manufacturer "Declaration of incorporation".

The assessment of the dangers associated with the fan and necessary safety measures are based on the VDMA Unit sheet 24167 : Fans; Safety requirements.

The operating instructions give which safety measures are still necessary on assembly to ensure that the fans comply with the Machine Directive 2006/42/EC.

Catalogue data

We reserve the right to change any measurements and technical data in this catalogue in accordance with further development of our products. All information valid at the time of printing.

NICOTRA-GEBHARDT-FAN.RU

NICOTRA-GEBHARDT-FAN.RU

Nicotra Gebhardt worldwide

SPAIN

Ctra. Alcalá-Villar del Olmo, Km. 2,830
28810 Villalbilla-Madrid
Phone +34 918-846110
Fax +34 918-859450
E-mail info@nicotra.es

c/.Coso, 67-75, esc. 1.a,1.oB
50001 Zaragoza
Phone +34 976-290550
Fax +34 976-298127
E-mail gebhardt@teleline.es

BELGIUM

Haeghensgoed, 13 - 00/01
9270 Laarne
Phone +32 (0)9-336-00-01
Fax +32 (0)9-336-00-05
E-mail info.nicotra@nicotra.be

FRANCE

Leader's Park Bat A1
3 chemin des Cytises
69340 Francheville
Phone +33 (0)4 72 79 01 20
Fax +33 (0)4 72 79 01 21
E-mail g.cauche@nicotra-gebhardt.com

SWEDEN

Box 237
Kraketorpsgatan 30
43123 Mölndal
Phone 0046 31-874540
Fax 0046 31-878590
E-mail info.se@nicotra-gebhardt.com

GREAT BRITAIN

Unit D, Rail Mill Way
Parkgate Business Park
Rotherham
South Yorkshire
S62 6JQ
Phone +044 01709-780760
Fax +044 01709-780762
E-mail sales@nicotra.co.uk

UNITED STATES

PO BOX 900921
Sandy, Utah 84090
Phone 001(801) 733-0248
Fax 001(801) 315-9400
Mobile 001(801) 682 0898
E-mail mike.sehgal@gebhardtfans.com
<http://www.gebhardtfans.com/>



MALAYSIA

Lot 1799, Jalan Balakong
Taman Perindustrian Bukit Belimbing
43300 Seri Kembangan
Selangor
Phone +603 8961-2588
Fax +603 8961-8337
E-mail info_malaysia@nicotra-gebhardt.com

THAILAND

6/29 Soi Suksawadi 2, Moo 4, Suksawadi Road,
Kwang Jomthong, Khet Jomthong,
Bangkok 10150
Phone +662 476-1823-6
Fax +662 476-1827
E-mail sales@nicotra.co.th

SINGAPORE

3, Science Park Drive, # 04-07, The Franklin
Singapore Science Park 1
Singapore 118223
Phone +65 6265 1522
Fax +65 6265 2400
E-mail info_singapore@nicotra-gebhardt.com

AUSTRALIA

65 Yale Drive,
Epping, VIC 3076
Phone +61 3 9017 5333
Fax +61 3 8401 3969
E-mail info@nicotra.com.au

INDIA

Plot no 28F & 29, Sector-31, Kasna,
Greater Noida-201 308 U.P (India)
Phone +91 120 4783400
Phone +91 22 65702056 (Mumbai)
Phone +91 80 25727830 (Bangalore)
E-mail info@nicotraindia.com

CHINA

88 Tai'An Road, XinQiao, ShiJi, Panyu
Guangzhou 511450
PR CHINA
Phone +86 (0)20-39960570
Fax +86 (0)20-39960569
E-mail sales@nicotra-china.com

Nicotra Gebhardt Germany

Nicotra Gebhardt GmbH
Gebhardtstraße 19-25
74638 Waldenburg
Germany
Phone +49 (0)7942 101 0
Fax +49 (0)7942 101 170
E-Mail info@nicotra-gebhardt.com

Nicotra Gebhardt Italy

Nicotra Gebhardt S.p.A
Via Modena, 18
24040 Zingonia (BG)
Italy
Phone +39 035 873 111
Fax +39 035 884 319
E-Mail info@nicotra-gebhardt.com

nicotra-gebhardt.com