



## Enclosures & Components

### Unibox 14

#### System Solutions

Integrated Systems Chassis Platforms Backplanes Embedded Products Cabinets

#### Enclosures & Components

Enclosures Front Panels Handles

#### Rotary Switches

Switches/Encoders Knobs LEDs

# 1: Unibox 14

B

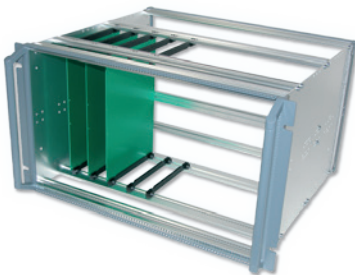
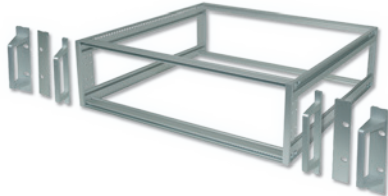

## 1.1 Unibox 14 Overview

B | 1\_3

1.1.1 Complete Unibox 14 Kits

B | 1\_4

## 1.2 Frame for Unibox 14

B | 1\_7

1.2.1 Width

B | 1\_7

1.2.2 Height

B | 1\_7

1.2.3 Depth

B | 1\_8

## 1.3 Cover Panel for Unibox 14

B | 1\_9

1.3.1 Top Cover Panel

B | 1\_9

1.3.2 Bottom Cover Panel with Attached Feet

B | 1\_10

1.3.3 Side Panels

B | 1\_10

1.3.4 Drawing

B | 1\_11

## 1.4 Adaptation Kits

B | 1\_12

1.4.1 Adaptation Kit a

B | 1\_12

1.4.2 Adaptation Kit b

B | 1\_13

1.4.3 Additional Extrusions Recessed Card Mounting

B | 1\_13

1.4.4 Tapped Strips

B | 1\_14

1.4.5 Edge Connector Extrusion 66-145-xx

B | 1\_14

1.4.6 Edge Connector Extrusion 66-147-xx

B | 1\_14

## 1.5 Assembly Accessories

B | 1\_15

1.5.1 Horizontal Card Mounting Kit

B | 1\_15



<b>1.6 General Accessories</b>	<b>B   1_16</b>
1.6.1 Perforated Cover Plates	B   1_16
1.6.2 Mounting Chassis	B   1_17
1.6.3 Earthing Set	B   1_19
1.6.4 Card Guides IEC	B   1_20
1.6.5 Flat Front Panels	B   1_22
1.6.6 Fan Front Panel 84 HP for Vertical Ventilation	B   1_23
1.6.7 Fan Front Panel for Horizontal Ventilation	B   1_24
1.6.8 Fan Front Panels for Direct Fan Mounting	B   1_24
1.6.9 Top / Bottom-Hinged Front Panel	B   1_25
1.6.10 Side-Hinged Front Panel	B   1_26
1.6.11 Extruded Front Panels	B   1_27
1.6.12 Front Panel with Cutout for IEC Ejector Handle	B   1_29
1.6.13 Card Locks and Card Handles	B   1_30
1.6.14 Card Holder acc. to IEC Standard	B   1_32
1.6.15 Middle Part	B   1_33
1.6.16 Protective Cover for 6 U Printed Board	B   1_33
1.6.17 Spacers	B   1_34
1.6.18 Mounting Plates	B   1_35
1.6.19 Hexagonal Spacers M3 Thread	B   1_35
1.6.20 Covering Caps	B   1_35
1.6.21 Mounting Bracket	B   1_36

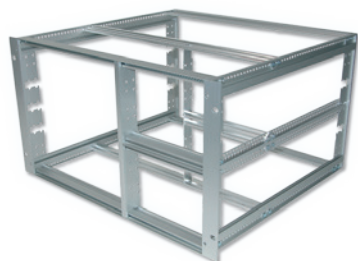

<b>1.7 Extrusions</b>	<b>B   1_37</b>
1.7.1 Front Extrusions	B   1_37
1.7.2 Height Extrusions	B   1_38
1.7.3 Depth Extrusions	B   1_39
1.7.4 Internal Extrusions	B   1_40
1.7.5 Edge Connector Extrusions	B   1_42

# 1: Unibox 14



## 1.1 Unibox 14 Overview

- Usable as sub rack or as desktop case
- Card mounting from front and back
- Dimensions according to IEC 60297
- Numerous adaptation options
- The extruded aluminium frame can be used as a sub rack or, when clad with a set of easily fitted cover plates, transformed into a small table-top instrument case
- Rack mount complete with cover plates possible
- Panels and modules can be mounted from the front or the back
- Adaptation kits available for mounting modules
- Fitting of telescopic rails or guide rails only possible for 81 HP (upon request only)
- Can be employed as a desktop case or sub rack for mounting in 19" cabinets
- In either configuration it will accept PCBs and plug-in units based on standard card sizes conforming to DIN 41494 or IEC 60297
- Recessed mounting with a pitch of 7.5 mm is possible
- With metal cover plates fitted, the sub rack is suitable for use where it is subjected to continuous vibration

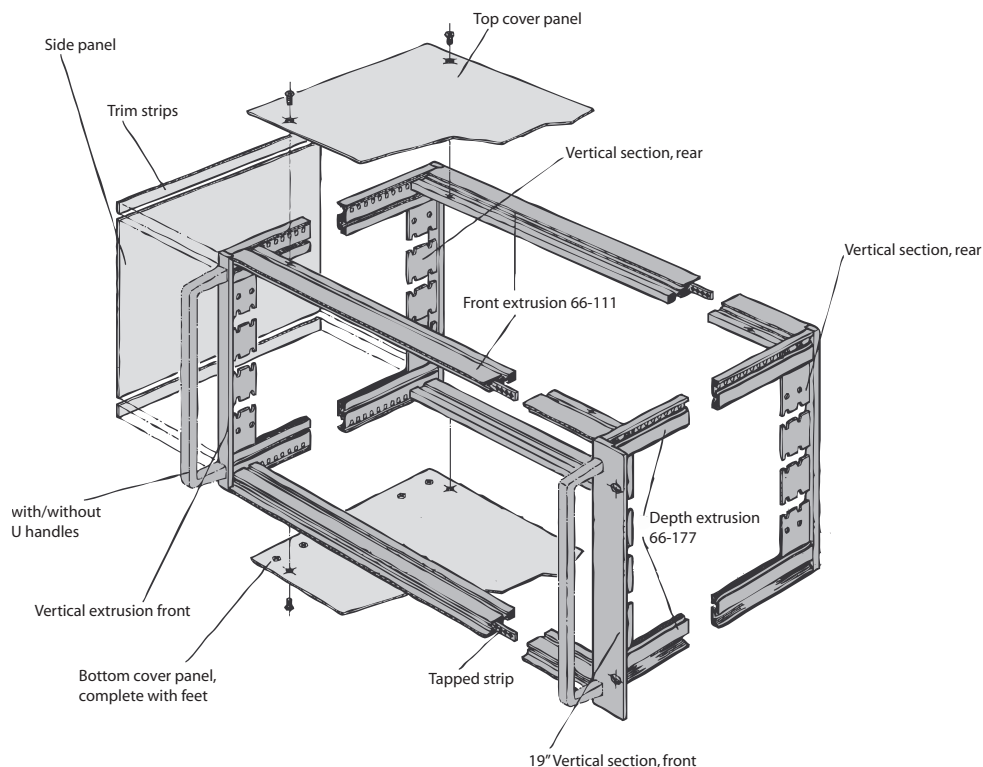

# 1: Unibox 14

## 1.1.1 Complete Unibox 14 Kits

You can find the most used complete kits below.

With the new order structure (see "Configuration" B|1\_6) you have however the possibility of configure your individual housing in different steps. Use this offer or contact us for further information or any other help.

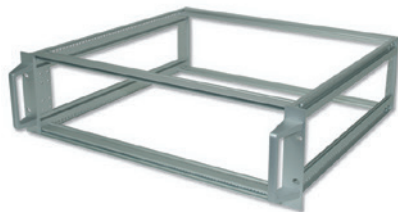

### 1.1.1.1 Unibox 14 Frame Kit

- **Scope of delivery:**
  - 2 front height extrusions (detail see 1.2.2)
  - 2 rear height extrusions (detail see 1.2.2)
  - 4 front/rear extrusions (detail see 1.2.1)
  - 4 depth extrusions (detail see 1.2.3)
  - 2 handles 9mm (detail see 1.2.2)
  - 1 label strip (detail see 1.2.1)
  - 1 set assembly material
- Tapped strips have to be ordered separately, see below
- Front / rear panel have to be ordered separately, see 1.6.5
- Cover panels have to be ordered separately, see below or 1.3

#### Frame without 19" vertical sections, with handles

Height	Width	Depth			
		232.6 mm 9.15"	292.6 mm 11.51"	412.6 mm 16.24"	532.6 mm 20.96"
2 U	42 HP	14B522	-	-	-
	84 HP	-	14B123	14B125	-
3 U	42 HP	14B532	14B533	-	-
	63 HP	14B432	14B433	-	-
	84 HP	-	14B133	14B135	14B137
4 U	84 HP	-	14B143	14B145	14B147
6 U	84 HP	-	14B163	14B165	-

#### Frame with 19" vertical sections, with handles

Height	Width	Depth			
		232.6 mm 9.15"	292.6 mm 11.51"	412.6 mm 16.24"	532.6 mm 20.96"
2 U	84 HP	14B022	14B023	14B025	-
3 U	84 HP	14B032	14B033	14B035	14B037
4 U	84 HP	14B042	14B043	14B045	14B047
6 U	84 HP	14B062	14B063	14B065	14B067
7 U	84 HP	-	-	14B075	14B077

### 1.1.1.2 Tapped Strips

- Steel, zinc-plated
- **Scope of delivery:**
  - 1 tapped strip

Size	42 HP	63 HP	84 HP
M2.5 / 2 x 6 mm	01-464	61-469	61-468

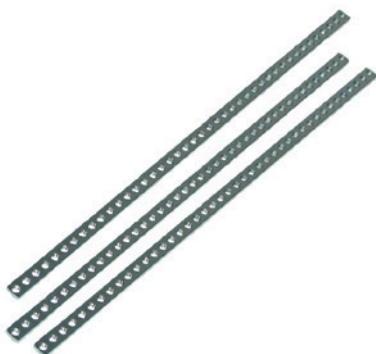

# 1: Unibox 14

## 1.1.1.3 Unibox 14 Cover panel Kit

### • Scope of delivery:

- 1 top cover panel, solid, light grey (detail see 1.3.1)
- 1 bottom cover panel with feet, solid, light grey (detail see 1.3.2)
- 2 side panels, solid, light grey (detail see 1.3.3)
- 1 set of trim strips (detail see 1.3.3.1)
- 1 set of rubber bands (detail see 1.3.3.2)
- 1 set assembly material



Height	Width	Depth			
		232.6 mm 9.15"	292.6 mm 11.51"	412.6 mm 16.24"	532.6 mm 20.96"
2 U	42 HP	14Z422-10	-	-	-
	84 HP	-	14Z123-10	14Z125-10	-
3 U	42 HP	14Z432-10	14Z433-10	-	-
	84 HP	-	14Z133-10	14Z135-10	14Z137-10
4 U	84 HP	-	14Z143-10	14Z145-10	14Z147-10
6 U	84 HP	14Z162-10	14Z163-10	14Z165-10	-
7 U	84 HP	-	-	14Z175-10	14Z177-10

## Configuration

**Frame**

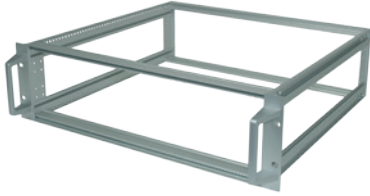

**Width  
1.2.1**

- 42 HP / 63 HP / 84 HP  
(incl. assembly material)

**1.2.1.2 Label Strips**

**Height  
1.2.2**

- 2 U / 3 U / 4 U / 6 U / 7 U
- slim/19"
- with/without holes for handles

**1.2.2.1 Handles**

**Depth  
1.2.3**

- 232.6 mm, 292.6 mm,  
532.6 mm, 412.6 mm

**Covers**

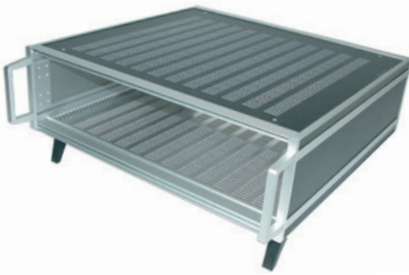

**Top Cover  
1.3.1**

- light grey or black
- solid/perforated
- width 42 HP, 63 HP, 84 HP
- formed for backplane mounting

**Assembly Material**

- for top cover

**Bottom Cover  
1.3.2**

- light grey or black
- solid/perforated
- width 42 HP, 63 HP, 84 HP
- formed for backplane mounting

**Assembly Material**

- for bottom cover

**Side Panels  
2.2.6 / 2.3.6**

- light grey or black
- solid/perforated
- height 2 U, 3 U, 4 U, 6 U, 7 U
- depth 232.6 mm, 292.6 mm,  
412.6 mm, 532.1 mm

**Trim Strip  
1.3.3.1**

- colour: light grey or black
- depth: 232.6 mm, 292.6 mm,  
412.6 mm, 532.6 mm

**Assembly Material  
1.3.3.2**

- for side panels and trim strips

**1.4 Adaptation Kits**

**1.5 Assembly Accessories**

**1.6 General Accessories**

**1.7 Extrusions**

# 1: Unibox 14

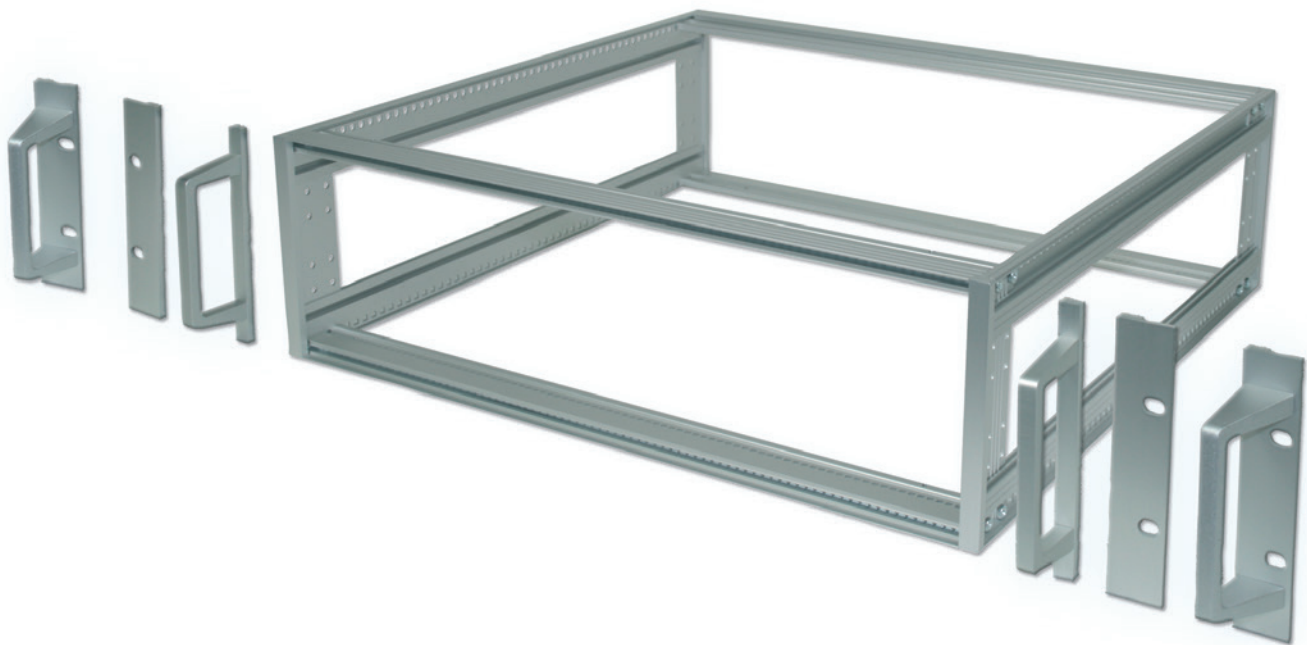

## 1.2 Frame for Unibox 14

- Usable as sub rack
- Different possibilities of card mounting
- Dimensions according to IEC 60297



### 1.2.1 Width

- **Scope of delivery:**
  - 4 front/rear extrusions
  - 4 tapped strips M2.5
  - Assembly material: 1 set of screws cross recessed M4x10 (63-109)

42 HP	63 HP	84 HP
14M001	14M002	14M003

### Label Strips

- **Scope of delivery:**
  - 1 label strip consisting of 4 single tapes

Scope of Delivery	42 HP (01-42/42-01)	63 HP (01-63/63-01)	84 HP (01-84/84-01)
2 pcs. each (upper and lower)	63-142	63-143	63-046

### 1.2.2 Height

- **Scope of delivery:**
  - 2 height extrusions
- 2 sets have to be ordered (for front and rear)

Description	2 U	3 U	4 U	6 U	7 U
Slim without holes for handle	14M004	14M005	14M006	14M007	14M008
Slim with holes for handle	14M009	14M010	14M011	14M012	14M013
19" section without holes for handle	14M014	14M015	14M016	14M017	14M018
19" section with holes for handle	14M019	14M020	14M021	14M022	14M023

#### 1.2.2.1 Handles

- **Scope of delivery:**
  - 1 handle
- 2 handles have to be ordered per case
- 2 screws per handle have to be ordered separately

Description	2 U	3 U	4 U	6 U	7 U
9 mm	60-527	60-528	60-529	60-531	60-529
Universal handle (for 19" section only)		60-553	60-554	60-556	60-554

Screws cross sloted countersunk M4 x 10	5342-10
---	---------





# 1: Unibox 14

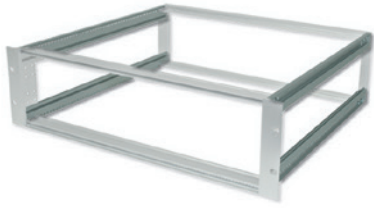

## 1.2.3 Depth

- **Scope of delivery:**
  - 4 depth extrusions

<b>232.6 mm</b> <b>9.15"</b>	<b>292.6 mm</b> <b>9.15"</b>	<b>412.6 mm</b> <b>16.24"</b>	<b>532.6 mm</b> <b>20.96"</b>
14M024	14M025	14M026	14M027

## Line drawings for sub rack without 19" vertical sections

Plan view

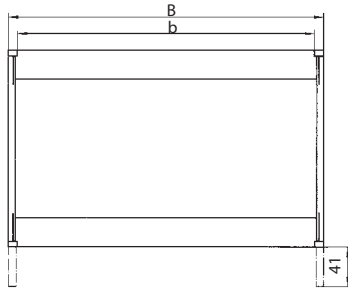

Side view section

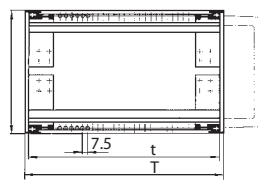

Front view

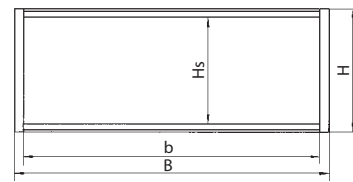

### Heights

for	H mm	H inch	Hs mm	Hs inch
2 U	88.05	3.46	68.05	2.67
3 U	132.50	5.21	112.50	4.42
4 U	176.95	6.96	156.95	6.17
6 U	265.85	10.46	245.85	9.67
7 U	310.30	12.21	290.30	11.42

### Depths

T mm	T inch	t mm	t inch
244.6	9.62	232.6	9.15
304.6	11.99	292.6	11.51
424.6	16.71	412.6	16.24
544.6	21.44	532.6	20.96

### Width

for	B mm	B inch	b mm	b inch
42 HP	234.32	9.22	213.32	8.39
63 HP	341.00	13.42	320.00	12.59
84 HP	447.68	17.62	426.68	16.79

## Line drawings for sub rack with 19" vertical sections

Plan view

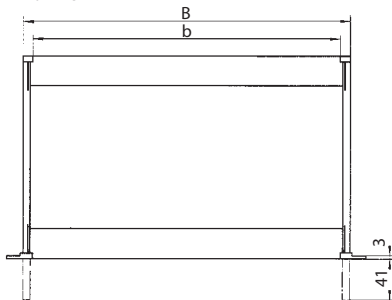

Side view section

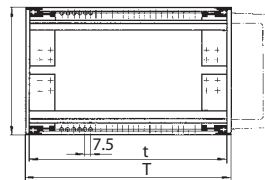

Front view

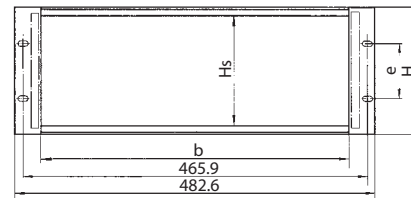

### Heights

for	H mm	H inch	Hs mm	H inch
2 U	88.05	3.46	68.05	2.67
3 U	132.50	5.21	112.50	4.42
4 U	176.95	6.96	156.95	6.17
6 U	265.85	10.46	245.85	9.67
7 U	310.30	12.21	290.30	11.42

### Depths

T mm	T inch	t mm	t inch
244.6	9.62	232.6	9.15
304.6	11.99	292.6	11.51
424.6	16.71	412.6	16.24
544.6	21.44	532.6	20.96

### Width

for	B mm	B inch	b mm	b inch
84 HP	447.68	17.62	426.68	16.79

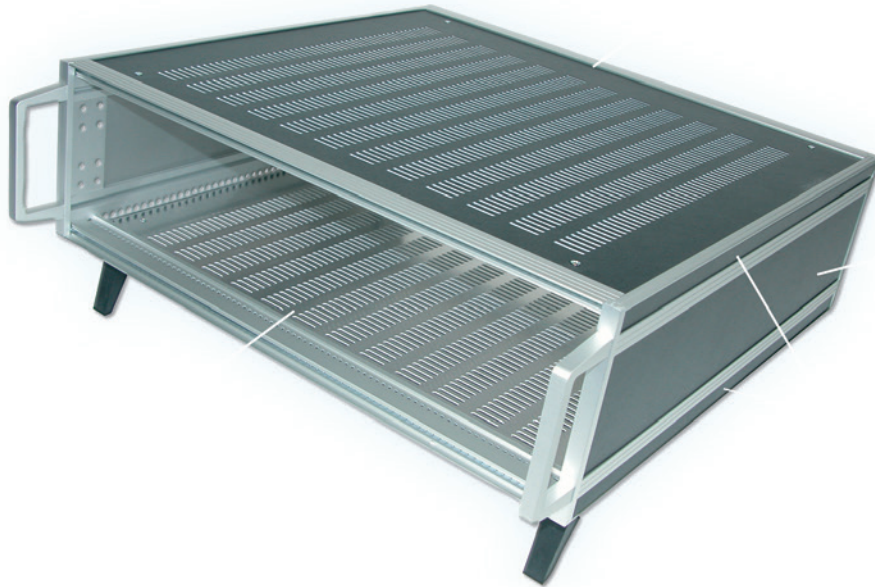

## 1.3 Cover Panel for Unibox 14

- One sided film laminated sheet aluminium 1.5 mm
- Perforated top and bottom covers are available for better ventilation
- Bottom cover plates are supplied with feet attached
- Sub rack can be mounted complete with cover plates in a cabinet
- Formed top and bottom cover panels available for 84 HP for accomodation of backplane (drawing see 1.3.4.1)

### 1.3.1 Top Cover Panel

- **Scope of delivery:**
  - 1 top cover panel

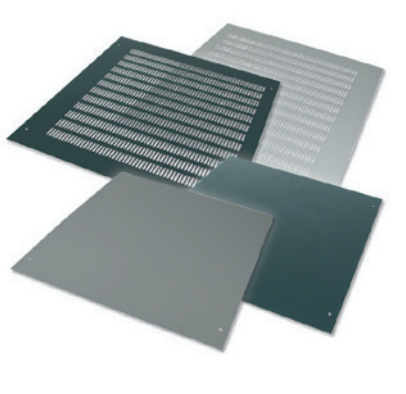

Description	Depth Width	232.6mm 9.15"	292.6mm 11.51"	412.6mm 16.24"	532.6mm 20.96"
Solid, light grey	42 HP	14-817-10	14-818-10	14-820-10	—
Perforated, light grey		14-817-11	14-818-11	14-820-11	—
Solid, light grey	63 HP	14-812-10	14-813-10	14-815-10	—
Perforated, light grey		14-812-11	14-813-11	14-815-11	—
Solid, light grey	84 HP	14-802-10	14-803-10	14-805-10	—
Perforated, light grey		14-802-11	14-803-11	14-805-11	14-828-11
Solid, light grey, formed		—	14-702-10	14-704-10	14-706-10
Perforated, light grey, formed		—	14-702-11	14-704-11	14-706-11

Black versions available on request.

### Assembly Material

- For mounting 1 top and 1 bottom cover onto the frame

Description	Part-No.
1 set of cross recessed screws	63-111
1 set of cross recessed screws for cranked version	63-195

## 1.3.2 Bottom Cover Panel with Attached Feet

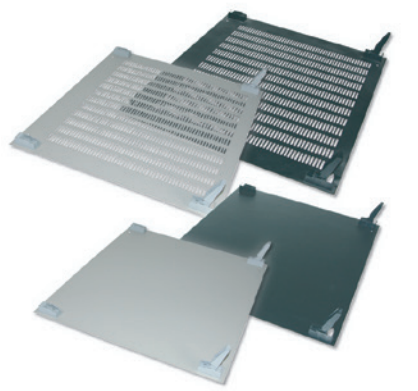

### 1.3.2 Bottom Cover Panel with Attached Feet

- **Scope of delivery:**
  - 1 bottom cover panel

Description	Depth Width	232.6mm 9.15"	292.6mm 11.51"	412.6mm 16.24"	532.6mm 20.96"
Solid, light grey	42 HP	14-867-10	14-868-10	14-870-10	—
Perforated, light grey		14-867-11	14-868-11	14-870-11	—
Solid, light grey	63 HP	14-862-10	14-863-10	14-865-10	—
Perforated, light grey		14-862-11	14-863-11	14-865-11	—
Solid, light grey	84 HP	14-852-10	14-853-10	14-855-10	—
Perforated, light grey		14-852-11	14-853-11	14-855-11	14-848-11
Solid, light grey, formed		—	14-766-10	14-768-10	14-770-10
Perforated, light grey, formed		—	14-766-11	14-768-11	14-770-11

Black versions available on request.

### Assembly Material

- For mounting 1 top and 1 bottom cover onto the frame

Description	Part-No.
1 set of cross recessed screws	63-111
1 set of cross recessed screws for cranked version	63-195

## 1.3.3 Side Panels

- **Scope of delivery:**
  - 1 side panel
- 2 pieces have to be ordered (for left and right side)
- Trim strips see 1.3.3.1
- Assembly material see 1.3.3.2

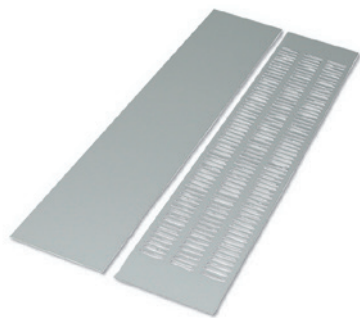

### 1.3.3 Side Panels

Description	Height Depth	2 U	3 U	4 U	6 U	7 U
Solid, light grey	232.6 9.15"	30-902-1	30-907-1	30-912-1	30-922-1	—
Solid, light grey	292.6	30-903-1	30-908-1	30-913-1	30-923-1	30-962-1
Perforated, light grey	11.51"	—	14-783-1	14-793-1	—	—
Solid, light grey	412.6	30-905-1	30-910-1	30-915-1	30-925-1	14-603-10*
Perforated, light grey	16.24"	14-754-1	14-785-1	14-795-1	14-761-1	—
Solid, light grey	532.6	—	30-988-1	30-989-1	30-991-1	14-613-10*
Perforated, light grey	20.96"	—	14-787-1	—	—	—

\*Assembly material for mounting 2 side panels 7 U, depth: 412.6/532.6 mm: 63-195  
Black versions available on request.

### 1.3.3.1 Trim Strips

- **Scope of delivery:**
  - 4 trim strips

Description	Depth	232.6 mm 9.15"	292.6 mm 11.51"	412.6 16.24"	532.6 20.96"
Solid, light grey		30-932-1	30-933-1	30-935-1	30-944-1

Black versions available on request.

### 1.3.3.2 Assembly Material for Side Panels and Trim Strips

Description	Depth mm	Depth inch	Part-No.
1 set of rubber tubing	232.6	9.15	63-096
1 set of rubber tubing	292.6	11.51	63-097
1 set of rubber tubing	412.6	16.24	63-099
1 set of rubber tubing	532.6	20.96	63-141



# 1: Unibox 14

## 1.3.4 Drawing

### 1.3.4.1 Line Drawing Cover Panel Formed for Accomodation of Backplane

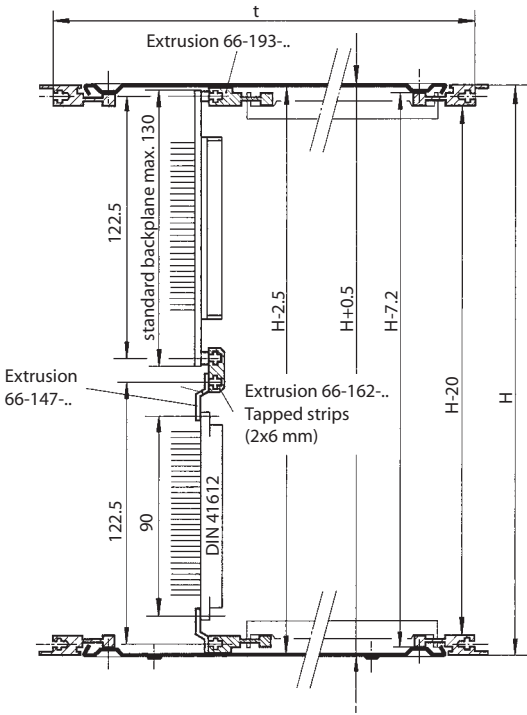

for	H	
	mm	inch
3 U	132.50	5.21
4 U	176.95	6.96
6 U	265.85	8.71
7 U	310.30	10.46

### 1.3.4.2 Line Drawing of Side Panel for Crossflow Ventilation

Side panel 2U

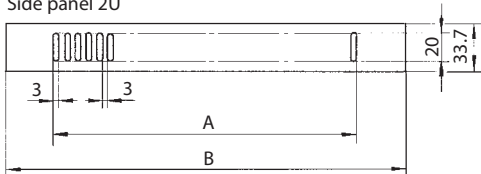

Case Depth t	A		B		
	mm	inch	mm	inch	
292.6	11.51	225	8.85	292.3	11.50
412.6	16.24	345	13.58	412.3	16.23
532.6	20.96	465	18.30	532.3	20.95

Side panel 3 U

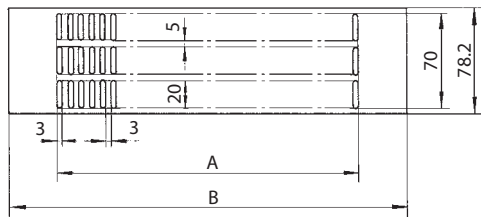

Side panel 4 U

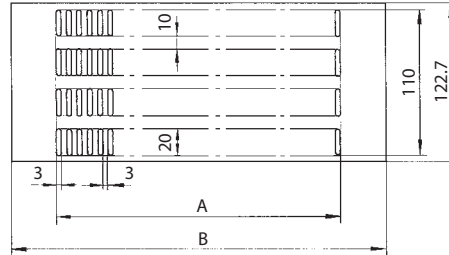

Side panel 6 U

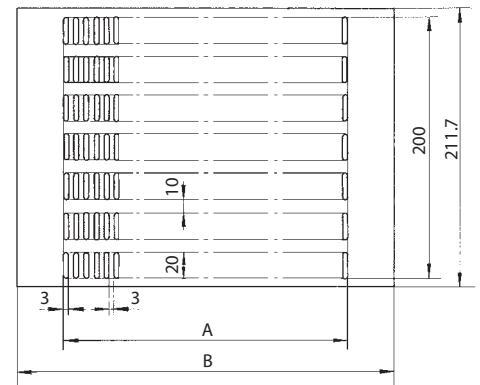

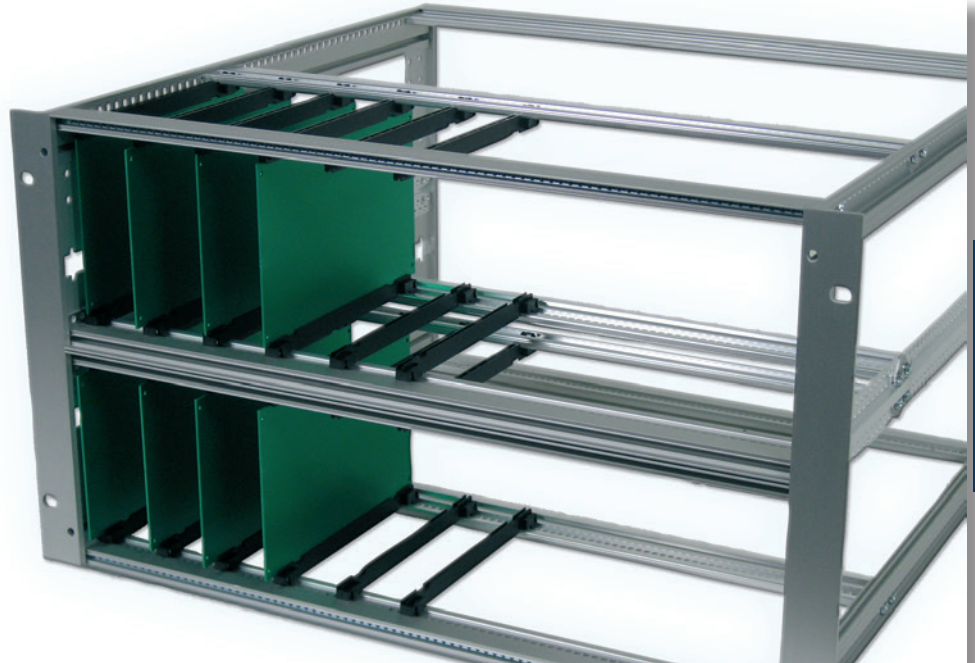

## 1.4 Adaptation Kits

- Adaptation kits are used to subdivide the basic frame both in depth and height
- Tapped strips have to be ordered separately, see 1.4.7

### Note:

#### Information for Adaptation kits a - e:

- 14-xxx-  for mounting:
  - **0** = standard extrusions, 66-144/66-124  
(when supplementary edge connector extrusions are also used, see 1.4.8)
  - **6** = backplane mounting 66-193  
(insulating strips see 1.7.4.3)
- Scope of delivery is shown in blue in the following illustrations
- Tapped strip see 1.4.7

### 1.4.1 Adaptation Kit a

- **Range of Application:**
  - Single eurocard depth 160 – 400 mm
  - Connector to IEC 60603-2/DIN 41617/MIL-C-21097
  - Motherboard
  - Modules, cassettes, plug-in units
  - Set for horizontal mounting of single, double triple eurocards, depth 160 + 400 mm
  - Crossflow ventilation with 3 U fan module
  - Drive mechanism receptacles 3<sup>1</sup>/<sub>2</sub>"/5<sup>1</sup>/<sub>4</sub>"

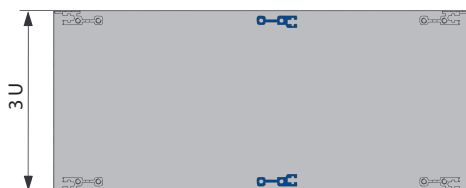

#### 1.4.1 Adaptation Kit a

- **Scope of delivery:**
  - 2 internal extrusions
  - 1 set assembly material

Description	84 HP
Front-mounting of single eurocards	14-910-0
	14-910-6

Other widths available on request.

# 1: Unibox 14

## 1.4.2 Adaptation Kit b

- **Range of Application:**

- Single eurocards, depth 160 – 400 mm
- Connector to IEC 60603-2
- Motherboard
- Modules, cassettes, plug-in units
- Vertical ventilation with 1 U fan module
- Set for horizontal mounting of single, double, triple eurocards, depth 160 – 400 mm
- Crossflow ventilation with 3 U fan module
- Drive mechanism receptacles 3 1/2" / 5 1/4"



### 1.4.2 Adaptation Kit b

- **Scope of delivery:**

- 3 internal extrusions
- 1 front extrusion
- 2 depth dividers
- 1 set assembly material

Description	Depth		84 HP
	mm	inch	
Front-mounting of single eurocards in a 4 U case with possibility of crossflow ventilation	292.6	11.51	14-913-65
	412.6	16.24	14-915-65

## 1.4.3 Additional Extrusions Recessed Card Mounting

- For recessed mounting of Eurocards without individual front panels
- **Scope of delivery:**
  - 2 internal extrusions
  - 1 set assembly material
- For recessed card mounting two sets are necessary

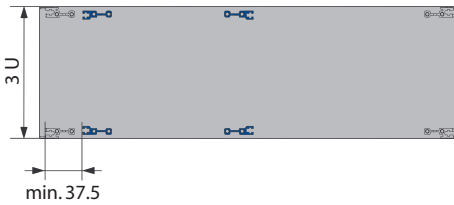

### 1.4.3 Additional Extrusions Recessed Card Mounting

Description	84 HP
For frame width	14-910-0

## 1.4.4 Tapped Strips

- Steel, zinc-plated
- **Scope of delivery:**
  - 1 tapped strip



### 1.4.7.1 Tapped Strips for Use with Extrusion 66-144, 66-124

Size	42 HP	63 HP	84 HP
M2.5 / 2 x 6 mm	61-464	61-469	61-468

### 1.4.7.2 Tapped Strips for Use with Extrusion 66-193

Size	42 HP	63 HP	84 HP
M2.5 / 1.8 x 5 mm	61-471	61-472	61-474

## 1.4.5 Edge Connector Extrusion 66-145-xx

- For use with standard extrusion 66-144
- **Scope of delivery:**
  - 1 aluminium extrusion, clear passivated (conductive)

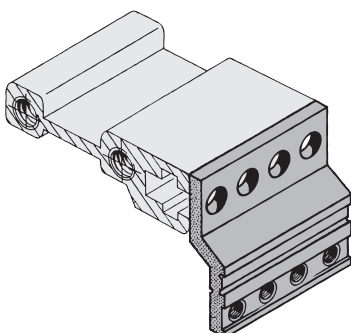

### 1.4.8 Supplementary Edge Connector Extrusion

Description	8 HP	18 HP	28 HP	42 HP	63 HP	84 HP
For edge connector, IEC 60603-2	66-145-40	66-145-41	66-145-42	66-145-63	66-145-65	66-145-52

#### 1.4.8.1. Assembly Material

Description	Part-No.
Assembly material M2.5 (for 2 supplementary extrusions)	63-214

## 1.4.6 Edge Connector Extrusion 66-147-xx

- For use with extrusions for backplanes 66-193
- **Scope of delivery:**
  - 1 aluminium extrusion, clear passivated (conductive)

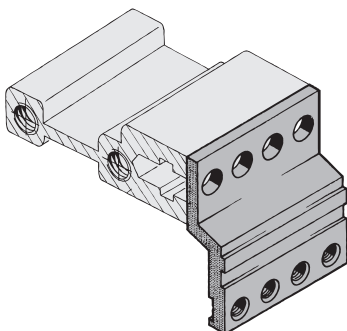

### 1.4.9 Edge Connector Extrusion

Description	8 HP	18 HP	28 HP	42 HP	63 HP	84 HP
For edge connector, IEC 60603-2	66-147-40	66-147-41	66-147-42	66-147-63	66-147-65	66-147-52

#### Assembly Material

Description	Part-No.
Assembly material M2.5 (for 2 supplementary extrusions)	63-214

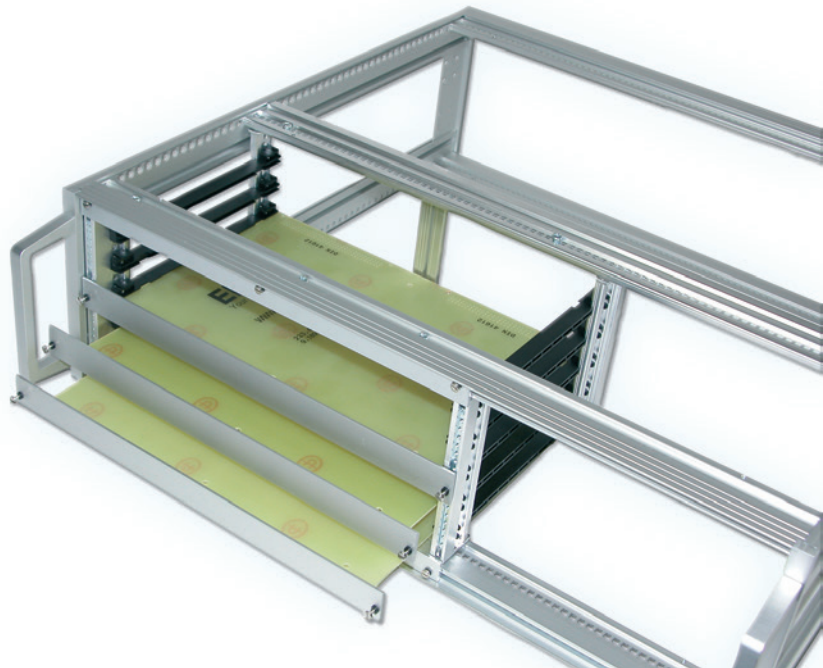

## 1.5 Assembly Accessories

### 1.5.1 Horizontal Card Mounting Kit

- For double eurocards (6 U)
- Independent of card depth
- The horizontal card mounting kit can be fitted recessed within the Unibox 14 by using two additional extrusions
- **Scope of delivery:**
  - 4 distance plates (2 front / 2 rear)
  - 4 length extrusions (2 front / 2 rear)
  - 1 centre extrusion
  - 6 tapped strips M2.5
  - 1 set assembly material
- Top and bottom cover plate when no overall fan front panel (1.5.2.1) is used
- Top and bottom cover plate has to be ordered separately (see table)
- Fan front panels for horizontal mounting kits see 1.5.2.1
- Card guides see 1.6.4
- Extruded front panels see 1.6.11

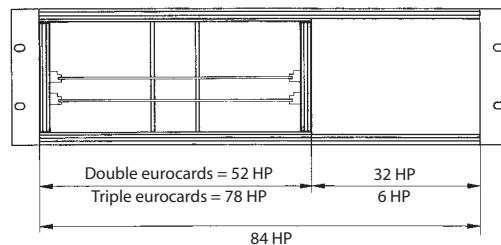

### 1.5.2 Horizontal Card Mounting Kit

Mounting Height	Usable Height	IEC 60603-2	Backplane	Cover plate top*	Cover plate bottom*
2 U	12 HP	-	14-961-60	21N604-90	21N605-90
3 U	20 HP	14-971-30	14-971-60	21N602-90	21N602-90
4 U	28 HP	-	14-981-60	21N602-90	21N603-90
6 U	48 HP	-	14-991-60	21N606-90	21N607-90

\* Assembly material for cover plate see 1.5.2.1





## 1.6 General Accessories

### 1.6.1 Perforated Cover Plates

- 1mm sheet aluminium, perforated
- Front extrusions and internal extrusions are pre-drilled to accept the fixing screws
- Provides mechanical protection for the card area
- **Scope of delivery:**
  - 1 perforated cover plate
- Assembly material see below
- Cover plates for card depths 300 mm and 400 mm upon request

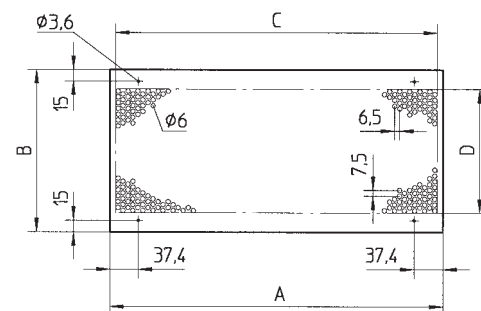

### 1.6.1 Perforated Cover Plates

Case Width	Card Depth	A	B	C	D	Part-No.
42 HP	160 mm 6.30"	217.64 mm 8.56"	149 mm 5.86"	207.5 mm 8.16"	107.25 mm 4.22"	11-701
	220 mm 8.66"	217.64 mm 8.56"	209 mm 8.22"	207.5 mm 8.16"	159.75 mm 6.28"	11-702
84 HP	160 mm 6.30"	431 mm 16.96"	149 mm 5.86"	415.5 mm 16.35"	107.25 mm 4.22"	11-706
	220 mm 8.66"	431 mm 16.96"	209 mm 8.22"	415.5 mm 16.35"	159.75 mm 6.28"	11-707
	280 mm 11.02"	431 mm 16.96"	269 mm 10.59"	415.5 mm 16.35"	212.25 mm 8.35"	11-708

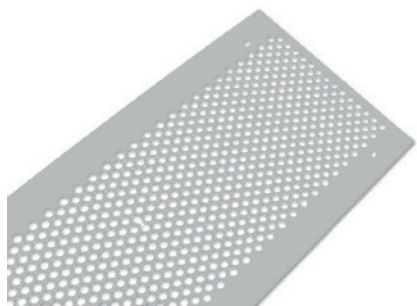

### Assembly Material

Description	Scope of Delivery	Part-No.
Cross recessed screw M3x6	Pack size 8 pieces	63-195
	1 piece	61-283



## 1.6.2 Mounting Chassis

### 1.6.2.1 Mounting Chassis Full Depth of Unibox 14

- For mounting non-standard modules and components
- Mounting chassis is fixed directly to the depth extrusion
- Aluminium 2.0 mm, raw
- **Scope of delivery:**
  - 1 mounting chassis
- Assembly material see below
- Mounting chassis depth < 230 mm can be mounted with 4 screws (> 230 mm with 6 screws)

### 1.6.2.1 Mounting Chassis Full Depth of Unibox 14

Frame Depth		Chassis Depth A		Part-No.		
mm	inch	mm	inch	42 HP	63 HP	84 HP
232.6	9.15	168	6.61	14M028	14M029	14M030
292.6	11.52	228	8.97	14M031	14M032	14M033
412.6	16.24	318	12.52	-	14M034	14M035
532.6	20.96	423	16.65	-	-	14M036



### Assembly Material

- For one mounting chassis
- **Scope of delivery:**
  - 4 cross recessed cylinder head screw M4 x 6
  - 4 earthing nut M4
  - 4 retaining ring 2 mm

Description	Part-No.
Assembly material for mounting chassis	63-314

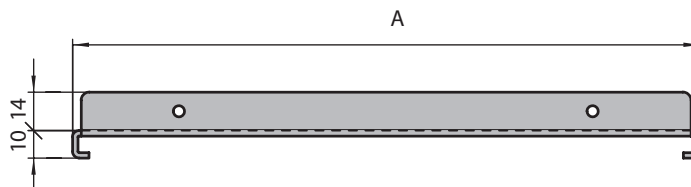

## 1.6.2.2 Mounting Chassis

- For mounting non-standard modules and components
- Mounting chassis is fixed directly to the depth extrusion
- The hole pattern of 200 mm - version allows Elma standard extrusions to be installed for the accommodation of single, double and triple Eurocard-units
- **Scope of delivery:**
  - 1 mounting chassis
- Assembly material see 1.6.2.5



### 1.6.2.2 Mounting Chassis Depth 80mm

Frame Width	A		D		Part-No.
	mm	inch	mm	inch	
84 HP	431.5	16.98	2.0	0.07	14-832

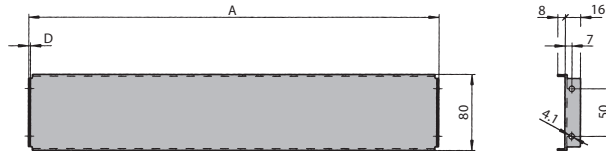

### 1.6.2.3 Mounting Chassis Depth 140 mm

Frame Width	A		D		Part-No.
	mm	inch	mm	inch	
63 HP	324.9	12.79	1.5	0.05	14-834
84 HP	431.5	16.98	2.0	0.07	14-836

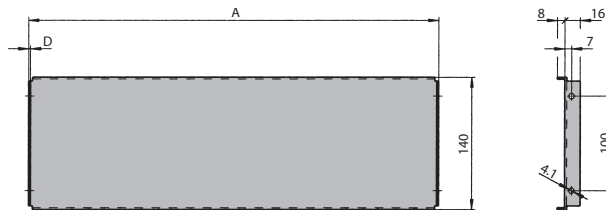

### 1.6.2.4 Mounting Chassis Depth 200 mm

- The hole pattern allows single, double and triple eurocards to be mounted
- Mounting set see 2.5.6.4

Frame Width	A		B		C		D		Part-No.
	mm	inch	mm	inch	mm	inch	mm	inch	
84 HP	431.5	16.98	23.15	0.91	15	0.59	2	0.07	14-840

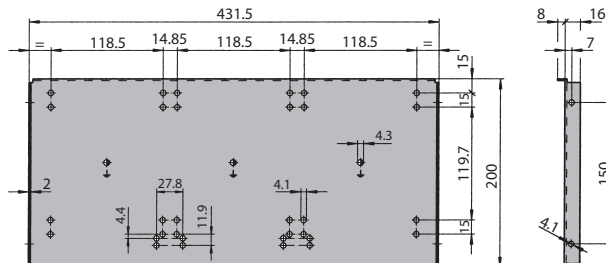

# 1: Unibox 14

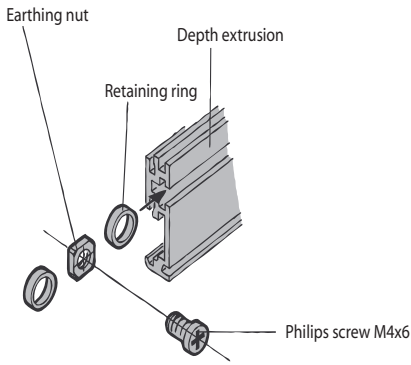

## 1.6.2.5 Assembly Material

Description	Part-No.
For one mounting chassis	63-314

or

Description	Part-No.
Earthing nut M4	61-095
Retaining ring 2 mm	61-015
Philips screw M4x6	5340-06

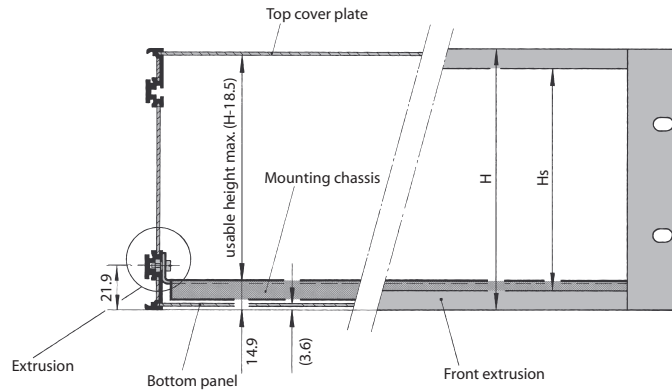

for		2 U	3 U	4 U	5 U	6 U	7 U	8 U	9 U	10 U	12 U
H	mm	88.05	132.50	176.95	221.40	265.85	310.30	354.75	399.20	443.65	532.55
	inch	3.46	5.21	6.96	8.71	10.46	12.21	13.96	15.71	17.46	20.96
Hs	mm	68.05	112.50	156.95	201.40	245.85	290.30	334.75	379.20	423.65	512.55
	inch	2.67	4.42	6.17	7.92	9.67	11.42	13.17	14.92	16.67	20.17

## 1.6.3 Earthing Set

- Enable sub racks and cases to be earthed in conformance with VDE / SEV

### • Scope of delivery:

- 1 earthing nut M4
- 1 threaded bolt M4
- 1 terminal clamp
- 2 lock washer
- 1 nut M4
- 2 retaining rings 2 mm
- 1 earthing symbol

Additional in set for Unibox 14 with cover plates:

- 2 earthing nut M4
- 2 lock washer
- 4 retaining rings 2 mm
- 2 earthing clips
- 2 cross recessed screws M4x6

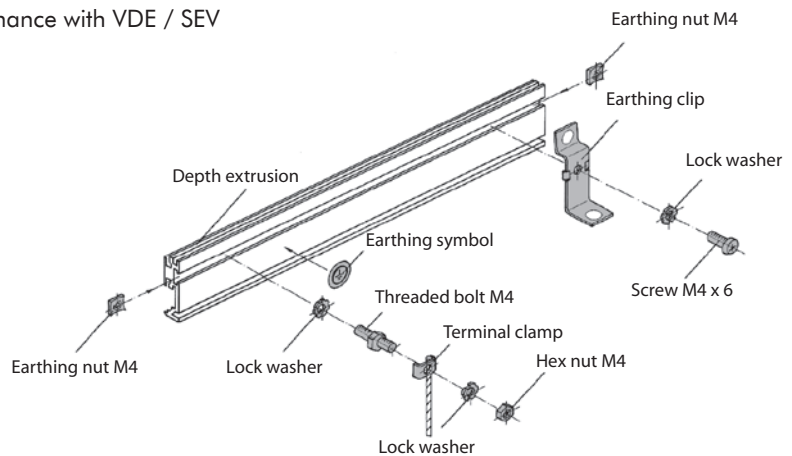

## 1.6.3 Earthing Set

Description	Part-No.
Earthing set for sub racks without cover plates	63-172
Earthing set for sub racks with cover plates	63-173



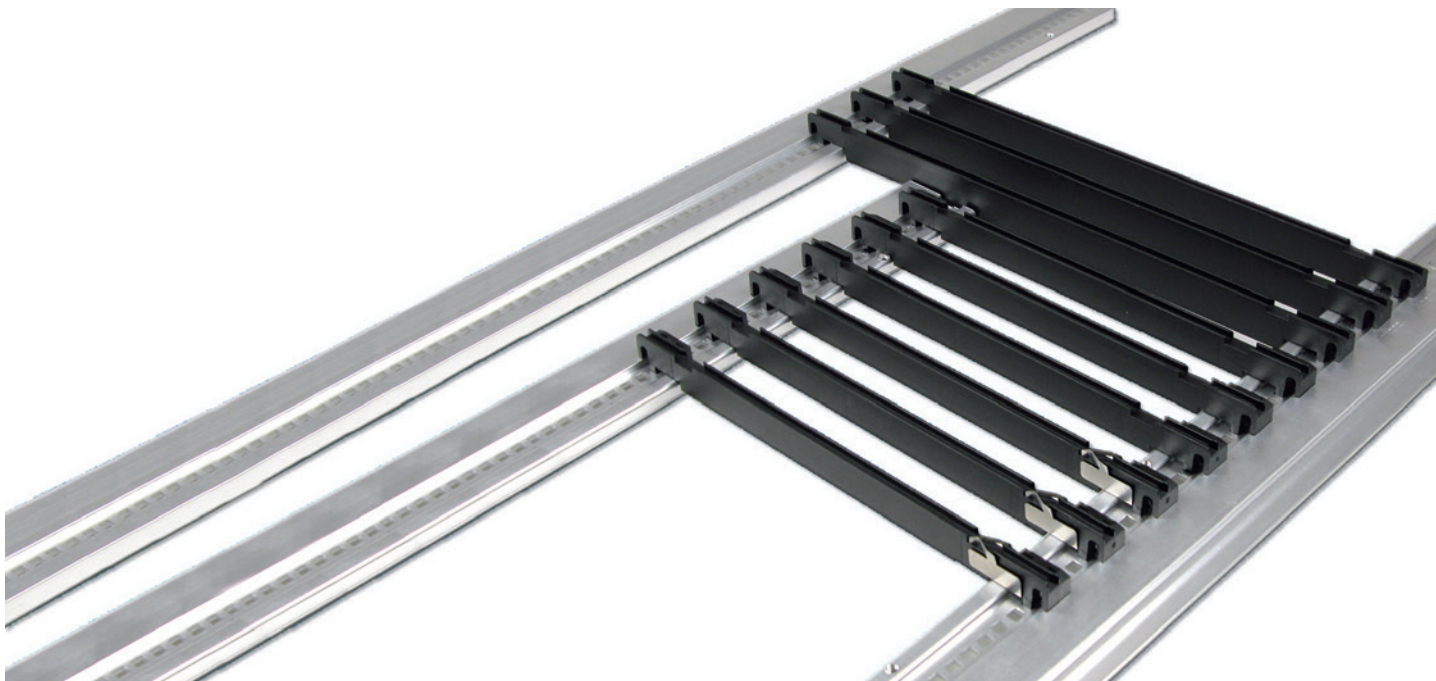

## 1.6.4 Card Guides IEC

- For positive location of circuit boards and plug-in units conforming to the dimensions of card depths of 80 mm, 160 mm, 220 mm and 280 mm
- The card guides are non-flammable, made from a highquality plastic material reinforced with fibreglass
- Including ESD provisions

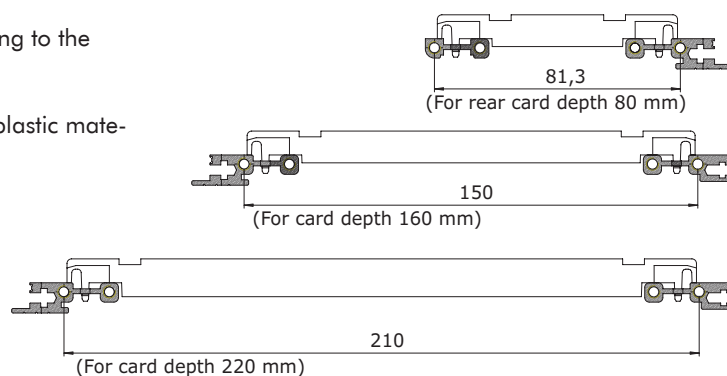

### 1.6.4.1 Card Guides 1-Slot, IEC

- **Scope of delivery:**
  - Card guide black plastic UL94 V-0
  - ESD Clip see below (not usable for card depth 80 mm)



Card Thickness		Card Depth		Part-No.	Part-No.	Part-No.
mm	inch	mm	inch	10 pcs.	100 pcs.	
1.6	0.06	80	3.15	63-319	63-322	–
		160	6.30	63-028	63-029	63-478
		220	8.66	63-103	63-104	63-479
		280	11.02	63-323	63-324	61-017-3
2.0	0.08	160	6.30	63-328	63-329	–
		220	8.66	63-303	63-304	–
		280	11.02	63-445	63-446	–

### ESD Clips

- Connecting printed board with case
- Stainless steel



Description	Part-No.	Part-No.
	10 pcs.	100 pcs.
ESD clip front bottom/rear top	63-863	63-864
ESD clip front top/rear bottom	63-865	63-866



### 1.6.4.2 Card Guides 7-Slot in 4 HP Steps

- For reduced assembly time of multiple slot applications
- For use with single, double and triple eurocards with a depth of 160 mm
- For card thickness: 1.6 mm / 0.06"
- Black plastic, UL94 V-0
- ESD Clip not usable

Card Thickness		Card Depth		Part-No.
mm	inch	mm	inch	
1.6	0.06	160	6.30	61-076



### 1.6.4.3 Card Guides 1-Slot, 3 Parts

- Extrusion: Aluminium / Plastic ABS, (UL 94 V-O)
- End feet: plastic, UL94 HB
- For card thickness: 1.6 mm / 0.06"
- Card guide extrusion, single, clear anodised or plastic grey
- ESD clip not usable

#### Extrusion

Card Depth		Length		Part-No. Plastic	Part-No. Aluminium
mm	inch	mm	inch		
160	6.30	112.5	4.43	61-051	66-122-20
220	8.66	172.5	6.79	61-052	66-122-21
280	11.02	232.5	9.15	61-053*	66-122-22
340	13.38	292.5	11.51	61-054*	66-122-23
400	15.74	352.5	13.87	61-055*	66-122-24
-	-	1350	53.15	61-059	66-122-14

#### End Feet

Description	Part-No. 1 Pair
End feet plastic, UL94 HB	61-069

\* Card guides must be supported in the middle by an additional extrusion (66-138)

### 1.6.4.4 Card Guide Board-Retention Bar

Description	Part-No. 20 pcs.
Board-retention bar, zinc-plated steel	61-291

#### Assembly Material

Description	Part-No.
Cross recessed rounded head screw M3 x 4	5331-04
Torx cylinder head screw M3 x 4, size T10	5470-01

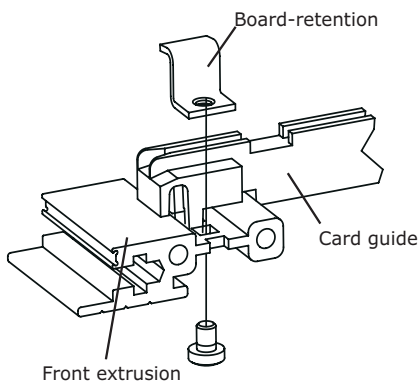

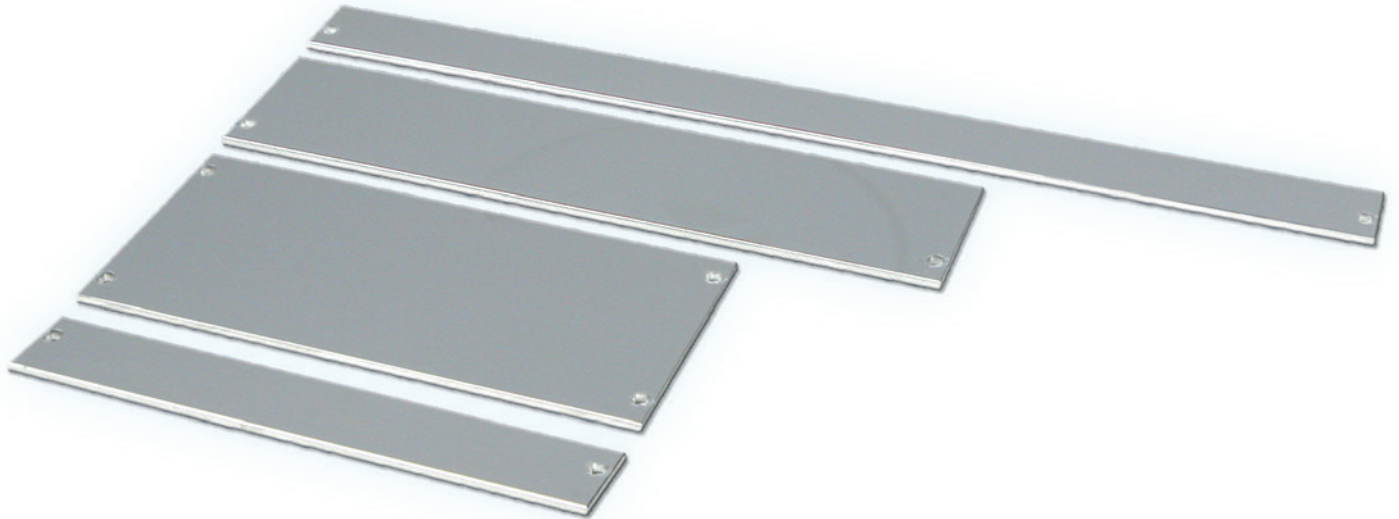

## 1.6.5 Flat Front Panels

- For sub racks and enclosures, solid
- Aluminium 2.5 mm, clear anodised (non-conductive)
- **Scope of delivery:**
  - Flat front panel
- Front panel screws, see below
- 2 HP version: screw retainer can not be filled

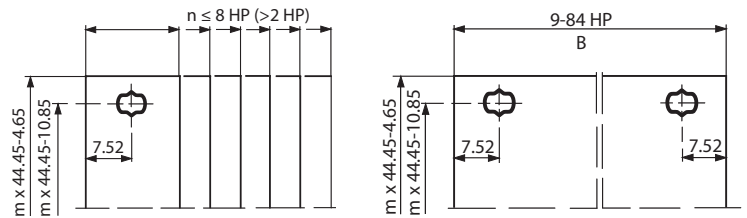

## 1.6.5 Flat Front Panels for Sub Racks and Enclosures, Solid

Width	B		Height		Part-No.					
	mm	inch	1 U 39.8 mm	ca. 1 U* 42.15 mm	2 U 84.2 mm	3 U 128.7 mm	4 U 173.1 mm	6 U 262.0 mm	7 U 306.5 mm	9 U 395.4 mm
2 HP	10.0	0.39	—	—	—	21N302	—	21N602	—	—
3 HP	15.2	0.59	—	—	—	21N303	21N403	21N603	—	—
4 HP	20.1	0.79	—	—	—	21N304	21N404	21N604	—	21N904
5 HP	25.2	0.99	—	—	—	21N305	21N405	21N605	—	—
6 HP	30.3	1.19	—	—	—	21N306	21N406	21N606	—	—
7 HP	35.3	1.38	—	—	—	21N307	21N407	21N607	—	—
8 HP	40.4	1.59	—	—	—	21N308	21N408	21N608	—	—
10 HP	50.6	1.99	—	—	—	21N310	21N410	21N610	—	—
11 HP	55.7	2.19	—	—	—	21N311	—	—	—	—
12 HP	60.7	2.38	—	—	—	21N312	21N412	21N612	—	—
14 HP	70.9	2.79	—	—	—	21N314	21N414	21N614	—	—
16 HP	81.1	3.19	—	—	—	21N316	21N416	21N616	—	—
20 HP	101.4	3.59	—	—	—	21N320	21N420	21N620	—	—
21 HP	106.5	4.19	—	—	—	21N321	—	21N621	—	—
28 HP	142.0	5.59	—	—	—	21N328	—	21N628	—	—
32 HP	162.3	6.38	—	—	—	21N332	21N432	—	—	—
42 HP	213.1	8.38	—	—	21N242	21N342	21N442	21N642	—	—
52 HP	263.9	10.38	—	—	—	21N352	21N452	21N652	—	—
63 HP	319.8	12.59	—	—	21N263	21N363	21N463	21N663	—	—
81 HP	411.3	16.19	—	—	21N281	21N381	21N481	21N681	—	—
84 HP	426.5	16.79	21N184	21N084*	21N284	21N384	21N484	21N684	21N784	21N984

\* Coverplates for 1 U fan opening

### Front Panel Screws

- Set of 10 screws, with screw retainer

Description	Part-No. 10 pcs.
Torx screws M2.5 x 11.3, size T8 with plastic screw retainer	63K159
Rounded head screws recessed M2.5 x 11.3 with plastic screw retainer	63-159



## 1.6.6 Fan Front Panel 84 HP for Vertical Ventilation

- Fan front panels are flat, perforated and designed to ensure an optimum air flow rate
- Available with or without switch cut-out (switch opening 22 x 30.6 mm)
- Aluminium 2.5 mm, clear anodised (non-conductive)
- **Scope of delivery:**
  - 1 perforated fan front panel
- Front panel screws see 1.6.6.1
- On-off switch see 1.6.6.2

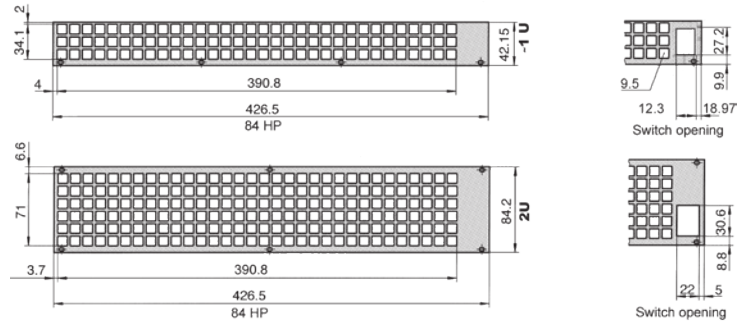

### 1.6.6 Fan Front Panel 84 HP for Vertical Ventilation

Description	Height	Air passage		Part-No.
		mm <sup>2</sup>	sq. in.	
Without switch opening	~ 1 U	8664	13.42	21N084-01
With switch opening	~ 1 U	8664	13.42	21N084-02
Without switch opening	2 U	17328	26.85	21N284-01
With switch opening	2 U	17328	26.85	21N284-02

#### 1.6.6.1 Front Panel Screws

- Set of 10 screws
- With screw retainer
- Fan front panel ~1 U = 4 screws; 2 U = 6 screws

Description	Part-No. 10 pcs.
Torx screws M2.5 x 11.3, size T8, with plastic screw retainer	63K159
Rounded head screws recessed M2.5 x 11.3, with plastic screw retainer	63-159

#### 1.6.6.2 On-Off Switch

- Black body, plastic
- 2 pole (only on-off switches)
- 250V, 16A
- Quick-connect terminal 6.3 x 0.8 mm
- Panel cut-out for 4426-00: 22 x 30.6 mm (0.87" x 1.20")
- Panel cut-out others: 12.3 x 27.2 mm (0.48 x 1.07")

Description	Part-No.
On-off switch, indicator light green	69-410-04
On-off switch, without signal light	69-410-09





## 1.6.7 Fan Front Panel for Horizontal Ventilation

- Aluminium 2.5 mm, clear anodised (non-conductive)
- Scope of delivery:**
  - 1 perforated fan front panel
- Front panel screws see below

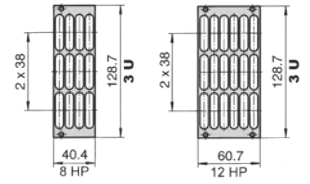

### 1.6.7 Fan Front Panel for Horizontal Ventilation

Height	Width	Air passage		Part-No.
		mm <sup>2</sup>	sq. inch	
3 U	8 HP	3195	4.95	21N308-01
	12 HP	4793	7.42	21N312-01

#### Front Panel Screws

- Set of 10 screws
- With screw retainer
- Fan front panel width up to 8 HP = 2 screws; ≥ 12 HP = 4 screws

Description	Part-No.
Torx screws M2.5 x 11.3, size T8 with plastic screw retainer	63K159
Rounded head screws recessed M2.5 x 11.3 with plastic screw retainer	63-159

## 1.6.8 Fan Front Panels for Direct Fan Mounting

- Aluminium 2.5 mm, clear anodised (non-conductive)
- Scope of delivery:**
  - 1 perforated fan front panel
- Front panel screws see 1.6.8.1
- Assembly material for fan mounting has to be ordered separately

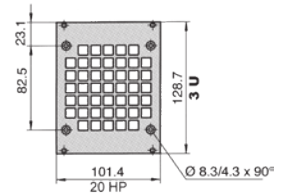

### 1.6.8 Fan Front Panels for Direct Fan Mounting

Description	Height	Width	Air passage		Part-No.
			mm <sup>2</sup>	sq. inch	
Without switch opening	3 U	20 HP	4051	6.27	21N320-04

#### 1.6.8.1 Front Panel Screws

- Set of 10 screws
- With screw retainer
- Per front panel 4 screws are needed

Description	Part-No.
Torx screws M2.5 x 11.3, size T8 with plastic screw retainer	63K159
Rounded head screws recessed M2.5 x 11.3 with plastic screw retainer	63-159

#### 1.6.8.2 Assembly Material for Fan Mounting

Description	Part-No.
Countersunk screw, cross recessed M4 x 10	5342-10
Hexagonal nut M4, 0.8D	5620-51



## 1.6.9 Top / Bottom-Hinged Front Panel

- Hinges are attached to the front extrusions of the sub rack or case
- Aluminium 2.5 mm, clear anodised (non-conductive)
- **Scope of delivery:**
  - Front panel
  - Hinge extrusion
  - Assembly material M2.5, incl. hinges

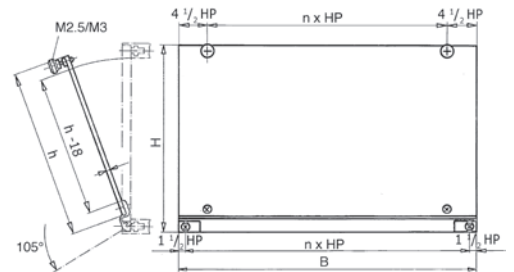

### 1.6.9 Top/Bottom-Hinged Front Panel

Width	Part-No. 3 U	Part-No. 4 U	Part-No. 6 U	Part-No. 7 U
84 HP	25N384-19	25N484-19	25N684-19	25N784-19

#### Dimensions

Nominal Width			Width B	
HP	mm	inch	mm	inch
84 HP	426.72	16.80	426.5	16.79

Nominal Height		Height H		Height h	
U	mm	inch	mm	inch	mm
3 U	128.7	5.07	117	4.61	
4 U	173.15	6.81	161.4	6.35	
6 U	262.05	10.31	250.3	9.85	
7 U	306.5	12.07	294.8	11.60	

## 1.6.10 Side-Hinged Front Panel

- Aluminium 2.5 mm, clear anodised (non-conductive)
- **Scope of delivery:**
  - Front panel
  - Hinge extrusion
  - Assembly material M2.5, incl. hinges



### 1.6.10 Side-Hinged Front Panel

Width	Part-No. 3 U	Part-No. 6 U	Part-No. 7 U
84 HP	25N384-29	25N684-29	25N784-29

### Dimensions

Nominal Width			Width B		Width b	
HP	mm	inch	mm	inch	mm	inch
84 HP	426.72	16.80	426.5	16.79	414.3	16.31

Nominal Height	Height H	
U	mm	inch
3 U	128.7	5.06
6 U	262.05	10.31
7 U	306.5	12.07

Use Elma's front panel service for machining and screen printing of your panels!



## 1.6.11 Extruded Front Panels

- Aluminium 2.5 mm, clear anodised (non-conductive)
- PCB mounting lugs are formed on the rear face of the panel
- No PCB fixing screws on the front face of the panel, leaving more space for silk screening and mounting front panel components
- Suitable for all sub racks and cases
- Thickness of the mounting lugs (3.48 mm) allows PCBs to be mounted on either side of the lugs
- At rear drill marks for handle-fixing holes
- **Scope of delivery:**
  - Extruded front panel, clear anodised
- Front panel screws see 1.6.11.1

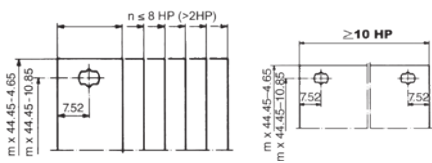
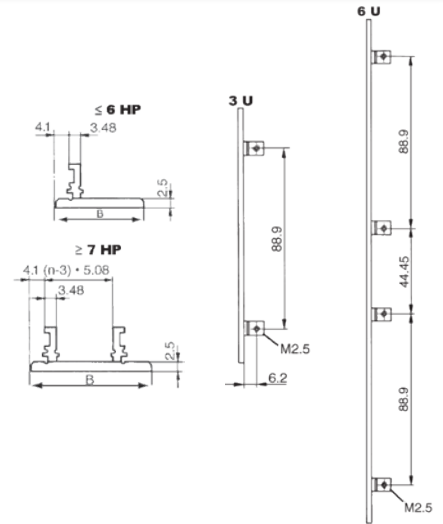

### 1.6.11 Extruded Front Panels, without Openings

Width	B		Part-No. 3 U	Part-No. 6 U
	mm	inch		
3 HP	15.0	0.59	26N303	26N603
4 HP	20.1	0.79	26N304	26N604
5 HP	25.2	0.99	26N305	26N605
6 HP	30.3	1.19	26N306	26N606
7 HP	35.3	1.38	26N307	26N607
8 HP	40.4	1.59	26N308	26N608
10 HP	50.6	1.99	26N310	26N610
12 HP	60.7	2.38	26N312	26N612
14 HP	70.9	2.79	26N314	26N614
16 HP	81.1	3.19	26N316	26N616
21 HP	106.5	4.19	26N321	-

#### 1.6.11.1 Front Panel Screws

- Set of 10 screws
- With screw retainer
- Front panel width up to 9 HP = 2 screws; ≥ 10 HP = 4 screws

Description	Part-No. 10 pcs.
Torx screws M2.5 x 11.3, size T8, with plastic screw retainer	63K159
Rounded head screws recessed M2.5 x 11.3, with plastic screw retainer	63-159

# 1: Unibox 14

## 1.6.11.2 Rigid-Mounted Unit Handles with Identification Label

- Black, plastic UL94 V-0, label aluminium anodised
- **Scope of delivery:**
  - Rigid-mounted handle
  - Identification label
- Assembly material see below

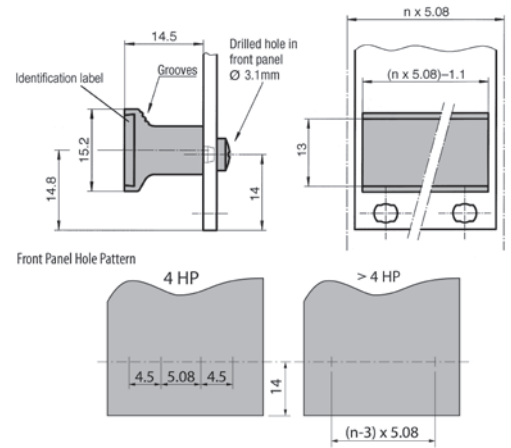

## 1.6.11.2 Rigid-Mounted Handle with Identification Label

Width	Scope of Delivery	Part-No.
4 HP	10 pcs.	60-200-04
5 HP	10 pcs.	60-200-05
6 HP	10 pcs.	60-200-06
7 HP	10 pcs.	60-200-07
8 HP	10 pcs.	60-200-08
10 HP	10 pcs.	60-200-10
12 HP	10 pcs.	60-200-12
14 HP	1 pc.	60-200-14

- Other sizes (up to 84 HP) are available upon request

### Assembly Material

Description	Part-No.
Cross recessed rounded head screw	61-276

## 1.6.11.3 Fluted Handles

- Extruded aluminium handles, shaped to facilitate withdrawal of plug-in units
- Two grooves in the front face will accept identification strips (0.5 x 9 mm)
- **Scope of delivery:**
  - Extruded handle, clear anodised
  - Assembly material

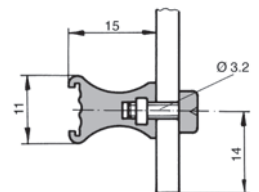

## 1.6.11.3 Fluted Handles for Front Panels to IEC

Front Panel Width HP	Width		Handle Length		Part-No.
	mm	inch	mm	inch	
3 HP	15.0	0.59	12.5	0.49	60-103
4 HP	20.1	0.79	17.6	0.69	60-104
5 HP	25.2	0.99	22.6	0.88	60-105
6 HP	30.3	1.19	27.7	1.09	60-106
7 HP	35.3	1.38	33.5	1.31	60-107
8 HP	40.4	1.59	37.9	1.49	60-108
10 HP	50.6	1.99	48.0	1.88	60-110
12 HP	60.8	2.39	58.2	2.29	60-112
14 HP	70.9	2.79	69.1	2.72	60-114
16 HP	81.1	3.19	78.5	3.09	60-116
21 HP	106.5	4.18	104.6	4.11	60-121
30 HP	152.2	5.99	149.6	5.88	60-130
40 HP	203.0	7.99	200.4	7.88	60-140
60 HP	304.6	11.99	302.0	11.88	60-160
84 HP	426.5	16.79	424.0	16.69	60-184

# 1: Unibox 14

## 1.6.12 Front Panel with Cutout for IEC Ejector Handle

- Aluminium 2.5 mm, clear anodised (non-conductive)
- PCB mounting lugs are formed on the rear face of the panel (only 3 U-Version)
- No PCB fixing screws on the front face of the panel, leaving more space for silk screening and mounting front panel components
- Suitable for all sub racks and cases
- 3 U front panels prepared for one handle
- 6 U front panels prepared for two handles
- **Scope of delivery:**
  - Front panel, clear anodised
- Front panel screws see 2.1.2.1 (for 3 U-Version only)
- IEC ejector handles, see 2.1.2.2

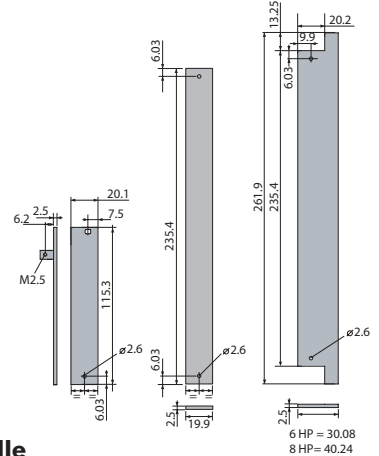

### 2.1.2 Front Panel with Cutout for IEC Ejector Handle

Width	B		Part-No. 3 U	Part-No. 6 U
	mm	inch		
4 HP	20.0	0.79	26N304-51	21N604-51
6 HP	30.2	1.19		21N606-51
8 HP	40.3	1.59		21N608-51

#### 2.1.2.1 Front Panel Screws (for 3 U-Version only)

- Set of 10 screws
- With screw retainer
- Front panel 3 U = 1 screw

Description	Part-No. 10 pcs.
Torx screws M2.5 x 11.3, size T8, with plastic screw retainer	63K159
Rounded head screws recessed M2.5 x 11.3, with plastic screw retainer	63-159

### 1.6.12.2 Ergonomic Ejector Handles acc. to IEC

- Simple assembly of plug-in units
- Allows trouble-free extraction of electronic units with multi-pole connectors
- Main features in one part: card holder, ejector handle and centring pin
- Reset spring for safe insertion
- One version for top and bottom only
- Handle is injection moulded, glass-reinforced plastic, UL94 V-0
- Card holder is zinc die-cast, nickel plated
- Reset spring is stainless steel
- **Scope of delivery:**
  - Ejector handle
  - Assembly material (screws M2.5 for fixing of card holder/printed board/front panel)
- Front panel with special cutouts have to be ordered separately

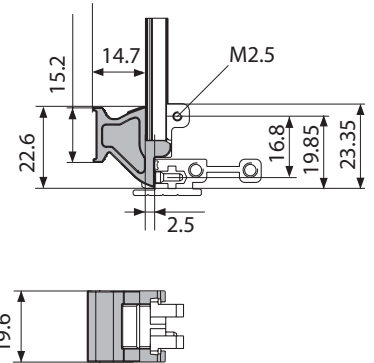

### 2.1.2.2 Ejector Handle acc. to IEC

Description	Part-No.
Ejector handle black	81-233
Ejector handle grey	81-234

#### Extraction process:

Rest position      Extraction      End position

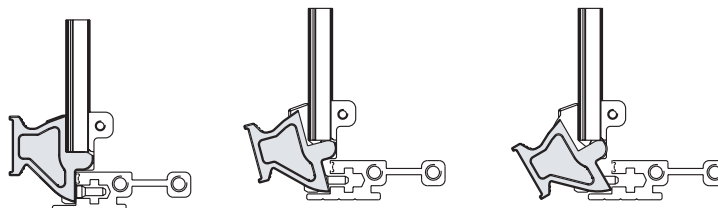

#### Label

Description	Part-No.
1 sheet A4 of 220 labels	81-031

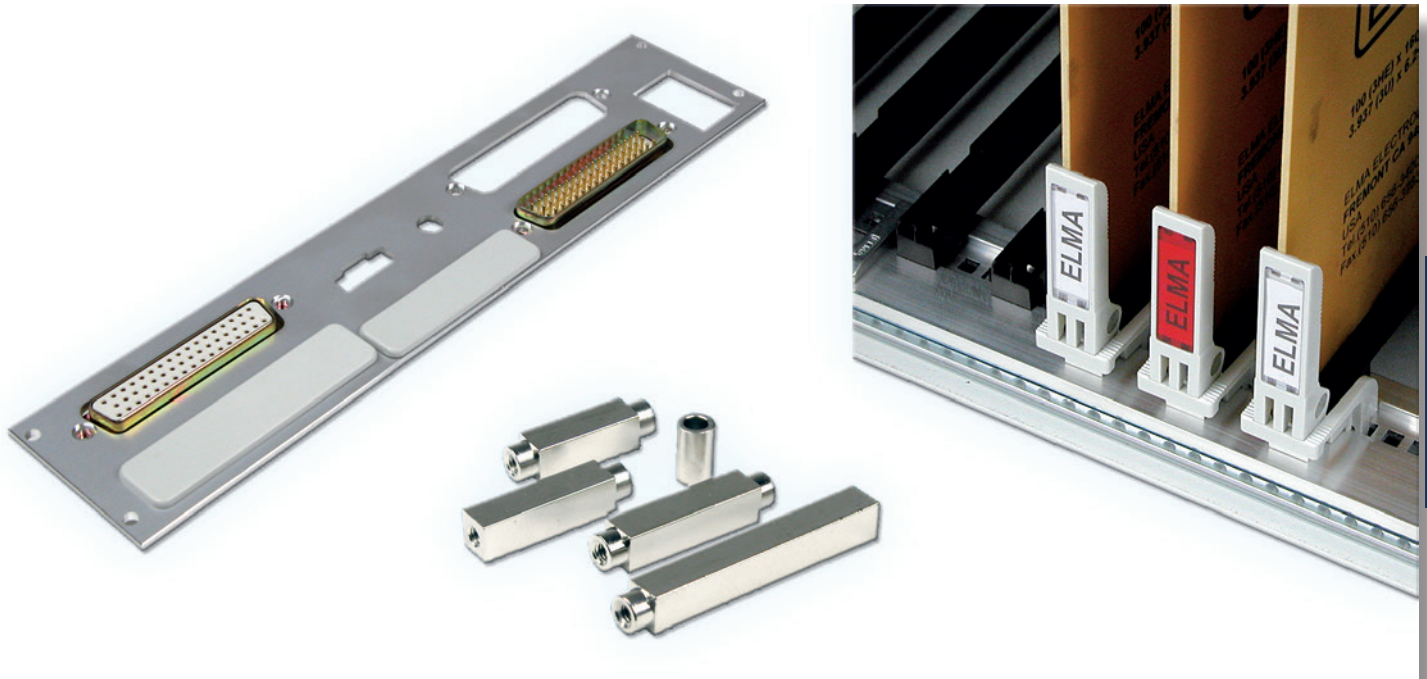

## 1.6.13 Card Locks and Card Handles

- The card lock is easily mounted onto the upper or lower front profile
- When the PCB is pushed home, it is automatically locked into position
- The card eject mechanism can be attached to the top or bottom front edge of the PCB and is used in conjunction with the card lock
- The lever action ensures smooth and jerk-free card removal, especially useful when multi-pole connectors are being used
- Transparent windows in different colours and self-adhesive labels set into the front face of the eject mechanism make card identification easy
- The card lock and eject mechanism does not inhibit the use of front panels
- For recessed cards, a special card lock is available, suitable for use with profile 66-144
- **Scope of delivery:**
  - Card locks, eject mechanisms, windows and labels



### 1.6.13.1 Card Locks, Card Injector/Ejector Handles

Description	Colour	Part-No.	
		1 pc.	10 pcs.
Card ejector handles		-	63-151
Card locks		61-126	63-153
Card locks to 66-144		61-144	63-163
Transparent window	Clear	-	63-155-1
	Red	-	63-155-4

- Other colours (yellow, green, blue, orange) upon request

### 1.6.13.2 Labels

Description	Part-No.
1 sheet A4 of 105	63-161

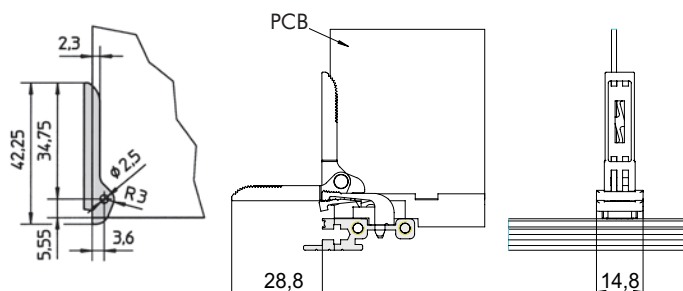
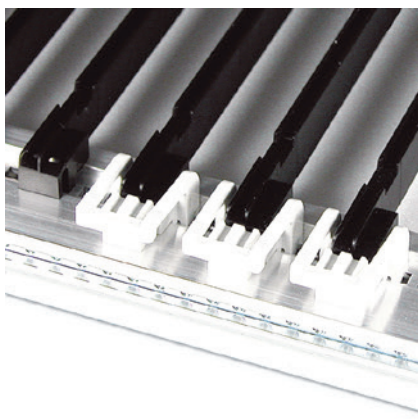

## 1.6.13.3 Card Handles

- Coloured, transparent handles which will accept labels facilitate the handling and identification of PCBs
- **Scope of delivery:**
  - 1 card handle
- Two screws M2.5 x 5 are needed per handle and have to be ordered separately

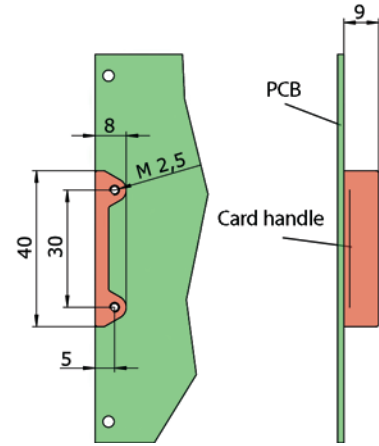

## 1.6.13.3 Card Handles

Description	Colour	Part-No.
Card handle	clear	1091-51
	red	1091-54
Cylindrical screw M2.5 x 5		5571-05
Torx cylinder head screw M2.5 x 5, size T8		5470-07

- Other colours (blue, yellow, green, orange) upon request





# 1: Unibox 14

## 1.6.14 Card Holder acc. to IEC Standard

- By using the zinc die-cast card holder, flat front panels can be connected to a PC card to form a plug-in unit to IEC 60297
- The card can be mounted both in the standard position and offset 1 HP (5.08 mm)
- For better positioning of 6 U cards, there is a card holder centre piece made of nylon (see 1.6.15)
- The injector-/ejector handle can be used with the card holder
- **Scope of delivery:**
  - 1 card holder
- Assembly material see 1.6.14.3

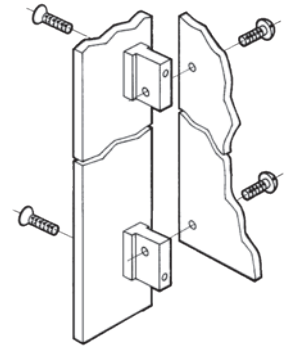

### 1.6.14.1 Card Holder without Swivel Stop

Description	Application	D	Part-No.
Card holder without swivel stop	Without injector/ejector handle	M2.5	61-156
Card holder without swivel stop	With injector/ejector handle	Ø 2.5	61-155

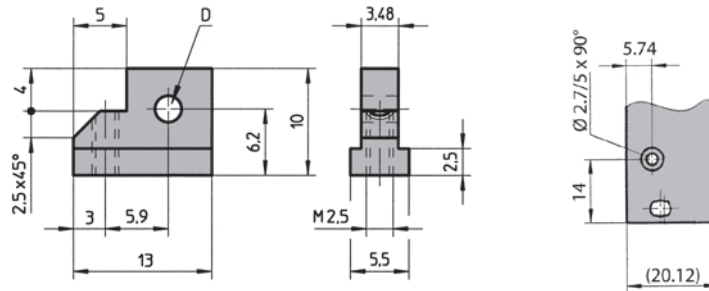

### 1.6.14.2 Card Holder with Swivel Stop

Description	Application	D	Part-No.
Card holder with swivel stop	Without injector/ejector handle	M2.5	61-156-01
Card holder with swivel stop	With injector/ejector handle	Ø 2.5	61-155-01

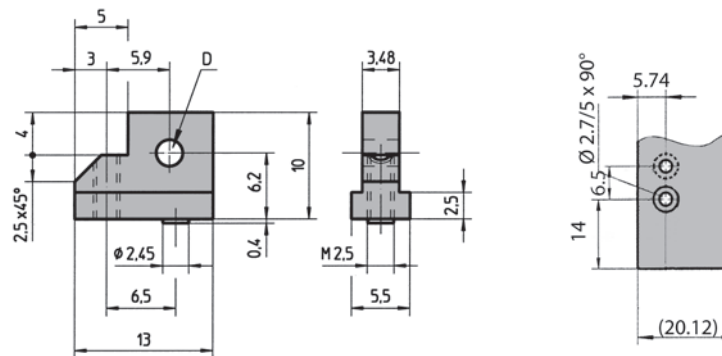

### 1.6.14.3 Assembly Material

Description	Application	Part-No.
Cross recessed countersunk screw M2.5 x 8	For card holder	5322-08
Torx countersunk screw M2.5 x 8, size T8	For card holder	5470-21
Slotted pan head screw M2.5 x 6	For printed board	5571-06
Torx cylinder head screw M2.5 x 6, size T8	For printed board	5470-04



## 1.6.15 Middle Part

- Usable for all front panels
- For positioning and fixing of 6 U and 9 U card circuit
- Card thickness 1.6 mm
- Self-adhesive, can optionally be screwed onto front panel and printed board
- Material: Plastic black UL94 V-0
- **Scope of delivery:**
  - Plastic middle part
- Assembly material, see 1.6.15.1

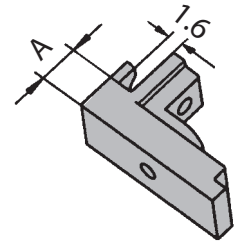

### 1.6.15 Middle Part

For Front Panels out of	A		Part-No.
	mm	inch	
Aluminium 2.5 mm	2.5	0.10	61-960

### 1.6.15.1 Assembly Material

Description	Part-No.
PT-countersunk, 2.5 x 6	5534-06



## 1.6.16 Protective Cover for 6 U Printed Board

1. Slide protective cover between front panel and printed board
2. Press adhesive tape on protective cover through pins of connectors to attach onto printed board

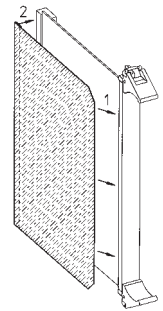

### 1.6.16 Protective Cover for 6 U Printed Board

- Material: Polyester film mat, thickness 0.2 mm, UL94 VTM-2
- Mechanical protection of soldering side

For Card Depth		Part-No.
mm	inch	
160	6.30	81-010-02



## 1.6.17 Spacers

- Four-sided, nickel-plated brass spacers with M2.5 internal threads at both ends
- Using these spacers, additional PCBs may be mounted at a horizontal pitch of 5.08 mm
- Mounting plate is 1.5 mm galvanized steel with mounting holes corresponding to PCBs conforming to IEC 60297

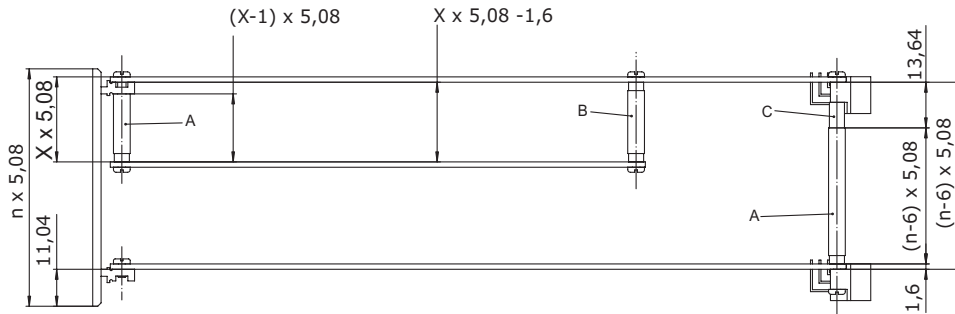

- $n * 5.08$  = theoretical width of front panel
- $x * 5.08$  = distance of printed PCBs
- $n$  = multiple of the 5.08 pitch of the selected front panel
- $x$  = selected multiple of the 5.08 pitch for the distance of printed PCBs

### 1.6.17.1 Spacers Series A

- Use between PCB mounting lugs and PCBs
- Gives 5.08 mm pitch

Length L		Part-No.
mm	inch	
10.16	0.40	61-300
15.24	0.60	61-301
20.32	0.80	61-302

Other lengths available on request.



### Series A

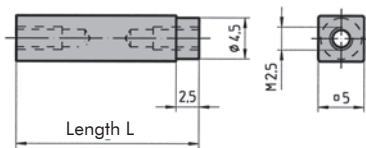

### Series B

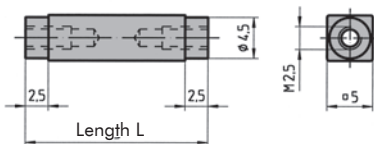

### Series C

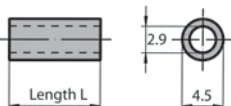

### 1.6.17.2 Spacers Series B

- Use between two PCBs
- Gives 5.08 mm pitch

Length L		Part-No.
mm	inch	
13.64	0.53	61-320
18.72	0.73	61-321
23.80	0.93	61-322

### 1.6.17.3 Spacers Series C

- Use between a PCB with connector and a second PCB

Length L		Part-No.
mm	inch	
7.64	0.30	61-340

# 1: Unibox 14

## 1.6.18 Mounting Plates

- Dimensions identical to eurocard dimensions
- 1.5 mm galvanized sheet steel
- **Scope of delivery:**
  - 1 mounting plate
- Assembly material, see below

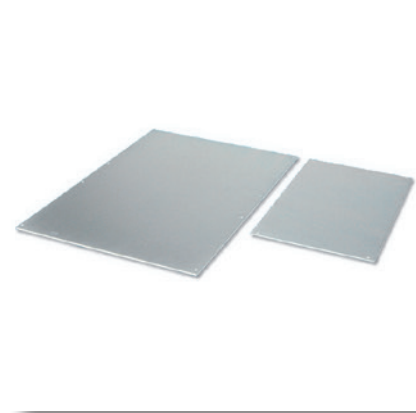

### 1.6.18 Mounting Plates

Height	Dimensions	Part-No.
3 U	100 x 160 mm (3.93" x 6.29")	61-350
6 U	233.35 x 160 mm (9.18" x 6.29")	61-351

### Assembly Material

Description	Part-No.
Screws recessed M2.5 x 5	5571-05

## 1.6.19 Hexagonal Spacers M3 Thread

- Galvanised steel
- Ideal for use as supports or spacers
- **Scope of delivery:**
  - 1 spacer



### 1922-0x

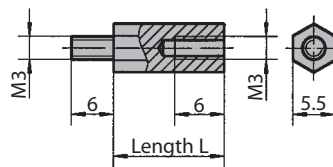

### 1923-0x

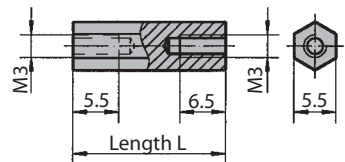

### 1.6.19 Hexagonal Spacers, M3 Thread

Length L		Part-No.
mm	inch	
10	0.39	1922-01
15	0.59	1922-02
30	1.18	1922-05
40	1.57	1922-07

Length L		Part-No.
mm	inch	
8.5	0.33	1923-01
13.5	0.53	1923-02

## 1.6.20 Covering Caps

- The caps, fit openings for D-Sub connectors and can be fitted without special tools
- Material: ABS grey UL94 HB
- **Scope of delivery:**
  - Plastic covering caps

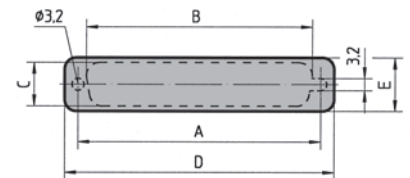

### 1.6.20 Covering Caps

Opening	A	B	C	D	E	Part-No.
	mm	mm	mm	mm	mm	
DB9 9-pole	25.0	20.5	11.4	32.0	14.0	61-920
DB15 15-pole	33.3	28.8	11.4	40.3	14.0	61-921
DB25 25-pole	47.0	42.5	11.4	54.0	14.0	61-922
DB37 37-pole	63.5	59.1	11.4	70.5	14.0	61-923

## 1.6.21 Mounting Bracket

- Assembly of a separation
- Separations are manufactured as required by the customer
- Sheet steel
- **Scope of delivery:**
  - 1 mounting bracket
- Assembly material, see below

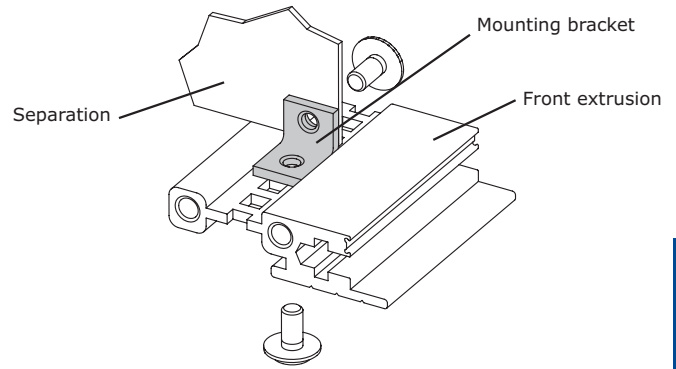

### 1.6.21 Mounting Bracket

Description	Part-No.
Mounting brackets	61-416

### Assembly Material

Description	Part-No.
Rounded head screws cross recessed M3 x 6	5335-06
Rounded head screws Torx M3 x 6, size T10	5473-01

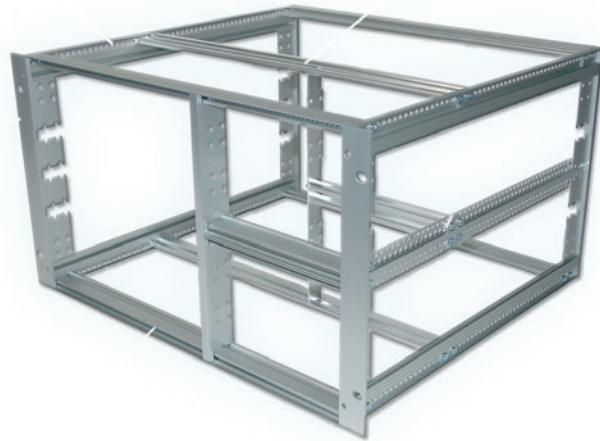

## 1.7 Extrusions

### 1.7.1 Front Extrusions

#### 1.7.1.1 Front Extrusion 66-111, IEC

- For sub rack and cases front
- **Scope of delivery:**
  - 1 front extrusion without assembly material

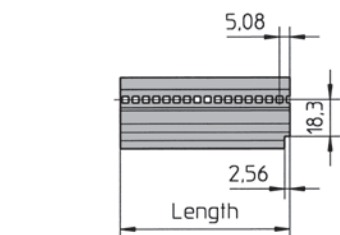
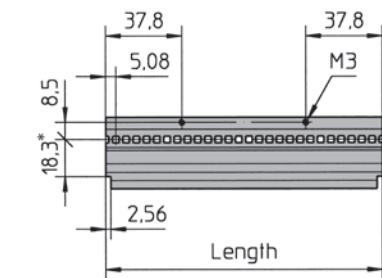
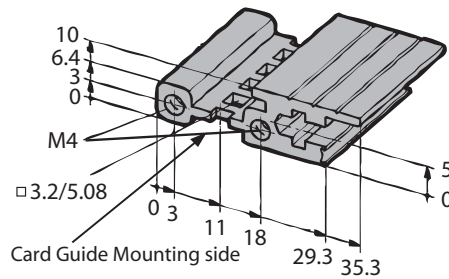

#### Standard version

Length for HP	Length		Part-No. clear anodised	black anodised	clear passivated	raw
	mm	inch				
21	111.8	4.40	66-111-26			
28	147.3	5.80	66-111-25			
32	167.6	6.80	66-111-62			
42	218.4	8.60	66-111-60		66-111-75	
63	325.1	12.80	66-111-61		66-111-76	
81	416.6	16.40	66-111-22		66-111-77	
84	431.8	17.00	66-111-23	66-111-56	66-111-78	66-111-28
	1350.0	53.15				66-111-19

Note: Throughout the catalogue all EMC parts are highlighted in yellow

#### Height divider right

Length for HP	Length		Part-No. anodised
	mm	inch	
8.5	43.18	1.70	66-111-71
12.5	63.82	2.54	66-111-72

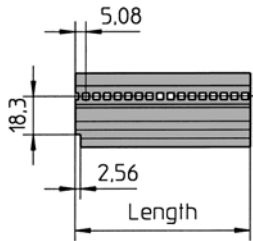

## Height divider left

Length for HP	mm		Part-No. anodised
	mm	inch	
8.5	43.18	1.70	66-111-81
12.5	63.82	2.54	66-111-82

## 1.7.2 Height Extrusions

### 1.7.2.1 Height Extrusion 66-173

- Height extrusion for Unibox 14
- Slim version with or without fixing hole for handle
- **Scope of delivery:**
  - 1 height extrusion without assembly material

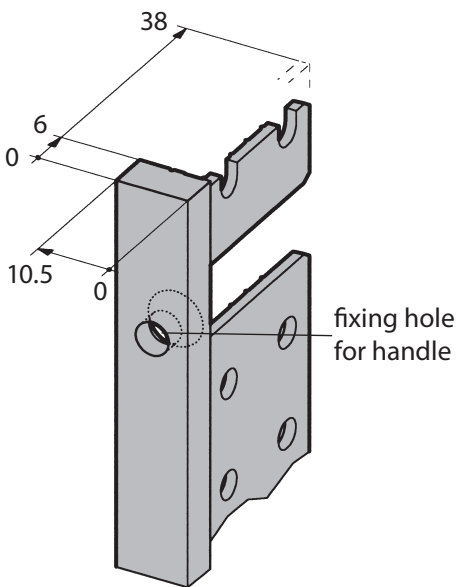

### 1.7.2.1 Height Extrusion 66-173

Length for U	mm		Part-No. clear anodised fixing hole for handle	
	mm	inch	without	with
2	88.1	3.46	66-173-20	66-173-21
3	132.5	5.20	66-173-22	66-173-23
4	177.0	6.96	66-173-24	66-173-25
5	221.5	8.72	66-173-26	66-173-27
6	265.9	10.46	66-173-28	66-173-29

### 1.7.2.2 Height Extrusion 66-179

- With or without fixing hole for handle
- 19" height extrusion for Unibox 14 / 84 HP
- **Scope of delivery:**
  - 1 height extrusion without assembly material

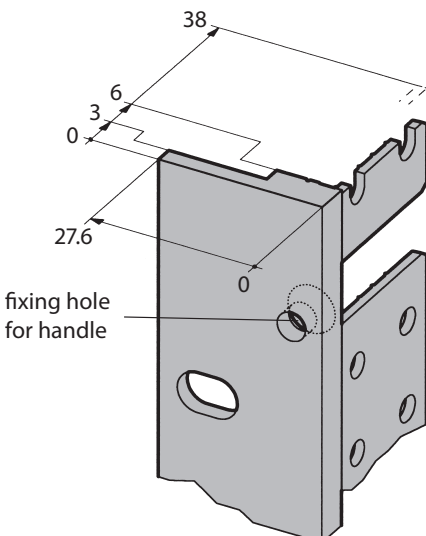

### 1.7.2.2 Height Extrusion 66-179

Length for U	mm		Part-No. clear anodised fixing hole for handle	
	mm	inch	without	with
2	88.1	3.46	66-179-22	66-179-32
3	132.5	5.20	66-179-23	66-179-33
4	177.0	6.96	66-179-24	66-179-34
5	221.5	8.72	66-179-25	66-179-35
6	265.9	10.46	66-179-26	66-179-36
7	310.3	12.20	66-179-27	66-179-37
8	354.8	13.96	66-179-28	66-179-38
9	399.2	15.71	66-179-29	66-179-39

## 1.7.3 Depth Extrusions

### 1.7.3.1 Depth Extrusion 66-177

- Depth extrusion for universal sub rack Unibox 14
- **Scope of delivery:**
  - 1 depth extrusion without assembly material

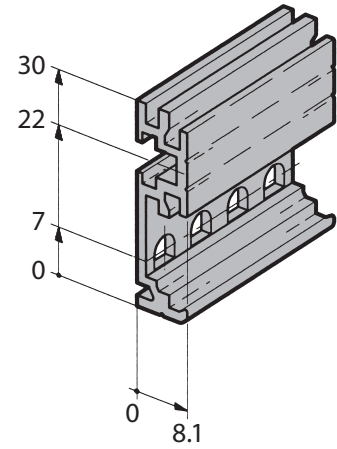

### 1.7.3.1 Depth Extrusion 66-177

Length		Part-No. clear
232.6	9.15	66-177-21
292.6	11.51	66-177-22
352.6	13.55	66-177-23
412.6	16.24	66-177-24
532.6	20.96	66-177-26

### 1.7.3.2 Depth Divider Extrusion 66-176

- Depth divider extrusion for universal sub rack Unibox 14
- **Scope of delivery:**
  - 1 depth extrusion without assembly material

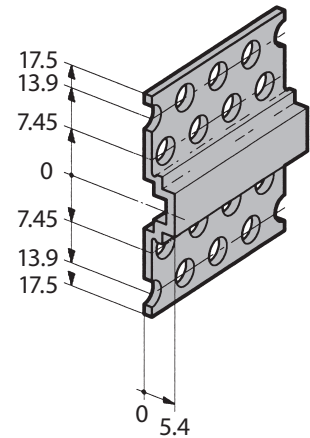

### 1.7.3.2 Depth Divider Extrusion 66-176

Length		Part-No. clear passivated
mm	inch	
292	11.49	66-176-22
412	16.22	66-176-24
532	20.94	66-176-26

Note: Throughout the catalogue all EMC parts are highlighted in yellow



## 1.7.4 Internal Extrusions

### 1.7.4.1 Standard Internal Extrusion 66-144

- Standard extrusion for mounting supplementary edge connector extrusions in sub racks and cases
- **Scope of delivery:**
  - 1 internal extrusion without assembly material

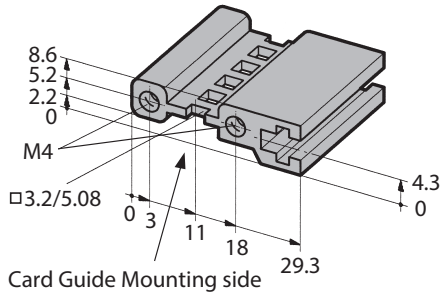

### 1.7.4.1 Standard Internal Extrusion 66-144

Length for HP	mm	inch	Part-No.	
			clear passivated	raw
42	218.4	8.60	66-144-60	-
63	325.1	12.80	66-144-61	-
81	416.6	16.40	66-144-22	-
84	431.8	17.00	66-144-23	-
	1350.0	53.14	-	66-144-19

Note: Throughout the catalogue all EMC parts are highlighted in yellow

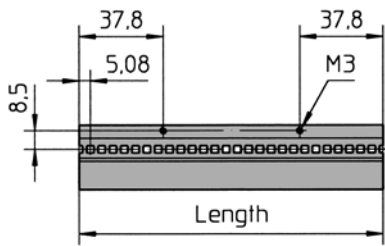

### 1.7.4.2 Internal Extrusion 66-193 for Insulated Backplane Mounting

- For mounting backplanes in sub racks, grooved to accept 1.8 x 5 mm tapped strips
- To use with insulation strips 66-901
- **Scope of delivery:**
  - 1 internal extrusion without assembly material

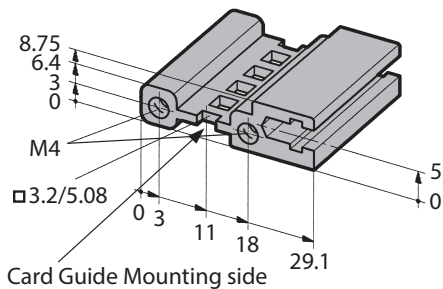

### 1.7.4.2 Internal Extrusion 66-193 for Use of Insulating Strip

Length for HP	mm	inch	Part-No.
			clear passivated
81	416.6	16.40	66-193-24
84	431.8	17.00	66-193-25

Note: Throughout the catalogue all EMC parts are highlighted in yellow

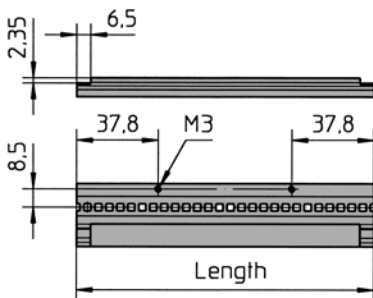

# 1: Unibox 14

## 1.7.4.3 Insulating Strips 66-901

- Plastic grey
- In use with extrusions 66-112, 66-192, 66-193, 66-288

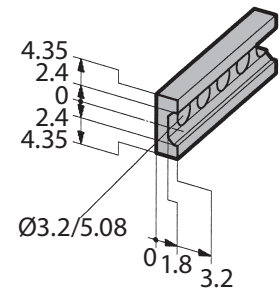

## 1.7.4.3 Insulating Strips 66-901

Length for HP	Length		Part-No.
	mm	inch	
42	216.44	8.52	66-901-20
63	323.12	12.72	66-901-21
81	414.56	16.32	66-901-22
84	429.80	16.92	66-901-23

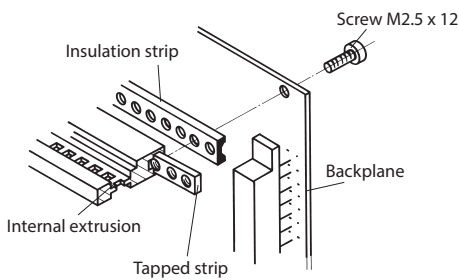

## Mounting with Insulation Strips

Part	Part-No.
Screw to insulation extrusion	5325-12

## 1.7.4.4 Internal Extrusion 66-194 for Conductive Backplane Mounting

- For mounting backplanes without an insulating strip
- Grooved to accept 1.8 x 5 mm tapped strips
- **Scope of delivery:**
  - 1 internal extrusion without assembly material

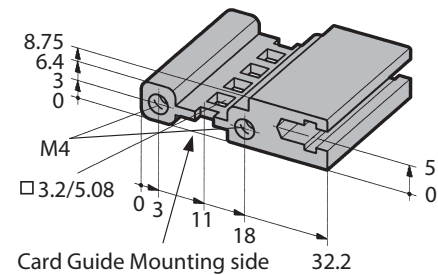

## 1.7.4.4 Internal Extrusion 66-194 without Use of Insulating Strip

Length for HP	Length		Holes n x C	Part-No. clear passivated
	mm	inch		
81	416.6	16.40	2 x 170.48	66-194-24
84	431.8	17.00	2 x 178.1	66-194-25

Note: Throughout the catalogue all EMC parts are highlighted in yellow

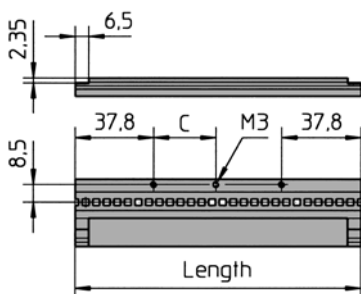

## 1.7.5 Edge Connector Extrusions

### 1.7.5.1 Edge Connector Extrusion 66-145

- Supplementary edge connector extrusion for IEC 60603-2 connectors
- Matches 66-144, 66-133 and 66-124
- **Scope of delivery:**
  - 1 supplementary edge connector extrusion without assembly material

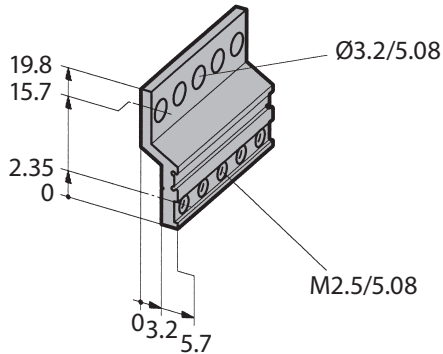

### 1.7.5.1 Edge Connector Extrusion 66-145

Length for HP	mm	inch	Part-No.	
			clear passivated	raw
8	40.6	1.59	66-145-40	
18	91.4	3.59	66-145-41	
28	142.2	5.60	66-145-42	
42	213.4	8.40	66-145-63	
63	320.0	12.60	66-145-65	
81	411.5	16.20	66-145-22	
84	426.7	16.80	66-145-52	
	1350.0	53.14		66-145-19

Note: Throughout the catalogue all EMC parts are highlighted in yellow

### 1.7.5.2 Edge Connector Extrusion 66-147

- Supplementary edge connector extrusion for IEC 60603-2
- Matches 66-112, 66-192 and 66-193
- **Scope of delivery:**
  - 1 supplementary edge connector extrusion without assembly material

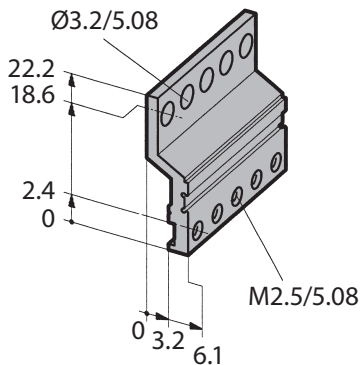

### 1.7.5.2 Edge Connector Extrusion 66-147

Length for HP	mm	inch	Part-No.	
			clear passivated	raw
8	40.6	1.59	66-147-40	
18	91.4	3.59	66-147-41	
28	142.2	5.60	66-147-42	
42	213.4	8.40	66-147-63	
63	320.0	12.60	66-147-65	
81	411.5	16.20	66-147-22	
84	426.7	16.80	66-147-52	
	1350.0	53.14		66-147-19

Note: Throughout the catalogue all EMC parts are highlighted in yellow

B



Source: Ibak, Germany

