

MAIN FEATURES

DUAL FUNCTION AND HIGH PERFORMANCE

- › Dual encoder: Two encoders - one space
- › Standard resolution 16 or 32 detent
- › With or without integrated push button
- › Rotational life: Up to 1'000'000 revolutions
- › Excellent indexing feel with 0.5, 1.0, 1.5, 2.0, 2.5, 3.0, 3.5 or 4.5 Ncm switching torque (remains consistent over life)
- › Gold plated contacts
- › Robust metal housing with metal shaft
- › Body size 11.5 x 12.3 x 9.1 mm
- › Optional front panel sealing IP68
- › Operating temperature range: -40 to +85°C
- › Shaft electrically insulated > 500 VDC (shaft to contact system)
- › Various options and customizations

SWISS CLICK INDEXING SYSTEM™ MIL-STD-202G compliant

TYPE E37

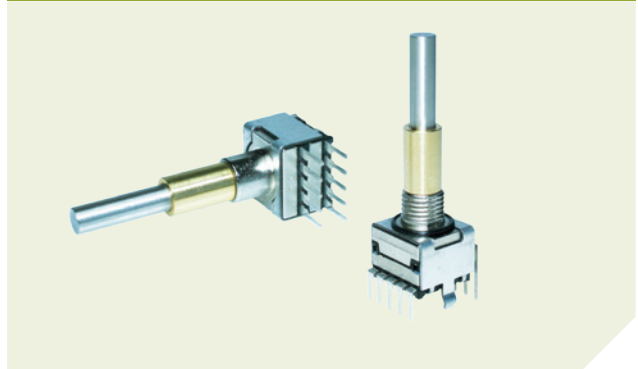

For information about the **SWISS CLICK INDEXING SYSTEM™** see chapter technical explanations

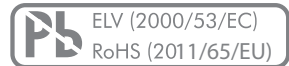

PRODUCT VARIETY

- Vertical or horizontal mounting
- Threaded or non-threaded bushing
- Push button force 6 N or without push button
- detent/pulses per rev. (PPR)
- 32/16, 32/8, 16/16, 16/8
- Switching torque 0.5, 1.0, 1.5, 2.0, 2.5, 3.0, 3.5 or 4.5 Ncm or no detent
- Front panel sealing IP60 or ² IP68

POSSIBLE CUSTOMIZATIONS

- Shaft dimension and shape
- Stainless steel housing
- Switching torque and push button actuation force
- Indexing resolution and PPR

TYPICAL APPLICATIONS

- Cockpit control, radios and navigation
- Desktop and mobile radios
- Professional, portable audio equipment
- Applications where user interface is space critical

1 PREFERENCE TYPES SELECTION CHART

PUSH BUTTON	INNER SHAFT	OUTER SHAFT	IP SEALING	PART NUMBER THT VERTICAL (³ THREADED BUSHING)	PART NUMBER THT HORIZONTAL (³ THREADED BUSHING)
Yes, 6 N	16 detent (8 PPR) 2.5 Ncm	16 detent (8 PPR) 2.5 Ncm	IP60	E37-VT6330-1	E37-CT6330-1
			IP68	E37-VT6332-1	E37-CT6332-1
	32 detent (16 PPR) 2.0 Ncm	IP60	E37-VT6310-1	E37-CT6310-1	
		IP68	E37-VT6312-1	E37-CT6312-1	

RECOMMENDED SYSTEM INTERFACE

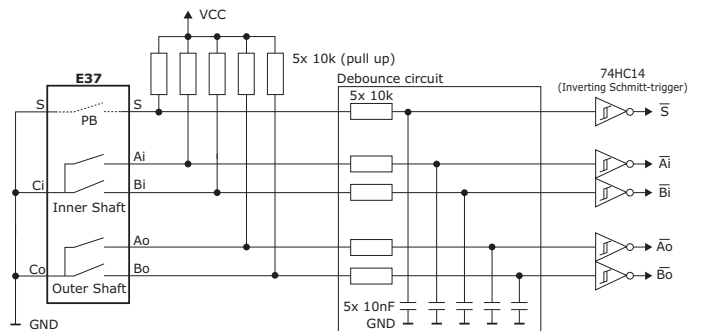

Pin#	1	2	3	4	5
	Bi	S	S	Ci	Ai
	6	7	8	9	10
	Bo	NC	NC	Co	Ao

Timing diagram shows 32/16 (16/8) detents/PPR resolution

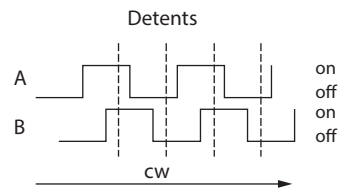
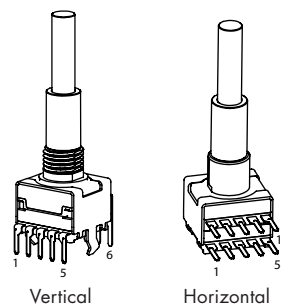

¹ For other types/options, see type key.
² Non-threaded bushing: gasket provides IP65.
³ Nut supplied.

SPECIFICATIONS

MECHANICAL DATA

¹ Inner shaft:	16 detent with 2.5 Ncm or 4.5 Ncm (+/- 30%) or no detent
¹ Outer shaft:	For 32 detent: 0.5, 1.0, 1.5, 2.0 or 3.0 Ncm (+/- 30%) For 16 detent: 0.5, 1.5, 2.5, 3.5 or 4.5 Ncm (+/- 30%)
² Rotational life:	1'000'000 revolutions min. with 0.5, 1.0 or 1.5 Ncm switching torque or with no detent 500'000 revolutions min. with 2.0 Ncm switching torque 300'000 revolutions min. with 2.5 Ncm switching torque 100'000 revolutions min. with 3.0, 3.5 or 4.5 Ncm switching torque
Residual switching torque (end of life):	90% typ.
Shaft strength:	100 N min. push, 100 N min. pull, 50 Ncm min. bending
Fastening torque of nut:	100 Ncm max.

ELECTRICAL DATA

Coding/output:	2-bit quadrature
Resolution:	16 or 8 pulses per revolution (PPR) per channel
Phase shift (A leads B clockwise):	90° (+/- 70°)
Pulse width per channel:	180° (+/- 36°)
Operating speed:	60 RPM max.
Contact bouncing time:	2 ms max.
Contact resistance:	10 Ω max. (over the entire rotational life)
Insulation resistance:	1 GΩ min 500 VDC
Dielectric withstanding voltage to housing/shaft:	500 VDC during 60 seconds (MIL-STD-202G, method 301)

MATERIAL DATA

Shaft:	Outer shaft; brass (CuZn38Pb2), inner shaft; stainless steel (1.4305)
Housing:	Zinc diecast with glossy nickel plating, fiber enforced high performance plastic
Nut:	Brass with glossy nickel plating
Contact system:	Alloy copper, AuCo plated (hard gold)
Soldering leads:	Alloy copper, tin plated
Housing clamp, retention clips:	Tinplate, tin plated
O-rings:	NBR (nitrile), 70 shore
Gasket (non-threaded bushing):	Closed-cell EPDM based rubber, 45 shore A, complies with SAE J 18-79

ENVIRONMENTAL DATA

² Operating temperature range:	-40 to +85°C (IEC 60068-2-14)
Storage temperature range:	-65 to +125°C (IEC 60068-2-14, MIL-STD202G, method 107G, condition B-3)
Humidity (non condensing):	93% RH max. (MIL-STD-202G, method 103B, condition B)
IP sealing:	IP60, optional IP68 (2 bar, 1h) shaft/front panel sealing (non-threaded bushing; gasket provides IP65)
Vibration:	29 G _{rms} max. @ 100 to 1000 Hz (MIL-STD-202G, method 214A, condition 1H/15 minutes)
Shock:	100 G max. (MIL-STD-202G, method 213B, condition C)
Flammability:	UL94-V0 (IP65/IP68: O-rings and non-threaded bushing gasket are UL94-HB)

PACKAGING QUANTITY

Tray:	20 pcs. (nuts are supplied and packed separately)
-------	---

ADDITIONAL DATA FOR PUSH BUTTON SWITCH

MECHANICAL DATA

Push button actuation force (new condition):	3, 6, 10, 14 N (+/- 30%) or without push button force
Push button switch travel:	0.5 (+/- 0.2) mm
² Push button switch life:	200,000 actuations min.
Residual push button actuation force (end of life):	90% typ.

ELECTRICAL DATA

Contact bouncing time:	2 ms max.
Dielectric withstanding voltage to housing/shaft:	500 VDC during 60 seconds (MIL-STD-202G, method 301)

MATERIAL DATA

Contact pads:	Alloy copper, AuCo plated (hard gold)
Membrane switch:	Stainless steel, AuCo plated (hard gold)

SOLDERING CONDITIONS

Hand soldering:	300°C max. during 3 sec max.
Wave soldering:	280°C max. peak temperature during 5 sec max.
Reflow soldering is not applicable!	

¹ O-ring of IP65/IP68 shaft sealing may slightly increase switching torque.

² Rotational/actuation life is tested at room condition (+25°C, 50 to 60% RH).

Operating speed is 60 RPM (encoder) and 2 Hz (push button). Different operating conditions may decrease life expectation dramatically.

DRAWINGS

Tolerances unless otherwise specified DIN ISO 2768-1 (m)

THT VERTICAL

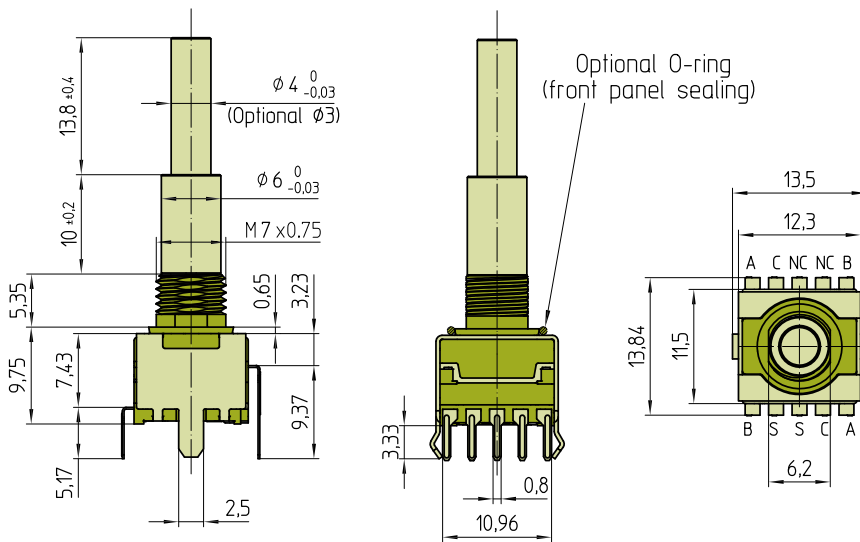

DRILLING DIAGRAM

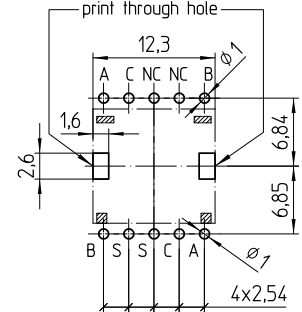

PCB-thickness: 1 - 1.5 mm

View from component side of the PCB

Both threaded and non-threaded bushings are available for all versions; THT vertical or THT horizontal (see type key).

THT HORIZONTAL

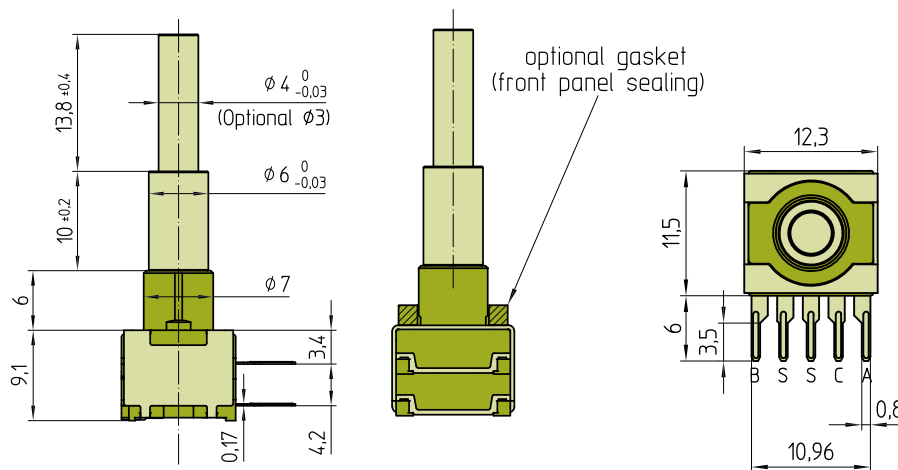

DRILLING DIAGRAM

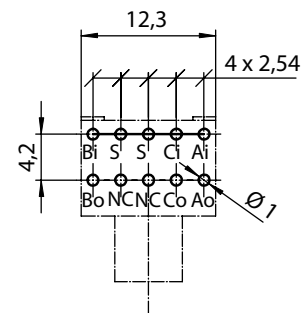

PCB-thickness: 1 - 1.5 mm

View from component side of the PCB

Both threaded and non-threaded bushings are available for all versions; THT vertical or THT horizontal (see type key).

DRAWINGS

NUT

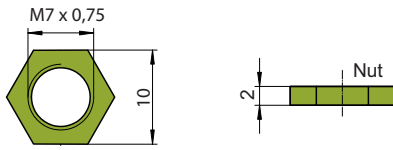

Spare Part
Part Number (50 pcs. bag)
- Brass nickel plated: 4516-40

FRONT PANEL CUT OUT

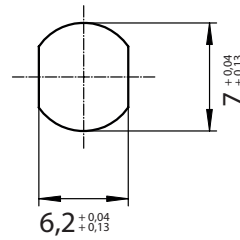

RECOMMENDED KNOBS



TYPE 1 - SOFT TOUCH COLLETS; 15/21 mm (FOR SHAFT TYPE Ø 4mm)

Inner shaft	Cap	15 mm black, glossy	K51-C150-01
	Knob	15 mm, soft touch, collet	K60-S150-004
Outer shaft	Knob	21 mm, soft touch, collet	K60-S210-006

Also see Rotary Switches main catalog; page 127 (soft touch collet knobs; K60 series).



TYPE 2 - CLASSIC COLLETS; 10/14.5 mm (FOR SHAFT TYPE Ø 3mm)

Inner shaft	Cap	10 mm black	040-1020
	Knob	10 mm, classic collet	020-2120
Outer shaft	Knob	14,5 mm, classic collet	020-3440

Also see Rotary Switches main catalog; page 116-119 (classic collet knobs).



TYPE 3 - METAL KNOBS; 11/15 mm (FOR SHAFT TYPE Ø 4mm)

Inner shaft	11 mm, metal
Outer shaft	15 mm, metal

2 pc sets:

Silver: CAE041559

Black: CAE041560

TYPE KEY

E 37	-	-	-	-	-	-	-	-	-
-------------	---	---	---	---	---	---	---	---	---

ORIENTATION/MOUNTING

- V** THT vertical
- C** THT horizontal

BUSHING

- T** Threaded M7 x 0.75 x 6 mm (nut supplied, packed separately)
- N** Non-threaded Ø 7 x 6 mm

PUSH BUTTON

- 6** 6 N
- 0** Without push button
- 4 A** 10 N
- 4 E** 14 N
- 4** Available beginning 2015

1 INNER SHAFT RESOLUTION; TORQUE

3	16 detent	(8 PPR)	2.5 Ncm
6	16 detent	(16 PPR)	2.5 Ncm
8	No detent	(16 PPR)	
9	No detent	(8 PPR)	
G	16 detent	(8 PPR)	4.5 Ncm

¹ O-ring of IP65/IP68 shaft sealing may slightly increase switching torque.

1 OUTER SHAFT RESOLUTION, TORQUE

1	32 detent	(16 PPR)	2.0 Ncm
2	16 detent	(8 PPR)	1.5 Ncm
3	16 detent	(8 PPR)	2.5 Ncm
4	32 detent	(8 PPR)	2.0 Ncm
5	16 detent	(16 PPR)	1.5 Ncm
6	16 detent	(16 PPR)	2.5 Ncm
8	No detent	(16 PPR)	
9	No detent	(8 PPR)	
A	32 detent	(16 PPR)	0.5 Ncm
3 B	32 detent	(16 PPR)	1.0 Ncm
2 C	32 detent	(16 PPR)	1.5 Ncm
2 D	32 detent	(16 PPR)	3.0 Ncm
2 E	16 detent	(8 PPR)	0.5 Ncm
2 F	16 detent	(8 PPR)	3.5 Ncm
G	16 detent	(8 PPR)	4.5 Ncm

¹ O-ring of IP65/IP68 shaft sealing may slightly increase switching torque.
² Available in beginning 2015
³ Available with non-threaded bushing only.

SHAFT TYPE

- 1** Basic type (see drawing)
- 2** Inner shaft; Ø 3.0 mm, same length as basic type

IP SEALING

- 0** IP60
- 1 1** IP68 shaft sealing
- 1 2** IP68 shaft/front panel sealing (non-threaded bushing gasket provides IP65, O-ring/gasket is mounted)

¹ O-ring of IP65/IP68 shaft sealing may slightly increase switching torque.

O-RING MOUNTING TOOL



Part Number: E33-ORING-TOOL

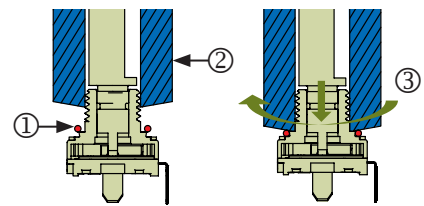

- ① Slip the lubricated O-ring over the bushing.
- ② Slide the mounting tool over the bushing.
- ③ While pushing down the O-ring simultaneously rotate the mounting tool.