



More Precision

wireSENSOR // Draw-wire displacement sensors





- Measuring ranges up to 50,000mm
- Resolution towards infinity
- Compact overall design
- Easy mounting for any application
- High reliability and long life cycle
- Analog and digital outputs

Principle

Draw-wire displacement sensors measure linear movements using a highly flexible steel cable. The cable drum is attached to a sensor element which provides a proportional output signal. Measurements are performed with high accuracy and high dynamic response. The use of high quality components guarantees a long life cycle and high operational reliability.

MICRO-EPSILON offers a large range of draw-wire displacement sensors equipped with different output signal types and

therefore the ideal sensor for any customer-specific application. We also develop and produce individual OEM models for special applications involving high volumes. The wire-SENSOR models stand out due to an optimal measuring range/size ratio as well as easy installation and handling. The rugged sensor construction ensures reliable operation even under difficult ambient conditions.

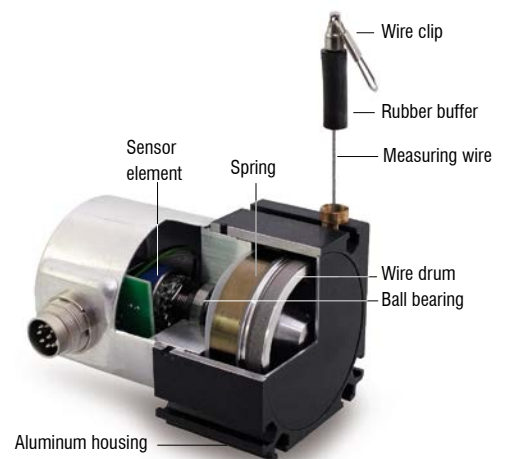

Sensor design WDS-P60

Available sensor series



wireSENSOR MK30/MK46/MK77/MK60/MK88/MK120



wireSENSOR MPM/MPW



wireSENSOR P60/P96



wireSENSOR P115



wireSENSOR P200



wireSENSOR mechanics

Model	Measuring range (mm)																				Page							
	50	100	150	250	300	500	750	1000	1250	1500	2000	2100	2300	2400	2500	3000	3500	4000	5000	7500		10.000	15.000	30.000	40.000	50.000		
MK30 analog	P		P	P		P	P																					6-7
MK30 digital						E	E																					8-9
MK46 analog								P																				10-11
MK46 digital										E																		12-13
MK 77 analog																												14-15
MK 77 digital																												16-17
MK 60 analog																												18-19
MK 60 digital																												20-21
MK 88 analog																												22-23
MK 120 analog																												24-25
MPM analog	P		P	P																								26-27
MP/MPW analog		P			P	P		P																				28-29
P60 analog		P	P		P	P	P	P																				30-31
P60 digital																												32-33
P96 analog																												34-35
P96 digital																												36-37
P115 analog																												38-39
P115 digital																												40-41
P200 digital																												42-43
Mechanics																												44-49

P Voltage
 I Current
 E Incremental encoder
 A Absolute encoder
 M Mechanics



Positioning of catering trucks at Airbus A380



Positioning of operating tables



Variable support for mobile cranes and cherry picker platforms



Release of satellites into space



Displacement measurement on slag transporter



Position measurement on X-ray machines



Lift-height measurement in fork-lift trucks



Height of lifting platforms on automobile production lines



- Robust plastic housing
- Customized versions for OEM
- Conductive plastic/wire/
hybrid potentiometer
- Smallest design in its class

Model MK30-P (Measuring range 50mm)

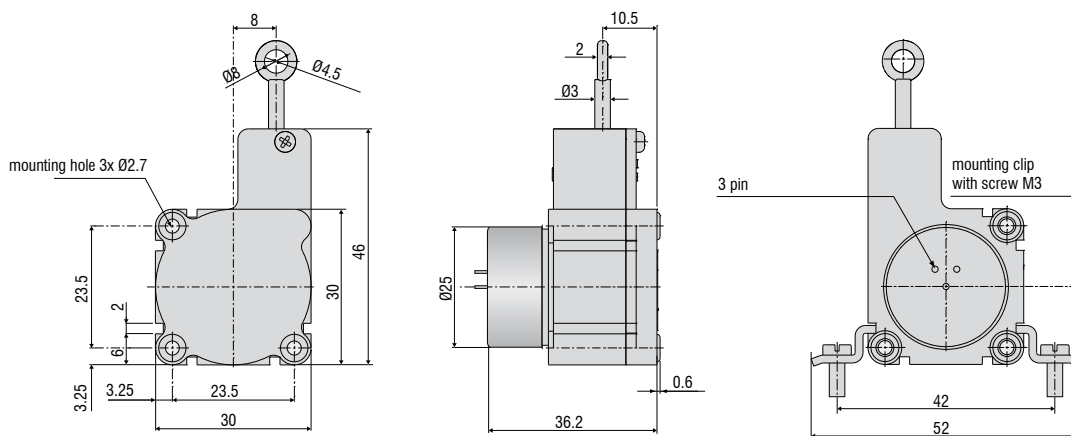

Model MK30-P (Measuring range 150/250/500/750mm)

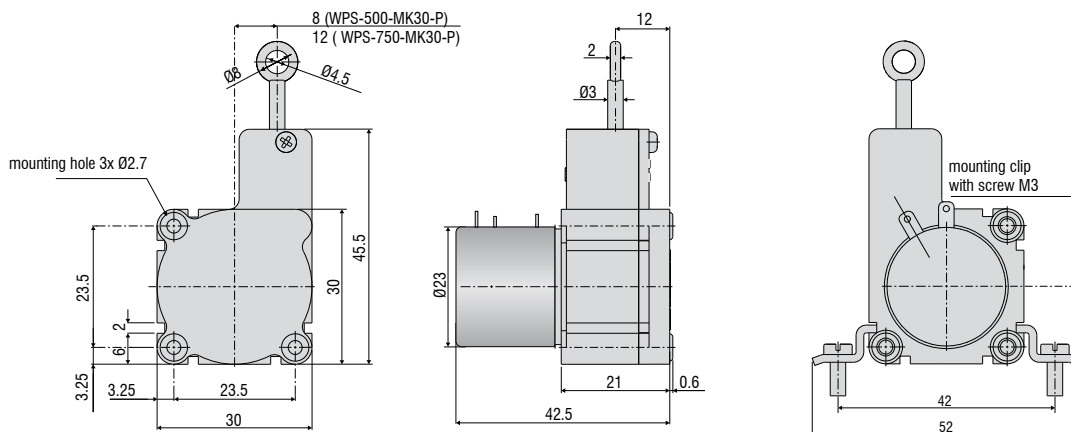

Model		WPS-50-MK30	WPS-150-MK30	WPS-250-MK30	WPS-500-MK30	WPS-750-MK30
Output		P				
Measuring range		50mm	150mm	250mm	500mm	750mm
Linearity	conductive plastic pot.	±0.5% FSO	±0.25mm	-	-	-
	wire pot. P25	±0.25% FSO	-	-	-	±1.25mm
	hybrid pot. P25	±0.25% FSO	-	±0.375mm	±0.625mm	-
	hybrid pot. P25	±0.1% FSO	-	-	±0.25mm	±0.5mm
Resolution	conductive plastic pot.					towards infinity
	wire pot.	-	0.1mm	0.1mm	0.15mm	0.2mm
	hybrid pot.					towards infinity
		conductive plastic/wire/hybrid potentiometer				
Temperature range		-20 °C ... +80 °C				
Material	housing	plastic				
	draw-wire	coated polyamide stainless steel (ø 0.36mm)				
Wire mounting		eyelet				
Sensor mounting		mounting holes / mounting grooves				
Wire acceleration		approx. 5g				
Wire retraction force (min)		approx. 1N				
Wire extension force (max)		approx. 2.5N				
Protection class		IP20				
Electrical connection		soldering tag				
Weight		appr 45g				

FSO = Full Scale Output

Specifications for analog outputs on page 51.

Article description

WPS -	50 -	MK30 -	P25	
				Output option: potentiometer P50 (Linearity ±0.5% FSO) potentiometer P25 (Linearity ±0.25% FSO) potentiometer P10 (Linearity ±0.1% FSO)
				Model MK30
				Measuring range in mm



- Robust plastic housing
- Customized versions for OEM
- Smallest design in its class
- Incremental encoder

Model MK30

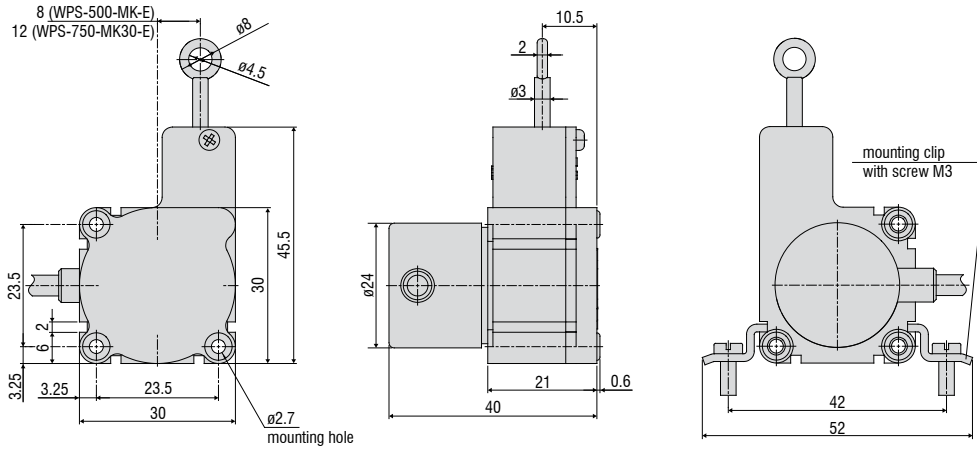

Model	WPS-500-MK30	WPS-750-MK30
Output	E/E830	E/E830
Measuring range	500mm	750mm
Linearity E $\pm 0.05\%$ FSO	$\pm 0.25\text{mm}$	$\pm 0.375\text{mm}$
Resolution	10 pulses/mm	6.7 pulses/mm
	0.1mm	0.15mm
Sensor element	incremental encoder	
Temperature range	-20 °C ... +80 °C	
Material	housing	plastic
	draw-wire	coated polyamide stainless steel ($\varnothing 0.36\text{mm}$)
Wire mounting	eyelet	
Sensor mounting	mounting holes / mounting grooves	
Wire acceleration	approx. 5g	
Wire retraction force (min)	approx. 1N	
Wire extension force (max)	approx. 2.5N	
Protection class	IP54	
Electrical connection	cable radial, 1m	
Weight	approx. 80g	

FSO = Full Scale Output
 Specifications for digital outputs on page 52.

Article description

WPS -	500 -	MK30 -	E830
			Output option: encoder E (5 ... 24 VDC) encoder E830 (8 ... 30 VDC)
			Model MK30
			Measuring range in mm



- Robust plastic housing
- Customized versions for OEM
- Wire/hybrid potentiometer

Model MK46 Output P10/P25

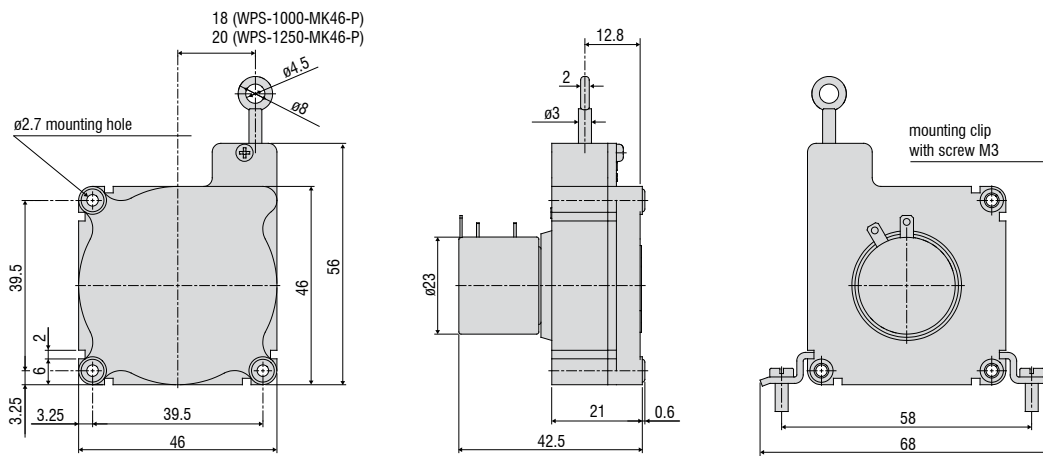

Model MK46 Output CR-P25/CR-U10/CR-I10

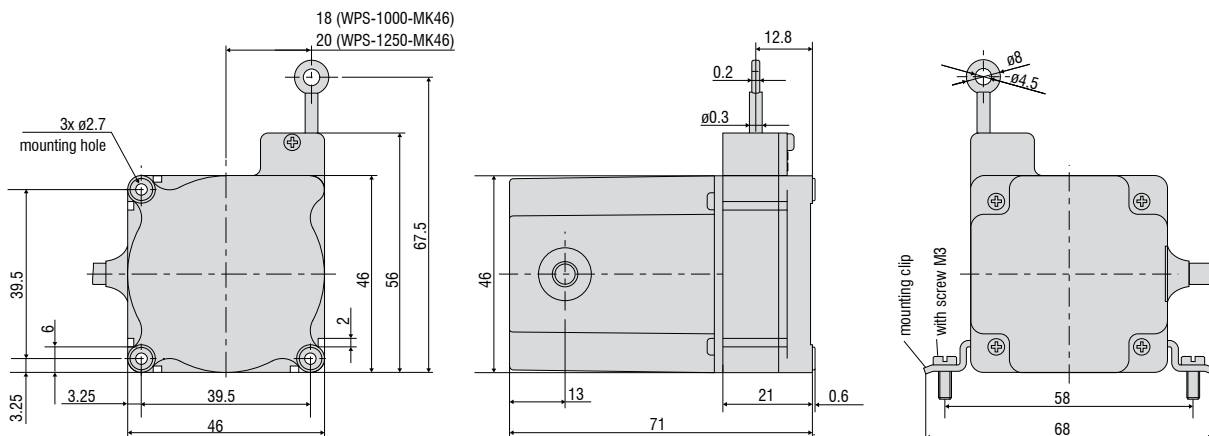

Model	WPS-1000-MK46		WPS-1250-MK46	
Output	P		P/U/I	
Measuring range	1000mm		1250mm	
Linearity	wire pot. P25	±0.25% FSO	±2.5mm	±3.12mm
	Hybridpot. P10/U10/I10	±0.1% FSO	±1mm	±1.2mm
Resolution	wire pot. P25	0.3mm	0.4mm	
	Hybridpot. P10/U10/I10	towards infinity		
Sensor element	wire/hybrid potentiometer			
Temperature range	-20 °C ... +80 °C			
Material	housing	plastic		
	draw-wire	coated polyamide stainless steel (ø 0.36mm)		
Wire mounting	eyelet			
Sensor mounting	mounting holes / mounting grooves			
Wire acceleration	approx. 5g			
Wire retraction force (min)	approx. 1N			
Wire extension force (max)	1.6N		1.5N	
Protection class	IP20			
Electrical connection	P10, P25	soldering tag		
	CR-P25/CR-U10/ CR-I10	integrated cable, radial, 1m		
Weight	approx. 80g			

FSO = Full Scale Output

Specifications for analog outputs on page 51.

Article description

WPS - 1000 - MK46 - P25

Output option:
P25: potentiometer
P10: potentiometer
CR-P25: potentiometer, integrated cable, radial, 1m

Model MK46

Measuring range in mm

WPS - 1250 - MK46 - P25

Output option:
P25: potentiometer
P10: potentiometer
CR-P25: potentiometer, integrated cable, radial, 1m
CR-U10: voltage, integrated cable, radial, 1m
CR-I10: current, integrated cable, radial, 1m

Model MK46

Measuring range in mm



- Robust plastic housing
- Customized versions for OEM
- Incremental encoder

Model MK46

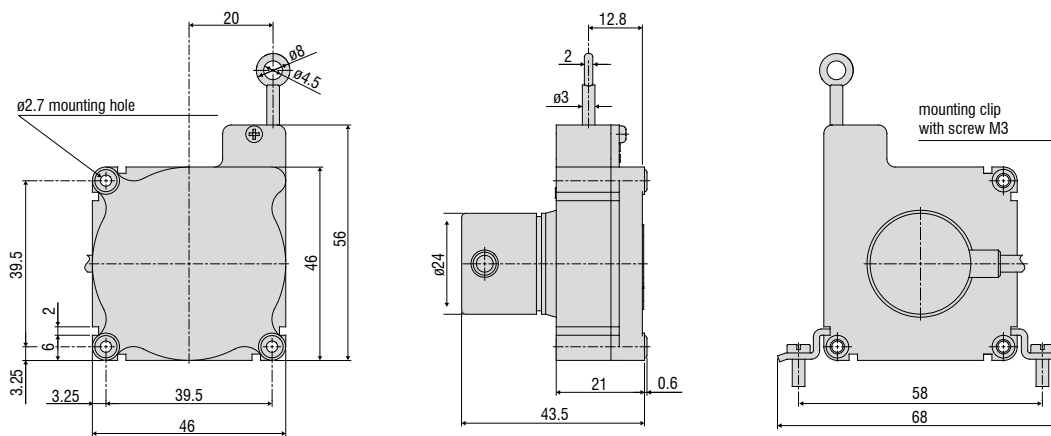

Model	WPS-1250-MK46	
Output	E/E830	
Measuring range	1250mm	
Linearity	±0.05% FSO	encoder
Resolution	4 pulses/mm	
	0.25mm	
Sensor element	incremental encoder	
Temperature range	-20 °C ... +80 °C	
Material	housing	plastic
	draw-wire	coated polyamide stainless steel (ø 0.36mm)
Wire mounting	eyelet	
Sensor mounting	mounting holes / mounting grooves	
Wire acceleration	approx. 5g	
Wire retraction force (min)	approx. 1N	
Wire extension force (max)	1.5N	
Protection class	IP54	
Electrical connection	cable radial, 1m	
Weight	approx. 120g	

FSO = Full Scale Output

Specifications for digital outputs on page 52.

Article description

WPS -	1250 -	MK46 -	E
			Output option: encoder E (5 ... 24 VDC) encoder E830 (8 ... 30 VDC)
			Model MK46
			Measuring range in mm



- Robust plastic housing
- Customized versions for OEM
- Wire potentiometer

Model MK77 Output P25

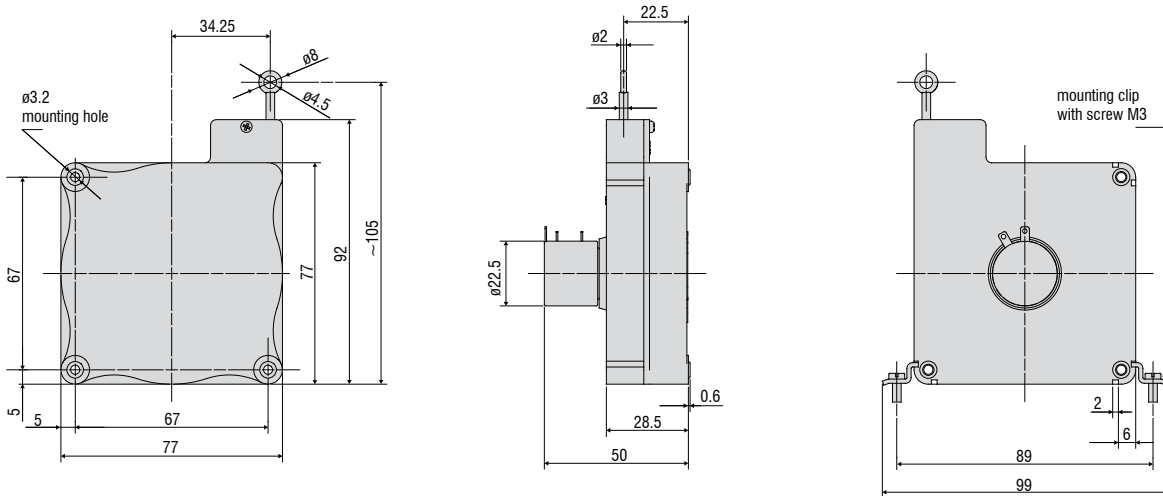

Model MK77 Output CR-P25

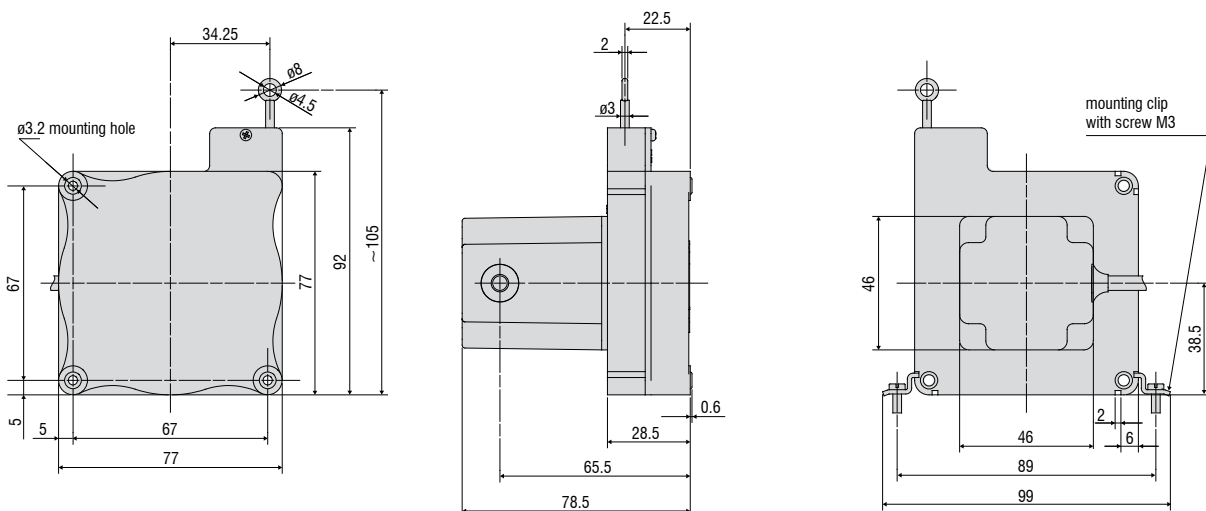

Model	WPS-2100-MK77	
Output	P25	
Measuring range	2100mm	
Linearity	wire pot. $\pm 0.25\%$ FSO	$\pm 5.25\text{mm}$
Resolution	wire pot.	0.55mm
Sensor element	wire potentiometer	
Temperature range	$-20\text{ }^{\circ}\text{C} \dots +80\text{ }^{\circ}\text{C}$	
Material	housing	plastic
	draw-wire	coated polyamide stainless steel ($\varnothing 0.45\text{mm}$)
Wire mounting	eyelet	
Sensor mounting	mounting holes / mounting grooves	
Wire retraction force (min)	3.5N	
Wire extension force (max)	5N	
Wire acceleration (max)	5g	
Protection class	IP20	
Electrical connection	P25	soldering tag
	CR-P25	integrated cable radial, 1m
Weight	P25	approx. 0.2kg
	CR-P25	approx. 0.25kg

FSO = Full Scale Output
 Specifications for analog outputs on page 51.

Article description

WPS -	2100 -	MK77 -	P25
			Output option: potentiometer P25 (Linearity $\pm 0.25\%$ FSO) potentiometer CR-P25, integrated cable, radial, 1m
			Model MK77
			Measuring range in mm



- Robust plastic housing
- Customized versions for OEM
- Incremental/absolute encoder

Model MK77

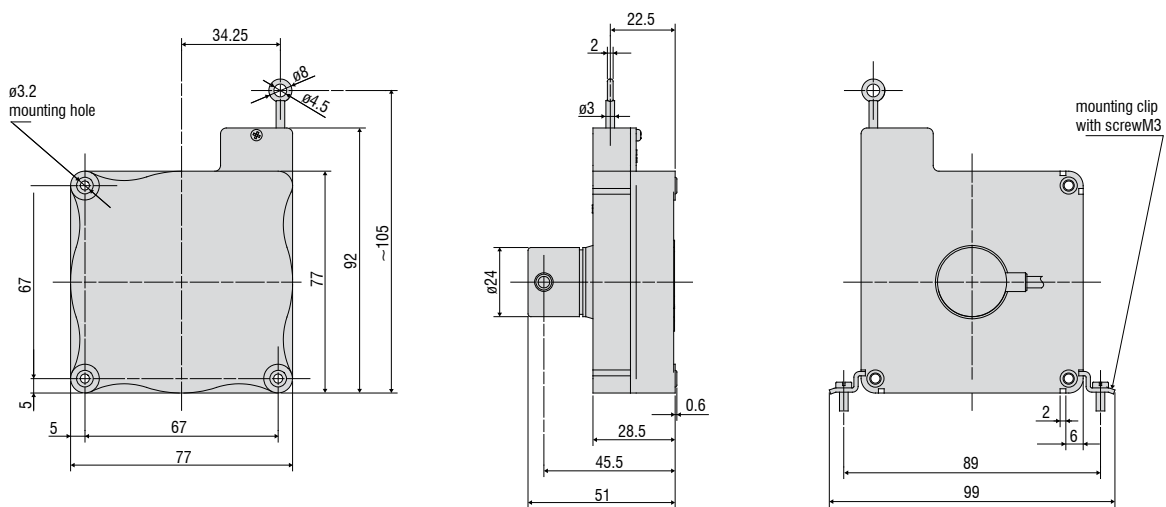

Model	WPS-2100-MK77	
Output	E/ E830	
Measuring range	2100mm	
Linearity	±0.05% FSO	±1.05mm
Resolution	0.43mm	
Sensor element	incremental encoder	
Temperature range	-20 °C ... +80 °C	
Material	housing	plastic
	draw-wire	coated polyamide stainless steel (ø 0.45mm)
Wire mounting	eyelet	
Sensor mounting	mounting holes / mounting grooves	
Wire retraction force (min)	3.5N	
Wire extension force (max)	5N	
Wire acceleration (max)	5g	
Protection class	IP54	
Electrical connection	cable radial, 2m	
Weight	approx. 0.27kg	

FSO = Full Scale Output
 Specifications for digital outputs on page 52.

Article description

WPS -	2100 -	MK77 -	E
			Output option: encoder E (5 ... 24 VDC) encoder E830 (8 ... 30 VDC)
			Model MK77
			Measuring range in mm



- Robust plastic housing
- Customized versions for OEM
- Potentiometer, current and voltage output

Model MK60

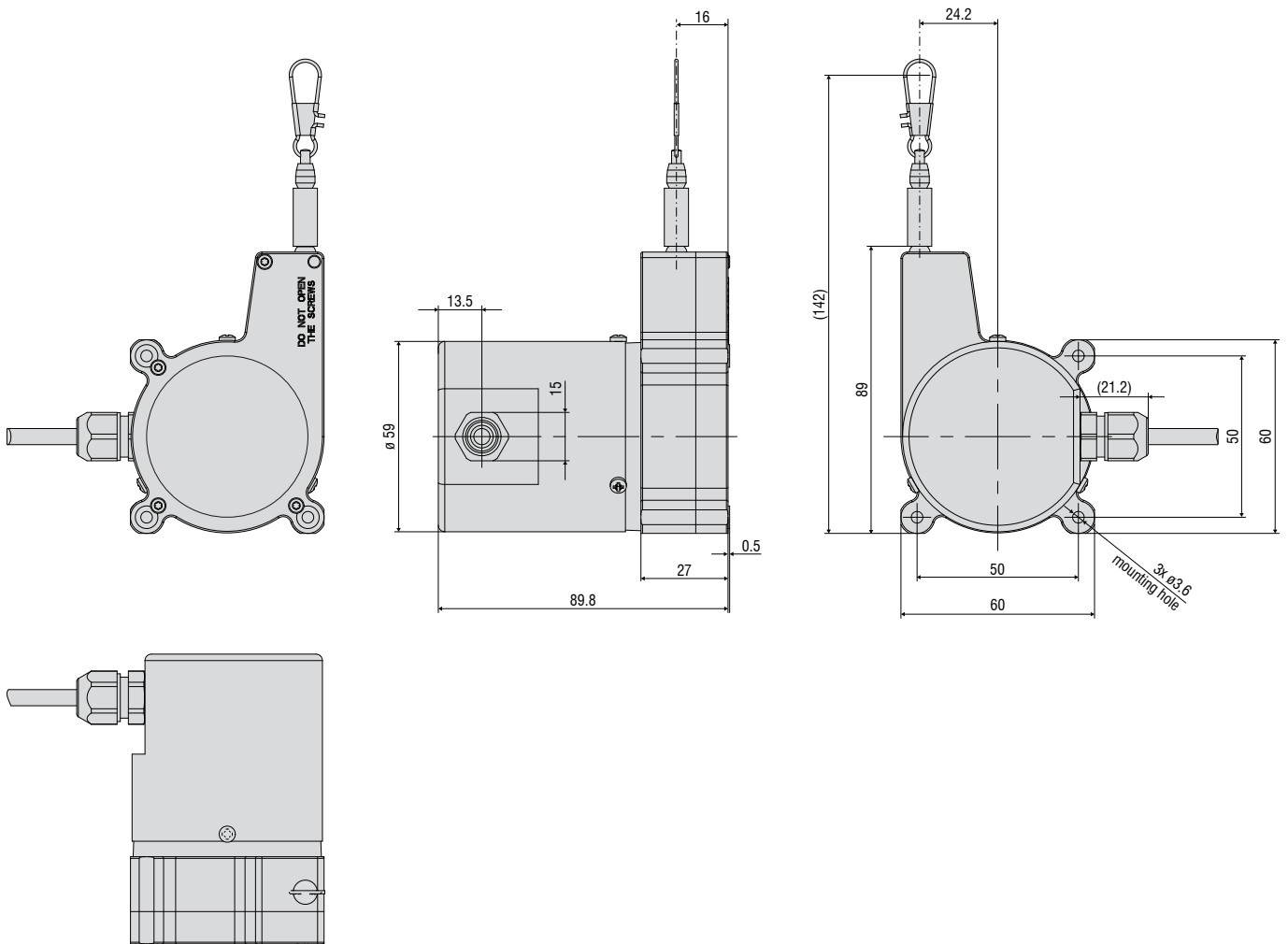

Model	WPS-1500-MK60	
Output	P/U/I	
Sensor element	potentiometer	
Measuring range	1500mm	
Linearity	±0.15% FSO	
Resolution/Sensitivity	towards infinity	
Temperature range	-20 °C ... +80 °C	
Material	housing	plastic, PBT GF20
	draw-wire	coated polyamide stainless steel (ø 0.45mm)
	protection cap	plastic, PBT GF20
Wire mounting	wire clip	
Sensor mounting	mounting holes on the sensor housing	
Wire retraction force (min)	1N	
Wire extension force (max)	8N	
Wire acceleration (max)	5g	
Protection class	IP65	
Electrical connection	cable, radial, 1m	
Weight (with cable)	290g	

FSO = Full Scale Output

Specifications for analog outputs on page 51.

Article description

WPS -	1500 -	MK60 -	CR -	P
				Output option: P: potentiometer U: voltage I: current
			Connection CR: integrated cable, radial, 1m	
		Model MK60		
Measuring range in mm				



- Robust plastic housing
- Customized versions for OEM
- Incremental encoder

Model MK60

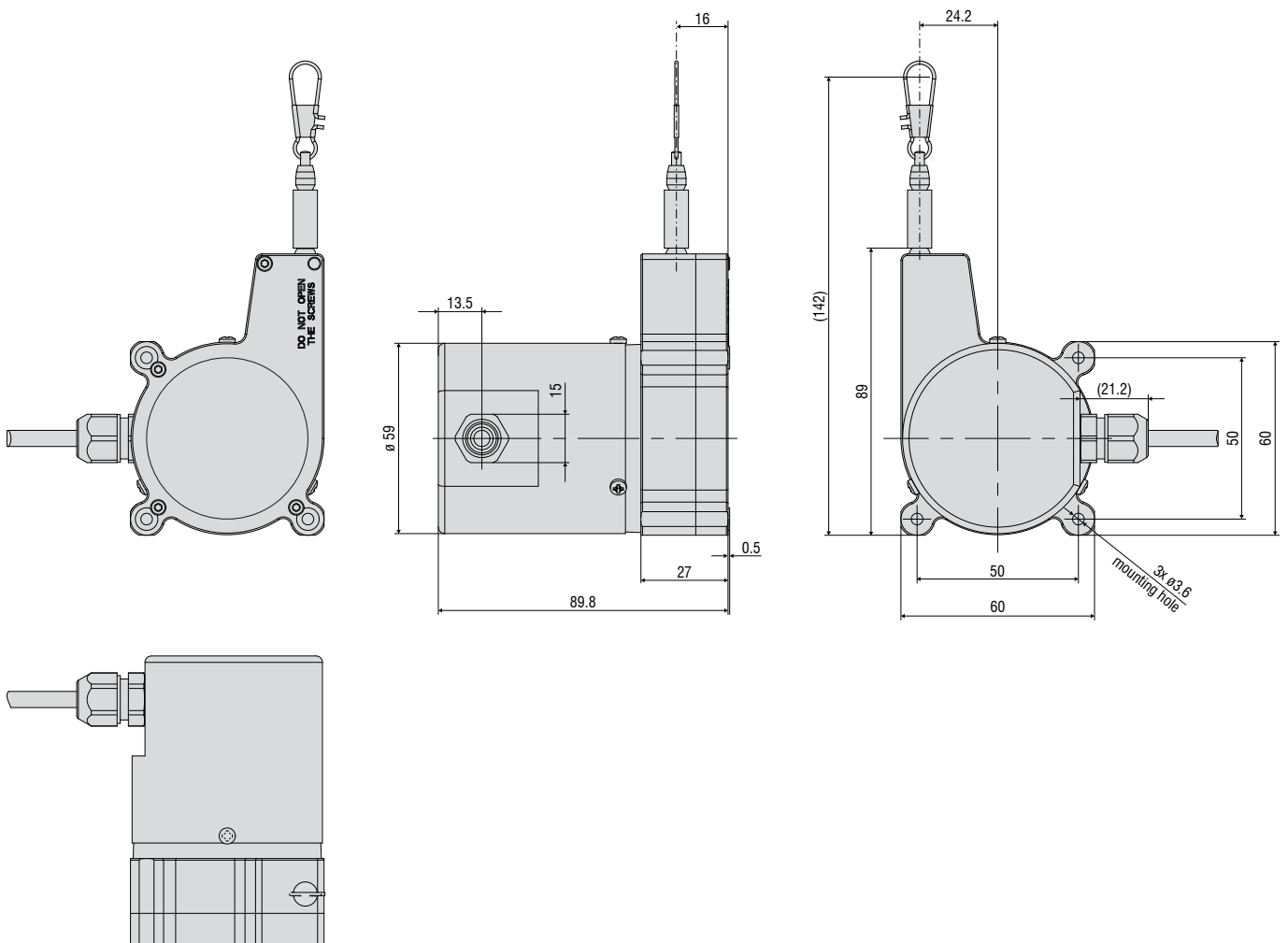

Model	WPS-2400-MK60-CR	
Output	TTL01	TTL02
Signals	A, B, 0	A, \bar{A} , B, \bar{B} , O
Sensor element	incremental encoder	
Measuring range	2400mm	
Linearity	$\pm 0.05\%$ FSO	
Resolution	6.83 pulses/mm	
Temperature range	-20 °C ... +80 °C	
Material	housing	plastic, PBT GF20
	draw-wire	coated polyamide stainless steel (\varnothing 0.45mm)
	protection cap	plastic, PBT GF20
Wire mounting	wire clip	
Sensor mounting	mounting holes on the sensor housing	
Wire retraction force (min)	1N	
Wire extension force (max)	8N	
Wire acceleration (max)	5g	
Protection class	IP65	
Electrical connection	cable, radial, 1m	
Weight (with cable)	~290g	

FSO = Full Scale Output
 Specifications for digital outputs on page 52.

Article description

WPS -	2400	MK60 -	CR -	TTL01
				Output option: TTL01: A, \bar{B} , 0 TTL02: A, \bar{A} , B, \bar{B} , O
				Connection CR: integrated cable, radial, 1m
				Model MK60
				Measuring range in mm



- Robust plastic housing
- Customized versions for OEM
- Potentiometer, current and voltage output

Model MK88

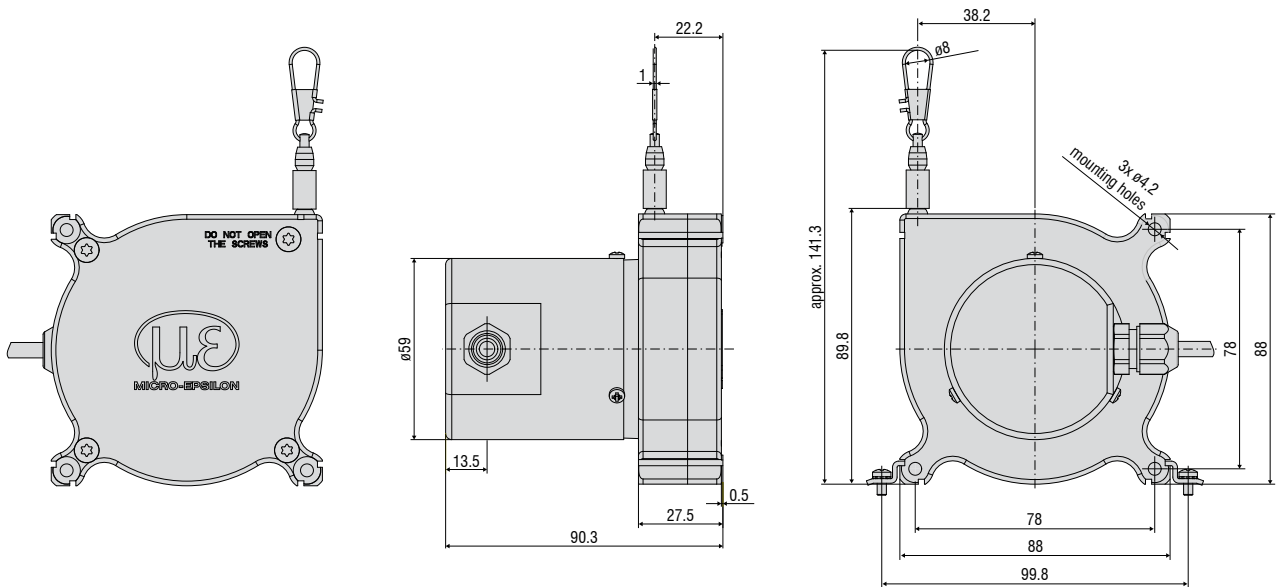

Model	WPS-2300-MK88	WPS-3500-MK88	WPS-5000-MK88
Output	P/U/I		
Sensor element	potentiometer		
Measuring range	2300mm	3500mm	5000mm
Linearity	±0.15% FSO	±0.3% FSO	±0.4% FSO
Resolution/Sensitivity	towards infinity		
Temperature range	-20 °C ... +80 °C		
Material	housing	plastic, PA 6 GF 30	
	draw-wire	coated polyamide stainless steel (ø 0.45mm)	
	protection cap	plastic, PBT GF 20	
Wire mounting	wire clip		
Sensor mounting	mounting holes / mounting grooves on the sensor housing		
Wire retraction force (min)	4N		
Wire extension force (max)	9N		
Wire acceleration (max)	approx. 7g		
Protection class	IP65		
Electrical connection	cable, radial, 1m		
Weight (with cable)	400-430g		

FSO = Full Scale Output

Specifications for analog outputs on page 51.

Article description

WPS -	2300 -	MK88 -	CR -	P
				Output option: P: potentiometer U: voltage I: current
			Connection CR: integrated cable, radial, 1m	
		Model MK88		
Measuring range in mm				



- Robust plastic housing
- Customized versions for OEM
- Potentiometer, current and voltage output

Model MK120 (Measuring range 3000, 5000mm)

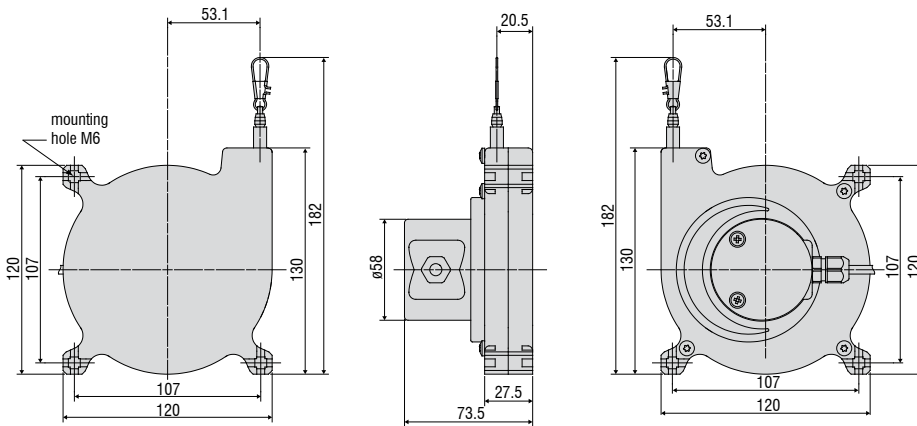

Model MK120 (Measuring range 7500mm)

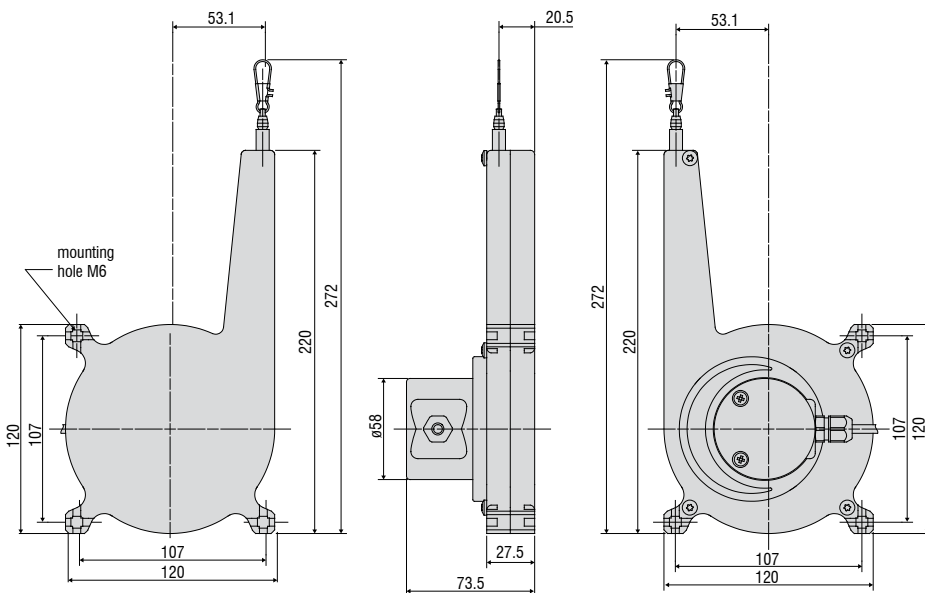

Model	WPS-3000-MK120	WPS-5000-MK120	WPS-7500-MK120
Output	P, U, I		
Measuring range	3000mm	5000mm	7500mm
Linearity	$\pm 0.15\%$ FSO	$\pm 4.5\text{mm}$	$\pm 7.5\text{mm}$
Resolution	towards infinity		
Temperature range	$-20\text{ }^{\circ}\text{C} \dots +80\text{ }^{\circ}\text{C}$		
Material	housing	plastic PA6	
	draw-wire	coated polyamide stainless steel ($\varnothing 0.45\text{mm}$)	
Wire mounting	wire clip		
Wire acceleration		2.5g	1.5g
Wire retraction force (min)	5.5N	5N	7N
Wire extension force (max)		8N	13N
Electrical connection	integrated cable, radial, 1m		
Protection class	IP65		
Weight	0.75kg		0.9kg

FSO = Full Scale Output

Specifications for analog outputs on page 51.

Article description

WPS -	3000 -	MK120 -	CR -	P
				Output option: P: potentiometer U: voltage I: current
			Connection CR: integrated cable, radial, 1m	
		Model MK120		
Measuring range in mm				

- Extreme compact miniature sensor
- Flexible mounting via swivel flange
- High speed measurement, wire acceleration up to 100g



Model MPM

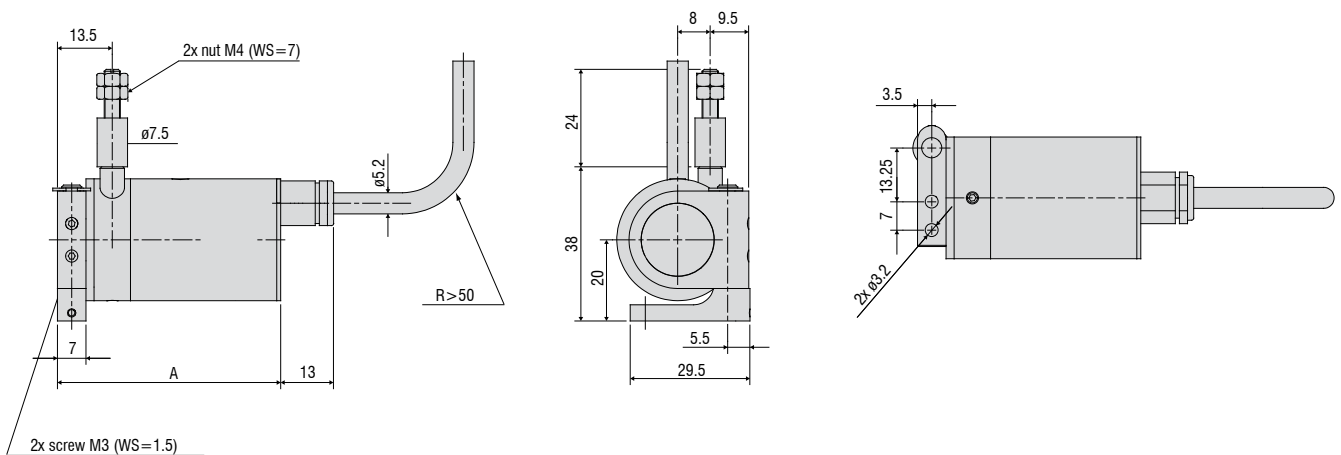

Measuring range (mm)	A (mm)
50	55
150 / 250	64
50-HG	61
150 / 250-HG	70

Model	WDS-50-MPM	WDS-150-MPM	WDS-250-MPM
Output	P		
Measuring range	50mm	150mm	250mm
Linearity	±0.2% FSO	-	±0.5mm
	±0.25% FSO	±0.125mm	-
Resolution	towards infinity		
Sensor element	conductive plastic potentiometer	hybrid potentiometer	
Temperature range	-20 °C ... +80 °C		
Material	housing	aluminum	
	draw-wire	stainless steel (ø 0.45mm)	
Sensor mounting	swivel flange in two axes 180° / 360°		
Wire mounting	thread M4		
Wire acceleration	approx. 25g (option HG: 100g)		
Wire retraction force (min)	1.5N (option HG: 10N)		
Wire extension force (max)	3.5N (option HG: 17N)		
Protection class	IP65		
Vibration	20g, 20Hz - 2kHz		
Mechanical shock	50g, 20ms		
Electrical connection	integrated cable, axial, 3-leads, 1m		
Weight	approx. 150g		

FSO = Full Scale Output
 Specifications for analog outputs on page 51.

Article description

WDS -	50 -	MPM -	C -	P -	HG
					Option HG: wire acceleration up to 100g
					Output option: P: potentiometer
					Connection: C: integrated cable, axial, 1m
					Model MPM
					Measuring range in mm



- Miniature design
- Optional IP67 (MPW)
- For fast measurement and harsh environments

Model MP / MPW

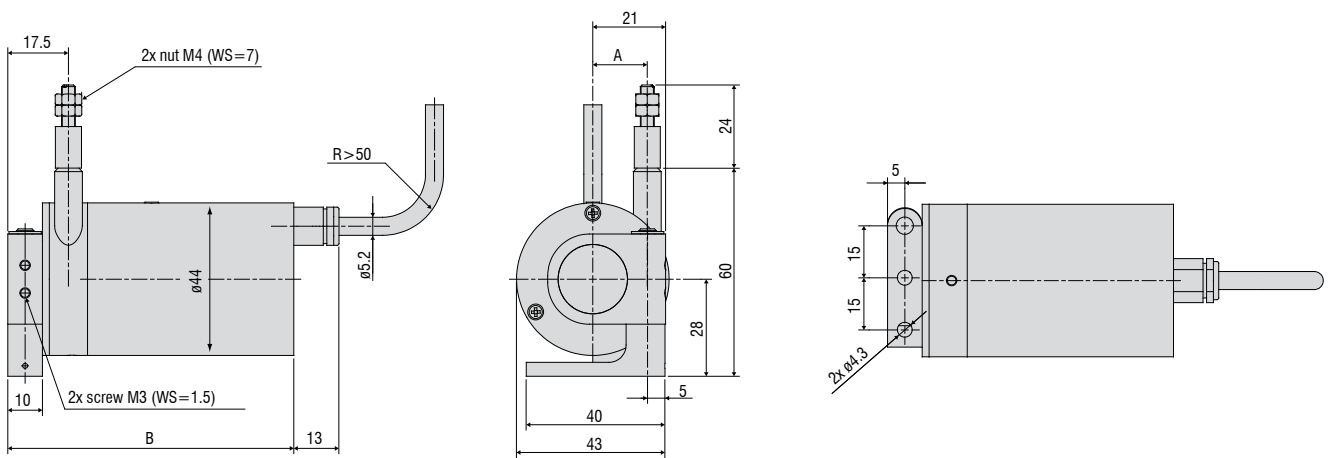

Measuring range (mm)	A (mm)	B (mm)
100 / 300 / 500 / 1000-MP	15.7	82.5
100 / 300 / 500 / 1000-MPW	15.7	86.5

Model	WDS-100 MP(W)	WDS-300 MP(W)	WDS-500 MP(W)	WDS-1000 MP(W)
Output	P			
Measuring range	100mm	300mm	500mm	1000mm
Linearity	±0.1% FSO	-	±0.5mm	±1mm
	±0.25% FSO	-	±0.75mm	-
	±0.5% FSO	±0.5mm	-	-
Resolution	0.15mm	0.2mm	towards infinity	
Sensor element	wire potentiometer		hybrid potentiometer	
Temperature range	-20 °C ... +80 °C			
Material	housing	aluminum		
	draw-wire	stainless steel (ø 0.45mm)		
Wire mounting	thread M4			
Sensor mounting	swivel flange in two axes 180° / 360°			
Wire acceleration	approx. 30g			
Wire retraction force (min)	7N	7N	6.5N	5N
Wire extension force (max)	8.5N	8.5N	8.5N	8N
Protection class	series MP	IP65		
	series MPW	IP67		
Vibration	20g, 20Hz - 2kHz			
Mechanical shock	50g, 10ms			
Electrical connection	integrated cable, axial, 3-leads, 1m			
Weight	approx. 270g			

FSO = Full Scale Output
 Specifications for analog outputs on page 51.

Article description

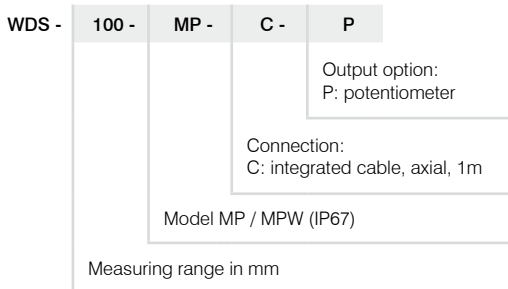



- Robust aluminum profile housing
- Customized versions for OEM
- Potentiometer, current and voltage output

Model P60 Output P

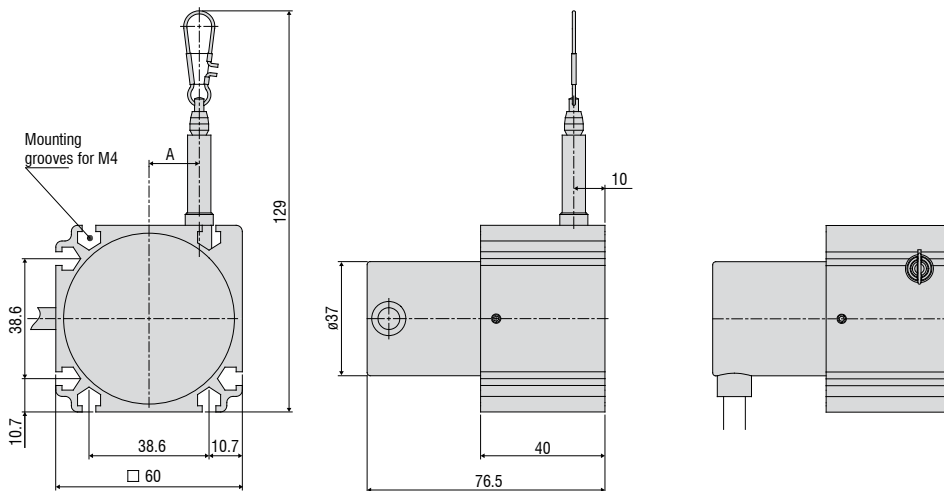

Measuring range (mm)	A (mm)
100 / 300 / 500 / 1000	16.15
150 / 750 / 1500	24.2

Model P60 Output U/I

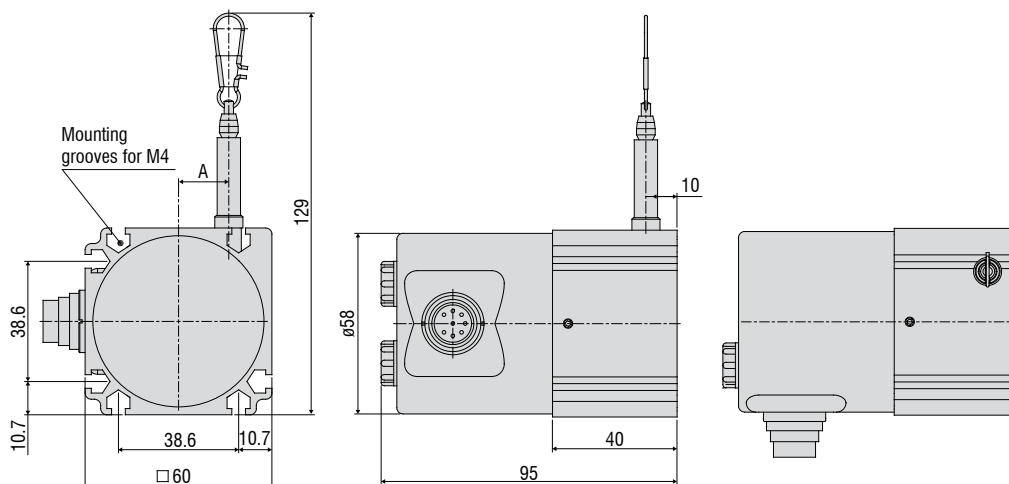

Measuring range (mm)	A (mm)
100 / 300 / 500 / 1000	16.15
150 / 750 / 1500	24.2

Model	WDS-100-P60	WDS-150-P60	WDS-300-P60	WDS-500-P60	WDS-750-P60	WDS-1000-P60	WDS-1500-P60	
Output	P/U/I							
Measuring range	100mm	150mm	300mm	500mm	750mm	1000mm	1500mm	
Linearity	±0.1% FSO	-	-	-	±0.5mm	±0.75mm	±1mm	±1.5mm
	±0.25% FSO	-	-	±0.75mm	-	-	-	-
	±0.5% FSO	±0.5mm	±0.75mm	-	-	-	-	-
Resolution	towards infinity							
Sensor element	conductive plastic/ wire potentiometer		hybrid potentiometer					
Temperature range	-20 °C ... +80 °C							
Material	housing	aluminum						
	draw-wire	coated polyamide stainless steel (ø 0.45mm)						
Sensor mounting	mounting grooves in the housing							
Wire mounting	wire clip							
Wire acceleration	approx. 10 - 15g (depends on measuring range)							
Wire retraction force (min)	6.5N	4.5N	6N	6N	4N	5N	3.5N	
Wire extension force (max)	7.5N	5.5N	7.5N	7.5N	5.5N	7.5N	5.5N	
Protection class	IP65 (only if connected)							
Vibration	20g, 20Hz - 2kHz							
Mechanical shock	50g, 10ms							
Electrical connection	P	integrated cable, radial, 1m						
	U, I	flange connector, radial, 8-pin, DIN45326						
Weight	approx. 370g							

FSO = Full Scale Output
Specifications for analog outputs on page 51.

Article description

WDS -	100 -	P60 -	CR -	P
				Output option: P = potentiometer (with connection CR) U = voltage (with connection SR) I = current (with connection SR)
				Connection: SR: radial plug CR: integrated cable, radial, 1m
				Model P60
				Measuring range in mm



- Robust aluminum profile housing
- Customized versions for OEM
- Incremental/absolute encoder

Model P60

MR (mm)	A (mm)
1000	16.15
1500	24.2

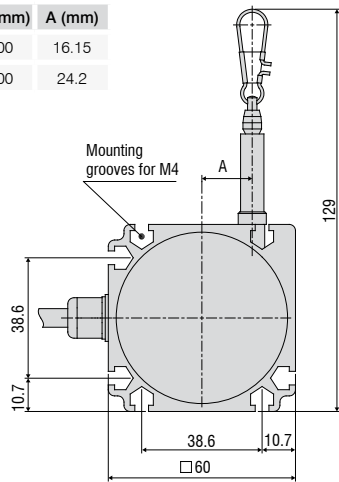

Output HTL/TTL

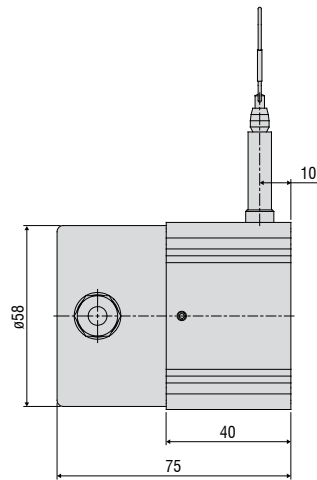

Output SSI

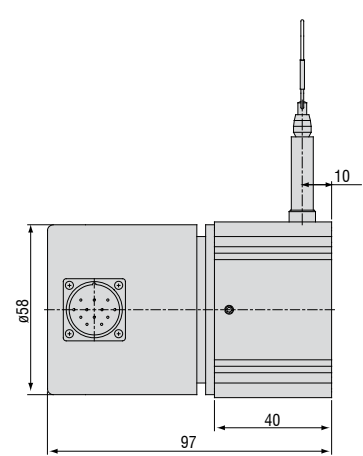

Model P60 Output CO/PB

MR (mm)	A (mm)
1000	16.15
1500	24.2

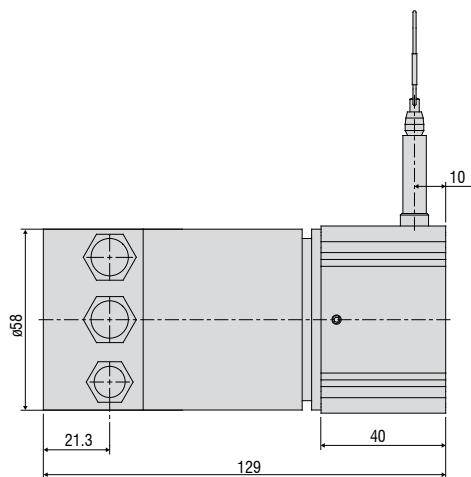
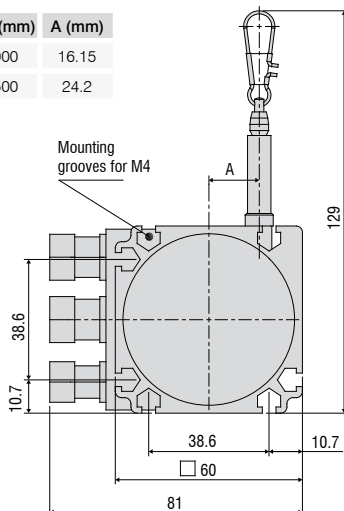

Model		WDS-1000-P60	WDS-1500-P60
Output		HTL, TTL, PB, CO, SSI	
Measuring range		1000mm	1500mm
Linearity	±0.02% FSO	±0.2mm	±0.3mm
Resolution	HTL, TTL	0.067mm (15 pulses/mm)	0.1mm (10 pulses/mm)
Resolution	SSI, PB, CO	0.012mm	0.018mm
Sensor element		incremental encoder	
Temperature range		-20 °C ... +80 °C	
Material	housing	aluminum	
	draw-wire	coated polyamide stainless steel (ø 0.45mm)	
Sensor mounting		mounting grooves in the housing	
Wire mounting		wire clip	
Wire acceleration		10g	15g
Wire retraction force (min)		5N	3.5N
Wire extension force (max)		7.5N	5.5N
Protection class		IP65 (only if connected)	
Vibration		20g, 20Hz - 2kHz	
Mechanical shock		50g, 10ms	
Electrical connection	HTL, TTL	integrated cable, radial, 1m	
	SSI	flange connector, radial, 12-pin	
	PB, CO	bus cover	
Weight		approx. 1kg	

FSO = Full Scale Output

Specifications for digital outputs on page 52.

Article description

WDS -	1000 -	P60 -	CR -	TTL
				Output option: HTL TTL CO: CANopen PB: Profibus DP SSI
				Connection: SR (Output SSI): radial plug CR (Output HTL, TTL): integrated cable, radial, 1m BH (Output CO, PB): bus cover
				Model P60
				Measuring range in mm



- Robust aluminum profile housing
- Customized versions for OEM
- Potentiometer, current and voltage output

Model P96 Output P

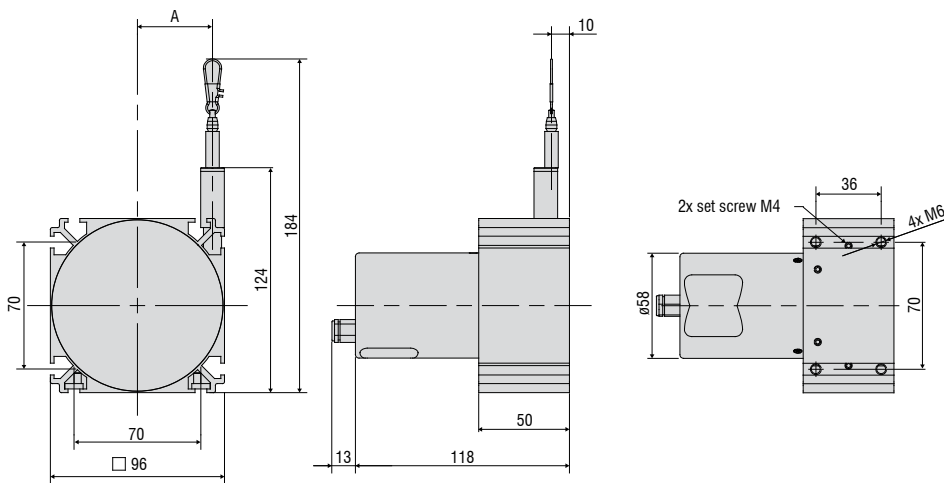

MR (mm)	A (mm)
2000	32
2500	41.4

Model P96 Output U/I

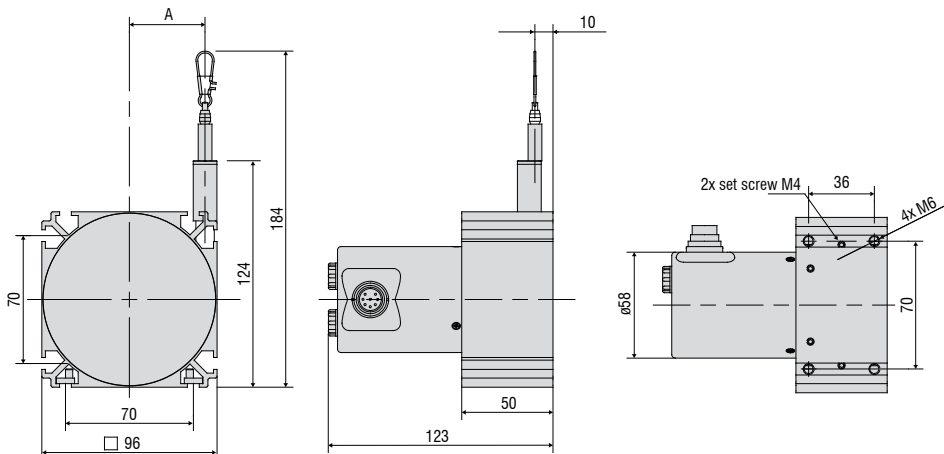

MR (mm)	A (mm)
2000	32
2500	41.4

Model	WDS-2000-P96	WDS-2500-P96
Output	P/U/I	
Measuring range	2000mm	2500mm
Linearity	±0.1% FSO	±2.5mm
Resolution	towards infinity	
Sensor element	hybrid potentiometer	
Temperature range	-20 °C ... +80 °C	
Material	housing	aluminum
	draw-wire	coated polyamide stainless steel (ø 0.8mm)
Sensor mounting	slot nuts	
Wire mounting	wire clip	
Wire acceleration	8g	
Wire retraction force (min)	7.5N	5.5N
Wire extension force (max)	11N	9N
Protection class	IP65 (only if connected)	
Vibration	20g, 20Hz - 2kHz	
Mechanical shock	50g, 10ms	
Electrical connection	P	integrated cable, radial, 1m
	U, I	flange connector, axial, 8-pin DIN45326
Weight	approx. 1.1kg	

FSO = Full Scale Output
 Specifications for analog outputs on page 51.

Article description

WDS -	2000 -	P96 -	CA -	P
				Output option: P = potentiometer (with connection CA) U = voltage (with connection SR) I = current (with connection SR)
				Connection: SR: radial plug CA: integrated cable, axial, 1m
				Model P96
				Measuring range in mm



- Robust aluminum profile housing

- Incremental/absolute encoder

Model P96

Output HTL/TTL

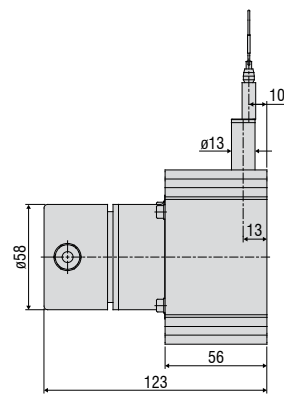
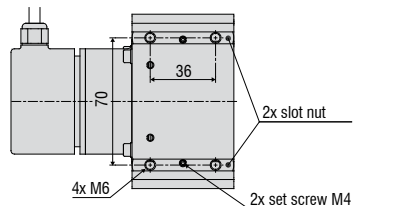
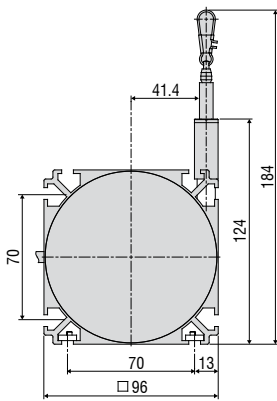

Output CO/PB

Output SSI

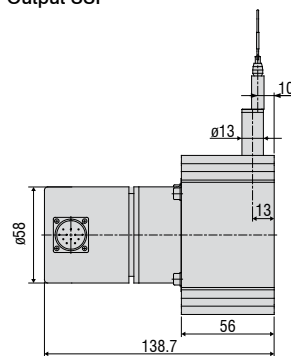
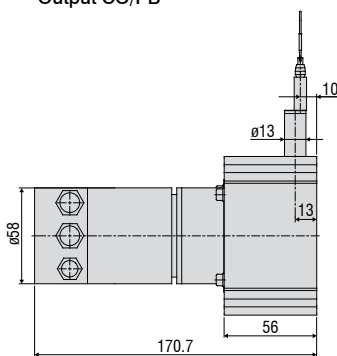

Model	WDS-3000-P96	
Output	HTL, TTL, SSI, PB, CO	
Measuring range	3000mm	
Linearity	±0.02% FSO	±0.6mm
Resolution	HTL, TTL	0.087mm (11.53 pulses/mm)
Resolution	SSI, PB, CO	0.032mm
Sensor element	incremental/absolute encoder	
Temperature range	-20 °C ... +80 °C	
Material	housing	aluminum
	draw-wire	coated polyamide stainless steel (ø 0.8mm)
Sensor mounting	slot nuts	
Wire mounting	wire clip	
Wire acceleration	7g	
Wire retraction force (min)	5.5N	
Wire extension force (max)	9N	
Protection class	IP65 (only if connected)	
Vibration	20g, 20Hz - 2kHz	
Mechanical shock	50g, 10ms	
Electrical connection	HTL, TTL	integrated cable, radial, 1m
	SSI	flange connector, radial, 12-pin
	PB, CO	bus cover
Weight	approx. 1.7kg	

FSO = Full Scale Output

Specifications for digital outputs on page 52.

Article description

WDS -	3000 -	P96 -	CR -	TTL
				Output option: HTL TTL CO: CANopen PB: Profibus DP SSI
				Connection: SR (Output SSI): radial plug CR (Output HTL, TTL): integrated cable, radial, 1m BH (Output CO, PB): bus cover
				Model P96
				Measuring range in mm



- Robust aluminum profile housing
- Customized versions for OEM
- Potentiometer, current and voltage output

Model P115 (Measuring range 3000/4000/5000mm)

Output U/I

Output P

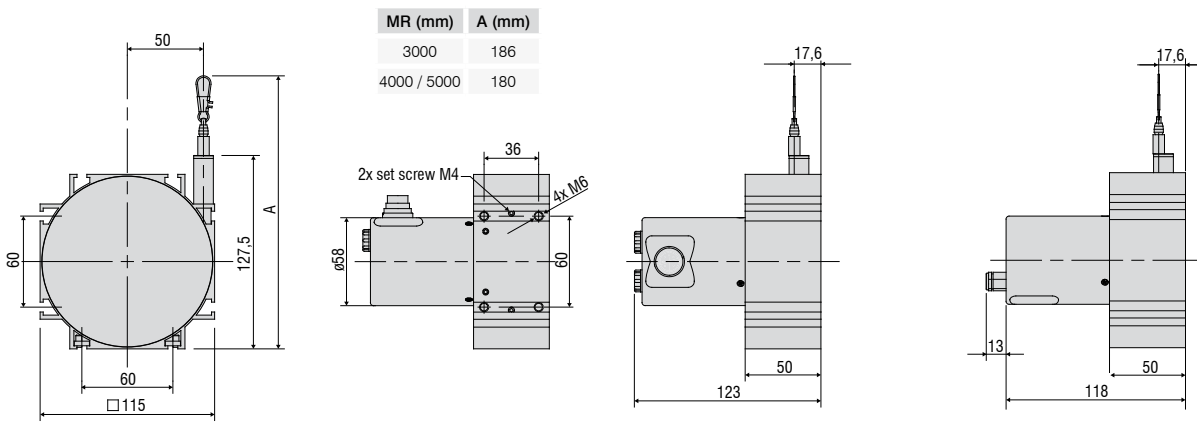

Model P115 (Measuring range 7500/10000/15000mm)

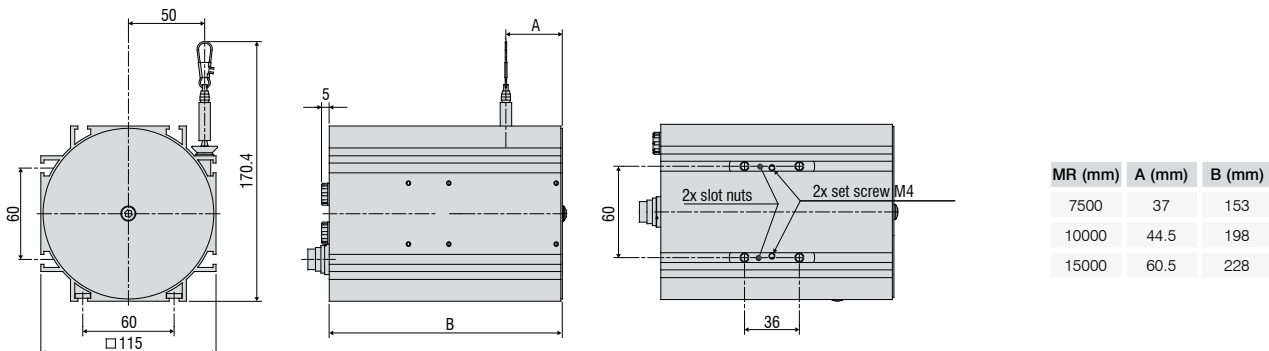

Model		WDS-3000-P115	WDS-4000-P115	WDS-5000-P115	WDS-7500-P115	WDS-10000-P115	WDS-15000-P115
Measuring range		3000mm	4000mm	5000mm	7500mm	10000mm	15000mm
Output		P, U, I					
Linearity	±0.1% FSO	±3mm	-	-	-	-	-
	±0.15% FSO	-	±6mm	±7.5mm	±11.3mm	±15mm	±22.5mm
Resolution		towards infinity					
Sensor element		hybrid potentiometer					
Temperature range		-20 °C ... +80 °C					
Material	housing	aluminum					
	draw-wire	coated polyamide stainless steel (ø 0.45mm)			coated polyamide stainless steel (ø 1.0mm)		
Sensor mounting		slot nut					
Wire mounting		wire clip					
Wire acceleration		approx. 6g					
Wire retraction force (min)		4.5N	4N	4N	8N	8N	8N
Wire extension force (max)		8N	8.5N	9N	24N	21N	25N
Protection class		IP65 (only if connected)					
Vibration		20g, 20Hz - 2kHz					
Mechanical shock		50g, 20ms					
Electrical connection	P	integrated cable, axial, 1m					
	U, I	flange connector, radial, 8-pin, DIN45326					
Weight		approx. 1.1kg			2.2kg	3.2kg	3.5kg

FSO = Full Scale Output

Specifications for analog outputs on page 51.

Article description

WDS -	3000 -	P115 -	CA -	P
				P: potentiometer U: voltage I: current
				connection CA: P115-3000/4000/5000 connection SA: P115-7500/10000/15000 connection SR: P115-3000/4000/5000 connection SA: P115-7500/10000/15000 connection SR: P115-3000/4000/5000 connection SA: P115-7500/10000/15000
				Connection: SR: radial plug SA: axial plug CA: integrated cable, axial, 1m
				Model P115
				Measuring range in mm



- Robust aluminum profile housing
- Customized versions for OEM
- Incremental/absolute encoder

Model P115

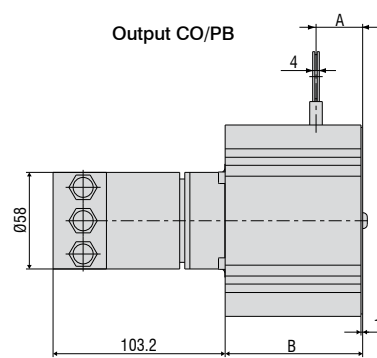
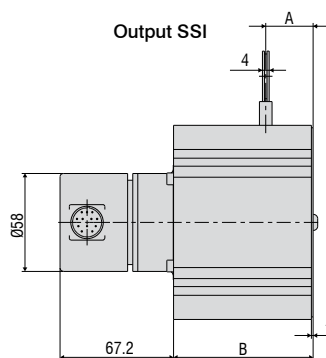
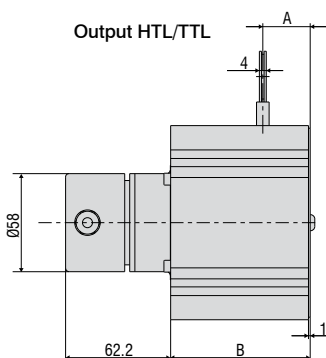
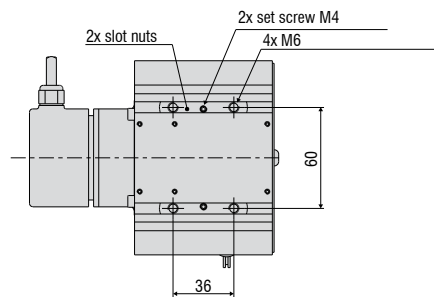
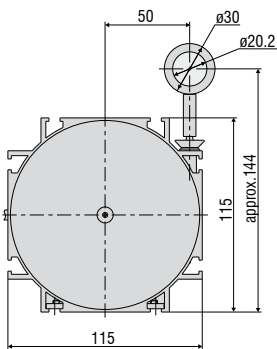

MR (mm)	A (mm)	B (mm)
5000	28	82.5
7500	37	105.5
10000	44.5	148.5
15000	61	180.5

Model	WDS-5000-P115	WDS-7500-P115	WDS-10000-P115	WDS-15000-P115
Measuring range	5000mm	7500mm	10000mm	15000mm
Output	HTL, TTL, SSI, PB, CO			
Linearity	±0.01% FSO	-	-	±1mm
	±0.02% FSO	±1mm	±1.5mm	-
Resolution	HTL, TTL	0.105mm (9.52 pulses/mm)		
	SSI, PB, CO	0.038mm		
Sensor element	incremental/absolute encoder			
Temperature range	-20 °C ... +80 °C			
Material	housing	aluminum		
	draw-wire	coated polyamide stainless steel (ø 1.0mm)		
Sensor mounting	slot nuts			
Wire mounting	eyelet			
Wire acceleration	5g	6g	3g	3g
Wire retraction force (min)	4N	8N	8N	8N
Wire extension force (max)	16N	24N	21N	25N
Protection class	IP65 (only if connected)			
Vibration	20g, 20Hz - 2kHz			
Mechanical shock	50g, 10ms			
Electrical connection	HTL, TTL	integrated cable, radial, 1m		
	SSI	flange connector, radial, 12-pin		
	PB, CO	bus cover		
Weight	approx. 2kg	approx. 2.5kg	approx. 3.5kg	approx. 4.5kg

FSO = Full Scale Output

Specifications for digital outputs on page 52.

Article description

WDS -	5000 -	P115 -	CR -	TTL
				Output option: HTL TTL CO: CANopen PB: Profibus DP SSI
				Connection: SR (Output SSI): radial plug CR (Output HTL, TTL): integrated cable, radial, 1m BH (Output CO, PB): bus cover
				Model P115
				Measuring range in mm



- Robust aluminum profile housing
- Customized versions for OEM
- Incremental / absolute encoder

Model P200

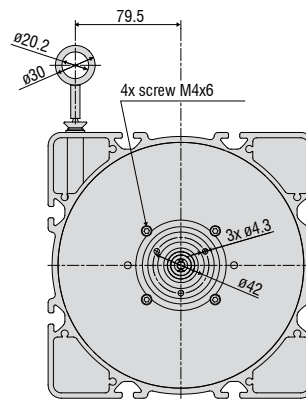
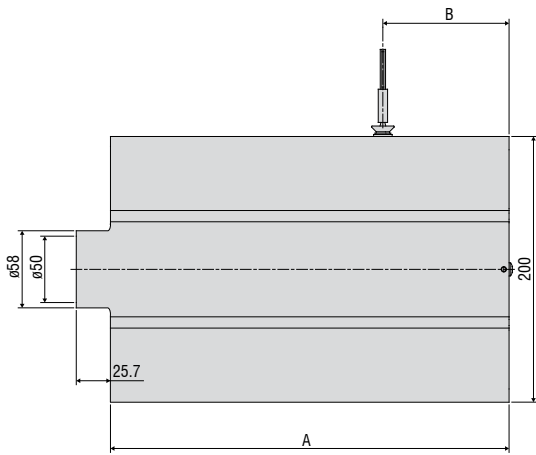

MR (mm)	A (mm)	B (mm)
30000	268	75
40000	300	95
50000	333.5	95

Output P200-HTL/TTL

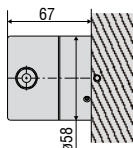

Output P200-SSI

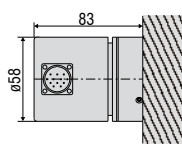

Output P200-CO/PB

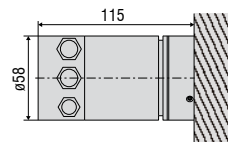

Model	WDS-30000-P200	WDS-40000-P200	WDS-50000-P200	
Measuring range	30000mm	40000mm	50000mm	
Output	HTL, TTL, SSI, PB, CO			
Travel per encoder revolution	500mm			
Linearity	±0.01% FSO	±3mm	±4mm	±5mm
Resolution	HTL, TTL	0.167mm (6 pulses/mm)		
	SSI, PB, CO	0.061mm		
Temperature range	-20 °C ... +80 °C			
Sensor element	incremental/absolute encoder			
Material	housing	aluminum		
	draw-wire	coated polyamide stainless steel (ø 0.8mm)		
Wire mounting	eyelet			
Sensor mounting	slot nuts			
Wire acceleration	2g			
Wire retraction force (min)	12N	11N	11N	
Wire extension force (max)	22N	22N	24N	
Protection class	IP65			
Electrical connection	HTL, TTL	integrated cable, radial, 1m		
	SSI	flange connector, radial, 12-pin		
	PB, CO	bus cover		
Weight	approx. 10kg	approx. 11kg	approx. 12kg	

FSO = des Messbereichs
Specifications for digital outputs on page 52.

Article description

WDS -	30000 -	P200 -	CR -	TTL
				Output options: HTL TTL CO: CANopen PB: Profibus DP SSI
				Connection: SR (Output SSI): radial plug CR (Output HTL, TTL): integrated cable, radial, 1m BH (Output CO, PB): bus cover
				Model P200
				Measuring range in mm



- Use almost any encoder
- Robust aluminum profile housing
- High quality sensor components

Rugged draw-wire mechanics for encoder mounting

The wireSENSOR mechanics of the Z60, P96, P115 and P200 series are designed for easy mounting of an incremental or absolute encoder. The selection of the interface, resolution and type of connection can therefore be individually configured. Optimum matching to the signal conditioning system is ensured. High precision components and a rugged housing offer high operational reliability and a long life time even under harsh industrial conditions.

A complete measurement unit always consists of the basic draw-wire mechanism and the adapter for the customer-specific encoder. The adapter contains all the necessary mounting accessories for fitting the encoder and is included in delivery of the P96, P115 and P200 series.

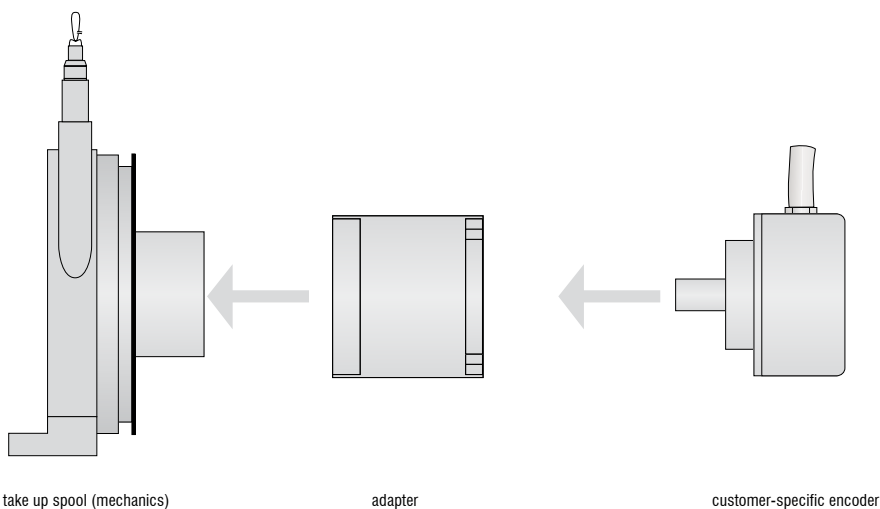

For the customer-specific encoder or potentiometer various draw-wire mechanics are available with measuring ranges up to 50m.

Model		WDS-1500 Z60-M	WDS-3000 P96-M	WDS-5000 P115-M	WDS-7500 P115-M	WDS-10000 P115-M	WDS-15000 P115-M	WDS-30000 P200-M	WDS-40000 P200-M	WDS-50000 P200-M
Measuring range		1500mm	3000mm	5000mm	7500mm	10000mm	15000mm	30000mm	40000mm	50000mm
Output		depends on encoder								
Linearity	±0.01% FSO	-	-	-	-	±1mm	±1.5mm	±3mm	±4mm	±5mm
	±0.02% FSO	±0.3mm	±0.6mm	±1mm	±1.5mm	-	-	-	-	-
Resolution		depends on encoder								
Travel per encoder revolution		150mm	260.09mm	315.07mm				500mm		
Suitable adapter-flange for encoder ø 58mm	clamping flange	WDS-EAC 1	WDS-EAC 96/200	WDS-EAC 115				WDS-EAC 96/200		
	synchro flange	WDS-EAS 1	included in delivery							
Temperature range	operation	-20...+80 °C								
	storage	-40...+80 °C								
Material	housing	aluminum								
	draw-wire	coated polyamide stainless steel								
		ø 0.45mm	ø 0.8mm	ø 1.0mm				ø 0.8mm		
Wire mounting		wire clip	thread M4	eyelet						
Sensor mounting		2 mounting holes	slot nuts							
Wire acceleration		10g	7g	5g	6g	3g	3g			
Wire retraction force (min)		3.5N	5N	4N	8N	8N	8N	12N	11N	11N
Wire extension force (max)		5.5N	10N	16N	24N	21N	25N	22N	22N	24N
Protection class		depends on encoder								
Vibration		20g, 20Hz...2kHz								
Mechanical shock		50g, 10ms								
Weight		0.3kg	1.1kg	1.4kg	1.9kg	2.8kg	3.2kg	9.5kg	10kg	11kg

FSO = Full Scale Output

Article description

WDS -	5000 -	P115 -	M -	SO
				Wire brush (only P115/P200)
				Mechanics
				Model Z60/P96/P115/P200
				Measuring range in mm

Model Z60

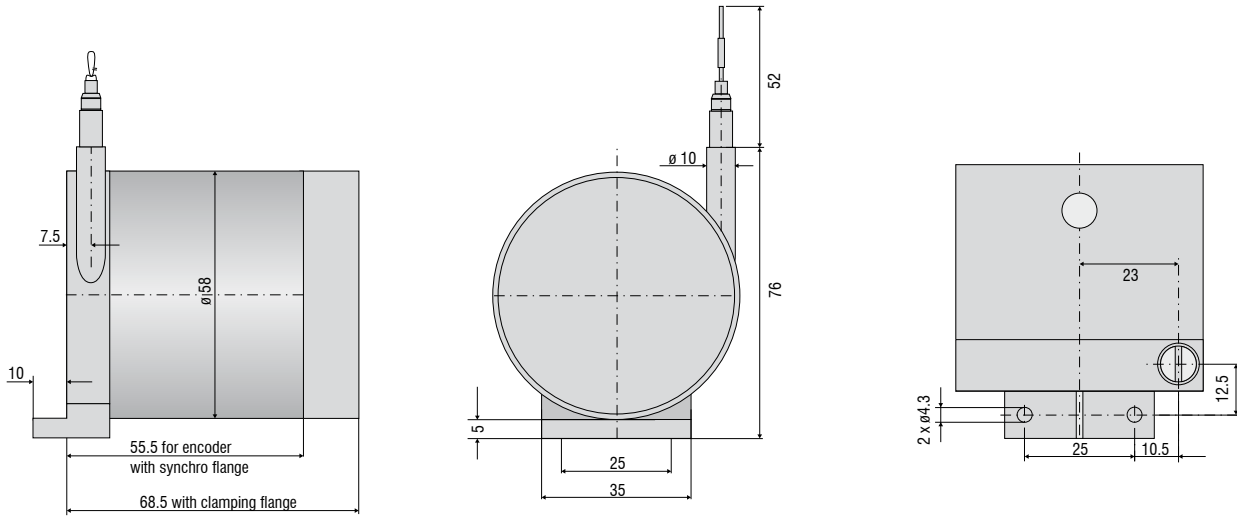

Model P96

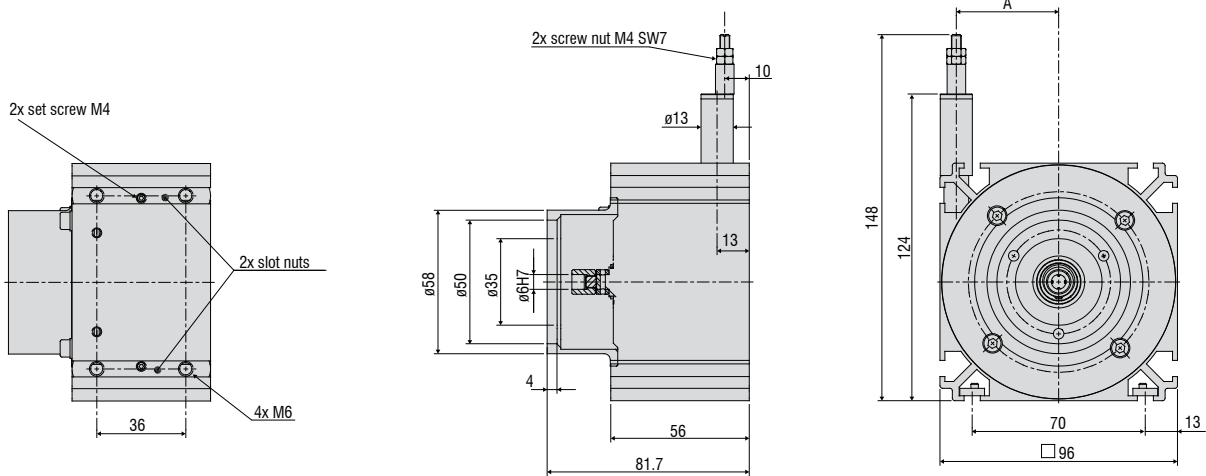

MR (mm)	A (mm)
2000	26
3000	41.5

Model P115

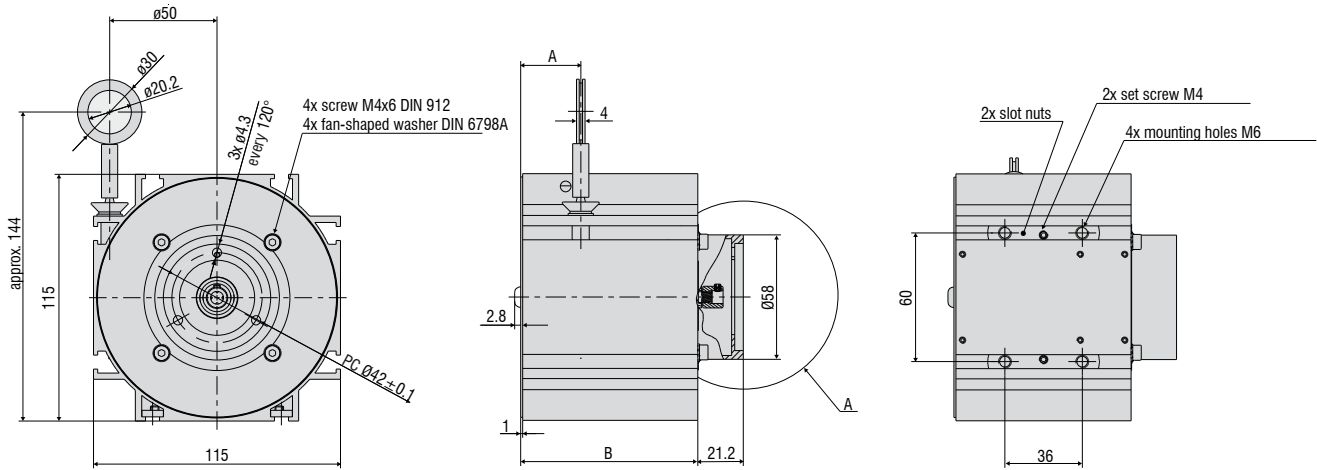

MR (mm)	A (mm)	B (mm)
5000	28	82.5
7500	37	105.5
10000	44.5	148.5
15000	61	180.5

Model P200

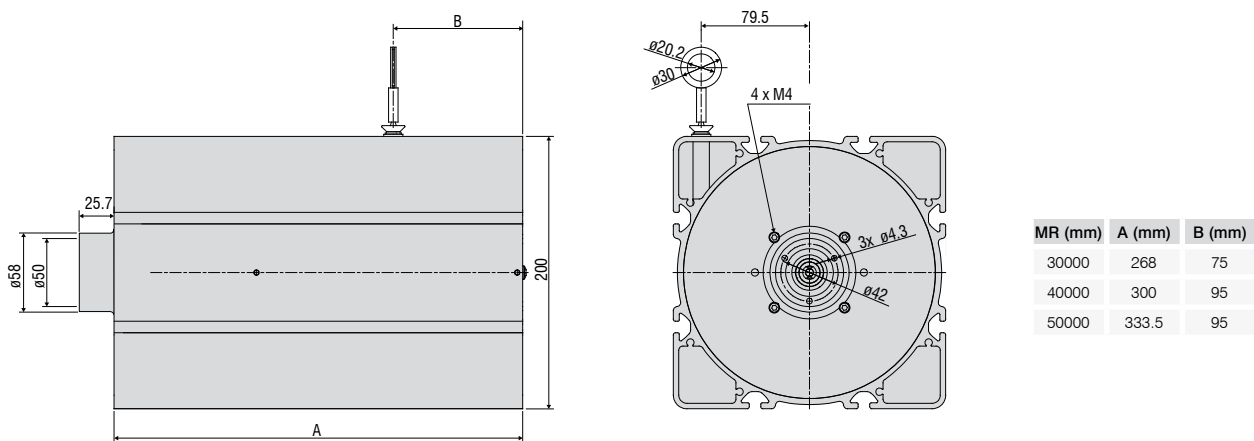

MR (mm)	A (mm)	B (mm)
30000	268	75
40000	300	95
50000	333.5	95

Model	WPS-2300-MK88-M	WPS-5000-MK88-M
Measuring range	2300mm	5000mm
Output	depends on encoder	
Linearity	±0.1% FSO (±2.3mm)	±0.4% FSO (±20mm)
Resolution	depends on encoder	
Travel per encoder revolution	238.8mm ±0.3mm	240.0mm ±1mm
Repeatability	±1mm	±8mm
Temperature range	operation	-40 °C...+85 °C
	storage	-40 °C...+85 °C
Material	housing	PA 6 GF 30
	draw-wire	coated polyamide stainless steel (ø 0.45mm)
Wire mounting	wire clip	
Sensor mounting	mounting holes	
Wire acceleration (max)	5g	
Wire retraction force (min)	3N	
Wire extension force (max)	9N	
Vibration	20g, 20Hz...2kHz	
Mechanical shock	50g, 10ms	
Suitable encoder	synchro flange ø58mm; shaft ø6mm	

FSO = Full Scale Output

Article description

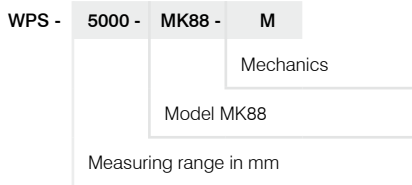

Sensitivity characteristics MK88

The WPS-2300-MK88-M is designed with only one wire layer which is wound onto the drum. This sensor design achieves the highest measurement accuracy.

If a reduced measurement accuracy is sufficient, larger measuring ranges can be achieved with the same sensor dimensions. This can be seen by means of a sensitivity characteristics (see diagram).

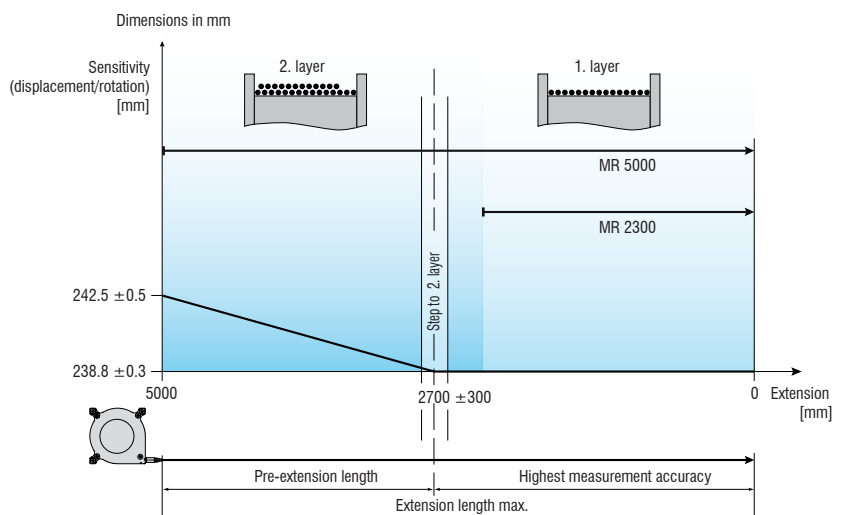

Accessories:

WE-xxx-M4	Wire extension with M4-wire connection, x=length
WE-xxx-Clip	Wire extension with eyelet, x=length
TR1-WDS	Pulley wheel, adjustable
TR3-WDS	Pulley wheel, fixed
GK1-WDS	Attachment head for M4
MH1-WDS	Magnetic holder for wire mounting
MH2-WDS	Magnetic holder for sensor mounting
MT-60-WDS	Mounting clamp for WDS-P60
FC8	Female connector for WDS, 8-pin
FC8/90	Female connector 90° for WDS
PC 3/8-WDS	Sensor cable, length 3m
PS 2020	(Power Supply 24 V / 2,5 A, Input 100 - 240 VAC, output 24 VDC / 2.5 A, for snap in mounting on DIN 50022 rail)
WDS-MP60	Mounting plate for P60 sensors

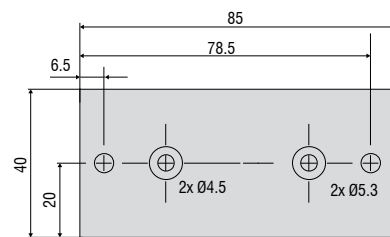
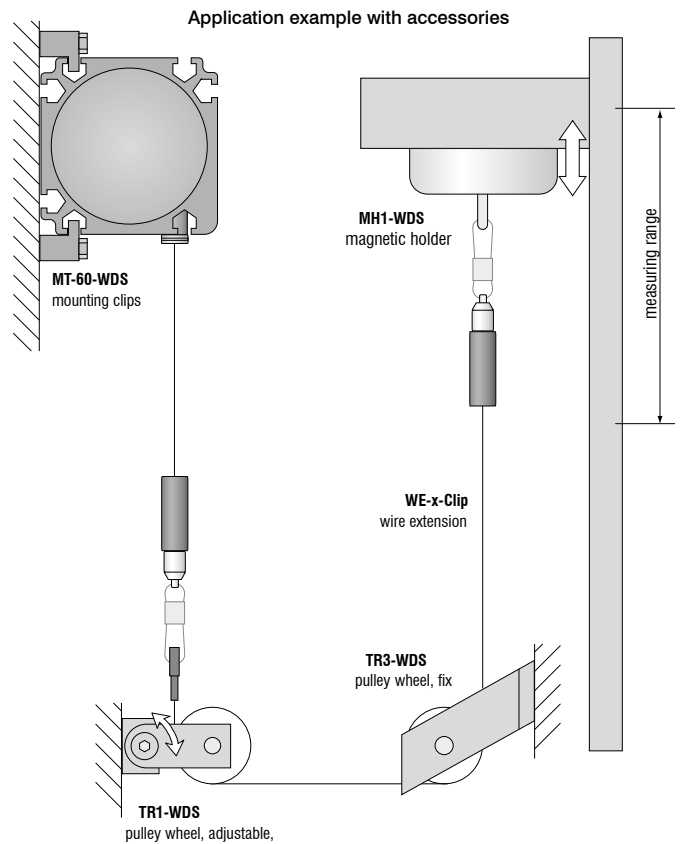

Mounting plate WDS-MP60

Installation information:



Wire attachment: The free return of the measurement wire is not permissible and it is essential that this is avoided during installation.

Wire exit angle:

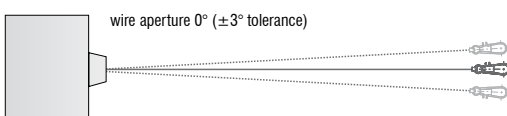
When mounting a draw-wire displacement sensor, a straight wire exit ($\pm 3^\circ$ tolerance) must be taken into account. If this tolerance is exceeded, increased material wear on the wire and at the wire aperture must be expected.

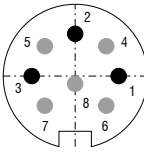
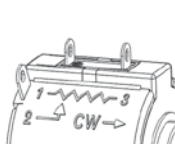

Output	Plug M16 -SA / -SR	Integrated cable -CA / -CR	Open contacts
--------	-----------------------	-------------------------------	---------------

Potentiometric output (P)				
Supply voltage	max. 32VDC at 1kOhm / 1 Wmax	 <p>sensor side</p> <p>1 = input + 2 = grounding 3 = signal</p>		 <p>1 = input + 2 = signal 3 = grounding</p>
Resistance	1kOhm $\pm 10\%$ (potentiometer)			
Temperature coefficient	$\pm 0.0025\%$ FSO/ $^{\circ}$ C			

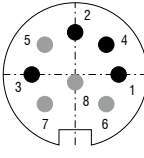
Voltage output (U)				
Supply voltage	14 ... 27VDC (non stabilized)	 <p>sensor side</p> <p>1 = supply 2 = grounding 3 = signal 4 = ground</p>	<p>white = supply brown = grounding green = signal yellow = ground</p>	
Current consumption	max. 30mA			
Output voltage	0 ... 10VDC Option 0 ... 5 / ± 5 V			
Load impedance	$> 5k\Omega$			
Signal noise	$0.5mV_{eff}$			
Temperature coefficient	$\pm 0.005\%$ FSO/ $^{\circ}$ C			
Electromagnetic compatibility (EMC)	EN 61000-6-4 EN 61000-6-2			
Adjustment ranges (if supported by the model)				
Zero	$\pm 20\%$ FSO			
Sensitivity	$\pm 20\%$			

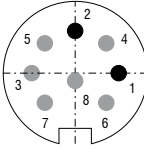
Current Output (I)				
Supply voltage	14 ... 27VDC (non stabilized)	 <p>sensor side</p> <p>1 = supply 2 = grounding</p>	<p>white = supply brown = grounding</p>	
Current consumption	max. 35mA			
Output current	4 ... 20mA			
Load	$< 600\Omega$			
Signal noise	$< 1,6 \mu A_{eff}$			
Temperature coefficient	$\pm 0.01\%$ FSO/ $^{\circ}$ C			
Electromagnetic compatibility (EMC)	EN 61000-6-4 EN 61000-6-2			
Adjustment range (if supported by the model)				
Zero	$\pm 18\%$ FSO			
Sensitivity	$\pm 15\%$			

Contact description

1 UB	Encoder power supply connection
2 GND	Encoder ground connection. The voltage drawn to GND is UB.
3 Pulses +	Positive SSI pulse input. Pulse + forms a current loop with pulse -. A current of approx. 7 mA in direction of pulse + input generates a logical 1 in positive logic.
4 Data +	Positive, serial data output of the differential line driver. A High level at the output corresponds to logical 1 in positive logic.
5 ZERO	Zero setting input for setting a zero point at any desired point within the entire resolution. The zeroing process is triggered by a High pulse (pulse duration ≥ 100 ms) and must take place after the rotating direction selection (UP/DOWN). For maximum interference immunity, the input must be connected to GND after zeroing.
6 Data -	Negative, serial data output of the differential line driver. A High level at the output corresponds to logical 0 in positive logic.
7 Pulses -	Negative SSI pulse input. Pulse - forms a current loop with pulse +. A current of approx. 7 mA in direction of pulse - input generates a logical 0 in positive logic.
8 / 10 <u>DATAVALID</u> <u>DATAVALID MT</u>	Diagnosis outputs DV and DV MT Jumps in data word, e.g. due to defective LED or photoreceiver, are displayed via the DV output. In addition, the power supply of the multiturn sensor unit is monitored and the DV MT output is set when a specified voltage level is dropped below. Both outputs are Low-active, i.e. are switched through to GND in the case of an error.
9 UP/DOWN	UP/DOWN counting direction input. When not connected, this input is on High. UP/ DOWN-High means increasing output data with a clockwise shaft rotating direction when looking at the flange. UP/ DOWN-Low means increasing values with a counter-clockwise shaft rotating direction when looking at the flange.
11 / 12	Not in use

Pin assignment

Pin	Cable color	Assignment
1	brown	UB
2	black	GND
3	blue	Pulses +
4	beige	Data +
5	green	ZERO
6	yellow	Data -
7	violet	Pulses -
8	brown/yellow	<u>DATAVALID</u>
9	pink	UP/ DOWN
10	black/yellow	<u>DATAVALID</u> <u>MT</u>
11	-	-
12	-	-

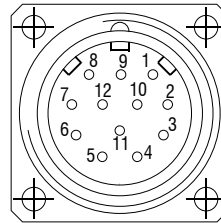

Please use leads twisted in pairs for extension cables.

Inputs

Control signals UP/DOWN and Zero

Level High > 0.7 UB

Level Low < 0.3 UB

Connection: UP/DOWN input with 10kohms to UB, zeroing input with 10kohms to GND.

SSI pulse

Optocoupler inputs for electrical isolation

Outputs

SSI data RS485 driver

Diagnostic outputs

Push-pull outputs are short-circuit-proof

Level High > UB -3.5V (with I = -20mA)

Level Low $\leq 0.5V$ (with I = 20mA)

CANopen features	
Bus protocol	CANopen
Device profile	CANopen - CiA DSP 406, V 3.0
CANopen Features	Device Class 2, CAN 2.0B
Operating modes (with SDO progr.)	Polling Mode (asynch, via SDO) Cyclic Mode (asynch-cyclic) The encoder cyclically sends the current process actual value without a request by a master. The cycle time can be parameterized for values between 1 and 65535 ms. Synch Mode (synch-cyclic) The encoder sends the current actual process value after receiving a synch telegram sent by a master. The synch counter in the encoder can be parameterized so that the position value is not sent until after a defined number of synch telegrams. Acyclic Mode (synch-acyclic)
Preset value	With the "Preset" parameter the encoder can be set to a desired actual process value that corresponds to the defined axis position of the system. The offset value between the encoder zero point and the mechanical zero point of the system is saved in the encoder.
Rotating direction	With the operating parameter the rotating direction in which the output code is to increase or decrease can be parameterized. Scaling The steps per revolution and the total revolution can be parameterized.
Scaling	The steps per revolution and the total revolution can be parameterized.
Diagnose	The encoder supports the following error messages: - Position and parameter error - Lithium cell voltage at lower limit (Multiturn)
Default setting	50kbit/s, node number 1

Baud rate	Setting Dip Switch		
	1	2	3
10kBit/s	OFF	OFF	OFF
20kBit/s	OFF	OFF	ON
50kBit/s	OFF	ON	OFF
125kBit/s	OFF	ON	ON
250kBit/s	ON	OFF	OFF
500kBit/s	ON	OFF	ON
800kBit/s	ON	ON	OFF
1MBit/s	ON	ON	ON

Contact description CANopen	
CAN_L	CAN Bus Signal (dominant Low)
CAN_H	CAN Bus Signal (dominant High)
UB	Supply voltage 10...30VDC
GND	Ground contact for UB
(Terminals with the same designation are internally interconnected)	

Settings of user address for CANopen
 Address can be set with rotary switch. Example: User address 23

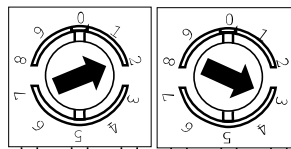
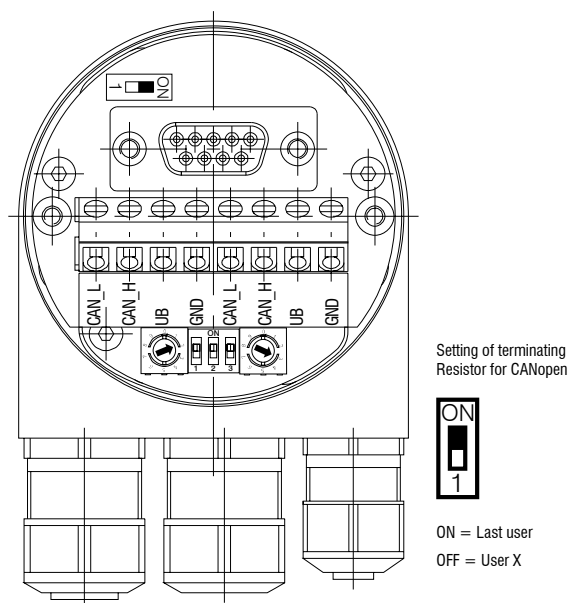

Profibus-DP features

Bus protocol	Profibus-DP
Profibus features	Device Class 1 and 2
Data exch. functions	Input: Position value Additional parameterized speed signal (readout of the current rotary speed) Output: Preset value
Preset value	With the "Preset" parameter the encoder can be set to a desired actual value that corresponds to the defined axis position of the system.
Parameter functions	Rotating direction: With the operating parameter the rotating direction for which the output code is to increase or decrease can be parameterized.
Diagnose	The encoder supports the following error messages: - Position error - Lithium cell voltage at lower limit (Multiturn)
Default setting	User address 00

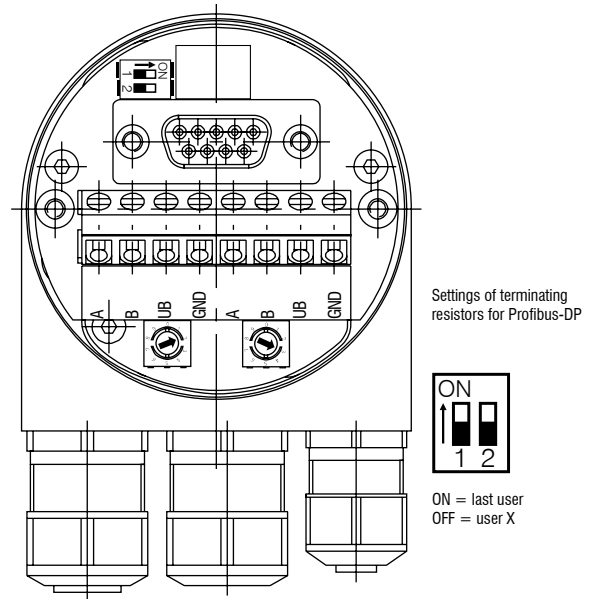
**Settings of user address for Profibus-DP**

Settings of user address for Profibus-DP

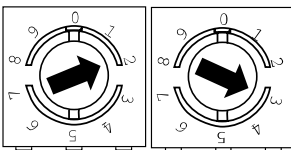
**Contact description Profibus-DP**

A Negative serial data line

B Positive serial data line

UB Supply voltage 10...30VDC

GND Ground contact for UB

(Terminals with the same designation are internally interconnected)

Signal output

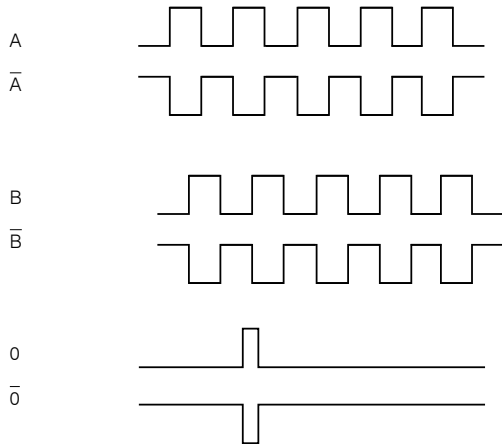

Output TTL	Linedriver (5 VDC)	
Level High	$\geq 2.5V$	(with I = -20mA)
Pegel Low	$\leq 0.5V$	(with I = 20mA)
Load High	$\leq 20mA$	
Output	A, \bar{A} , B, \bar{B} , 0	

Output TTL01/TTL02	NPN (5 VDC $\pm 5\%$)	
Level High	$> 4.5V$	
Level Low	$< 1.0V$	
Load High	$\leq 3mA$	
Output (TTL01)	A, B, 0	
Output (TTL02)	A, \bar{A} , B, \bar{B} , 0	

Output HTL	Push-pull (10 ... 30 VDC)	
Level High	$\geq UB - 3V$	(with I = -20mA)
Level Low	$\leq 1.5V$	(with I = 20mA)
Load High	$\leq 40mA$	
Output	A, \bar{A} , B, \bar{B} , 0	

Output E	Push-pull ((5 VDC)	
Level High	$\geq UB - 2.5V$	
Level Low	$\leq 0.5V$	
Load High	$\leq 50mA$	
Output	A, B, 0	

Output E830	Push-pull ((8 ... 30 VDC)	
Level High	$\geq UB - 3V$	
Level Low	$\leq 2.5V$	
Load High	$\leq 50mA$	
Output	A, B, 0	

Pin assignment TTL, HTL

Pin	Cable color	Assignment
Pin 1	pink	B inv.
Pin 2	blue	UB Sense
Pin 3	red	N (zero impulse)
Pin 4	black	N inv. (zero impulse inv.)
Pin 5	brown	A
Pin 6	green	A inv.
Pin 7	-	-
Pin 8	gray	B
Pin 9	-	-
Pin 10	white/green	GND
Pin 11	white	GND Sense
Pin 12	brown/green	UB

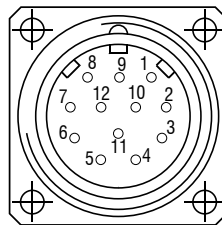

Pin 2 and Pin 12 are internally connected as well as Pin 11 and 10. For cable length >10m twisted pair wires are required.

Connection assignment E, E830

Cable color	Assignment
white	0V
brown	+UB
green	A
-	\bar{A}
yellow	B
-	\bar{B}
gray	0

Connection assignment TTL01

Cable color	Assignment
brown	0V
gray	+UB
white	A
green	B
yellow	0

Connection assignment TTL02

Cable color	Assignment
red	+UB
black	0V
brown	A
black	\bar{A}
orange	B
black	\bar{B}
yellow	0
black	n.c.

High performance sensors made by Micro-Epsilon



Sensors and systems for displacement and position



Sensors and measurement devices for non-contact temperature measurement



2D/3D profile sensors (laser scanner)



Optical micrometers, fiber optic sensors and fiber optics



Color recognition sensors, LED analysers and color inline spectrometer



Measurement and inspection systems