

# Incremental encoders

With through hollow shaft

1...65536 pulses per revolution programmable (interpolated system)

## EIL580P-T - OptoPulse®



EIL580P-T with through hollow shaft

### Features

- Size  $\varnothing 58$  mm
- Precise optical sensing (interpolated)
- Output signal level programmable (TTL or HTL)
- Through hollow shaft,  $\varnothing 8...15$  mm
- Connection radial or tangential
- Pulses per revolution 1...65536, programmable
- High protection up to IP 67
- High resistance to shock and vibrations

### Technical data - electrical ratings

Voltage supply	4.75...30 VDC
Reverse polarity protection	Yes
Short-circuit proof	Yes
Consumption w/o load	$\leq 70$ mA
Initializing time	$\leq 30$ ms after power on
Pulses per revolution	1...65536
Duty cycle	45...55 % typical at 1024, 2048 ppr (further see table Duty cycle)
Reference signal	Zero pulse $90^\circ$ or $180^\circ$
Sensing method	Optical
Output frequency	$\leq 300$ kHz (TTL) $\leq 160$ kHz (HTL)
Output signals	A+, B+, R+, A-, B-, R-
Output stages	TTL/RS422 HTL/push-pull
Programmable parameters	Output level TTL/HTL Pulse number 1...65536 Zero pulse width $90^\circ/180^\circ$ Zero pulse position Signal sequence
Interference immunity	DIN EN 61000-6-2
Emitted interference	DIN EN 61000-6-3
Approval	UL 508 / CSA 22.2

### Technical data - mechanical design

Size (flange)	$\varnothing 58$ mm
Shaft type	$\varnothing 8...15$ mm (through hollow shaft)
Protection DIN EN 60529	IP 65 (without shaft seal), IP 67 (with shaft seal)
Operating speed	$\leq 3000$ rpm ( $+20^\circ\text{C}$ , IP 67) $\leq 6000$ rpm ( $+20^\circ\text{C}$ , IP 65)
Starting torque	$\leq 0.025$ Nm ( $+20^\circ\text{C}$ , IP 65) $\leq 0.03$ Nm ( $+20^\circ\text{C}$ , IP 67)
Materials	Housing: aluminium die-cast Flange: aluminium
Operating temperature	$-40...+100^\circ\text{C}$
Relative humidity	90 % non-condensing
Resistance	DIN EN 60068-2-6 Vibration 30 g, 10-2000 Hz DIN EN 60068-2-27 Shock 250 g, 6 ms
Connection	Flange connector M12, 8-pin Flange connector M23, 12-pin Cable
Weight approx.	300 g

# Incremental encoders

## With through hollow shaft

### 1...65536 pulses per revolution programmable (interpolated system)

**EIL580P-T - OptoPulse®**

#### Part number

**EIL580P- T . . . F . 01024 . B**

Operating temperature

B -40...+100 °C

Pulses programmable

01024 1...65536 programmable (factory setting: 1024)

Voltage supply / output stages

F 4.75...30 VDC, TTL/RS422, 6 channel (Vout = 5 VDC) - Factory setting  
HTL/push-pull 6 channel (Vout = Vin) - programmable by customer

Connection

- R Cable radial, 1 m
- L Cable radial, 2 m
- F Flange connector M23, 12-pin, radial, male contacts, CCW
- B Flange connector M12, 8-pin, radial, male, CCW
- P Cable tangential, 1 m
- Q Cable tangential, 2 m

Protection

- 5 IP 65
- 7 IP 67

Specification hollow shaft

- |   |   |
|---|---|
| 08 ø8 mm, clamping ring at A side           | 15 ø15 mm, clamping ring at A side          |
| U3 ø3/8" (9,52 mm), clamping ring at A side | V3 ø3/8" (9,52 mm), clamping ring at B side |
| 10 ø10 mm, clamping ring at A side          | B0 ø10 mm, clamping ring at B side          |
| 12 ø12 mm, clamping ring at A side          | B2 ø12 mm, clamping ring at B side          |
| U4 ø1/2" (12.7 mm), clamping ring at A side | V4 ø1/2" (12.7 mm), clamping ring at B side |
| 14 ø14 mm, clamping ring at A side          | B4 ø14 mm, clamping ring at B side          |

Flange

- N Without stator coupling
- M With stator coupling 1-armed, hole circle ø63...94 mm, M4, mounting position 180°
- T With stator coupling ø63 mm
- P Torque pin 3 mm, axial/radial

Shaft type

- T Through hollow shaft

(Factory setting: 1024 ppr, Vout = 5 VDC TTL, signal sequence A leading B (CW), zero pulse 90° A&B high)

# Incremental encoders

## With through hollow shaft

1...65536 pulses per revolution programmable (interpolated system)

### EIL580P-T - OptoPulse®

#### Accessories

##### Connectors and cables

10127844	Connection cable 2 m shielded with female connector M12, 8-pin, straight (ESG 34FH0200G)
10129332	Connection cable 5 m shielded with female connector M12, 8-pin, straight (ESG 34FH0500G)
10129333	Connection cable 10 m shielded with female connector M12, 8-pin, straight (ESG 34FH1000G)
11053961	Connection cable 2 m shielded with female connector M12, 8-pin, angled (ESW 33FH0200G)
11053962	Connection cable 5 m shielded with female connector M12, 8-pin, angled (ESW 33FH0500G)
10170054	Connection cable 10 m shielded with female connector M12, 8-pin, angled (ESW 33FH1000G)
11212849	Connection cable 1 m shielded with female connector M23, 12-pin - EIL580P
11212870	Connection cable 2 m shielded with female connector M23, 12-pin - EIL580P
11212871	Connection cable 5 m shielded with female connector M23, 12-pin - EIL580P
11212872	Connection cable 10 m shielded with female connector M23, 12-pin - EIL580P
11119280	Connection cable connector M12 / connector D-SUB, 0.2 m
11119720	Connection cable connector M12 / connector D-SUB, 1 m
11119257	Connection cable connector M23 / connector D-SUB, 0.2 m (S2BG12/K4SG9)
11119723	Connection cable connector M23 / connector D-SUB, 1 m (S2BG12/K4SG9)

##### Mounting accessories

11066081	Torque arm, 1-arm, bolt circle ø82 mm, mounting M4 (mounting kit 003)
11066083	Torque arm, 1-arm, bolt circle ø74...94 mm, mounting M4/M5 (mounting kit 006)
11073119	Torque arm, 1-arm, bolt circle ø65.5...281 mm, mounting M4, can be cut to length (mounting kit 021)
11067367	Torque arm, 1-arm, bolt circle ø74...94 mm, mounting M6 (mounting kit 028)
11113210	Torque arm, 1-arm, bolt circle ø63...94 mm, mounting M4 (mounting kit 047)
11155325	Mounting plate, 1-arm, pitch circle diameter ø95 mm, mounting M6, isolated, rigid, suitable for Baumer torque arm size M6 (DMS 6) (mounting kit 099)

##### Mounting accessories

11129153	Torque arm, 1-arm open, bolt circle ø82...108 mm, mounting M4 (mounting kit 200)
11100198	Stator coupling, 2-armed, bolt circle ø63 mm, mounting M3 (mounting kit 046)
11106627	Fan cover clip 8 mm
11094674	Clamping ring 12/31/ 8 M3 8.8 for EIL580 hollow shaft ø8...10 mm for clamping at A or B side
11094675	Clamping ring 17/31/ 8 M3 8.8 for EIL580 hollow shaft ø12...15 mm for clamping at A side
11116921	Insulating sleeve ø10 mm/ø12 mm/25 mm long
11116923	Insulating sleeve ø12 mm/ø14 mm/25 mm long

##### Programming accessories

11120657	Handheld Programming Tool Z-PA-EI-H
11120547	PC Programming Tool Z-PA-EI-P

# Incremental encoders

With through hollow shaft

1...65536 pulses per revolution programmable (interpolated system)

EIL580P-T - OptoPulse®

## Output signals

Zero pulse electrical 90° A&B high  
(Factory setting at clockwise rotation (CW)  
in view of the encoder flange)

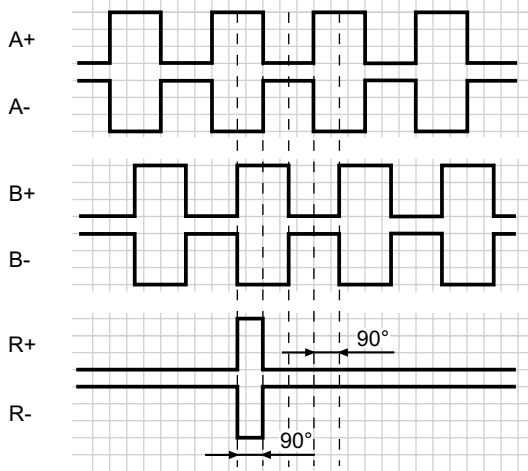

Zero pulse electrical 180° B low  
(at clockwise rotation (CW)  
in view of the encoder flange)

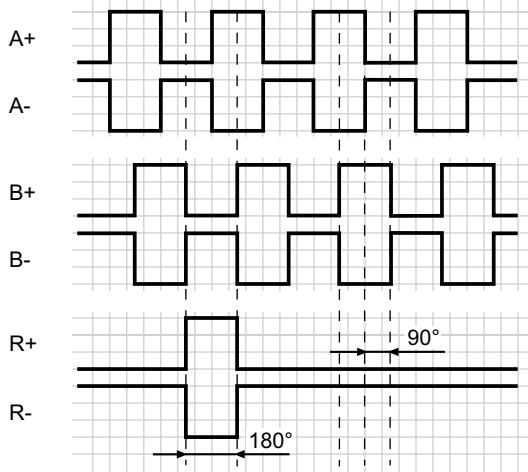

## Trigger level

Outputs	TTL/RS422
Output level High	≥2.5 V
Output level Low	≤0.5 V
Load	≤20 mA

Outputs	HTL/Push-pull
Output level High	≥UB -3 V
Output level Low	≤1.5 V
Load	≤20 mA

## Terminal assignment

### Flange connector M23, 12-pin / cable

Pin	Core color	Assignment
1	pink	B-
2	–	–
3	blue	R+
4	red	R-
5	green	A+
6	yellow	A-
7	–	R-Set <sup>1)</sup>
8	grey	B+
9	–	–
10	white	GND
11	–	–
12	brown	UB

Screen: Connected to housing

Cable data: PUR, [4x2x0,14 mm<sup>2</sup>], bending radius >45,8 mm, outer diameter 6.1 mm

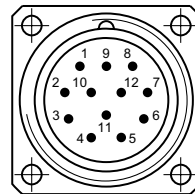

<sup>1)</sup> The R-Set input is used to set the reference pulse (zero pulse) on the current shaft position.  
R-Set = UB ≥ 200 ms

### Flange connector M12, 8-pin

Pin	Assignment
1	GND
2	UB
3	A+
4	A-
5	B+
6	B-
7	R+
8	R-

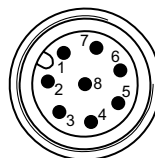

# Incremental encoders

## With through hollow shaft

1...65536 pulses per revolution programmable (interpolated system)

### EIL580P-T - OptoPulse®

#### Duty cycle

The duty cycle (D) is defined as the time ratio between the HIGH pulse duration (H) and the pulse period (T).

System-induced and depending on the pulse number, the measured values may vary which has an impact on speed and position acquisition.

Binary pulse numbers are recommended for speed feedback.

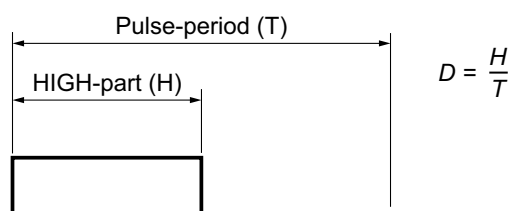

Programmed pulse number	Scan ratio (D) (maximum)	Jitter (+/-) (maximum)
1...1023	45...55 %	5%
1024, 2048	45...55 %	5%
1025...5000	40...60 %	10%
8192, 16384	35...85 %	15%
5001...10000	22...78 %	28%
32768	25...75 %	25%
65536	15...85 %	35%
all other	Jitter[%]=(programmed pulse number -10000)*0,0007%+28%	

# Incremental encoders

With through hollow shaft

1...65536 pulses per revolution programmable (interpolated system)

EIL580P-T - *OptoPulse*®

## Dimensions

**Clamping ring at A-side:**  
Through hollow shaft, flange connector M12 radial

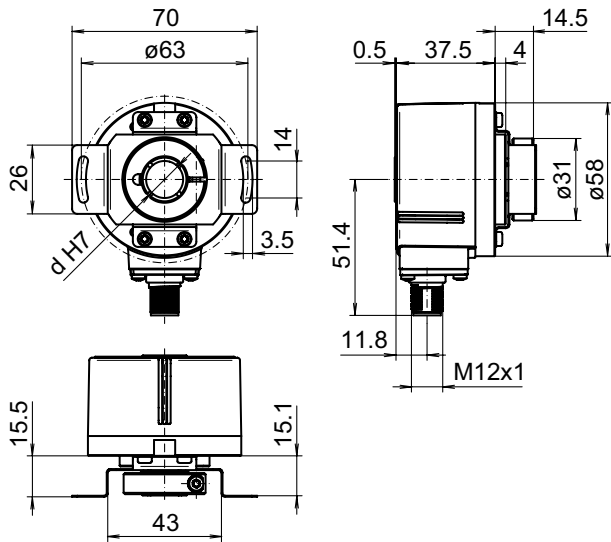

**Clamping ring at A-side:**  
Through hollow shaft, flange connector M23 radial

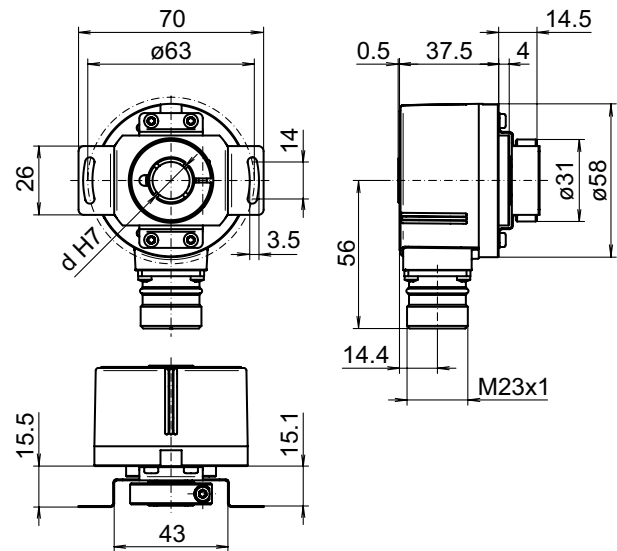

**Clamping ring at A-side:**  
Through hollow shaft, cable radial

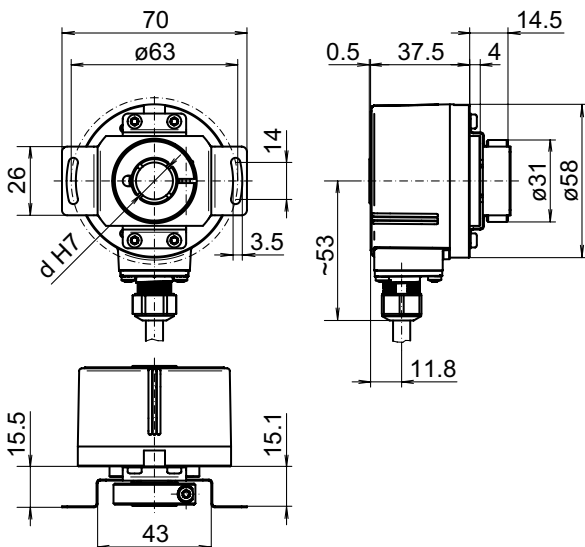

**Clamping ring at A-side:**  
Through hollow shaft, cable tangential

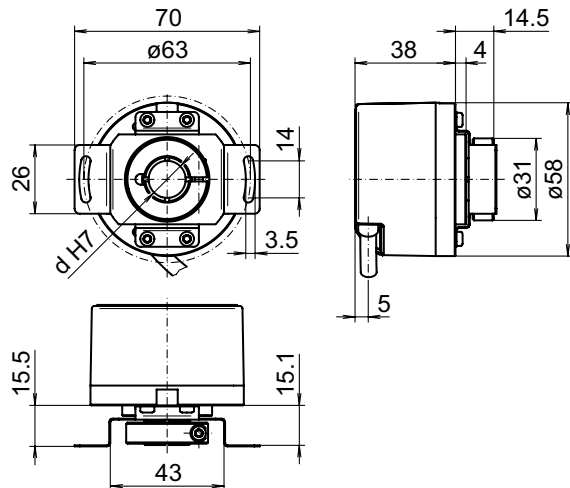

# Incremental encoders

With through hollow shaft

1...65536 pulses per revolution programmable (interpolated system)

EIL580P-T - OptoPulse®

## Dimensions

Clamping ring at B-side:  
Through hollow shaft, flange connector M12 radial

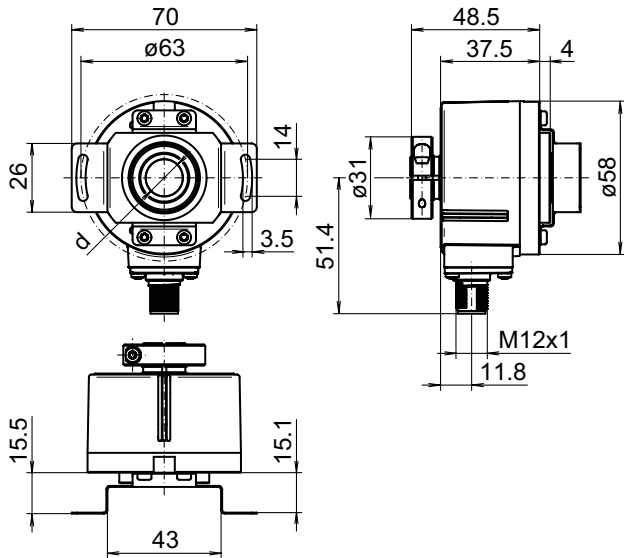

d H7:  $\varnothing 10$ ,  $\varnothing 12$ ,  $\varnothing 14$   
d G7:  $\varnothing 3/8$ " ( $\varnothing 9.52$ ),  $\varnothing 1/2$ " ( $\varnothing 12.7$ )

Clamping ring at B-side:  
Through hollow shaft, flange connector M23 radial

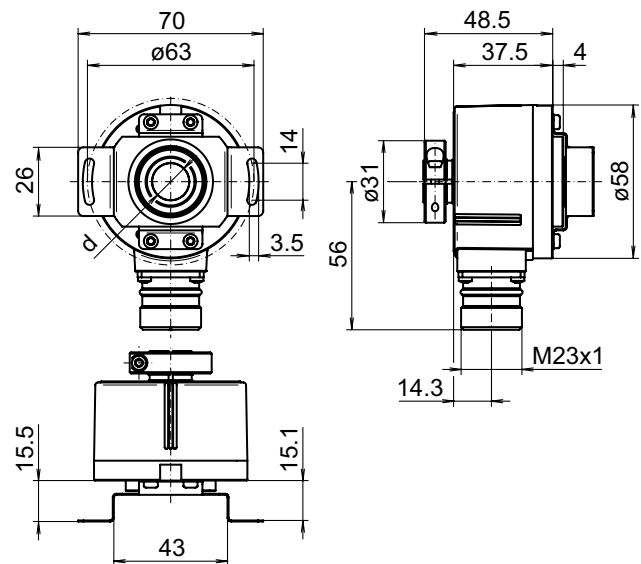

d H7:  $\varnothing 10$ ,  $\varnothing 12$ ,  $\varnothing 14$   
d G7:  $\varnothing 3/8$ " ( $\varnothing 9.52$ ),  $\varnothing 1/2$ " ( $\varnothing 12.7$ )

Clamping ring at B-side:  
Through hollow shaft, cable radial

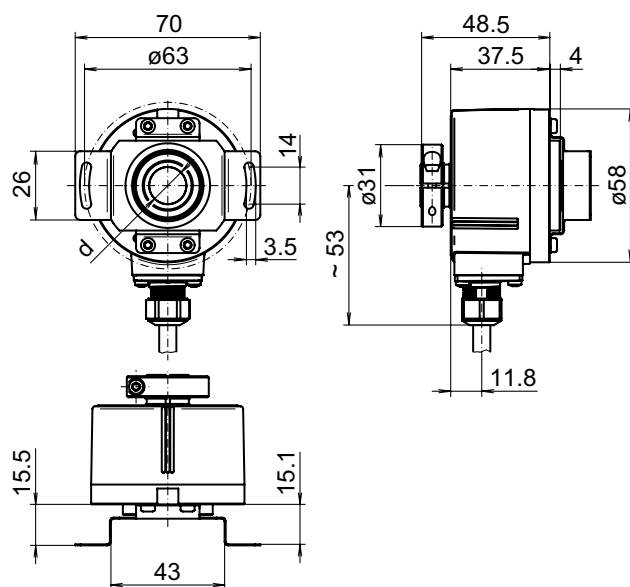

d H7:  $\varnothing 10$ ,  $\varnothing 12$ ,  $\varnothing 14$   
d G7:  $\varnothing 3/8$ " ( $\varnothing 9.52$ ),  $\varnothing 1/2$ " ( $\varnothing 12.7$ )

Flange version M:  
Mounting position torque support

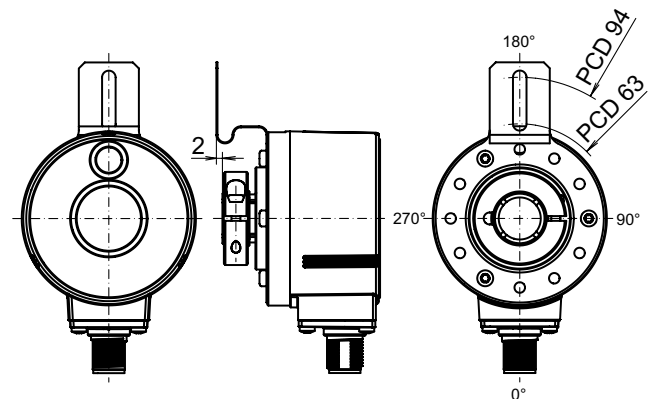

# Incremental encoders

With through hollow shaft

1...65536 pulses per revolution programmable (interpolated system)

EIL580P-T - *OptoPulse*<sup>®</sup>

## Dimensions

Flange version P:

Pin torque support, axial, clamping ring at A-side

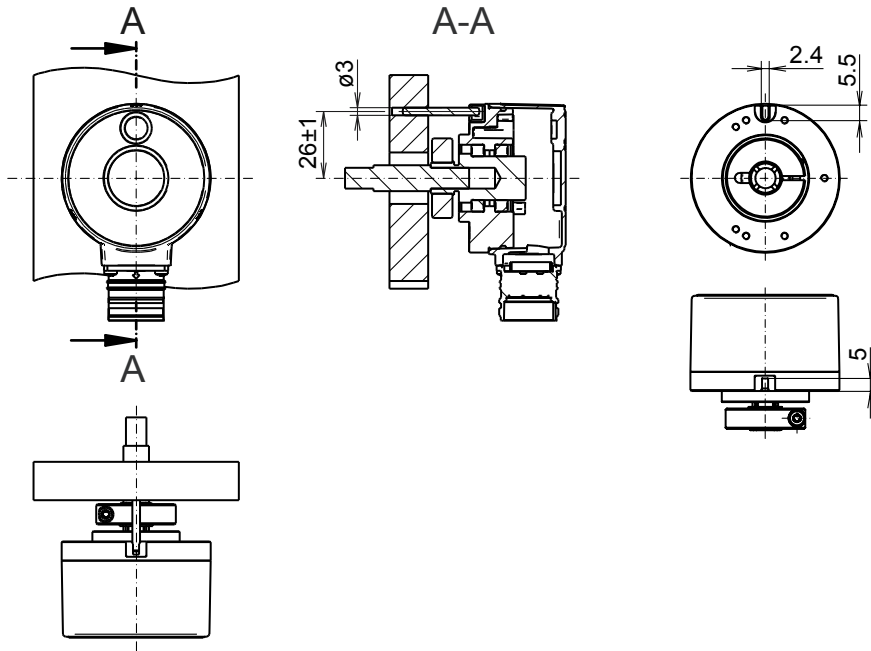

Clamping ring at A-side:  
Through hollow shaft

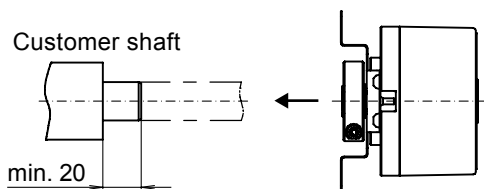

Clamping ring at B-side:  
Through hollow shaft

