

USER'S GUIDE

EE211 - Heated Humidity and Temperature Transmitter for High Humidity Applications

GENERAL

The EE211 is dedicated for accurate, long term stable measurement under high humidity and condensing conditions in demanding climate control. It features a heated humidity probe and an interchangeable temperature probe.

For use in special applications do not hesitate to contact E+E Elektronik or a local distributor.

ASSEMBLY

- Insert the PG20 cable gland included in the scope of supply into the corresponding opening of the EE211 basis unit and fix it tight with the nut. Alternatively, it is possible to install a 1/2" conduit fitting (not included in the scope of supply).
- Install the EE07-xT temperature probe either directly onto the M12 connector of the EE211 basis unit or using the optional probe cable.

SCOPE OF SUPPLY

EE211 Basis Device

- EE211 according ordering guide
- Cable gland M20 x 1.5
- Mounting materials
- Test report according according to DIN EN10204 - 3.1
- User Guide

EE07 Temperature Probe

- EE07 according ordering guide
- Test report according according to DIN EN10204 - 3.1

Cable for EE07 (optional)

CAUTION

- Make sure that the T Probe is properly connected. The absence of the T probe forces the analogue outputs into the upper limitation.
- The transmitter and mainly the sensing head of the probes shall not be exposed to extreme mechanical stress.
- The transmitter must be operated with the filter caps on at all times. Do not touch the sensors inside the sensing head.
- While replacing the filter cap (because of pollution for instance) against an original spare one please take very good care to not touch the sensors.

OPERATION PRINCIPLE

The humidity probe is continuously heated for avoiding condensation and high humidity side effects on the sensing elements, which leads to outstanding long term stability. Based on the measured values humidity and temperature, the EE211 calculates the dew point temperature T_d whereas the separate, interchangeable T-probe measures the ambient temperature. Ultimately, out of T_d and T , the device calculates the relative humidity RH as well as several other parameters like absolute humidity, mixing ratio, wet bulb temperature or enthalpy.

Outstanding long term stability under high humidity conditions

The operation principle of EE211 copes with the causes for poor long-term stability of non-heated sensors at continuously high humidity. The constant over-temperature of the EE211 sensing head (approx. $5\text{ °C} = 9\text{ °F}$) means max. 76 % RH humidity at the sensors and enables following benefits:

- The sensing head of EE211 stays dry even under condensing conditions, which prevents dust and dirt from sticking to the sensor and leads to **outstanding long-term stability**.
- The combination of dry sensing head, E+E proprietary coating of the sensing element and sealed solder pads **minimize the impact of corrosive agents**.
- Maximum humidity of 76 % RH at the sensor **eliminates the drift caused by exposure to continuous high humidity**.

Important:

The humidity related parameters correspond to the location of the T probe. Consequently, the T probe shall be positioned at the place of main interest for RH measurement. In an environmental chamber for instance, the EE211 basic device can be fixed conveniently on the inside wall, while the T probe can be placed in the middle of the chamber using the optional probe cable.

DIMENSIONS

Basis Device:

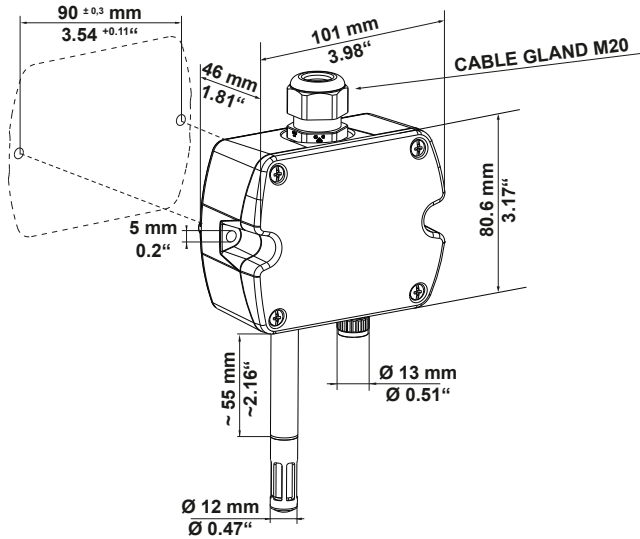

Temperature Probe:

Metal Housing EE07-MT

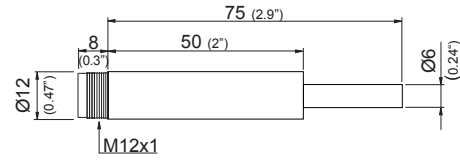

Polycarbonate Housing EE07-PT6

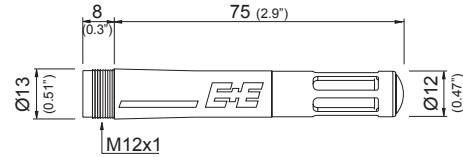

CONNECTION DIAGRAM

EE211-M1J3

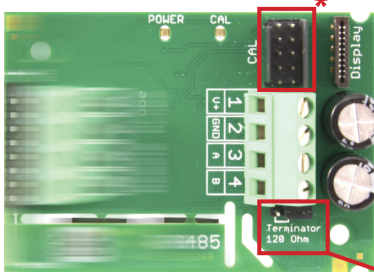

Bus termination resistor 120 Ω (jumper)

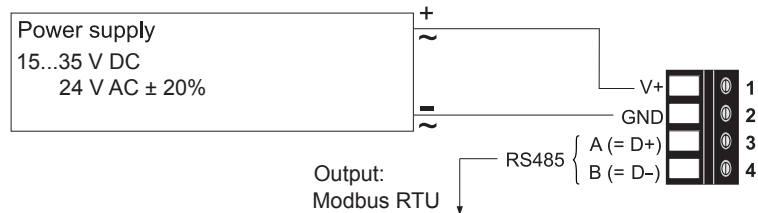

EE211-M1A2/3/5/6

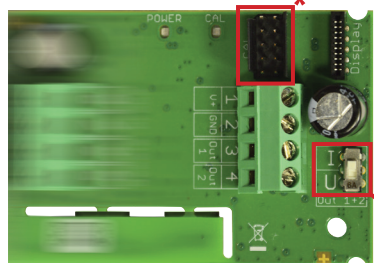

Selection output signal U / I

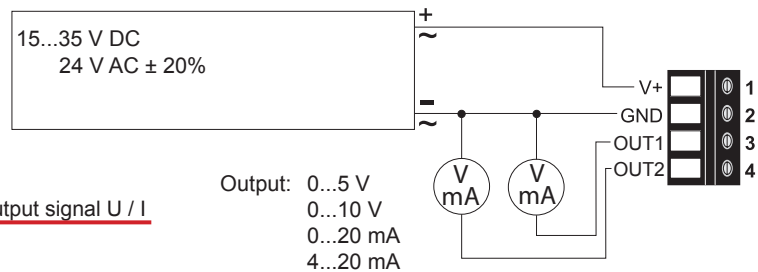

* configuration connector

LED INDICATION

Green LED - information during normal operation:

- on = everything OK
- flashing = the main board does not recognize the measurement electronics inside the RH probe
- off = no power supply or main board failure

Blue LED - information during setup with the optional E+E Product Configuration Adapter (EE-PCA):

- on = EE-PCA is powered, no communication in progress
- flashing = EE-PCA powered, communication in progress
- off = EE-PCA not connected to the EE210

DISPLAY

Factory Setup:

The display shows the two parameters selected for output 1 and output 2 (according to ordering code). For the Modbus version the display shows RH and T.

User Setup:

The user can change the display layout to 1, 2 or 3 lines and select the parameters to be displayed by using EE-PCS Product Configuration Software (free download from www.epluse.com/configurator) and the optional EE-PCA Product Configuration Adapter (not included in the scope of supply).

SELECTION OUTPUT SIGNAL U/I

The factory setup of the output signal and scaling corresponds to the type number as ordered.

The output signal (voltage or current 3-wire) can be selected with the DIP switch on the main electronics board (see picture PCB EE210-HT2/3/5/6). This does not impact on the scaling of the outputs, which can be changed using EE-PCA and EE-PCS.

Examples

Factory setup: voltage output 0-5 V or 0-10 V corresponds to 0...100% RH.

After switching from U to I: current output 4 ... 20mA (3-wire) corresponds to 0 ... 100% RH.

A change of the current output range for instance to 0-20 mA can be made subsequently with the EE-PCA and EE-PCS.

Factory setup: current output 0-20 mA or 4-20 mA (3-wire) corresponds to -10...50 °C.

After switching from I to U: voltage output 0-10 V corresponds to -10...50 °C.

A change of the voltage output range for instance to 0-5 V can be made subsequently with the EE-PCA and EE-PCS.

MODBUS SETTINGS

Modbus Setup

Address Switch

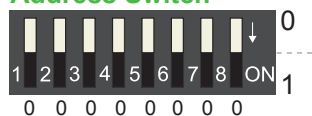

Slave address setting via EE-PCS Product Configuration Software:

All switches at position 0 → address has to be set via configuration software (factory setting 239).

Example: Slave address is set via configuration software.

Address Switch



Slave address setting via Dip-Switch:

Setting the Dip-Switch to any other address than 0 overwrites the slave address set via configuration software.

Example: Slave address set to 11 (=00001011 binary).

The measured values are saved as a 32 Bit float value from 0x19 to 0x1F and from 0x23 to 0x29. Additionally the measured values are available as 16 Bit signed integer from 0x12C to 0x12F and from 0x131 to 0x134.

The factory setting for the Slave-ID (Modbus address) is 239 as an integer 16 Bit value. This ID can be changed by the user in the register 60001 (0x00), permitted values are 1 - 247 permitted.

The serial number as ASCII-code is located at register address 30001-30008 (16 Bit per address).

The Firmware version is located at register address 30009 (Bit 15...8 = major release; Bit 7...0 = minor release).

The choice of measurement units (metric or non-metric) must be done in the ordering guide, see EE211 data sheet.

Switching from metric to non metric or vice versa by using the EE-PCS is not possible.

FLOAT (read register):			
Register address	Communication address	Parameter name	
30026	0x19	temperature	[°C], [°F]
30028	0x1B	relative humidity	[%]
30030	0x1D	water vapour partial pressure	[mbar], [psi]
30032	0x1F	dew point temperature	[°C], [°F]
30034	0x21	wet bulb temperature	[°C], [°F]
30036	0x23	absolute humidity	[g/m³], [g/ft³]
30038	0x25	mixing ratio	[g/kg], [gr/lb]
30040	0x27	specific enthalpy	[kJ/kg], [BTU/lb]
30042	0x29	frost point temperature	[°C], [°F]

INTEGER (read register):*			
Register address	Communication address	Parameter name	
30301	0x12C	temperature	[°C], [°F]
30302	0x12D	relative humidity	[%]
30303	0x12E	water vapour partial pressure	[mbar], [psi]
30304	0x12F	dew point temperature	[°C], [°F]
30305	0x130	wet bulb temperature	[°C], [°F]
30306	0x131	absolute humidity	[g/m³], [g/ft³]
30307	0x132	mixing ratio	[g/kg], [gr/lb]
30308	0x133	specific enthalpy	[kJ/kg], [BTU/lb]
30309	0x134	frost point temperature	[°C], [°F]

* Values are stored with a scaling of 1:100 (e.g.: 2550 is equivalent to 25.5°C)

INFO (read register):		
Register address	Communication address	Parameter name
30001	0x00	Serial number (as ASCII)
30009	0x08	Firmware version

INTEGER (write register):*		
Register address	Communication address	Parameter name
60001	0x00	Slave-ID (modbus adresse)
60002	0x01	Modbus protocol settings*

* For Modbus protocol setting please see Application Note Modbus (www.epluse.com/EE211)

Protocol setting:

Address, baudrate, parity and stop bits can be set via:

1. Product Configurator Software (available on www.epluse.com/EE211)
2. Modbus protocol (please see Application Note Modbus (available on www.epluse.com/EE211))

ACCESSORIES

- Product configuration adapter
- Product configuration software
- Power supply adapter
- Protection cap for 12 mm probe
- Metal grid filter cap

see data sheet EE-PCA

EE-PCS (free download: www.epluse.com)

V03 (see data sheet Accessories)

HA010783

HA010106 (see data sheet Accessories)

TECHNICAL DATA

(Modification rights reserved)

Relative Humidity (RH)

Sensor	E+E Sensor HCT01-00D
Working range	0...100 % RH
RH accuracy (incl. hysteresis, non-linearity and repeatability)	$\pm(1.3 + 0.007 \cdot \text{measured value})$ % RH
-5...30 °C (23...86 °F)	

Temperature (T)

Sensor	Pt1000 (tolerance class A, DIN EN 60751)
--------	--

T-accuracy
(at 20 °C (68 °F) : $\pm 0,1$ °C)

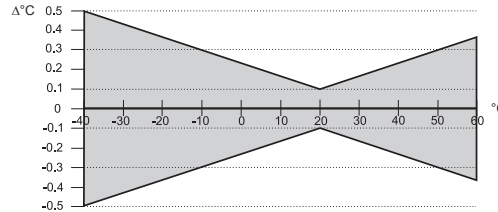



Outputs

Analogue output	0-5 V / 0-10 V	-1 mA < I_L < 1 mA
(RH: 0...100 %; T: see ordering guide)	0-20 mA / 4-20 mA (3-wire)	$R_L \leq 500$ Ohm

Digital output	RS485, Modbus RTU, max. 32 EE211 in one bus
-----------------------	---

General

Power supply (Class III) 	15 - 35 V DC ¹⁾ or 24 V AC ± 20 %	
Current consumption at 24 V		
Voltage output	DC supply max. 13 mA	with display max. 19 mA
	AC supply max. 38 mA _{rms}	with display max. 49 mA _{rms}
Current output	DC supply max. 34 mA	with display max. 40 mA
	AC supply typ. 75 mA _{rms}	with display typ. 85 mA _{rms}
Digital interface	DC supply typ. 8 mA	with display typ. 17 mA
	AC supply typ. 23 mA _{rms}	with display typ. 40 mA _{rms}
Display	1, 2 or 3 lines, user configurable, with backlight	
Connection	Screw terminals, max. 1.5 mm ²	
Housing material	Polycarbonate, UL94V-0 (with Display UL94HB) approved	
Protection class	IP65 / NEMA 4	
Cable gland	M20 x 1.5	
Sensor protection	E+E coating	
Electromagnetic compatibility	EN61326-1 EN61326-2-3, Industrial Environment 	
Temperature ranges	Operating / Storage: -40...60 °C (-40...140 °F)	
Temperature ranges with display	Operating: -20...50 °C (-4...122 °F)	
	Storage: -20...60 °C (-4...140 °F)	

1) USA & Canada: class 2 supply required, max. supply voltage 30V

SETUP

The EE211 transmitter is ready to use and does not require any configuration by the user. The factory setup of EE211 corresponds to the type number ordered. (Ordering guide please see data sheet at www.epluse.com/EE211.)

If needed, the user can change the factory setup by using the optional E+E Product Configuration Adapter (EE-PCA) and the E+E Product Configuration Software (EE-PCS).

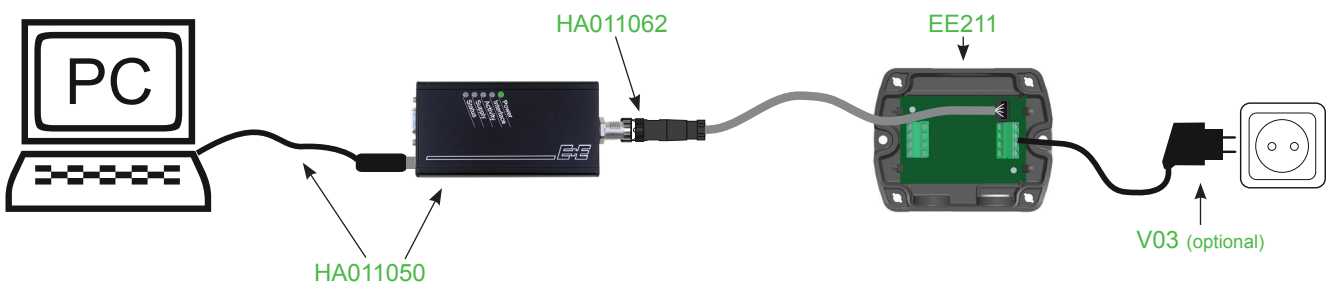

One can assign other physical quantities to the analogue outputs, change the scaling of the outputs, set the display and perform one or two point adjustment for humidity and temperature.

For product data sheet EE-PCA please see www.epluse.com.

The E+E Product Configuration Software (EE-PCS) is free and can be downloaded from www.epluse.com/configurator.

RH AND T ADJUSTMENT AND CALIBRATION

Definitions

Adjustment: the specimen is brought in line with the reference

Calibration: the specimen is compared with a reference and its deviation from the reference is documented

Calibration of the complete EE211 (incl. T probe)

- One point (offset) calibration/adjustment at ambient T can be easily performed by comparison with an adequate RH and a T reference. The E+E Omniport 20 handheld device can serve for instance as such reference. Omniport 20 can be optionally supplied with an accredited calibration certificate. See E+E calibration brochure at www.epluse.com.
- For multiple point calibration or 2-point adjustment for RH and T, the EE211 as a whole (both probes) shall be placed in a climate chamber.

Adjustment procedure

- Connect the EE211 to the a Windows PC using EE-PCA (not included in the scope of supply, see data sheet at www.epluse.com).
- EE-PCS (free download from www.epluse.com/configurator) shall be installed on the PC.
- Start EE-PCS and proceed with 1 or 2-point adjustment of the RH and of the T reading.

Please note: The adjustment data is stored in the main electronics board of the EE211, the factory adjustment of the heated humidity probe and of the T probe is not altered. In case of replacing of the EE07 T probe it is necessary to return to the factory setup of EE211.

Individual adjustment of the EE07 T Probe

The EE07 T Probe can be also adjusted separately, which might be desirable in high demanding applications. In such case, it is advisable to employ the EE07-MT probe (stainless steel enclosure), which is appropriate for best accuracy adjustment in a dry block calibrator. The EE07-PT (plastic enclosure) shall be calibrated / adjusted in the air.

Adjustment procedure

- Connect the EE07 temperature probe to the a Windows PC using EE-PCA (not included in the scope of supply, see data sheet at www.epluse.com)
- EE-PCS (free download from www.epluse.com/ee-configurator) shall be installed on the PC.
- Start EE-PCS and proceed with the calibration or adjustment of the T reading.

Please note: In case of individual adjustment, the adjustment data is stored in the EE07 T probe, the factory setup of the EE211 basis device is not altered. Consequently, the T probe can be readjusted or replaced or at any time without the need of readjusting the EE211 basis device.

MAINTENANCE

If needed, the sensing head of the humidity probe and of the EE07-PT probe can be cleaned by the user. The EE07-MT probe does not require any special cleaning because the temperature sensor is encapsulated in the stainless steel body of the probe. For cleaning instructions please see www.epluse.com.

USA

FCC notice:

This equipment has been tested and found to comply with the limits for a Class B digital device, pursuant to part 15 of the FCC Rules. These limits are designed to provide reasonable protection against harmful interference in a residential installation. This equipment generates, uses and can radiate radio frequency energy and, if not installed and used in accordance with the installation manual, may cause harmful interference to radio communications. However, there is no guarantee that interference will not occur in a particular installation. If this equipment does cause harmful interference to radio or television reception, which can be determined by turning the equipment off and on, the user is encouraged to try to correct the interference by one or more of the following measures:

- Reorient or relocate the receiving antenna.
- Increase the separation between the equipment and receiver.
- Connect the equipment into an outlet on a circuit different from that to which thereceiver is connected.
- Consult the dealer or an experienced radio/TV technician for help.

CANADIAN

ICES-003 Issue 5:

CAN ICES-3 B / NMB-3 B

INFORMATION

+43 7235 605 0 / info@epluse.com

Langwiesen 7 • A-4209 Engerwitzdorf
Tel: +43 7235 605-0 • Fax: +43 7235 605-8
info@epluse.com • www.epluse.com

LG Linz Fn 165761 t • UID-Nr. ATU44043101
Place of Jurisdiction: A-4020 Linz • DVR0962759

