

GRAPHIC OPERATION TERMINAL

MODEL

GT1030-HBD

QUICK START MANUAL



1. INTRODUCTION	3	7. WIRING	9
1.1 CAUTION.....	3	7.1 POWER SUPPLY WIRING	9
1.2 CERTIFICATION.....	4	7.2 WIRING INSIDE AND OUTSIDE THE PANEL.....	11
1.3 INCLUDED ITEMS	4	8. OPERATION SETTINGS	11
2. SPECIFICATIONS	5	8.1 RS-232/USB CONVERSION ADAPTOR.....	11
2.1 MODEL NAME EXPLANATION	5	8.2 BATTERY	15
2.2 GENERAL SPECIFICATIONS.....	5	8.3 UTILITY FUNCTION	15
2.3 PERFORMANCE SPECIFICATIONS.....	5	8.4 UTILITY DISPLAY	16
2.4 COMMUNICATION SPECIFICATIONS	6	8.5 COMMUNICATION INTERFACE SETTING	17
2.5 POWER SUPPLY SPECIFICATIONS.....	6	8.6 DATA TRANSFER	20
2.6 WIRING OF CONNECTION CABLE	6	8.7 COMMUNICATION MONITOR.....	20
3. HARDWARE SPECIFICATIONS	6	8.8 DISPLAY SETTINGS	21
4. EXTERNAL DIMENSIONS	7	8.9 OPERATION SETTING	23
5. RATING PLATE	7	8.10 CLOCK SETTINGS AND BATTERY STATUS DISPLAY.....	25
6. INSTALLATION AND REMOVAL	7	9. MAINTENANCE AND INSPECTION	25
6.1 CONTROL PANEL INSIDE DIMENSIONS FOR MOUNTING GOT.....	7	9.1 DAILY INSPECTION	26
6.2 PANEL CUTTING DIMENSIONS	7	9.2 PERIODIC INSPECTION.....	26
6.3 MOUNTING POSITION	8	9.3 CLEANING METHOD	26
6.4 CONTROL PANEL INSIDE TEMPERATURE AND MOUNTING ANGLE	8	10. WARRANTY	27
6.5 INSTALLATION PROCEDURE.....	8		

1. INTRODUCTION

This manual describes the specifications of the product. Before use, read this manual and manuals of relevant products fully to acquire proficiency in handling and operating the product. Make sure to learn all the product information, safety information, and precautions. And, store this manual in a safe place so that you can take it out and read it whenever necessary. Always forward it to the end user.

Registration

The company name and the product name to be described in this manual are the Registered trademarks or trademarks of each company.



Effective April 2015

Specifications are subject to change without notice.

© 2008 MITSUBISHI ELECTRIC CORPORATION

1.1 CAUTION

Safety Precaution (Read these precautions before use.) This manual classifies the safety precautions into two categories: **DANGER** and **CAUTION**.

-  **DANGER** Indicates that incorrect handling may cause hazardous conditions, resulting in death or severe injury.
-  **CAUTION** Indicates that incorrect handling may cause hazardous conditions, resulting in medium or slight personal injury or physical damage.

Depending on the circumstances, procedures indicated by **CAUTION** may also cause severe injury. It is important to follow all precautions for personal safety.

DANGER DESIGN PRECAUTIONS

- Some failures of the GOT or cable may keep the outputs on or off. An external monitoring circuit should be provided to check for output signals which may lead to a serious accident. Not doing so can cause an accident due to false output or malfunction.
- If a communication fault (including cable disconnection) occurs during monitoring on the GOT, communication between the GOT and PLC CPU is suspended and the GOT becomes inoperative. A system where the GOT is used should be configured to perform any significant operation to the system by using the switches of a device other than the GOT on the assumption that a GOT communication fault will occur. Not doing so can cause an accident due to false output or malfunction.
- Do not use the GOT as the warning device that may cause a serious accident. An independent and redundant hardware or mechanical interlock is required to configure the device that displays and outputs serious warning. Failure to observe this instruction may result in an accident due to incorrect output or malfunction.
- Incorrect operation of the touch switch(s) may lead to a serious accident if the GOT backlight is gone out. When the GOT backlight goes out, causes the monitor screen to appear blank, while the input of the touch switch(s) remains active. This may confuse an operator in thinking that the GOT is in "screensaver" mode, who then tries to release the GOT from this mode by touching the display section, which may cause a touch switch to operate.

CAUTION DESIGN PRECAUTIONS

- Do not bundle the control and communication cables with main-circuit, power or other wiring. Run the above cables separately from such wiring and keep them a minimum of 100mm (3.94 in.) apart.

Not doing so noise can cause a malfunction.

- Do not press the GOT display section with a pointed material as a pen or driver. Doing so can result in a damage or failure of the display section.
- Before connecting to GOT, turn ON the controller to enable the communication. When the communication of controller is not available, a communication error may occur in GOT.

DANGER MOUNTING PRECAUTIONS

- Be sure to shut off all phases of the external power supply used by the system before mounting or removing the GOT to/from the panel. Not doing so can cause the unit to fail or malfunction.
- When installing the battery wear an earth band etc. to avoid the static electricity. The static electricity can cause the unit to fail or malfunction.

CAUTION MOUNTING PRECAUTIONS

- Use the GOT in the environment that satisfies the general specifications described in this manual. Not doing so can cause an electric shock, fire, malfunction or product damage or deterioration.
- When mounting the GOT to the control panel, tighten the mounting screws in the specified torque range. Undertightening can cause the GOT to drop, short circuit or malfunction, and deteriorate the waterproof effect and oilproof effect.
- Overtightening can cause a drop, short circuit or malfunction due to the damage of the screws or the GOT, and deteriorate the waterproof effect and oilproof effect due to distortion of the protective cover for oil, GOT or panel.
- When using the GOT in the environment of oil or chemicals, use the protective cover for oil. Failure to do so may cause failure or malfunction due to the oil or chemical entering into the GOT.

DANGER WIRING PRECAUTIONS

- Be sure to shut off all phases of the external power supply used by the system before wiring. Failure to do so may result in an electric shock, product damage or malfunctions.
- Please make sure to ground FG terminal of the GOT power supply section by applying 100 or less which is used exclusively for the GOT. Not doing so may cause an electric shock or malfunction.
- Correctly wire the GOT power supply section after confirming the rated voltage and terminal arrangement of the product. Not doing so can cause a fire or failure.
- Tighten the terminal screws of the GOT power supply section in the specified torque range. Undertightening can cause a short circuit or malfunction. Overtightening can cause a short circuit or malfunction due to the damage of the screws or the GOT.
- Exercise care to avoid foreign matter such as chips and wire offcuts entering the GOT. Not doing so can cause a fire, failure or malfunction.

CAUTION WIRING PRECAUTIONS

- Plug the communication cable into the connector of the connected unit and tighten the mounting and terminal screws in the specified torque range. Undertightening can cause a short circuit or malfunction. Overtightening can cause a short circuit or malfunction due to the damage of the screws or unit

DANGER TEST OPERATION PRECAUTIONS

- Before performing the test operations of the user creation monitor screen (such as turning ON or OFF bit device, changing the word device current value, changing the settings or current values of the timer or counter), read through the manual carefully and make yourself familiar with the operation method. During test operation, never change the data of the devices which are used to perform

significant operation for the system. False output or malfunction can cause an accident..

DANGER STARTUP/MAINTENANCE PRECAUTIONS

- When power is on, do not touch the terminals. Doing so can cause an electric shock or malfunction.
- Connect the battery correctly. Do not discharge, disassemble, heat, short, solder or throw the battery into the fire. Incorrect handling may cause the battery to generate heat, burst or take fire, resulting in injuries or fires.
- Before starting cleaning or terminal screw retightening, always switch off the power externally in all phases. Not switching the power off in all phases can cause a unit failure or malfunction. Undertightening can cause a short circuit or malfunction. Overtightening can cause a short circuit or malfunction due to the damage of the screws or unit.

CAUTION STARTUP/MAINTENANCE PRECAUTIONS

- Do not disassemble or modify the unit. Doing so can cause a failure, malfunction, injury or fire.
- Do not touch the conductive and electronic parts of the unit directly. Doing so can cause a unit malfunction or failure.
- The cables connected to the unit must be run in ducts or clamped. Not doing so can cause the unit or cable to be damaged due to the dangling, motion or accidental pulling of the cables or can cause a malfunction due to a cable connection fault.
- When unplugging the cable connected to the unit, do not hold and pull the cable portion. Doing so can cause the unit or cable to be damaged or can cause a malfunction due to a cable connection fault.
- Do not drop or apply any impact to the battery. If any impact has been applied, discard the battery and never use it. The battery may be damaged by the drop or impact.
- Before touching the unit, always touch grounded metal, etc. to discharge static electricity from human body, etc. Not doing so can cause the unit to fail malfunction.
- Replace battery with GT11-50BAT by Mitsubishi electric Co. only. Use of another battery may present a risk of fire or explosion.
- Dispose of used battery promptly. Keep away from children. Do not disassemble and do not dispose of in fire.

CAUTION DISPOSAL PRECAUTIONS

- When disposing of the product, handle it as industrial waste.
- When disposing of batteries, separate them from other wastes according to the local regulations.

CAUTION TRANSPORTATION PRECAUTIONS

- For the analog-resistive film type touch panels, normally the adjustment is not required. However, the difference between a touched position and the object position may occur as the period of use elapses. When any difference between a touched position and the object position occurs, execute the touch panel calibration.
- When any difference between a touched position and the object position occurs, other object may be activated. This may cause an unexpected operation due to incorrect output or malfunction.

CAUTION TRANSPORTATION PRECAUTIONS

- When transporting lithium batteries, make sure to treat them based on the transport regulations.
- Before transporting the GOT, turn the GOT power on and check that the battery voltage status is normal on the Time setting & display screen (utilities screen). In addition, confirm that the adequate battery life remains on the rating plate. Transporting the GOT with the low battery voltage or the battery the reached battery life may destabilize the backup data unstable during transportation.

- Make sure to transport the GOT main unit and/or relevant unit(s) in the manner they will not be exposed to the impact exceeding the impact resistance described in the general specifications of this manual, as they are precision devices. Failure to do so may cause the unit to fail. Check if the unit operates correctly after transportation.

1.2 CERTIFICATION

Compliance with EC directive (CE Marking)

This note does not guarantee that an entire mechanical module produced in accordance with the contents of this note will comply with the following standards. Compliance to EMC directive for the entire mechanical module should be checked by the user / manufacturer. For more details please contact Mitsubishi Electric at AZsupport@meau.com.

- This product is designed for use in industrial applications.
- Authorized Representative in the European Community:
Mitsubishi Electric Europe B.V.
Gothaer Str. 8, 40880 Ratingen, Germany

Requirement for Compliance with EMC directive

The following products have shown compliance through direct testing (to the identified standards) and design analysis (forming a technical construction file) to the European Directive for Electromagnetic Compatibility (2004/108/EC) when used as directed by the appropriate documentation. Type :Programmable Controller (Open Type Equipment)

Standard		Remark
EN61131-2 : 2007 Programmable controllers- Equipment, requirement and tests	EMI	Compliance with all relevant aspects of the standard. (Radiated Emissions)
	EMS	Compliance with all relevant aspects of the standard. (ESD, RF electromagnetic field, EFTB, Surge, RF conducted disturbances and Power frequency magnetic field)

Notes for compliance to EMC regulation

- General notes on the use of communication cables Any device which utilizes a data communication function is susceptible to the wider effects of local EMC noise. Therefore, when installing any communication cables care should always be taken with the routing and location of those cables. The GOT units identified on the previous chapter are compliant with the EMC requirement when the following communication cables are used.

GOT Unit	Existing Cables
GT1030-HBD	GT10-C30R4-8P (For Melsec FX series PLC)

General notes on Power supply

General notes on the use of the power cable The GT1030-HBD unit demand that the cable for the power supply is 10m or less.

1.3 INCLUDED ITEMS

Product Name	Model Name	Specifications
GOT	GT1030-HBD	GOT main unit (The maintenance supplies below are packed with the product.)

Item	Quantity
PLC Communication Connector	1
Panel Mounting Bracket (with M4 X 20 screws)	4
Panel Mounting Packing	1
GT10 General Description Manual	1

2. SPECIFICATIONS

2.1 MODEL NAME EXPLANATION

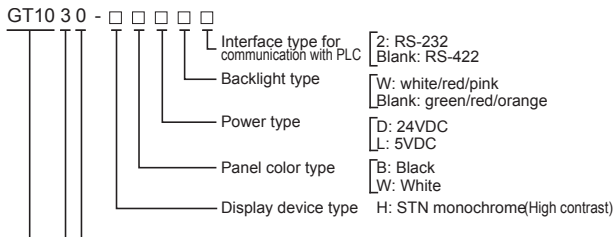

2.2 GENERAL SPECIFICATIONS

Item	Specifications					
Operating Ambient Temp.	Display Section 0 to 50°C					
	Other Than Display Section 0 to 55°C (When mounted horizontally), 0 to 50°C (When mounted vertically)					
Storage Ambient Temperature	-20 to 60°C					
Operating/Storage Ambient Humidity	10 to 90% RH, non-condensing (The wet bulb temperature is 39°C or less.)					
Vibration Resistance	Conforms to JIS B3502 and IEC61131-2	Frequency	Acceleration	Half-amplitude	Sweep Count 10 times each in X, Y and Z directions	
		Under intermittent vibration	5 to 8.4Hz 8.4 to 150Hz	- 9.8m/s ²		3.5mm -
		Under continuous vibration	5 to 8.4Hz 8.4 to 150Hz	- 4.9m/s ²		1.75mm -
Shock Resistance	Conforms to JIS B3502, IEC 61131-2 (147 m/s ² , 11 ms, Sine half-wave pulse, 3 times each in the X, Y, and Z directions.)					
Operating Atmosphere	Must be free of lamp black, corrosive gas, flammable gas, or excessive amount of electro conductive dust particles and must be no direct sunlight. (Same as for saving)					
Operating Altitude *1	2000m (6562 ft.) max.					
Installation Location	Inside control panel					
Overvoltage Category *2	II or less					
Pollution Degree *3	2 or less					
Cooling Method	Self-cooling					

- Do not use or store the GOT under pressure higher than the atmospheric pressure of altitude 0m (0ft.). Failure to observe this instruction may cause a malfunction. When the air inside the control panel is purged by pressurization, the surface sheet may be lifted by high pressure. As a result, the touch panel may be difficult to press, and the sheet may be peeled off.
- This indicates the section of the power supply to which the equipment is assumed to be connected between the public electrical power distribution network and the machinery within the premises. Category II applies to equipment for which electrical power is supplied from fixed facilities. The surge voltage withstand level for up to the rated voltage of 300 V is 2500 V.
- This index indicates the degree to which conductive material is generated in the environment where the equipment is used. In pollution degree 2, only non-conductive pollution occurs but temporary conductivity may be produced due to condensation where the equipment is used. In pollution degree 2, only non-conductive pollution occurs but temporary conductivity may be produced due to condensation.

2.3 PERFORMANCE SPECIFICATIONS

Item	GT1030-HBD	
Display Section *1	Type	STN monochrome (white/black) liquid crystal
	Screen Size	4.5"
	Resolution	288 x 96 dots (Horizontal format)
	Display Size (WxH)	109.42 x 35.98 (4.3 x 1.41) mm (inch) (Horizontal format)
	Display Character	16-dot standard font: 36 characters x 6 lines, 12-dot standard font: 48 characters x 8 lines (Horizontal format)
	Display Color	Monochrome (white/black)
	Display Angle	Left/Right: 30 degrees, Top: 20 degrees, Bottom: 30 degrees (Horizontal format)
	Contrast Adjust.	16-level adjustment
	Intensity of LCD Only	200 [cd/m ²] (in green)
	Intensity Adjustment	8-level adjustment
	Life	Approx. 50,000h. (Time for display intensity to become 1/5 at operating ambient temperature of 25°C)

Backlight	Type	LED with 3 available colors (green, red, orange)
	Life	Backlight status (colors, ON/BLINK/OFF) control, Adjustable screensaver activation time Setting the system information enables *2 PLC to control the backlight status
Touch Panel	Number of Touch Keys	Maximum 50 keys/screen (Matrix resistive film touch panel)
	Key size	Minimum 16 x 16 dots (per key)
	Simultaneous Pressing of Two (or more) Areas (2-point press)	Enable
	Life	1 million times or more (operating force 0.98N max.)

Item	GT1030-HBD	
Memory	C Drive	Flash memory ROM (Internal), for storing project data (1.5M bytes or less), OS
	Life	Life (Number of write times)
	D Drive	SRAM (Internal), for storing alarm history, recipe data and time action setting value
Battery	Model	GT11-50BAT lithium battery
	Type	Magnesium manganese dioxide lithium primary battery
	Backup Target	Clock data, alarm history and recipe data
	Life	Approx. 5 years (Operating ambient temperature of 25°C)
Buzzer Output (a buzzer that sounds when touch keys are pressed)	Single tone (LONG/ SHORT/ OFF adjustable)	
Environmental Protective Structure *4	Equivalent to IP67 (JEM1030) (front section)	
External Dimensions W x H x D mm (inch)	145 x 76 x 29.5 (5.7 x 2.99 x 1.16) (Excluding mounting fixtures) (Horizontal format)	
Panel Cutting Dimensions (W x H)	137 x 66 (5.39 x 2.59) mm (inch) (Horizontal format)	
Weight	0.3kg	
Compatible Software Package	GT Designer3 Version1.19V or later	

- Bright dots (always lit) and dark dots (unlit) may appear on a liquid crystal display panel. It is impossible to completely avoid this symptom, as the liquid crystal display comprises of a great number of display elements. Flickers may be observed depending on the display color. Please note that these dots appear due to its characteristic and are not caused by product defect.
- Flickers and partial discoloration may be generated on the liquid crystal display panel due to the display contents or the contrast adjustment. However, please note that these phenomena appear due to its characteristic and are not caused by product defect.
- There is a difference in the display brightness and the color tones between liquid crystal display panels. When using multiple liquid crystal display panels, please note that there is an individual difference between them.
- A crosstalk (shadow as an extension of the display) may appear on the liquid crystal display panel. Please note that it appears due to its characteristic.
- When the display section is seen from the outside of the display angle, the display color seems like it has changed. Please note that it is due to its characteristic. Please note that the response time, brightness and color of the liquid crystal display panel may vary depending on the usage environmental temperature. Especially in the low temperature environment, the display response becomes slow due to the characteristics of the STN liquid crystal. Please check the display response in advance for using this product.
- Please note that the response in low temperatures tend to be slower as a characteristic of the liquid crystal display panel.
- When the same screen is displayed for a long time, an incidental color or partial discoloration is generated on the screen due to heat damage, and it may not disappear.
- To prevent heat damage, the screen saver function is effective.
- For the details of system information, refer to the following GT Designer3 Version1 Screen Design Manual
- ROM in which new data can be written without deleting the written data.
- Note that this does not guarantee all users' operation environment. In addition, the product may not be used in environments under exposition of oil or chemicals for a long period of time, or in environments filled with oil-mist.

2.4 COMMUNICATION SPECIFICATIONS

Item	GT1030-HBD	
PLC Communication	Communication Standard	RS-422/485 1ch
	Transmission Speed	115,200/57,600/38,400/19,200/9,600/4,800bps
	Connector Shape	Connector terminal block 9-pins
PC Communication *2	Communication Standard	RS-232 1ch
	Transmission Speed	115,200/57,600/38,400/19,200/9,600/4,800bps
	Connector Shape	MINI DIN 6-pins (Female)

1. Set the terminating resistor selector switch of the GOT in accordance with the connection type when adopting GOT multidrop connection.
2. Project data upload/download, OS installation, Transparent function

2.5 POWER SUPPLY SPECIFICATIONS

	GT1030-HBD
Input Power Supply Voltage	24VDC (+10% -15%) ripple voltage 200mV or less
Fuse (Built-in, Not Exchangeable)	0.5A
Power Consumption (At Backlight Off)	2.2W (90mA/24VDC) or less, (1.7W (70mA/24VDC) or less)
Inrush current	18A or less (26.4VDC) 1ms
Permissible Instantaneous Power Failure Time *1	Within 5ms
Noise Immunity	Noise voltage: 1000Vp-p, Noise width: 1μs (by noise simulator of 30 to 100Hz noise frequency)
Dielectric Withstand Voltage	500VAC for 1 minute (between the GOT's power supply terminals and the GOT's grounding terminal)
Insulation Resistance	10MΩ or larger by insulation resistance tester (between the GOT's power supply terminals and the GOT's grounding terminal)
Grounding	Class D grounding (100Ω or less). To be connected to the panel when grounding is not possible

*1 The GOT continues to operate even upon 5ms or shorter instantaneous power failure. The GOT stops operating if there is extended power failure or voltage drop, while it automatically resumes operation as soon as the power is restored.

2.6 WIRING OF CONNECTION CABLE

The diagram below shows cable assignment for GOT port.
Cables: GT10-C__R4-8P, GT10-C__R4-2P, GT10-C__R2-6P

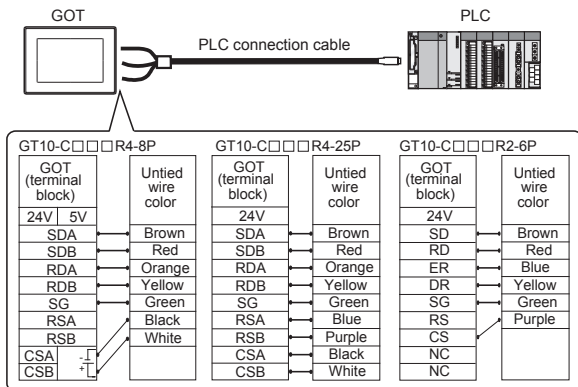

User-made cable is necessary, depending on the PLC.

3. HARDWARE SPECIFICATIONS

FRONT PANEL

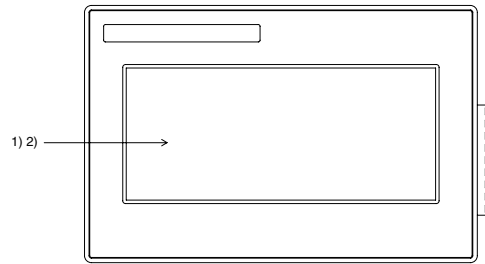

No.	Name	Description
(1)	Display Screen	Displays the utility screen and the user creation screen. GT1030: 288 x 96 dots, STN monochrome (white/black) liquid crystal
(2)	Touch Key	For operating the touch switches in the utility screen and the user creation screen

BACK PANEL

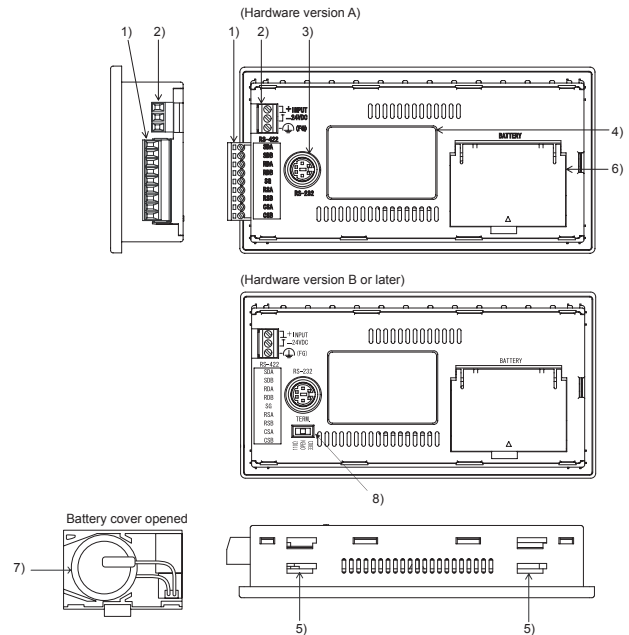

No.	Name	Description
(1)	PLC connection interface (RS-422)	For connection to a controller (PLC) (9-pin connector terminal block)
(2)	Power terminal	24VDC (+10% -15%)
(3)	PC connection interface (RS-232)	For PC connection (OS installation, Project data, download, transparent) (MINI-DIN 6 pins, female)
(4)	Rating plate (nameplate)	-
(5)	Hole for unit installation fitting	Hole for mounting fitting (supplied) to mount the GOT on the panel (4 holes at the top and bottom)
(6)	Battery cover	Open or close when replacing the battery.
(7)	Battery	GT11-50BAT battery for storing clock data, alarm history, recipe data and time action setting value (The project data is stored in the built-in flash memory.)
(8)	Terminating resistor selector switch (TERM.)	Terminating resistor selector of RS422/485 (330Ω/OPEN/110Ω) (At factory shipment: 330Ω)

4. EXTERNAL DIMENSIONS

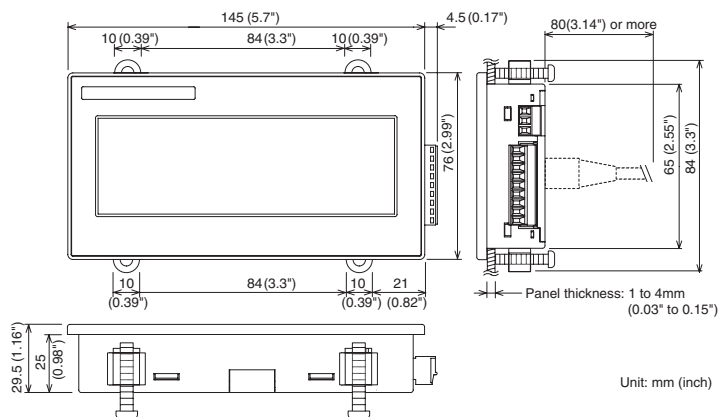

5. RATING PLATE

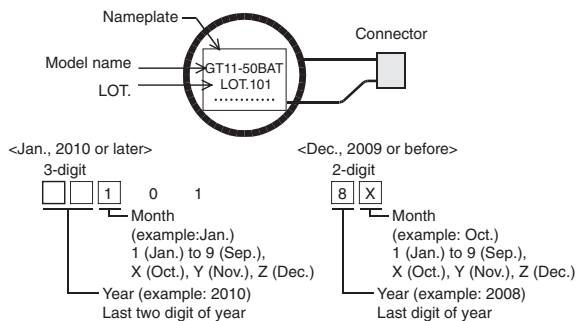
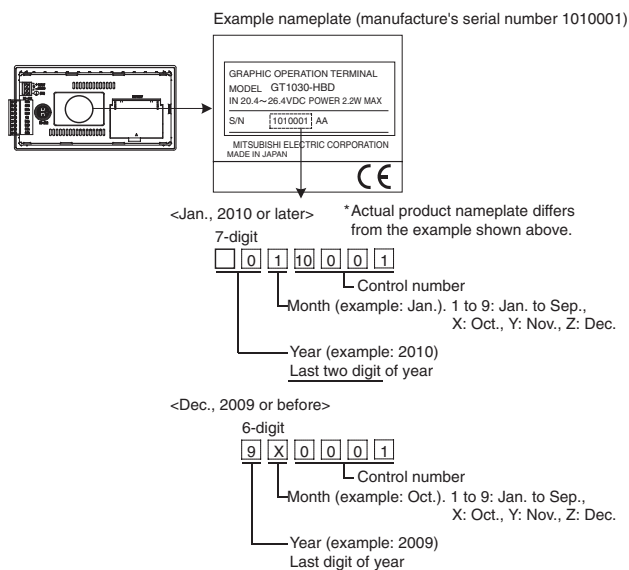

How to confirm production year and month

The production date of the optional replacement battery can be confirmed by the lot No. marked on the nameplate (label) affixed on the battery.

6. INSTALLATION AND REMOVAL

6.1 CONTROL PANEL INSIDE DIMENSIONS FOR MOUNTING GOT

Mount the GOT onto the control panel while considering the following control panel inside dimensions.

Horizontal format

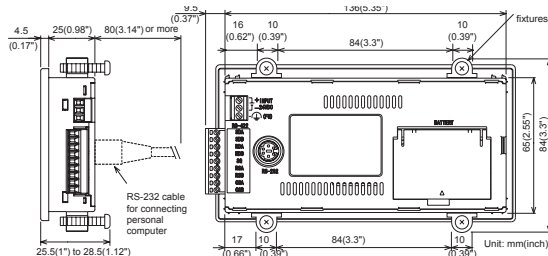

Vertical format

(If the vertical format is selected, the dimension, which is rotated 90 degrees clockwise looking from the display section side, is required.)

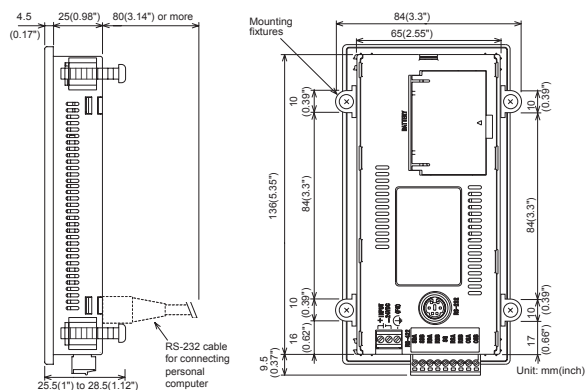

Applicable cable

Some cables may need to be longer than the specified dimensions when connecting to the GOT. Therefore, consider the connector dimensions and bending radius of the cable as well for installation.

6.2 PANEL CUTTING DIMENSIONS

Cut holes in the following dimensions on the panel. A space of top and bottom is required to allow for the attachment of mounting fixtures.

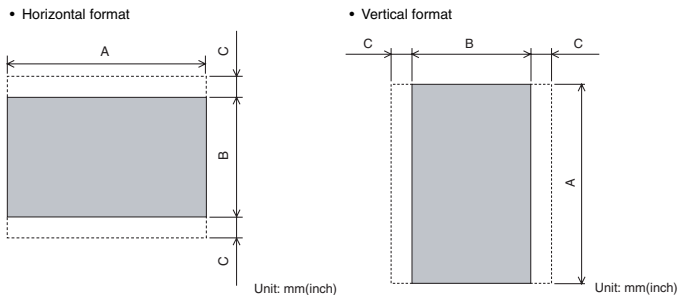

GOT	A	B	C	Panel Thickness mm (inch)
GT1030	137(5.39") (+1(0.03"), 0(0))	66(2.59") (+1(0.03"), 0(0))	13(0.51") or more	Within 1(0.03") to 4(0.15")

6.3 MOUNTING POSITION

When mounting the GOT, the following clearances must be maintained from other structures and devices.

Horizontal position

Installation Environment	A	B	C	D	E
In the presence of radiated-noise or heat-generating equipment nearby	50 mm (1.97") or more	50 mm (1.97") or more	50 mm (1.97") or more*2	50 mm (1.97") or more	80 mm (3.14") or more *1
In the absence of radiated-noise or heat-generating equipment nearby	20 mm (0.79") or more	20 mm (0.79") or more	20 mm (0.79") or more		20 mm (0.79") or more

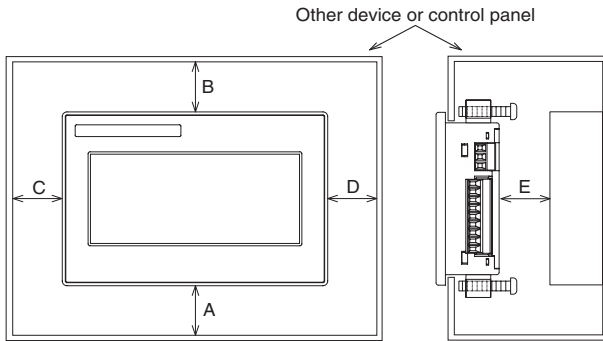

Vertical position

Installation Environment	A	B	C	D	E
In the presence of radiated-noise or heat-generating equipment nearby	50 mm (1.97") or more	50 mm (1.97") or more	50 mm (1.97") or more	50 mm (1.97") or more	80 mm (3.14") or more *1
In the absence of radiated-noise or heat-generating equipment nearby		20 mm (0.79") or more	20 mm (0.79") or more	20 mm (0.79") or more	20 mm (0.79") or more

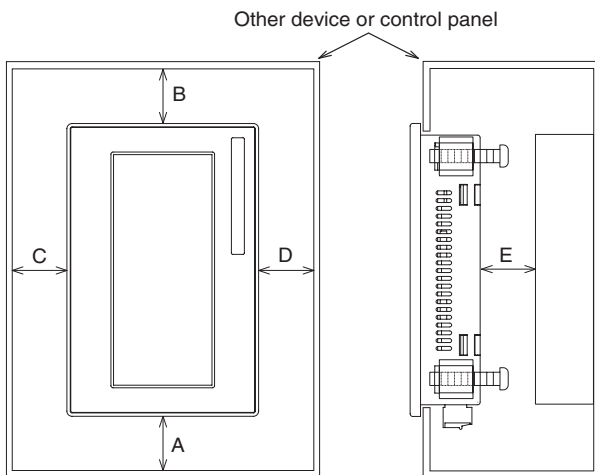

6.4 CONTROL PANEL INSIDE TEMPERATURE AND MOUNTING ANGLE

When mounting the main unit to a control panel or similar fixture, set the GOT display section as shown below.

Horizontal installation

When the temperature inside the control panel is 40° to 55°, the mounting angle should be in the range from 60 to 105 degrees.

Vertical installation

When the temperature inside the control panel is 40° to 50°, the mounting angle should be in the range from 60 to 105 degrees.

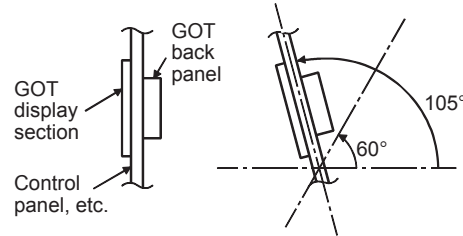

The GOT will have a longer lifetime if used within the mounting angles shown above. Ideally, the temperature inside the control panel should not exceed 0 to 40°C

6.5 INSTALLATION PROCEDURE

The GOT is designed to be embedded into a panel. Mount the GOT by following the procedure below.

Cautions on the installation panel

Make sure that the panel surface is free from warpage, flaws and irregularities. Warpage, flaws and irregularities may disable the waterproof effect. Select proper panel thickness under consideration of the panel strength. (For example, the panel strength may be insufficient depending on the panel material and dimensions even if the panel thickness is acceptable. Insufficient panel strength may cause warpage depending on the installation positions of the GOT and other equipment.) Installing the packing Install packing to the packing installation groove on the back panel of the GOT. While referring to the cross sectional view of the packing shown right, push the thinner side into the packing groove. (Drawing below is the example of lateral format.)

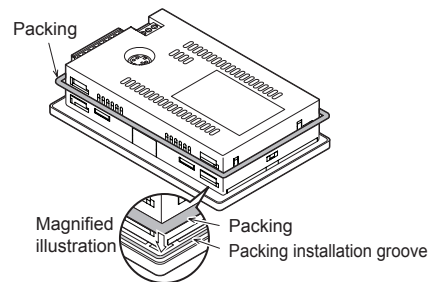

Installing the packing

Install packing to the packing installation groove on the back panel of the GOT

Inserting into the panel face

Insert the GOT from the front side of the panel. (Drawing at right is the example of lateral format.)

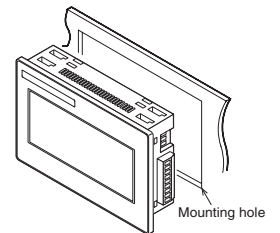

Fixing the GOT

1. Insert the hooks on the mounting fittings (supplied) into the mounting holes on the GOT unit.
2. Slide the mounting fittings to the back end.
3. Slide them to the left to lock them in place, and then fix them with the mounting screws (supplied).

The GOT will be fixed in 4 upper/lower parts.

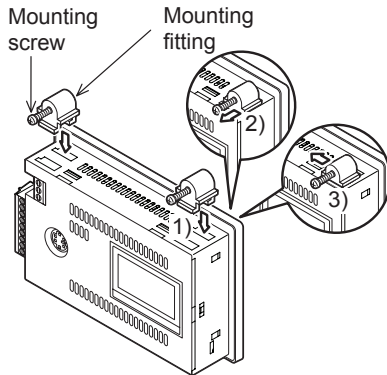

Cautions on installation

Tighten the mounting screw with the specified torque. Undertightening of mounting screws can cause a drop, and deteriorate the waterproof effect and oilproof effect. Failure to do so may damage the unit, or distort the panel and make a surface waviness on the display area, leading to deterioration of the visibility or incorrect input from the touch panel. In addition, the waterproof effect and oilproof effect may not be available due to the "distortion" of GOT or panel.

GT1030 Tightening Torque: 0.20 to 0.25 N•m

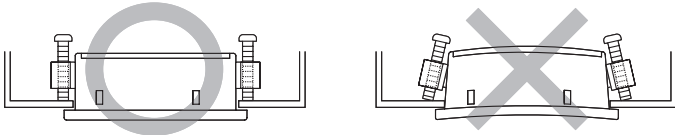

A protection film is attached on the display section of GOT prior to shipment. Remove the film when the installation is completed.

7. WIRING

DANGER WIRING PRECAUTIONS

- Be sure to shut off all phases of the external power supply used by the system before wiring. Failure to do so may result in an electric shock, product damage or malfunctions.
- Please make sure to ground FG terminal of the GOT power supply section by applying 100 or less which is used exclusively for the GOT. Not doing so may cause an electric shock or malfunction.
- Correctly wire the GOT power supply section after confirming the rated voltage and terminal arrangement of the product. Not doing so can cause a fire or failure.
- Tighten the terminal screws of the GOT power supply section in the specified torque range. Undertightening can cause a short circuit or malfunction. Overtightening can cause a short circuit or malfunction due to the damage of the screws or the GOT.
- Exercise care to avoid foreign matter such as chips and wire offcuts entering the GOT. Not doing so can cause a fire, failure or malfunction.

CAUTION WIRING PRECAUTIONS

- Plug the communication cable into the connector of the connected

unit and tighten the mounting and terminal screws in the specified torque range. Undertightening can cause a short circuit or malfunction. Overtightening can cause a short circuit or malfunction due to the damage of the screws or unit.

■ GENERAL PREVENTIVE MEASURES AGAINST NOISE

There are two kinds of noises: Radiated noise that is transmitted into the air and conductive noise that is directly transmitted along connected lines. Countermeasures must be taken considering both kinds of noises and referring to the following 3 points.

1. Protecting against noise
 - ▶ Keep signal lines away from noise sources such as a power cable or a high power drive circuit.
 - ▶ Shield the signal lines.
2. Reducing generated noise
 - ▶ Use a noise filter, etc. to reduce the level of the noise generated due to a source such as a high-power motor drive circuit.
 - ▶ Attach surge killers to the terminals on the no fuse breakers (NFB), electromagnetic contactors, relays, solenoid valves, and generators to suppress noise interference.
3. Releasing noise to the ground
 - ▶ Make sure to connect the ground cable to the ground.
 - ▶ Use a short and thick cable to lower its ground resistance.
 - ▶ Ground the power system and the control system separately.

7.1 POWER SUPPLY WIRING

Connect the power supply to the power terminals on the back panel of the GOT. Use a specified size power supply wire to prevent voltage drop, and tighten the terminal screws firmly to a specified torque. Do not exceed the number of wires that are allowed to be connected. Secure the wires to prevent stress from being directly applied to the terminal block or wire connections. In the case of GT1030-_, GOT power is supplied via the communication cable.

Process the end of the electrical wire (solid or stranded), or attach a ferrules with plastic sleeve to the wire end. Terminal screws should be tightened to between 0.22 to 0.25 N•m. Terminal screws must be secured to prevent a loose connection thus avoiding a malfunction. Failure to do so may cause equipment failures or malfunctions.

Electrical wire size

No. of Wire Per Terminal	Electrical Wire Size		
	Solid Wire	Stranded Wire	Ferrules with Plastic Sleeve
1	0.14 to 1.5mm ² AWG26 to AWG16	0.14 to 1.0mm ² AWG26 to AWG16	0.25 to 0.5 mm ² AWG24 to AWG20
2	0.14 to 0.5mm ² AWG26 to AWG20	0.14 to 0.2mm ² AWG26 to AWG24	-

Wire end processing

1. Connecting the wire directly
 - ▶ Twist the end of the stranded wire. Make sure there are no wire whiskers.
 - ▶ Do not solder the wire end.

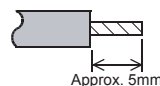

2. Using a ferrules with plastic sleeve to connect the wire
 A wire with a too thick of a wire sheath may not fit the insulation sleeve. Refer to the outline drawing for how to select the proper size wire.

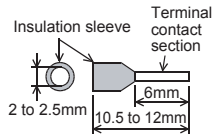

Manufacturer	Model Name	Crimper Type
Phoenix Contact Inc.	AI 0.25-6BU (AWG24)	CRIMPFOXZA3
	AI 0.34-6TQ (AWG22)	
	AI 0.5-6WH (AWG20)	

Tools

Use a small driver with a straight, untapered blade as shown on the right to tighten the power terminals.

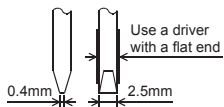

Manufacturer	Model Name
Phoenix Contact Inc.	SZS 0.4 2.5

Wiring example

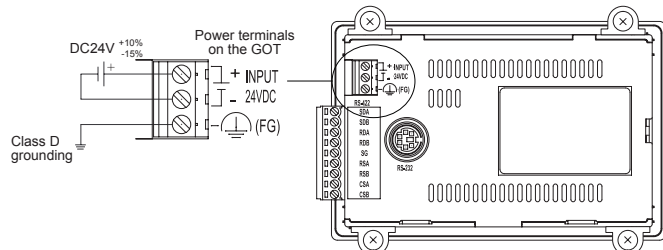

Tightening torque for the power terminals	0.5 to 0.8 N•m
---	----------------

Grounding the GOT and other devices

Make sure to carry out the followings for grounding. Except 5V power supply type.

- Carry out the independent grounding if possible. Provide class D (class 3) grounding. (Ground resistance must be 100Ω or less.)
- If the independent grounding is impossible, carry out the shared grounding as shown in fig. 2) below.

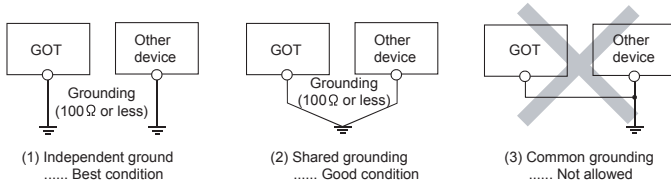

- Set the grounding point closer to the GOT to make the grounding cable short as possible. Provide grounding using a single grounding wire. Below to shows the proper size grounding wire.

Ground Wire Size		
Solid wire	Stranded wire	Ferrules with plastic sleeve
1.5mm ² , AWG16	1.0mm ² , AWG16	0.5mm ² , AWG20

THE CAUSE OF MALFUNCTIONS RELATED WIRING/REMEDY

Grounding of the GOT may cause electric potential difference and noise interference, which may result in GOT malfunctions. These problems may be resolved by taking the following measures.

- Wiring path of the GOT's ground cable and power line Bundling the GOT's ground cable and power line together can cause interference noise, which may result in malfunctions. Keeping the GOT's ground cable and power line away from each other will help minimize noise interference.

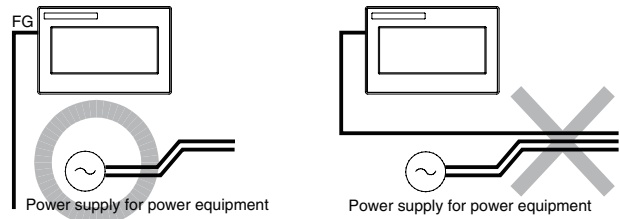

Good: Wiring the ground cable away from the power cable

Bad: Bundling the ground cable and the power cable

Connecting the ground cable from the panel that houses control equipment to the panel to which the GOT is grounded.

When running a single ground cable from the panel that houses such piece of control equipment as a sequencer to the panel to which the GOT is grounded, the ground cable may have to be directly connected to the terminal on the GOT.

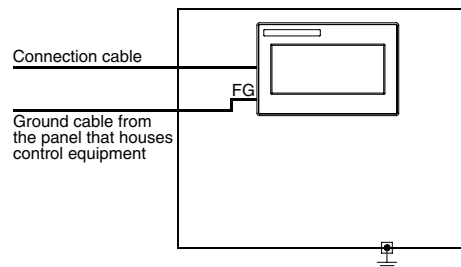

If electric potential difference between the ground points created by it causes malfunctions, lowering the voltage as shown in Remedy 1 below may solve the problem.

Remedy 1 (Refer to the figures Remedy 1-1 and 1-2 below.)

If the electric potential difference between the ground cable and the panel that houses the GOT is creating problems, connect the ground cable to the panel also. If the wiring method as shown in Remedy 1-1 is not feasible, follow Remedy 1-2.

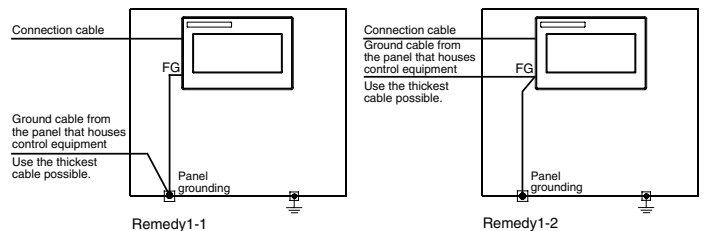

If taking Remedy 1 worsens noise interference, taking Remedy 2 may alleviate it.

Remedy 2 (Refer to the figures Remedy 2-1 and 2-2 below.)

Attach a ferrite core to the cable if noise from the GOT panel has adverse effects on the GOT when Remedy 1 is taken. Wind the wire around the ferrite core several times (approx. 3 times), if a ferrite core is used. If the wiring method as shown in Remedy 2-1 is not feasible, follow Remedy 2-2.

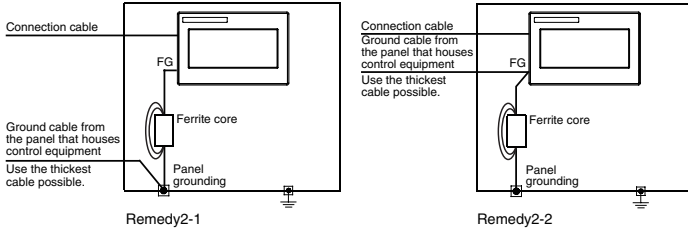

7.2 WIRING INSIDE AND OUTSIDE THE PANEL

Wiring inside

Run power lines, servo amplifier drive wires, and communication cables so that they do not cross each other. Noise interference that is generated by cables that cross each other may cause malfunctions. Surge suppressors are an effective way to filter out surge noise that is generated from no fuse breakers (NFB), electromagnetic contactors (MC), relays (RA), solenoid valves, and induction motors.

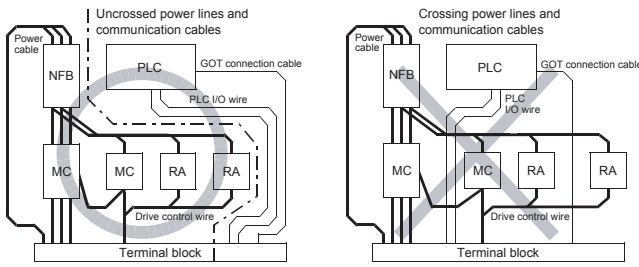

Outside the panel

To pull the power line and communication cable out of the panel, make two pullout holes away from each other and pull the cables through. Putting both cables through the same pullout hole will increase noise interference.

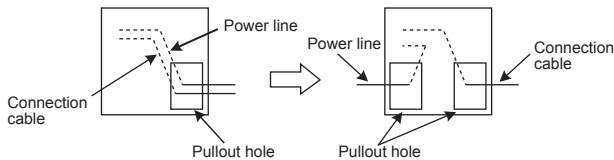

Keep the power line and communication cable inside the duct at least 100 mm away from each other. If that is not possible, the use of a metal separator inside the duct can reduce noise interference.

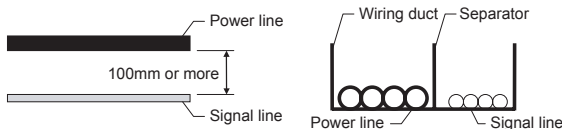

Attaching surge killers to control equipment

If communication errors happen in sync with the on/off signals from certain control equipment (referred to as "load" hereafter) such as no fuse breakers, electromagnetic contactors, relays, solenoid valves, and induction motors, surge noise interference is suspected. If this problem happens, keep the ground cable and communication cable away from the load. If that is not possible, an installation of a surge killer will help reduce noise interference. Place the surge killer as close to the load as possible.

Remedy for AC inductive load

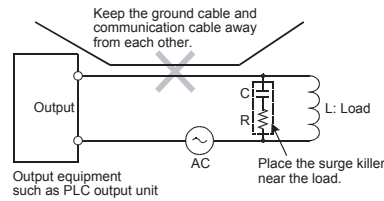

Remedy for DC inductive load

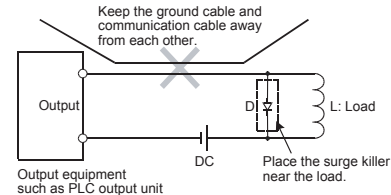

8. OPERATION SETTINGS

8.1 RS-232/USB CONVERSION ADAPTOR

GT10-RS2TUSB-5S RS-232/USB conversion adaptor is an adaptor that converts the RS-232 interface for communication with PC on the GOT to the USB interface. It is used with a GT09-C30USB-5P USB cable. The use of a GT10-RS2TUSB-5S RS-232/USB conversion adaptor requires an installation of the USB driver that is supplied with the package.

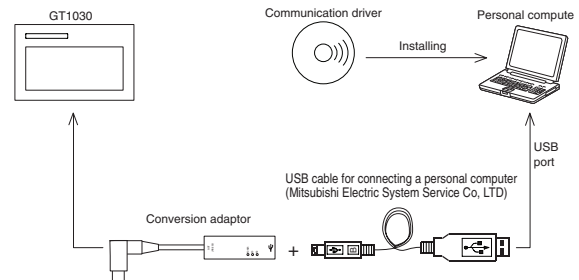

ADAPTOR COMPONENTS

The shape, dimensions, and names of the RS-232/USB conversion adaptor are shown in the figures below

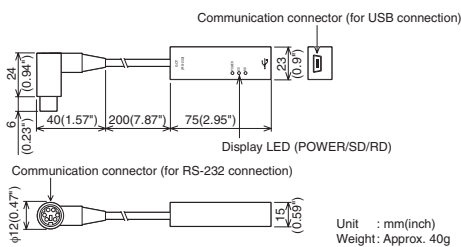

Name	Specifications
Communication Connector (for RS-232 Connection)	MINI-DIN 6 pins (male): For connection to the interface for communication with PC on the GOT
Communication Connector (for USB Connection)	USB MINI: For connection to the GT09-C30USB-5P USB cable
Display LED (POWER)	Green : Lit when the power is properly supplied (Lit when connected to the PC with a USB cable)
Display LED (SD)	Red: Lit while sending data (GOT PC)
Display LED (RD)	Red: Lit while receiving data (PC GOT)

1. Turn off the GOT power.
2. Connect the USB mini connector on the GT09-C30USB-5P USB cable to the RS-232/USB conversion adaptor.
3. Connect the RS-232 connector on the RS-232/USB conversion adaptor to the GOT.
4. Connect the USB connector on the GT09-C30USB-5P USB cable to the PC.
5. Turn on the GOT power.
6. Turn on the PC power.
7. Confirm that the POWER LED (POWER) on the RS-232/USB conversion adaptor is lit. (Lit POWER LED on the RS-232/USB conversion adaptor indicates that the power is properly supplied from the PC.)

■ DRIVER INSTALLATION

Procedure for installing the driver is explained below.

Windows® XP installation follows.

- Windows® 98, Windows® 98SE, Windows® Millennium Edition, Windows® 2000, Windows® XP, Windows® Vista and Windows® 7/8 the installation method will vary. Installation of the driver is canceled during the following process, the installation is not carried out correctly. If the installation is canceled, uninstall the driver and install again. Please refer to page 15 for instructions on uninstalling the driver.

Folder structure of USB driver software

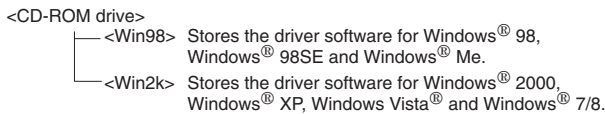

Windows® 98, Windows® 98SE, Windows® Millennium Edition, Windows® 2000, and Windows® XP

Installation method of driver software

1. Two types of drivers are required to be installed. Make sure to install the two types of drivers by the following procedure.
2. When the included CD-ROM is not used For GT Designer2 Version2.109P or later and GT Designer3 Version1.17T or later, the driver software is stored in the following folder.

[MELSOFT\GT10USBDrivers]

By specifying the above folder, the drivers can be installed.

1. When the USB cable is connected to the personal computer, the screen below is displayed.

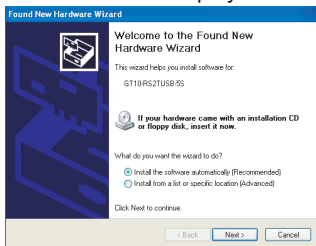

(Installation of the software for USB driver) Insert the included CD-ROM into the personal computer's CD-ROM drive. Click [Next >].

The installation of the USB driver software will begin. The installation location selection screen is displayed.

- In Windows® 98, Windows® 98SE or Windows® Millennium Edition, check [Include this location in the search], specify the CD-ROM

drive [Win98], and then install the driver software.

- In Windows® 2000 or Windows® XP, check [Include this location in the search], specify the CDROM drive [\\Win2K], and then install the driver software.
2. The screen below is displayed. (Only in Windows® XP) Click [Continue Anyway].

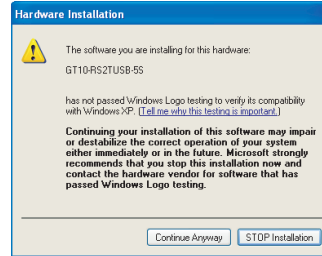

3. The screen below is displayed. Click [Finish]. The installation of the USB driver software will finish.

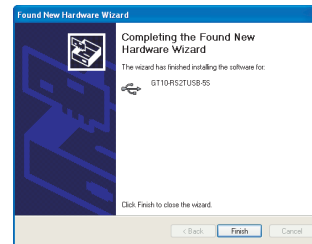

- If Windows® 98, Windows® 98SE or Windows® Millennium Edition is used, installation of the USB Serial Port software begins, and ends automatically.

The CD-ROM can be removed from the personal computer at this time. The installation of the USB driver software is finished. If using Windows® 2000 or Windows® XP, proceed to step

4. The screen below is displayed. Click [Next >]. The installation of the USB Serial Port software will begin. In Windows® 2000, check [Include this location in the search], specify the CD-ROM drive [\\Win2K], and then install the driver software.

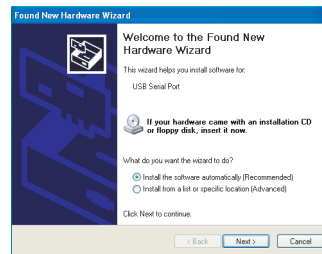

5. The screen of No. 2 is displayed. (Only in Windows® XP) Click [Continue Anyway].

6. The screen on the left is displayed. Click [Finish]. The installation of the USB Serial Port software will finish. The CD-ROM (USB driver software) can be removed from the personal computer at this time.

Windows® Vista

Installation method of driver software

1. Two types of drivers are required to be installed. Make sure to install the two types of drivers by the following procedure.
2. When the included CD-ROM is not used For GT Designer2 Version2.109P or later and GT Designer3 Version 1.17T or later, the driver software is stored in the following folder.

[MELSOFT\GT10USBDrivers]

By specifying the above folder, the drivers can be installed.

3. Insert the CD-ROM offered as an accessory in step No. 3. Do not insert it earlier.

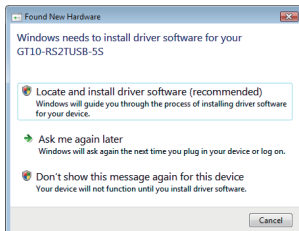

1. When the USB cable is connected to the personal computer, the screen on the left is displayed. (Installation of the software for USB driver) Click [Locate and install software (recommended)].
2. The search method confirmation screen is displayed. Click [Don't search online].
3. When the message [Insert the disc that came with your GT10-RS2USB-5S] is displayed, insert the CDROM into the personal computer. Inserting the CD-ROM starts installation. When specifying the search location manually, specify the CD-ROM drive [Win2K].
4. The warning message on the left is displayed. Click [Install this driver software anyway].

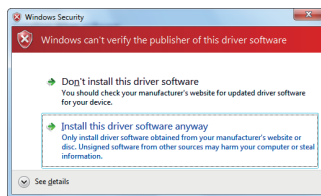

5. Installation of the driver software is started.
6. When installation of the USB driver software is finished, the COM port driver software is installed continuously. The screen on the left is displayed. Click [Don't search online].

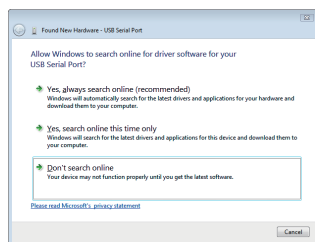

7. When the message [Insert the disc that came with your USB Serial port] is displayed, insert the CDROM into the personal computer. Inserting the CD-ROM starts installation. When specifying the search location manually, specify the CD-ROM drive [Win2K].
8. The warning message on the left is displayed. Click [Install this driver software anyway].

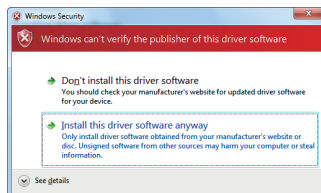

9. Installation of the driver software is started.
10. When installation is finished, remove the CD-ROM. Now, installation of the USB driver software is finished.

Windows® 7/8 (32bits)

Installation method of driver software

1. Two types of drivers are required to be installed. Make sure to install the two types of drivers by the following procedure.
2. When the included CD-ROM is not used
For GT Designer2 Version2.109P or later and GT Designer3 Version 1.17T or later, the driver software is stored in the following folder.
[MELSOFT\GT10USBDrivers]
By specifying the above folder, the drivers can be installed.
3. Insert the CD-ROM offered as an accessory in the step No. 4. Do not insert it earlier. The screen displays in the following instruction are display examples in Windows® 7. In Windows®8, use the GT10USBDrivers ver.1.30 or later.

1. Connect the USB cable to the personal computer.
2. Click [Control Panel] → [Hardware and Sound] → [Device Manager] to display the screen below. Right-click the GT10-RS2TUSB-5S, and select [Update Driver Software].

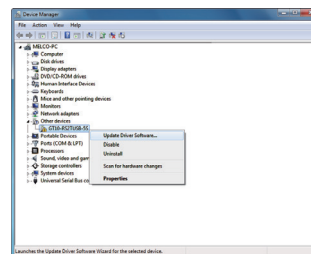

3. When the driver software search method selection screen is displayed, select [Browse my computer for driver software].
4. Insert the CD-ROM into the personal computer.
5. The search location specification screen is displayed. Specify the CD-ROM drive [Win2K] as the search location, and click [Next]. Installation is started.
6. A warning message is displayed. Select [Insert this driver software anyway].
7. Installation of the driver software is started.
8. When installation of the USB driver software is finished, the COM port driver software is installed continuously. Right-click [USB Serial Port] in the Device Manager. Select [Update Driver Software].

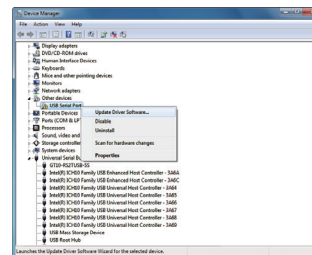

9. When the driver software search method selection screen is displayed, select [Browse my computer for driver software].
10. The search location specification screen is displayed. Specify the CD-ROM drive [Win2K] as the search location, and click [Next]. Installation is started.
11. A warning message is displayed. Select [Install this driver software anyway].
12. Installation of the driver software is started.
13. When installation is finished, remove the CD-ROM. Now, installation of the USB driver software is finished.

Windows® 7/8 (64bits)

Installation method of driver software

- Two types of drivers are required to be installed. Make sure to install the two types of drivers by the following procedure.
- When the included CD-ROM is not used
For GT Designer3 Version1.31H or later, the driver software is stored in the following folder.
[MELSOFT\GT10USBDrivers]
By specifying the above folder, the drivers can be installed.
- Insert the CD-ROM offered as an accessory in the step No. 6. Do not insert it earlier. The screen displays in the following instruction are display examples in Windows® 7. In Windows® 8, use the GT10USBDrivers ver.1.30 or later.

- Connect the USB cable to the personal computer.
- Select [Control Panel] → [Hardware and Sound] → [Devices and Printers] to display the screen on the left. Right-click the GT10-RS2TUSB-5S, and select [Properties].

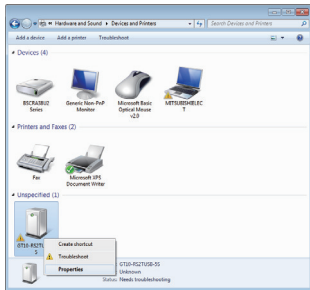

- The screen below is displayed. Select [Properties] of the [Hardware] tab.

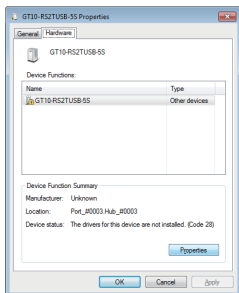

- The screen on the left is displayed. Select [Change settings] → [Update Driver].

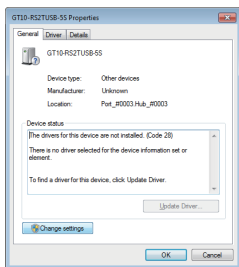

- When the driver software search method selection screen is displayed, select [Browse my computer for driver software].
- When installing the drivers from the included CD-ROM, set the CD-ROM in a personal computer.
- The search location specification screen is displayed.

- Installing from the CD-ROM
Specify the CD-ROM drive [Win2K] as the search location, and click [Next].
 - Installing from the drawing software
Specify [MELSOFT\GT10USBDrivers] in the folder where GT Designer3 is installed and click [Next]. Installation is started.
- A warning message is displayed. Select [Insert this driver software anyway].
 - Installation of the driver software is started.
 - When installation of the USB driver software is finished, the COM port driver software is installed continuously. Select [Control Panel] → [Hardware and Sound] → [Devices and Printers] to display the screen on the left. Right-click the GT10-RS2TUSB-5S, and select [Properties].

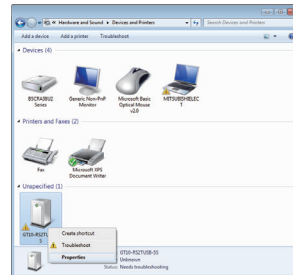

- The screen on the left is displayed. Select [USB Serial Port] → [Properties] of the [Hardware] tab.

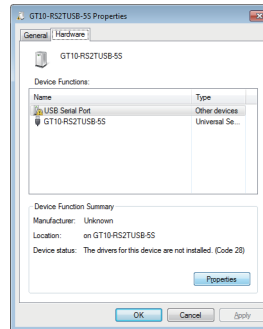

- The screen on the left is displayed. Select [Change settings] → [Update Driver].

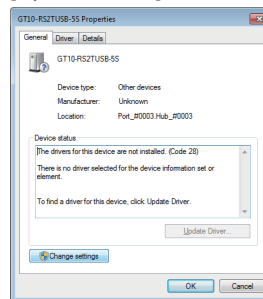

- When the driver software search method selection screen is displayed, select [Browse my computer for driver software].
- The search location specification screen is displayed.
 - Installing from the CD-ROM
Specify the CD-ROM drive [Win2K] as the search location, and click [Next].
 - Installing from the drawing software
Specify [MELSOFT\GT10USBDrivers] in the folder where GT Designer3 is installed and click [Next]. Installation is started.

15. A warning message is displayed. Select [Install this driver software anyway].
16. Installation of the driver software is started.
17. When installation is finished, remove the CD-ROM. Now, installation of the USB driver software is finished.

■ METHOD FOR UNINSTALLING DRIVER

The procedure for uninstalling the driver is explained below.

A Windows® XP example follows.

When the driver softwares for FX-USB-AW/FX3U-USB-BD and GT10-RS2TUSB-5S are installed, uninstalling one of these driver softwares may cause the other not to function properly. When this happens, reinstall the driver software.

1. Detach the USB cable from the personal computer.
Click [Start] → [Control Panel] → [Add or Remove Programs] in the menu of the personal computer, the window below will be displayed.
 - In case of Windows® 98, Windows® 98SE, Windows® Millennium Edition, and Windows® 2000. A screen that is equivalent to the one below is displayed by clicking [My Computer] → [Control Panel] → [Add/Remove Programs] in the menu of the personal computer.
 - In Windows® Vista click [Start] → [Control Panel] → [Hardware and Sound] → [Device Manager] and the window below will be displayed.
 - In Windows® 7, click [Control Panel] → [Hardware and Sound] → [Device Manager] and the window below will be displayed.

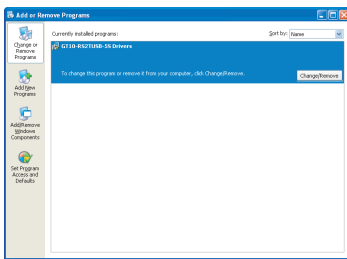

Click [Change/Remove].

2. The screen below is displayed. Click [Continue]. Then the bottom screen is displayed. Click [Finish].

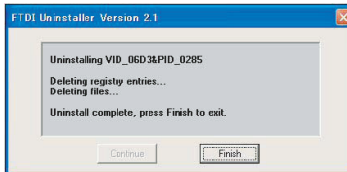

8.2 BATTERY

The battery backs up clock data, alarm history and recipe data. At factory shipment, a battery is built in the GT1030.

Applicable battery

Model Name	Description
GT11-50BAT	Battery for backup of clock data, alarm history, recipe data and time action setting value

Battery specifications

Item	Description
Type	Magnesium manganese dioxide lithium primary battery
Initial Voltage	3.0V
Storage Life	Approx. 5 years (Operating ambient temperature of 25°C)
Application	For backup of clock data, alarm history, recipe data and time action setting value

Replace battery periodically at intervals of 4 to 5 years as reference.

1. Turn the GOT power off.
2. Open the back cover of the GOT.
3. Remove the old battery from the holder.

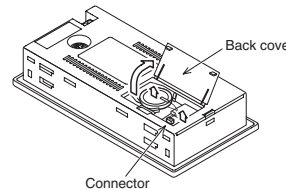

4. Disconnect the old battery connector and insert the new battery connector within 30s.
5. Insert the new battery into the holder and close the back cover.
6. Turn the GOT power on.
7. Check if the battery condition is normal with the utility.

8.3 UTILITY FUNCTION

The utility functions allow the user to confirm the settings for communication interface, screen display, operation methods, and clock data as well as OS information. GT10 is factory-installed with the Standard monitor OS and BootOS. (An installation of the Standard monitor OS or BootOS is not required to use the utility functions.)

Utility Function List

The items in the following list can be set/operated on the utility screens.

Item	GT1030	
Language	Switches the display language for the utility functions (Japanese/English)	
Standard I/F	Displays the detailed information about the communication method and communication driver	
Data Transfer	Displays the screen for transferring project data between the PC and GOT (If any device other than the PC is allocated to the interface for communication with PC, the GOT will not be able to communicate with the PC, except when the Data transfer window is on the screen.)	
Communication Monitor	Displays the communication status of each communication port	
Keyword	Sets a keyword of the FX series PLC.	
Screen Save	Time	Sets the screensaver activation time (from the last time the screen was touched) Setting range: 0 to 60 min. (Screensaver is disabled when it is set to 0 minute.) Default: 0 min.
	Backlight	This setting is used to decide whether to turn the backlight on or off when the screensaver comes on Default: OFF
Contrast	Adjusts the contrast on the liquid crystal display (16 level adjustment, 0 to 15)	
Brightness	Adjusts the intensity on the liquid crystal display (8 level adjustment, 0 to 7)	
Opening Time	The title display period at the main unit boot can be set. (0 to 60 sec) Default: 5 sec	
Buzzer Setting	Buzzer Volume	Changes the buzzer settings (OFF/SHORT/LONG) Default: SHORT
	Window Move Buzzer	Whether turn ON/OFF buzzer when move window can be selected Default: ON
Calibration	-	

Security *1	Security level change (security password input of each object)	
Utility Call	Setting of the menu call key	
Key Reaction	Display of key reaction speed	
Clock Setting	Setup the method to adjust the time between GOT clock data and clock data of PLC CPU connected with GOT	
Time Setting	Sets the clock (clock data) on the PLC, Display of battery status	
Data	OS Information	Displays the OS (Standard monitor OS, BootOS) and communication driver versions
	Clear Data	Clears the project data and resource data on the GOT
	GT10-50FMB	-
Debug	Device Monitor	Device monitor of PLC of intelligent module
	FX List Editor	-
	FX3U-ENETADP Communication Setting Function	The communication set value of the FX3U-ENET-ADP stored in the CPU can be changed.
Clean	Display the screen to clean the display section	

*1: It is necessary to set the security level with drawing software.

8.4 UTILITY DISPLAY

Display operation of main menu

The following four types of operation can display the main menu. (The utility function windows appear in the horizontal format, and this format cannot be changed.)

When project data is not downloaded

After the GOT is turned on, a dialog box for notifying of absence of project data is displayed. After the dialog box is displayed, touch the [OK] button to display the main menu.

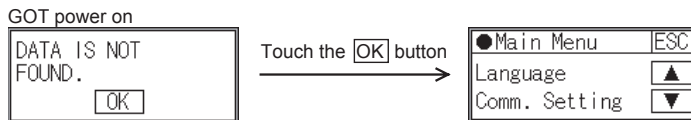

When touching menu call key

If you touch the menu call key while a user-created screen is displayed, the main menu is displayed. The menu call key can be set with the GOT utility screen or drawing software. (At factory shipment, menu call key is set to "Simultaneous 2 - point presses on GOT screen upper - right and upper - left corners" on the GT1030.)

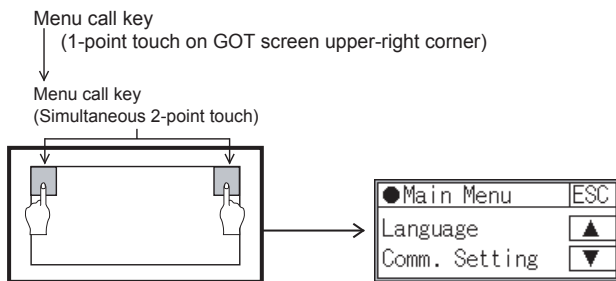

When the utility call key is set to the zero point

Even when the utility call key is set to the zero point, you can display the main menu using either of the following two operations:

- Pressing the special function switch set on the user-created screen
- Selecting [Utility] from the "Select mode" screen

When touching special function switch

If you touch the special function switch (utility) while user-created screen is displayed, the main menu is displayed. The special function switch (utility) can be set as a touch switch that is displayed on a user-created screen by drawing software. (When the utilities menu is

assigned to the special function switch, the main menu appears when the switch is touched.)



When selecting the start mode

The "Select mode" screen appears when you power ON the GOT while touching the upper left corner of the screen. If you touch [Utility] on the "Select mode" screen, the main menu is displayed.

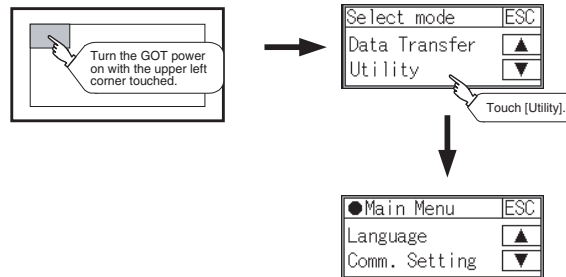

Lock the utility display by password

When a password is set on the GOT using drawing software, a password dialog box is displayed when trying to access the main menu of the utility display. (The password setting option in drawing software is located in the common menu.) Enter the password that has been set.

Input operation of password

1. Input the password after touching [0] to [9], [A] to [F] key.
2. Define the password by touching [ENTER] key, after inputting password.
3. To correct the input character, touch [DEL] key to delete the correcting character and then reinput/retype the new character.

Password input cancel operation

1. When [ESC] button is touched, the screen returns to the monitor screen.

If an invalid password is entered

If an invalid password is entered, the error message will appear. Touching the [OK] button will take the screen back to the monitor screen.

When starting the GOT without selecting any language (At factory shipment) The following screen will be displayed at the initial startup of GOT. Touching the button of a desired language restarts the GOT and the language is switched to the selected one.

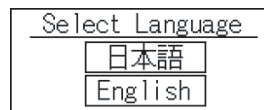

The menu items that can be selected from the GOT utility are displayed

1. Use the [▲], [▼] buttons to select an item from the menu.
2. Touching a menu item in the main menu will display the setting screen or following selection screen for the item.
3. Touching the [ESC] button will take the screen back to the user screen.

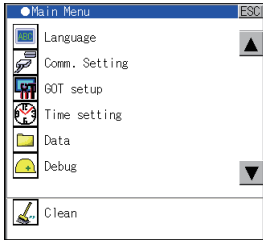

Title display

The screen title name is displayed in title display part.

Close/Return button

When a middle screen of the layers is displayed, if the [ESC] (Close/return) button in the right corner of screen is touched, returns to the previous screen. If this button is touched when directly displayed from monitor screen, the screen is closed and returns to monitor screen.

Scroll button

For screens in which the content does not fit on one screen page, there is a right or down scroll button on the screen. [▲], [▼] Scroll one line/window

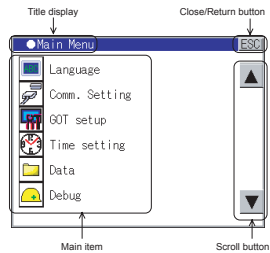

STANDARD I/F DISPLAY OPERATION

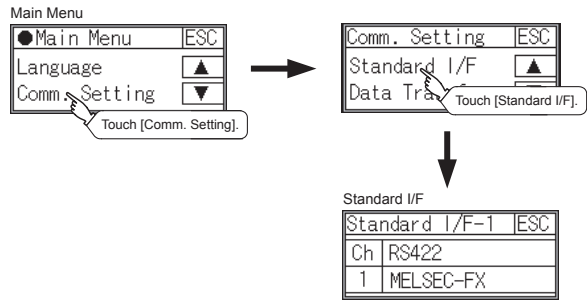

Described below are the display items on the standard I/F setting menu and their functions.

1. Display item column

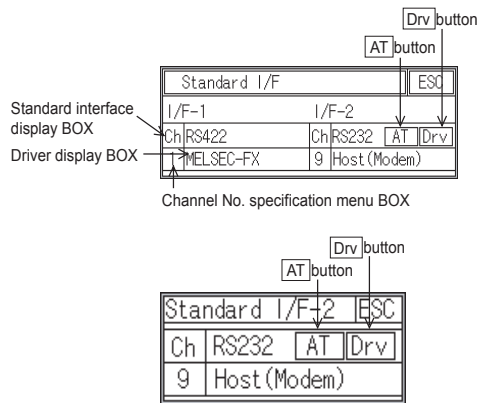

8.5 COMMUNICATION INTERFACE SETTING

The [Communication Setting] menu has the [Standard I/F], [Data Transfer], [Communication Monitor], and [Keyword] menus. The [Standard I/F] menu sets the information about the channel numbers, controller name, and detailed settings of the communication parameters that are allocated to the communication interfaces by drawing software.

The [Data Transfer] menu displays the screen for transferring project data between the PC and GOT. The [Communication Monitor] menu displays the communication status of each communication port. The [Keyword] menu registers, deletes, clears, and protects a keyword of the FX series PLC.

Standard I/F functions

Function	Contents
Channel no. display	Displays the channel number (CH No) that has been assigned by drawing software
Communication driver display	Displays the communication driver that has been assigned by drawing software
Communication parameters display	Displays the communication parameters of the controllers that has been assigned by drawing software

Standard interface display BOX

Displays communication interface.

The standard interface includes the following two types.

- Standard I/F-1: For communication with PLC, microcomputer and other equipment
- Standard I/F-2: For communication with PC (drawing software), modem, bar code reader and transparent

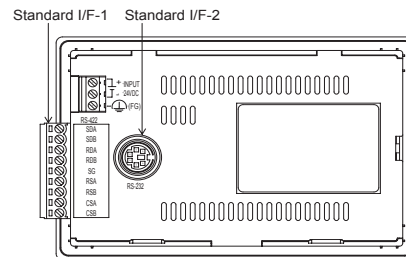

Whether an RS-422 or an RS-232 interface (Standard I/F-1) for communication with PLC is used depends on the GOT model.

- GT1030-HBD: RS-422 fixed

Channel No. specification menu BOX

0: Set when the communication interface is not used.

1: Set when connecting to PLC or microcomputer.

(For GT1030, settable only for the interface (Standard I/F-1) for communication with PLC)

- ▶ Set when connecting to bar code reader.
- ▶ Set when connecting to PC (drawing software), modem. (For standard I/F-2 and standard I/F-3, the simultaneous setting is possible. However, when either interface is communicating, the communication is not allowed for another interface.)

- Setting is not allowed for 2 to 7, *.
- Fixed to 9 for the USB interface.

Driver display BOX

The name of the communication driver for which a channel number is assigned is displayed. "None" is displayed in the driver display box in the following cases :

- ▶ The communication driver is not installed.
- ▶ "0" is set in the channel number specification menu box.
- [****] will appear when the communication driver that was installed on the GOT from drawing software and the controller setting that was downloaded on to the GOT from drawing software do not match.
- When setting the channel number to "9", the communication driver "Host (PC)" is automatically assigned.
- When the driver display box is touched, the screen jumps to the detail information screen and the communication parameter appears.
- [DRV] button
Displays the driver setting screen.
Select the driver to use on the driver setting screen.
- [DRV] button is displayed in the following cases.
When setting the "ch9" to standard I/F-2.
- [AT] button
Displays the AT command setting screen.
Set the AT command to use for initializing the modem on the AT command setting screen.
- [AT] button is displayed in the following case.
When "ch9 Host (Modem)" is set to standard I/F-2.

■ DETAIL INFORMATION SETTING OPERATION

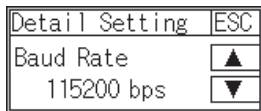
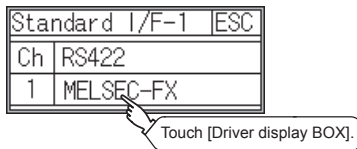

1. Touch Standard I/F-1 driver display box in the Standard I/F setting window.
2. The screen jumps to the detailed information screen and the communication parameter will appear. Use the [▲], [▼] buttons to toggle through the items when there are multiple items to be set. (The [▲], [▼] buttons will not work when no other items are available.)
3. Touch the numerical values of baud rate to switch them repeatedly.

Ex. 4800bps → 9600bps → 19200bps

The numerical values are set using the ten-key depending on the setting

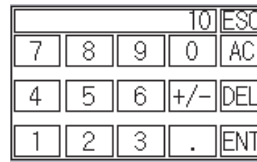

- ▶ "0" to "9": Use these keys to enter numerical values. Enter "0" to disable the screensaver function
- ▶ "ESC" : Closes the ten-key window without saving any value entered
- ▶ "AC" : Deletes the entire string of numerical characters that are being entered
- ▶ "DEL" : Deletes a digit from a string of numerical characters that are being entered
- ▶ "ENT" : Enters the value for the clock that has been entered and closes the ten-key pad window
- ▶ "+ / -" : Switches between positive and negative values (Only positive values are valid for the clock setting.)
- ▶ "." : Invalid key (not used)

When the [ESC] button is touched, the settings are fixed and the window returns to the previous one. Therefore, touch the [ESC] button.



Touch the [ESC] button to display the window confirming whether to save the settings.

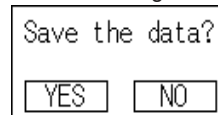

Touch the [YES] button to save the settings and restart. Touch the [NO] button to discard the changes.

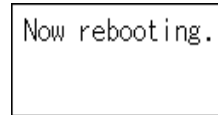

The types of items that are in the communication parameter setting menu depend on the type of communication driver that is installed on the GOT in use. Refer to the section below for the setting contents of various drivers.

Precautions for communication between GOT and connected devices

1. Installing [Communication driver] and downloading [Communication Settings] To perform communication with the connected device, the following actions are necessary.
 - a. Installing [Communication driver] (Up to 1, OS installation)
The driver for [MELSEC-FX] is factory-installed. Install the communication driver to connect a controller other than a MELSEC-FX.
 - b. Assigning channel number and communication driver to communication interface (Communication Setting)
 - c. Downloading [Communication Settings] (project data) assigned in step 2)

Perform a), b) and c) with drawing software.

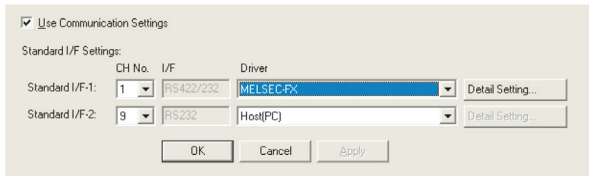

- To change the communication parameter setting after downloading project data, change the setting at drawing software again.
 - When [Communication Settings] has not been downloaded using drawing software
2. When [Communication Settings] has not been downloaded, the GOT automatically assigns the installed communication driver as the standard I/F-1.

■ CHANNEL NUMBER SETTING OPERATION

1. Touch the channel No. specification menu box to be set.

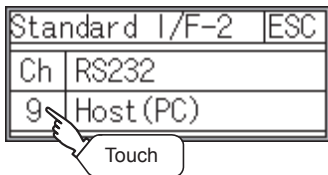

2. When the channel setting window appears, select the channel number.

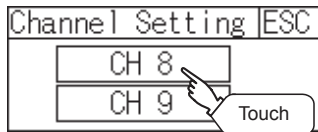

3. When the channel number is selected, the settings are fixed and the window returns to the previous one. Therefore, touch the [ESC] button.

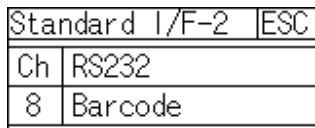

4. Touch the [ESC] button to display the window confirming whether to save the settings.

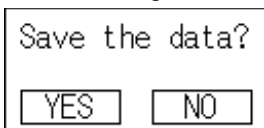

5. Touch the [YES] button to save the settings and restart. Touch the [NO] button to discard the changes.

NOTE: Only channel number 1 is displayed on the standard I/F-1 of the GT1030.

■ DRIVER SETTING OPERATION

1. Touch [Drv] button to bring up the driver setting window.



2. The available driver names are displayed on the driver setting screen. Select the driver to use.

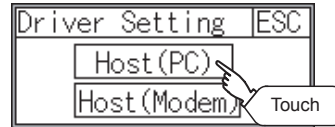

3. When the driver is selected, the display returns to the standard IF setting screen. Touch [ESC] button.

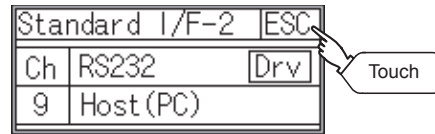

■ AT COMMAND OPERATION

1. Touch [AT] button to bring up the AT command setting window.

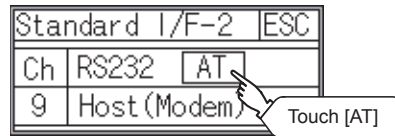

2. The AT command, set in the drawing software or in the utility of the main unit, is displayed. When editing the AT command, touch [SET] button to display the ASCII window. Input the AT command in the ASCII window.



3. Touch following buttons as necessary.

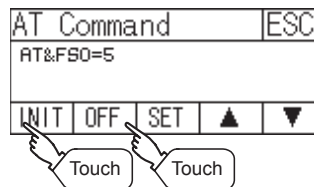

- ▶ [INIT] button: Outputs the AT command to the modem.
- ▶ [OFF] button: Disconnects the line.

4. After settings are completed, touch [ESC] button to close the setting screen.

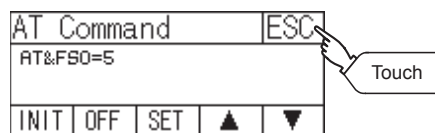

■ INSTALLING OF COMMUNICATION DRIVER

GT10 is factory-installed with the driver for MELSEC-FX. An installation of the communication driver is required when connected to a controller other than a MELSEC-FX. When installing the communication driver, first bring up the OS installation screen on the GOT, and then install the communication driver from drawing software.

Bringing up the OS installation screen

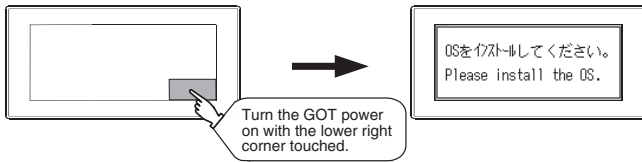

About the OS installation screen

The OS can be transferred from GT Designer2 or GT Designer3 without displaying the OS installation screen depending on the combination of the GOT and the standard monitor OS.

Model	BootOS Version	Standard Monitor OS	GT Designer2	GT Designer3
GT1030	BootOS version F or later	Standard monitor OS [01.08.00] or later	Version2.77F or later	From the first version

Checking method of BootOS, Standard monitor OS version

1. Check the version of BootOS or Standard monitor OS installed in GOT at [OS information] of the utility.

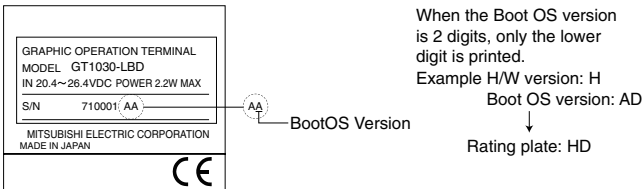

2. Check the version of BootOS installed in GOT at product shipment on the rating plate on GOT rear face.

8.6 DATA TRANSFER

Function	Contents
Data Transfer Screen Display	Displays the screen for transferring project data between the PC and GOT. If any device other than the PC is allocated to the interface for communication with PC, the GOT will not be able to communicate with the PC, except when the Data transfer window is on the screen.

Display from the utility main menu

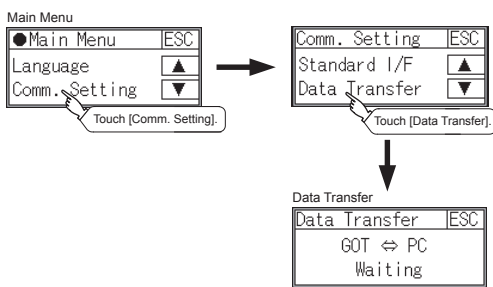

Display from the select mode

If data transfer screen cannot be displayed on the user-created screen, power ON to perform select mode while pressing and holding the upper left corner of the screen. The selection screen of [Normal] or [Data Transfer] appears at the startup. In the [Normal], an initial screen appears when the monitor screen has been created, and the utility main menu appears when the monitor screen has not been created. [Data Transfer] screen appears in the [Data Transfer]. Standard I/F-2 is used in the communication mode to the PC.

Bringing up the select mode screen

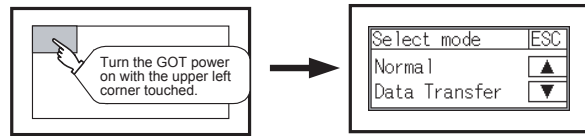

DATA TRANSFER DISPLAY

[Waiting] on the data transfer screen will change to [Transferring...] when project data are transferred from drawing software. At the completion of data transfer, the user-created screen will appear.

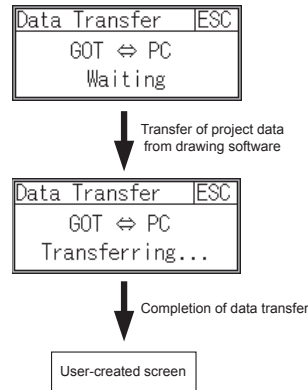

Transfer of project data

If [ESC] button on the display screen is pushed during transfer of project data, transmission of project data is stopped. In that case, project data are transferred from drawing software again.

8.7 COMMUNICATION MONITOR

Function	Contents
Communication port-selection status display	Displays the connection status of Standard I/F-1 and I/F-2
Communication status display	Displays the communication status (SD: send, RD: receive)
Communication error status display	Displays an error message when a communication error occurs

Communication Monitor display operation

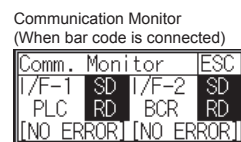
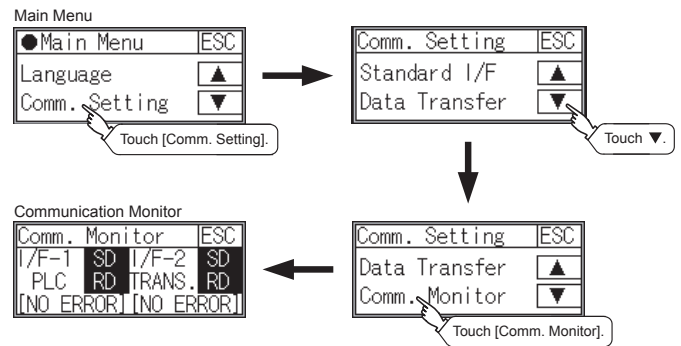

Screen display content

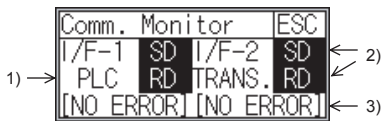

Connection status of the communication ports

Indicates the connection status of Standard I/F-1 and I/F-2. Listed in the table below are display items and the connection status (channel number).

Display Item	Channel Number	Remarks
PLC	Ch1	"PLC" appears when connected to a controller (PLC or microcomputer)
BCR	Ch8	"BCR" appears when connected to a bar code reader
TRANS.	Ch9	"TRANS." appears when the controller that is allocated to one of the communication ports supports the transparent mode "TRANS." automatically changes to "PC" when communicating with drawing software
PC	Ch9	"PC" appears when the controller that is allocated to one of the communication ports does not support the transparent mode

Communication status

Communication status of each communication port is displayed on this screen. The [SD] and [RD] symbols appear in black on white while data are being sent or received, and in white on black at other times. They may appear lit depending on the communication status.

The SD and RD symbols on the screen indicate normal communication or cable disconnection.

Port	Channel Number	Controller Type
I/F-1	Ch1	MELSEC-FX
I/F-2	Ch8, Ch9	-

[During normal communication (with connection to a device that supports the transparent mode)]

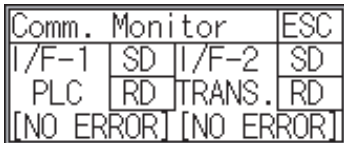

The SD and RD symbols for both I/F-1 and I/F-2 blink.

[When the connecting cable with the controller is disconnected]

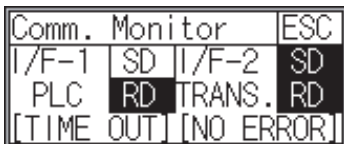

Only the SD symbol next to I/F-1 blinks.

Communication error status

Communication error status of each port is displayed on this screen. The table below summarizes the types and nature of the errors.

Display Item	Action
NO ERROR	Communication is executed normally.
ERR Ovr.	The receive data is sent continuously with a short interval. Let the baud rate (communication speed) be equivalent between the GOT and counterpart equipment.
ERR Frm.	The communication frames of GOT and PLC are inconsistent. Confirm the communication settings of GOT and PLC, such as data length, stop bit and baud rate.
ERR Prt.	The parity check conditions of GOT and PLC are inconsistent. Let the parity check condition (odd or even) of GOT and PLC be consistent.
ERR Text	The sum data is inconsistent. Or the contents of the receive data are not consistent with the send command from the GOT. Let the communication settings and contents of data be consistent between the GOT and counterpart equipment. (If NAK is received while the GOT is connected to the microcomputer board, a text error occurs.)
TIME OUT	Though receiving is started, receive data is not sent. Check the wiring between the GOT and its communication target. (When the GOT is connected to the microcomputer board, confirm the terminator, CR, wiring, etc.)
ERR Line	The control line is not operating correctly. Confirm the wiring of the control line.
ERR Cmd.	A command contained in the receive data is not consistent with the send command from the GOT.

8.8 DISPLAY SETTINGS

Setting regarding display is possible. The items which can be set are shown below.

Items	GT1030	Setting Range
Screen Save Time	The period from the user stops the touch panel operation till the screen save function starts can be set.	0 to 60 minutes <At factory shipment: 0 minutes> When set to 0, the function becomes invalid.
Screen Save Backlight	Whether turn ON or OFF the backlight simultaneously at the screen save function start can be specified.	ON/OFF <At factory shipment: OFF>
Brightness	The brightness can be adjusted.	8-level adjustment (0 to 7)
Contrast	Contrast can be adjusted.	16-level adjustment (0 to 15) <At factory shipment: 10>
Opening Time	The title display period at the main unit boot can be set.	0 to 60 seconds <At factory shipment: 5 seconds >

1. Display setting by drawing software

Set title display period, opening time, screen save time and screen save backlight at [GOT set up] in [System Environment] of GT Designer2. When using GT Designer3, execute the settings at [GOT Setup...] in [GOT Environmental Setting] of [Common]. When change a part of the setting after downloading the project data, change the setting by [Display] screen of the GOT.

2. Screen save and screen save backlight OFF function

When using the screen save and screen save backlight OFF function, select valid/invalid by the system information reading device in [System Environment] of GT Designer2. When using GT Designer3, select valid/invalid by the reading device of [System Information...] in [GOT Environmental Setting]

■ DISPLAY OPERATION OF DISPLAY SETTING

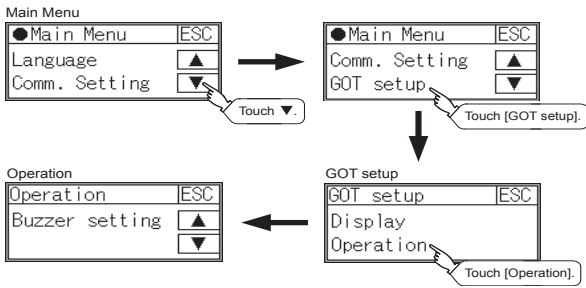

■ SCREEN SAVE TIME

1. Touch [Screen Save] to bring up the screensaver setting window.

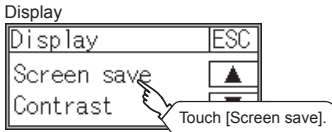

2. Touch [Time] to bring up the time setting window.

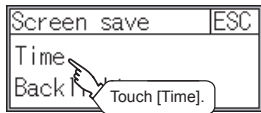

3. Touch the time that appears on the time setting window to bring up the ten-key pad.

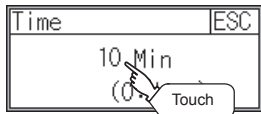

4. Enter the time using the ten-key pad.

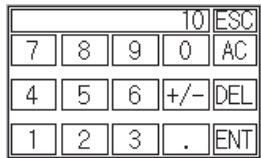

- ▶ "0" to "9": Use these keys to enter numerical values. Enter "0" to disable the screensaver function
- ▶ "ESC" : Closes the ten-key window without saving any value entered
- ▶ "AC" : Deletes the entire string of numerical characters that are being entered
- ▶ "DEL" : Deletes a digit from a string of numerical characters that are being entered
- ▶ "ENT" : Enters the value for the clock that has been entered and closes the ten-key pad window
- ▶ "+ / -" : Switches between positive and negative values (Only positive values are valid for the clock setting.)
- ▶ ". ." : Invalid key (not used)

When all the settings have been made, touch the [ESC] button to close the setting window.

■ SCREEN SAVE BACKLIGHT

1. Touch [Screen Save] to bring up the screensaver setting window.

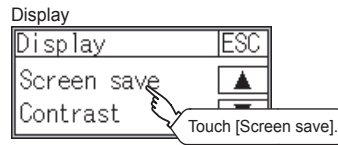

2. Touch [Backlight] to bring up the backlight setting window.

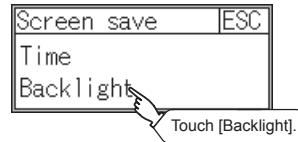

3. Touch the [OFF]/[ON] button to turn off/turn on the backlight.

- ▶ [OFF] button: Screen save, Transferring..., Backlight, Unlit
- ▶ [ON] button: Screen save, Transferring..., Backlight, Lit

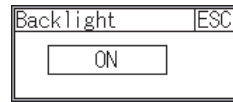
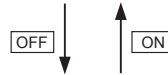
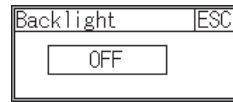

4. After changing the settings, touch the button to save the [ESC] changes and close the setting window.

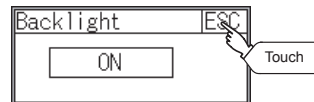

■ CONTRAST

1. Touch [Contrast] to bring up the setting window.

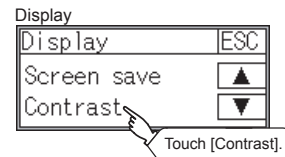

2. Touch the [+], [-] buttons to adjust the contrast of the screen.

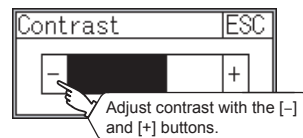

3. After changing the settings, touch the [ESC] button to save the changes and close the setting window.



■ BRIGHTNESS

1. Touch [Bright/Contrast] to bring up the setting window.

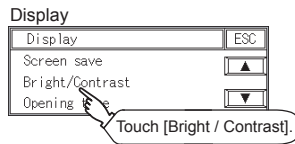

2. Touch the [-] and [+] buttons to adjust the brightness of the screen.

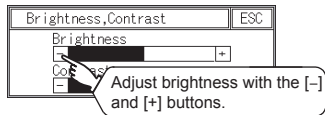

3. After changing the settings, touch the [ESC] button to save the changes and close the setting window.

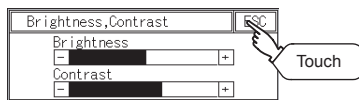

■ OPENING TIME

1. Touch [▼] to bring up the [Opening time] setting window.

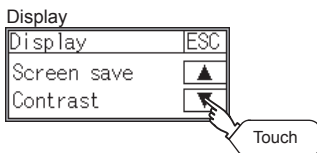

2. Touch [Opening time] to bring up the setting window.

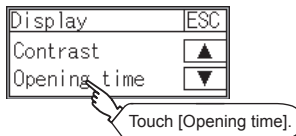

3. Touching the set time (value) can change the setting.

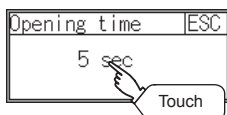

4. After changing the settings, touch the [ESC] button to save the changes and close the setting window.

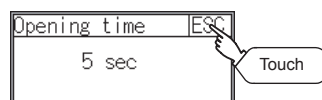

8.9 OPERATION SETTING

Function	Description	Setting Range
Buzzer Volume	Buzzer volume setting can be changed.	OFF/SHORT/ LONG (At factory shipment: SHORT)
Window Move buzzer Volume Setting	Whether turn ON/OFF buzzer when move window can be selected.	ON/OFF (At factory shipment: ON)
Key Reaction	The sensitivity of touch panel when GOT screen is touched can be set	±0 to +120 *1
Touch Panel Calibration	Touch panel reading error can be corrected.	-
Clock Setting	Set the method to adjust the time between the GOT clock data and clock data of the connected controller.	None, Adjust, Broadcast, Both <At factory shipment: Adjust>
Security	Security level screen can be displayed	-
Utility Call	Utility call key setting screen can be displayed	-

1. The more the value set for [Key reaction] is high, the more the key reaction speed slows.

Key reaction speed (ms)	±0 ms (Standard)	+10ms	+20ms	+40ms	+80ms	+120ms
-------------------------	------------------	-------	-------	-------	-------	--------

For example, when the GOT recognizes touching the GOT screen once as touching the screen twice, set a higher value for [Key reaction].

NOTE

Operation settings by drawing software
 Set buzzer volume and window move buzzer volume by [GOT setup] in [System Environment] of GT Designer2. When using GT Designer3, execute the settings at [GOT Setup...] of [GOT Environmental Setting]. When change a part of the setting, change the setting by the GOT display setting after downloading the project data.

■ DISPLAY OPERATION OF OPERATION SETTING

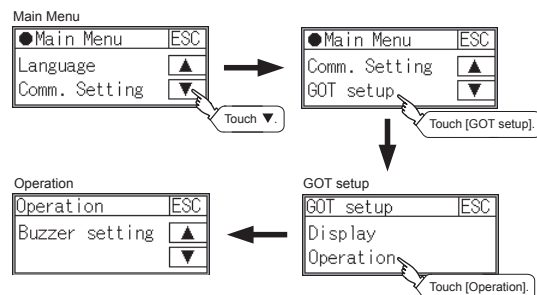

■ BUZZER VOLUME

1. Touch [Buzzer setting] to bring up the buzzer volume setting window.

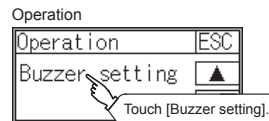

2. Touch [Buzzer volume] to bring up the setting window.

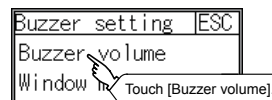

3. Touch a setting item to change the setting.
 (Buzzer volume: SHORT LONG OFF)

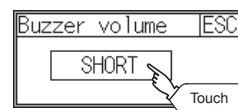

- After changing the settings, touch the [ESC] button to save the changes and close the setting window.

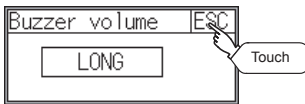

WINDOW MOVE BUZZER

- Touch [Buzzer setting] to bring up the buzzer volume setting window.

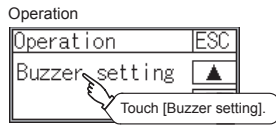

- Touch [Window move] to bring up the setting window.

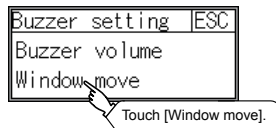

- Touch a setting item to change the setting. (Window move buzzer: ON OFF)

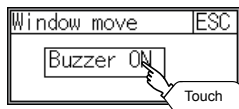

After changing the settings, touch the [ESC] button to save the changes and close the setting window.

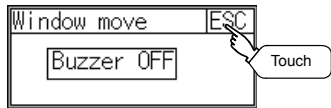

KEY REACTION

- Touch [▼] to bring up the [Key reaction] setting window.

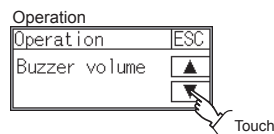

- Touch [Key reaction] to bring up the setting window.

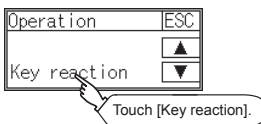

- Touch a setting item to change the setting.

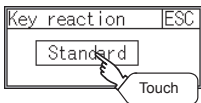

- After changing the settings, touch the [ESC] button to save the changes and close the setting window.

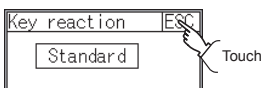

CLOCK SETTING

Setup the method to adjust the time between GOT data and the clock data of PLC CPU connected with GOT.

Setting	Contents
Adjust	Adjust the time of GOT clock data to the clock data of PLC CPU. Same as setting in [GOT setup] in [System Environment] of GT Designer2. Same as setting in [GOT Setup...] in [GOT Environmental Setting] of GT Designer3
Broadcast	Adjust the time of PLC CPU clock data to the clock data of GOT. Same as setting in [GOT setup] in [System Environment] of GT Designer2. Same as setting in [GOT Setup...] in [GOT Environmental Setting] of GT Designer3.
Both	Adjust and Broadcast can be used appropriately. Same as setting in [GOT setup] in [System Environment] of GT Designer2. Same as setting in [GOT Setup...] in [GOT Environmental Setting] of GT Designer3.
None	No adjustment of clock data.

- Touch [Clock setting] to bring up the setting window.

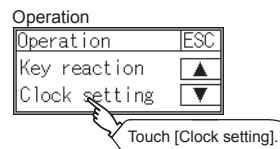

- Touch a setting item to change the setting.

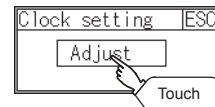

- After changing the settings, touch the button to save the changes and close the setting window.

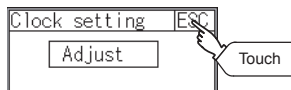

SECURITY

- Touch [Security] to bring up the setting window.

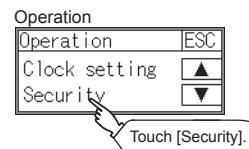

- Touching [Security level] displays the password input window. Inputting the password set in the password input window can change the security level.



- After changing the settings, touch the button to save the changes and close the setting window.

■ UTILITY CALL

1. Touch [Utility call] to bring up the setting window.

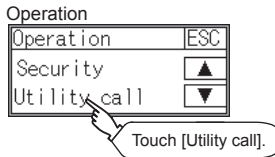

2. Touch [•] or [] displayed on the four corners of the setting screen. The [•] ↔ [] button repeats every time it is pressed. Change the part to be set as a key position to [•]. The key position can be set to the zero point.

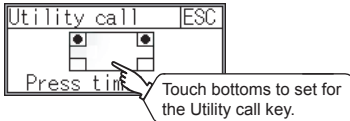

3. When the key position is specified by one point, the time to switch to the utility when the key position is kept pressing can be set. Touch the time area.
4. After changing the settings, touch the [ESC] button to save the changes and close the setting window.

8.10 CLOCK SETTINGS AND BATTERY STATUS DISPLAY

■ TIME SETTING AND DISPLAY

Time settings and displaying of the status of GOT built-in battery are possible.

Function	GT1030
Clock Display	Carry out the display and setup of PLC CPU or GOT's clock data.
GOT Internal Battery Voltage Status	Displays GOT internal battery voltage status.

■ CLOCK DISPLAY AND SETTING OPERATION

Displays and sets up the clock data on the GOT. When setting the clock data, change the clock data on the GOT and controller unless the clock setting is "unused". If you fail to change the clock data on the controller, the clock data on the GOT is not changed as well. When the GOT is not connected to the controller or is connected the controller which does not have the clock data, set the clock setting to "unused" first, and then change the clock data. The setup methods of clock data are shown below.

1. Touch either the date or time to be changed.

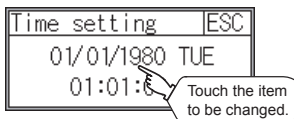

2. Enter date or time on the ten-key pad. The day of the week is displayed automatically according to the input date.

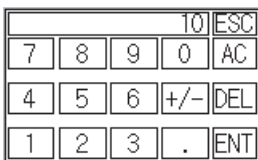

- ▶ "0" to "9": Use these keys to enter numerical values
- ▶ "ESC" : Closes the ten-key window without saving any value entered for the date or time

- ▶ "AC" : Deletes the entire string of numerical characters that are being entered
 - ▶ "DEL" : Deletes a digit from a string of numerical characters that are being entered
 - ▶ "ENT" : Enters the value for the date or clock that has been entered and closes the ten-key pad window
 - ▶ "+ / -" : Switches between positive and negative values (Only positive values are valid for the date or clock setting.)
 - ▶ ". " : Invalid key (not used)
3. After changing the settings, touch the button to save the changes and close the setting window.

■ GOT INTERNAL BATTERY VOLTAGE STATUS

Displays battery voltage status.

Display	Status
Normal	Normal
Low/None	Low voltage

9. MAINTENANCE AND INSPECTION

DANGER STARTUP/MAINTENANCE PRECAUTIONS

- When power is on, do not touch the terminals. Doing so can cause an electric shock or malfunction.
- Connect the battery correctly. Do not discharge, disassemble, heat, short, solder or throw the battery into the fire. Incorrect handling may cause the battery to generate heat, burst or take fire, resulting in injuries or fires.
- Before starting cleaning or terminal screw retightening, always switch off the power externally in all phases. Not switching the power off in all phases can cause a unit failure or malfunction. Undertightening can cause a short circuit or malfunction. Overtightening can cause a short circuit or malfunction due to the damage of the screws or unit.

CAUTION STARTUP/MAINTENANCE PRECAUTIONS

- Do not disassemble or modify the unit. Doing so can cause a failure, malfunction, injury or fire.
- Do not touch the conductive and electronic parts of the unit directly. Doing so can cause a unit malfunction or failure.
- The cables connected to the unit must be run in ducts or clamped. Not doing so can cause the unit or cable to be damaged due to the dangling, motion or accidental pulling of the cables or can cause a malfunction due to a cable connection fault.
- When unplugging the cable connected to the unit, do not hold and pull the cable portion. Doing so can cause the unit or cable to be damaged or can cause a malfunction due to a cable connection fault.
- Do not drop or apply any impact to the battery. If any impact has been applied, discard the battery and never use it. The battery may be damaged by the drop or impact.
- Before touching the unit, always touch grounded metal, etc. to discharge static electricity from human body, etc. Not doing so can cause the unit to fail or malfunction.

CAUTION DISPOSAL PRECAUTIONS

- When disposing of the product, handle it as industrial waste.

The GOT does not include consumable components that will cause the shorten life. However, the battery, liquid crystal screen and backlight has life length.

9.1 DAILY INSPECTION

Daily inspection items

No.	Inspection Item	Inspection Method	Criterion	Action	
1	GOT mounting status	Check for loose mounting screws.	Securely mounted	Retighten screws within the specified torque range	
2	Connection status	Loose terminal screws	Retighten screws with screwdriver	Not loose	Retighten terminal screws
		Loose connectors	Visual check	Not loose	Retighten connector fixing screws
3	Usage status	Dirt on protection sheet	Visual check	Not outstanding	Replace with new one
		Foreign material attachment	Visual check	No foreign matter sticking	Remove clean

9.2 PERIODIC INSPECTION

Yearly or half-yearly inspection items. The following inspection should also be performed when equipment has been moved or modified or the wiring changed.

No.	Inspection Item	Inspection Method	Criterion	Action	
1	Surrounding environment	Ambient temperature	Make measurement with thermometer or hygrometer	Display section 0 to 50°C Other portions 0 to 50°C	For use in control panel, temperature inside control panel is ambient temperature
		Ambient humidity	Measure	10 to 90%RH	
		Atmosphere	corrosive gas	No corrosive gas	
2	Power supply voltage check	24VDC Measure voltage across terminals.	20.4 to 26.4VDC	Change supply power	
3	Mounting status	Looseness	Move module	Should be mounted firmly	Retighten screws
		Dirt, foreign matter	Visual check	No dirt, foreign matter sticking	Remove, clean
4	Connection status	Loose terminal screws	Retighten screws with screwdriver	Not loose	Retighten connector fixing screws
		Loose connectors	Visual check	Not loose	Retighten connector fixing screws
5	Battery	Check the voltage status of the GOT built-in battery of [Time Setting & display] in the Utility.	(Preventive maintenance)	Replace with new battery when current battery has reached the specified life span, even if battery voltage is not displayed.	

9.3 CLEANING METHOD

Use the GOT always in a clean condition. To clean the GOT, wipe the dirty part with a soft cloth using neutral detergent.

Precautions for cleaning

Do not use chemicals such as thinner, organic solvents and strong acids, since they may cause the protective sheet to be deformed or the dissolvable paint on the surface to peel off. In addition, do not use spray solvents since they may cause the electrical failure of the GOT and peripheral devices. is used for backing up the clock data, alarm history or recipe data. It is recommended that you replace battery periodically. The battery voltage low detection can be confirmed by the utility screen and system alarm.

Battery replacement timing

When detecting voltage low, replace the battery immediately. Data can be saved for approximately a month after the battery voltage low detection and cannot be saved after that. If it exceeds a month from the voltage low detection to battery replacement, the clock data or D-drive* (Internal SRAM) data may become indefinite. Adjust the clock and format the D drive (Internal SRAM).

Example of alarm output to external device (lamp, buzzer, etc.)

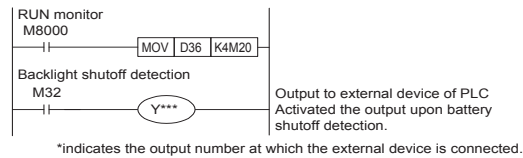

The following describes an example of outputting the battery voltage low signal from a FX series PLC to an external device with system information. Condition: The Write Device is "D20" and all data is used (the [SELECT ALL] button is clicked on the setting screen of drawing software) for the system information assignment.

D36 b12: Battery voltage low (System Signal 2-2) Turned on upon a battery voltage drop. Used as shown below in the sequence program.

HANDLING OF BATTERIES AND DEVICES WITH BUILT-IN BATTERIES IN EU MEMBER STATES

This section describes the precautions for disposing of waste batteries in EU member states and exporting batteries and/or devices with built-in batteries to EU member states.

Disposal precautions

In EU member states, there is a separate collection system for waste batteries. Dispose of batteries properly at the local community waste collection/recycling center. The following symbol is printed on the batteries and packaging of batteries and devices with built-in batteries used for Mitsubishi Graphic Operation Terminal (GOT).

This symbol is for EU member states only. The symbol is specified in the new EU Battery Directive (2006/66/EC) Article 20 "Information for end-users" and Annex II. The symbol indicates that batteries need to be disposed of separately from other wastes.



Exportation precautions

The new EU Battery Directive (2006/66/EC) requires the following when marketing or exporting batteries and/or devices with built-in batteries to EU member states.

- ▶ To print the symbol on batteries, devices, or their packaging
- ▶ To explain the symbol in the manuals of the products

Labelling

To market or export batteries and/or devices with built-in batteries, which have no symbol, to EU member states on September 26, 2008 or later, print the symbol shown in (1) on the GOT or their packaging.

Explaining the symbol in the manuals

To export devices incorporating Mitsubishi Graphic Operation Terminal to EU member states on September 26, 2008 or later, provide the latest manuals that include the explanation of the symbol.

If no Mitsubishi manuals or any old manuals without the explanation of the symbol are provided, separately attach an explanatory note regarding the symbol to each manual of the devices.

Backlight Shutoff Detection

The backlight is built into GOT for the liquid crystal display.

When GOT detects backlight shutoff, the POWER LED blinks green/orange alternately. The brightness of the backlight decreases with the lapse of usage period. When backlight shutoff is detected or the display becomes unclear, replace the backlight. For replacement of the backlight, contact Mitsubishi Electric at AZsupport@meau.com.

Life of backlight

The usable duration of backlight can be extended by setting to "Screen saving backlight off" in the utility of GOT (GOT set up).

Backlight shutoff detection and external alarm

When the GOT detects a backlight shutoff, the system information set with drawing software is turned on. You can issue a backlight shutoff of the GOT from the PLC to external devices (such as the lamp or buzzer), using system information. To avoid any screen touch operation by the user who misunderstands it is in screen saving mode, install an external alarm and interlock the loads that would cause danger.

10. WARRANTY

Please confirm the following product warranty details before using this product.

1. GRATIS WARRANTY TERM AND GRATIS WARRANTY RANGE

If any faults or defects (hereinafter "Failure") found to be the responsibility of Mitsubishi occurs during use of the product within the gratis warranty term, the product shall be repaired at no cost via the sales representative or Mitsubishi Service Company. However, if repairs are required onsite at domestic or overseas location, expenses to send an engineer will be solely at the customer's discretion. Mitsubishi shall not be held responsible for any re-commissioning, maintenance, or testing on-site that involves replacement of the failed module.

[Gratis Warranty Term]

The gratis warranty term of the product shall be for thirty-six (36) months after the date of purchase or delivery to a designated place. Note that after manufacture and shipment from Mitsubishi, the maximum distribution period shall be six (6) months, and the longest gratis warranty term after manufacturing shall be forty-two (42) months. The gratis warranty term of repair parts shall not exceed the gratis warranty term before repairs.

[Gratis Warranty Range]

1. The customer shall be responsible for the primary failure diagnosis unless otherwise specified. If requested by the customer, Mitsubishi Electric Corporation or its representative firm may carry out the primary failure diagnosis at the customer's expense. The primary failure diagnosis will, however, be free of charge should the cause of failure be attributable to Mitsubishi Electric Corporation.
2. The range shall be limited to normal use within the usage state, usage methods and usage environment, etc., which follow the conditions and precautions, etc., given in the instruction manual, user's manual and caution labels on the product.
3. Even within the gratis warranty term, repairs shall be charged for in the following cases.
 - Failure occurring from inappropriate storage or handling, carelessness or negligence by the user. Failure caused by the user's

hardware or software design.

- Failure caused by unapproved modifications, etc., to the product by the user.
- When the Mitsubishi product is assembled into a user's device, Failure that could have been avoided if functions or structures, judged as necessary in the legal safety measures the user's device is subject to or as necessary by industry standards, had been provided.
- Failure that could have been avoided if consumable parts designated in the instruction manual had been correctly serviced or replaced.
- Replacing consumable parts such as the battery, backlight and fuses.
- Failure caused by external irresistible forces such as fires or abnormal voltages, and Failure caused by force majeure such as earthquakes, lightning, wind and water damage.
- Failure caused by reasons unpredictable by scientific technology standards at time of shipment from Mitsubishi.
- Any other failure found not to be the responsibility of Mitsubishi or that admitted not to be so by the user.

2. ONEROUS REPAIR TERM AFTER DISCONTINUATION OF PRODUCTION

1. Mitsubishi shall accept onerous product repairs for seven (7) years after production of the product is discontinued. Discontinuation of production shall be notified with Mitsubishi Technical Bulletins, etc.
2. Product supply (including repair parts) is not available after production is discontinued.

3. OVERSEAS SERVICE

Overseas, repairs shall be accepted by Mitsubishi's local overseas FA Center. Note that the repair conditions at each FA Center may differ.

4. EXCLUSION OF LOSS IN OPPORTUNITY AND SECONDARY LOSS FROM WARRANTY LIABILITY

Regardless of the gratis warranty term, Mitsubishi shall not be liable for compensation to damages caused by any cause found not to be the responsibility of Mitsubishi, loss in opportunity, lost profits incurred to the user by Failures of Mitsubishi products, special damages and secondary damages whether foreseeable or not, compensation for accidents, and compensation for damages to products other than Mitsubishi products, replacement by the user, maintenance of on-site equipment, start-up test run and other tasks.

5. CHANGES IN PRODUCT SPECIFICATIONS

The specifications given in the catalogs, manuals or technical documents are subject to change without prior notice.

6. PRODUCT APPLICATION

1. In using the Mitsubishi graphic operation terminal, the usage conditions shall be that the application will not lead to a major accident even if any problem or fault should occur in the graphic operation terminal device, and that backup and fail-safe functions are systematically provided outside of the device for any problem or fault.
2. The Mitsubishi graphic operation terminal has been designed and manufactured for applications in general industries, etc. Thus, applications in which the public could be affected such as in nuclear power plants and other power plants operated by respective power companies, and applications in which a special quality assurance system is required, such as for Railway companies or Public service purposes shall be excluded from the graphic operation terminal applications. In addition, applications in which human life or

property that could be greatly affected, such as in aircraft, medical applications, incineration and fuel devices, manned transportation equipment for recreation and amusement, and safety devices, shall also be excluded from the graphic operation terminal range of applications.

However, in certain cases, some applications may be possible, providing the user consults the local Mitsubishi representative outlining the special requirements of the project, and providing that all parties concerned agree to the special circumstances, solely at our discretion.

In some of three cases, however, Mitsubishi Electric Corporation may consider the possibility of an application, provided that the customer notifies Mitsubishi Electric Corporation of the intention, the application is clearly defined and any special quality is not required.

MITSUBISHI ELECTRIC AUTOMATION, INC.

500 Corporate Woods Parkway, Vernon Hills, IL 60061
Ph 847.478.2100 • Fx 847.478.2253

us.MitsubishiElectric.com/fa/en/support

January, 2016 • ©2016, Mitsubishi Electric Automation, Inc. •
Specifications subject to change without notice. • All rights reserved

AZ-JY997D24701Y



Mitsubishi Electric Automation, Inc.