

ifm electronic



Operating instructions
Electronic pressure sensor

efector500[®]

PF265x

UK

704907 / 00 08 / 2010

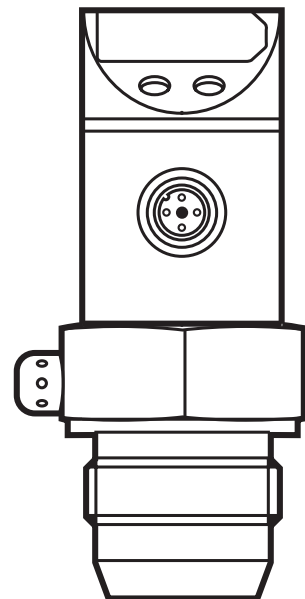

Contents

1	Preliminary note.....	3
1.1	Symbols used	3
2	Safety instructions	3
3	Functions and features	4
3.1	Applications	4
4	Function.....	4
4.1	Processing of the measured signals.....	4
4.2	Pressure monitoring / switching function	5
4.3	Pressure monitoring/ analogue function	5
5	Installation.....	7
6	Electrical connection.....	8
7	Operating and display elements	10
8	Menu.....	11
8.1	Menu structure.....	11
8.2	Menu explanation	12
9	Parameter setting	13
9.1	Parameter setting general	13
9.2	Configuring the display (optional).....	14
9.3	Setting the output signal	15
9.3.1	Setting the output function.....	15
9.3.2	Setting the switching limits	15
9.3.3	Scaling the analogue value	15
9.4	User settings (optional).....	15
9.4.1	Zero-point calibration.....	15
9.4.2	Calibration reset	15
9.4.3	Setting the delay time for the switching outputs	16
9.4.4	Setting the output polarity.....	16
9.4.5	Setting the damping for the switching signal	16
9.4.5	Setting the damping for the analogue signal	16
9.5	Service functions	16
9.5.1	Reading the min./max. values for the system pressure.....	16

10 Operation.....	16
10.1 Read the set parameter values	17
10.2 Fault indication	17
10.3 Cleaning of the filter cover.....	17
11 Scale drawing	18
12 Technical data.....	19
12.1 Setting ranges	21

1 Preliminary note

1.1 Symbols used

- ▶ Instruction
- > Reaction, result
- [...] Designation of buttons, switches or indications
- Cross-reference



Important note
Non-compliance can result in malfunctions or interference.

2 Safety instructions

- Read this document before installing the unit. Ensure that the product is suitable for your application without any restrictions.
- Non-adherence to the operating instructions or technical data can lead to personal injury and/or damage to property.
- In all applications check compliance of the product materials (→ 12 Technical data) with the media to be measured.
- Use in gases at pressures > 25 bar only after contacting the manufacturer ifm.
- For units with cULus approval and the scope of validity cULus → 6 Electrical connection.

3 Functions and features

The pressure sensor detects the system pressure of machines and installations.

3.1 Applications

Type of pressure: relative pressure

Order no.	Measuring range		Permissible overload pressure		Bursting pressure	
	bar	inHg	bar	inHg	bar	inHg
PF2609	-0.99...1.00	-30...30	20	590	50	1 475
	bar	PSI	bar	PSI	bar	PSI
PF2652	-1...100	-10...1450	200	2 900	650	9 425
PF2653	-1...25	-15...363	100	1 450	350	5 070
PF2654	-0.5...10	-7...145	50	725	150	2 175
PF2656	-0.13...2.5	-1.8...36.3	20	290	50	725
	mbar	PSI	bar	PSI	bar	PSI
PF2657	-50...1 000	-0.7...14.5	10	145	30	450
	mbar	inH2O	bar	inH2O	bar	inH2O
PF2658	-13...250	-5.0...100	10	4 000	30	12 000

$$\text{MPa} = \text{bar} \div 10 \quad / \quad \text{kPa} = \text{bar} \times 100$$



Static and dynamic overpressures exceeding the indicated overload pressure are to be avoided by taking appropriate measures.

The indicated bursting pressure must not be exceeded. Even if the bursting pressure is exceeded only for a short time, the unit can be destroyed.

NOTE: Risk of injury!

4 Function

4.1 Processing of the measured signals

- The unit displays the current system pressure.
- It generates 2 output signals according to the parameter setting.

OUT1	• switching signal for pressure limit values
OUT2	• switching signal for pressure limit values • analogue signal 4...20 mA • analogue signal 0...10 V

4.2 Pressure monitoring / switching function

OUTx changes its switching state if it is above or below the set switching limits (SPx, rPx). The following switching functions can be selected:

- Hysteresis function / normally open: [OUx] = [Hno] (→ fig. 1).
- Hysteresis function / normally closed: [OUx] = [Hnc] (→ fig. 1).

First the set point (SPx) is set, then the reset point (rPx) at the requested distance.

- Window function / normally open: [OUx] = [Fno] (→ fig. 2).
- Window function / normally closed: [OUx] = [Fnc] (→ fig. 2).

The width of the window can be set by means of the distance between SPx and rPx. SPx = maximum value, rPx = minimum value.

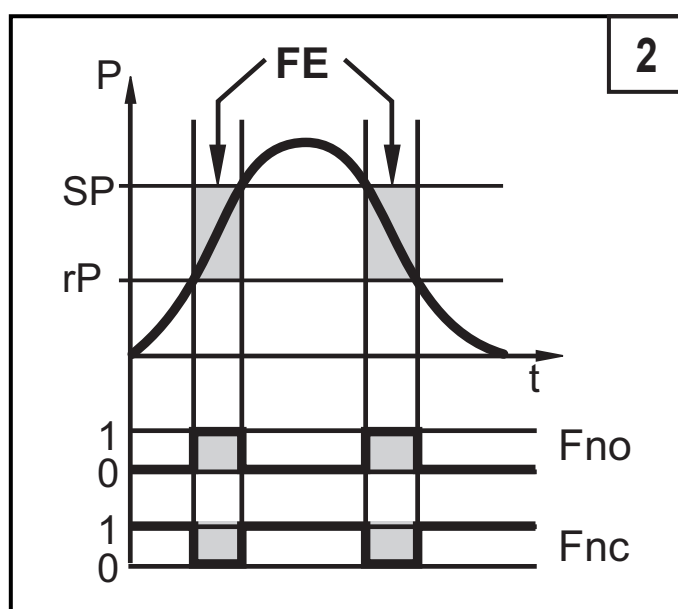
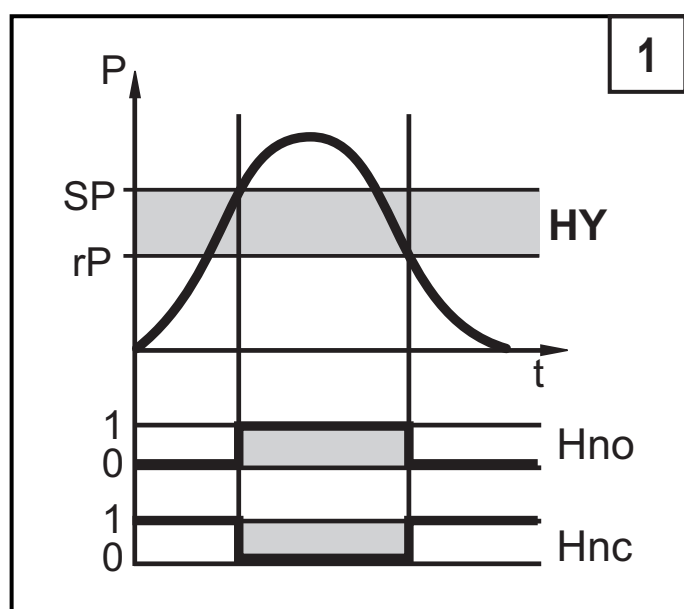

P = system pressure; HY = hysteresis; FE = window

4.3 Pressure monitoring/ analogue function

The analogue signal can be set.

- [OU2] defines whether the set measuring range is provided as a 4...20 mA signal ([OU2] = [I]) or a 0...10 V signal ([OU2] = [U]).
- By setting the parameter ASP you define the measured value at which the output signal is 4 mA / 0 V.
- By setting the parameter AEP you define the measured value at which the output signal is 20 mA / 10 V.

Minimum distance between [ASP] and [AEP] = 25 % of the final value of the measuring range (turn down 1:4).

Current output

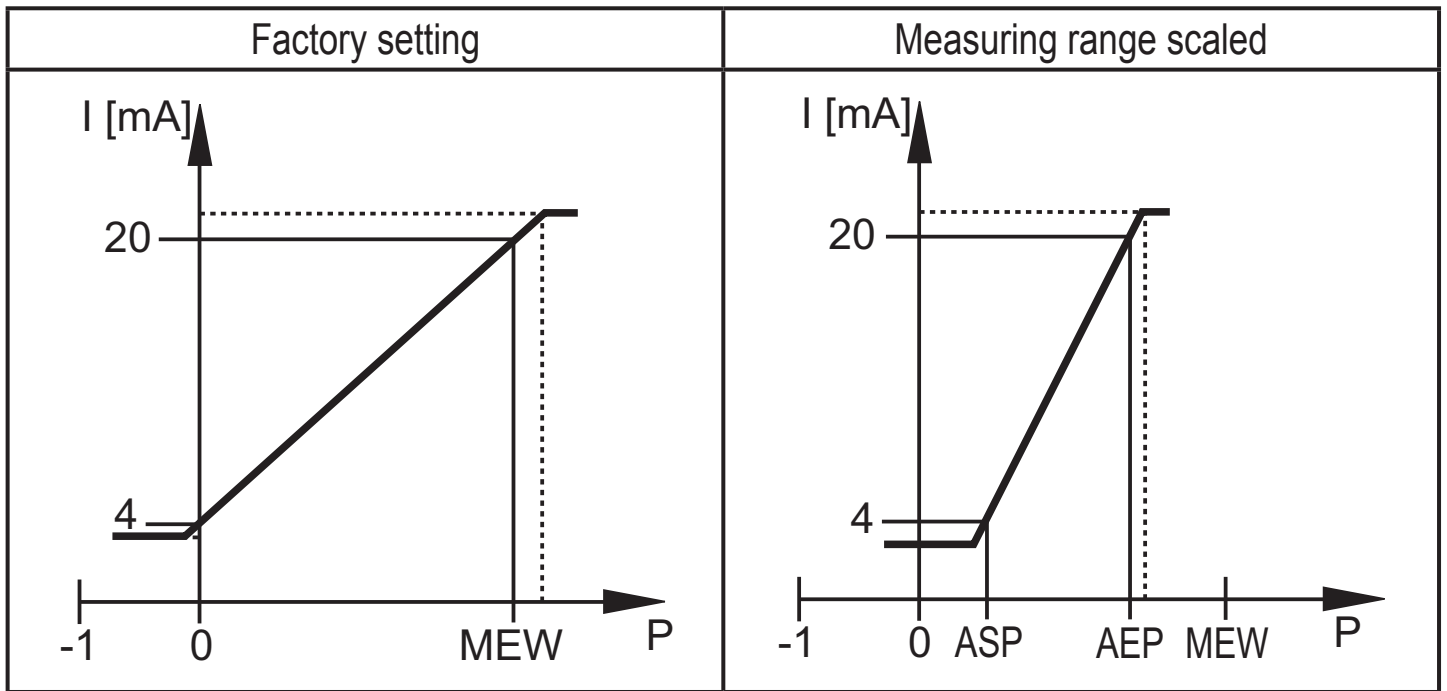

P = system pressure, MEW = final value of the measuring range

The output signal is between 4 and 20 mA. It is also indicated:

- System pressure above the measuring range: output signal > 20 mA .
- System pressure below the measuring range: output signal between 4 and 3.2 mA.

Voltage output

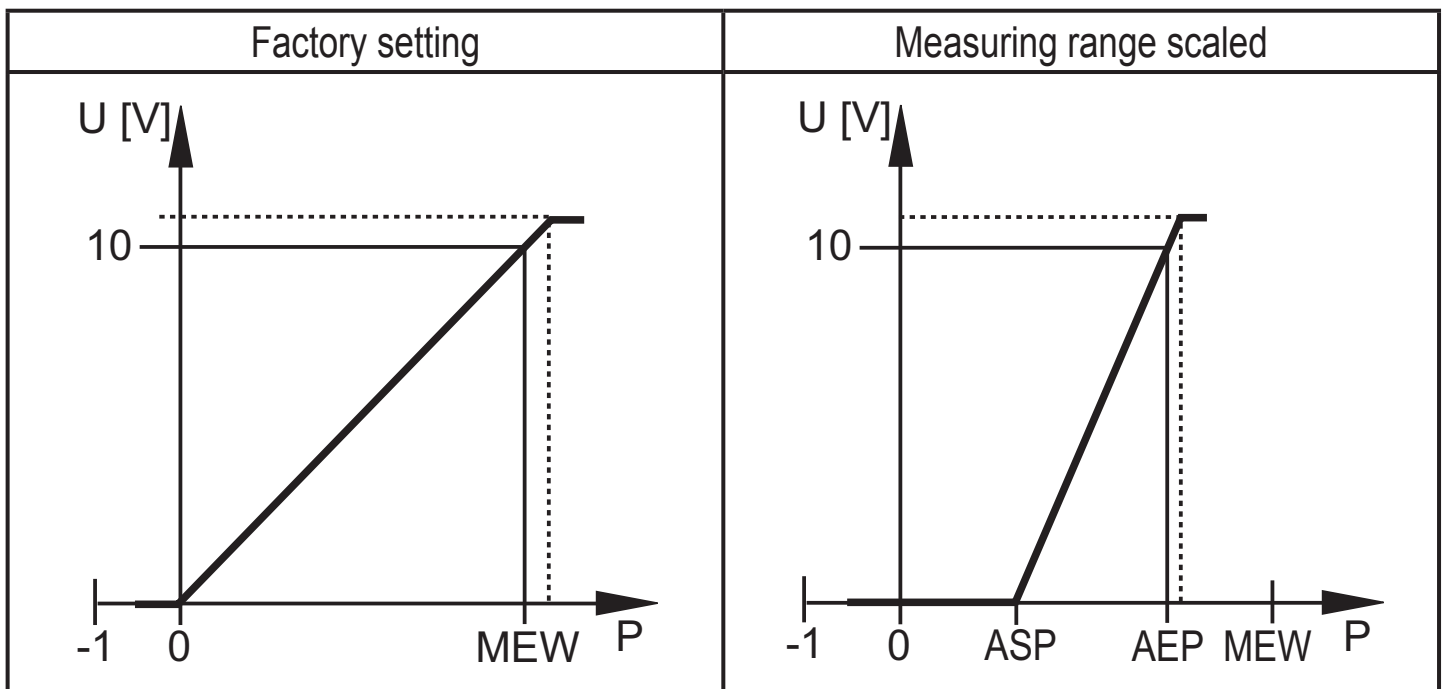

P = system pressure, MEW = final value of the measuring range

The output signal is between 0 and 10 V. It is also indicated:

- System pressure above the measuring range: output signal > 10 V.

5 Installation



Ensure that no pressure is applied to the installation while mounting or removing the sensor.

- ▶ Screw the sensor into a G 1 process fitting.
- ▶ Tighten the sensor with a spanner. Tightening torque: 20 Nm.

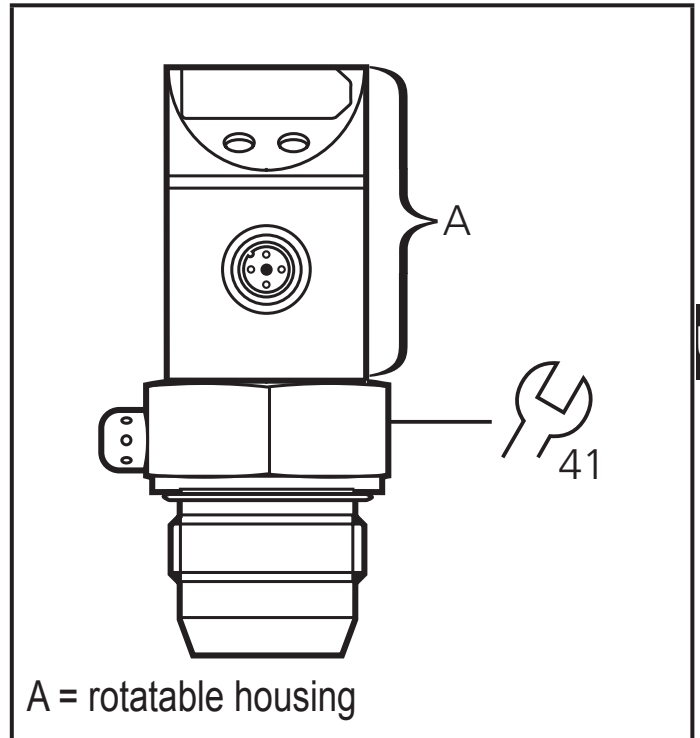

The unit is adaptable for various G 1 process fittings. G 1 process adapters to be ordered separately as accessories.

- ▶ Mount the adapter (B) to the sensor.
- ▶ Fix sensor + adapter by means of a coupling nut, a clamp flange or similar (A) to the process connection.

If it is not possible to slide the fixing element (A) down over the top of the sensor: slide it up over the bottom of the sensor before the adapter is mounted.

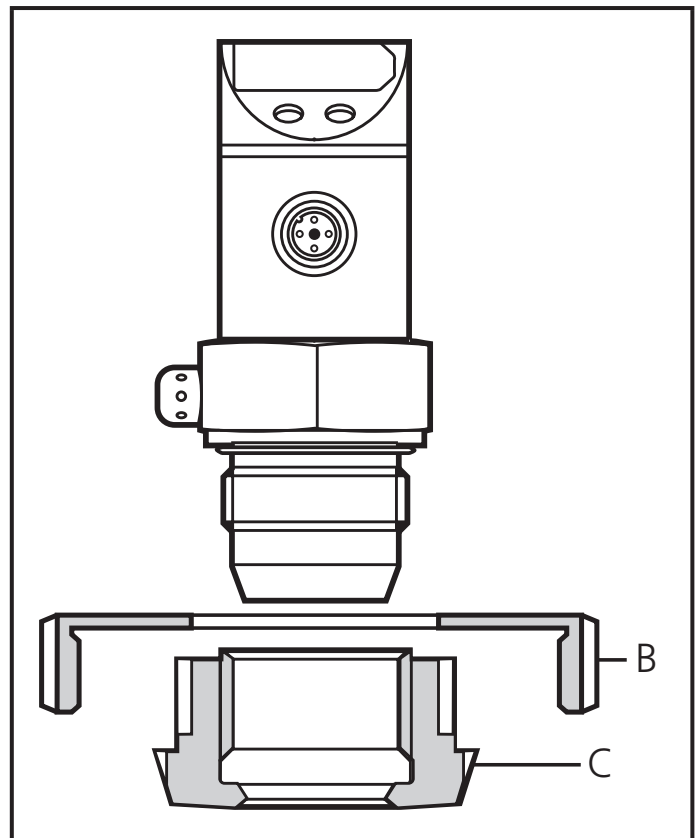

Montage des Adapters

- ▶ Screw the unit into the adapter until it is hand-tight. Do not damage the sealing chamfers.

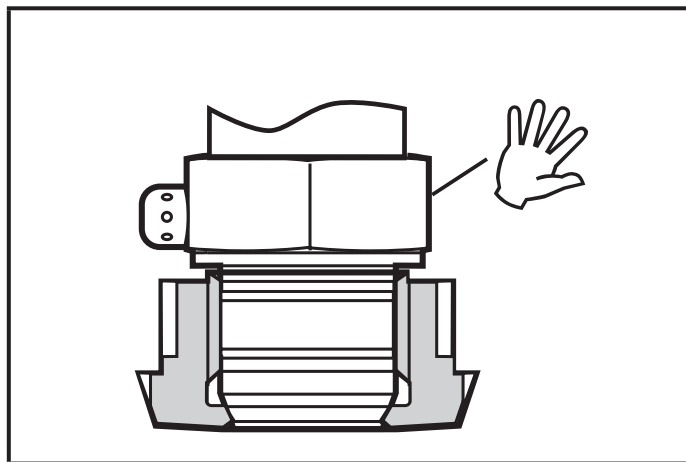

- ▶ Clamp sensor and adapter into a clamping device (C). Tighten the clamping device only slightly so that the adapter does not warp. The sealing chamfers (D) must not be damaged.
- ▶ Tighten the sensor using a spanner.
Tightening torque: 20 Nm.

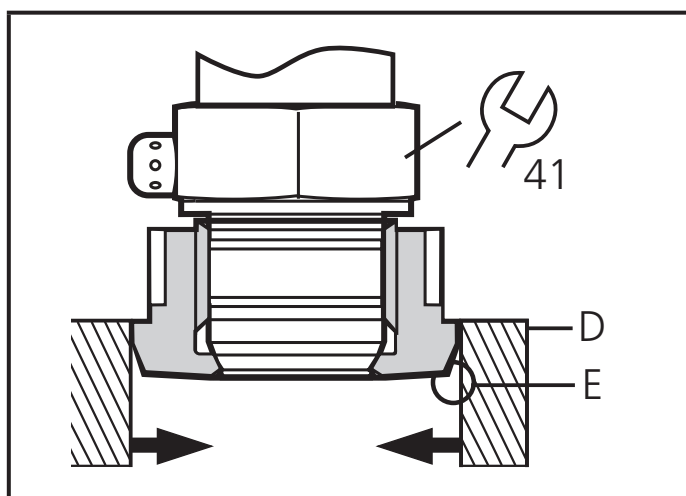

Welding adapter

First weld the adapter, then mount the sensor. Follow the instructions included with the adapter.

6 Electrical connection



The unit must be connected by a qualified electrician.

The national and international regulations for the installation of electrical equipment must be adhered to.

Voltage supply to EN50178, SELV, PELV.

For units with cULus approval and the scope of validity cULus: The device shall be supplied from an isolating transformer having a secondary Listed fuse rated as noted in the following table.

Overcurrent protection		
Control-circuit wire size		Maximum protective device rating Ampere
AWG	(mm ²)	
26	(0.13)	1
24	(0.20)	2
22	(0.32)	3
20	(0.52)	5
18	(0.82)	7
16	(1.3)	10

UK

The Sensor shall be connected only by using any R/C (CYJV2) cord, having suitable ratings.

- ▶ Disconnect power.
- ▶ Connect the unit as follows:

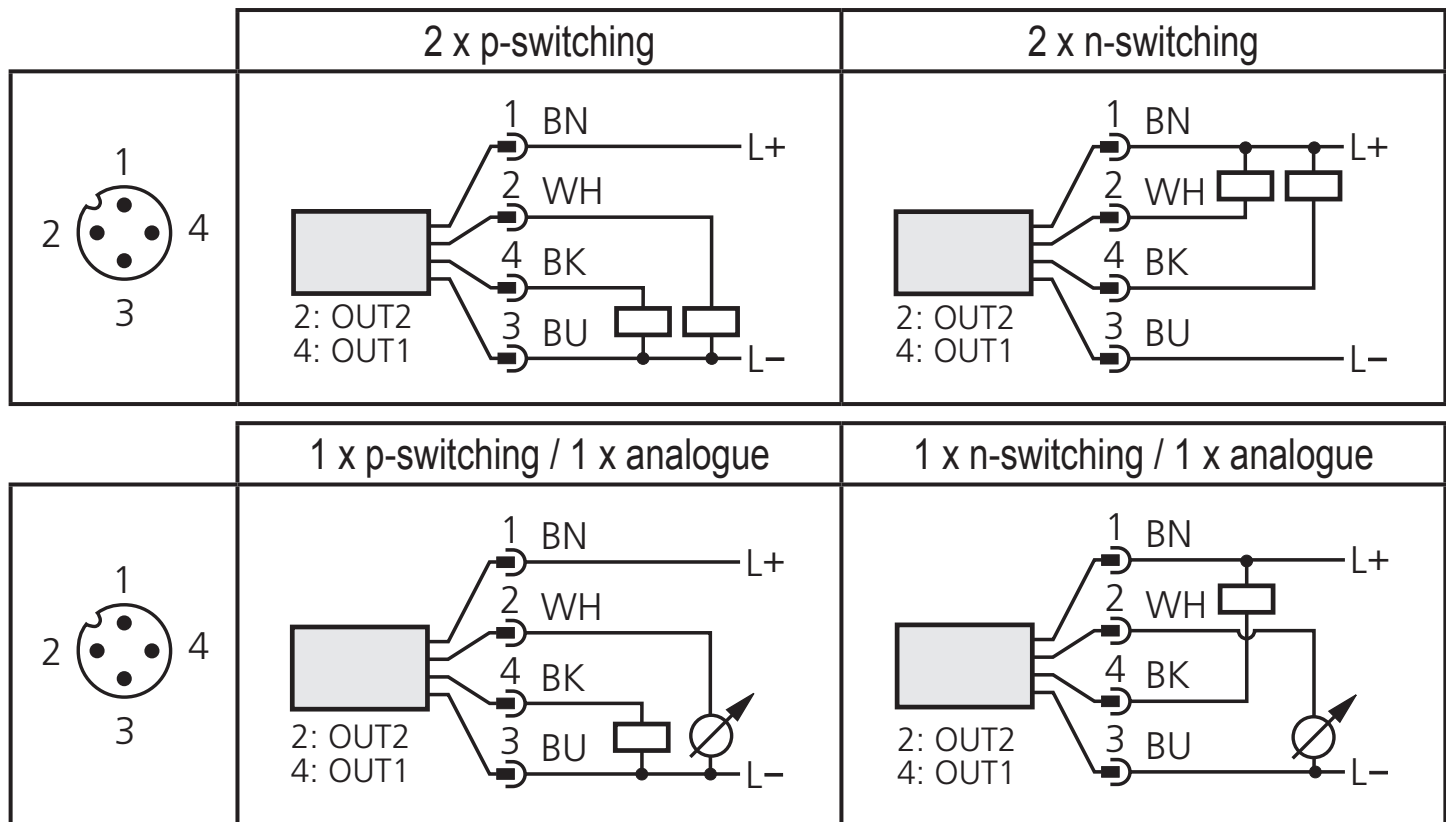

Core colours of ifm sockets:

1 = BN (brown), 2 = WH (white), 3 = BU (blue), 4 = BK (black)

7 Operating and display elements

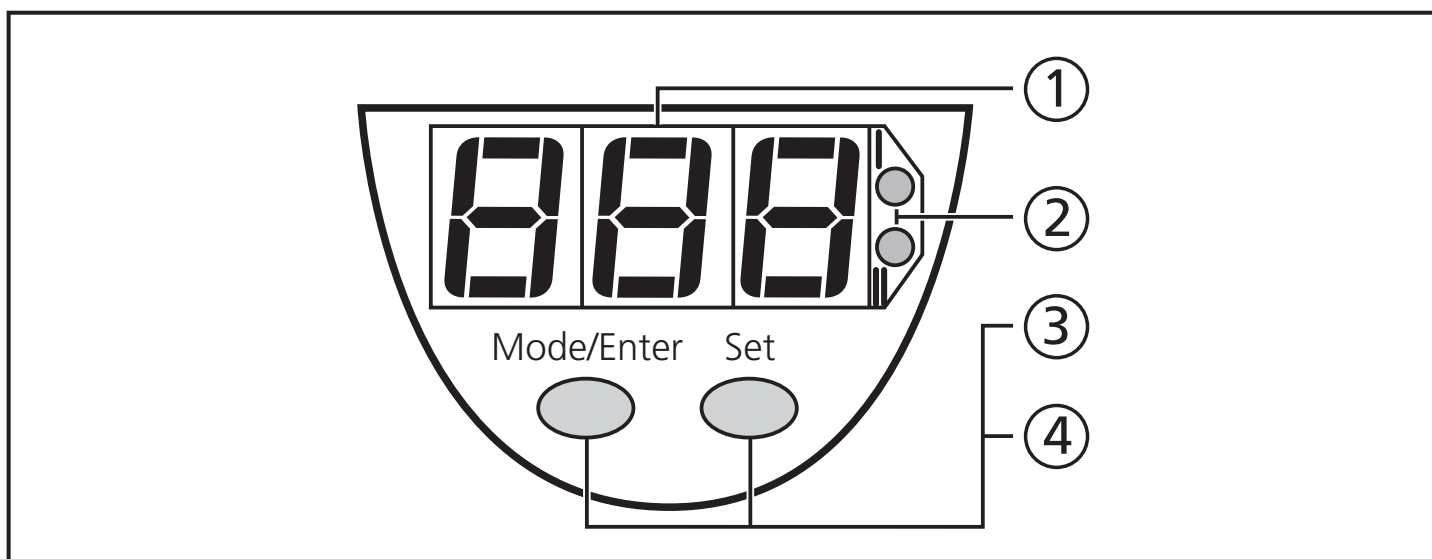

1: 7-segment display

- Display of the system pressure¹⁾,
- display of parameters and parameter values.

2: 2 x LED red

- Switching status; lights if output I / II has switched.

3: Set button

- Setting of the parameter values (scrolling by holding pressed; incremental by pressing briefly).

4: Mode/Enter button

- Selection of the parameters and acknowledgement of the parameter values.

¹⁾ 3-digit display in the minus range: -.XX = - 0,XX
PSI indication for PF2652: 1/10 of the PSI value is displayed.

8 Menu

8.1 Menu structure

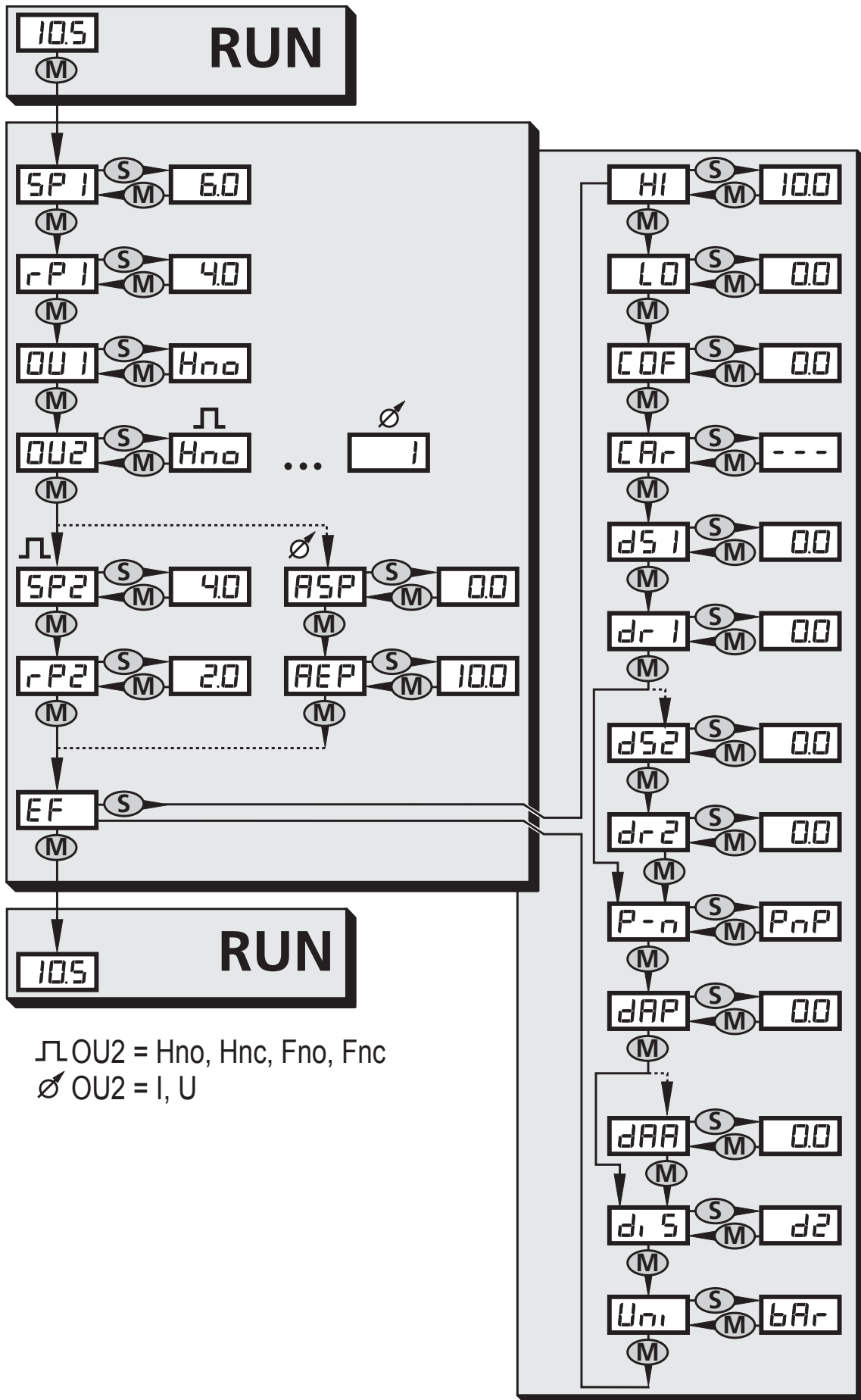

UK

8.2 Menu explanation

SP1/rP1	Maximum / minimum value for system pressure, at which output 1 changes its switching status.
OU1	Output function for OUT1: <ul style="list-style-type: none"> • Switching signal for the limit values: hysteresis function [H ..] or window function [F ..], normally open [. no] or normally closed [. nc] each.
OU2	Output function for OUT2: <ul style="list-style-type: none"> • Switching signal for the limit values: hysteresis function [H ..] or window function [F ..], normally open [. no] or normally closed [. nc] each.. • Analogue signal for the current system pressure: 4...20 mA [I], 0...10 V [U].
SP2/rP2	Maximum / minimum value for system pressure, at which output 2 changes its switching status.
ASP	Analogue start point for the system pressure: measured value at which 4 mA / 0 V are output.
AEP	Analogue end point for the system pressure: measured value at which 20 mA / 10 V are output.
EF	Extended functions / Opening menu level 2.
HI	Maximum value memory for the system pressure.
LO	Minimum value memory for the system pressure.
COF	Zero point calibration.
CAr	Calibration reset.
dS1/dS2	Switch-on delay for OUT1/OUT2.
dr1/dr2	Reset delay for OUT1/OUT2.
P-n	Output polarity: pnp / npn
dAP	Damping for the switching outputs.
dAA	Damping for the analogue signal.
diS	Update rate and orientation of the display.
Uni	Standard unit of measurement for the system pressure.

9 Parameter setting

During the parameter setting process the unit remains in the operating mode. It continues its monitoring function with the existing parameters until parameter setting has been terminated.

9.1 Parameter setting general

Each parameter setting requires 3 steps:

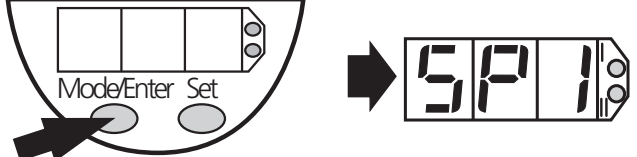
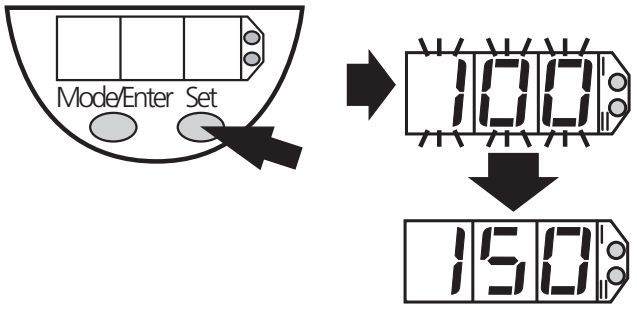
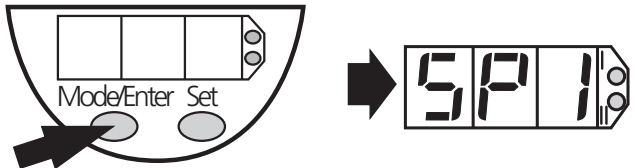
<p>1</p>	<p>Selecting parameter</p> <ul style="list-style-type: none"> ▶ Press [Mode/Enter] until the requested parameter is displayed. 	
<p>2</p>	<p>Setting the parameter value</p> <ul style="list-style-type: none"> ▶ Press [Set] and keep the button pressed. > Current setting value of the parameter bit flashes for 5 s. > After 5 s: Setting value is changed: incremental by pressing briefly or scrolling by holding pressed. 	
<p>The numerical values are incremented continuously. If the value is to be reduced: Let the display move to the maximum setting value. Then the cycle starts again at the minimum setting value.</p>		
<p>3</p>	<p>Acknowledge parameter value</p> <ul style="list-style-type: none"> ▶ Press [Mode/Enter] briefly. > The parameter is displayed again. The new setting value is stored. 	
<p>Set more parameters</p> <ul style="list-style-type: none"> ▶ Start again with step 1. 		
<p>Finishing parameter setting</p> <ul style="list-style-type: none"> ▶ Press [Mode/Enter] several times until the current measured value is displayed or wait for 15 s. > The unit returns to the operating mode. 		

UK

- Changing from menu level 1 to menu level 2

- ▶ Press [Mode/Enter] until [EF] is displayed..
- ▶ Press [Set] briefly.
- > The first parameter of the submenu is displayed (here: [HI]).

- Locking / unlocking

The unit can be locked electronically to prevent unintentional wrong settings.

- ▶ Ensure that the unit is in the normal operating mode.
- ▶ Press [Mode/Enter] + [Set] for 10 s.
- > Indication goes out briefly (acknowledgement of locking / unlocking).



Units are delivered from the factory in the unlocked state.

With the unit in the locked state [Loc] is indicated briefly when you try to change parameter values.

- Timeout

If no button is pressed for 15 s while the parameters are being set, the unit returns to the operating mode with unchanged values.

9.2 Configuring the display (optional)

<ul style="list-style-type: none"> ▶ Select [Uni] and set the unit of measurement: <ul style="list-style-type: none"> - bAr (= bar / mbar), - PSI, - PA (= MPa / kPa) - H2O (= inH2O, only PF2658), - inH (= inHg, only PF2609). 	
<ul style="list-style-type: none"> ▶ Select [diS] and set update rate and orientation of the display <ul style="list-style-type: none"> - [d1]: Update of the measured value every 50 ms. - [d2]: Update of the measured value every 200 ms. - [d3]: Update of the measured value every 600 ms. - [Ph] = display of the measured peak value remains for a short time (peak hold). - [rd1], [rd2], [rd3], [rPh]: Display like d1, d2, d3, Ph; rotated by 180°. - [OFF]: The display is deactivated in the operating mode. If one of the buttons is pressed, the current measured value is displayed for 15 s. Another press of the Mode/Enter button opens the Display mode. The LEDs remain active even if the display is deactivated. 	

9.3 Setting the output signal

9.3.1 Setting the output function

<ul style="list-style-type: none">▶ Select [OU1] and set the switching function:<ul style="list-style-type: none">- [Hno] = hysteresis function / normally open,- [Hnc] = hysteresis function / normally closed,- [Fno] = window function / normally open,- [Fnc] = window function / normally closed.	OU 1
<ul style="list-style-type: none">▶ Select [OU2] and set the switching function:<ul style="list-style-type: none">- [Hno] = hysteresis function / normally open,- [Hnc] = hysteresis function / normally closed,- [Fno] = window function / normally open,- [Fnc] = window function / normally closed,- [I] = current signal proportional to the pressure 4...20 mA,- [U] = voltage signal proportional to the pressure 0...10 V.	OU 2

UK

9.3.2 Setting the switching limits

<ul style="list-style-type: none">▶ Select [SP1] / [SP2] and set the value at which the output switches.	SP 1 SP 2
<ul style="list-style-type: none">▶ Select [rP1] / [rP2] and set the value at which the output switches back. rPx is always lower than SPx. The unit only accepts values which are lower than SPx.	rP 1 rP 2

9.3.3 Scaling the analogue value

<ul style="list-style-type: none">▶ Select [ASP] and set measured value at which 4 mA / 0 V are output.▶ Select [AEP] and set measured value at which 20 mA / 10 V are output. Minimum distance between ASP and AEP = 25 % of the final value of the measuring range (scaling factor 1:4).	ASP AEP
---	------------

9.4 User settings (optional)

9.4.1 Zero-point calibration

<ul style="list-style-type: none">▶ Select [COF] and set a value between -5% and 5% of the final value of the measuring range. The internal measured value "0" is shifted by this amount.	COF
---	-----

9.4.2 Calibration reset

<ul style="list-style-type: none">▶ Select [CAr].▶ Press [SET] until [---] is displayed.▶ Press [Mode/Enter] briefly.	CAr
---	-----

9.4.3 Setting the delay time for the switching outputs

<p>[dS1] / [dS2] = switch-on delay for OUT1 / OUT2. [dr1] / [dr2] = switch-off delay for OUT1 / OUT2.</p> <ul style="list-style-type: none">▶ Select [dS1], [dS2], [dr1] or [dr2], set value between 0.1 und 50 s (at 0.0 the delay time is not active)	
---	---

9.4.4 Setting the output polarity

<ul style="list-style-type: none">▶ Select [P-n] and set [PnP] or [nPn].	
--	---

9.4.5 Setting the damping for the switching signal

<ul style="list-style-type: none">▶ Select [dAP] and set value between 0.01 and 4.00 s (at 0.00 = [dAP] is not active). <p>dAP value = response time between pressure change and change of the switching status in seconds. [dAP] influences the switching frequency: $f_{\max} = 1 \div 2dAP$. [dAP] also affects the display.</p>	
--	--

9.4.5 Setting the damping for the analogue signal

<ul style="list-style-type: none">▶ Select [dAA] and set a value: 0,0 - 0,1- 0,5 or 2,0 s (at 0.0 = [dAA] is not active). <p>dAA value = response time between pressure change and change of the analogue signal in seconds.</p>	
--	---

9.5 Service functions

9.5.1 Reading the min./max. values for the system pressure

<ul style="list-style-type: none">▶ [Select [HI] or [LO], press [Set] briefly. [HI] = maximum value, [LO] = minimum value. <p>Delete memory:</p> <ul style="list-style-type: none">▶ Select [HI] or [LO].▶ Press [SET] until [---] is displayed.▶ Press [Mode/Enter] briefly.	
---	---

10 Operation

After power on of the supply voltage the unit is in the Run mode (= normal operation). It carries out its measurement and evaluation functions and generates output signals according to the set parameters.

Operating indicators → 7 Operating and display elements.

10.1 Read the set parameter values

- ▶ Press [Mode/Enter] until the requested parameter is displayed.
- ▶ Press [Set] briefly.
- > The unit displays the corresponding parameter value for about 15 s. After another 15 s the unit returns to the Run mode.

10.2 Fault indication

[OL]	Overload (pressure above measuring range of the sensor).
[UL]	Underload (pressure below measuring range of the sensor).
[SC1]	Flashing: short circuit in the switching output 1*.
[SC2]	Flashing: short circuit in the switching output 2*.
[SC]	Flashing: short circuit in both switching outputs*.

*The output concerned is switched off as long as the short circuit exists.

10.3 Cleaning of the filter cover

If viscous and residues producing media clog the filter cover of the sensor (and thus reduce the measuring accuracy slightly), you can clean it.

- ▶ Unscrew the filter cover (B) (use a pair of pliers with plastic-covered jaws for this).
- ▶ Clean the cover thoroughly.

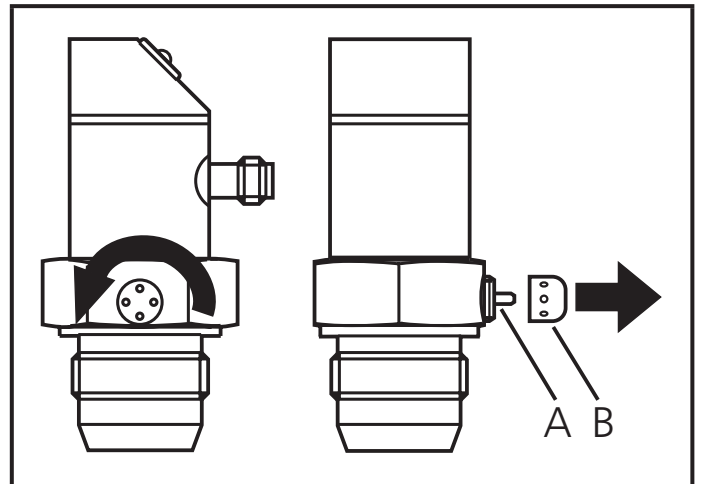

The vent (A) should only be cleaned by skilled personnel and with utmost care. Possible medium residues must not be compressed and pressed into the vent. This could clog the filter system and reduce the measuring accuracy of the sensor.

- ▶ Screw the filter cover again tightly.

11 Scale drawing

PF2609, PF2653...PF2658

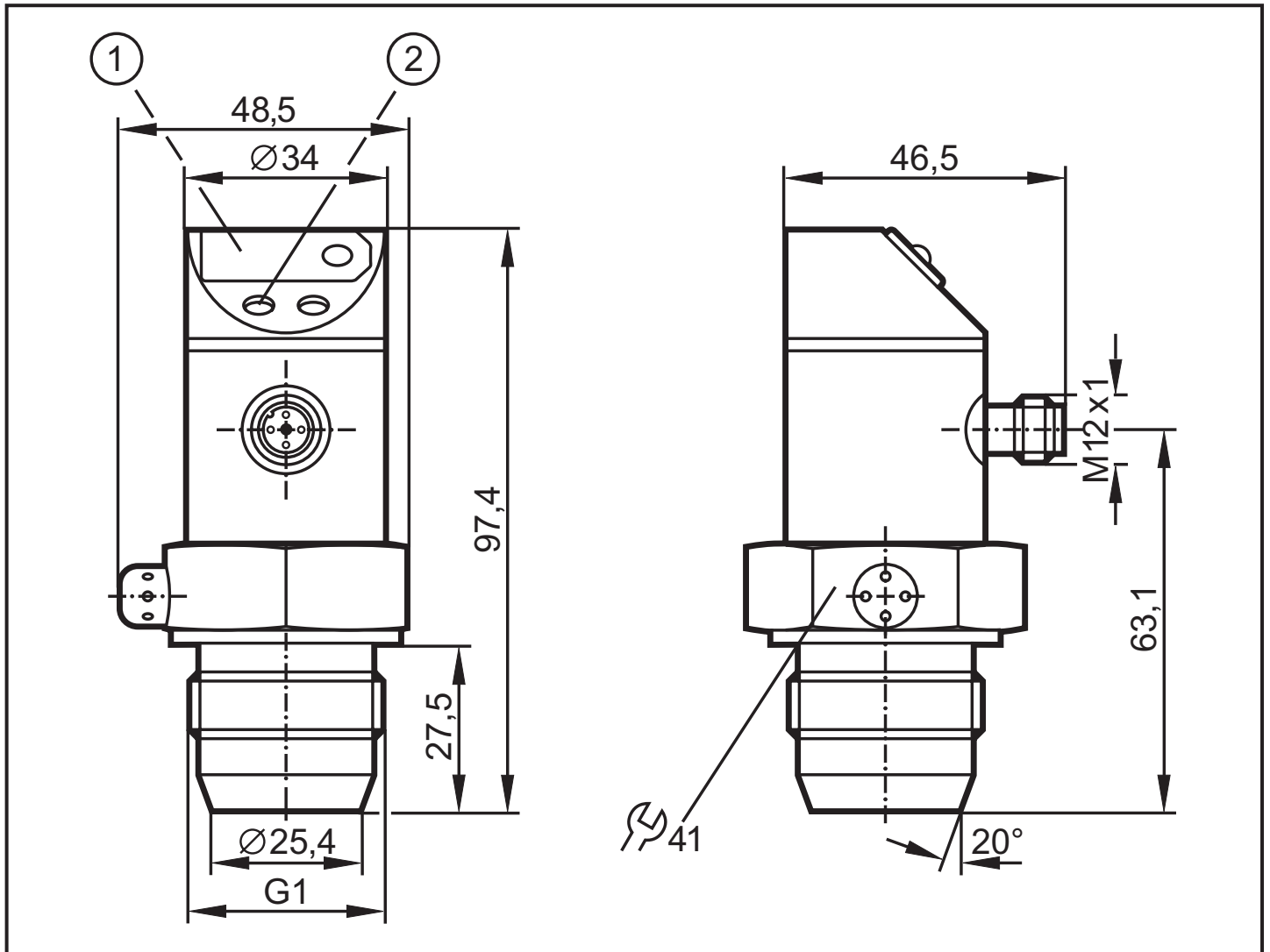

Dimensions are in millimeters
1: display; 2: programming buttone

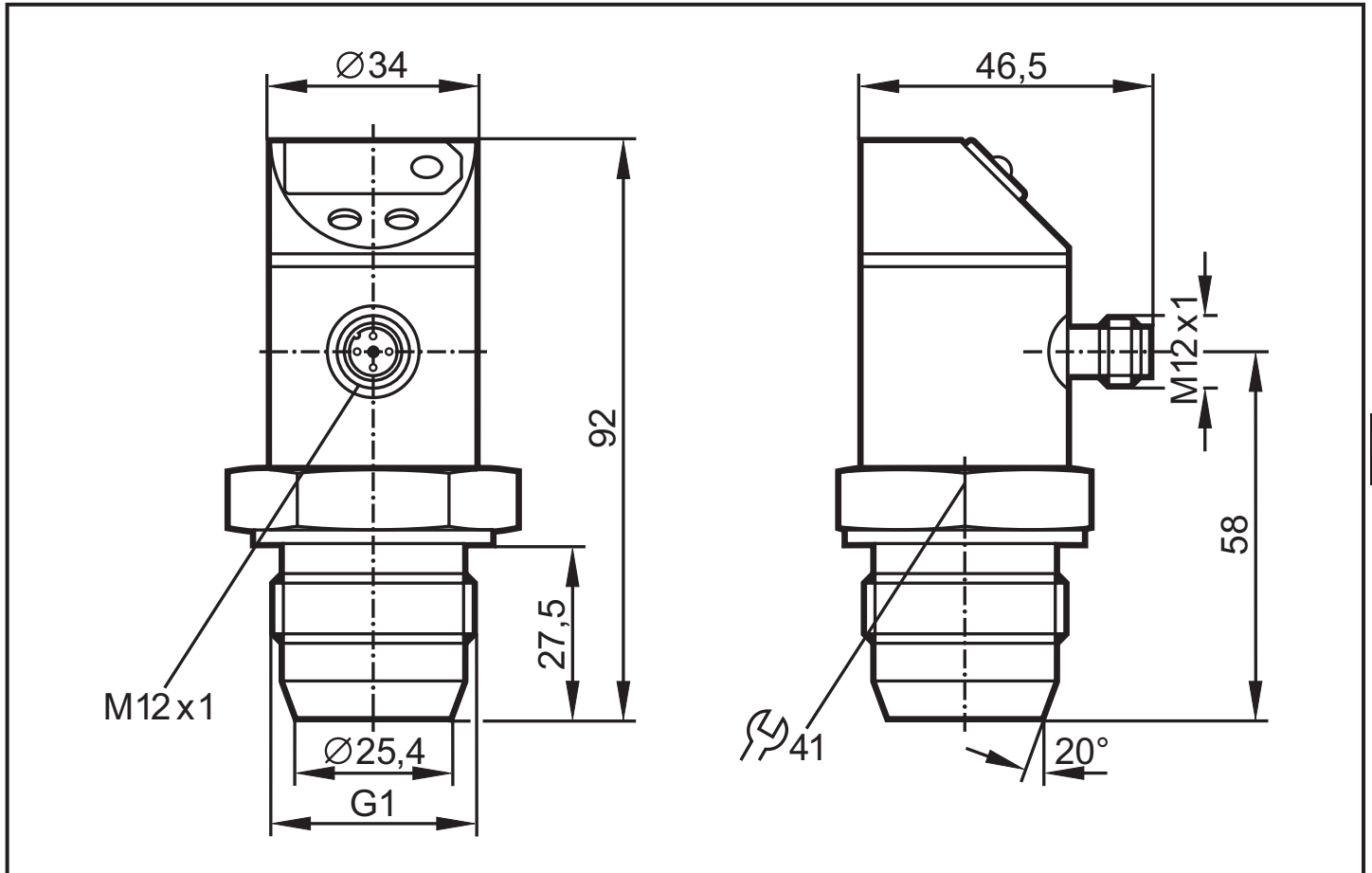

Dimensions are in millimeters

12 Technical data

Operating voltage [V].....	20...30 DC
Current consumption [mA].....	< 60
Current rating [mA]	2 x 250
Short-circuit / reverse polarity / overload protection, integrated watchdog	
Voltage drop [V]	< 2
Power-on delay time [s]	0.2
Min. response time switching outputs [ms]	3
Switching frequency [Hz]	≤ 170
Analogue output	4...20 mA / 0...10 V
Max. load current output [Ω]	$(U_b - 10) \times 50$
Min. load with voltage output [Ω]	2000
Min. response time analog output [ms]	3

UK

Accuracy / deviation (in % of the span)¹⁾

- Characteristics deviation (linearity. incl. hysteresis and repeatability)²⁾ < ± 0.6
- Linearity..... < ± 0.5
- Hysteresis..... < ± 0.1
- Repeatability (with temperature fluctuations < 10 K)..... < ± 0.1
- Long-term stability (in % of the span per year)..... < ± 0.1

Temperature coefficient (TC) in the compensated temperature range 0 ... 80°C (in % of the span per 10 K)

	PF2609, PF2652...PF2657	PF2658
Greatest TC of the zero point	< ± 0.1	< ± 0.1
Greatest TC of the span	< ± 0.2	< ± 0.4

Materials (wetted parts) (PF2609, PF2653...PF2658)

..... stainless steel 316L / 1.4435; surface characteristics: Ra < 0.4 / Rz 4
ceramics (99.9 % Al₂ O₃); PTFE

Materials (wetted parts) (PF2652)

..... stainless steel 316L / 1.4435; surface characteristics: Ra < 0.4 / Rz 4
ceramics; PTFE

Housing materials.....stainless steel 316L / 1.4404; PBT (Pocan);
PC (Makrolon); PEI; EPDM/X (Santoprene); FPM (Viton)

Protection IP 67

Protection classIII

Insulation resistance [MΩ]> 100 (500 V DC)

Shock resistance [g] 50 (DIN / IEC 68-2-27, 11ms)

Vibration resistance [g] 20 (DIN / IEC 68-2-6, 10 - 2000 Hz)

Switching cycles min. 100 million

Operating temperature [°C] -25...80

Medium temperature [°C] -25...80

Storage temperature [°C]..... -40...100

EMC EN 61000-4-2 ESD: 4 / 8 KV

EN 61000-4-3 HF radiated: 10 V/m

EN 61000-4-4 Burst: 2 KV

EN 61000-4-6 HF conducted: 10 V

¹⁾ all indications are referred to a turn down of 1:1

²⁾ limit value setting to DIN 16086

12.1 Setting ranges

		SP1/SP2		rP1/rP2		ASP		AEP		ΔP
		min	max	min	max	min	max	min	max	
PF2609	bar ¹⁾	-0.97	1.00	-0.99	0.98	-0.99	-0.20	-0.50	1.00	0.01
	inHg	-29	30	-30	29	-30	-6	-15	30	1
	kPa	-97	100	-99	98	-99	-20	-50	100	1
PF2652	bar	0.0	100.0	-0.5	99.5	-1.0	75.0	24.0	100.0	0.1
	PSI ²⁾	0	1450	-10	1440	-10	1090	350	1450	10
	MPa ¹⁾	0.00	10.0	-0.05	9.95	-0.10	7.50	2.40	10.0	0.01
PF2653	bar	-0.8	25.0	-0.9	24.9	-1.0	18.8	5.3	25.0	0.1
	PSI	-12	363	-13	362	-15	272	76	363	1
	MPa ¹⁾	-0.08	2.50	-0.09	2.49	-0.10	1.88	0.53	2.50	0.01
PF2654	bar ¹⁾	-0.45	9.99	-0.50	9.94	-0.50	7.49	2.00	9.99	0.01
	PSI	-7	145	-7	144	-7	109	29	145	1
	kPa	-45	999	-50	994	-50	749	200	999	1
PF2656	bar ¹⁾	-0.11	2.50	-0.12	2.49	-0.13	1.88	0.50	2.50	0.01
	PSI	-1.6	36.3	-1.7	36.2	-1.8	27.2	7.3	36.3	0.1
	kPa	-11	250	-12	249	-13	188	50	250	1
PF2657	mbar	-45	999	-50	994	-50	749	200	999	1
	PSI	-0.7	14.5	-0.7	14.4	-0.7	10.9	2.9	14.5	0.1
	kPa	-4.5	99.9	-5.0	99.4	-5.0	74.9	20.0	99.9	0.1
PF2658	mbar	-11	250	-12	249	-13	188	50	250	1
	kPa	-1.1	25.0	-1.2	24.9	-1.3	18.8	5.0	25.0	0.1
	inH ₂ O	-4.4	100	-4.8	99.6	-5.0	74.9	20.1	100	0.1

¹⁾ display in the minus range: -.XX = - 0,XX

²⁾ display: 1/10 of the PSI value

ΔP = increments

More information at www.ifm.com