

DETAIL 1
SCALE 10:1

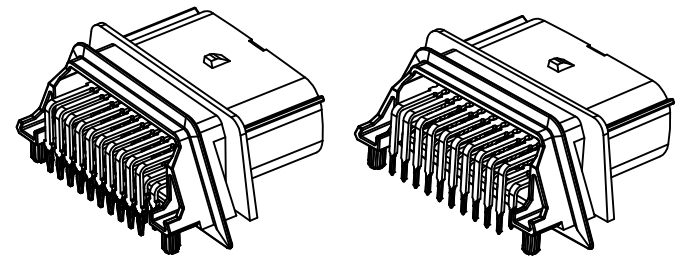

EON SHOWN
(2X10 SHOWN)

SOLDERTAIL SHOWN
(2X10 SHOWN)

NOTES UNLESS OTHERWISE SPECIFIED

1. GENERAL:
 - a. PARTS MUST BE IN COMPLIANCE TO MOLEX CHEMICAL SUBSTANCES FOR PRODUCTS AND PACKAGING SPECIFICATION: ES-40000-5015
 - b. DATA MUST BE SUBMITTED UNDER THE MOLEX PART NUMBER TO IMDS (COMPANY ID#13255)
 - c. 15 PCB PRESS-FIT (COMPLIANT PIN) PER SD-31503-012 REV A
 - d. PCB INTENDED TO BE FR4 0.062" (1.6mm) THICK
2. DESIGN - MATERIALS:
 - a. HOUSING: PBT 30%GF.
 - b. TERMINAL:
 - SOLDER VERSION: COPPER ALLOY.
 - COMPLIANT VERSION: COPPER ALLOY.
3. DESIGN - GEOMETRY:
 - a. THIS IS A 100% CAD GENERATED PART. THE CAD MATHEMATICAL DATA IS THE MASTER FOR THIS PART. FOR DIMENSIONAL OR ANY INFORMATION NOT SHOWN ON THIS DRAWING, ANALYZE THE CAD MODEL.
 - b. PRODUCT DESIGN MODEL NUMBER(S): SEE BOM TABLE
 - c. GEOMETRIC DIMENSIONS AND TOLERANCES PER ASME Y14.5M - 1994
 - d. EDGES AND UNDIMENSIONED DETAILS PER ISO13715
 - e. CORNERS SHOWN AS SHARP TO BE R 0.2 MAX.
 - f. LETTERING SHALL BE 0.15 MAX RAISED. THIS INCLUDES RECYCLING CODE, CAVITY ID, MANUFACTURING LOCATION, AND MOLEX MATERIAL NUMBER.
4. TRUE POSITIONS OF THE EONS AND SOLDERTAIL TO BE VERIFIED WITH A FUNCTIONAL GO/NO GO GAUGE.
5. ALL DIMENSIONS APPLY TO THE PART AS SHIPPED FROM MOLEX. FINAL POSITIONING IS ACHIEVED WITH PCB APPLICATION TOOLING. REFERENCE AS-34829-001.
6. LASER MARKING TO BE MARKED WITH:
 - HUMAN READABLE CODE (HRC)
 - PERMANENTLY APPLIED ON THE PART WITH 15mm LETTER SIZE
 - INFORMATION TO BE PRINTED
 - 9 DIGIT MOLEX MATERIAL NUMBER
 - 5 DIGIT JULIAN MANUFACTURING DATE STAMP DDDYY
7. TRUE POSITION OF THE MATE SIDE CONNECTOR TO BE VERIFIED WITH A GO/NO-GO FUNCTIONAL GAGE
8. ALL DIMENSION WITH OUT BALLOONS ARE NOT MEASURED. SURROGATE DATA FROM THE COMPONENT PRINT WILL BE USED TO MEET DIMENSIONAL REQUIREMENTS.
9. EON (COMPLIANT PIN) DESIGN REQUIRES AN ASSEMBLY FIXTURE FOR INSTALLATION.

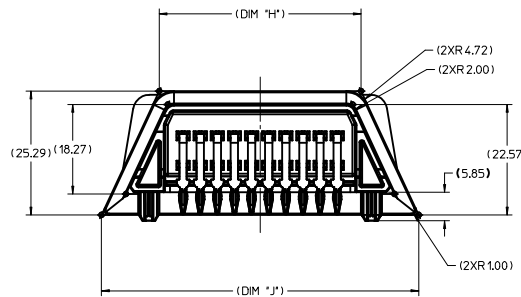
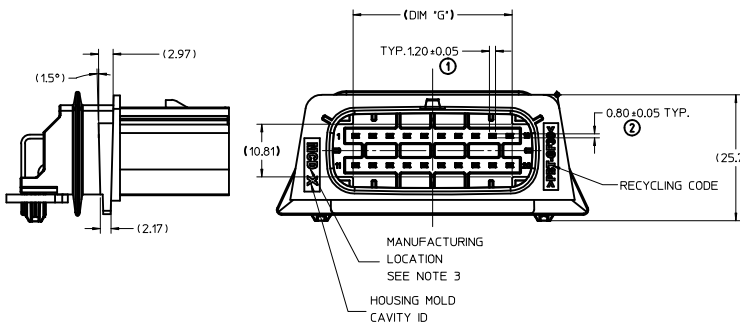

LASER MARKING TO BE SHOWN
IN THIS LOCATION
SEE NOTE 6

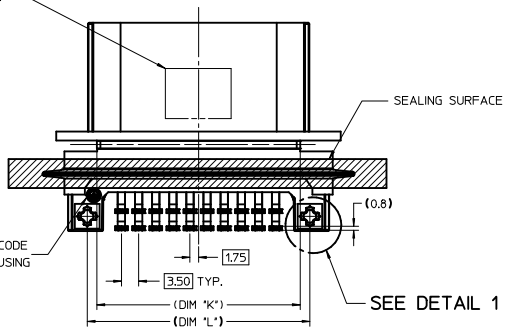

EON DESIGN

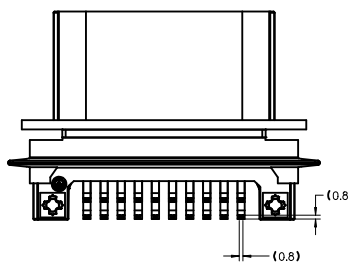

SOLDERTAIL DESIGN

ENTER DESCRIPTION IEC NO: GCA-2012-0084 2 DRAWN: QZHUANG 2012/05/07 CHKD: APPR: PBERG 2012/05/29 REV DESCRIPTION	QUALITY SYMBOLS	GENERAL TOLERANCES (UNLESS SPECIFIED)	DIMENSION STYLE	SCALE	DESIGN UNITS	THIRD ANGLE PROJECTION	
	∇=0 ∇=0 ∇=0	mm INCH 4 PLACES ± --- ± --- 3 PLACES ± --- ± --- 2 PLACES ± 0.13 ± --- 1 PLACE ± 0.25 ± --- ANGULAR ± 3 °	MM ONLY DRAWN BY DATE SONG05 2012/03/22 CHECKED BY DATE TITAN 2012/03/22 APPROVED BY DATE PBERG 2012/05/29	2:1	METRIC	☉ THIRD ANGLE ▽ PROJECTION	
	MATERIAL NO. MOLEX INCORPORATED DOCUMENT NO. SD-34829-001						SHEET NO. 1 OF 3
	DRAFT WHERE APPLICABLE MUST REMAIN WITHIN DIMENSIONS SEE SHEET 2 THIS DRAWING CONTAINS INFORMATION THAT IS PROPRIETARY TO MOLEX INCORPORATED AND SHOULD NOT BE USED WITHOUT WRITTEN PERMISSION						



34829-04XX
34830-04XX

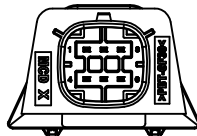

34829-06XX
34830-06XX

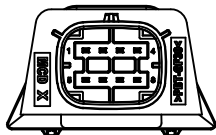

34829-08XX
34830-08XX

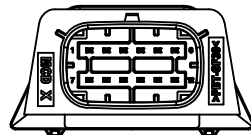

34829-12XX
34830-12XX

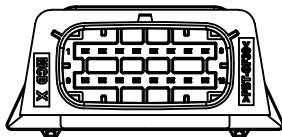

34829-16XX
34830-16XX

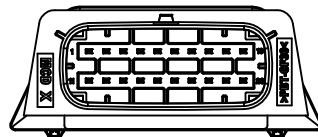

34829-20XX
34830-20XX

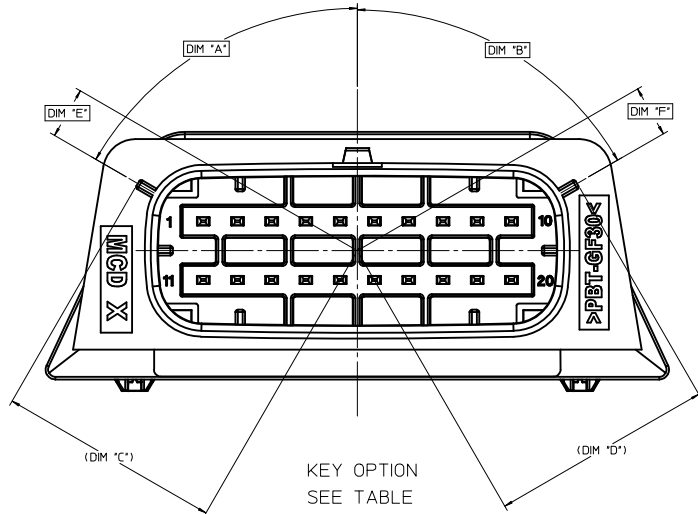

MATERIAL NUMBER		DESCRIPTION	KEY CODING	COLOR	DIMENSIONS										STATUS	
EON	SOLDERTAIL				A	B	C	D	E	F	G	H	J	K		L
348290401	348300401	2x2 WAY HEADER	A	BLACK	60°	60°	10.75	10.75	1.73	1.73	4.53	13.24	36.83	13.54	17.50	
348290402	348300402		B	LT GRAY	40°	60°	11.16	10.75	0.57	1.73						
348290403	348300403		C	DK GRAY	60°	40°	10.75	11.16	1.73	0.57						
348290404	348300404		D	BLACK	40°	40°	11.16	11.16	0.57	0.57						
348290601	348300601	2x3 WAY HEADER	A	BLACK	60°	60°	12.27	12.27	0.86	0.86	8.03	16.74	40.33	17.04	21.00	
348290602	348300602		B	LT GRAY	25°	60°	11.93	12.27	1.94	0.86						
348290603	348300603		C	DK GRAY	60°	25°	12.27	11.93	0.86	1.94						
348290604	348300604		D	BLACK	25°	25°	11.93	11.93	1.94	1.94						
348290801	348300801	2x4 WAY HEADER	A	BLACK	60°	60°	13.78	13.78	0.02	0.02	11.53	20.24	43.83	20.54	24.50	TOOLED
348290802	348300802		B	LT GRAY	25°	60°	12.67	13.78	3.53	0.02						
348290803	348300803		C	DK GRAY	60°	25°	13.78	12.67	0.02	3.53						
348290804	348300804		D	BLACK	25°	25°	12.67	12.67	3.53	3.53						
348291201	348301201	2x6 WAY HEADER	A	BLACK	60°	60°	16.81	16.81	1.77	1.77	18.53	27.24	50.83	27.54	31.50	
348291202	348301202		B	LT GRAY	25°	60°	14.14	16.81	6.70	1.77						
348291203	348301203		C	DK GRAY	60°	25°	16.81	14.14	1.77	6.70						
348291204	348301204		D	BLACK	25°	25°	14.14	14.14	6.70	6.70						
348291601	348301601	2x8 WAY HEADER	A	BLACK	60°	60°	19.85	19.85	3.52	3.52	25.53	34.24	57.83	34.54	38.50	
348291602	348301602		B	LT GRAY	25°	60°	15.62	19.85	9.87	3.52						
348291603	348301603		C	DK GRAY	60°	25°	19.85	15.62	3.52	9.87						
348291604	348301604		D	BLACK	25°	25°	15.62	15.62	9.87	9.87						
348292001	348302001	2x10 WAY HEADER	A	BLACK	60°	60°	22.88	22.88	5.27	5.27	32.53	41.24	64.83	41.54	45.50	TOOLED
348292002	348302002		B	LT GRAY	25°	60°	17.10	22.88	13.05	5.27						
348292003	348302003		C	DK GRAY	60°	25°	22.88	17.10	5.27	13.05						
348292004	348302004		D	BLACK	25°	25°	17.10	17.10	13.05	13.05						

ENTER DESCRIPTION IEC NO: GCA/2012-0084 DRAWN: GDZHANG 2012/05/07 CHKO: APPR: PBERG 2012/05/29 REV DESCRIPTION	QUALITY SYMBOLS ∇=0 ∇=0 ∇=0	GENERAL TOLERANCES (UNLESS SPECIFIED) mm INCH 4 PLACES ± --- ± --- 3 PLACES ± --- ± --- 2 PLACES ± 0.13 ± --- 1 PLACE ± 0.25 ± --- ANGULAR ± 3°	DIMENSION STYLE MM ONLY DRAWN BY DATE LSONG05 2012/03/22 CHECKED BY DATE TITAN 2012/03/22 APPROVED BY DATE PBERG 2012/05/29	SCALE 2:1 DESIGN UNITS METRIC THIRD ANGLE PROJECTION	TITLE MX150 DUAL ROW R/A HEADER ASSEMBLY
	MATERIAL NO. SD-34829-001 DOCUMENT NO.	MOLEX INCORPORATED	SHEET NO. 2 OF 3	THIS DRAWING CONTAINS INFORMATION THAT IS PROPRIETARY TO MOLEX INCORPORATED AND SHOULD NOT BE USED WITHOUT WRITTEN PERMISSION	

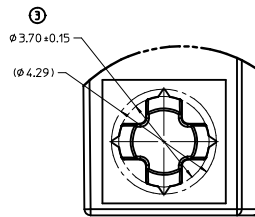
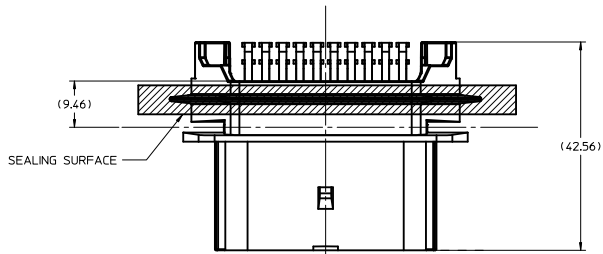

DETAIL 1
SCALE 10:1

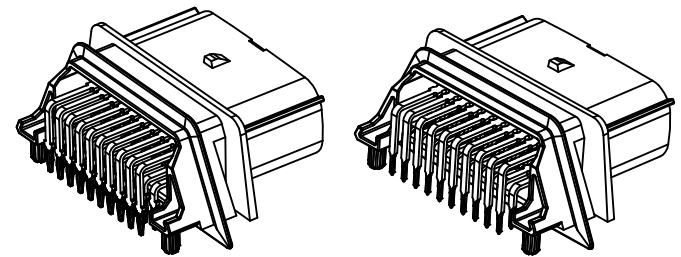

NOTES UNLESS OTHERWISE SPECIFIED

1. GENERAL:
 - a. PARTS MUST BE IN COMPLIANCE TO MOLEX CHEMICAL SUBSTANCES FOR PRODUCTS AND PACKAGING SPECIFICATION: ES-40000-5015
 - b. DATA MUST BE SUBMITTED UNDER THE MOLEX PART NUMBER TO IMDS (COMPANY ID#13255)
 - c. 15 PCB PRESS-FIT (COMPLIANT PIN) PER SD-31503-012 REV A
 - d. PCB INTENDED TO BE FR4 0.062" (1.6mm) THICK
2. DESIGN - MATERIALS:
 - a. HOUSING: PBT 30%GF.
 - b. TERMINAL:
 - SOLDER VERSION: COPPER ALLOY.
 - COMPLIANT VERSION: COPPER ALLOY.
3. DESIGN - GEOMETRY:
 - a. THIS IS A 100% CAD GENERATED PART. THE CAD MATHEMATICAL DATA IS THE MASTER FOR THIS PART. FOR DIMENSIONAL OR ANY INFORMATION NOT SHOWN ON THIS DRAWING, ANALYZE THE CAD MODEL.
 - b. PRODUCT DESIGN MODEL NUMBER(S): SEE BOM TABLE
 - c. GEOMETRIC DIMENSIONS AND TOLERANCES PER ASME Y14.5M - 1994
 - d. EDGES AND UNDIMENSIONED DETAILS PER ISO13715
 - e. CORNERS SHOWN AS SHARP TO BE R 0.2 MAX.
 - f. LETTERING SHALL BE 0.15 MAX RAISED. THIS INCLUDES RECYCLING CODE, CAVITY ID, MANUFACTURING LOCATION, AND MOLEX MATERIAL NUMBER.
4. TRUE POSITIONS OF THE EONS AND SOLDERTAIL TO BE VERIFIED WITH A FUNCTIONAL GO/NO GO GAUGE.
5. ALL DIMENSIONS APPLY TO THE PART AS SHIPPED FROM MOLEX. FINAL POSITIONING IS ACHIEVED WITH PCB APPLICATION TOOLING. REFERENCE AS-34829-001.
6. LASER MARKING TO BE MARKED WITH:
 - HUMAN READABLE CODE (HRC)
 - PERMANENTLY APPLIED ON THE PART WITH 15mm LETTER SIZE
 - INFORMATION TO BE PRINTED
 - 9 DIGIT MOLEX MATERIAL NUMBER
 - 5 DIGIT JULIAN MANUFACTURING DATE STAMP DDDYY
7. TRUE POSITION OF THE MATE SIDE CONNECTOR TO BE VERIFIED WITH A GO/NO-GO FUNCTIONAL GAGE
8. ALL DIMENSION WITH OUT BALLOONS ARE NOT MEASURED. SURROGATE DATA FROM THE COMPONENT PRINT WILL BE USED TO MEET DIMENSIONAL REQUIREMENTS.
9. EON (COMPLIANT PIN) DESIGN REQUIRES AN ASSEMBLY FIXTURE FOR INSTALLATION.

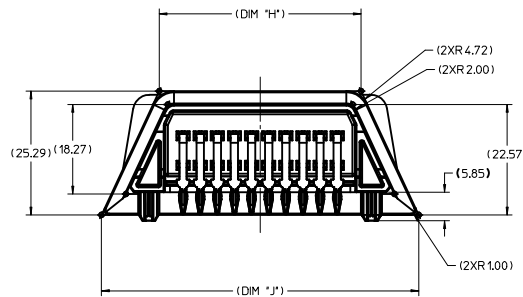
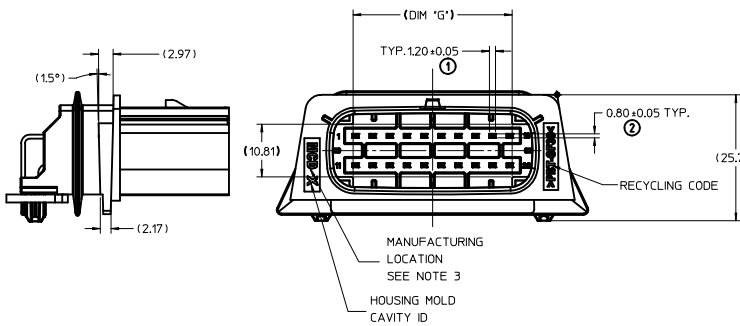

LASER MARKING TO BE SHOWN
IN THIS LOCATION
SEE NOTE 6

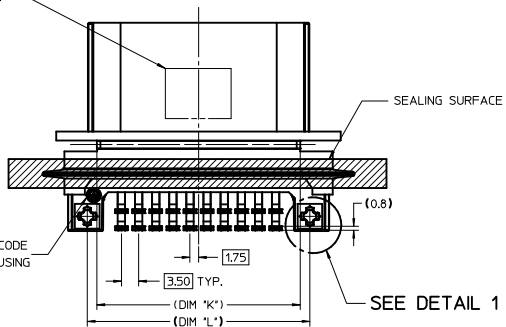

EON DESIGN

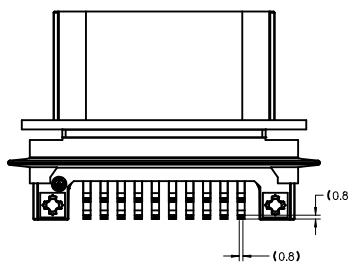

SOLDERTAIL DESIGN

ENTER DESCRIPTION IEC NO.: GCA-2012-0084 DRAWN: QZHUANG CHYK: APPR: PBERG 2012/05/07 2012/05/29 DESCRIPTION	QUALITY SYMBOLS	GENERAL TOLERANCES (UNLESS SPECIFIED)	DIMENSION STYLE	SCALE	DESIGN UNITS	THIRD ANGLE PROJECTION	
	∇=0 ∇=0 ∇=0	mm INCH	4 PLACES ± --- ± --- 3 PLACES ± --- ± --- 2 PLACES ± 0.13 ± --- 1 PLACE ± 0.25 ± --- ANGULAR ± 3 °	MM ONLY DRAWN BY DATE SONG05 2012/03/22 CHECKED BY DATE TITAN 2012/03/22 APPROVED BY DATE PBERG 2012/05/29	2:1	METRIC	THIRD ANGLE PROJECTION
	DRAFT WHERE APPLICABLE MUST REMAIN WITHIN DIMENSIONS	MATERIAL NO. SEE SHEET 2 SIZE D	DOCUMENT NO. SD-34829-001	MOLEX INCORPORATED	SHEET NO. 1 OF 3		
	THIS DRAWING CONTAINS INFORMATION THAT IS PROPRIETARY TO MOLEX INCORPORATED AND SHOULD NOT BE USED WITHOUT WRITTEN PERMISSION						



34829-04XX
34830-04XX

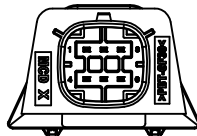

34829-06XX
34830-06XX

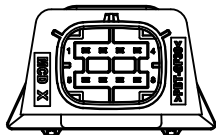

34829-08XX
34830-08XX

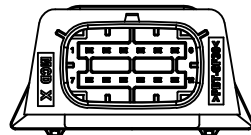

34829-12XX
34830-12XX

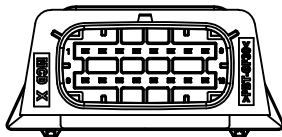

34829-16XX
34830-16XX

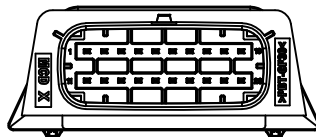

34829-20XX
34830-20XX

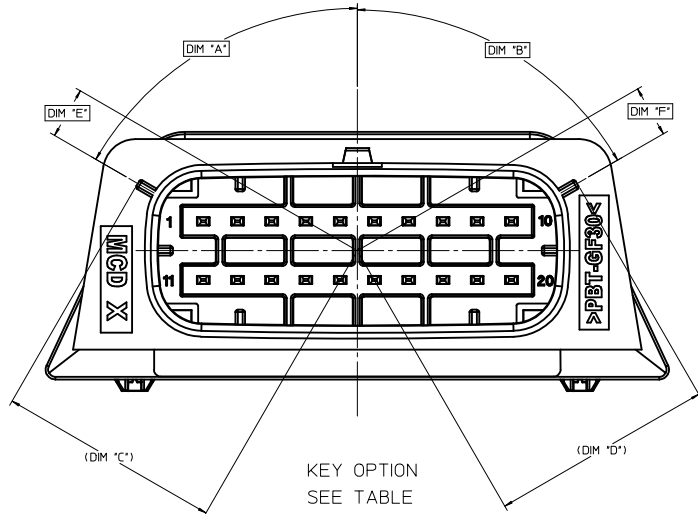

MATERIAL NUMBER		DESCRIPTION	KEY CODING	COLOR	DIMENSIONS										STATUS	
EON	SOLDERTAIL				A	B	C	D	E	F	G	H	J	K		L
348290401	348300401	2x2 WAY HEADER	A	BLACK	60°	60°	10.75	10.75	1.73	1.73	4.53	13.24	36.83	13.54	17.50	
348290402	348300402		B	LT GRAY	40°	60°	11.16	10.75	0.57	1.73						
348290403	348300403		C	DK GRAY	60°	40°	10.75	11.16	1.73	0.57						
348290404	348300404		D	BLACK	40°	40°	11.16	11.16	0.57	0.57						
348290601	348300601	2x3 WAY HEADER	A	BLACK	60°	60°	12.27	12.27	0.86	0.86	8.03	16.74	40.33	17.04	21.00	
348290602	348300602		B	LT GRAY	25°	60°	11.93	12.27	1.94	0.86						
348290603	348300603		C	DK GRAY	60°	25°	12.27	11.93	0.86	1.94						
348290604	348300604		D	BLACK	25°	25°	11.93	11.93	1.94	1.94						
348290801	348300801	2x4 WAY HEADER	A	BLACK	60°	60°	13.78	13.78	0.02	0.02	11.53	20.24	43.83	20.54	24.50	TOOLED
348290802	348300802		B	LT GRAY	25°	60°	12.67	13.78	3.53	0.02						
348290803	348300803		C	DK GRAY	60°	25°	13.78	12.67	0.02	3.53						
348290804	348300804		D	BLACK	25°	25°	12.67	12.67	3.53	3.53						
348291201	348301201	2x6 WAY HEADER	A	BLACK	60°	60°	16.81	16.81	1.77	1.77	18.53	27.24	50.83	27.54	31.50	
348291202	348301202		B	LT GRAY	25°	60°	14.14	16.81	6.70	1.77						
348291203	348301203		C	DK GRAY	60°	25°	16.81	14.14	1.77	6.70						
348291204	348301204		D	BLACK	25°	25°	14.14	14.14	6.70	6.70						
348291601	348301601	2x8 WAY HEADER	A	BLACK	60°	60°	19.85	19.85	3.52	3.52	25.53	34.24	57.83	34.54	38.50	
348291602	348301602		B	LT GRAY	25°	60°	15.62	19.85	9.87	3.52						
348291603	348301603		C	DK GRAY	60°	25°	19.85	15.62	3.52	9.87						
348291604	348301604		D	BLACK	25°	25°	15.62	15.62	9.87	9.87						
348292001	348302001	2x10 WAY HEADER	A	BLACK	60°	60°	22.88	22.88	5.27	5.27	32.53	41.24	64.83	41.54	45.50	TOOLED
348292002	348302002		B	LT GRAY	25°	60°	17.10	22.88	13.05	5.27						
348292003	348302003		C	DK GRAY	60°	25°	22.88	17.10	5.27	13.05						
348292004	348302004		D	BLACK	25°	25°	17.10	17.10	13.05	13.05						

ENTER DESCRIPTION EIC NO: GCA2012-0084 DRAWN: GDZHANG 2012/05/07 CHKO: APPR: PBERG 2012/05/29	QUALITY SYMBOLS ∇=0 ∇=0 ∇=0	GENERAL TOLERANCES (UNLESS SPECIFIED) 4 PLACES ± --- INCH 3 PLACES ± --- INCH 2 PLACES ± 0.13 INCH 1 PLACE ± 0.25 INCH ANGULAR ± 3°	DIMENSION STYLE MM ONLY	SCALE 2:1 DESIGN UNITS METRIC THIRD ANGLE PROJECTION	DRAWN BY LSONG05 DATE 2012/03/22	TITLE MX150 DUAL ROW R/A HEADER ASSEMBLY
					CHECKED BY TITAN DATE 2012/03/22	
DRAFT WHERE APPLICABLE MUST REMAIN WITHIN DIMENSIONS			MATERIAL NO. SEE TABLE	DOCUMENT NO. SD-34829-001	SHEET NO. 2 OF 3	MOLEX INCORPORATED
THIS DRAWING CONTAINS INFORMATION THAT IS PROPRIETARY TO MOLEX INCORPORATED AND SHOULD NOT BE USED WITHOUT WRITTEN PERMISSION						

